

Test Bank for College Algebra 10th Edition by Sullivan

ISBN 0321979478 9780321979476

Full link download

Test Bank:

<https://testbankpack.com/p/test-bank-for-college-algebra-10th-edition-by-sullivan-isbn-0321979478-9780321979476/>

Ch. 2

Graphs

2.1 The Distance and Midpoint Formulas

1 Rectangular

Coordinates

MULTIPLE CHOICE. Choose the one alternative that best completes the statement or answers the question.

Name the quadrant in which the point is located. 1)

(11, 4)

A) I

B) II

C) III

D) IV

2) (-15, 17)

A) I

B) II

C) III

D) IV

3) (-5, -5)

A) I

B) II

C) III

D) IV

4) (14, -7)

A) I

B) II

C) III

D) IV

Identify the points in the graph for the ordered pairs.

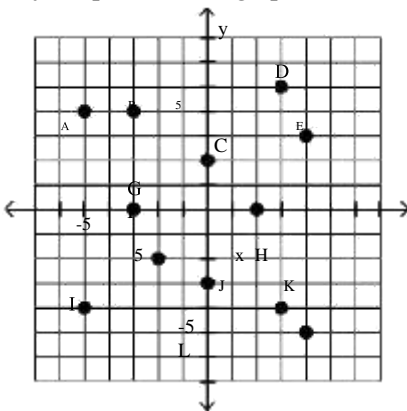

5) (0, 2), (4, 3)

A) C and E

B) F and E

C) B and C

D) C and K

6) (-5, -4), (0, -3)

A) I and J

B) A and G

C) G and I

D) A and J

7) (-3, 4), (2, 0), (4, -5)

A) B, F, and L

B) B, C, and L

C) F, K, and L

D) A, B, and F

8) (3, 5), (-3, 0)

A) D and G

D) L and J

B) D and J

C) I and G



Give the coordinates of the points shown on the graph.

9)

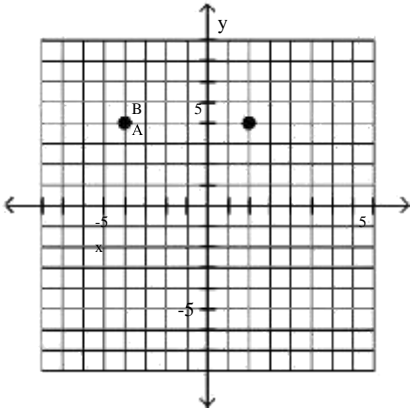

- A) $A = (2, 4), B = (-4, 4)$
 B) $A = (4, 20), B = (4, -4)$ C) $A = (2, 4), B = (4, 4)$
 D) $A = (2, 4), B = (4, -4)$

B)

10)

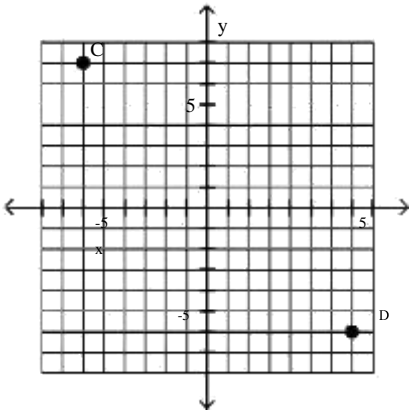

- A) $C = (-6, 7), D = (7, -6)$
 B) $C = (7, -6), D = (-6, 7)$ C) $C = (-6, -6), D = (7, -6)$
 D) $C = (-6, 7), D = (-6, 7)$

B) C

11)

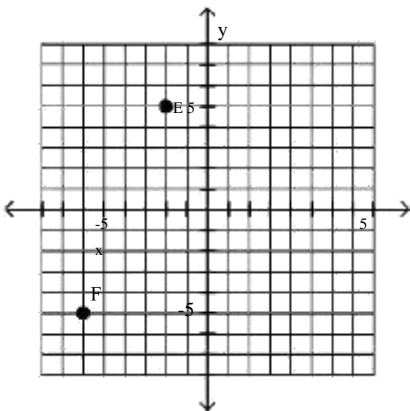

- A) $E = (-2, 5), F = (-6, -5)$
 B) $E = (5, -2), F = (-5, -6)$ C) $E = (-2, -5), F = (5, -5)$
 D) $E = (-6, -5), F = (-2, 5)$

B) E



12)

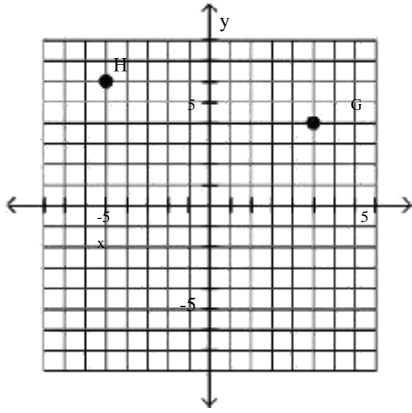

- A) $G = (5, 4)$, $H = (-5, 6)$
B) $G = (4, 5)$, $H = (6, -5)$ C) $G = (5, 6)$, $H = (4, 6)$
D) $G = (5, 4)$, $H = (6, -5)$

B)

Plot the point in the xy -plane. Tell in which quadrant or on what axis the point lies. 13)

(1, 6)

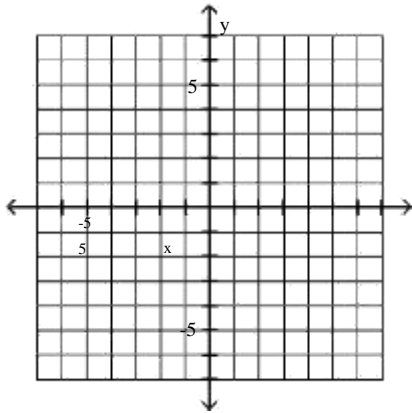

- A)
B)

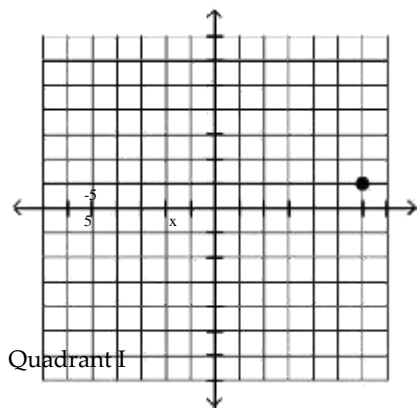
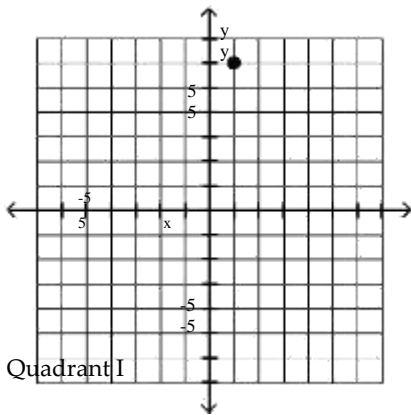

C)
D)

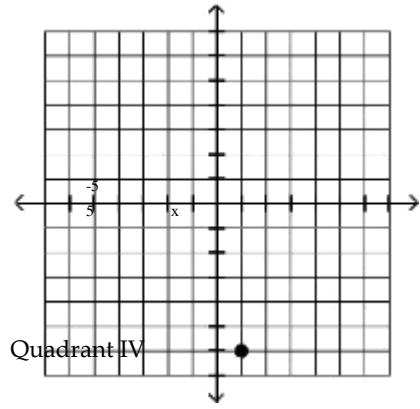
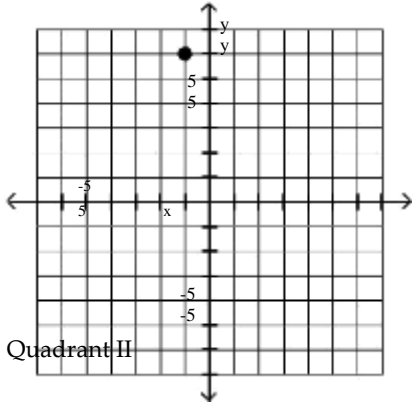

14) (-1, 3)

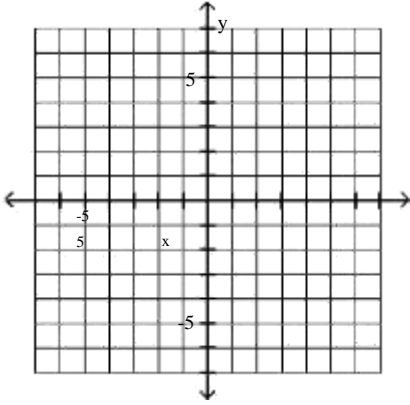

A)
B)

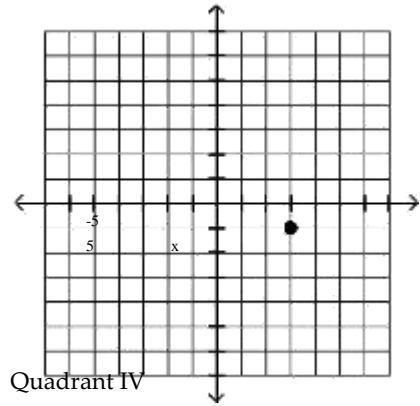
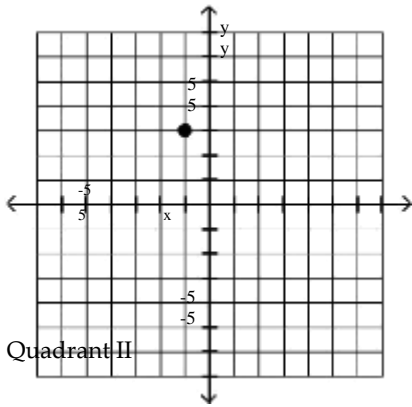

C)
D)

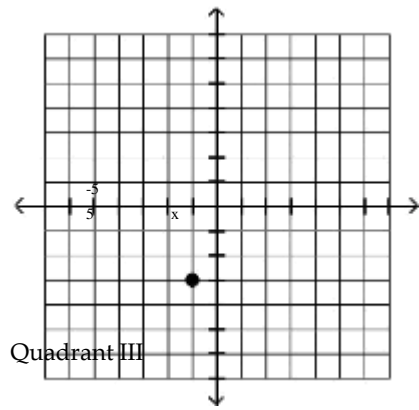
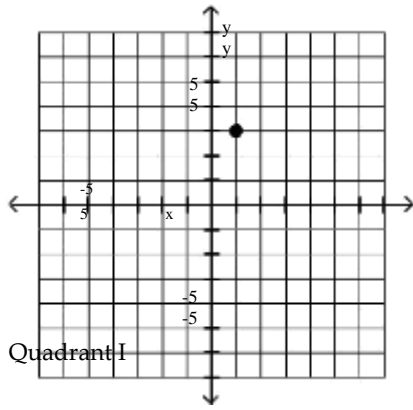

15) (1, -2)

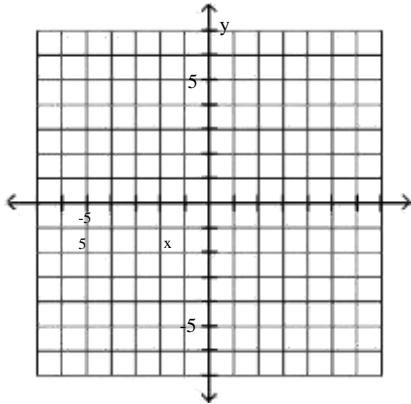

A)
B)

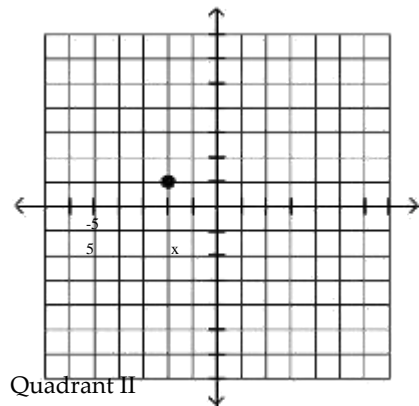
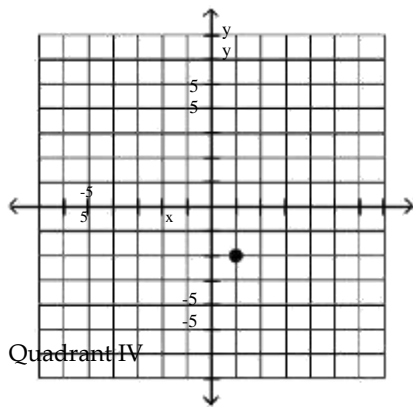

C)
D)

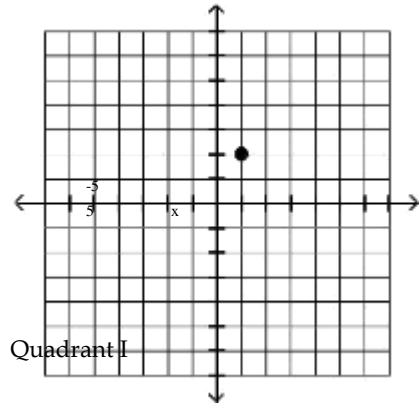
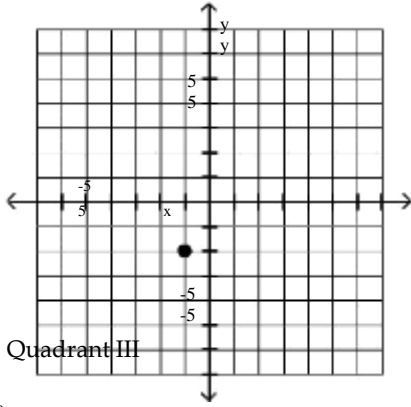

16) (-6, -4)

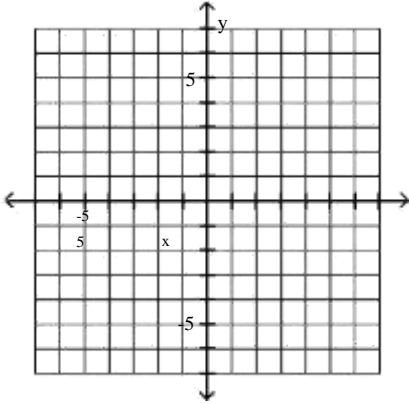

A)
B)

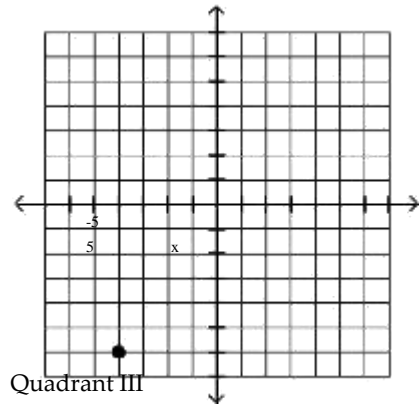
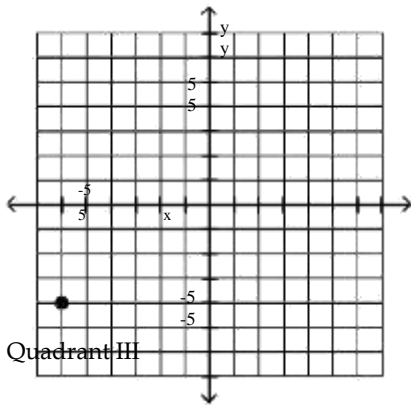

C)
D)

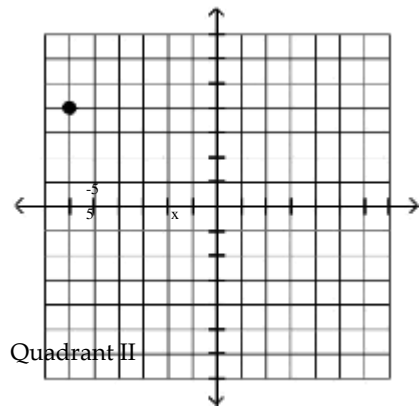
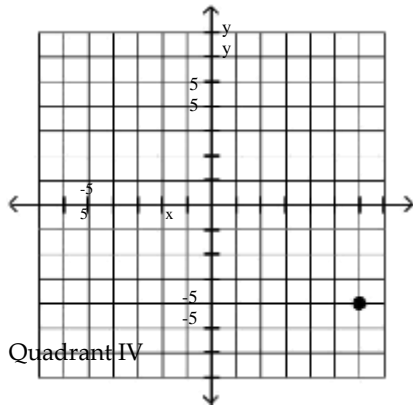

17) (0, -6)

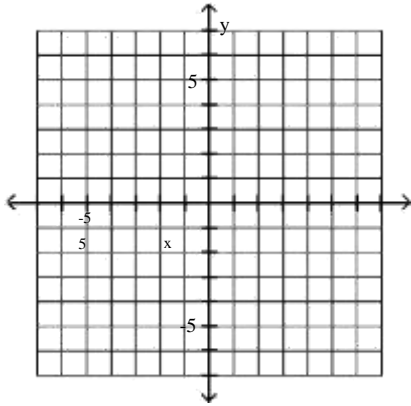

A)
B)

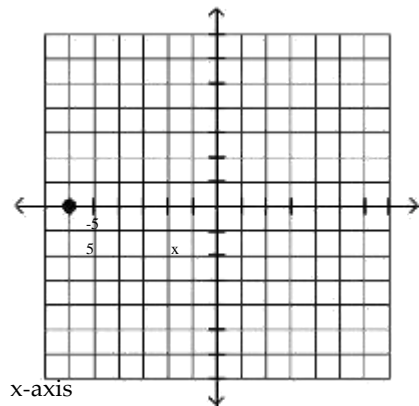
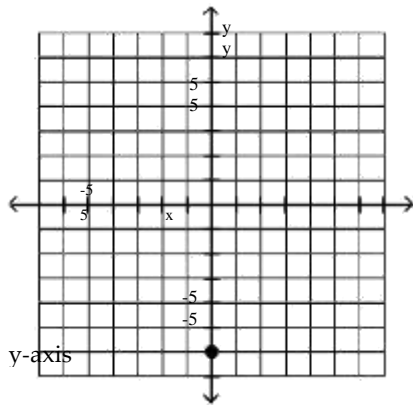

C)
D)

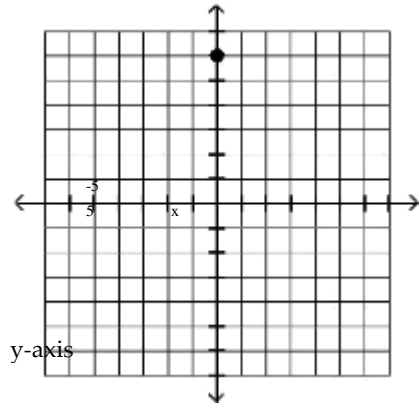
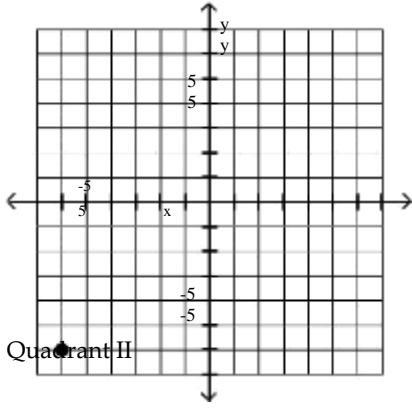

18) (2, 0)

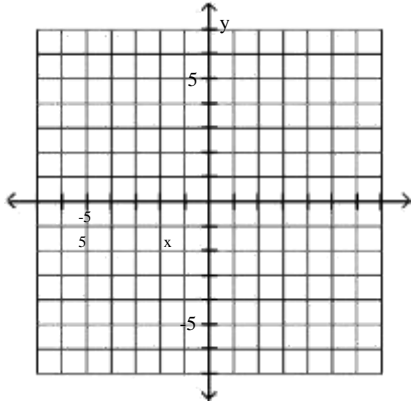

A)
B)

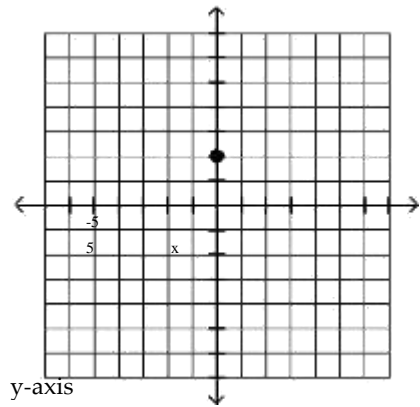
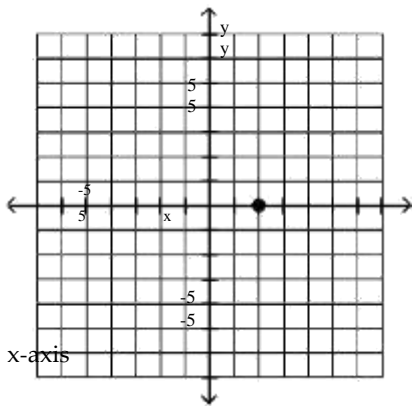

- C)
D)

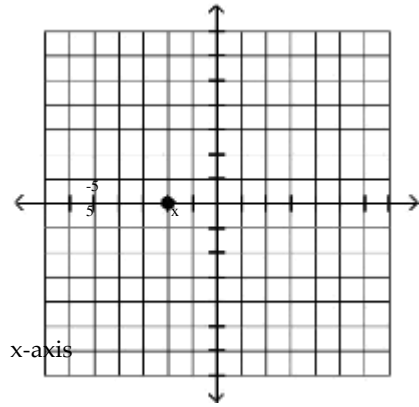
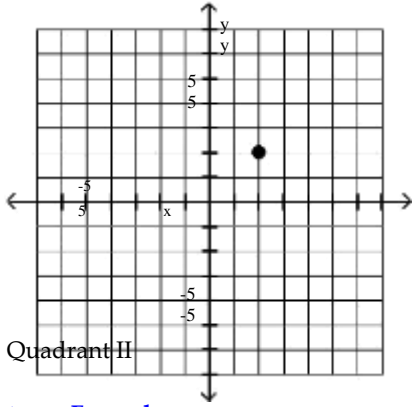

2 Use the Distance Formula

MULTIPLE CHOICE. Choose the one alternative that best completes the statement or answers the question.

Find the distance $d(P_1, P_2)$ between the points P_1 and P_2 .

1)

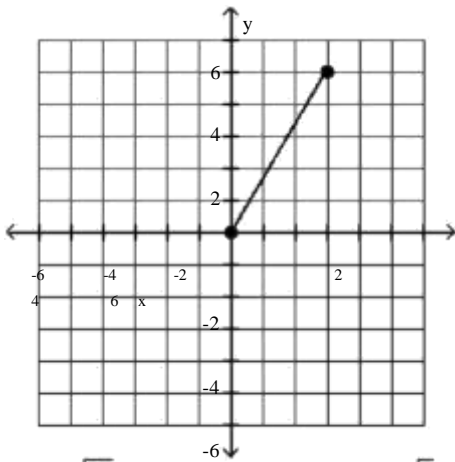

- A) $\sqrt{34}$
C) 3

- B) $\sqrt{2}$
D) 1

2)

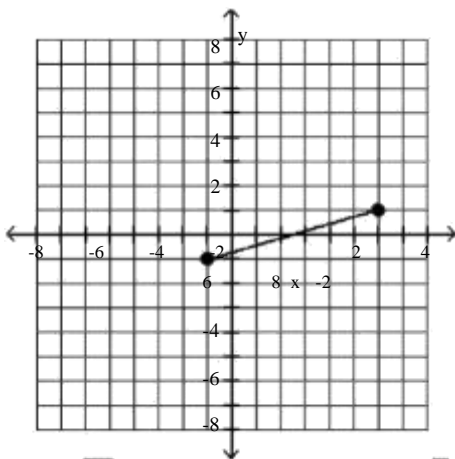

- A) $\sqrt{53}$
C) 14

- B) $3\sqrt{5}$
D) 5



3)

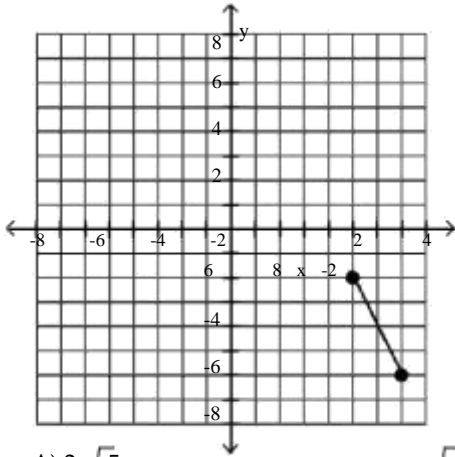

- A) $2\sqrt{5}$
C) 12

- $\sqrt{\quad}$ B) 12 3
D) 6

4)

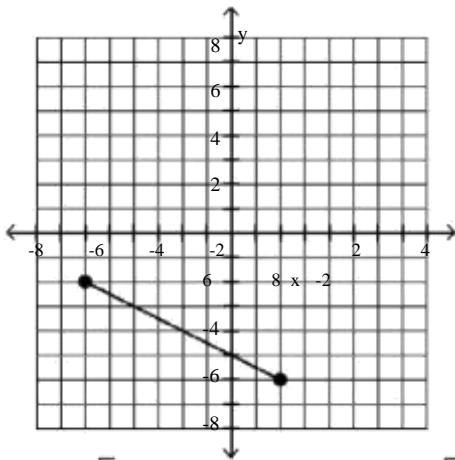

- A) $4\sqrt{5}$
48

- $\sqrt{\quad}$ B) 48 3
D) 12

C)

5) $P_1 = (4, 4); P_2 = (4, -5)$

- A) 9

- B) 3

- C) 10

- D) 8

6) $P_1 = (1, -4); P_2 = (-5, -12)$

- A) 10

- B) 100

- C) 11

- D) 20

7) $P_1 = (0, 10); P_2 = (-8, 10)$

- A) 8

- B) 10

- C) $2\sqrt{41}$

- D) 64

8) $P_1 = (0, 0); P_2 = (-1, -8)$

- A) $\sqrt{65}$
D) $2i \quad 2$

- B) 65

- C) 9

$\sqrt{\quad}$

9) $P_1 = (1, 6); P_2 = (-7, -1)$

- A) $\sqrt{113}$
C) 56

$\sqrt{\quad}$

- B) 15

- D) 1

10) $P_1 = (3, -1); P_2 = (7, -3)$

- A) $2\sqrt{5}$
C) 12

$\sqrt{\quad}$

- B) 12 3

- D) 6

11) $P_1 = (-3, -4)$; $P_2 = (6, 2)$

A) $3\sqrt{13}$
45

$\sqrt{\quad}$ B) 45 5
D) 3

C)

12) $P_1 = (-0.1, -0.9)$; $P_2 = (1.5, -1.8)$ Round to three decimal places, if necessary.

A) 1.836
D) 1.936

B) 12.5

C) 5.805

Decide whether or not the points are the vertices of a right triangle. 13)

(3, -2), (8, -2), (8, 2)

- A) Yes
B) No

14) (3, -4), (5, 0), (7, -1)

- A) Yes
B) No

15) (-8, 5), (-2, 7), (-3, 2)

- A) Yes
B) No

16) (-10, -1), (-4, 1), (2, -6)

- A) Yes

B) No

Solve the problem.

17) Find all values of k so that the given points are $\sqrt{29}$ units apart.

(-5, 5), (k, 0)

- A) -3, -7
B) -7

C) 3, 7

D) 7

18) Find the area of the right triangle ABC with $A = (-2, 7)$, $B = (7, -1)$, $C = (3, 9)$.

A) 29 square units

B) 58 square units

$\frac{58}{2}$ square units
 $\sqrt{\frac{2}{2}}$ D)

$\sqrt{29}$ square units

C)

19) Find all the points having an x-coordinate of 9 whose distance from the point (3, -2) is 10.

A) (9, 6), (9, -10)
D) (9, 13), (9, -7)

B) (9, 2), (9, -4)

C) (9, -12), (9, 8)

20) A middle school's baseball playing field is a square, 60 feet on a side. How far is it directly from home plate to second base (the diagonal of the square)? If necessary, round to the nearest foot.

A) 85 feet
D) 92 feet

B) 86 feet

C) 84 feet

21) A motorcycle and a car leave an intersection at the same time. The motorcycle heads north at an average speed of 20 miles per hour, while the car heads east at an average speed of 48 miles per hour. Find an expression for their distance apart in miles at the end of t hours.

A) $52t$ miles
D) $2t + 13$ miles

$\sqrt{\quad}$ B) $t + 68$ miles

$\sqrt{\quad}$

C) $52 + t$ miles $\sqrt{\quad}$

22) A rectangular city park has a jogging loop that goes along a length, width, and diagonal of the park. To the nearest yard, find the length of the jogging loop, if the length of the park is 125 yards and its width is 75 yards.

A) 346 yards
D) 145 yards

B) 146 yards

C) 345 yards

23) Find the length of each side of the triangle determined by the three points P_1 , P_2 , and P_3 . State whether

the triangle is an isosceles triangle, a right triangle, neither of these, or both.

$P_1 = (-5, -4), P_2 = (-3, 4), P_3 = (0, -1)$

A) $d(P_1, P_2) = 17\sqrt{2}$, $d(P_2, P_3) = 3\sqrt{17}$, $d(P_1, P_3) = \sqrt{34}$
both

B) $d(P_1, P_2) = 17\sqrt{2}$, $d(P_2, P_3) = 3\sqrt{17}$, $d(P_1, P_3) = \sqrt{34}$
isosceles triangle

C) $d(P_1, P_2) = 17\sqrt{2}$, $d(P_2, P_3) = 3\sqrt{17}$, $d(P_1, P_3) = 5\sqrt{2}$
right triangle

D) $d(P_1, P_2) = 17\sqrt{2}$, $d(P_2, P_3) = 3\sqrt{17}$, $d(P_1, P_3) = 5\sqrt{2}$
neither

3 Use the Midpoint Formula

MULTIPLE CHOICE. Choose the one alternative that best completes the statement or answers the question.

Find the midpoint of the line segment joining the points P_1 and P_2 .

- 1) $P_1 = (2, 1); P_2 = (8, 5)$
A) (5, 3) B) (10, 6) C) (-6, -4) D) (3, 5)

- 2) $P_1 = (1, 8); P_2 = (-9, 2)$
A) (-4, 5) B) (5, 3) C) (10, 6) D) (-8, 10)

- 3) $P_1 = (7, 1); P_2 = (-16, -16)$
A) $\left(-\frac{9}{2}, \frac{15}{2} \right)$ B) $\left(\frac{23}{2}, -\frac{17}{2} \right)$ C) $(-9, -15)$ D) (9, 15)

- 4) $P_1 = (-0.6, 0.9); P_2 = (2.6, -2.2)$
A) (1, -0.65) B) (-0.65, 1) C) (1.6, -1.55) D) (-1.55, 1.6)

- 5) $P_1 = (b, 9); P_2 = (0, 3)$
A) $\left(\frac{b}{2}, 6 \right)$ B) $(b, 12)$ C) $\left(\frac{b}{2}, 6 \right)$ D) $(b, 6)$

- 6) $P_1 = (3a, 5); P_2 = (4a, 6)$
A) $\left(\frac{7a}{2}, \frac{11}{2} \right)$ B) $(7a, 11)$ C) $(a, 1)$ D) $\left(\frac{11a}{2}, \frac{7a}{2} \right)$

Solve the problem.

- 7) If (-2, -4) is the endpoint of a line segment, and (1, -2) is its midpoint, find the other endpoint.
A) (4, 0) B) (4, -6) C) (-8, -8)
D) (2, 2)

- 8) If (-4, 2) is the endpoint of a line segment, and (-9, -1) is its midpoint, find the other endpoint. A)
(-14, -4) B) (-14, 5) C) (6, 8)
D) (-10, -8)

- 9) If (-2, 5) is the endpoint of a line segment, and (2, 3) is its midpoint, find the other endpoint. A)
(6, 1) B) (6, 7) C) (-10, 9)
D) (-6, 13)

- 10) If (8, 9) is the endpoint of a line segment, and (4, 12) is its midpoint, find the other endpoint. A)

(0, 15)
D) (14, 1)

B) (0, 6)

C) (16, 3)



11) The medians of a triangle intersect at a point. The distance from the vertex to the point is exactly two-thirds of the distance from the vertex to the midpoint of the opposite side. Find the exact distance of that point from the vertex A(3, 4) of a triangle, given that the other two vertices are at (0, 0) and (8, 0).

A) $\frac{2\sqrt{173}}{3}$

B) $\frac{\sqrt{17}}{3}$

C) 2

D) 3

8

3

2.2 Graphs of Equations in Two Variables; Intercepts; Symmetry

1 Graph Equations by Plotting Points

MULTIPLE CHOICE. Choose the one alternative that best completes the statement or answers the question.

Determine whether the given point is on the graph of the equation. 1)

Equation: $y = x^3 - x\sqrt{}$

Point: (-4, -66)

A) No

B) Yes

2) Equation: $x^2 + y^2 = 4$

Point: (2, 0)

A) Yes

B) No



Graph the equation by plotting points.

3) $y = x - 2$

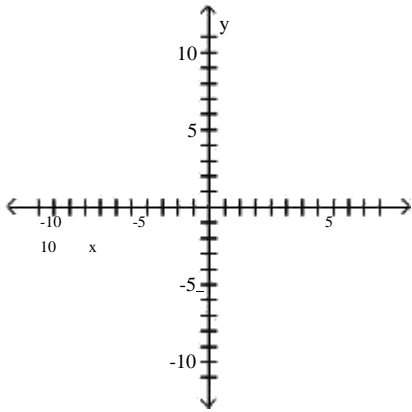

A)

B)

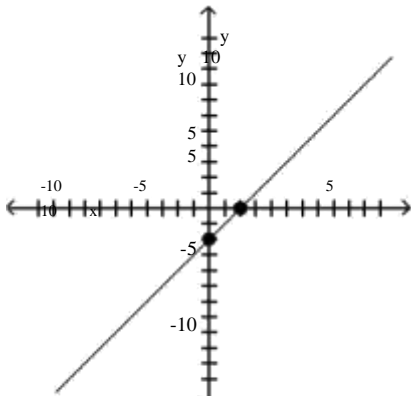

C)

D)

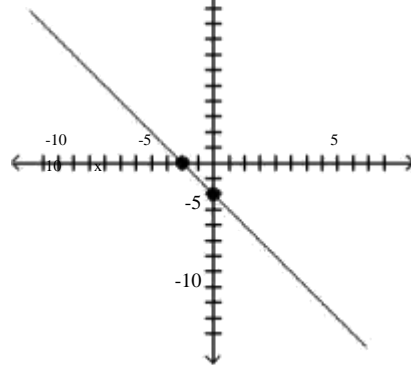
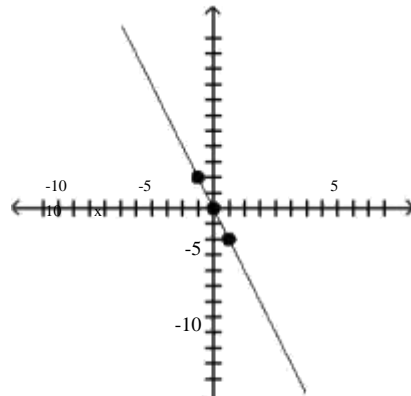
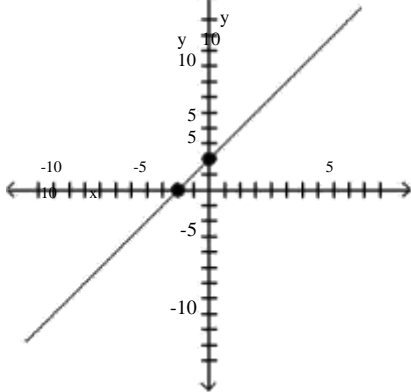

4) $y = 2x - 4$

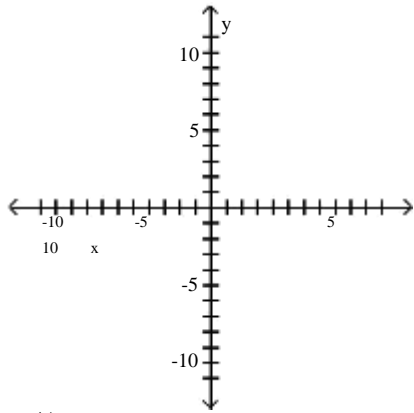

A)
B)

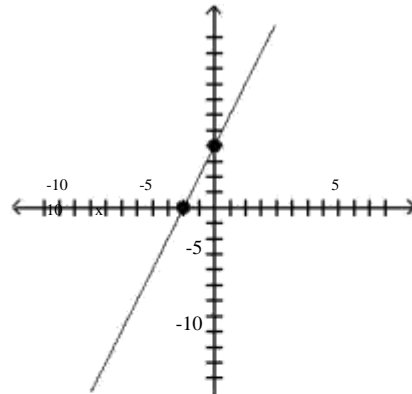
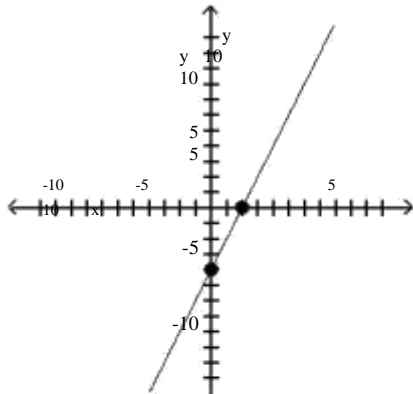

C)
D)

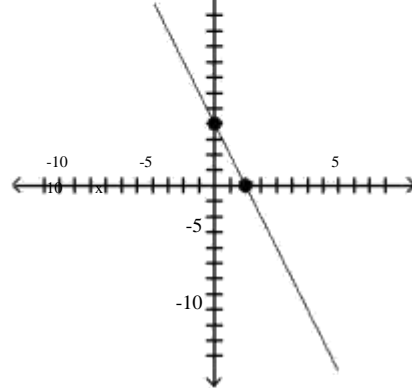
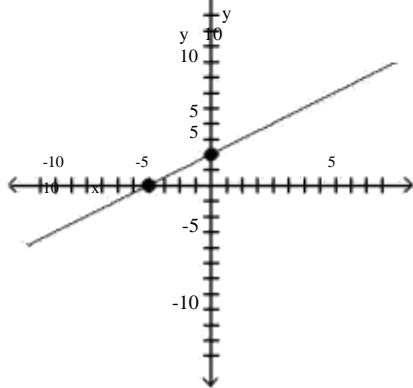

5) $y = x^2 - 9$

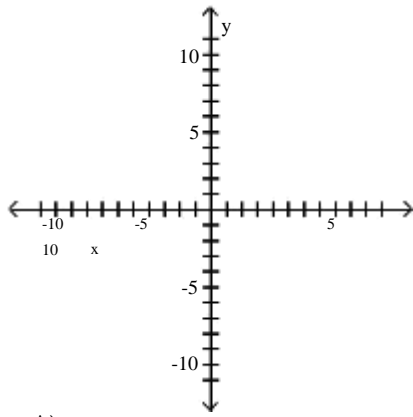

A)
B)

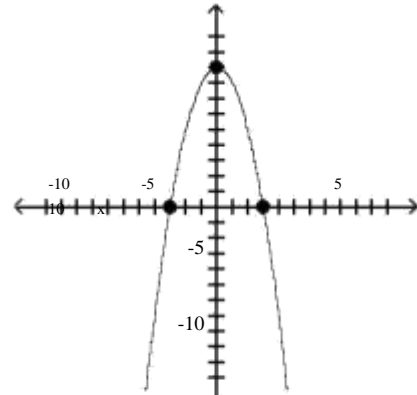
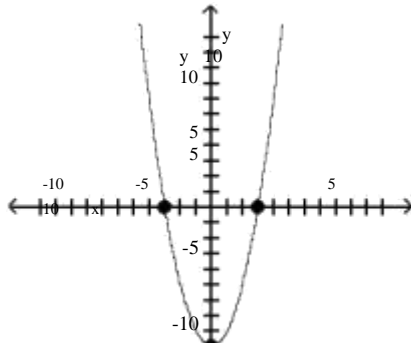

C)
D)

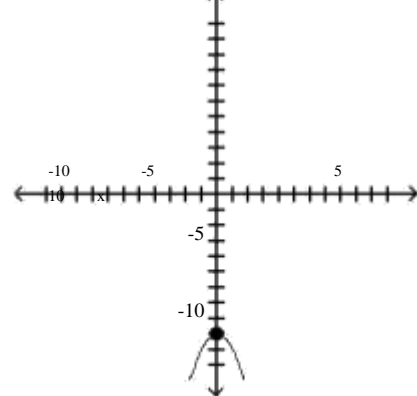
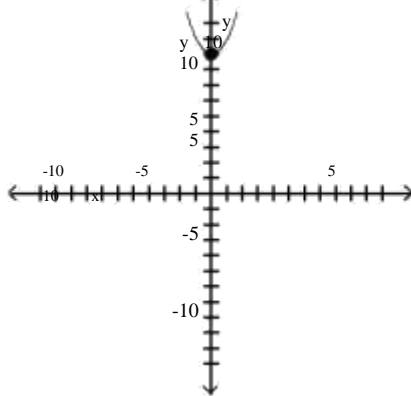

6) $4x + 2y = 8$

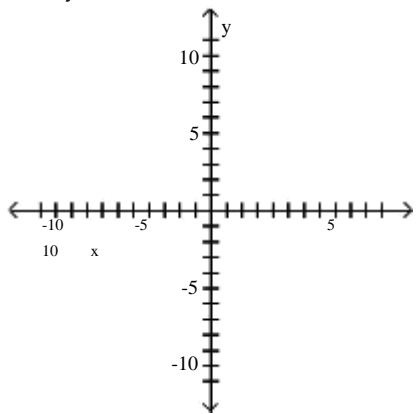

A)

B)

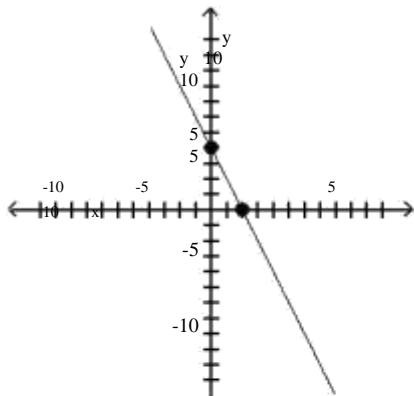

C)

D)

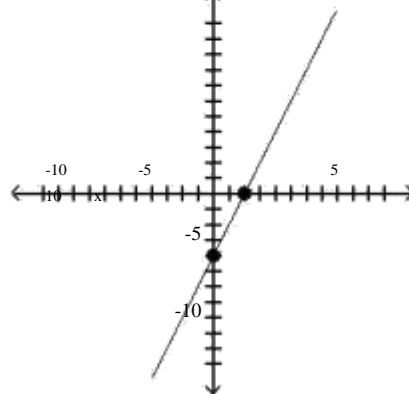
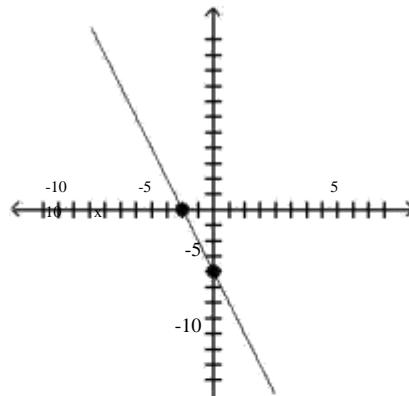
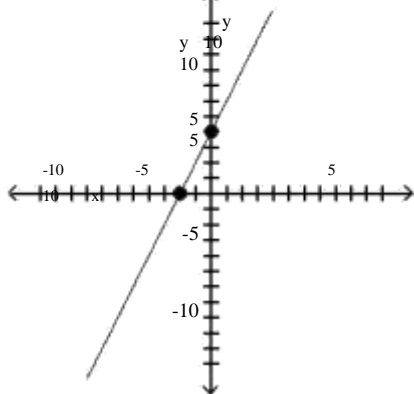

7) $4x^2 + y = 4$

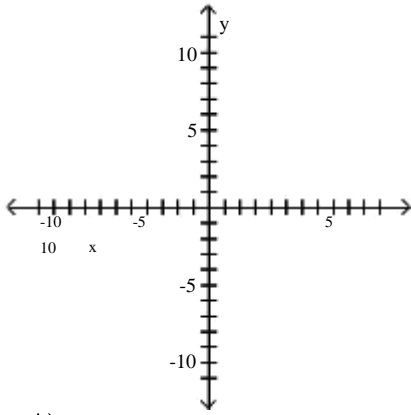

- A)
- B)

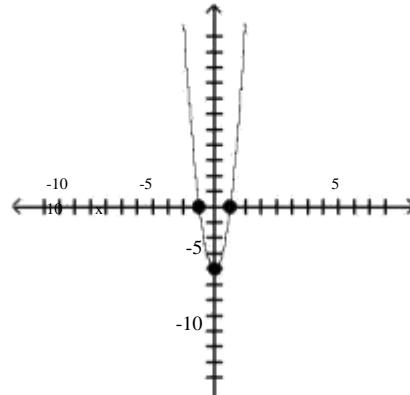
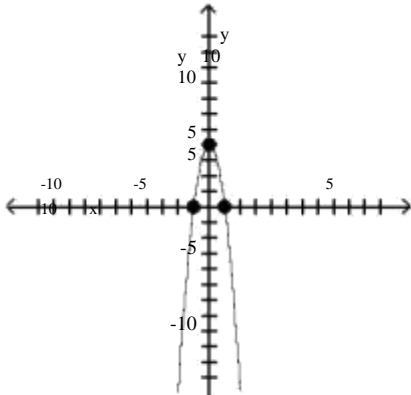

- C)
- D)

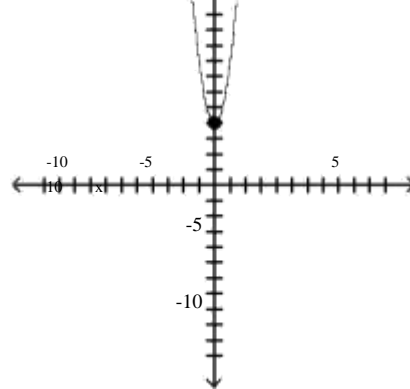
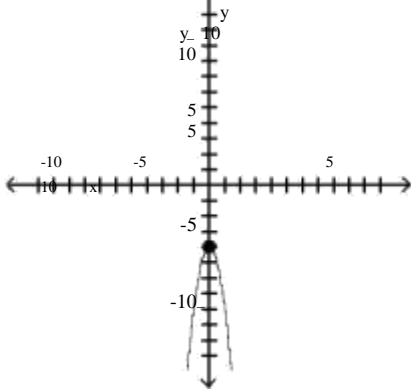

Solve the problem.

8) If $(a, 3)$ is a point on the graph of $y = 2x - 5$, what is a ?

- A) 4
 - B) 1
 - C) -1
 - D) -4
- what is b ?
- A) -4
 - B) 4
 - C) 3
 - D) $\frac{11}{3}$

- A) 4
 - B) 1
 - C) -1
 - D) -4
- 9) If $(3, b)$ is a point on the graph of $3x - 2y = 17$
- A) -4
 - B) 4
 - C) 3
 - D) $\frac{11}{3}$

10) The height of a baseball (in feet) at time t (in seconds) is given by $y = -16x^2 + 80x + 5$. Which one of the following points is not on the graph of the equation?

- A) (2, 117)
- B) (1, 69)
- C) (3, 101)
- D) (4, 69)



2 Find Intercepts from a Graph

MULTIPLE CHOICE. Choose the one alternative that best completes the statement or answers the question.

List the intercepts of the graph.

1)

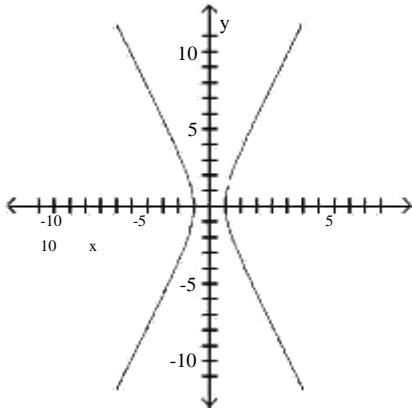

A) $(-1, 0), (1, 0)$

B) $(0, -1), (1, 0)$

C) $(0, -1), (0, 1)$

D) $(-1, 0), (0, 1)$

2)

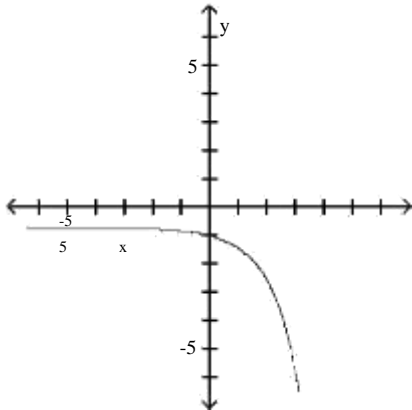

A) $(0, -1)$

B) $(0, 0)$

C) $(-1, -1)$

D) $(-1, 0)$

3)

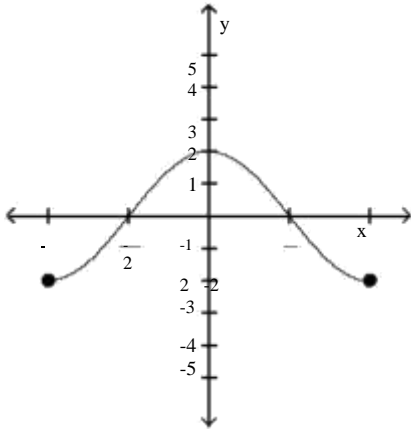

A) $\begin{cases} p = -2 \\ q = 0 \end{cases}, (0, 2), \begin{cases} p = 2 \\ q = 0 \end{cases}$ B) $\begin{cases} p = -2 \\ q = 2 \end{cases}$

C) $\begin{cases} p = 0 \\ q = -2 \end{cases}, (2, 0), \begin{cases} p = 0 \\ q = 2 \end{cases}$

D) $\begin{cases} p = -2 \\ q = 0 \end{cases}, (2, 0), \begin{cases} p = 2 \\ q = 0 \end{cases}$

4)

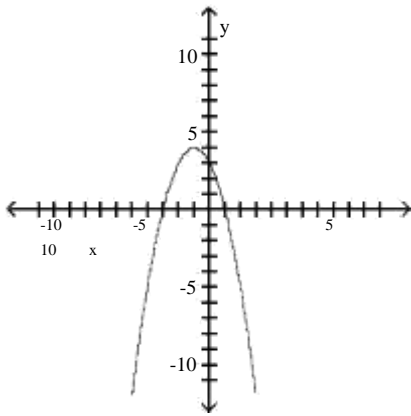

- A) (-3, 0), (0, 3), (1, 0)
 B) (-3, 0), (0, 3), (0, 1) C) (0, -3), (3, 0), (0, 1)
 D) (0, -3), (0, 3), (1, 0)

5)

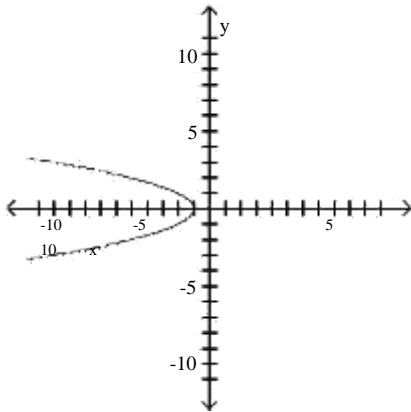

- A) (-1, 0)
 D) (0, 1)

B) (0, -1)

C) (1, 0)



6)

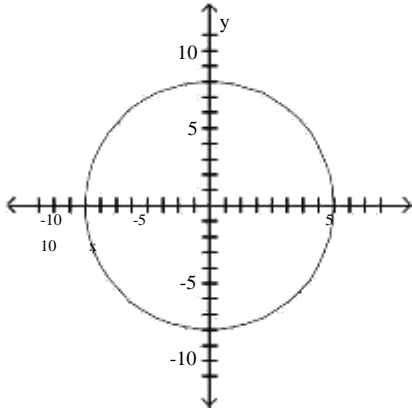

- A) $(-8, 0), (0, -8), (0, 8), (8, 0)$
- B) $(-8, 0), (0, 8)$
- C) $(-8, 0), (0, -8), (0, 0), (0, 8), (8, 0)$
- D) $(0, 8), (8, 0)$

7)

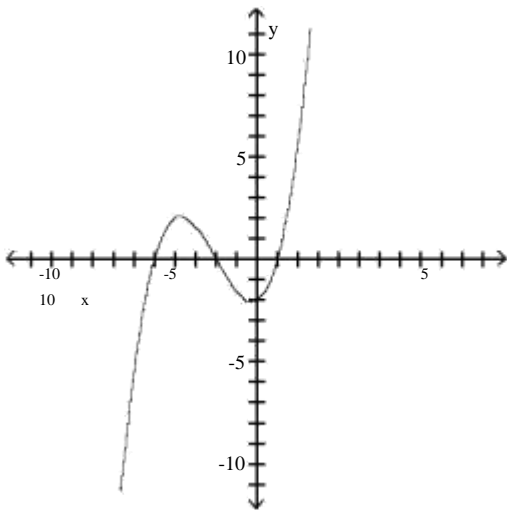

- A) $(-2, 0), (1, 0), (-5, 0), (0, -2)$
- B) $(-2, 0), (0, -2), (0, 1), (0, -5)$
- C) $(2, 0), (1, 0), (5, 0), (0, -2)$
- D) $(-2, 0), (0, 2), (0, 1), (0, 5)$

8)

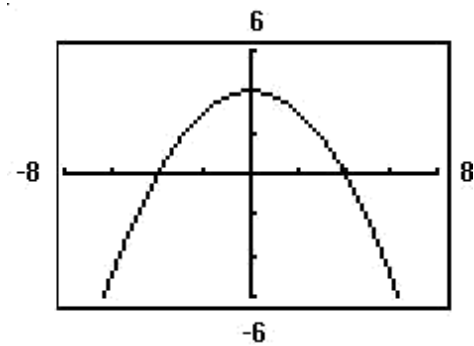

- A) $(-4, 0), (0, 4), (4, 0), (-2, 0), (2, 0)$
- B) $(-2, 0), (0, 2), (2, 0)$
- C) $(-2, 0), (0, 4), (2, 0)$
- D)



3 Find Intercepts from an Equation

MULTIPLE CHOICE. Choose the one alternative that best completes the statement or answers the question.

List the intercepts for the graph of the equation.

1) $y = x + 4$

A) (-4, 0), (0, 4)

B) (4, 0), (0, -4)

C) (-4, 0), (0, -4)

D) (4, 0), (0, 4)

2) $y = -4x$

A) (0, 0)

B) (0, -4)

C) (-4, 0)

D) (-4, -4)

3) $y^2 = x + 1$

A) (0, -1), (-1, 0), (0, 1)

B) (-1, 0), (0, -1), (1, 0)

C) (0, -1), (1, 0), (0, 1)

D) (1, 0), (0, 1), (0, -1)

4) $y = 6x\sqrt{\quad}$

A) (0, 0)

B) (1, 0)

C) (0, 1)

D) (1, 1)

5) $x^2 + y - 4 = 0$

A) (-2, 0), (0, 4), (2, 0)

B) (-2, 0), (0, -4), (2, 0)

C) (0, -2), (4, 0), (0, 2)

D) (2, 0), (0, 4), (0, -4)

6) $4x^2 + 16y^2 = 64$

A) (-4, 0), (0, -2), (0, 2), (4, 0)

B) (-2, 0), (-4,

0), (4, 0), (2, 0) C) (-16, 0), (0, -4), (0, 4), (16, 0)

D) (-4, 0), (-16, 0), (16, 0), (4, 0)

7) $9x^2 + y^2 = 9$

A) (-1, 0), (0, -3), (0, 3), (1, 0)

B) (-1, 0),

(0, -9), (0, 9), (1, 0) C) (-3, 0), (0, -1), (0, 1), (3, 0)

D) (-9, 0), (0, -1), (0, 1), (9, 0)

8) $y = x^3 - 64$

A) (0, -64), (4, 0)

B) (-64, 0), (0, 4)

C) (0, -4), (0, 4)

D) (0, -4), (-4, 0)

9) $y = x^4 - 16$

A) (0, -16), (-2, 0), (2, 0)

B) (0, -16) C) (0, 16), (-2, 0), (2, 0)

D) (0, 16)

10) $y = x^2 + 12x + 32$

A) (-8, 0), (-4, 0), (0, 32)

B) (8, 0), (4, 0), (0, 32) C) (0, -8), (0, -4), (32, 0)

D) (0, 8), (0, 4), (32, 0)

11) $y = x^2 + 4$

A) (0, 4)

B) (0, 4), (-2, 0), (2, 0) C) (4, 0), (0, -2), (0, 2)

D) (4, 0)

12) $y = \frac{6x}{x^2 + 36}$

A) (0, 0)

B) (-6, 0), (0, 0), (6, 0) C) (-36, 0), (0, 0), (36, 0)

D) (0, -6), (0, 0), (0, 6)

$$13) y = \frac{x^2 - 64}{8x^4}$$

A) (-8, 0), (8, 0)

B) (0, 0)

C) (-64, 0), (0, 0), (64, 0)

D) (0, -8), (0, 8)



4 Test an Equation for Symmetry with Respect to the x-Axis, the y-Axis, and the Origin

MULTIPLE CHOICE. Choose the one alternative that best completes the statement or answers the question.

Plot the point A. Plot the point B that has the given symmetry with point A. 1)

$A = (5, 1)$; B is symmetric to A with respect to the origin

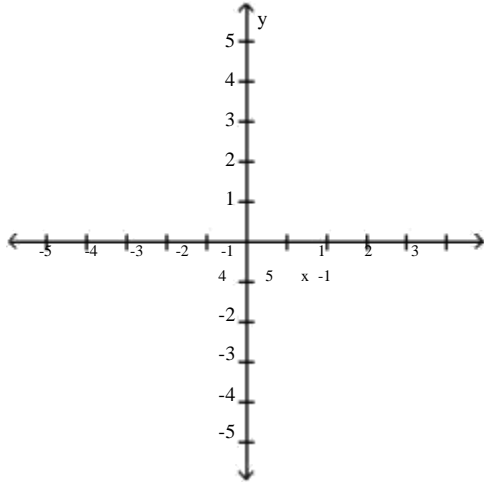

A)

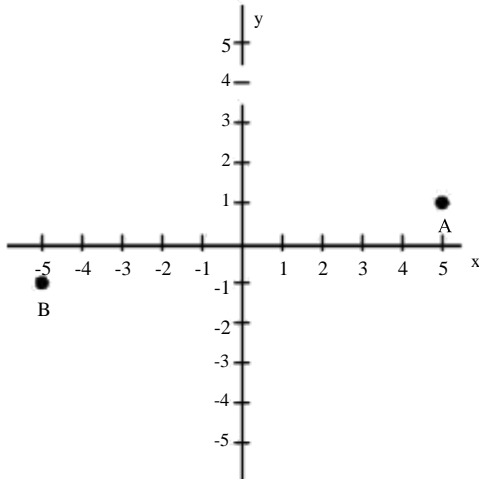

B)

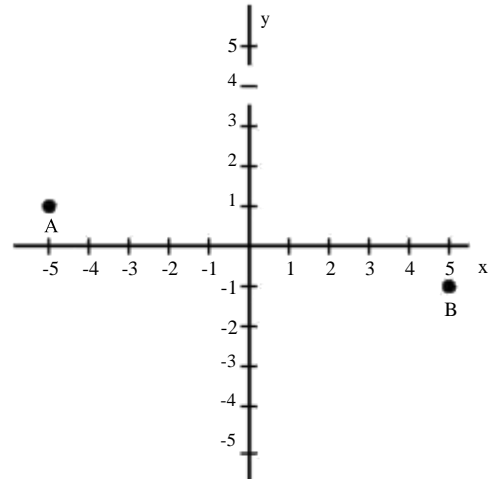

C)

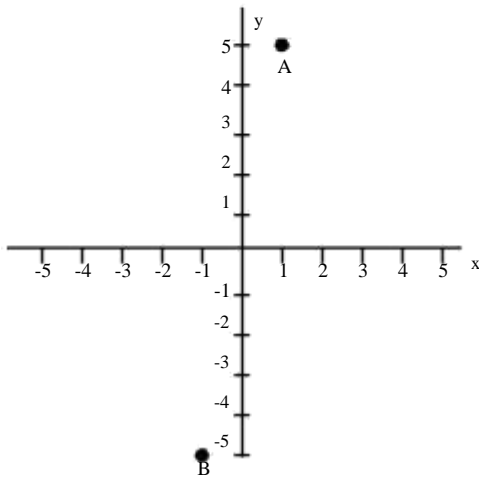

D)

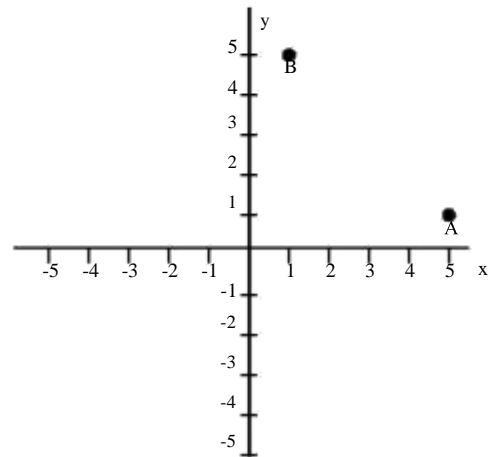

2) $A = (0, 1)$; B is symmetric to A with respect to the origin

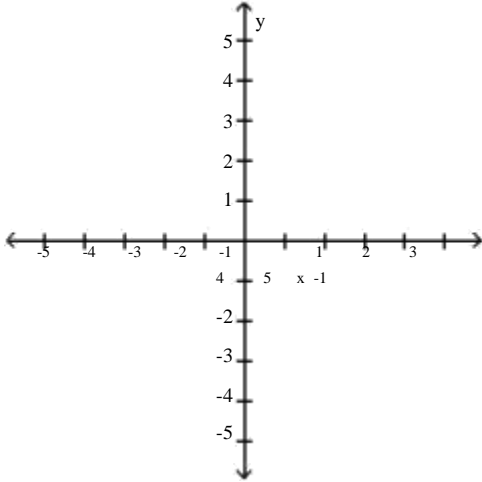

A)
B)

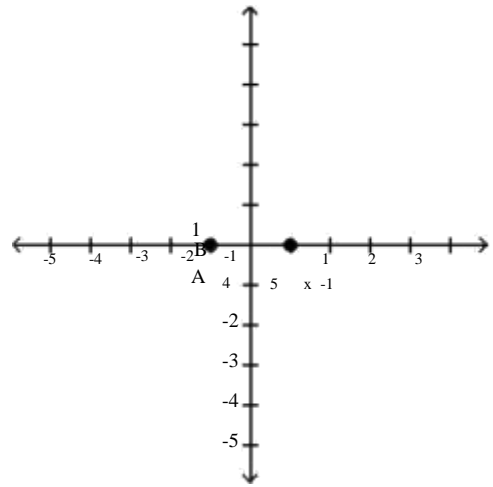
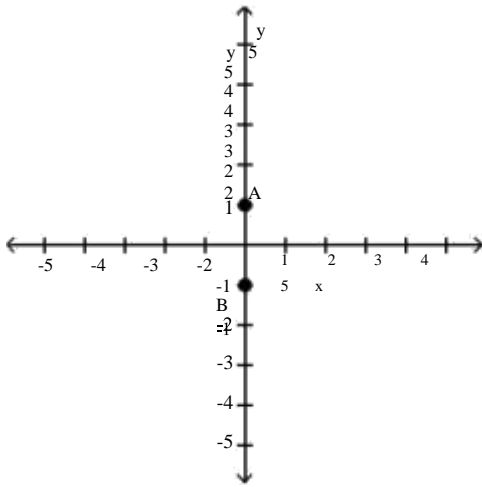

C)
D)

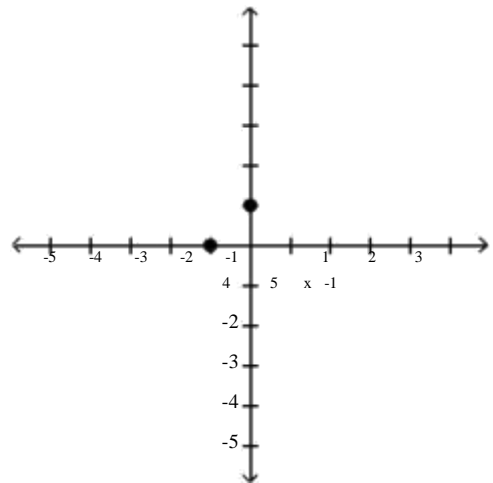
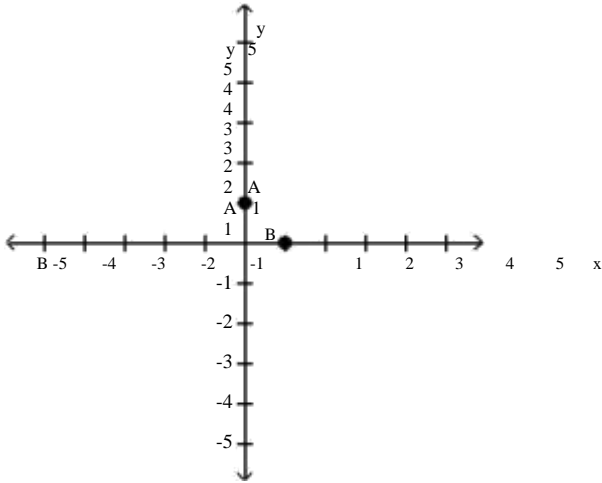

List the intercepts of the graph. Tell whether the graph is symmetric with respect to the x-axis, y-axis, origin, or none of these.

3)

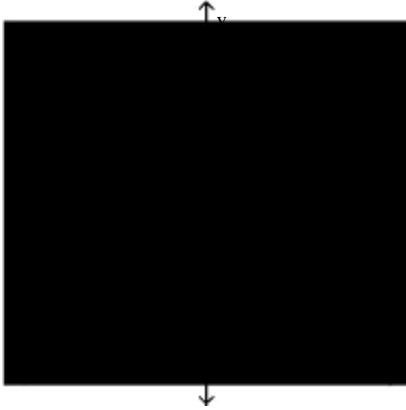

- A) intercepts: $(-2, 0)$ and $(2, 0)$
symmetric with respect to x-axis, y-axis, and origin
- B) intercepts: $(-2, 0)$ and $(2, 0)$
symmetric with respect to origin
- C) intercepts: $(0, -2)$ and $(0, 2)$
symmetric with respect to x-axis, y-axis, and origin
- D) intercepts: $(0, -2)$ and $(0, 2)$
symmetric with respect to y-axis

4)

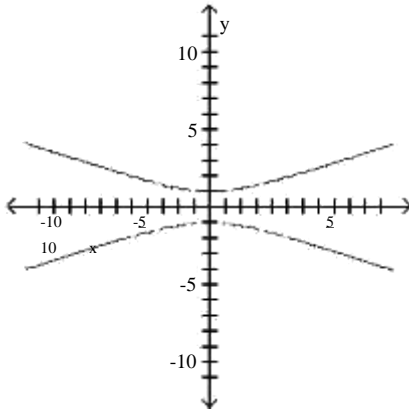

- A) intercepts: $(0, 1)$ and $(0, -1)$
symmetric with respect to x-axis, y-axis, and origin
- B) intercepts: $(0, 1)$ and $(0, -1)$
symmetric with respect to origin
- C) intercepts: $(1, 0)$ and $(-1, 0)$
symmetric with respect to x-axis, y-axis, and origin
- D) intercepts: $(1, 0)$ and $(-1, 0)$
symmetric with respect to y-axis



5)

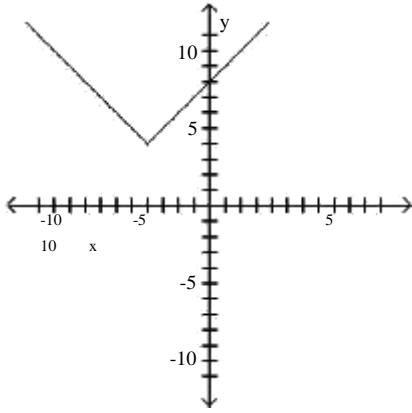

- A) intercept: (0, 8)
no symmetry
- C) intercept: (0, 8)
symmetric with respect to x-axis

- B) intercept: (8, 0)
no symmetry
- D) intercept: (8, 0)
symmetric with respect to y-axis

6)

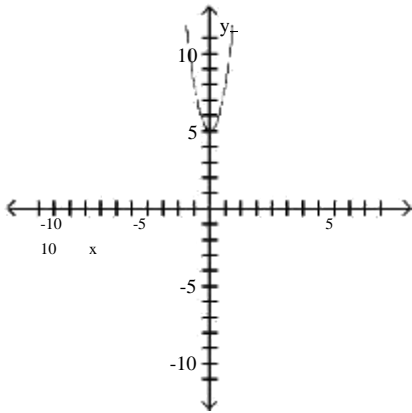

- A) intercept: (0, 5)
symmetric with respect to y-axis
- C) intercept: (5, 0)
symmetric with respect to y-axis

- B) intercept: (0, 5)
symmetric with respect to origin
- D) intercept: (5, 0)
symmetric with respect to x-axis



7)

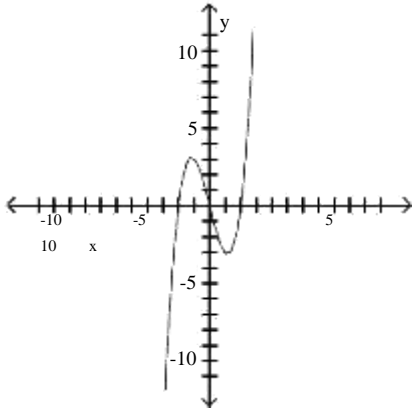

- A) intercepts: $(-2, 0)$, $(0, 0)$, $(2, 0)$
symmetric with respect to origin
- B) intercepts: $(-2, 0)$, $(0, 0)$, $(2, 0)$
symmetric with respect to x-axis
- C) intercepts: $(-2, 0)$, $(0, 0)$, $(2, 0)$
symmetric with respect to y-axis
- D) intercepts: $(-2, 0)$, $(0, 0)$, $(2, 0)$
symmetric with respect to x-axis, y-axis, and origin

Draw a complete graph so that it has the given type of symmetry. 8)
Symmetric with respect to the y-axis

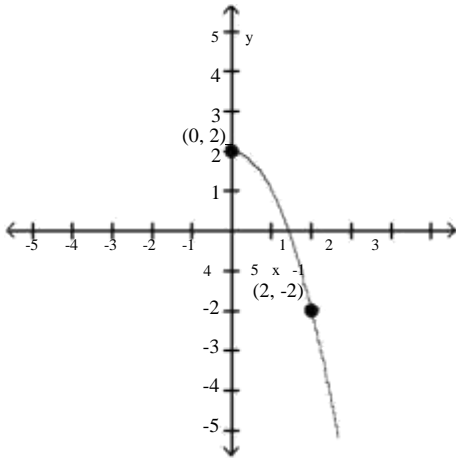

A)

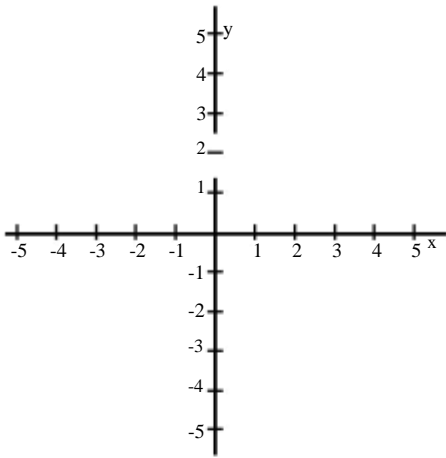

B)

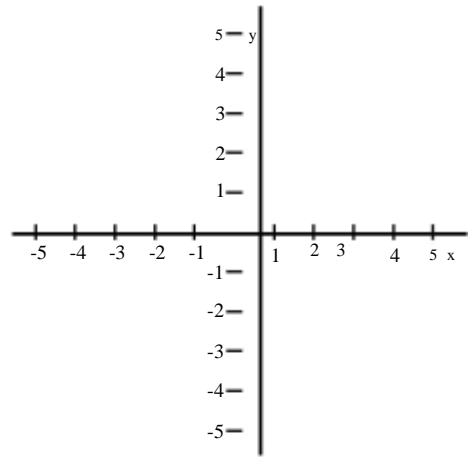

C)

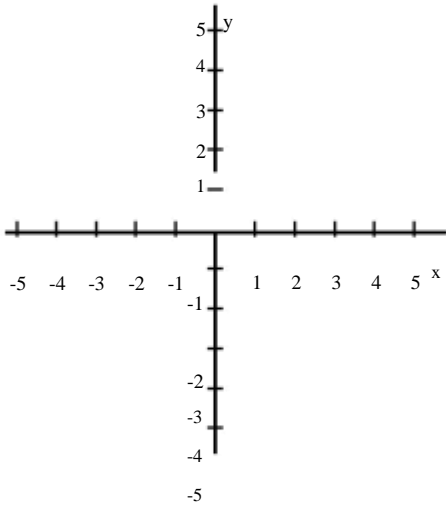

D)

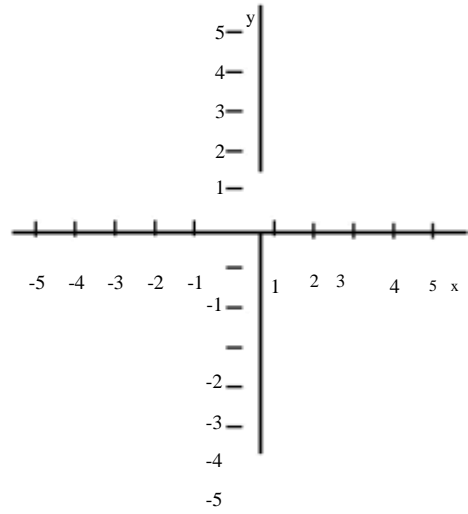

9) origin

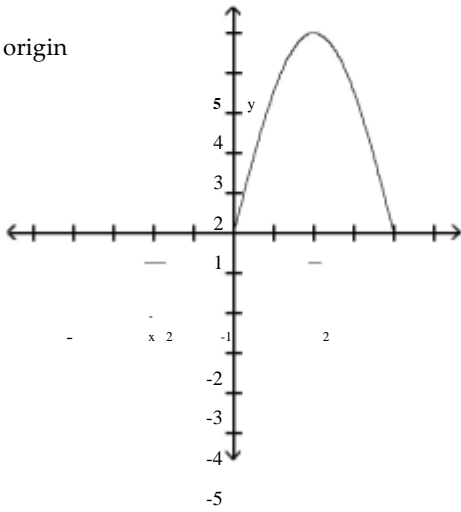

A)
B)

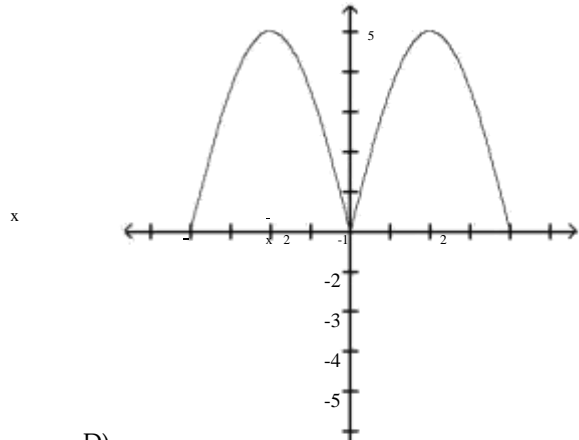
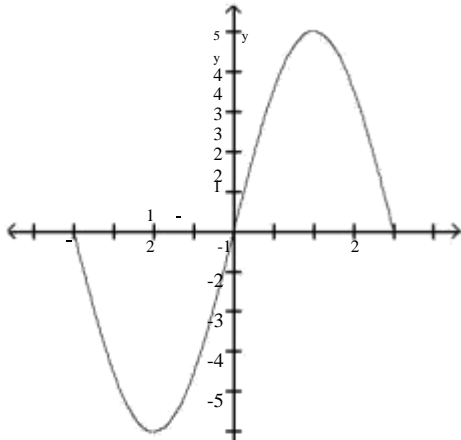

C)

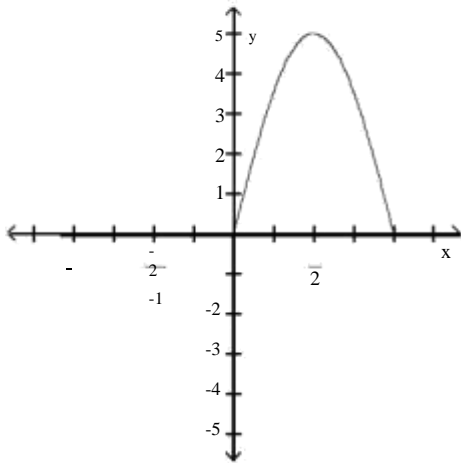

D)

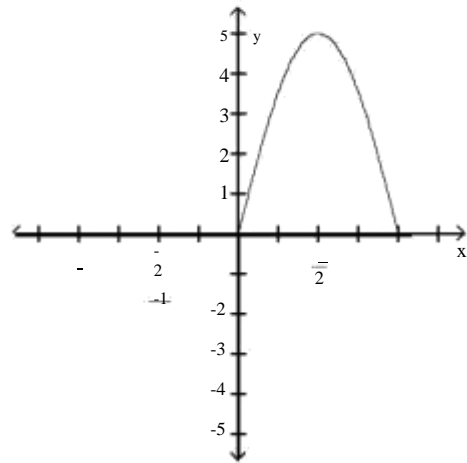

10) Symmetric with respect to the x-axis

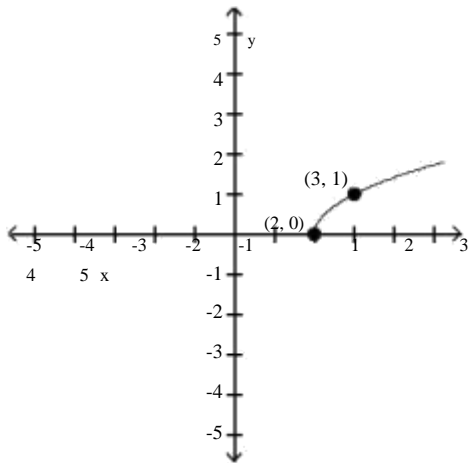

A)

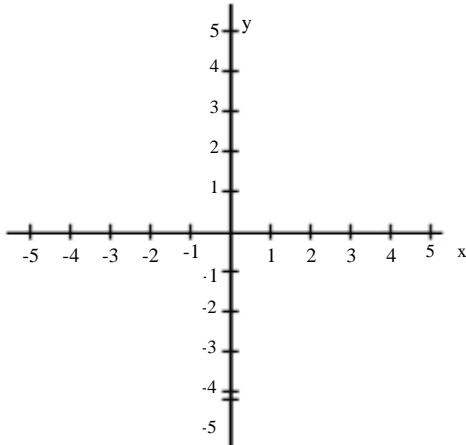

B)

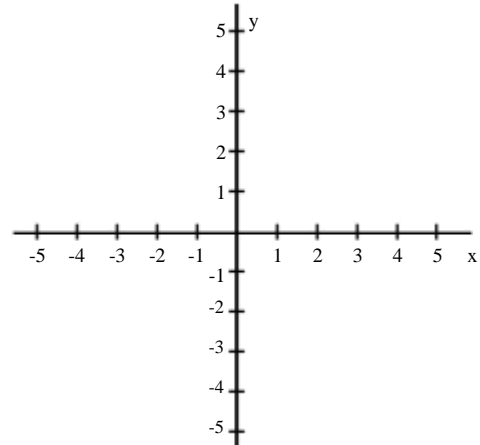

C)

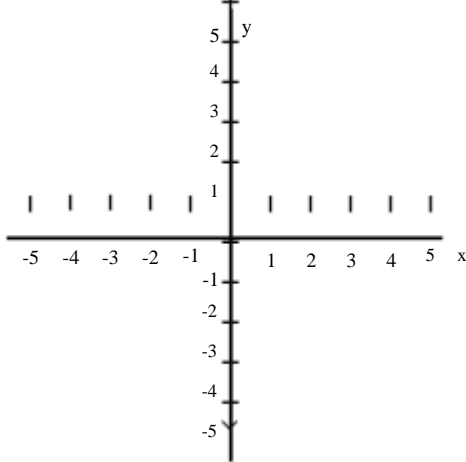

D)

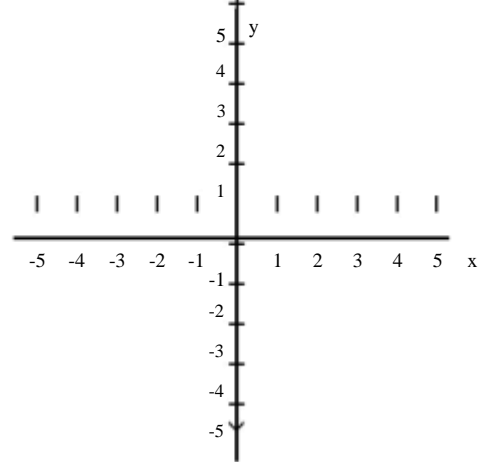

List the intercepts and type(s) of symmetry, if any.

11) $y^2 = x + 1$

A) intercepts: $(-1, 0)$, $(0, 1)$, $(0, -1)$
 symmetric with respect to x-axis

C) intercepts: $(0, -1)$, $(1, 0)$, $(-1, 0)$
 symmetric with respect to y-axis

B) intercepts: $(1, 0)$, $(0, 1)$, $(0, -1)$
 symmetric with respect to x-axis

D) intercepts: $(0, 1)$, $(1, 0)$, $(-1, 0)$
 symmetric with respect to y-axis

12) $16x^2 + y^2 = 16$

A) intercepts: $(1, 0)$, $(-1, 0)$, $(0, 4)$, $(0, -4)$
 symmetric with respect to x-axis, y-axis, and origin B)

intercepts: $(4, 0)$, $(-4, 0)$, $(0, 1)$, $(0, -1)$
 symmetric with respect to x-axis and y-axis

C) intercepts: $(1, 0)$, $(-1, 0)$, $(0, 4)$, $(0, -4)$
 symmetric with respect to x-axis and y-axis

D) intercepts: $(4, 0)$, $(-4, 0)$, $(0, 1)$, $(0, -1)$
 symmetric with respect to the origin

$$13) y = \frac{-5}{x^2 - 9}$$

- A) intercept: (0, 0)
symmetric with respect to origin
C) intercept: (0, 0)
symmetric with respect to x-axis

- B) intercepts: (3, 0), (-3, 0), (0, 0)
symmetric with respect to origin
D) intercept: (0, 0)
symmetric with respect to y-axis

Determine whether the graph of the equation is symmetric with respect to the x-axis, the y-axis, and/or the origin. 14) $y = x - 1$

- A) x-axis
B) y-axis
C) origin
D) x-axis, y-axis, origin
E) none

$$15) y = 2x$$

- A) origin
B) x-axis
C) y-axis
D) x-axis, y-axis, origin
E) none

$$16) x^2 + y - 36 = 0$$

- A) y-axis
B) x-axis
C) origin
D) x-axis, y-axis, origin
E) none

$$17) y^2 - x - 25 = 0$$

- A) x-axis
B) y-axis
C) origin
D) x-axis, y-axis, origin
E) none

$$18) 4x^2 + 16y^2 = 64$$

- A) origin
B) x-axis
C) y-axis
D) x-axis, y-axis, origin
E) none

$$19) 9x^2 + y^2 = 9$$

- A) origin
B) x-axis
C) y-axis
D) x-axis, y-axis, origin
E) none



20) $y = x^2 + 15x + 56$

- A) x-axis
- B) y-axis
- C) origin
- D) x-axis, y-axis, origin
- E) none

21) $y = \frac{5x}{x^2 + 25}$

- A) origin
- B) x-axis
- C) y-axis
- D) x-axis, y-axis, origin
- E) none

22) $y = \frac{x^2 - 49}{7x^4}$

- A) y-axis
- B) x-axis
- C) origin
- D) x-axis, y-axis, origin
- E) none

23) $y = 2x^2 - 1$

- A) y-axis
- B) x-axis
- C) origin
- D) x-axis, y-axis, origin
- E) none

24) $y = (x - 9)(x + 4)$

- A) x-axis
- B) y-axis
- C) origin
- D) x-axis, y-axis, origin
- E) none

25) $y = -8x^3 + 4x$

- A) origin
- B) x-axis
- C) y-axis
- D) x-axis, y-axis, origin
- E) none

26) $y = -7x^4 + 7x + 9$

- A) origin
- B) x-axis
- C) y-axis
- D) x-axis, y-axis, origin
- E) none



2) $x = y^2$

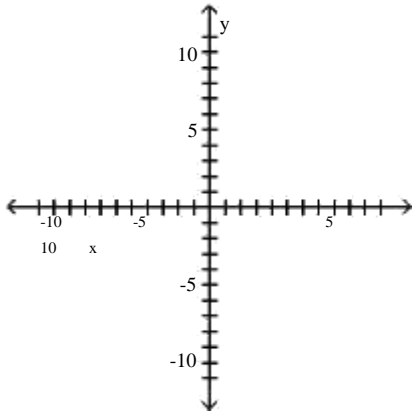

A)

B)

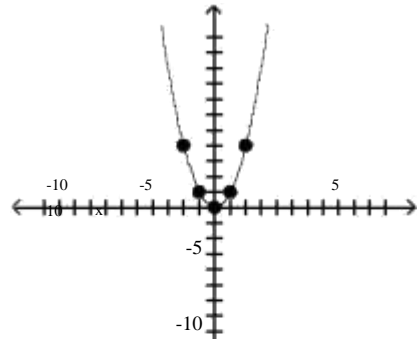
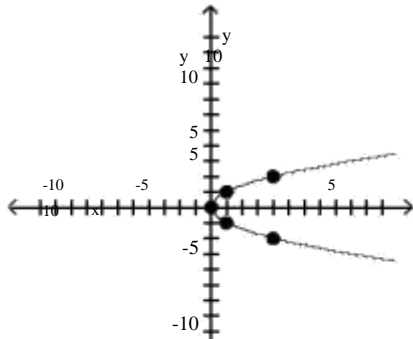

C)

D)

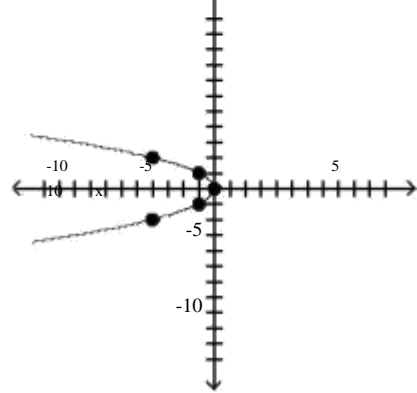
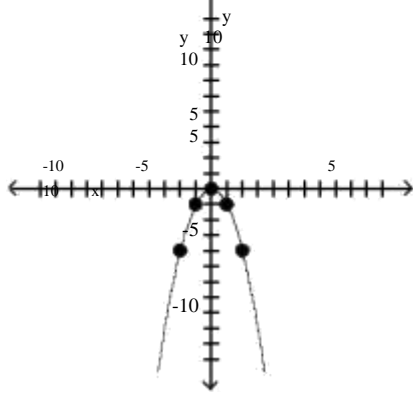

3) $y = \sqrt{x}$

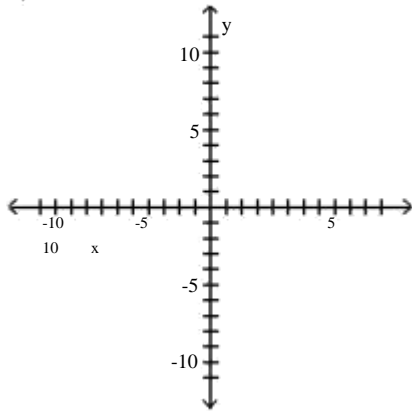

A)

B)

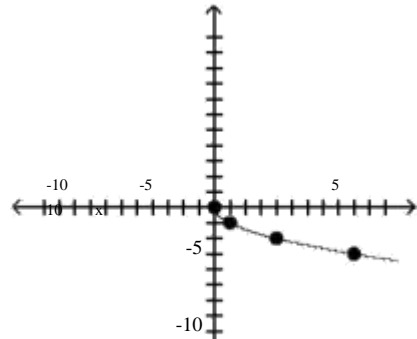
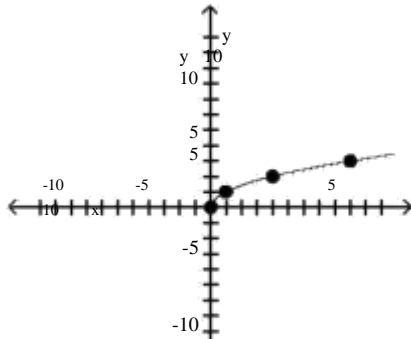

C)

D)

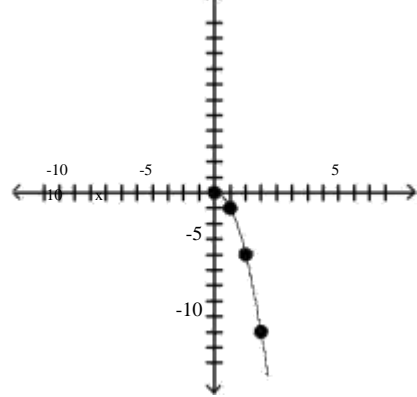
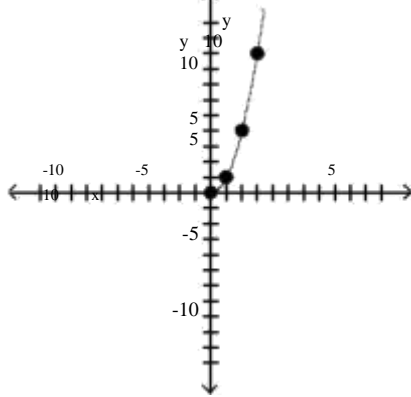

4) $y = \frac{1}{x}$

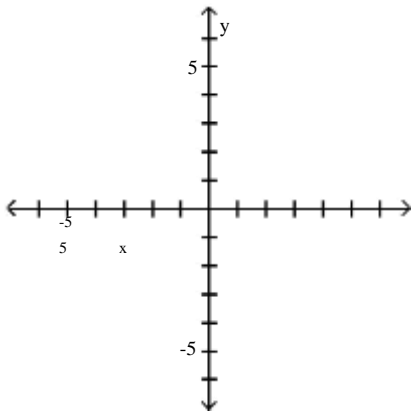

A)
B)

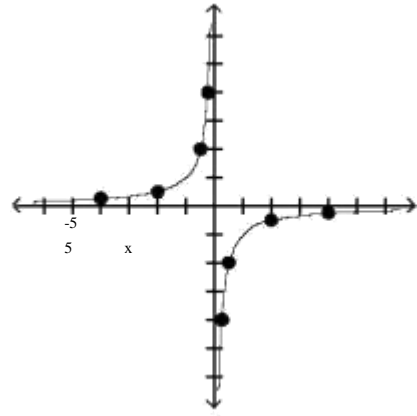
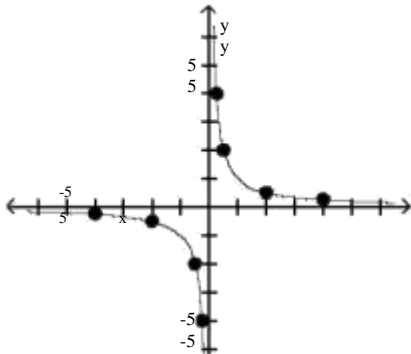

C)
D)

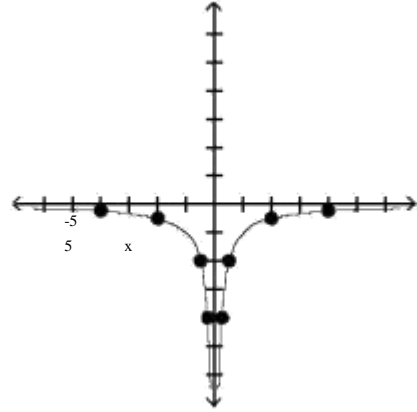
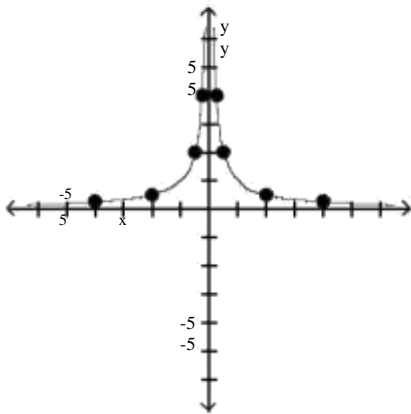

2.3 Lines

1 Calculate and Interpret the Slope of a Line

MULTIPLE CHOICE. Choose the one alternative that best completes the statement or answers the question.

Find the slope of the line through the points and interpret the slope. 1)

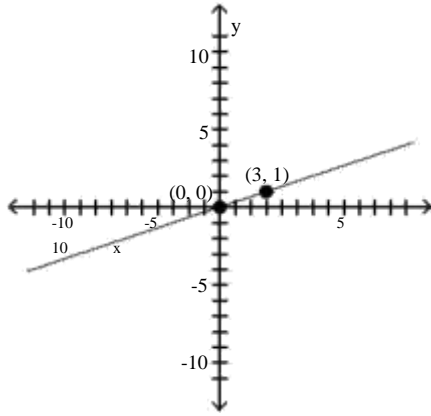

- A) $\frac{1}{3}$; for every 3-unit increase in x , y will increase by 1 unit
- B) 3; for every 1-unit increase in x , y will increase by 3 units
- C) $-\frac{1}{3}$; for every 3-unit increase in x , y will decrease by 1 unit
- D) -3; for every 1-unit increase in x , y will decrease by 3 units

Find the slope of the line.

2)

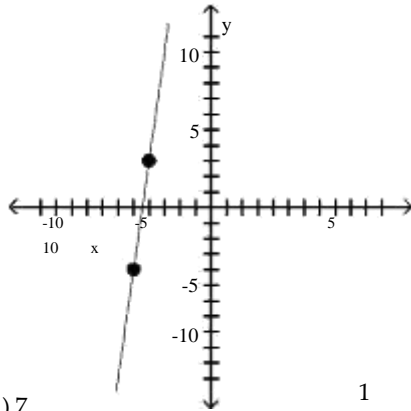

- | | | | |
|------|---|-------|---|
| A) 7 | 1 | C) -7 | 1 |
| B) | 7 | D) - | 7 |

3)

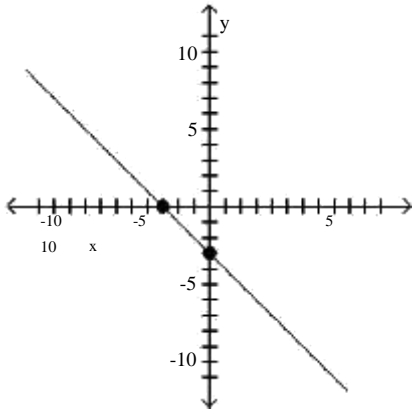

- A) -1
- C) -3

- B) 1
- D) 3

4)

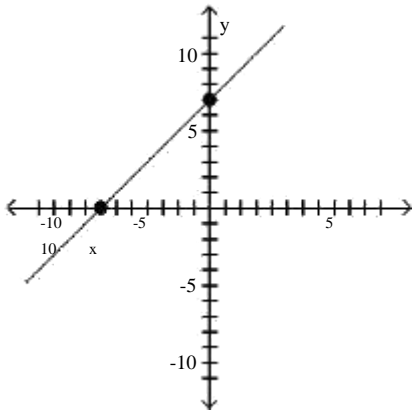

- A) 1
- C) -7

- B) -1
- D) 7

5)

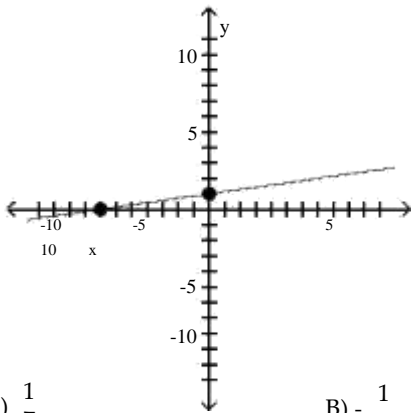

- A) $\frac{1}{7}$

- B) $-\frac{1}{7}$

- C) 7
- D) -7

Find the slope of the line containing the two points. 6)

(4, -9); (-3, 6)

- A) $-\frac{15}{7}$

- B) $\frac{15}{7}$

- C) $-\frac{7}{15}$

- D) $-\frac{7}{15}$



7) (8, 0); (0, 5)

A) $-\frac{5}{8}$

B) $\frac{5}{8}$

C) $\frac{8}{5}$

D) $-\frac{8}{5}$

8) (-3, -4); (-6, -5)

A) $\frac{1}{3}$

B) $-\frac{1}{3}$

C) 3

D) -3

9) (-3, -2); (-3, -1)

A) 1

B) -1

C) 0

10) (-8, -2); (-4, -3)

A) 0

B) $-\frac{1}{12}$

C) 12

D) undefined



2 Graph Lines Given a Point and the Slope

MULTIPLE CHOICE. Choose the one alternative that best completes the statement or answers the question.

Graph the line containing the point P and having slope m.

1) $P = (4, 6)$; $m = -\frac{13}{4}$

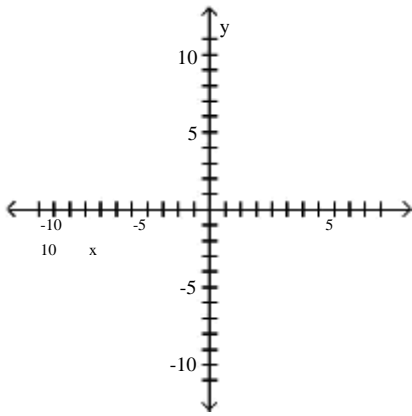

A)

B)

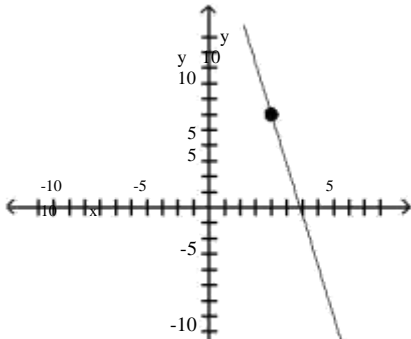

C)

D)

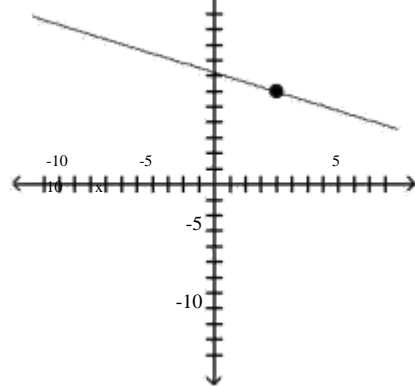
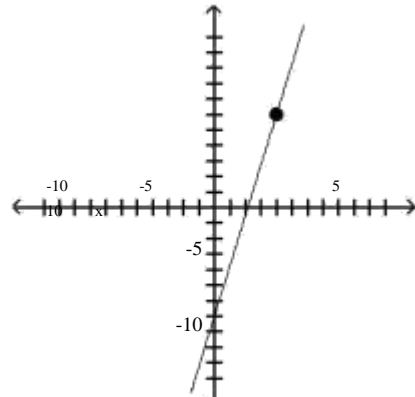
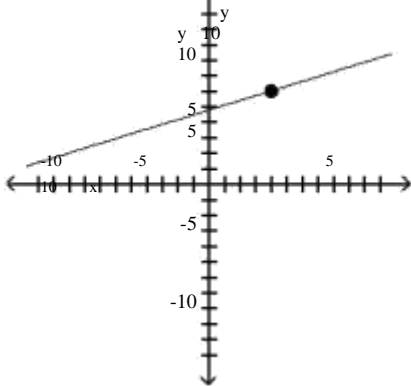

2) $P = (-5, -8)$; $m = 2$

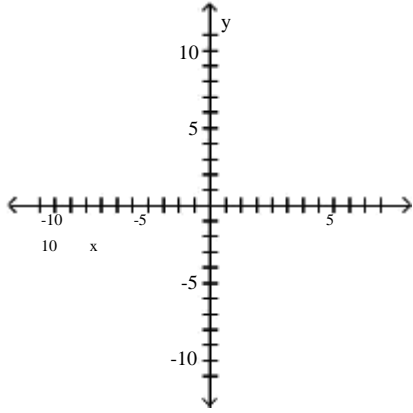

A)

B)

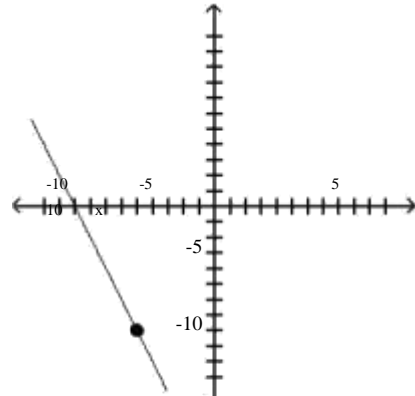
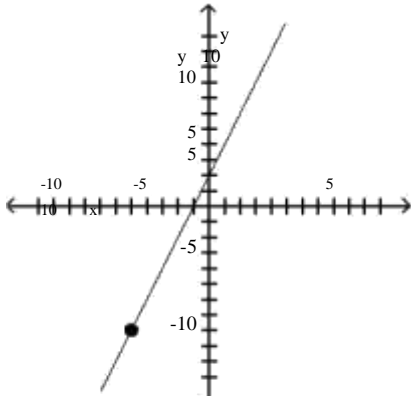

C)

D)

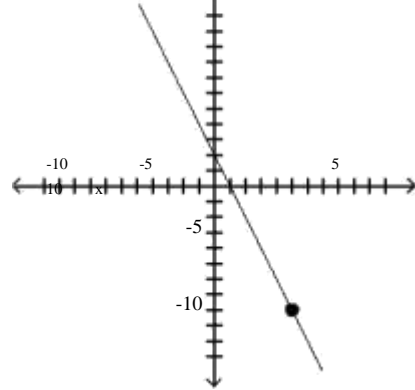
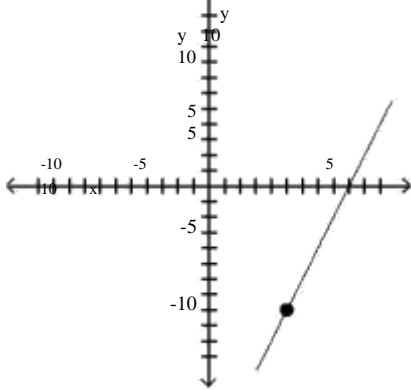

3) $P = (-3, -10)$; $m = -$

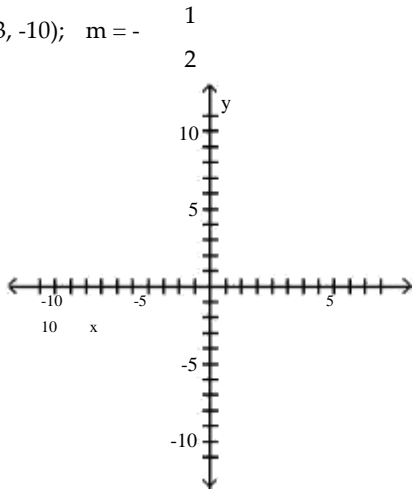

A)
B)

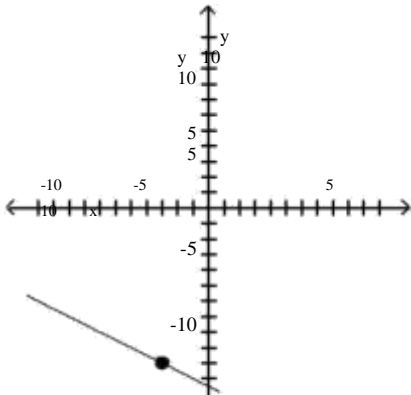

C)
D)

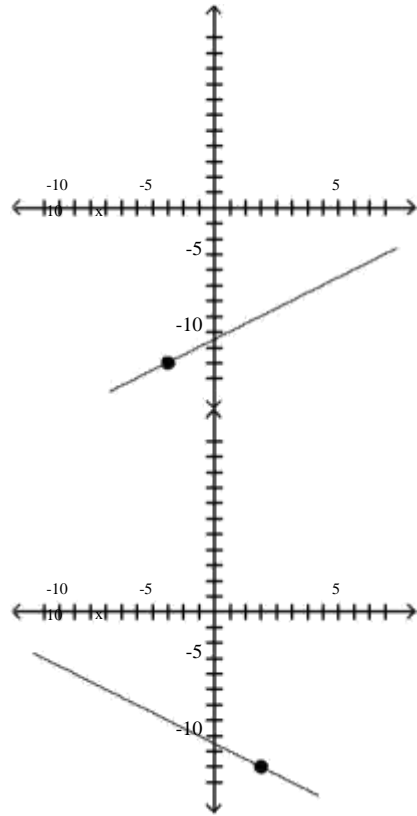
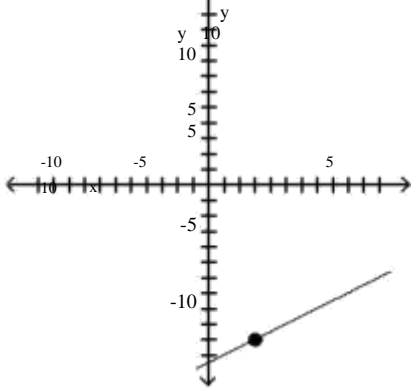

4) $P = (0, 5)$; $m = 1$

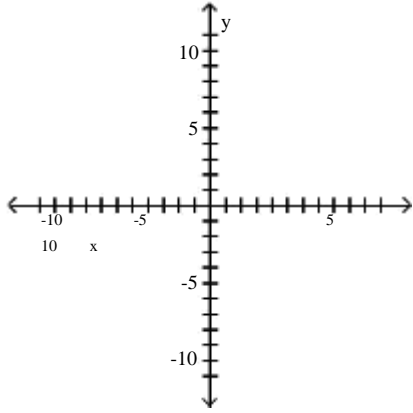

A)

B)

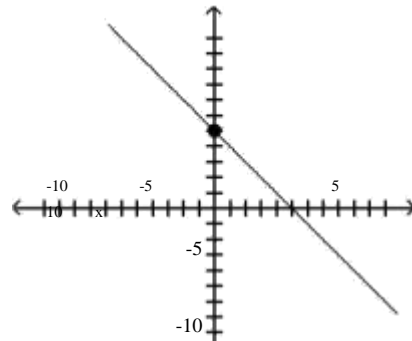
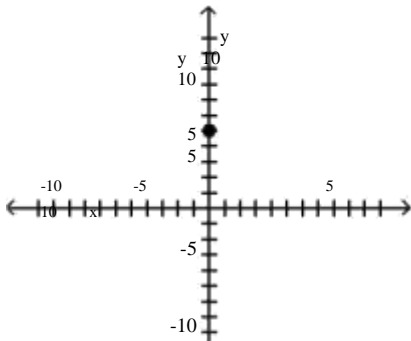

C)

D)

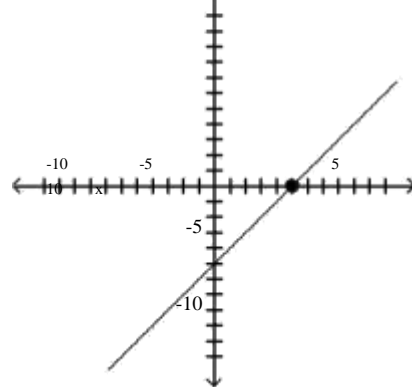
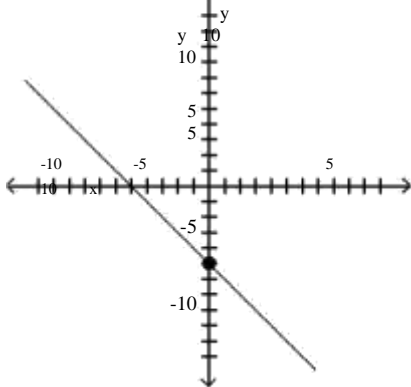

5) $P = (0, 2)$; $m = -\frac{1}{2}$

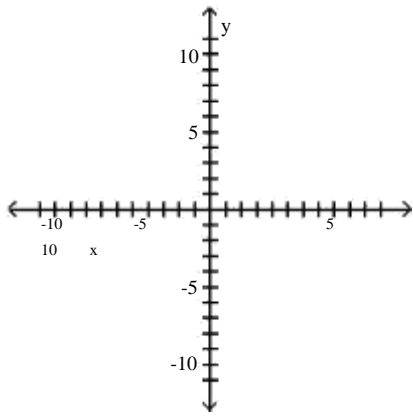

A)
B)

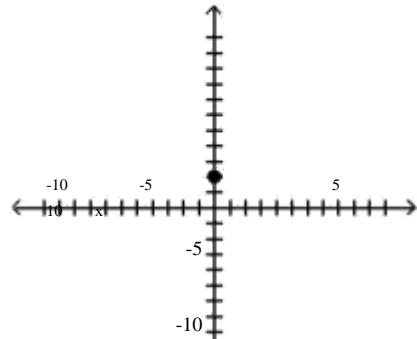
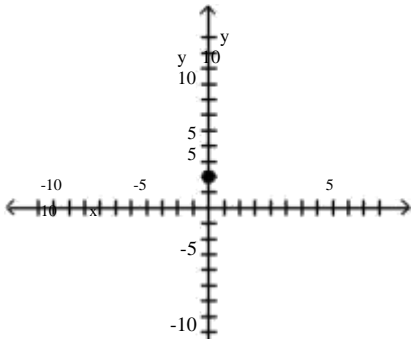

C)
D)

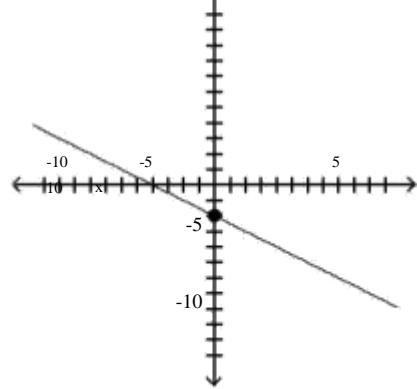
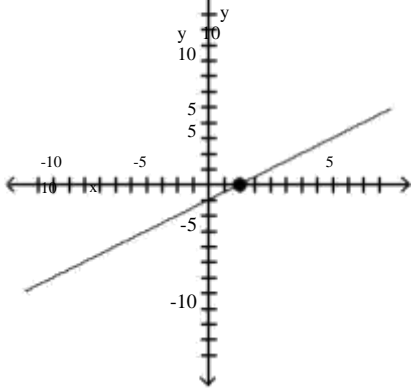

6) $P = (-4, 0)$; $m = 2$

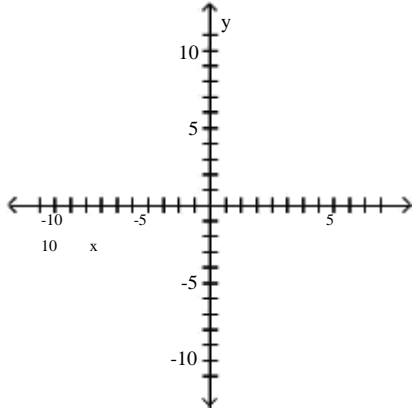

A)

B)

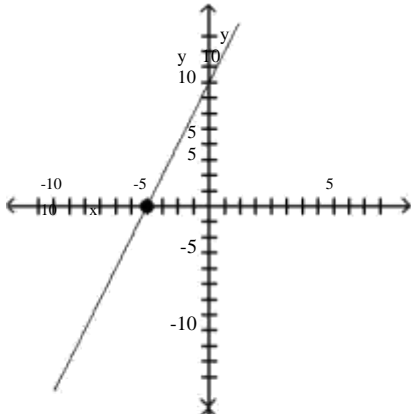

C)

D)

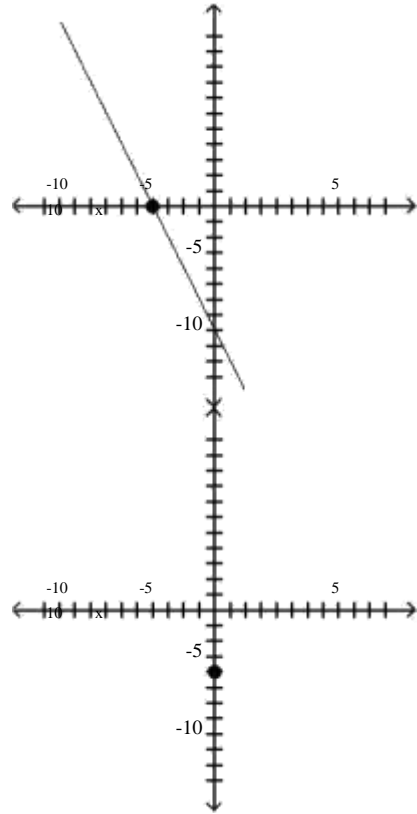
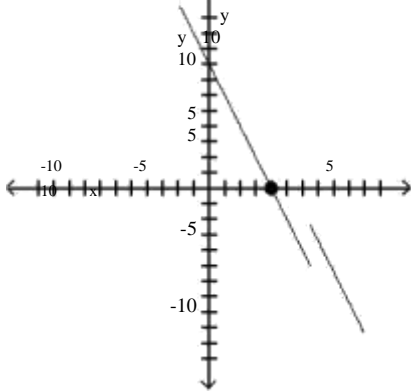

7) $P = (6, 0)$; $m = -2$

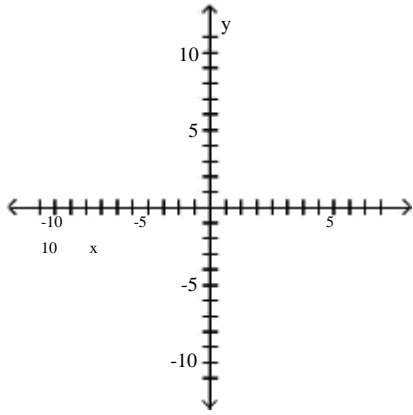

A)

B)

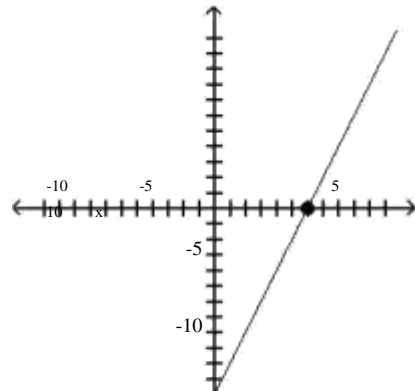
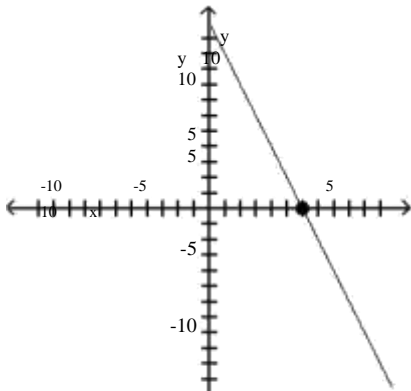

C)

D)

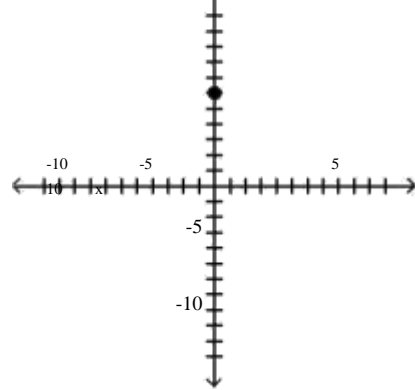
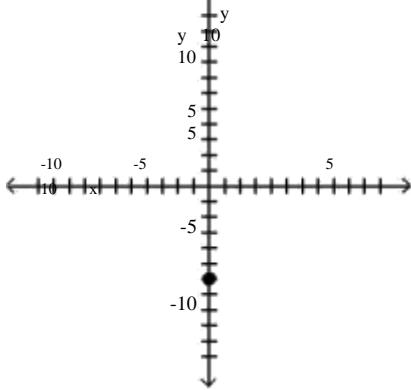

8) $P = (6, 9)$; $m = 0$

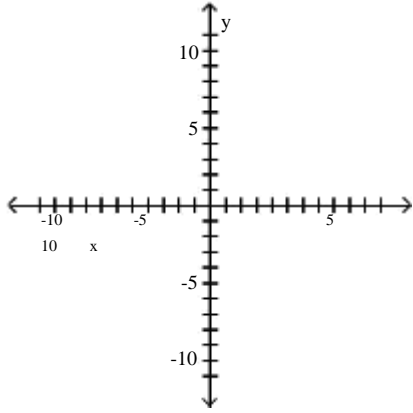

A)

B)

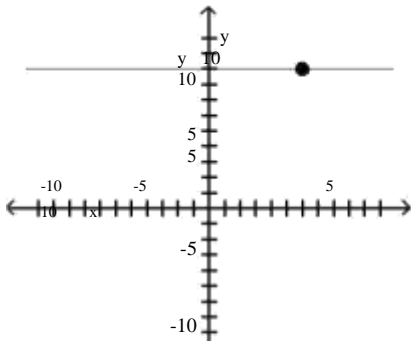

C)

D)

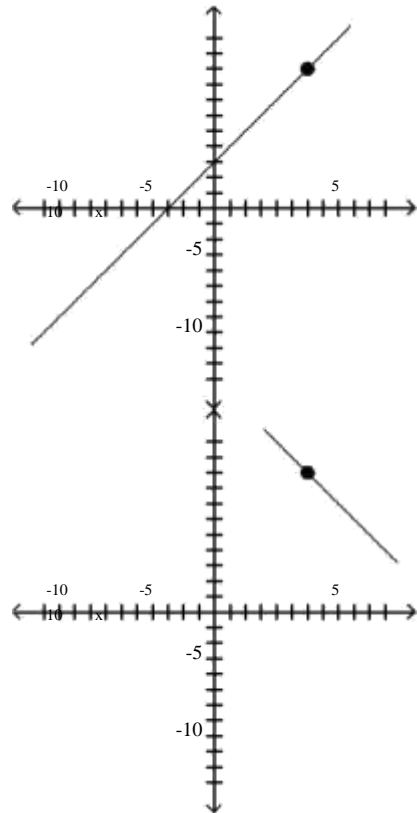
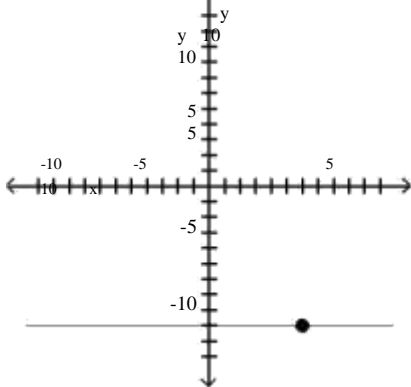

9) $P = (-1, -10)$; slope undefined

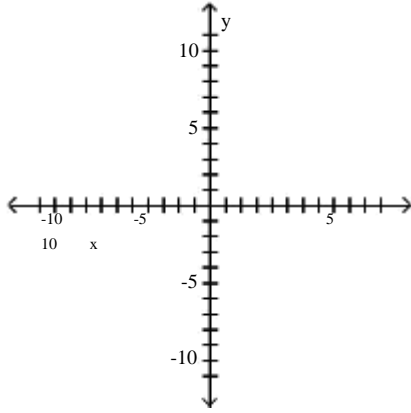

A)

B)

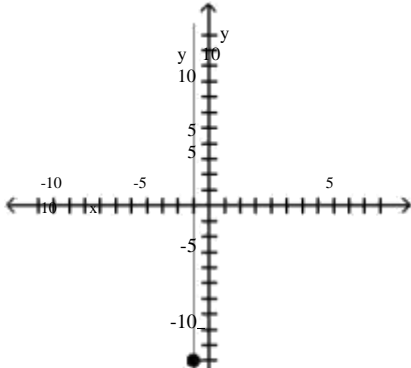

C)

D)

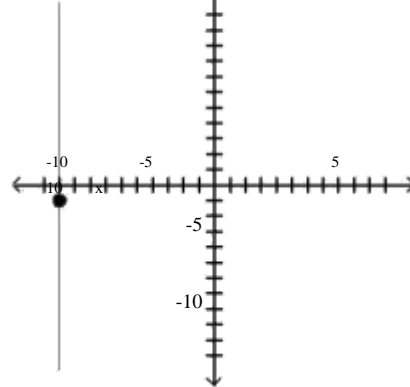
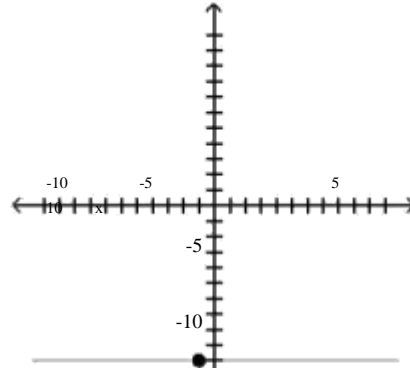
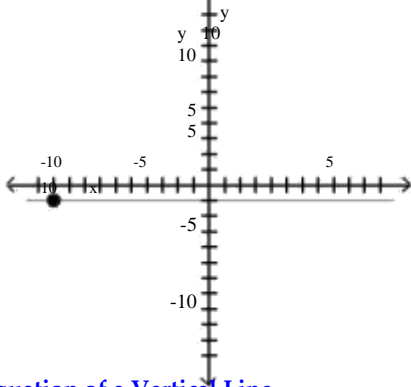

3 Find the Equation of a Vertical Line

MULTIPLE CHOICE. Choose the one alternative that best completes the statement or answers the question.

Find an equation for the line with the given properties. 1)

Slope undefined; containing the point $(-5, -6)$

A) $x = -5$

B) $y = -5$

C) $x = -6$

D) $y = -6$

2) Vertical line; containing the point $(1, -2)$

A) $x = 1$

B) $y = 1$

C) $x = -2$

D) $y = -2$



3) Slope undefined; containing the point $\left(\frac{3}{4}, 7 \right)$

A) $x = -\frac{3}{4}$

B) $y = 7$

C) $y = -$

3
4

D) $x = 7$

4) Vertical line; containing the point (2.1, 2.6)

A) $x = 2.1$

B) $x = 2.6$

C) $x = 0$

D) $x = 4.7$

4 Use the Point-Slope Form of a Line; Identify Horizontal Lines

MULTIPLE CHOICE. Choose the one alternative that best completes the statement or answers the question.

Find the slope-intercept form of the equation of the line with the given properties. 1)

Horizontal; containing the point (9, -10)

A) $y = -10$

B) $y = 9$

C) $x = -10$

D) $x = 9$

2) Slope = 0; containing the point (-6, -5)

A) $y = -5$

B) $y = -6$

C) $x = -5$

D) $x = -6$

3) Horizontal; containing the point $\left(\frac{1}{9}, 7 \right)$

A) $y = 7$

B) $y = -$

C) $y = 0$

D) $y = -7$

4) Horizontal; containing the point (5.2, -4.9)

A) $y = -4.9$

B) $y = 5.2$

C) $y = 0.3$

D) $y = 0$

Find the slope of the line and sketch its graph.

5) $y - 5 = 0$

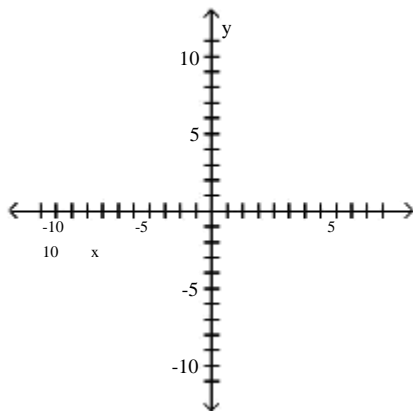

A) slope = 0

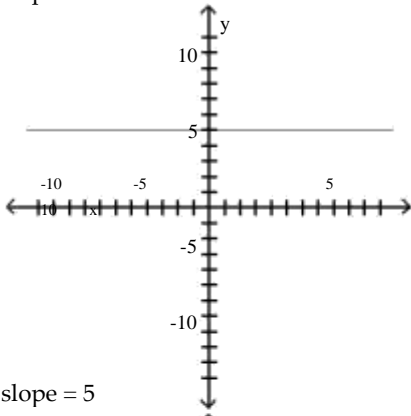

B) slope is undefined

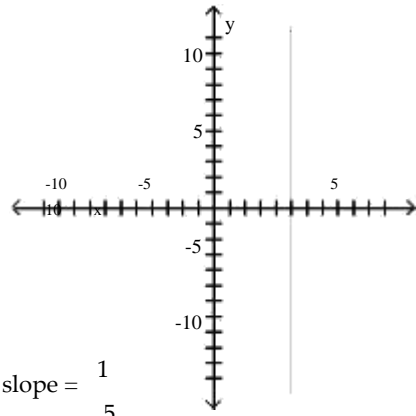

C) slope = 5

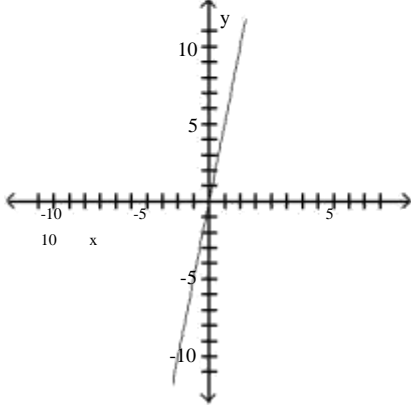

D) slope = $\frac{1}{5}$

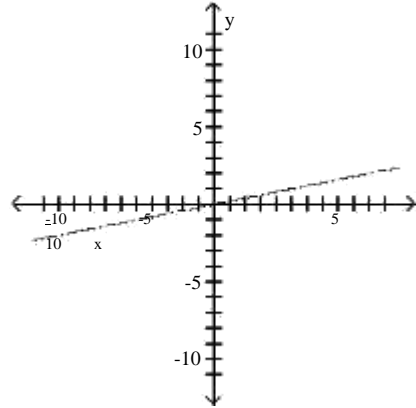

5 Find the Equation of a Line Given Two Points

MULTIPLE CHOICE. Choose the one alternative that best completes the statement or answers the question.

Find the equation of the line in slope-intercept form. 1)

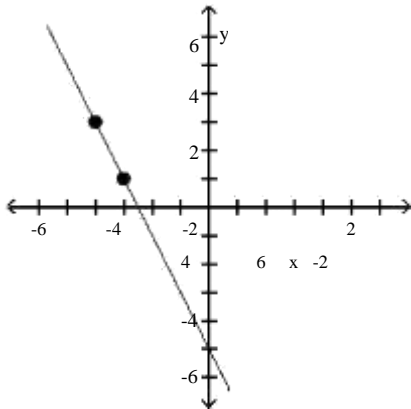

A) $y = -2x - 5$

$1x - 7$

C) $y = -2x + 2$

D) y

B) $y = -$

$\frac{2}{5}$

$= -2x + 5$



Find an equation for the line, in the indicated form, with the given properties.

2) Containing the points (4, 1) and (2, -4); slope-intercept form

A) $y = \frac{5}{2}x - 9$
 B) $y - 1 = \frac{5}{2}(x - 4)$

C) $y = mx - 9$

D) $y = -\frac{5}{2}x - 9$

D)

$y = -\frac{5}{2}x - 9$

2

3) Containing the points (1, -8) and (-4, 3); general form

A) $11x + 5y = -29$

B) $-11x + 5y = -29$

C) $-9x + 7y = 15$

D) $9x - 7y = 15$

4) Containing the points (8, 0) and (0, -12); general form

A) $12x - 8y = 96$

B) $12x + 8y = 96$

C) $\frac{3}{2}x - 12y = 96$

D) $3x + 8y = 96$

C) $y = -\frac{3}{2}x - 12$

5) Containing the points (6, 4) and (2, 9); general form

A) $5x + 4y = 46$

B) $-5x + 4y = 46$

C) $-2x + 7y = -67$

D) $2x - 7y = -67$

6) Containing the points (-2, 6) and (0, 9); general form

A) $3x - 2y = -18$

B) $-3x - 2y = -18$

C) $8x + 9y = -81$

D) $-8x - 9y = -81$

7) Containing the points (-8, 0) and (4, -5); general form

A) $-5x - 12y = 40$

B) $5x - 12y = 40$

C) $8x - 9y = -13$

D) $-8x + 9y = -13$

8) Containing the points (6, -5) and (-3, 3); general form

A) $8x + 9y = 3$

B) $-8x + 9y = 3$

C) $-11x + 6y = 15$

Solve.

D) $11x - 6y = 15$

9) The relationship between Celsius (°C) and Fahrenheit (°F) degrees of measuring temperature is linear.

Find an equation relating °C and °F if 10°C corresponds to 50°F and 30°C corresponds to 86°F. Use the equation to find the Celsius measure of 20° F.

A) $C = \frac{5}{9}F - \frac{160}{9}$; $- \frac{20}{9}$ °C

B) $C = \frac{5}{9}F + \frac{160}{9}$; $\frac{260}{9}$ °C

C) $C = \frac{9}{5}F - 80$; -44 °C

D) $C = \frac{9}{5}F - 10$; $\frac{10}{9}$ °C

E) $C = \frac{9}{5}F - 10$; $\frac{10}{9}$ °C

F) $C = \frac{9}{5}F - 10$; $\frac{10}{9}$ °C

G) $C = \frac{9}{5}F - 10$; $\frac{10}{9}$ °C

H) $C = \frac{9}{5}F - 10$; $\frac{10}{9}$ °C



- 10) A school has just purchased new computer equipment for \$19,000.00. The graph shows the depreciation of the equipment over 5 years. The point (0, 19,000) represents the purchase price and the point (5, 0) represents when the equipment will be replaced. Write a linear equation in slope-intercept form that relates the value of the equipment, y , to years after purchase x . Use the equation to predict the value of the equipment after 1 year.

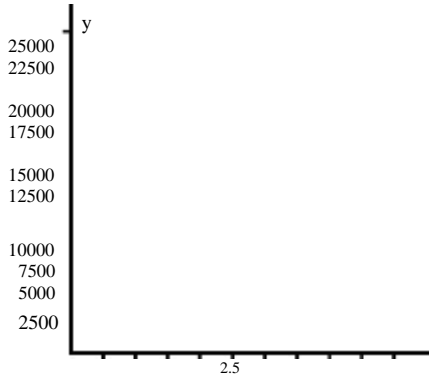

- A) $y = -3800x + 19,000$; value after 1 year is \$15,200.00;
 B) $y = 19,000x + 5$; value after 1 year is \$15,200.00
 C) $y = 3800x - 19,000$; value after 1 year is \$15,200.00
 D) $y = -19,000x + 19,000$; value after 1 year is \$0.00
- 11) The average value of a certain type of automobile was \$13,980 in 1995 and depreciated to \$4500 in 2000. Let y be the average value of the automobile in the year x , where $x = 0$ represents 1995. Write a linear equation that relates the average value of the automobile, y , to the year x .

- A) $y = -1896x + 13,980$
 B) $y = -1896x + 4500$
 C) $y = -1896x - 4980$
 D) $y = -\frac{1}{1896}x - 4500$

- 12) An investment is worth \$3765 in 1994. By 1997 it has grown to \$4338. Let y be the value of the investment in the year x , where $x = 0$ represents 1994. Write a linear equation that relates the value of the investment, y , to the year x .

- A) $y = 191x + 3765$
 B) $y = \frac{1}{191}x + 3765$
 C) $y = -191x + 4911$
 D) $y = -191x + 3765$

- 13) A faucet is used to add water to a large bottle that already contained some water. After it has been filling for 3 seconds, the gauge on the bottle indicates that it contains 11 ounces of water. After it has been filling for 11 seconds, the gauge indicates the bottle contains 27 ounces of water. Let y be the amount of water in the bottle x seconds after the faucet was turned on. Write a linear equation that relates the amount of water in the bottle, y , to the time x .

- A) $y = 2x + 5$
 B) $y = \frac{1}{2}x + \frac{19}{2}$
 C) $y = -2x + 17$
 D) $y = 2x + 16$

- 14) When making a telephone call using a calling card, a call lasting 5 minutes cost \$0.95. A call lasting 14 minutes cost \$1.85. Let y be the cost of making a call lasting x minutes using a calling card. Write a linear equation that relates the cost of a making a call, y , to the time x .

- A) $y = 0.1x + 0.45$
 B) $y = \frac{981}{20}x - 12.15$
 C) $y = -0.1x + 1.45$
 D) $y = 0.1x - 12.15$

15) A vendor has learned that, by pricing hot dogs at \$1.25, sales will reach 107 hot dogs per day. Raising the price to \$2.00 will cause the sales to fall to 68 hot dogs per day. Let y be the number of hot dogs the vendor sells at x dollars each. Write a linear equation that relates the number of hot dogs sold per day, y , to the price x .

- A) $y = -52x + 172$ $\frac{1}{x} + \frac{22251}{\quad}$ C) $y = 52x + 42$ D) $y =$
 B) $y = -$ $\frac{52}{208}$ $-52x - 172$

16) A vendor has learned that, by pricing caramel apples at \$1.50, sales will reach 112 caramel apples per day. Raising the price to \$2.25 will cause the sales to fall to 73 caramel apples per day. Let y be the number of caramel apples the vendor sells at x dollars each. Write a linear equation that relates the number of caramel apples sold per day to the price x .

- A) $y = -52x + 190$ $\frac{1}{x} + \frac{11645}{\quad}$ C) $y = 52x + 34$ D) $y =$
 B) $y = -$ $\frac{52}{104}$ $-52x - 190$

6 Write the Equation of a Line in Slope-Intercept Form

MULTIPLE CHOICE. Choose the one alternative that best completes the statement or answers the question.

Find the slope-intercept form of the equation of the line with the given properties. 1)

Slope = 5; containing the point (-2, -5)

- A) $y = 5x + 5$ B) $y = 5x - 5$ C) $y = -5x - 5$
 D) $y = -5x + 5$

2) Slope = 0; containing the point (-6, -3)

- A) $y = -3$ B) $y = -6$ C) $x = -3$
 D) $x = -6$

3) Slope = 2; y-intercept = -8

- A) $y = 2x - 8$ B) $y = 2x + 8$ C) $y = -8x - 2$
 D) $y = -8x + 2$

4) x-intercept = 3; y-intercept = 5

- A) $y = -\frac{5}{3}x + 5$ B) $y = -\frac{5}{3}x + 3$ C) $y = \frac{5}{3}x + 5$ D) $y = -\frac{5}{3}x + 3$
 3 5

Write the equation in slope-intercept form.

5) $11x + 2y = 17$

- A) $y = -\frac{11}{2}x + \frac{17}{2}$ B) $y = \frac{11}{2}x + \frac{17}{2}$ C) $y = 11x - 17$ D) $y = \frac{11}{2}x - \frac{17}{2}$
 $\frac{17}{2}$ $\frac{17}{2}$ $\frac{17}{2}$ $\frac{17}{2}$

6) $6x + 7y = 3$ $\frac{2}{2}$ $\frac{2}{2}$ $\frac{2}{2}$ $\frac{2}{2}$

- A) $y = -\frac{6}{7}x + \frac{3}{7}$ B) $y = 6x + 10$ C) $y = -\frac{10}{6}x + 3$ D) $y = \frac{7}{6}x + \frac{3}{6}$
 $\frac{3}{7}$ $\frac{3}{7}$ $\frac{3}{7}$ $\frac{3}{7}$

7) $3x - 5y = 9$

- A) $y = \frac{3}{5}x - \frac{9}{5}$ B) $y = \frac{3}{5}x + 9$ C) $y = \frac{5}{3}x + 9$ D) $y = 3x - 9$
 $\frac{9}{5}$ $\frac{9}{5}$ $\frac{9}{5}$ $\frac{9}{5}$

8) $x = 7y + 6$

- A) $y = \frac{1}{7}x - \frac{6}{7}$ B) $y = 7x - 6$ C) $y = \frac{1}{7}x - 6$

C) $y =$

D) $y = x -$



Solve.

9) A truck rental company rents a moving truck one day by charging \$31 plus \$0.09 per mile. Write a linear equation that relates the cost C , in dollars, of renting the truck to the number x of miles driven. What is the cost of renting the truck if the truck is driven 210 miles?

- A) $C = 0.09x + 31$; \$49.90
B) $C = 31x + 0.09$; \$6510.09
C) $C = 0.09x + 31$; \$32.89
D) $C = 0.09x - 31$; \$12.10

10) Each week a soft drink machine sells x cans of soda for \$0.75/soda. The cost to the owner of the soda machine for each soda is \$0.10. The weekly fixed cost for maintaining the soda machine is \$25/week. Write an equation that relates the weekly profit, P , in dollars to the number of cans sold each week. Then use the equation to find the weekly profit when 92 cans of soda are sold in a week.

- A) $P = 0.65x - 25$; \$34.80
B) $P = 0.65x + 25$; \$84.80
C) $P = 0.75x - 25$; \$44.00
D) $P = 0.75x + 25$; \$94.00

11) Each day the commuter train transports x passengers to or from the city at \$1.75/passenger. The daily fixed cost for running the train is \$1200. Write an equation that relates the daily profit, P , in dollars to the number of passengers each day. Then use the equation to find the daily profit when the train has 920 passengers in a day.

- A) $P = 1.75x - 1200$; \$410
B) $P = 1200 - 1.75x$; \$410
C) $P = 1.75x + 1200$; \$2810
D) $P = 1.75x$; \$1610

12) Each month a beauty salon gives x manicures for \$12.00/manicure. The cost to the owner of the beauty salon for each manicure is \$7.35. The monthly fixed cost to maintain a manicure station is \$120.00. Write an equation that relates the monthly profit, in dollars, to the number of manicures given each month. Then use the equation to find the monthly profit when 200 manicures are given in a month.

- A) $P = 4.65x - 120$; \$810
B) $P = 12x - 120$; \$2280
C) $P = 7.35x - 120$; \$1350
D) $P = 4.65x$; \$930

13) Each month a gas station sells x gallons of gas at \$1.92/gallon. The cost to the owner of the gas station for each gallon of gas is \$1.32. The monthly fixed cost for running the gas station is \$37,000. Write an equation that relates the monthly profit, in dollars, to the number of gallons of gasoline sold. Then use the equation to find the monthly profit when 75,000 gallons of gas are sold in a month.

- A) $P = 0.60x - 37,000$; \$8000
B) $P = 1.32x - 37,000$; \$62,000
C) $P = 1.92x - 37,000$; \$107,000
D) $P = 0.60x + 37,000$; \$82,000

7 Identify the Slope and y-Intercept of a Line from Its Equation

MULTIPLE CHOICE. Choose the one alternative that best completes the statement or answers the question.

Find the slope and y-intercept of the line.

1) $y = \frac{7}{4}x - 4$

A) slope = $\frac{7}{4}$; y-intercept = -4

B) slope = -7

C) slope = $\frac{4}{7}$; y-intercept = 4

D) slope = - $\frac{7}{4}$; y-intercept = 4

2) $x + y = -6$

A) slope = -1; y-intercept = -6

B) slope = 1;

y-intercept = -6 C) slope = 0; y-intercept = -6

D) slope = -1; y-intercept = 6

3) $5x + y = 8$

- A) slope = -5; y-intercept = 8
- B) slope = -
- C) slope = 5; y-intercept = 8
- D) slope =

- 1; y-intercept = 8
- 5
- 5; y-intercept = 1
- 8
- 8

4) $-6x + 7y = 10$

- A) slope = $\frac{6}{7}$; y-intercept = $\frac{10}{7}$
- C) slope = $\frac{7}{6}$; y-intercept = $\frac{10}{6}$

- B) slope = 6; y-intercept = 12
- D) slope = 7; y-intercept = -

5) $2x + 9y = 19$

- A) slope = -2; y-intercept = $\frac{19}{9}$
- C) slope = 2; y-intercept = 19
- D) slope =

- B) slope = 2; y-intercept =
- 2; y-intercept = - $\frac{19}{9}$
- 9

6) $7x - 6y = 5$

- A) slope = 7; y-intercept = - $\frac{5}{6}$
- C) slope = $\frac{6}{7}$; y-intercept = $\frac{5}{7}$

- B) slope = 7; y-intercept =
- D) slope = 7; y-intercept = 5

7) $12x - 3y = 36$

- A) slope = 4; y-intercept = -12
- y-intercept = 12
- C) slope = $\frac{1}{4}$; y-intercept = 3
- ~~12~~; y-intercept = 36

- B) slope = -4;
- D) slope =

8) $x + 11y = 1$

- A) slope = - $\frac{1}{11}$; y-intercept = $\frac{1}{11}$
- C) slope = $\frac{11}{11}$; y-intercept = $\frac{1}{11}$

- B) slope = 1; y-intercept = 1
- D) slope = -11; y-intercept = 11

9) $-x + 7y = 84$

- A) slope = $\frac{1}{7}$; y-intercept = 12
- ~~7~~ slope = -
- 7
- C) slope = -1; y-intercept = 84
- y-intercept = -84

- 1; y-intercept = 12
- D) slope = 7;

10) $y = -5$

- A) slope = 0; y-intercept = -5
- 5; y-intercept = 0
- C) slope = 1; y-intercept = -5
- D) slope = 0; no y-intercept

- B) slope =

11) $x = -1$

- A) slope undefined; no y-intercept
- y-intercept = -1

- B) slope = 0;

C) slope = -1; y-intercept = 0
y-intercept = -1

D) slope undefined;



12) $y = 4x$

A) slope = 4; y-intercept = 0

-4; y-intercept = 0

C) slope = $\frac{1}{4}$; y-intercept = 0
~~4~~; y-intercept = 4

B) slope =

D) slope =

8 Graph Lines Written in General Form Using Intercepts

MULTIPLE CHOICE. Choose the one alternative that best completes the statement or answers the question.

Find the general form of the equation for the line with the given properties.

1) Slope = $\frac{3}{5}$; y-intercept = 4

A) $3x - 5y = -4$

B) $3x + 5y = -4$

$3x + 4$

D) $y = \frac{3}{5}x - 4$

C) $y =$

2) Slope = $-\frac{3}{5}$; containing the point (5, 2)

A) $3x + 5y = 25$

B) $3x - 5y = 25$

C) $3x + 5y = -25$

D) $5x + 3y = -25$

3) Slope = $-\frac{5}{9}$; containing the point (0, 3)

A) $5x + 9y = 27$

B) $5x - 9y = 27$

C) $5x + 9y = -27$

D) $9x + 5y = -27$

4) Slope = $\frac{2}{9}$; containing (0, 2)

A) $-2x + 9y = 18$

B) $-2x - 9y = 18$

C) $-2x + 9y = -18$

D) $9x - 2y = -18$

Find the slope of the line and sketch its graph.

5) $3x + 4y = 25$

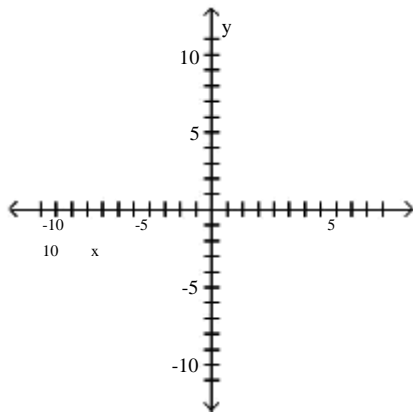

A) slope = $-\frac{3}{4}$

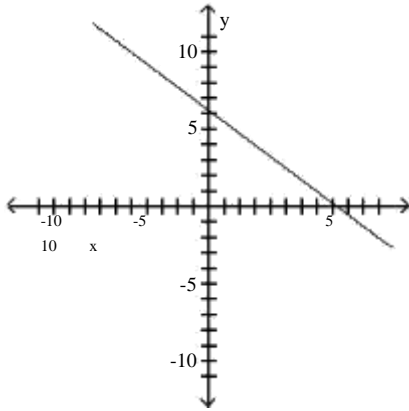

B) slope = $\frac{3}{4}$

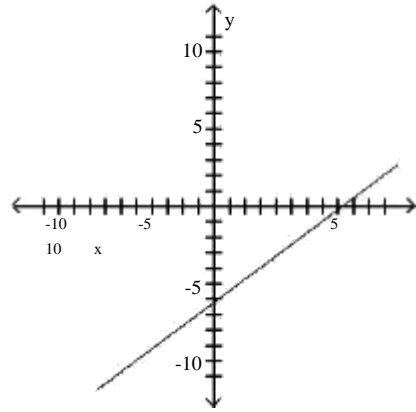

C) slope = $-\frac{4}{3}$

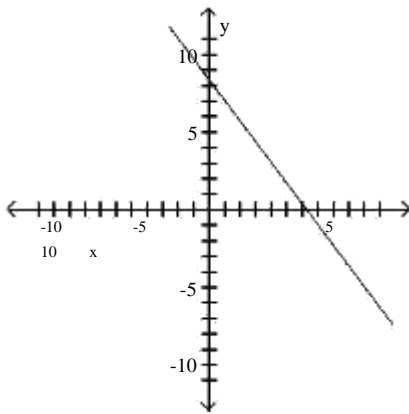

D) slope = $\frac{4}{3}$

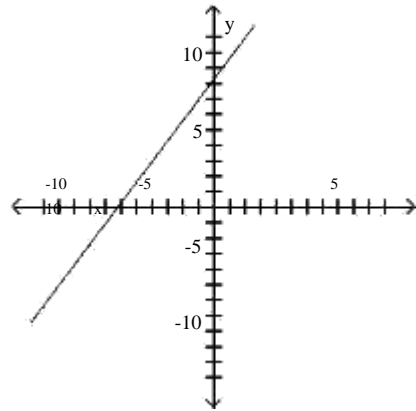

6) $4x - 5y = 2$

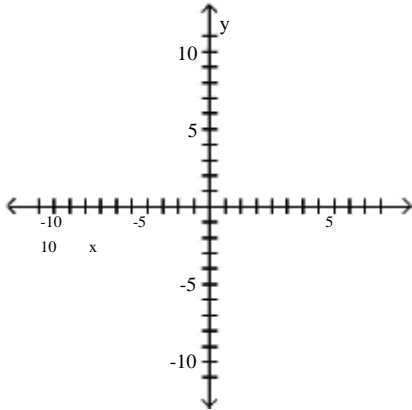

A) slope = $\frac{4}{5}$

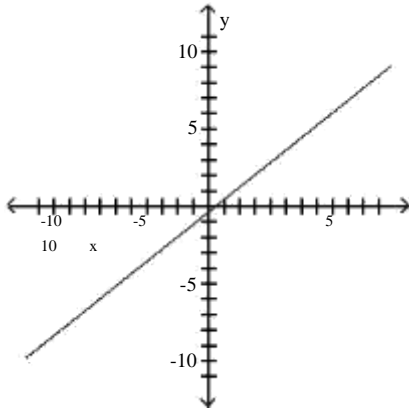

B) slope = $-\frac{4}{5}$

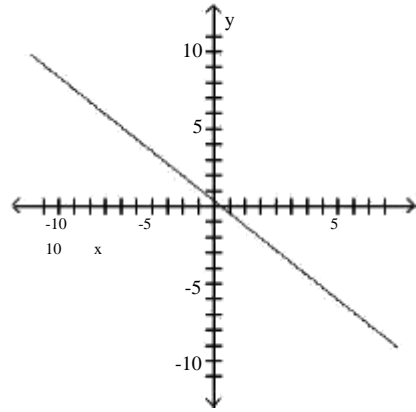

C) slope = $\frac{5}{4}$

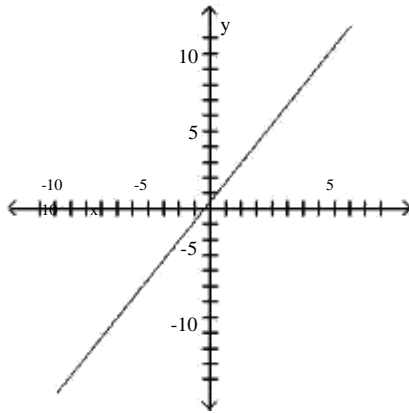

D) slope = $-\frac{5}{4}$

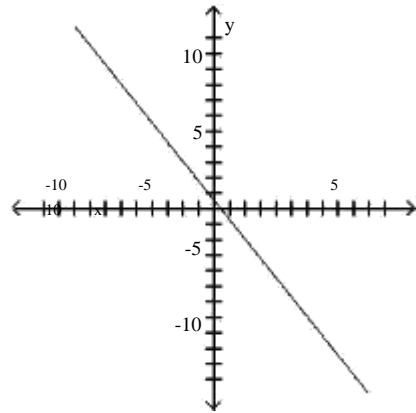

Solve the problem.

7) Find an equation in general form for the line graphed on a graphing utility.

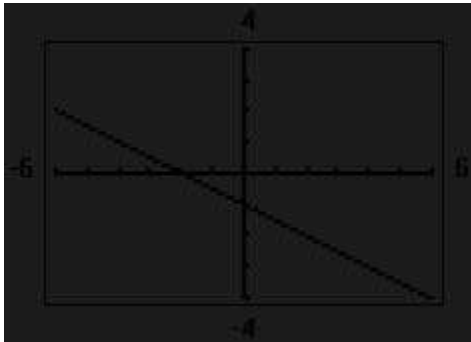

A) $x + 2y = -2$
 B) $y = -$

$\frac{1}{2}x - 1$
 B) $y = -2x - 1$

C) $2x + y = -1$

10 Find Equations of Perpendicular Lines

MULTIPLE CHOICE. Choose the one alternative that best completes the statement or answers the question.

Find an equation for the line with the given properties.

- 1) The solid line L contains the point (3, 2) and is perpendicular to the dotted line whose equation is $y = 2x$.
Give the equation of line L in slope-intercept form.

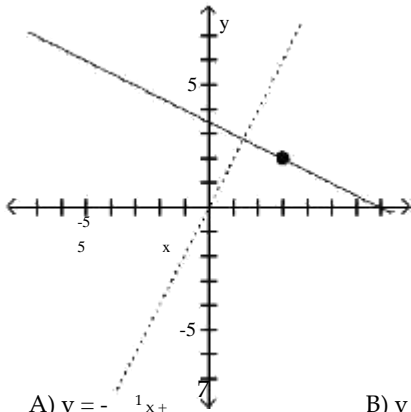

- A) $y = -\frac{1}{2}x + \frac{7}{2}$ B) $y - 2 = -\frac{1}{2}(x - 3)$ C) $y = \frac{1}{2}x + \frac{7}{2}$ D) $y - 2 = 2(x - 3)$

- 2) Perpendicular to the line $y = 2x + 1$; containing the point $(-4, -1)$

- A) $y = -\frac{1}{2}x - 3$ B) $y = \frac{1}{2}x - 3$ C) $y = -2x - 3$

- 3) Perpendicular to the line $y = \frac{1}{7}x + 8$; containing the point $(3, -2)$

- A) $y = -7x + 19$ B) $y = 7x - 19$ C) $y = -7x - 19$ D) $y = \frac{1}{7}x - \frac{19}{7}$

- 4) Perpendicular to the line $-2x - y = 6$; containing the point $(0, -3)$

- A) $y = \frac{1}{2}x - 3$ B) $y = \frac{1}{2}x + 6$ C) $y = -\frac{1}{2}x + 6$ D) $y = -\frac{1}{2}x - 32$

- 5) Perpendicular to the line $x - 7y = 6$; containing the point $(4, 4)$

- A) $y = -7x + 32$ B) $y = 7x - 32$ C) $y = -7x - 32$ D) $y = \frac{1}{7}x - \frac{32}{7}$

- 6) Perpendicular to the line $y = 8$; containing the point $(2, 3)$

- A) $x = 2$ B) $x = 3$ C) $y = 2$ D) $y = 3$

- 7) Perpendicular to the line $x = -4$; containing the point $(3, 8)$

- A) $y = 8$ B) $x = 8$ C) $y = 3$ D) $x = 3$

- 8) Perpendicular to the line $-9x - 7y = -82$; containing the point $(6, -4)$

- A) $7x - 9y = 78$ B) $7x + 9y = 78$ C) $-9x + 7 = -9$ D) $6x + 7y = -82$

- 9) Perpendicular to the line $-7x + 4y = -15$; containing the point $(5, 6)$

- A) $4x + 7y = 62$ B) $4x - 7y = 62$ C) $-7x - 4y = 62$ D) $4x - 7y = -15$

- 10) Perpendicular to the line $-2x - 3y = -6$; y -intercept = -4

- A) $-3x + 2y = -8$ B) $-2x - 3y = 12$ C) $-3x + 2y = 12$

$$D) -2x - 3y = 8$$



Decide whether the pair of lines is parallel, perpendicular, or neither.

11) $3x - 4y = -4$

$8x + 6y = -11$

A) parallel

B) perpendicular

C) neither

12) $3x - 4y = 16$

$8x + 6y = -4$

A) parallel

B) perpendicular

C) neither

13) $12x + 4y = 16$

$18x + 6y = 26$

A) parallel

B) perpendicular

C) neither

2.4 Circles

1 Write the Standard Form of the Equation of a Circle

MULTIPLE CHOICE. Choose the one alternative that best completes the statement or answers the question.

Write the standard form of the equation of the circle. 1)

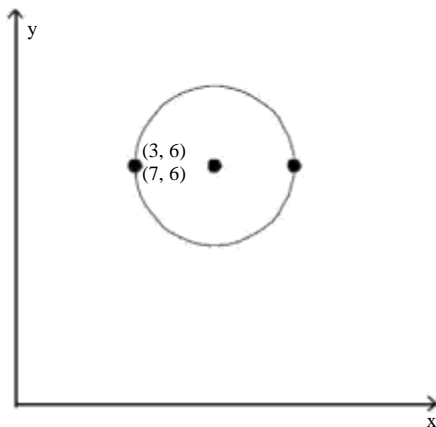

A) $(x - 5)^2 + (y - 6)^2 = 4$

B) $(x -$

$5)^2 + (y - 6)^2 = 2$ C) $(x + 5)^2 + (y + 6)^2 = 4$

D) $(x + 5)^2 + (y + 6)^2 = 2$

2)

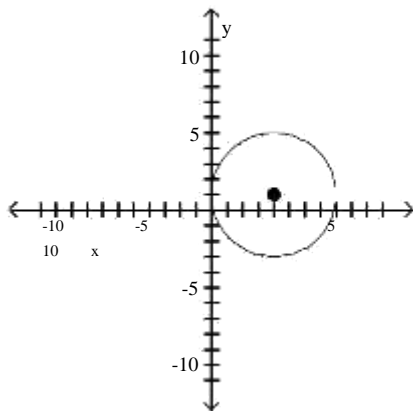

A) $(x - 4)^2 + (y - 1)^2 = 16$

B) $(x + 4)^2$

$+ (y + 1)^2 = 16$ C) $(x - 1)^2 + (y - 4)^2 = 16$

D) $(x + 1)^2 + (y + 4)^2 = 16$

Write the standard form of the equation of the circle with radius r and center (h, k) .

3) $r = 4$; $(h, k) = (0, 0)$

A) $x^2 + y^2 = 16$

B) $x^2 + y^2 = 4$

C) $(x - 4)^2 + (y - 4)^2 = 16$

D) $(x -$

4) $r = 4$; $(h, k) = (3, -5)$

A) $(x - 3)^2 + (y + 5)^2 = 16$

B) $(x +$

$3)^2 + (y - 5)^2 = 16$ C) $(x - 3)^2 + (y + 5)^2 = 4$

D) $(x + 3)^2 + (y - 5)^2 = 4$

5) $r = 6$; $(h, k) = (6, 0)$

A) $(x - 6)^2 + y^2 = 36$

B) $(x + 6)^2 + y^2 = 36$

C) $x^2 + (y - 6)^2 = 6$

D) $x^2 + (y +$

$6)^2 = 6$

6) $r = 6$; $(h, k) = (0, 10)$

A) $x^2 + (y - 10)^2 = 36$

B) $x^2 + (y + 10)^2 = 6$

C) $(x - 10)^2 + y^2 = 36$

D) $(x + 10)^2 + y^2 = 36$

7) $r = \sqrt{19}$; $(h, k) = (8, -8)$

A) $(x - 8)^2 + (y + 8)^2 = 19$

B) $(x + 8)^2 + (y - 8)^2 = 19$

C) $(x + 8)^2 + (y - 8)^2 = 361$

D) $(x - 8)^2 + (y + 8)^2 = 361$

$\sqrt{}$

8) $r = 7$; $(h, k) = (0, -9)$

A) $x^2 + (y + 9)^2 = 7$

B) $x^2 + (y - 9)^2 = 7$

C) $(x + 9)^2 + y^2 = 49$

D) $(x - 9)^2 + y^2 = 49$

Solve the problem.

9) Find the equation of a circle in standard form where $C(6, -2)$ and $D(-4, 4)$ are endpoints of a diameter.

A) $(x - 1)^2 + (y - 1)^2 = 34$

B) $(x +$

$1)^2 + (y + 1)^2 = 34$ C) $(x - 1)^2 + (y - 1)^2 = 136$

D) $(x + 1)^2 + (y + 1)^2 = 136$

10) Find the equation of a circle in standard form with center at the point $(-3, 2)$ and tangent to the line $y = 4$. A)

$(x + 3)^2 + (y - 2)^2 = 4$

B) $(x + 3)^2 + (y - 2)^2 = 16$

C) $(x - 3)^2 + (y + 2)^2 = 4$

D) $(x - 3)^2 + (y + 2)^2 = 16$

11) Find the equation of a circle in standard form that is tangent to the line $x = -3$ at $(-3, 5)$ and also tangent to the line $x = 9$.

A) $(x - 3)^2 + (y - 5)^2 = 36$

B) $(x +$

$3)^2 + (y - 5)^2 = 36$ C) $(x - 3)^2 + (y + 5)^2 = 36$

D) $(x + 3)^2 + (y + 5)^2 = 36$

Find the center (h, k) and radius r of the circle with the given equation. 12)

$x^2 + y^2 = 16$

A) $(h, k) = (0, 0)$; $r = 4$

B) $(h, k) = (0, 0)$; $r = 16$ C) $(h, k) = (4, 4)$; $r = 4$

D) $(h, k) = (4, 4)$; $r = 16$

13) $(x - 4)^2 + (y - 2)^2 = 64$

A) $(h, k) = (4, 2)$; $r = 8$

B) $(h, k) = (4, 2)$; $r = 64$ C) $(h, k) = (2, 4)$; $r = 8$

D) $(h, k) = (2, 4)$; $r = 64$

14) $(x - 3)^2 + y^2 = 100$

A) $(h, k) = (3, 0)$; $r = 10$

B) $(h, k) = (0, 3)$; $r = 10$ C) $(h, k) = (0, 3)$; $r = 100$

D) $(h, k) = (3, 0)$; $r = 100$

15) $x^2 + (y + 2)^2 = 4$

A) $(h, k) = (0, -2); r = 2$

~~B) $(h, k) = (-2, 0); r = 2$~~

D) $(h, k) = (0, -2); r = 4$

16) $2(x + 6)^2 + 2(y + 3)^2 = 18$

A) $(h, k) = (-6, -3); r = 3$

B)

$(h, k) = (-6, -3); r = 6$ C) $(h, k) = (6, 3); r = 3$

D) $(h, k) = (6, 3); r = 6$

Solve the problem.

17) Find the standard form of the equation of the circle. Assume that the center has integer coordinates and the radius is an integer.

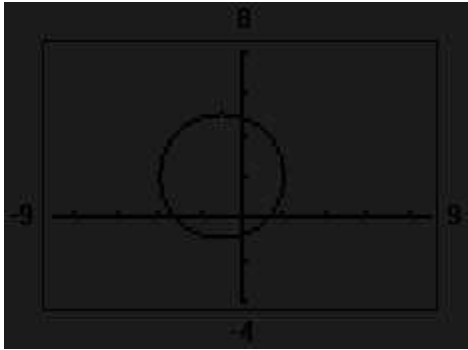

A) $(x + 1)^2 + (y - 2)^2 = 9$

B) $(x -$

$1)^2 + (y + 2)^2 = 9$ C) $x^2 + y^2 + 2x - 4y - 4 = 0$

D) $x^2 + y^2 - 2x + 4y - 4 = 0$



2 Graph a Circle

MULTIPLE CHOICE. Choose the one alternative that best completes the statement or answers the question.

Graph the circle with radius r and center (h, k) .

1) $r = 3$; $(h, k) = (0, 0)$

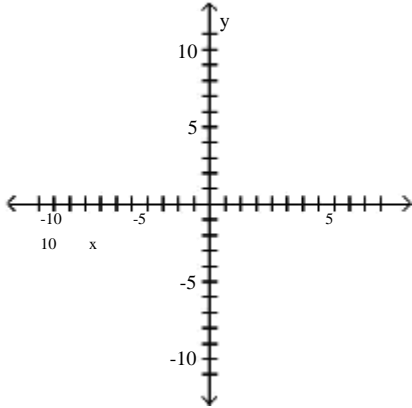

- A)
- B)

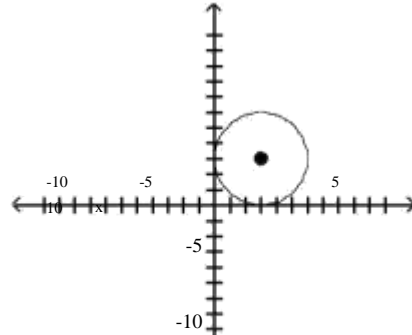
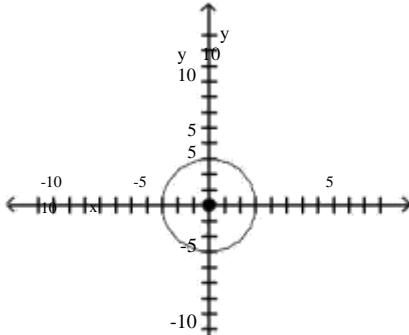

- C)
- D)

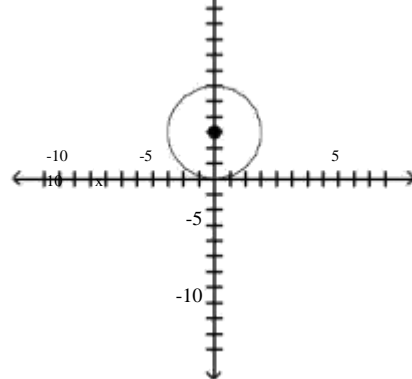
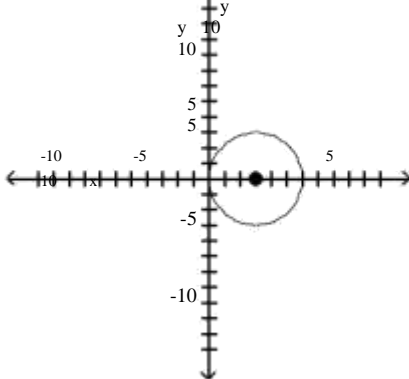

2) $r = 4$; $(h, k) = (0, 2)$

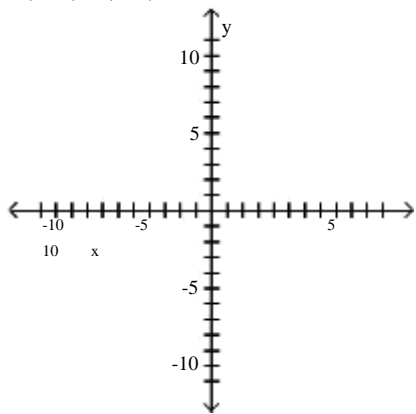

A)

B)

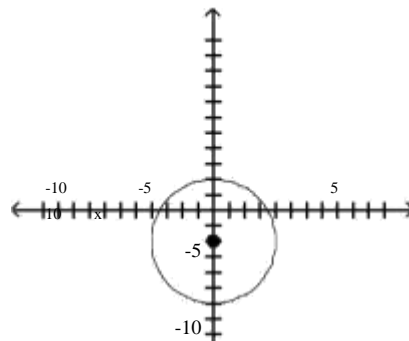
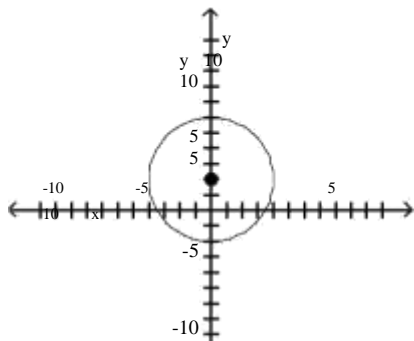

C)

D)

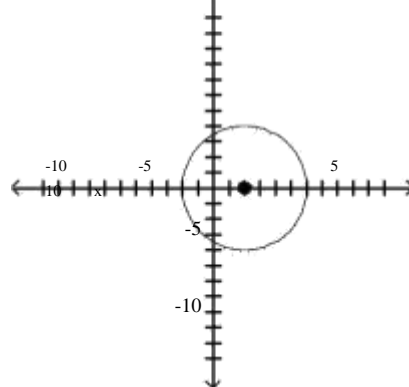
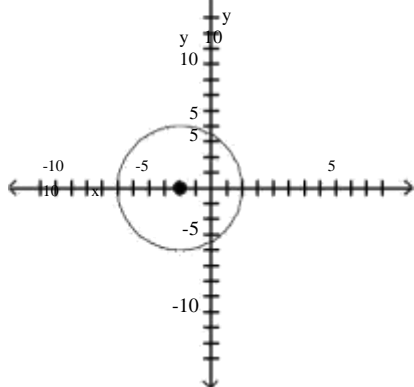

3) $r = 5$; $(h, k) = (1, 0)$

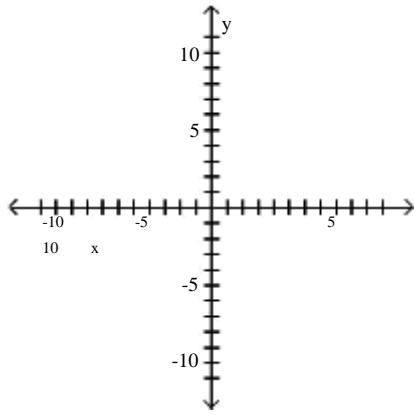

A)

B)

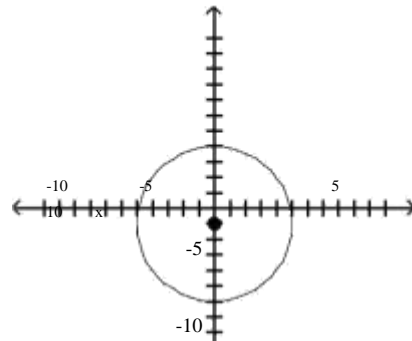
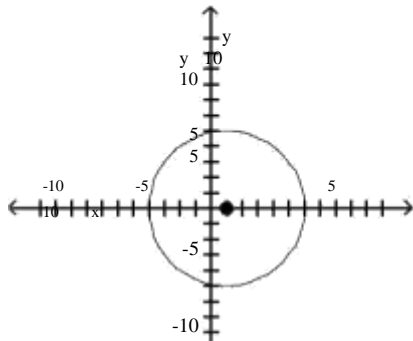

C)

D)

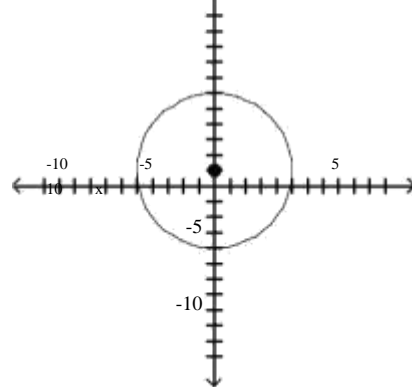
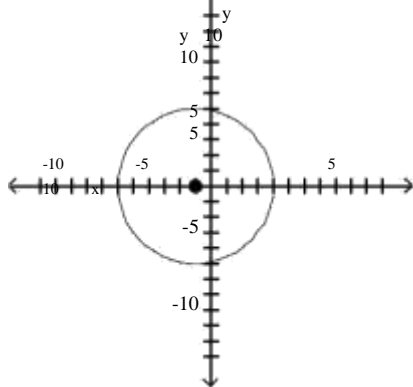

4) $r = 3$; $(h, k) = (-1, 3)$

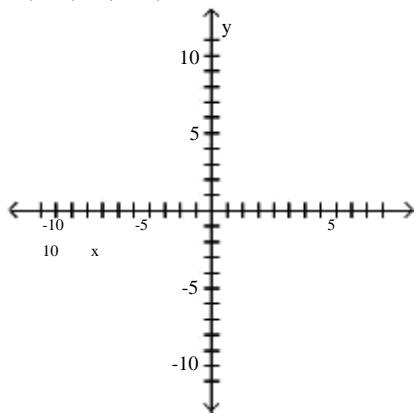

A)

B)

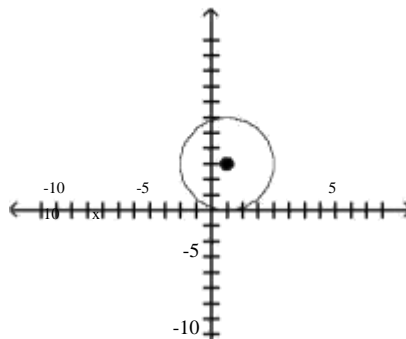
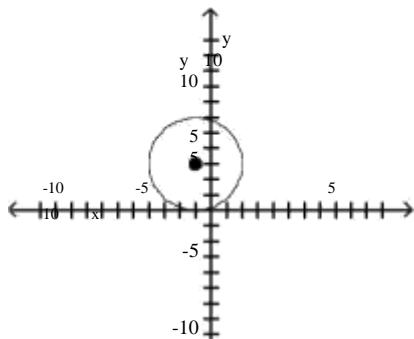

C)

D)

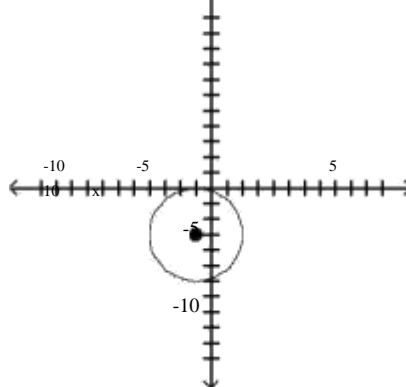
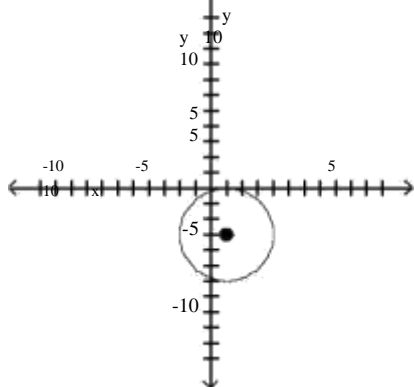

Graph the equation.

5) $x^2 + y^2 = 4$

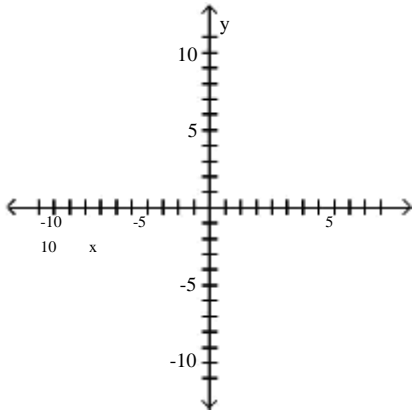

A)

B)

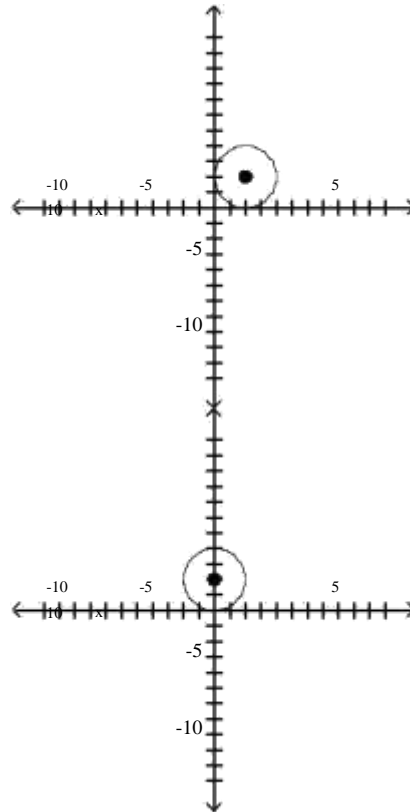
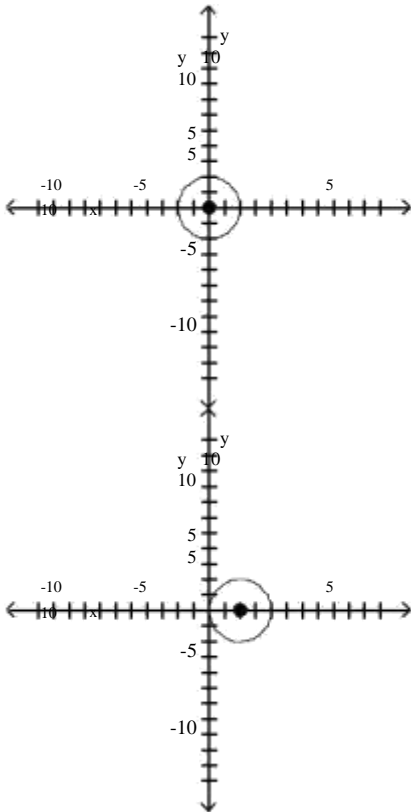

C)

D)

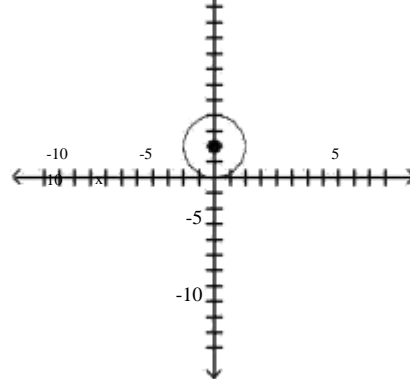
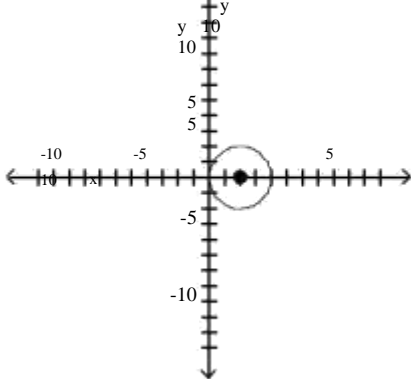

6) $(x - 4)^2 + (y + 3)^2 = 4$

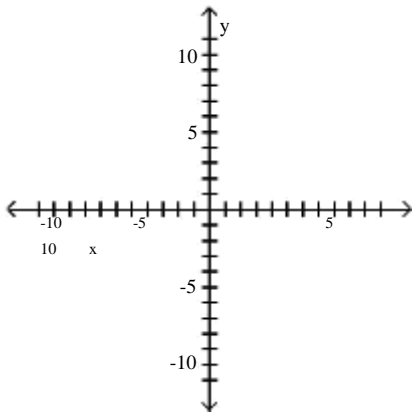

A)

B)

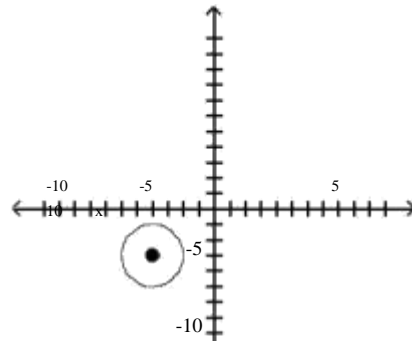
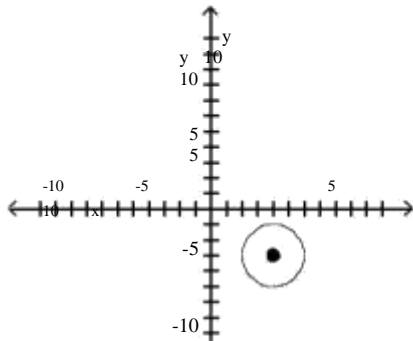

C)

D)

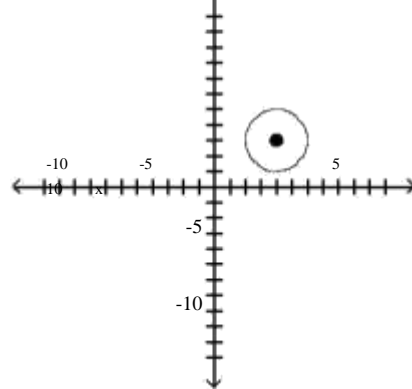
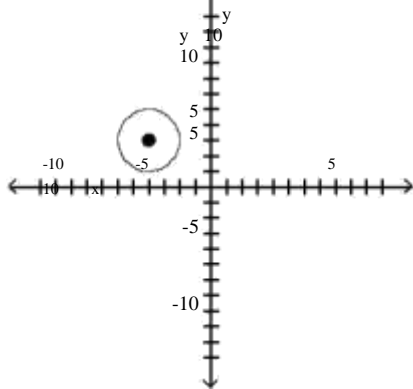

7) $x^2 + (y - 1)^2 = 25$

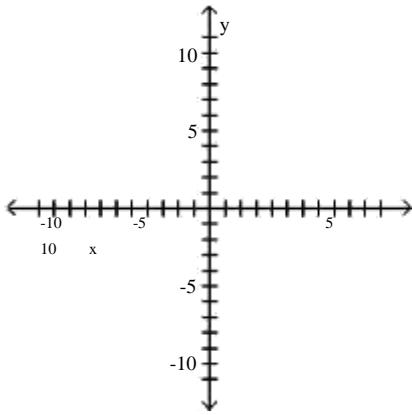

A)

B)

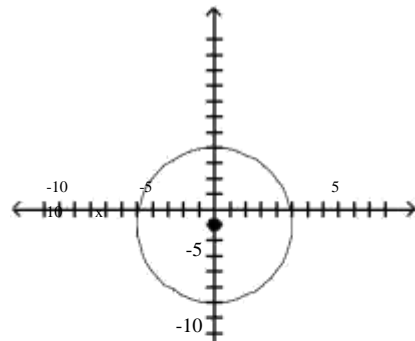
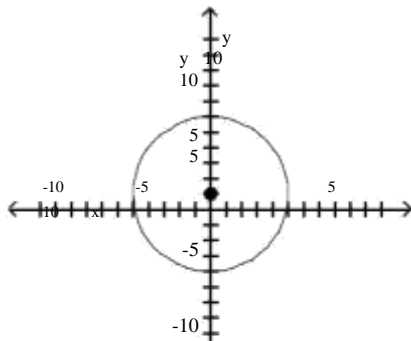

C)

D)

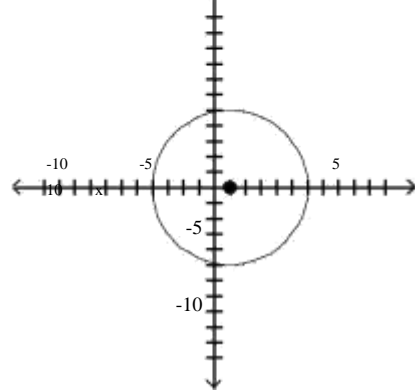
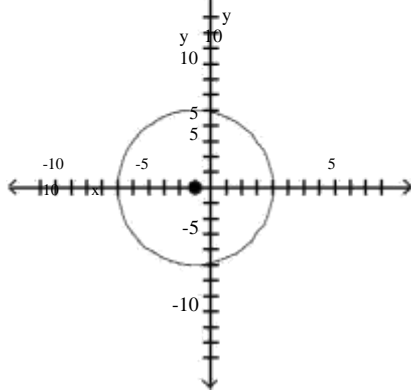

8) $(x - 4)^2 + y^2 = 4$

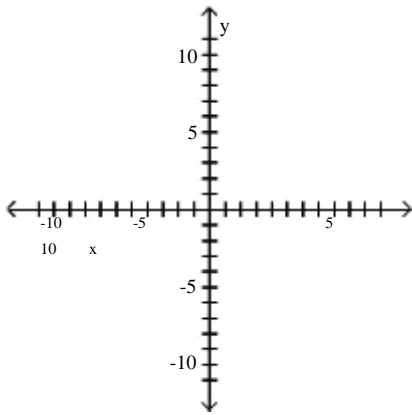

A)
B)

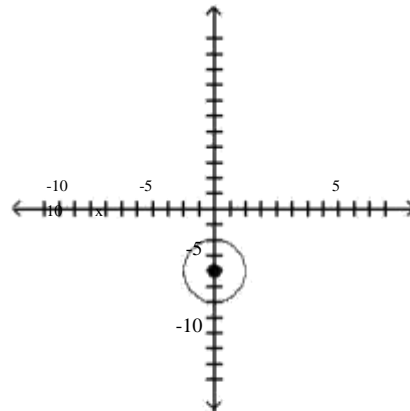
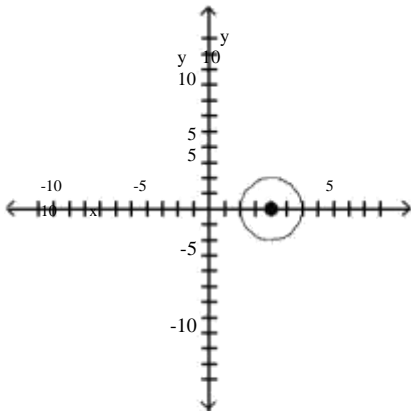

C)
D)

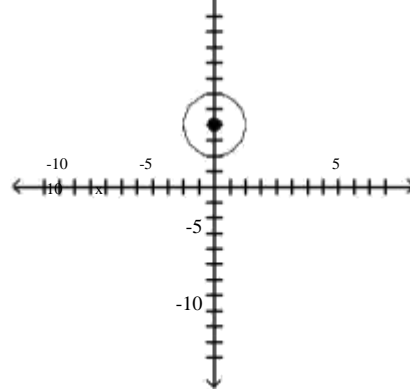
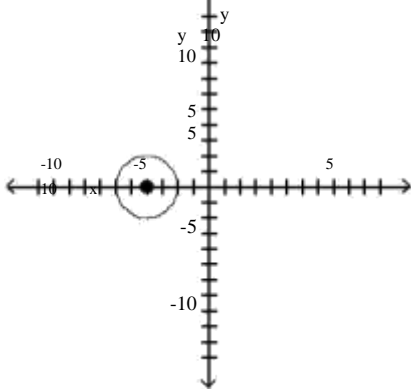

3 Work with the General Form of the Equation of a Circle

MULTIPLE CHOICE. Choose the one alternative that best completes the statement or answers the question.

Find the center (h, k) and radius r of the circle. Graph the circle. 1)

$$x^2 + y^2 - 2x - 12y + 28 = 0$$

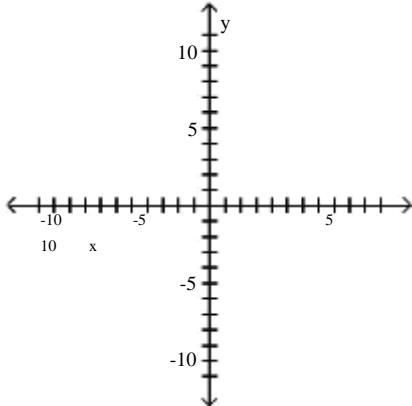

A) $(h, k) = (1, 6); r = 3$

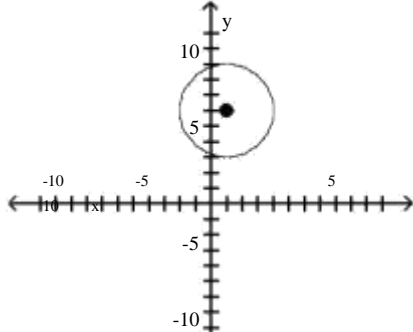

C) $(h, k) = (1, -6); r = 3$

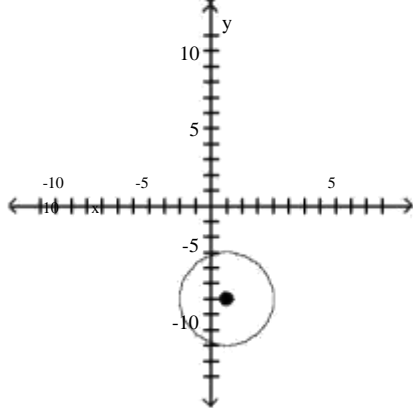

B) $(h, k) = (-1, -6); r = 3$

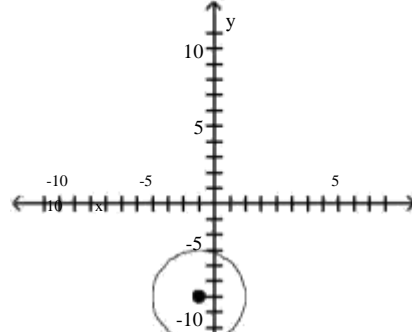

D) $(h, k) = (-1, 6); r = 3$

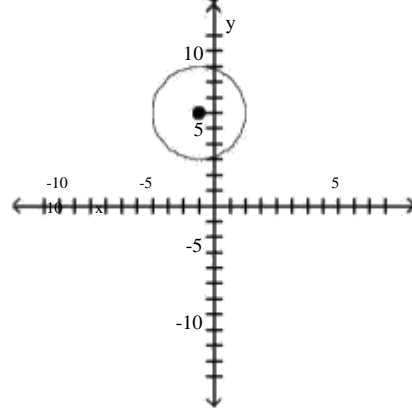

2) $x^2 + y^2 + 6x + 12y + 36 = 0$

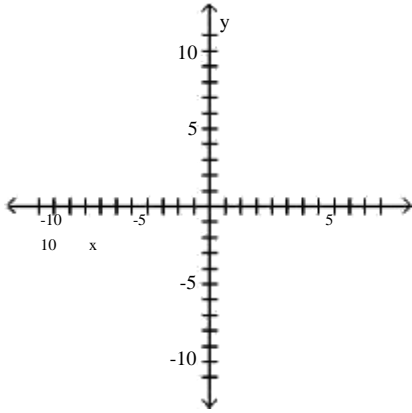

A) $(h, k) = (-3, -6); r = 3$

B) $(h, k) = (3, -6); r = 3$

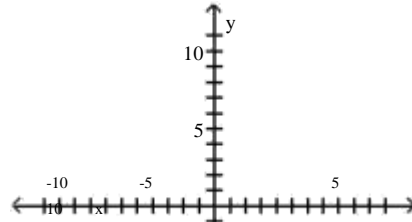
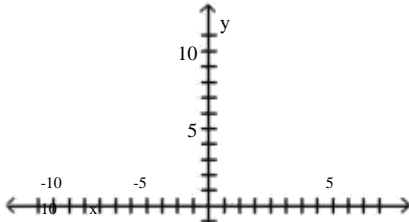

C) $(h, k) = (3, 6); r = 3$

D) $(h, k) = (-3, 6); r = 3$

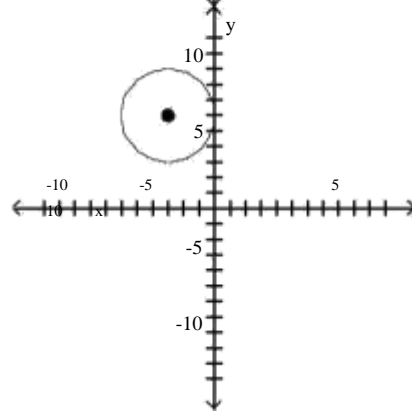
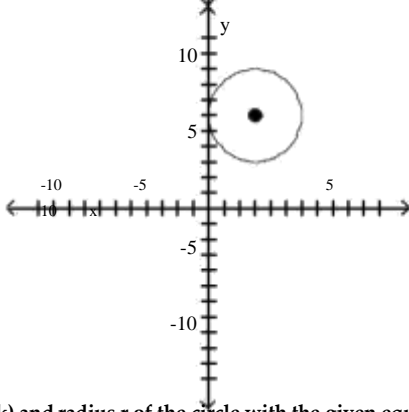

Find the center (h, k) and radius r of the circle with the given equation. 3)

$x^2 + 18x + 81 + (y - 6)^2 = 64$

A) $(h, k) = (-9, 6); r = 8$

B) $(h, k) = (6, -9); r = 8$ C) $(h, k) = (9, -6); r = 64$

D) $(h, k) = (-6, 9); r = 64$

4) $x^2 - 14x + 49 + y^2 - 6y + 9 = 64$

A) $(h, k) = (7, 3); r = 8$

B) $(h, k) = (3, 7); r = 8$ C) $(h, k) = (-7, -3); r = 64$

D) $(h, k) = (-3, -7); r = 64$

5) $x^2 + y^2 + 12x - 18y + 117 = 36$

A) $(h, k) = (-6, 9); r = 6$

B) $(h, k) = (9, -6); r = 6$ C) $(h, k) = (6, -9); r = 36$

D) $(h, k) = (-9, 6); r = 36$



6) $x^2 + y^2 - 10x + 8y = 40$

A) $(h, k) = (5, -4); r = 9$

B) $(h, k) = (5, 4); r = 9$

D)

$(h, k) = (4, -5); r = 81$ 7) $4x^2 + 4y^2 - 12x + 16y - 5 = 0$

A) $(h, k) = (-3, -2); r = \sqrt{30}$

B) $(h, k) = (-3, 2); r = \sqrt{30}$

C) $(h, k) = (-3, -2); r = \frac{3\sqrt{30}}{5}$

D) $(h, k) = (-3, 2); r = \frac{3\sqrt{30}}{5}$

Find the general form of the equation of the circle.

8) Center at the point $(-4, -3)$; containing the point $(-3, 3)$

A) $x^2 + y^2 + 8x + 6y - 12 = 0$

B) $x^2 + y^2 + 6x$

+ $8y - 17 = 0$ C) $x^2 + y^2 - 6x + 6y - 12 = 0$

D) $x^2 + y^2 + 6x - 6y - 17 = 0$

9) Center at the point $(2, -3)$; containing the point $(5, -3)$

A) $x^2 + y^2 - 4x + 6y + 4 = 0$

B) $x^2 + y^2 +$

$4x - 6y + 4 = 0$ C) $x^2 + y^2 - 4x + 6y + 22 = 0$

D) $x^2 + y^2 + 4x - 6y + 22 = 0$

10) Center at the point $(7, 9)$; tangent to x-axis

A) $x^2 + y^2 - 14x - 18y + 49 = 0$

B) $x^2 + y^2 - 14x -$

$18y + 81 = 0$ C) $x^2 + y^2 + 14x + 18y + 49 = 0$

D)

$x^2 + y^2 - 14x - 18y + 211 = 0$

Solve the problem.

11) If a circle of radius 5 is made to roll along the x-axis, what is the equation for the path of the center of the circle?

A) $y = 5$

B) $y = 0$

C) $y = 10$

D) $x = 5$

12) Earth is represented on a map of the solar system so that its surface is a circle with the equation

$x^2 + y^2 + 10x + 2y - 4070 = 0$. A weather satellite circles 0.8 units above the Earth with the center of its circular orbit at the center of the Earth. Find the general form of the equation for the orbit of the satellite on this map.

A) $x^2 + y^2 + 10x + 2y - 4173.04 = 0$

B) $x^2 + y^2 + 10x + 2y -$

$37.36 = 0$ C) $x^2 + y^2 - 10x - 2y - 4173.04 = 0$

D) $x^2 + y^2 +$

$10x + 2y + 25.36 = 0$

13) Find an equation of the line containing the centers of the two circles x^2

+ $y^2 - 8x - 2y + 16 = 0$ and

$x^2 + y^2 + 2x - 8y + 13 = 0$

A) $-3x - 5y + 17 = 0$

B) $5x - 3y + 17 = 0$

C) $-3x + 5y + 17 = 0$

D)

$3x - 5y + 17 = 0$

14) A wildlife researcher is monitoring a black bear that has a radio telemetry collar with a transmitting range of 15 miles. The researcher is in a research station with her receiver and tracking the bear's movements. If we put the origin of a coordinate system at the research station, what is the equation of all possible locations of the bear where the transmitter would be at its maximum range?

A) $x^2 + y^2 = 225$

B) $x^2 + y^2 = 30$

C) $x^2 + y^2 = 15$

D) $x^2 - y^2 = 15$

15) If a satellite is placed in a circular orbit of 450 kilometers above the Earth, what is the equation of the path of the satellite if the origin is placed at the center of the Earth (the diameter of the Earth is approximately 12,740 kilometers)?

- A) $x^2 + y^2 = 46,512,400$ B) $x^2 + y^2 = 202,500$ C) $x^2 + y^2 = 40,576,900$ D) $x^2 + y^2 = 173,976,100$

16) A power outage affected all homes and businesses within a 10 mi radius of the power station. If the power station is located 11 mi north of the center of town, find an equation of the circle consisting of the furthest points from the station affected by the power outage.

- A) $x^2 + (y - 11)^2 = 100$ B) $x^2 + (y + 11)^2 = 100$ C) $x^2 + (y - 11)^2 = 10$ D) $x^2 + y^2 = 100$

17) A power outage affected all homes and businesses within a 3 mi radius of the power station. If the power station is located 4 mi west and 4 mi north of the center of town, find an equation of the circle consisting of the furthest points from the station affected by the power outage.

- A) $(x + 4)^2 + (y - 4)^2 = 9$ B) $(x - 4)^2 + (y - 4)^2 = 9$

18) A Ferris wheel has a diameter of 280 feet and the bottom of the Ferris wheel is 9 feet above the ground. Find the equation of the wheel if the origin is placed on the ground directly below the center of the wheel, as illustrated.

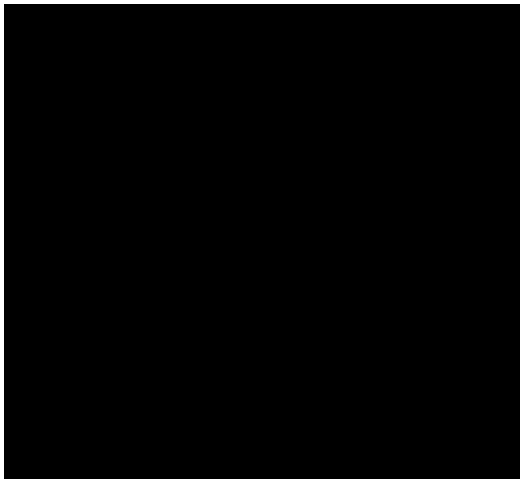

- A) $x^2 + (y - 149)^2 = 19,600$ B) $x^2 + (y - 140)^2 = 19,600$ C) $x^2 + (y - 140)^2 = 78,400$ D) $x^2 + y^2 = 19,600$

2.5 Variation

1 Construct a Model Using Direct Variation

MULTIPLE CHOICE. Choose the one alternative that best completes the statement or answers the question.

Write a general formula to describe the variation.

1) v varies directly with t ; $v = 10$ when $t = 4$

- A) $v = \frac{5}{2}t$ B) $v = \frac{2}{5}t$ C) $v = \frac{10}{4}t$ D) $v = \frac{4}{10}t$



2) A varies directly with t^2 ; A = 12 when $t = 2$

A) $A = 3t^2$

B) $A = 6t^2$

C) $A =$

$\frac{3}{t^2}$

D) $A = \frac{6}{t^2}$

3) z varies directly with the sum of the squares of x and y; z = 10 when x = 6 and y = 8

A) $z = \frac{1}{10}(x^2 + y^2)$

B) $z^2 = x^2 + y^2$

C) z

$\frac{1}{z}(x^2 + y^2)$

D)

$\frac{1}{(x^2 + y^2)}$

If y varies directly as x, write a general formula to describe the variation. 4)

y = 6 when x = 30

A) $y = \frac{1}{5}x$

B) $y = 5x$

C) $y = x +$

$\frac{1}{x}$

5) y = 18 when x = 4

A) $y = \frac{9}{2}x$

$\frac{2}{x}$

C) $y = x + 14$

D) $y = 2x$

6) y = 5 when x = $\frac{1}{7}$

A) $y = 35x$

$\frac{1}{x}$

$\frac{34}{5}$

D) $y = \frac{1}{35}x$

B) $y =$

C) $y = x +$

$\frac{5}{7}$

7) y = 1.6 when x = 0.8

A) $y = 2x$

B) $y = 0.8x$

C) $y = x + 0.8$

D) $y = 0.5x$

8) y = 0.4 when x = 1.6

A) $y = 0.25x$

B) $y = 0.4x$

C) $y = x - 1.2$

D) $y = 4x$

Write a general formula to describe the variation.

9) The volume V of a right circular cone varies directly with the square of its base radius r and its height h.

The constant of proportionality is $\frac{1}{3}\pi$.

A) $V = \frac{1}{3}\pi r^2 h$

B) $V = \frac{1}{3}\pi r h$

C) $V = \frac{1}{3}\pi r^2 h$

D) $V = \frac{1}{3}\pi r^2 h^2$

10) The surface area S of a right circular cone varies directly as the radius r times the square root of the sum of the squares of the base radius r and the height h. The constant of proportionality is p.

A) $S = \pi r \sqrt{r^2 + h^2}$

B) $S = \pi r^2 h^2$

C) $S = p \sqrt{r^2 + h^2}$

D) $S = \pi r^2 h$

Solve the problem.

11) In simplified form, the period of vibration P for a pendulum varies directly as the square root of its length L.

If P is 2 sec. when L is 16 in., what is the period when the length is 4 in.?

A) 1 sec

B) 2 sec

C) 4 sec

D) 8 sec

12) The amount of water used to take a shower is directly proportional to the amount of time that the shower is in use. A shower lasting 22 minutes requires 8.8 gallons of water. Find the amount of water used in a shower lasting 4 minutes.

A) 1.6 gal

B) 48.4 gal

C) 10 gal

D) 2.2 gal

- 7) $y = \frac{1}{5}$ when $x = 25$
- A) $y = 5$ B) $y = \frac{1}{x}$ C) $y = x$ D) $y = \frac{1}{5x}$
- 8) $y = 0.2$ when $x = 0.5$
- A) $y = \frac{0.1}{x}$ B) $y = 0.4x$ C) $y = 10x$ D) $y = \frac{10}{x}$

Solve the problem.

- 9) x varies inversely as v , and $x = 72$ when $v = 4$. Find x when $v = 32$.
- A) $x = 9$ B) $x = 16$ C) $x = 36$
 D) $x = 8$
- 10) x varies inversely as y^2 , and $x = 4$ when $y = 15$. Find x when $y = 5$.
- A) $x = 36$ B) $x = 48$ C) $x = 100$
 D) $x = 3$
- 11) When the temperature stays the same, the volume of a gas is inversely proportional to the pressure of the gas. If a balloon is filled with 180 cubic inches of a gas at a pressure of 14 pounds per square inch, find the new pressure of the gas if the volume is decreased to 36 cubic inches.
- A) 70 psi B) $\frac{18}{7}$ psi C) 56 psi
 D) 65 psi
- 12) The amount of time it takes a swimmer to swim a race is inversely proportional to the average speed of the swimmer. A swimmer finishes a race in 30 seconds with an average speed of 5 feet per second. Find the average speed of the swimmer if it takes 50 seconds to finish the race.
- A) 3 ft/sec B) 4 ft/sec C) 5 ft/sec
 D) 2 ft/sec
- 13) If the force acting on an object stays the same, then the acceleration of the object is inversely proportional to its mass. If an object with a mass of 35 kilograms accelerates at a rate of 3 meters per second per second (m/sec^2) by a force, find the rate of acceleration of an object with a mass of 7 kilograms that is pulled by the same force.
- A) 15 m/sec^2 B) 3 m/sec^2 C) 12 m/sec^2 D) 10 m/sec^2
- 14) If the voltage, V , in an electric circuit is held constant, the current, I , is inversely proportional to the resistance, R . If the current is 240 milliamperes (mA) when the resistance is 2 ohms, find the current when the resistance is 12 ohms.
- A) 40 mA B) 1440 mA C) 1434 mA
 D) 80 mA
- 15) While traveling at a constant speed in a car, the centrifugal acceleration passengers feel while the car is turning is inversely proportional to the radius of the turn. If the passengers feel an acceleration of 12 feet per second per second (ft/sec^2) when the radius of the turn is 70 feet, find the acceleration the passengers feel when the radius of the turn is 280 feet.
- A) 3 ft/sec^2 B) 4 ft/sec^2 C) 5 ft/sec^2 D) 6 ft/sec^2



3 Construct a Model Using Joint Variation or Combined Variation

MULTIPLE CHOICE. Choose the one alternative that best completes the statement or answers the question.

Write a general formula to describe the variation.

- 1) The square of G varies directly with the cube of x and inversely with the square of y; $G = 2$ when $x = 4$ and $y = 3$

A) $G^2 = \frac{9}{16} \frac{x^3}{y^2}$

B) $G^2 = \frac{3}{2} \frac{x^3}{y^2}$

C) $G^2 = \frac{256}{9} \frac{y^3}{x^2}$

D) $G^2 = \frac{1}{144} (x^3 + y^2)$

- 2) R varies directly with g and inversely with the square of h; $R = 3$ when $g = 3$ and $h = 5$. $\frac{g}{h^2}$

A) $R = \frac{25}{h^2}$

B) $R = 5 \frac{g}{h^2}$

C) $R = 5 \frac{h^2}{g}$

D) $R = 25gh^2$

- 3) z varies jointly as the cube root of x and the square of y; $z = 75$ when $x = 125$ and $y = 3$.

A) $z = \frac{5}{3} \sqrt[3]{xy^2}$

B) $z = \frac{3}{135} \sqrt[3]{xy^2}$

C) $z = \frac{3}{135} \sqrt[3]{x} y^2$

D) $z = \frac{1}{35} \sqrt[3]{xy^2}$

- 4) The centrifugal force F of an object speeding around a circular course varies directly as the product of the object's mass m and the square of its velocity v and inversely as the radius of the turn r.

A) $F = \frac{kmv^2}{r}$

B) $F = \frac{kmv}{r}$

C) $F = \frac{km^2v}{r}$

D) $F = \frac{kmr}{v^2}$

- 5) The safety load λ of a beam with a rectangular cross section that is supported at each end varies directly as the product of the width W and the square of the depth D and inversely as the length L of the beam between the supports.

A) $\lambda = \frac{kWD^2}{L}$

B) $\lambda = \frac{kWD}{L}$

C) $\lambda = \frac{k(W+D^2)}{L}$

D) $\lambda = \frac{kL}{WD^2}$

- 6) The illumination I produced on a surface by a source of light varies directly as the candlepower c of the source and inversely as the square of the distance d between the source and the surface.

A) $I = \frac{kc}{d^2}$

B) $I = \frac{kc^2}{d^2}$

C) $I = kcd^2$

D) $I = \frac{kd^2}{c}$

Solve the problem.

- 7) The volume V of a given mass of gas varies directly as the temperature T and inversely as the pressure P.

A measuring device is calibrated to give $V = 319.2 \text{ in}^3$ when $T = 570^\circ$ and $P = 25 \text{ lb/in}^2$. What is the volume on this device when the temperature is 160° and the pressure is 20 lb/in^2 ?

A) $V = 112 \text{ in}^3$

B) $V = 8 \text{ in}^3$

C) $V = 132 \text{ in}^3$

D) $V = 92 \text{ in}^3$

- 8) The time in hours it takes a satellite to complete an orbit around the earth varies directly as the radius of the

orbit (from the center of the earth) and inversely as the orbital velocity. If a satellite completes an orbit 840 miles above the earth in 9 hours at a velocity of 25,000 mph, how long would it take a satellite to complete an orbit if it is at 1600 miles above the earth at a velocity of 24,000 mph? (Use 3960 miles as the radius of the earth.)

A) 10.86 hr
D) 108.59 hr

B) 17.86 hr

C) 3.13 hr



Ch. 2 Graphs

Answer Key

2.1 The Distance and Midpoint Formulas

1 Rectangular

Coordinates

- 1) A
- 2) B
- 3) C
- 4) D
- 5) A
- 6) A
- 7) A
- 8) A
- 9) A
- 10) A
- 11) A
- 12) A
- 13) A
- 14) A
- 15) A
- 16) A
- 17) A
- 18) A

2 Use the Distance Formula

- 1) A
- 2) A
- 3) A
- 4) A
- 5) A
- 6) A
- 7) A
- 8) A
- 9) A
- 10) A
- 11) A
- 12) A
- 13) A
- 14) A
- 15) B
- 16) B
- 17) A
- 18) A
- 19) A
- 20) A
- 21) A
- 22) A
- 23) A

3 Use the Midpoint Formula

- 1) A
- 2) A
- 3) A
- 4) A
- 5) A



- 6) A
- 7) A
- 8) A
- 9) A
- 10) A
- 11) A

2.2 Graphs of Equations in Two Variables; Intercepts; Symmetry

1 Graph Equations by Plotting Points

- 1) A
- 2) A
- 3) A
- 4) A
- 5) A
- 6) A
- 7) A
- 8) A
- 9) A
- 10) A

2 Find Intercepts from a Graph

- 1) A
- 2) A
- 3) A
- 4) A
- 5) A
- 6) A
- 7) A
- 8) A

3 Find Intercepts from an Equation

- 1) A
- 2) A
- 3) A
- 4) A
- 5) A
- 6) A
- 7) A
- 8) A
- 9) A
- 10) A
- 11) A
- 12) A
- 13) A

4 Test an Equation for Symmetry with Respect to the x-Axis, the y-Axis, and the Origin

- 1) A
- 2) A
- 3) A
- 4) A
- 5) A
- 6) A
- 7) A
- 8) A
- 9) A
- 10) A



- 11) A
- 12) A
- 13) A
- 14) E
- 15) A
- 16) A
- 17) A
- 18) D
- 19) D
- 20) E
- 21) A
- 22) A
- 23) A
- 24) E
- 25) A
- 26) E
- 27) A
- 28) A

5 Know How to Graph Key Equations

- 1) A
- 2) A
- 3) A
- 4) A

2.3 Lines

1 Calculate and Interpret the Slope of a Line

- 1) A
- 2) A
- 3) A
- 4) A
- 5) A
- 6) A
- 7) A
- 8) A
- 9) D
- 10) A

2 Graph Lines Given a Point and the Slope

- 1) A
- 2) A
- 3) A
- 4) A
- 5) A
- 6) A
- 7) A
- 8) A
- 9) A

3 Find the Equation of a Vertical Line

- 1) A
- 2) A
- 3) A
- 4) A

4 Use the Point-Slope Form of a Line; Identify Horizontal Lines

- 1) A



- 2) A
- 3) A
- 4) A
- 5) A

5 Find the Equation of a Line Given Two Points

- 1) A
- 2) A
- 3) A
- 4) A
- 5) A
- 6) A
- 7) A
- 8) A
- 9) A
- 10) A
- 11) A
- 12) A
- 13) A
- 14) A
- 15) A
- 16) A

6 Write the Equation of a Line in Slope-Intercept Form

- 1) A
- 2) A
- 3) A
- 4) A
- 5) A
- 6) A
- 7) A
- 8) A
- 9) A
- 10) A
- 11) A
- 12) A
- 13) A

7 Identify the Slope and y -Intercept of a Line from Its Equation

- 1) A
- 2) A
- 3) A
- 4) A
- 5) A
- 6) A
- 7) A
- 8) A
- 9) A
- 10) A
- 11) A
- 12) A

8 Graph Lines Written in General Form Using Intercepts

- 1) A
- 2) A
- 3) A
- 4) A



- 5) A
- 6) A
- 7) A

9 Find Equations of Parallel Lines

- 1) A
- 2) A
- 3) A
- 4) A
- 5) A
- 6) A
- 7) A
- 8) A

10 Find Equations of Perpendicular Lines

- 1) A
- 2) A
- 3) A
- 4) A
- 5) A
- 6) A
- 7) A
- 8) A
- 9) A
- 10) A
- 11) B
- 12) B
- 13) A

2.4 Circles

1 Write the Standard Form of the Equation of a Circle

- 1) A
- 2) A
- 3) A
- 4) A
- 5) A
- 6) A
- 7) A
- 8) A
- 9) A
- 10) A
- 11) A
- 12) A
- 13) A
- 14) A
- 15) A
- 16) A
- 17) A

2 Graph a Circle

- 1) A
- 2) A
- 3) A
- 4) A
- 5) A
- 6) A

- 7) A
- 8) A

3 Work with the General Form of the Equation of a Circle

- 1) A
- 2) A
- 3) A
- 4) A
- 5) A
- 6) A
- 7) A
- 8) A
- 9) A
- 10) A
- 11) A
- 12) A
- 13) A
- 14) A
- 15) A
- 16) A
- 17) A
- 18) A

2.5 Variation

1 Construct a Model Using Direct Variation

- 1) A
- 2) A
- 3) A
- 4) A
- 5) A
- 6) A
- 7) A
- 8) A
- 9) A
- 10) A
- 11) A
- 12) A
- 13) A
- 14) A
- 15) A

2 Construct a Model Using Inverse Variation

- 1) A
- 2) A
- 3) A
- 4) A
- 5) A
- 6) A
- 7) A

- 8) A
- 9) A
- 10) A
- 11) A
- 12) A
- 13) A

14) A

15) A

3 Construct a Model Using Joint Variation or Combined Variation

1) A

2) A

3) A

4) A

5) A

6) A

7) A

8) A

9) A

10) A

11) A

12) A

13) A

14) A

15) A