

Test Bank for College Algebra 4th Edition by Robert F. Blitzer

ISBN 0132191415 9780132191418

Fullink download

Test Bank:

<https://testbankpack.com/p/test-bank-for-college-algebra-4th-edition-by-robert-blitzer-isbn-0132191415-9780132191418/>

Solution Manual:

<https://testbankpack.com/p/solution-manual-for-college-algebra-4th-edition-by-blitzer-isbn-0132191415-9780132191418/>

Ch. 1 Equations and Inequalities

1.1 Graphs and Graphing Utilities

1 Plot Points in the Rectangular Coordinate System

MULTIPLE CHOICE. Choose the one alternative that best completes the statement or answers the question.

Plot the given point in a rectangular coordinate system.

1) (4, 1)

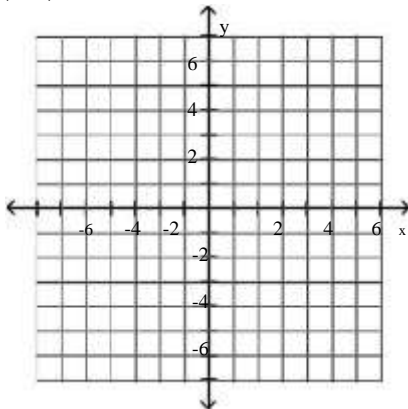

A)

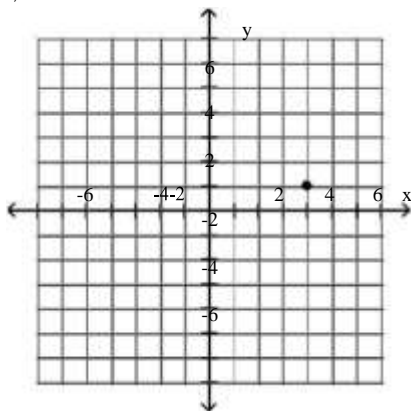

C)

y
6
4

B)

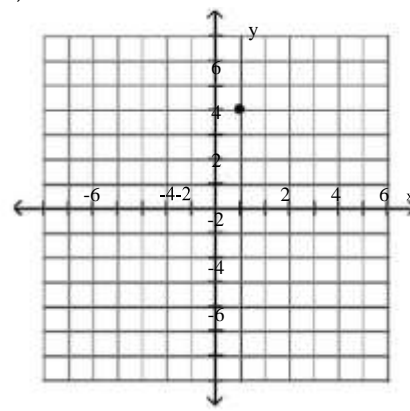

D)

y
6
4

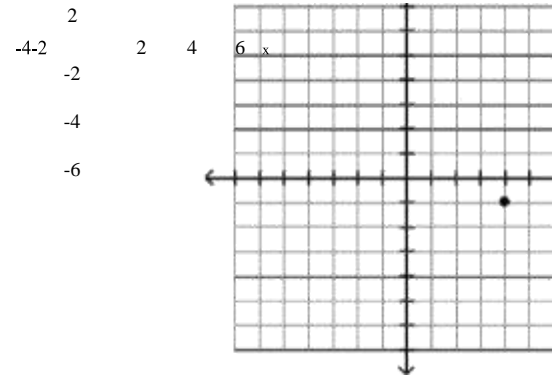
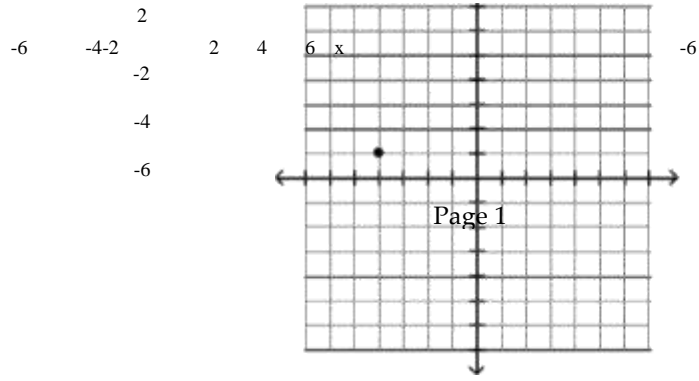

2) $(-6, 3)$

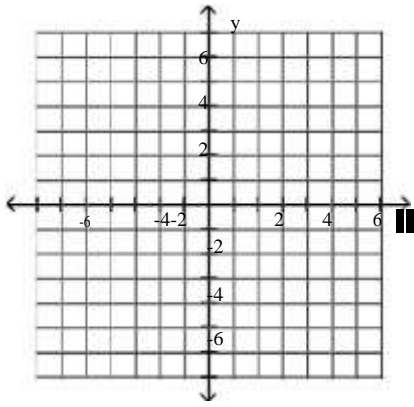

A)

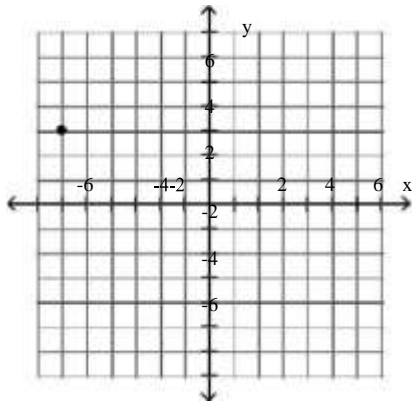

C)

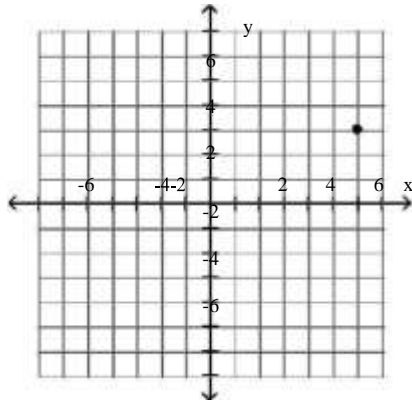

B)

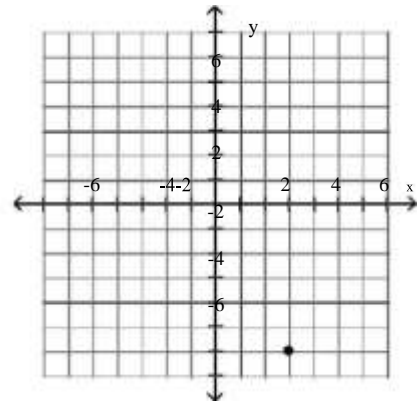

D)

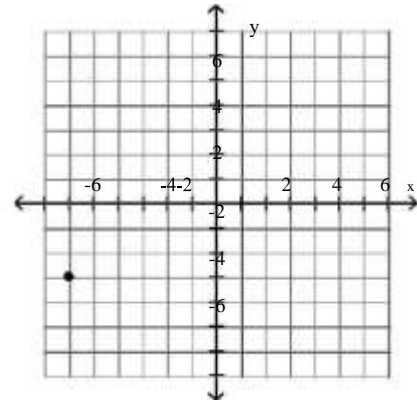

3) (1, -4)

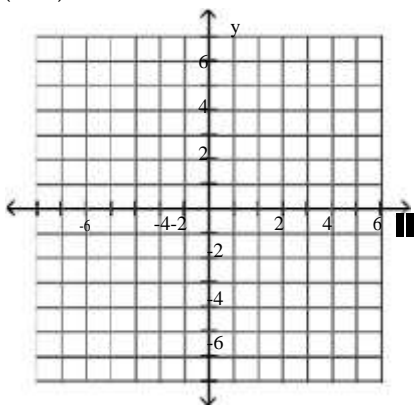

A)

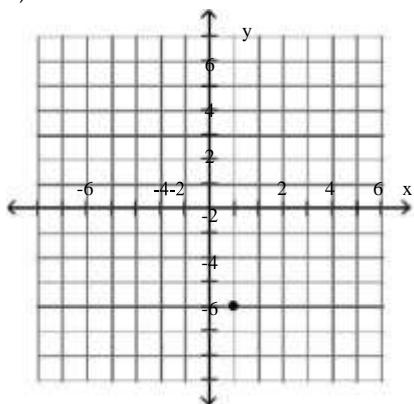

C)

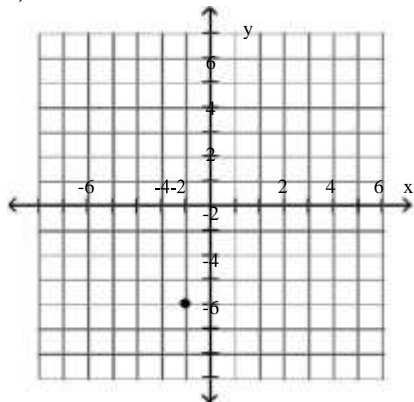

B)

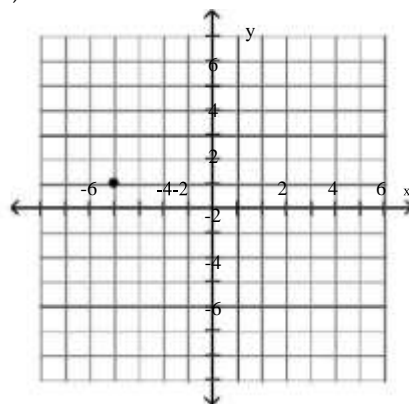

D)

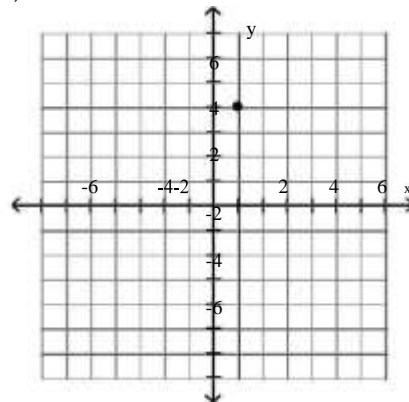

4) $(-1, -4)$

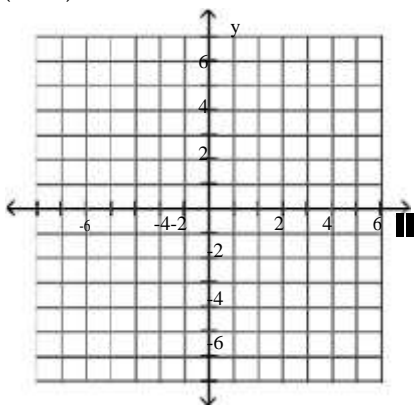

A)

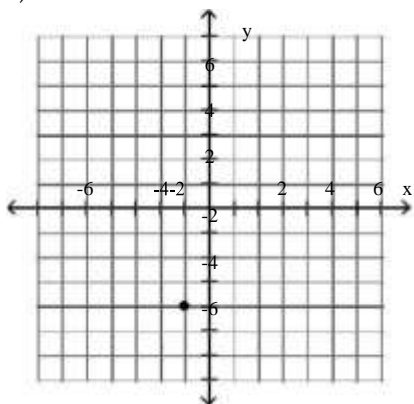

C)

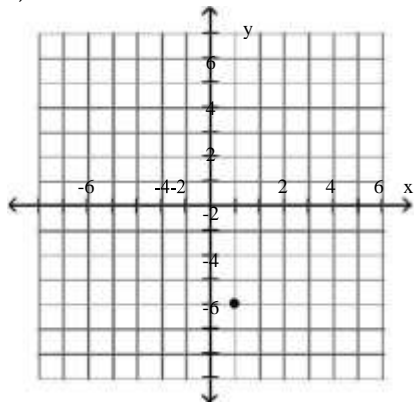

B)

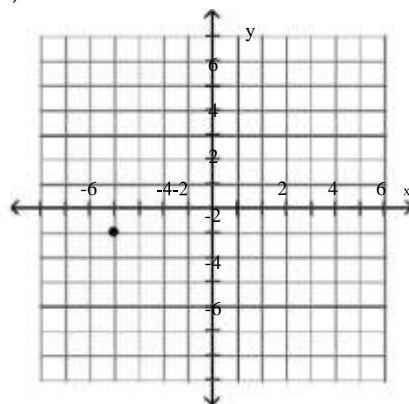

D)

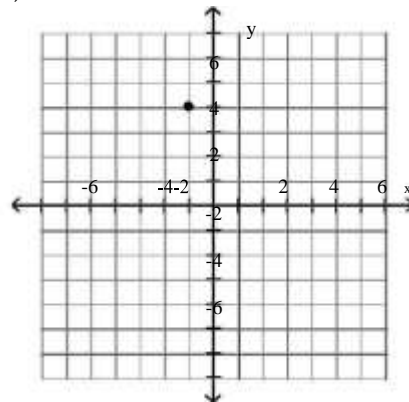

5) (0, -4)

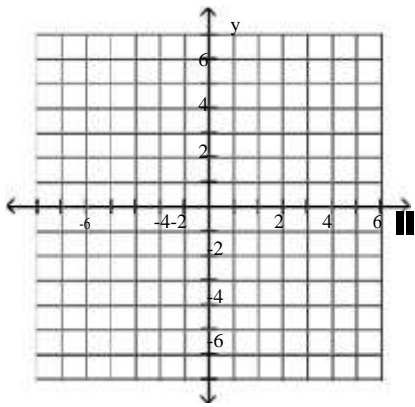

A)

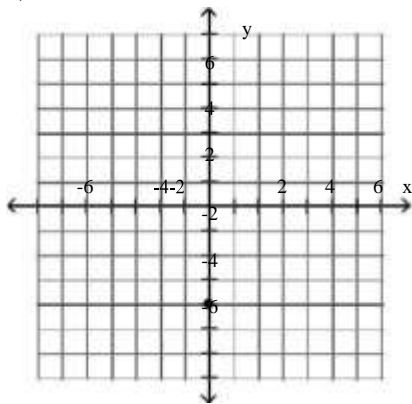

C)

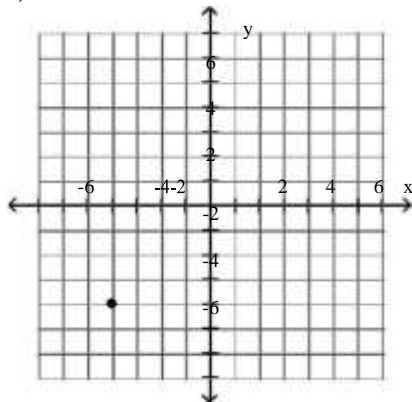

B)

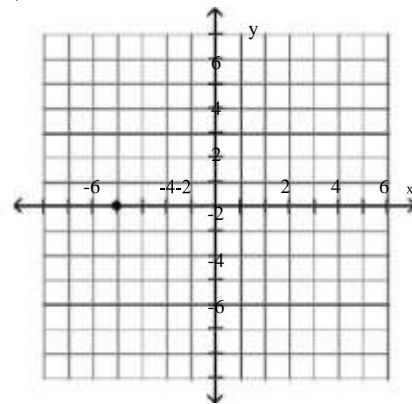

D)

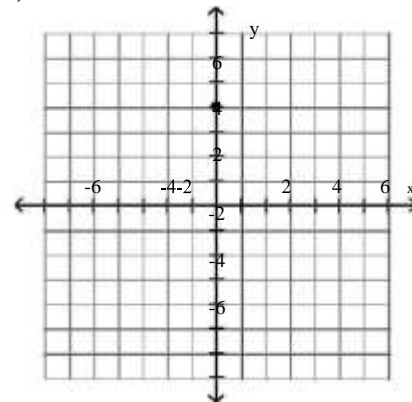

6) $(-4, 0)$

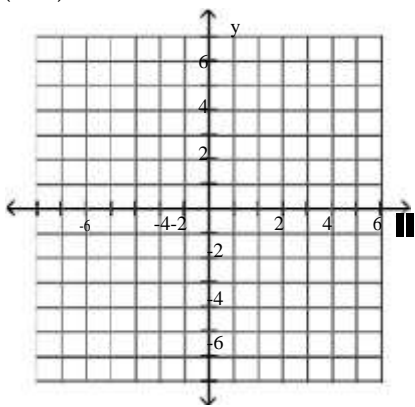

A)

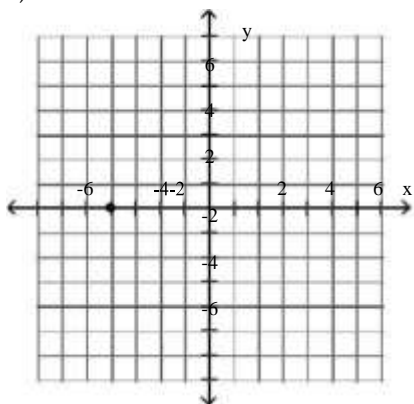

C)

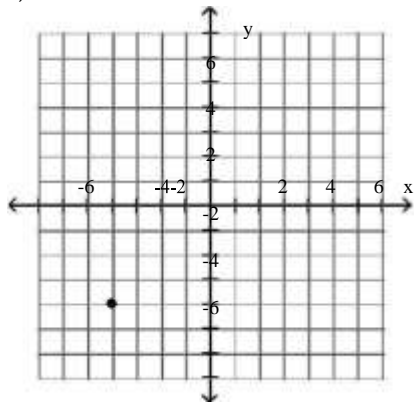

B)

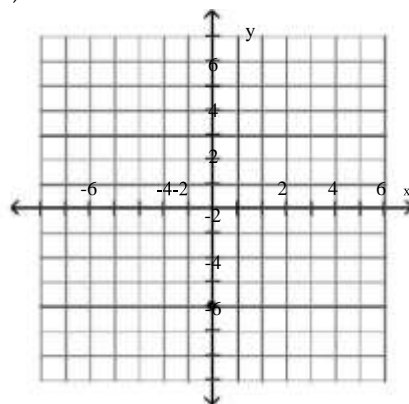

D)

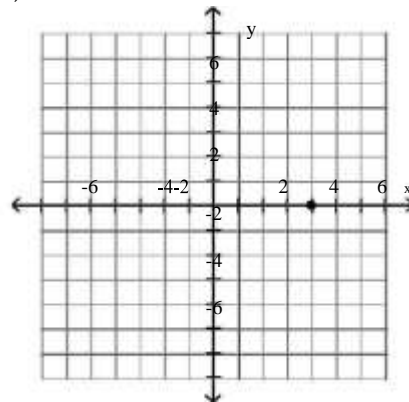

$$7) \left(\begin{array}{c} 9 \\ -2, -2 \end{array} \right)$$

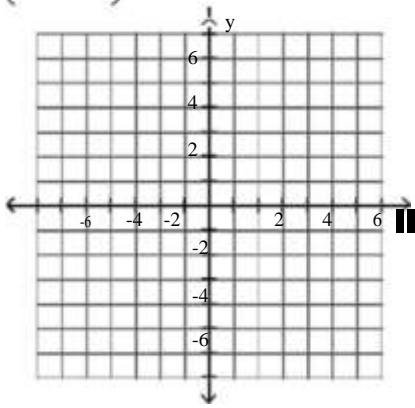

A)

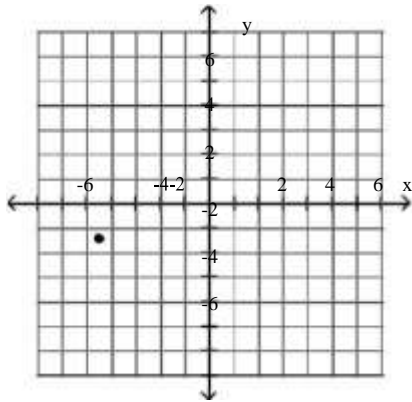

C)

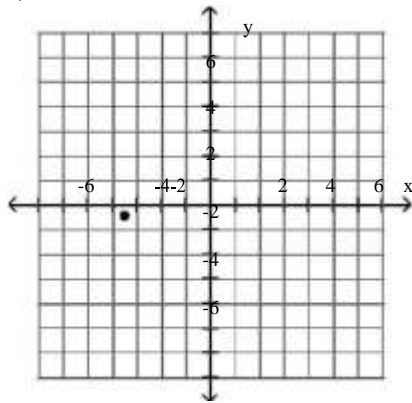

B)

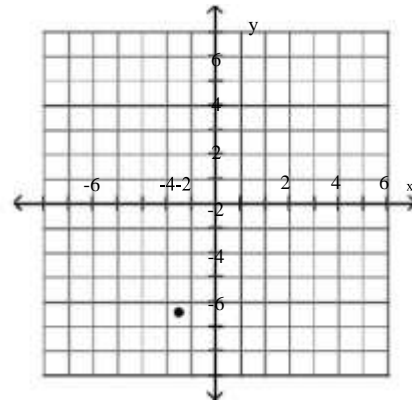

D)

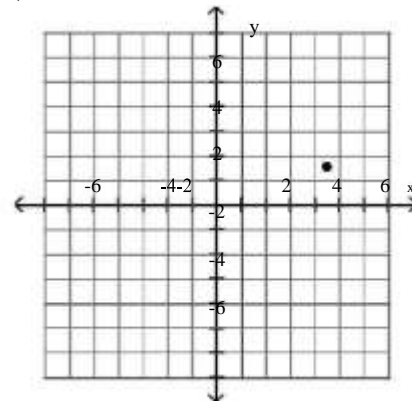

8) $\left(\frac{5}{2}, 0 \right)$

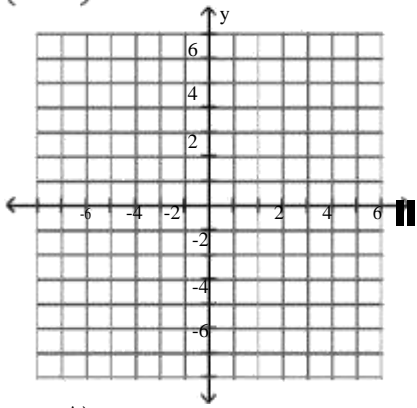

A)

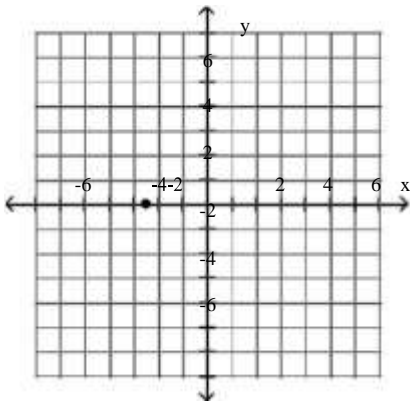

C)

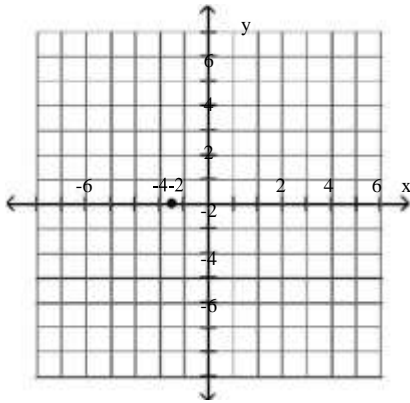

B)

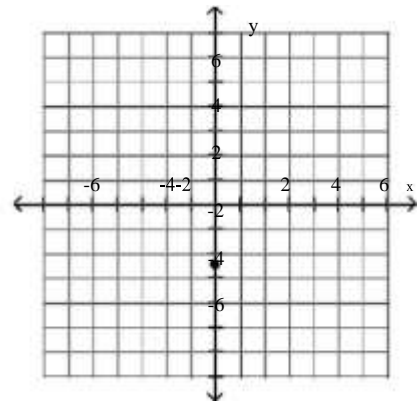

D)

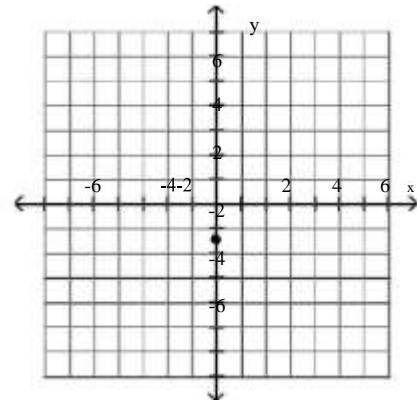

2 Graph Equations in the Rectangular Coordinate System

MULTIPLE CHOICE. Choose the one alternative that best completes the statement or answers the question.

Graph the equation.

1) $y = x + 3$

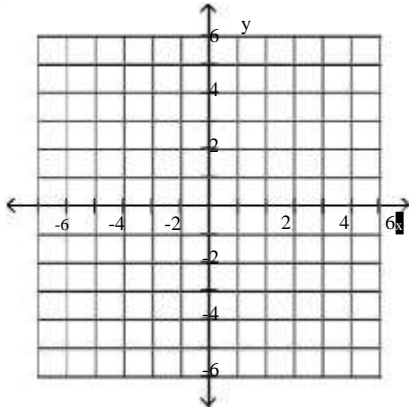

A)

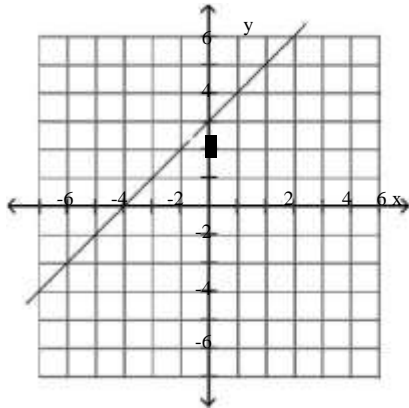

B)

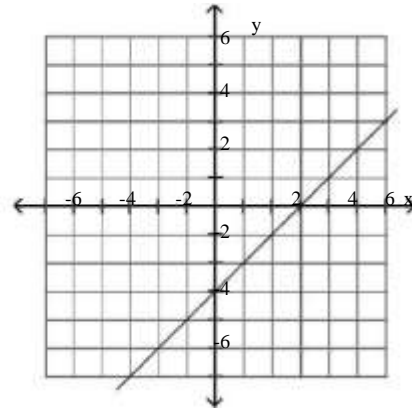

C)

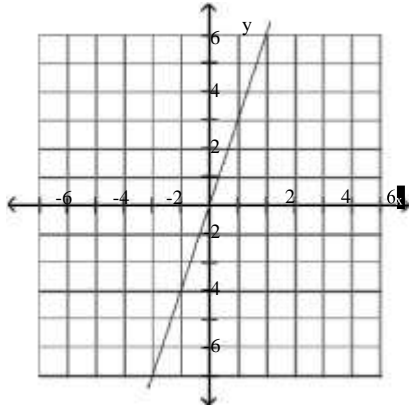

D)

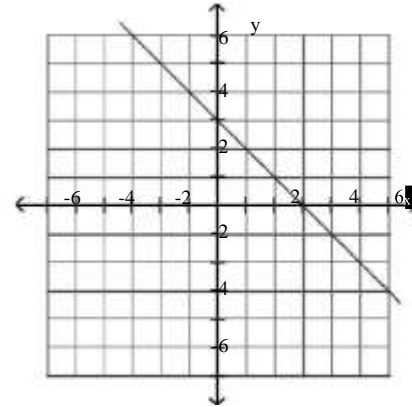

2) $y = 4x - 3$

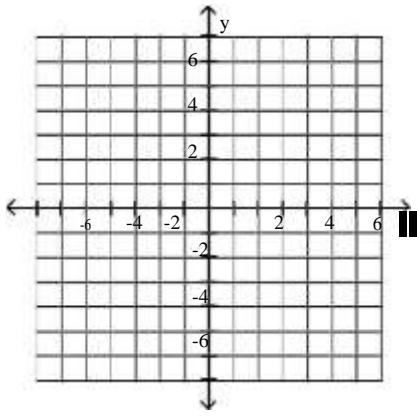

A)

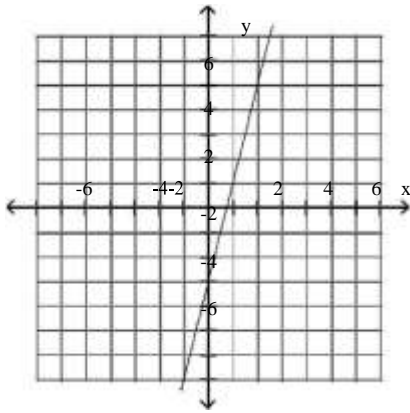

B)

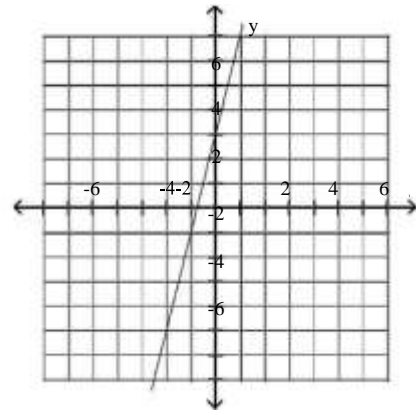

C)

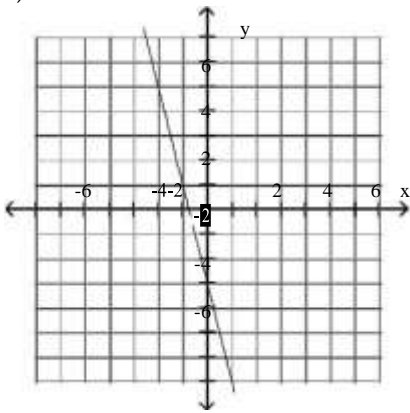

D)

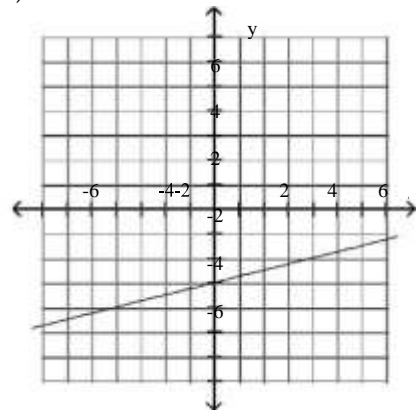

$$3) y = -\frac{1}{3}x + 3$$

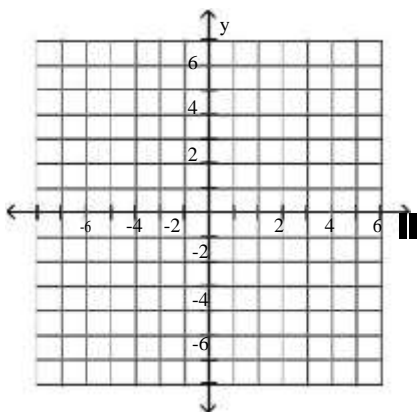

A)

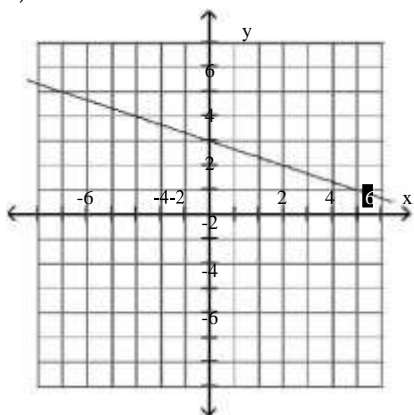

B)

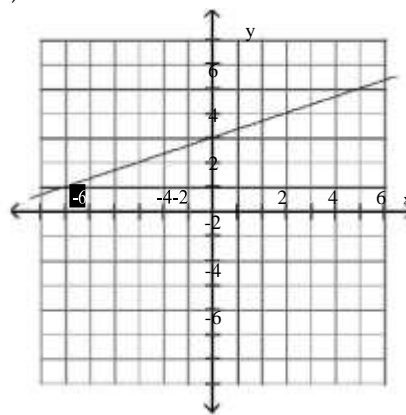

C)

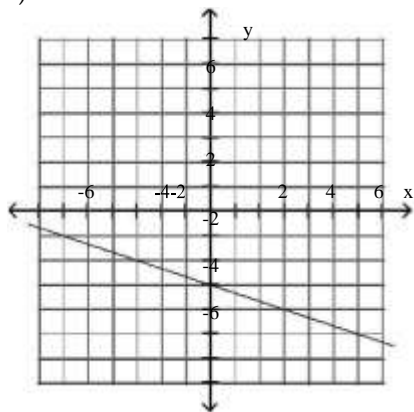

D)

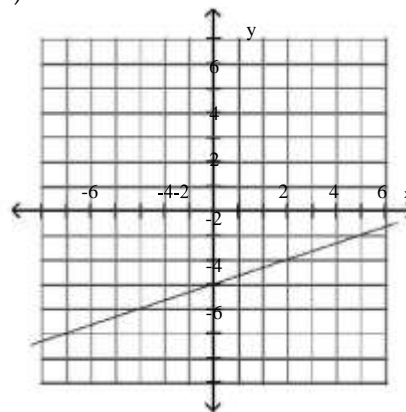

$$4) y = x^2 - 1$$

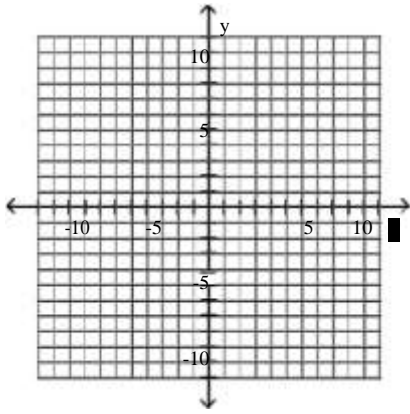

A)

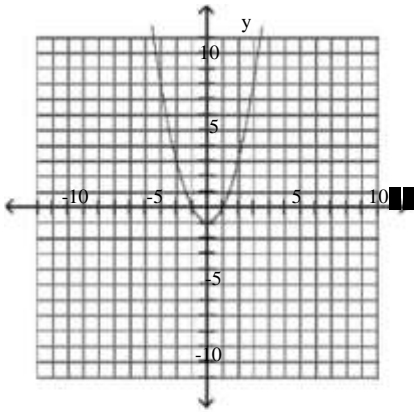

B)

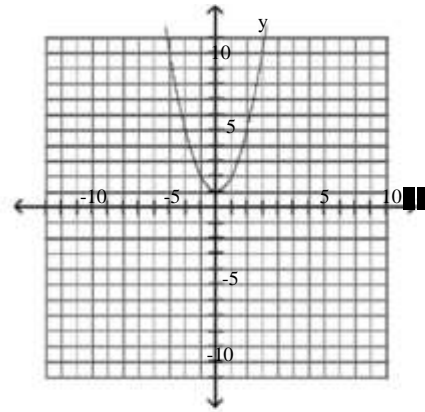

C)

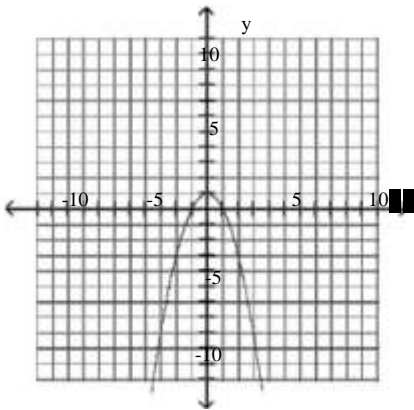

D)

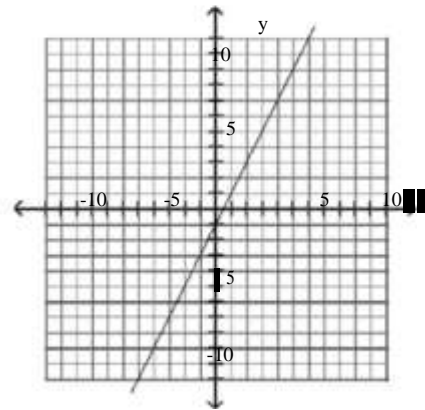

5) $y = x^3 - 5$

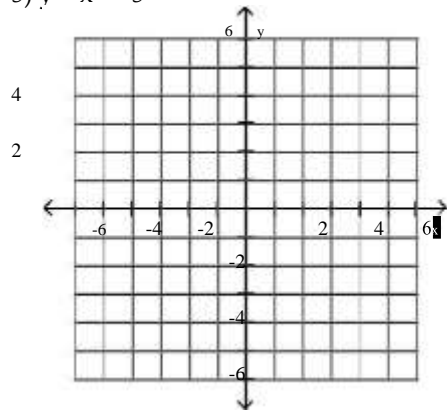

A)

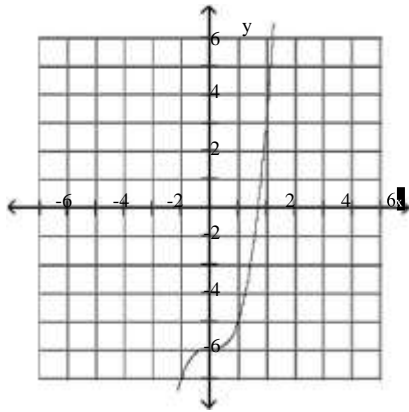

B)

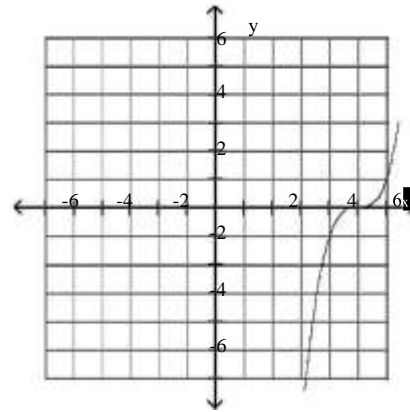

C)

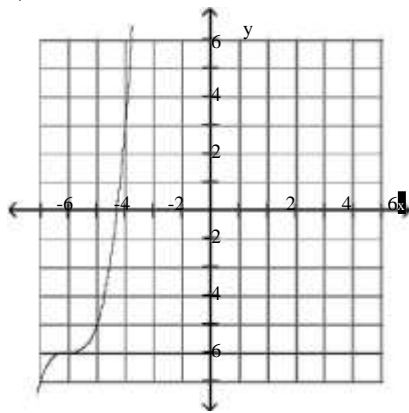

D)

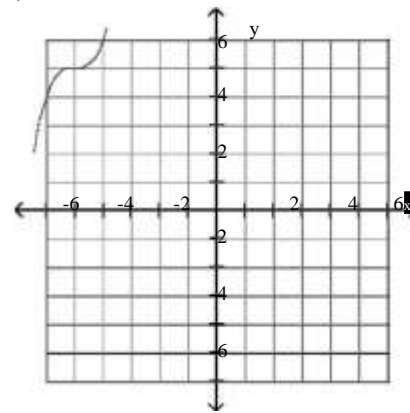

6) $y = -|x - 7|$

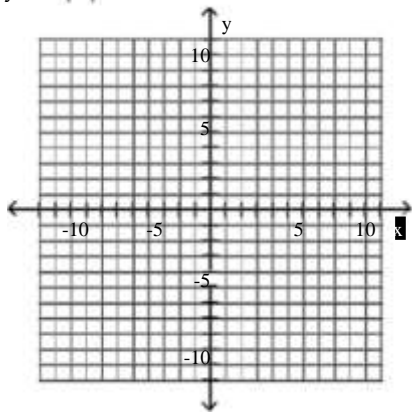

A)

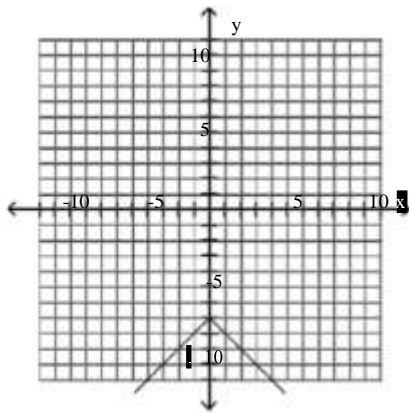

B)

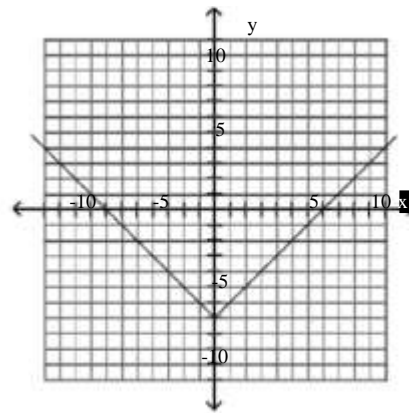

C)

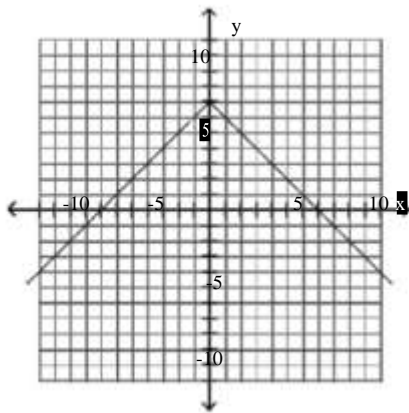

D)

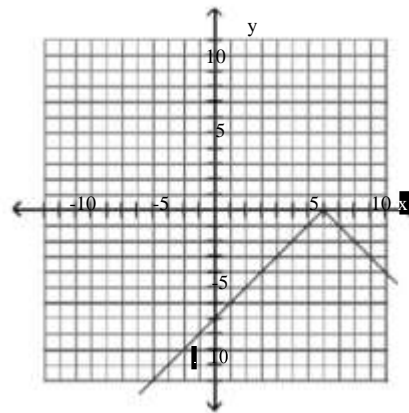

7) $y = 3|x|$

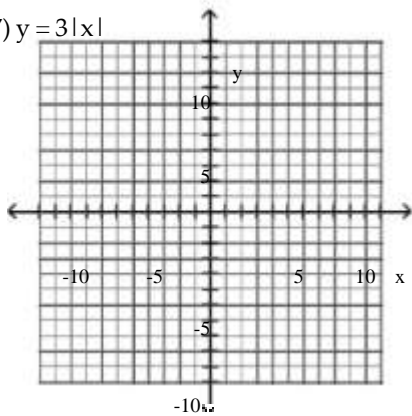

A)

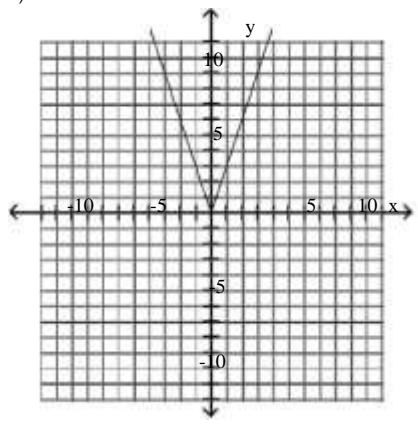

B)

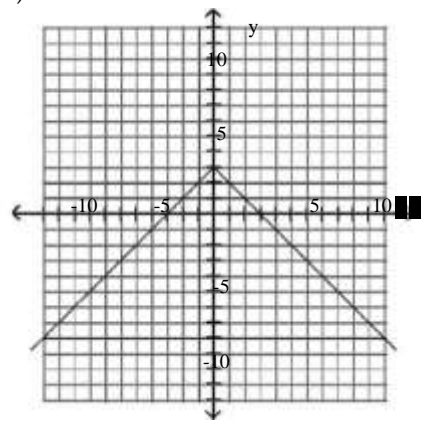

C)

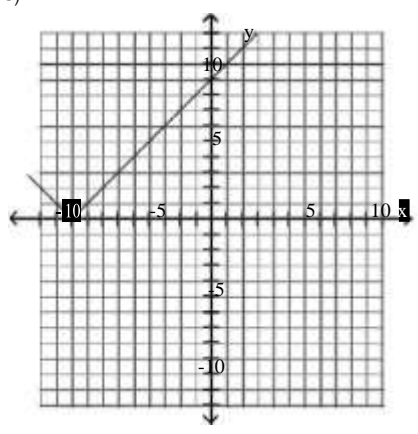

D)

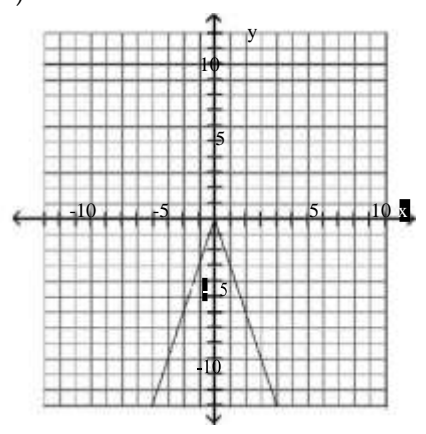

8) $y = -6$

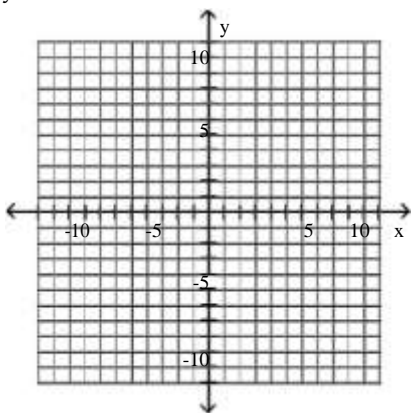

A)

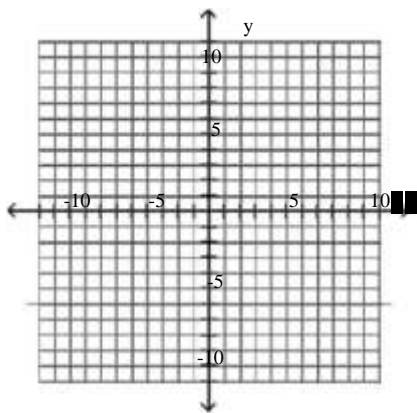

B)

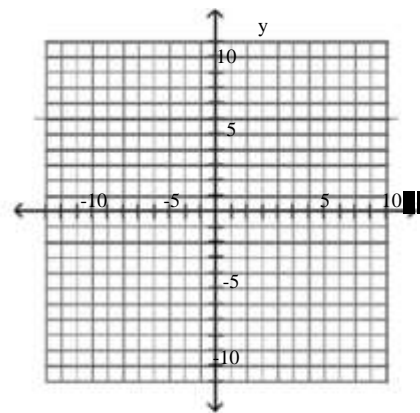

C)

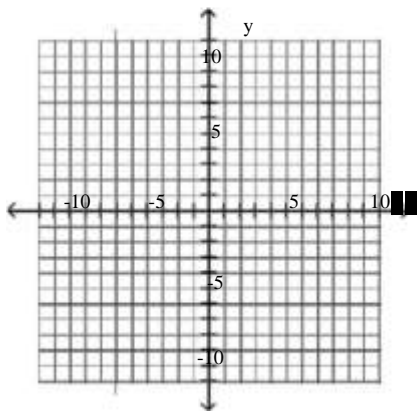

D)

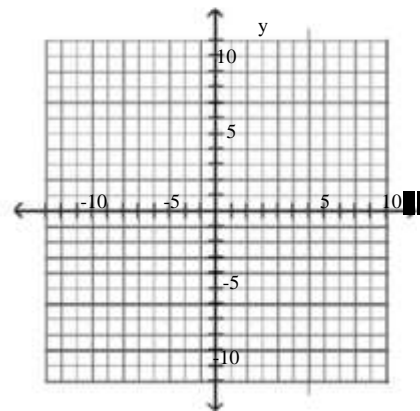

9) $y = \frac{1}{x}$

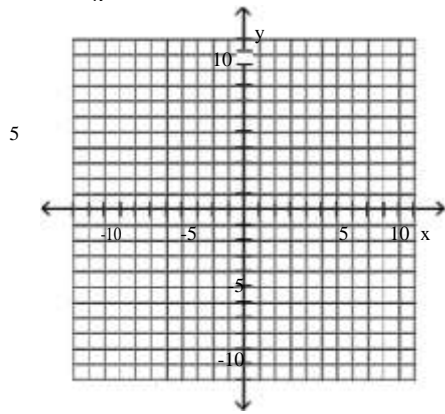

A)

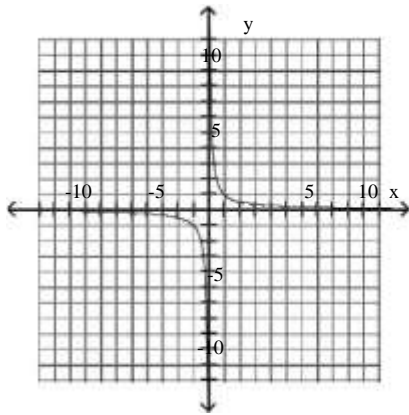

B)

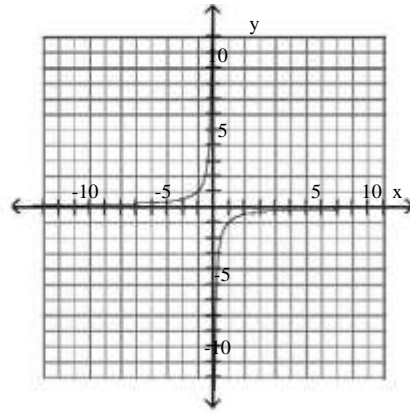

C)

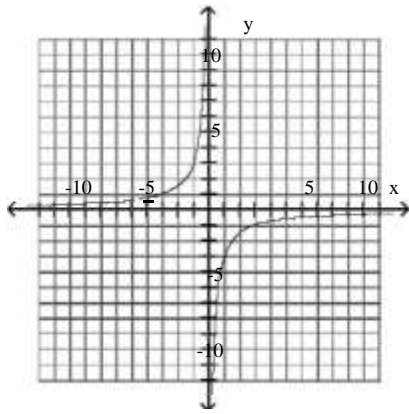

D)

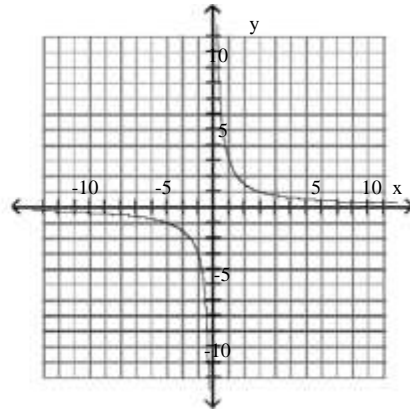

Write the English sentence as an equation in two variables. Then graph the equation.

10) The y-value is five more than three times the x-value.

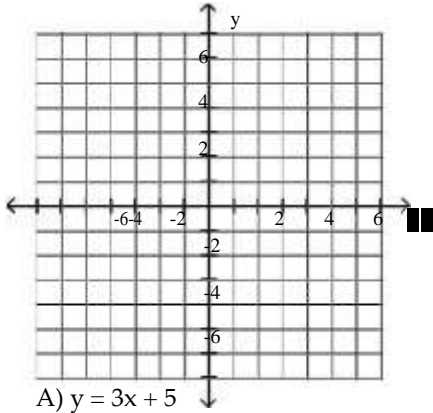

A) $y = 3x + 5$

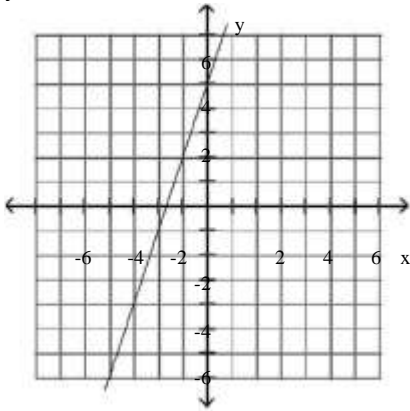

B) $y = -3x + 5$

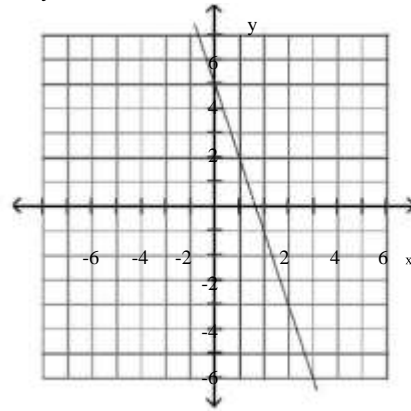

C) $y = -3x - 5$

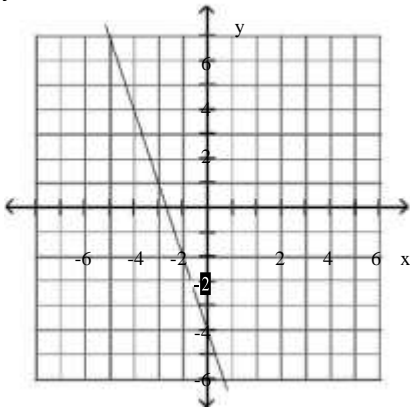

D) $y = 3x - 5$

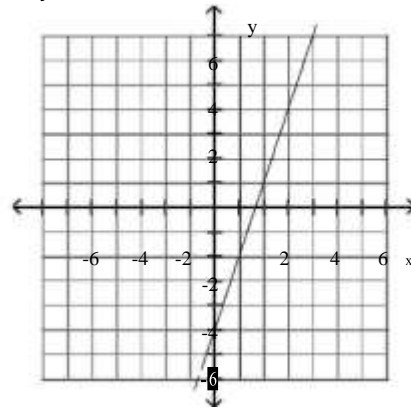

11) The y-value is three decreased by the square of the x-value.

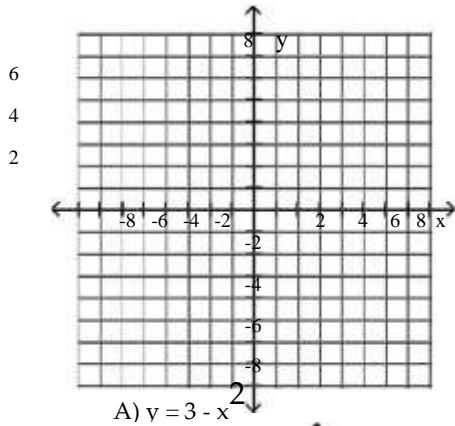

A) $y = 3 - x^2$

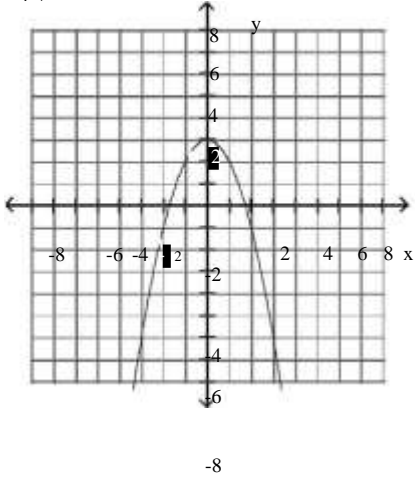

B) $y = 3 - x$

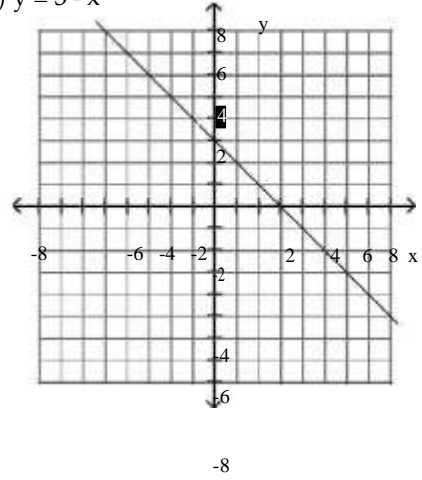

C) $y = x^2 - 3$

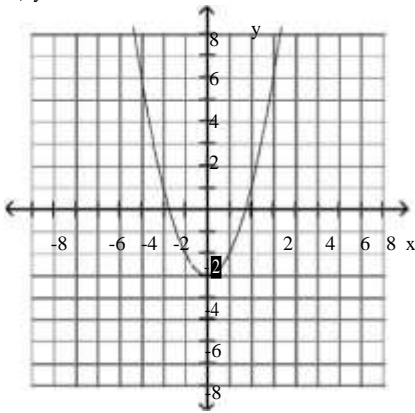

D) $y = x - 3$

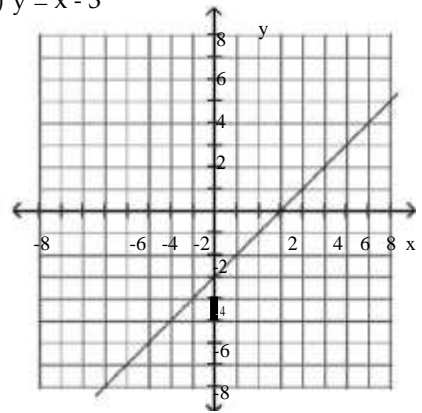

3 Interpret Information About a Graphing Utility's Viewing Rectangle or Table

MULTIPLE CHOICE. Choose the one alternative that best completes the statement or answers the question.

Match the correct viewing rectangle dimensions with the figure.

1)

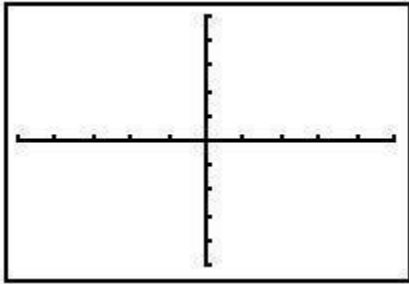

A) [-10, 10, 2] by [-10, 10, 2]

C) [-20, 10, 2] by [-20, 10, 2]

B) [-2, 2, 2] by [-2, 2, 2]

D) [-10, 10, 4] by [-10, 10, 4]

2)

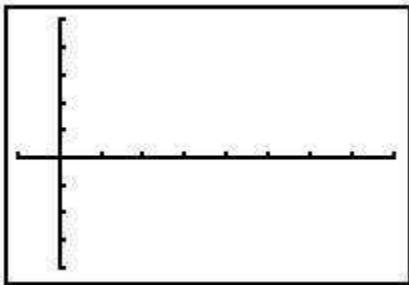

A) [-2, 16, 2] by [-8, 10, 2]

C) [-8, 10, 2] by [-2, 16, 2]

B) [-2, 16, 2] by [-2, 16, 2]

D) [-20, 10, 2] by [-20, 10, 2]

3)

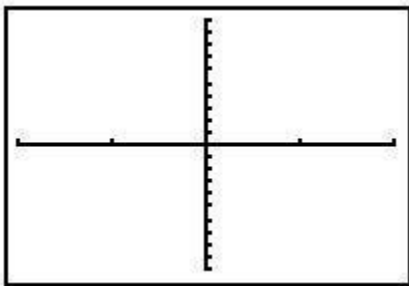

A) [-4, 4, 2] by [-80, 80, 8]

C) [-4, 4, 2] by [-4, 4, 2]

B) [-16, 16, 4] by [-4, 4, 2]

D) [-20, 20, 2] by [-20, 20, 2]

4)



A) $[-20, 60, 20]$ by $[-800, 1000, 200]$

B) $[-2, 16, 2]$ by $[-2, 16, 2]$

C) $[-2, 10, 2]$ by $[-8, 16, 2]$

D) $[-20, 10, 2]$ by $[-20, 10, 2]$

The table of values was generated by a graphing utility with a TABLE feature. Use the following table to solve.

X	Y ₁	Y ₂
-3	9	-3
-2	4	-1
-1	1	1
0	0	3
1	1	5
2	4	7
3	9	9

5) Which equation corresponds to Y₂ in the table?

A) $y_2 = 2x + 3$

B) $y_2 = 2 - 3x$

C) $y_2 = x + 2$

D) $y_2 = 2x - 3$

6) Does the graph of Y₂ pass through the origin?

A) No

B) Yes

7) At which points do the graph of Y₁ and Y₂ intersect?

A) $(-1, 1)$ and $(3, 9)$

B) $(2, 7)$ and $(2, 4)$

C) $(-1, 1)$ and $(2, 7)$

D) $(2, 4)$ and $(3, 9)$

8) For which values of x is Y₁ = Y₂?

A) -1 and 3

B) -2 and 3

C) -1 and -2

D) -2 and 1

4 Use a Graph to Determine Intercepts

MULTIPLE CHOICE. Choose the one alternative that best completes the statement or answers the question.

Use the graph to determine the x - and y-intercepts.

1)

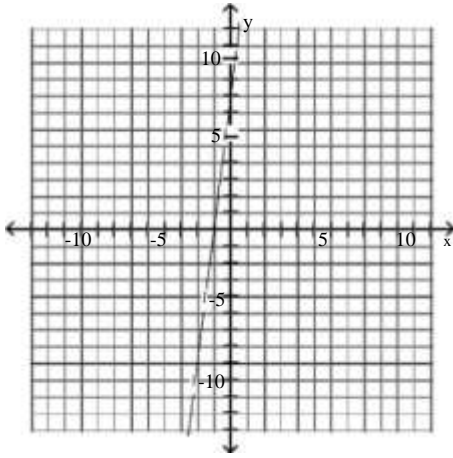

- A) x-intercept: -1; y-intercept: 8
- C) x-intercept: -1; y-intercept: -8

- B) x-intercept: 1; y-intercept: 8
- D) x-intercept: -8; y-intercept: 8

2)

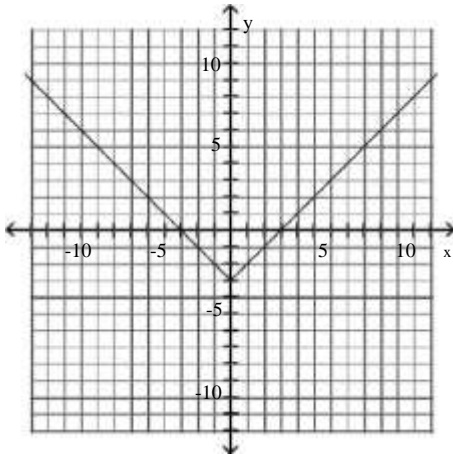

- A) x-intercepts: -3, 3; y-intercept: -3
- C) y-intercept: -3

- B) x-intercepts: -3, 3
- D) x-intercepts: -3, 3; y-intercept: 0

3)

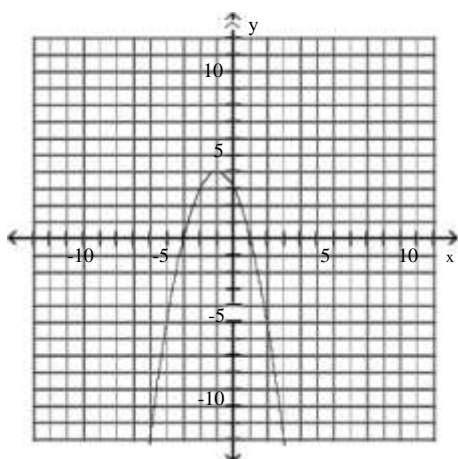

A) x-intercepts: -3, 1; y-intercept: 3

C) x-intercept: 3; y-intercepts: -3, 1

B) x-intercept: -3; y-intercepts: 1, 3

D) x-intercept: 1; y-intercept: 3

4)

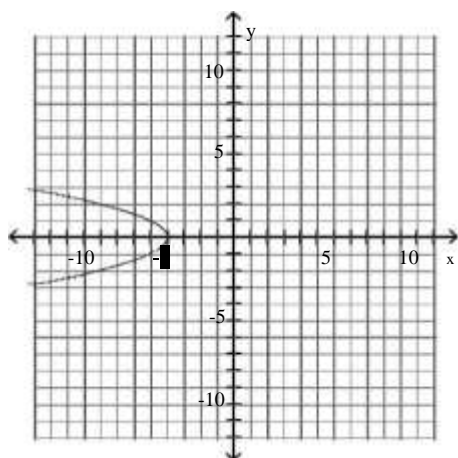

A) x-intercept: -4

B) y-intercept: -4

C) x-intercept: 4

D) y-intercept: 4

5)

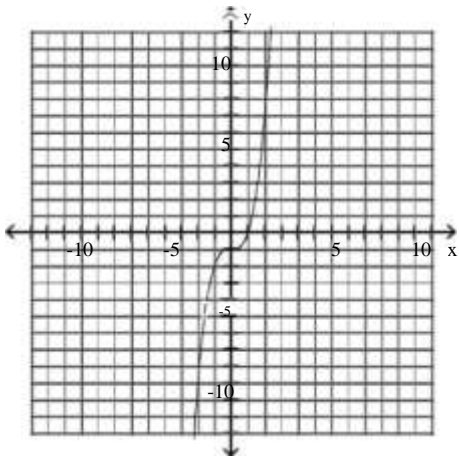

A) x-intercept: 1; y-intercept: -1

C) x-intercept: -1; y-intercept: -1

B) x-intercept: 1; y-intercept: 1

D) x-intercept: -1; y-intercept: 1

6)

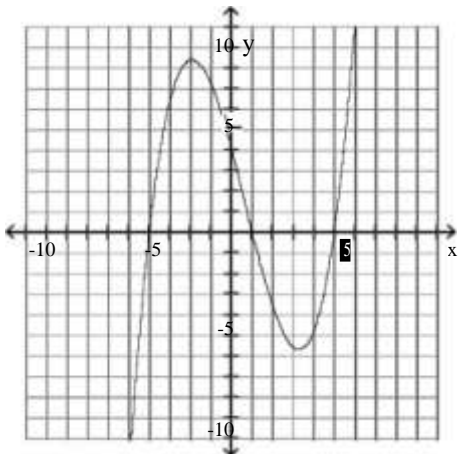

A) x-intercepts: -4, 1, 5; y-intercept: 4

C) x-intercepts: 4, 1, -5; y-intercept: 4

B) x-intercept: 4; y-intercepts: -4, 1, 5

D) x-intercept: 4; y-intercepts: 4, 1, -5

7)

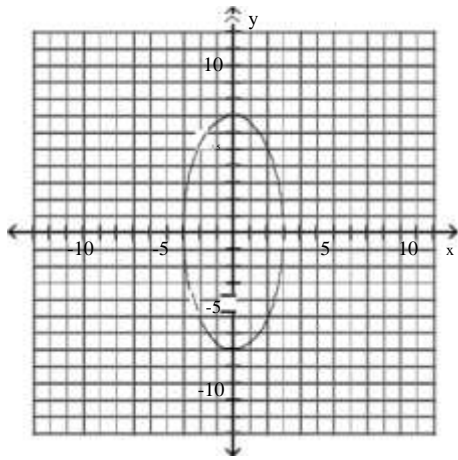

- A) x-intercepts: -3, 3; y-intercepts: -7, 7
- C) y-intercepts: -7, 7

- B) x-intercepts: -3, 3
- D) x-intercepts: -7, 7; y-intercepts: -3, 3

5 Interpret Information Given by Graphs

MULTIPLE CHOICE. Choose the one alternative that best completes the statement or answers the question.

The line graph shows the recorded hourly temperatures in degrees Fahrenheit at an airport.

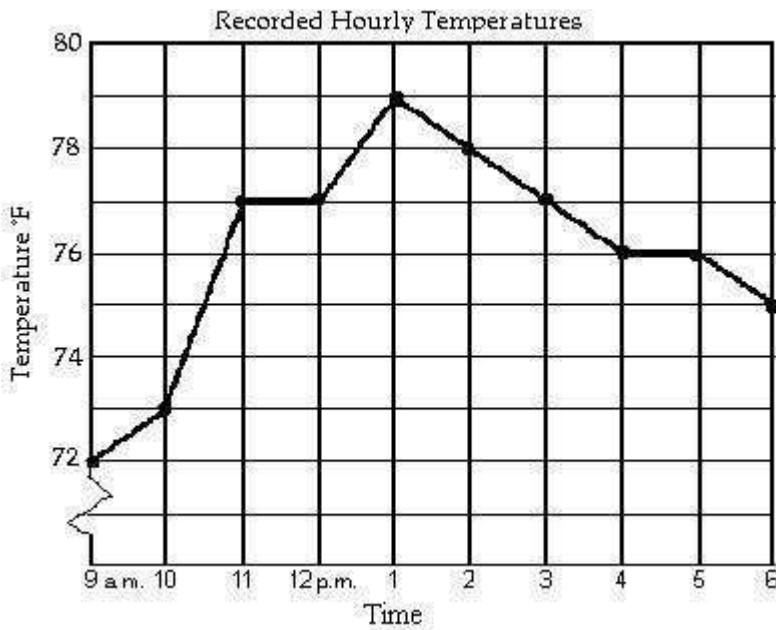

- 1) At what time was the temperature the highest?
 - A) 1 p.m.
 - B) 5 p.m.
 - C) 11 a.m.
 - D) 2 p.m.
- 2) At what time was the temperature its lowest?
 - A) 9 a.m.
 - B) 6 p.m.
 - C) 4 p.m.
 - D) 1 p.m.
- 3) What temperature was recorded at 10 a.m.?
 - A) 73 °F
 - B) 75 °F
 - C) 71 °F
 - D) 74 °F

4) During which hour did the temperature increase the most?

A) 10 a.m. to 11 a.m.

B) 1 p.m. to 2 p.m.

C) 12 p.m. to 1 p.m.

D) 9 a.m. to 10 a.m.

5) At what time was the temperature 72° ?

A) 9 a.m.

B) 10 a.m.

C) 6 p.m.

D) 9 a.m. and 10 a.m.

6) During which two hour period did the temperature increase the most?

A) 9 a.m. to 11 a.m.

B) 10 a.m. to 11 a.m.

C) 12 p.m. to 2 p.m.

D) 10 a.m. to 12 p.m.

Match the story with the correct figure.

7) The amount of rainfall as a function of time, if the rain fell more and more softly.

A)

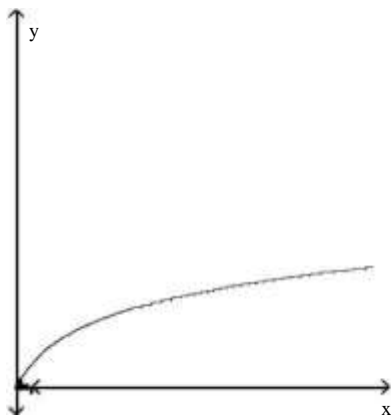

B)

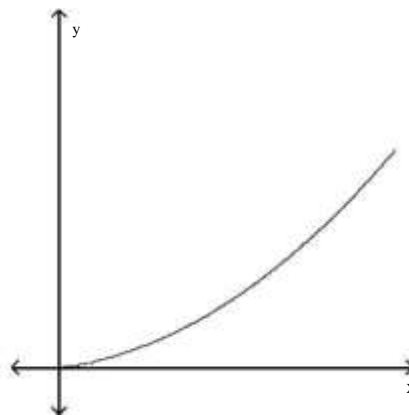

C)

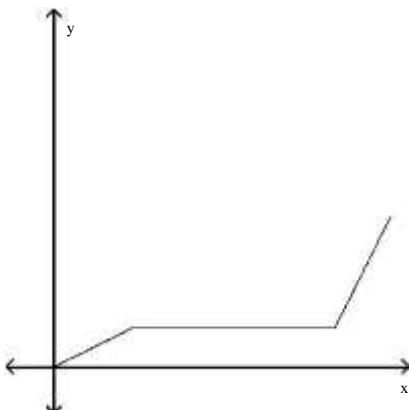

D)

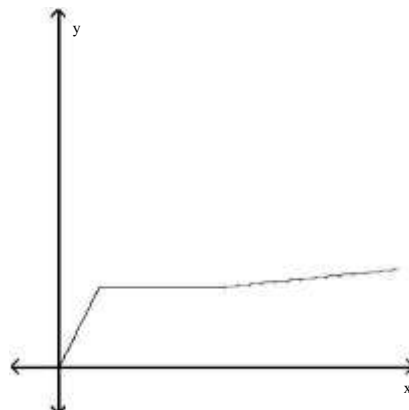

8) The height of an animal as a function of time.

A)

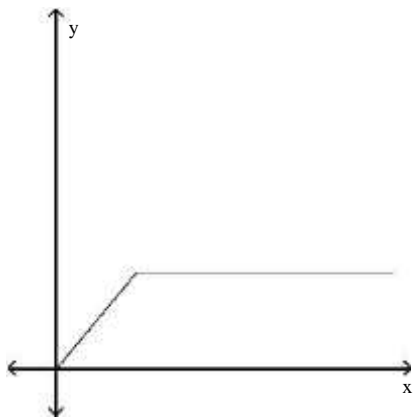

B)

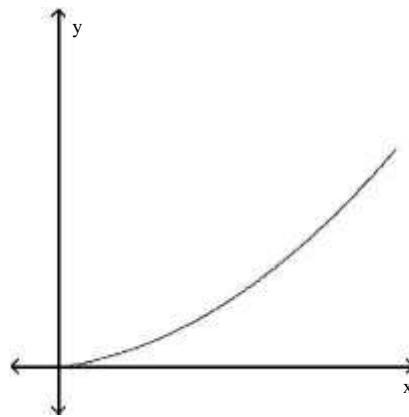

C)

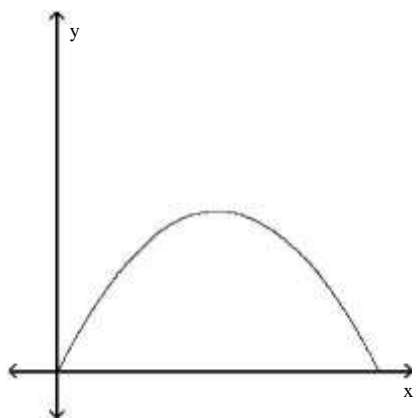

D)

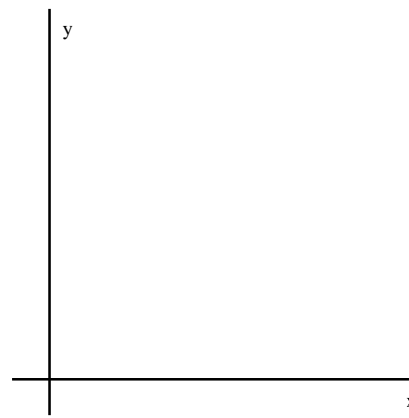

9) Mark started out by walking up a hill for 5 minutes. For the next 5 minutes he walked down a steep hill to an elevation lower than his starting point. For the next 10 minutes he walked on level ground. For the next 10 minutes he walked uphill. Determine which graph of elevation above sea level versus time illustrates the story.

A)

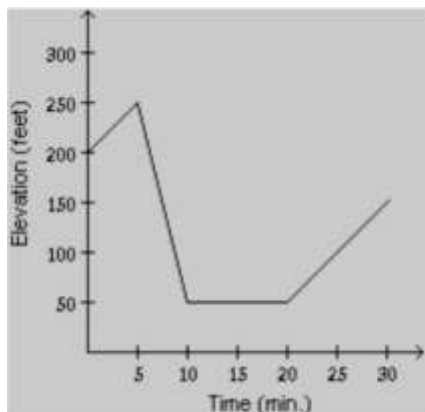

B)

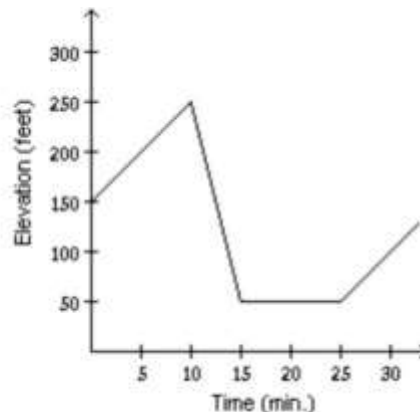

C)

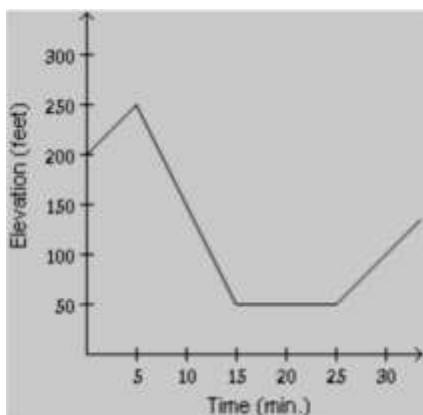

D)

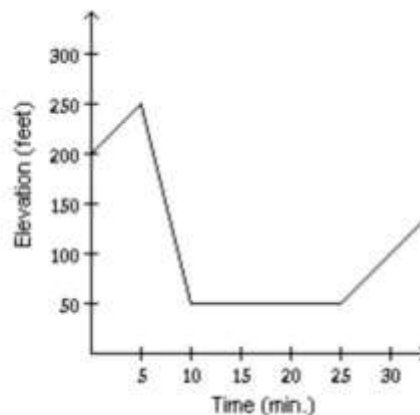

1.2 Linear Equations and Rational Equations

1 Solve Linear Equations in One Variable

MULTIPLE CHOICE. Choose the one alternative that best completes the statement or answers the question.

Solve and check the linear equation.

1) $2x - 2 = 18$

A) {10}

B) {18}

C) {22}

D) {11}

2) $8x - (6x - 1) = 2$

A) $\left\{ \frac{1}{2} \right\}$

B) $\left\{ \frac{1}{14} \right\}$

C) $\left\{ \frac{-1}{2} \right\}$

D) $\left\{ -\frac{1}{14} \right\}$

3) $9x - 1 = -5 + 8x$

A) $\left\{ -4 \right\}$

B) $\left\{ \frac{-1}{4} \right\}$

C) $\left\{ \frac{1}{4} \right\}$

D) $\left\{ \frac{-17}{6} \right\}$

4) $(-4x - 2) + 7 = -3(x + 3)$

A) {14}

B) {- 14}

C) {0}

D) {- 2}

$$5) 6x - 7 + 3(x + 1) = 4x - 6$$

A) $\left\{ -\frac{2}{5} \right\}$

B) $\left\{ -\frac{1}{3} \right\}$

C) $\left\{ -\frac{16}{5} \right\}$

D) $\left\{ -\frac{8}{3} \right\}$

$$6) -2[7x - 7 - 6(x + 1)] = 2x + 5$$

A) $\left\{ -\frac{21}{4} \right\}$

B) $\{ -3 \}$

C) $\left\{ -\frac{7}{4} \right\}$

D) $\{ 1 \}$

$$7) \frac{2}{3} - 2(5 - \frac{2}{2}) = 81x$$

A) $\left\{ -\frac{1}{9} \right\}$

B) $\{ 9 \}$

C) $\{ 0 \}$

D) $\left\{ \frac{7}{9} \right\}$

$$8) 0.08(50) + 0.40x = 0.20(50 + x)$$

A) $\{ 30 \}$

B) $\{ 20 \}$

C) $\{ 40 \}$

D) $\{ 15 \}$

$$9) 0.50x - 0.20(70 + x) = 0.10(70)$$

A) $\{ 70 \}$

B) $\{ 60 \}$

C) $\{ 80 \}$

D) $\{ 35 \}$

Find all values of x satisfying the given conditions.

$$10) y_1 = 8x + 4(3 + x), \quad y_2 = 3(x - 9) + 10x, \quad \text{and } y_1 = y_2$$

A) $\{ 39 \}$

B) $\{ 12 \}$

C) $\{ -39 \}$

D) $\{ -12 \}$

Find all values of x such that $y = 0$.

$$11) y = 2[2x - (3x - 1)] - 9(x - 1)$$

A) $\{ 1 \}$

B) $\{ -1 \}$

C) $\left\{ \frac{7}{11} \right\}$

D) $\left\{ -\frac{7}{11} \right\}$

Solve the problem.

12) There is a relationship between the expected number of tickets sold for a raffle and the dollar value of the prize for the raffle. The equation $T - 8P = 50$ describes this relationship, where T is the expected number of tickets sold, and P is the dollar value of the raffle prize. Suppose the expected ticket sales for a certain raffle are 7250. Substitute 7250 into the equation to determine the dollar value of the raffle prize.

A) \$900

B) \$58,050

C) \$850

D) \$7200

13) The equation $V = -2000t + 23,000$ describes the value in dollars of a certain model of car after it is t years old. If a car is worth \$17,000, substitute 17,000 into the equation to find the age of the car.

A) 3 years

B) 2 years

C) 4 years

D) 5 years

2 Solve Linear Equations Containing Fractions

MULTIPLE CHOICE. Choose the one alternative that best completes the statement or answers the question.

Solve the equation.

$$1) \frac{x}{4} = 7 + 9$$

A) $\{ 84 \}$

B) $\{ 63 \}$

C) $\{ 36 \}$

D) $\{ 28 \}$

$$2) x = \frac{x}{9} + \frac{7}{4} - \frac{7}{9}$$

$$A) \left\{ \begin{array}{l} -28 \\ 5 \end{array} \right\}$$

$$B) \left\{ \begin{array}{l} -7 \\ 9 \end{array} \right\}$$

$$C) 0$$

$$D) \left\{ \begin{array}{l} -5 \\ 28 \end{array} \right\}$$

$$3) 18 - \frac{x}{45} = x$$

$$A) \{40\}$$

$$B) \{81\}$$

$$C) \left\{ \frac{81}{2} \right\}$$

$$D) \{2\}$$

$$4) \frac{2x}{53} = \frac{x}{3} + 3$$

$$A) \{45\}$$

$$B) \{-45\}$$

$$C) \{90\}$$

$$D) \{-90\}$$

$$\frac{3x}{4} - x =$$

$$5) \frac{x}{28} - \frac{8}{7}$$

$$A) \{4\}$$

$$B) \left\{ \frac{-16}{3} \right\}$$

$$\frac{16}{3}$$

$$C) \{3\}$$

$$D) \{-4\}$$

$$6) \frac{x+7}{146} = 2 - \frac{x}{46}$$

$$A) \{1\}$$

$$B) \{21\}$$

$$C) \{0\}$$

$$D) \{48\}$$

$$7) \frac{x}{-89} - \frac{16}{73} + x + 9 = x + 6$$

$$A) \left\{ \begin{array}{l} -216 \\ 73 \end{array} \right\}$$

$$B) \left\{ \begin{array}{l} -18 \\ -73 \end{array} \right\}$$

$$C) \left\{ \frac{126}{73} \right\}$$

$$D) \left\{ \begin{array}{l} -162 \\ 73 \end{array} \right\}$$

Find all values of x satisfying the given conditions.

$$8) y = \frac{x+6}{3}, y = \frac{x+8}{6}, \text{ and } y = y$$

$$A) \{1\}$$

$$B) \{1\}$$

$$C) \{-12\}$$

$$D) \{3\}$$

Find all values of x such that y = 0.

$$9) y = \frac{x+9}{4} + \frac{x-1}{5} - \frac{5}{2}$$

$$A) \{1\}$$

$$B) \{21\}$$

$$C) \{0\}$$

$$D) \{50\}$$

Solve the problem.

10) A certain store has a fax machine available for use by its customers. The store charges \$1.90 to send the first page and \$0.40 for each subsequent page. The total price, P, for the faxing x pages can be modeled by the formula $P = 0.40(x - 1) + 1.90$. Determine the number of pages that can be faxed for \$3.50.

$$A) 5 \text{ pages}$$

$$B) 42 \text{ pages}$$

$$C) 2 \text{ pages}$$

$$D) 9 \text{ pages}$$

- 11) A local race for charity has taken place since 1993. Using the actual speeds of the winners from 1993 through 1998, mathematicians obtained the formula $y = 0.16x + 4.5$, in which x represents the number of years after 1993 and y represents the winning speed in miles per hour. In what year is the winning speed predicted to be 6.1 mph?
- A) 2003 B) 2002 C) 2004 D) 2005
- 12) A car rental agency charges \$150 per week plus \$0.20 per mile to rent a car. The total cost, C , for the renting the car for one week and driving it x miles can be modeled by the formula $C = 0.20x + 150$. How many miles can you travel in one week for \$250?
- A) 500 miles B) 475 miles C) 200 miles D) 1250 miles

3 Solve Rational Equations with Variables in the Denominators

MULTIPLE CHOICE. Choose the one alternative that best completes the statement or answers the question.

First, write the value(s) that make the denominator(s) zero. Then solve the equation.

1) $7 = \frac{1}{x} + 52$

A) $x \neq 0; \left\{ \frac{1}{8} \right\}$

B) $x \neq 0; \{8\}$

C) $x \neq 0, 2; \left\{ \frac{15}{26} \right\}$

D) No restrictions; $\{4\}$

2) $\frac{4}{x} + 9 = \frac{1}{2x} + \frac{16}{3}$

A) $x \neq 0; \left\{ \frac{-21}{22} \right\}$

B) $x \neq 0; \left\{ \frac{-22}{21} \right\}$

C) $x \neq 0, 2, 3; \left\{ \frac{-21}{22} \right\}$

D) No restrictions; $\left\{ \frac{-22}{21} \right\}$

3) $\frac{x-8}{2x} + 5 = \frac{x+6}{x}$

A) $x \neq 0; \left\{ \frac{20}{9} \right\}$

B) $x \neq 0; \{15\}$

C) $x \neq 0, 2; \left\{ \frac{20}{9} \right\}$

D) No restrictions; $\left\{ \frac{7}{5} \right\}$

4) $\frac{30}{x-4} + 5 = \frac{15}{x-4}$

A) $x \neq 4; \{1\}$

B) $x \neq -4; \{1\}$

C) $x \neq -4; \{13\}$

D) $x \neq 4; \emptyset$

5) $\frac{21}{7x-7} + \frac{1}{7} = \frac{3}{x-1}$

A) $x \neq 1; \emptyset$

B) $x \neq 7; \{1\}$

C) $x \neq 1; \{1\}$

D) $x \neq -1, 7; \{1, 7\}$

6) $\frac{2}{x+1} + \frac{3}{x-1} = \frac{6}{(x+1)(x-1)}$

A) $x \neq -1, 1; \emptyset$

B) $x \neq -1, 1; \{2\}$

C) $x \neq -1; \{1\}$

D) No restrictions; $\{1\}$

Solve the equation.

$$7) \frac{x}{2x+2} = \frac{-2x}{4x+4} + \frac{2x-3}{x+1}$$

A) {3}

B) $\left\{ \frac{3}{2} \right\}$

C) {-3}

D) $\left\{ -\frac{12}{5} \right\}$

$$8) y + \frac{4}{y+2} - y - \frac{9}{y-2} = y^2 - 4$$

A) {-7}

B) {7}

C) $\{\sqrt{3}\}$

D) {35}

$$9) x + \frac{1}{x+7} + \frac{3}{x+4} = \frac{-3}{x^2 + 11x + 28}$$

A) \emptyset

B) {-7}

C) {4}

D) {0}

$$10) \frac{m+4}{m^2+3m+2} - \frac{4}{m^2+4m+4} = \frac{m-4}{m^2+3m+2}$$

A) {-3}

B) {-12}

C) {3}

D) {0}

Find all values of x satisfying the given conditions.

$$11) y^1 = \frac{1}{x+7}, y^2 = \frac{5}{x+6}, y^3 = \frac{-1}{x^2+13x+42}, \text{ and } y^1 + y^2 = y^3$$

A) {0}

B) {-7}

C) {6}

D) \emptyset

$$12) y^1 = \frac{4}{x+3}, y^2 = \frac{7}{x-3}, y^3 = \frac{6}{x^2-9}, \text{ and } y^1 - y^2 = y^3$$

A) {-13}

B) {13}

C) $\{\sqrt{3}\}$

D) {39}

Solve the problem.

13) The function $f(x) = \frac{30,000}{x} + \frac{210x}{x}$ models the average cost per unit, $f(x)$, for Electrostuff to manufacture x units of Electrogadget IV. How many units must the company produce to have an average cost per unit of \$360?

A) 200 units

B) 201 units

C) 140 units

D) 143 units

14) Suppose a cost-benefit model is given by $y = \frac{2659x}{100-x}$, where y is the cost for removing x percent of a given $100-x$ pollutant. What percent of pollutant can be removed for \$35,000?

A) 92.9%

B) 108.2%

C) 9.3%

D) 568.3%

15) The U.S. Maritime Administration estimated that the cost per ton of building an oil tanker could be represented

by the model $y = \frac{100,000}{x}$, where y is the cost in dollars per ton and x is the tons (in thousands). What size of $x + 205$ oil tanker (in thousands of tons) can be built for \$200 per ton?

A) 295 thousand tons

B) 247 thousand tons

C) 705 thousand tons

D) 30 thousand tons

4 Recognize Identities, Conditional Equations, and Inconsistent Equations

MULTIPLE CHOICE. Choose the one alternative that best completes the statement or answers the question.

Determine whether the equation is an identity, a conditional equation, or an inconsistent equation.

1) $3(5x + 29) = 15x + 87$

A) Identity

B) Conditional equation

C) Inconsistent equation

2) $8x + 3x = 10x$

A) Identity

B) Conditional equation

C) Inconsistent equation

3) $-2(x + 7) + 52 = 4x - 6(x + 3)$

A) Identity

B) Conditional equation

C) Inconsistent equation

4) $9x + 6(-2x - 6) = -30 - 9x$

A) Identity

B) Conditional equation

C) Inconsistent equation

5) $20x + 5(x + 1) = 25(x + 1) - 20$

A) Identity

B) Conditional equation

C) Inconsistent equation

6) $5x + 3 + 8x - 5 = 9x + 4x - 5$

A) Identity

B) Conditional equation

C) Inconsistent equation

7) $\frac{8x}{x} = 8$

A) Identity

B) Conditional equation

C) Inconsistent equation

8) $\frac{9x}{x - 6} = x - 6 + 5$

A) Identity

B) Conditional equation

C) Inconsistent equation

9) $\frac{3x + 2}{4} + 2 = -\frac{7x}{2}$

A) Identity

B) Conditional equation

C) Inconsistent equation

10) $y + 5 - y - 5 = y^2 - 25$

A) Identity

B) Conditional equation

C) Inconsistent equation

11) $x + 4 + x + 3 = x^2 + 7x + 12$

A) Identity

B) Conditional equation

C) Inconsistent equation

1.3 Models and Applications

1 Use Linear Equations to Solve Problems

MULTIPLE CHOICE. Choose the one alternative that best completes the statement or answers the question.

Use the five-step strategy for solving word problems to find the number or numbers described in the following exercise.

- 1) When four times the number is added to 7 times , the result is 33. What is the number?
A) 3 B) -4.7 C) 4.7 D) 1
- 2) When 4 times a number is subtracted from 7 times the number, the result is 30. What is the number?
A) 10 B) 3 C) -10 D) 0.9
- 3) When a number is decreased by 60% of itself, the result is 144. What is the number?
A) 360 B) 17 C) 600 D) 216
- 4) When 20% of a number is added to the number, the result is 60. What is the number?
A) 50 B) 10 C) 17 D) 120
- 5) 20% of what number is 57?
A) 285 B) 2850 C) 28.5 D) 11.4
- 6) One number exceeds another by -5. The sum of the numbers is -1. What are the numbers?
A) -3 and 2 B) -4 and 3 C) 3 and 3 D) No solution

Find all values of x satisfying the given conditions.

7) $y_1 = 7x$, $y_2 = (4x - 1)$, and y_1 exceeds y_2 by 2.

- A) $\left\{\frac{1}{3}\right\}$ B) $\left\{\frac{1}{11}\right\}$ C) $\left\{\frac{-1}{3}\right\}$ D) $\left\{\frac{-1}{11}\right\}$

8) $y_1 = x$, $y_2 = 8 + x$, $y_3 = 3(x - 3) + 10x$, and the sum of 8 times y_1 and 4 times y_2 equals y_3 .

- A) {41} B) {11} C) {-41} D) {-11}

9) $y_1 = \frac{1}{x+5}$, $y_2 = \frac{1}{x+4}$, $y_3 = \frac{-1}{x^2 + 9x + 20}$, and the sum of y_1 and 3 times y_2 is y_3 .

- A) {0} B) {-5} C) {4} D) \emptyset

10) $y_1 = \frac{1}{x+2}$, $y_2 = \frac{1}{x-2}$, $y_3 = \frac{1}{x^2 - 4}$, and the difference between 4 times y_1 and 6 times y_2 is the product of 6 and y_3 .

- A) {-13} B) {13} C) $\{\sqrt{22}\}$ D) {26}

Solve the problem.

- 11) A car rental agency charges \$250 per week plus \$0.25 per mile to rent a car. How many miles can you travel in one week for \$300?
A) 200 miles B) 175 miles C) 325 miles D) 1200 miles
- 12) A train ticket in a certain city is \$2.50. People who use the train also have the option of purchasing a frequent rider pass for \$18.00 each month. With the pass, each ticket costs only \$1.75. Determine the number of times in a month the train must be used so that the total monthly cost without the pass is the same as the total monthly cost with the pass.
A) 24 times B) 25 times C) 23 times D) 26 times
- 13) You inherit \$10,000 with the stipulation that for the first year the money must be invested in two stocks paying 6% and 11% annual interest, respectively. How much should be invested at each rate if the total interest earned for the year is to be \$800?
A) \$6000 invested at 6%; \$4000 invested at 11% B) \$4000 invested at 6%; \$6000 invested at 11%
C) \$5000 invested at 6%; \$5000 invested at 11% D) \$7000 invested at 6%; \$3000 invested at 11%
- 14) You inherit \$28,000 from a very wealthy grandparent, with the stipulation that for the first year, the money must be invested in two stocks paying 4% and 10% annual interest, respectively. How much should be invested at each rate if the total interest earned for the year is to be \$1600?
A) \$20,000 invested at 4%; \$8000 invested at 10% B) \$8000 invested at 4%; \$20,000 invested at 10%
C) \$10,000 invested at 4%; \$18,000 invested at 10% D) \$18,000 invested at 4%; \$10,000 invested at 10%
- 15) A bookcase is to be constructed as shown in the figure below. The height of the bookcase is 4 feet longer than the length of a shelf. If 20 feet of lumber is available for the entire unit (including the shelves, but NOT the back of the bookcase), find the length and height of the unit.

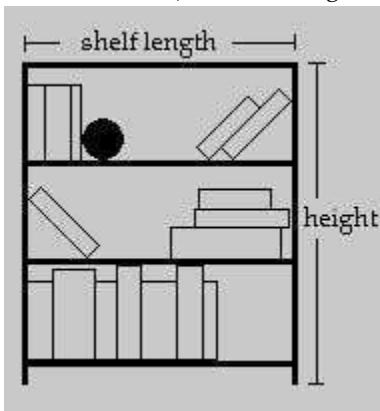

- A) length = 2 feet; height = 6 feet B) length = 8.0 feet; height = 9.0 feet
C) length = 3 feet; height = 7 feet D) length = 2 feet; height = 8 feet
- 16) An auto repair shop charged a customer \$303 to repair a car. The bill listed \$93 for parts and the remainder for labor. If the cost of labor is \$35 per hour, how many hours of labor did it take to repair the car?
A) 6 hours B) 5 hours C) 7 hours D) 6.5 hours

- 17) After a 17% price reduction, a boat sold for \$ 27,390. What was the boat's price before the reduction? (Round to the nearest cent, if necessary.)
- A) \$33,000 B) \$4656.30 C) \$161,117.65 D) \$32,046.30
- 18) Inclusive of a 7.2% sales tax, a diamond ring sold for \$ 2358.40. Find the price of the ring before the tax was added. (Round to the nearest cent, if necessary.)
- A) \$2200 B) \$2528.20 C) \$2188.60 D) \$169.80
- 19) The length of a rectangular room is 6 feet longer than twice the width. If the room's perimeter is 180 feet, what are the room's dimensions?
- A) Width = 28 ft; length = 62 ft B) Width = 56 ft; length = 124 ft
 C) Width = 42 ft; length = 48 ft D) Width = 33 ft; length = 72 ft
- 20) There are 16 more sophomores than juniors in an 8 AM algebra class. If there are 54 students in this class, find the number of sophomores and the number of juniors in the class.
- A) 35 sophomores; 19 juniors B) 19 sophomores; 35 juniors
 C) 70 sophomores; 38 juniors D) 54 sophomores; 38 juniors
- 21) The president of a certain university makes three times as much money as one of the department heads. If the total of their salaries is \$270,000, find each worker's salary.
- A) president's salary = \$202,500; department head's salary = \$67,500
 B) president's salary = \$67,500; department head's salary = \$202,500
 C) president's salary = \$20,250; department head's salary = \$6750
 D) president's salary = \$135,000; department head's salary = \$67,500
- 22) During a road trip, Tony drove one -third the distance that Lana drove. Mark drives 24 more miles than Lana drove. The total distance they drove on the trip was 346 miles. How many miles did each person drive?
- A) Tony drove 46 miles, Lana drove 138 miles, and Mark drove 162 miles.
 B) Tony drove 138 miles, Lana drove 414 miles, and Mark drove 438 miles.
 C) Tony drove 38 miles, Lana drove 114 miles, and Mark drove 138 miles.
 D) Tony drove 414 miles, Lana drove 138 miles, and Mark drove 114 miles.
- 23) The sum of the angles of a triangle is 180° . Find the three angles of the triangle if one angle is four times the smallest angle and the third angle is 24° greater than the smallest angle.
- A) 26° , 104° , 50° B) 17° , 68° , 95° C) 10° , 40° , 130° D) 10° , 34° , 136°
- 24) In a recent International Gymnastics competition, the U.S., China, and Romania were the big winners. If the total number of medals won by each team are three consecutive integers whose sum is 54 and the U.S. won more than China who won more than Romania, how many medals did each team win?
- A) U.S.: 19 medals; China: 18 medals; Romania: 17 medals
 B) U.S.: 20 medals; China: 19 medals; Romania: 18 medals
 C) U.S.: 56 medals; China: 55 medals; Romania: 54 medals
 D) U.S.: 17 medals; China: 16 medals; Romania: 15 medals

25) Sybil is having her yard landscaped. She obtained an estimate from two landscaping companies. Company A gave an estimate of \$190 for materials and equipment rental plus \$45 per hour for labor. Company B gave an estimate of \$280 for materials and equipment rental plus \$30 per hour for labor. Determine how many hours of labor will be required for the two companies to cost the same.

- A) 6 hours B) 5 hours C) 9 hours D) 10 hours

26) Sergio's internet provider charges its customers \$9 per month plus 4¢ per minute of on-line usage. Sergio received a bill from the provider covering a 3-month period and was charged a total of \$61.40. How many minutes did he spend on-line during that period? (Round to the nearest whole minute, if necessary.)

- A) The number of minutes is 860. B) The number of minutes is 536.
 C) The number of minutes is 686. D) The number of minutes is 86.

2 Solve a Formula for a Variable

MULTIPLE CHOICE. Choose the one alternative that best completes the statement or answers the question.

Solve the formula for the specified variable.

1) $A = \frac{1}{2}bh$ for h

- A) $h = \frac{2A}{b}$ B) $h = \frac{b}{2A}$ C) $h = \frac{Ab}{2}$ D) $h = \frac{A}{2b}$

2) $S = 2\pi rh + 2\pi r^2$ for h
 A) $h = \frac{S - \frac{2\pi r^2}{2\pi r}}{2\pi r}$

- B) $h = S - r$ C) $h = \frac{S}{2\pi r} - 1$ D) $h = 2\pi(S - r)$

3) $V = \frac{1}{3}Bh$ for B

- A) $B = \frac{3V}{h}$ B) $B = \frac{3h}{V}$ C) $B = 3h$ D) $B = 3V$

4) $F = \frac{9}{5}C + 32$ for C

- A) $C = \frac{5}{9}(F - 32)$ B) $C = \frac{9}{5}(F - 32)$ C) $C = \frac{F - 32}{9}$ D) $C = \frac{5}{F - 32}$

5) $A = \frac{1}{2}h(a + b)$ for b

- A) $b = \frac{2A - ha}{h}$ B) $b = \frac{ha - 2A}{h}$ B) $r = dt$

6) $d = rt$ for r
 A) $r = \frac{d}{t}$

$$C) b = \frac{2Aa - h}{h}$$

$$D) b = \frac{A - ha}{h}$$

-

$$C) r = \frac{t}{d}$$

$$D) r = d - t$$

-

$$7) P = 2L + 2W \text{ for } L$$

$$A) L = \frac{P - 2W}{2}$$

$$B) L = P - W$$

$$C) L = \frac{P - W}{2}$$

$$D) L = P - 2W$$

8) $A = P(1 + nr)$ for r

A) $r = \frac{A - P}{Pn}$

B) $r = \frac{P - A}{Pn}$

C) $r = \frac{A}{Pn}$

D) $r = \frac{Pn}{A - P}$

9) $I = Prt$ for P

A) $P = \frac{I}{rt}$

$\frac{r - I}{t}$

B) $P = 1 + t$

C) $P = r - It$

D) $P = \frac{r - 1}{It}$

10) $\frac{1}{a} + \frac{1}{b} = \frac{1}{c}$ for c

A) $c = \frac{ab}{a + b}$

B) $c = \frac{a + b}{ab}$

C) $c = a + b$

D) $c = ab(a + b)$

11) $P = 1 + rt$ for t

A) $t = \frac{A - P}{Pr}$

B) $t = \frac{P - A}{1 + r}$

C) $t = P - Ar$

D) $t = \frac{P - 1}{Ar}$

12) $A = \frac{1}{2}h(B + b)$ for b

A) $b = \frac{2A}{h} - \frac{Bh}{h}$

B) $b = 2A - Bh$

C) $b = \frac{A}{h} - \frac{Bh}{h}$

D) $b = \frac{2A + Bh}{h}$

13) $P = s1 + s2 + s3$
for $s2$

A) $s2 = P - s1 - s3$

B) $s2 = P + s1 + s3$

C) $s2 = s1 + s3 - P$

D) $s2 = P + s1 - s3$

14) $I = \frac{nE}{nr + R}$ for n

A) $n = \frac{IR}{-E}$

B) $n = \frac{IR}{Ir + E}$

C) $n = IR(Ir - E)$

D) $n = \frac{-R}{Ir - E}$

1.4 Complex Numbers

1 Add and Subtract Complex Numbers

MULTIPLE CHOICE. Choose the one alternative that best completes the statement or answers the question.

Add or subtract as indicated and write the result in standard form.

1) $(6 - 5i) + (4 + 7i)$

A) $10 + 2i$

B) $10 - 2i$

C) $2 + 12i$

D) $-10 - 2i$

2) $(5 + 6i) - (-7 + i)$

A) $12 + 5i$

B) $12 - 5i$

C) $-2 + 7i$

D) $-12 - 5i$

3) $3i + (-7 - i)$

A) $-7 + 2i$

B) $-7 + 4i$

Page 39

C) $7 - 2i$

D) $7 - 4i$

- 4) $6i - (-3 - i)$
 A) $3 + 7i$ B) $-3 - 7i$ C) $3 - 5i$ D) $-3 + 5i$
- 5) $(-7 + 6i) - 3$
 A) $-10 + 6i$ B) $10 - 6i$ C) $-4 + 6i$ D) $-4 - 6i$
- 6) $6 - (-5 + 7i) - (7 - 2i)$
 A) $4 - 5i$ B) $4 + 5i$ C) $-2 + 5i$ D) $-2 - 5i$
- 7) $(5 - 7i) + (6 - 3i) + (4 - 6i)$
 A) $15 - 16i$ B) $3 - 10i$ C) $7 - 4i$ D) $11 - 10i$

2 Multiply Complex Numbers

MULTIPLE CHOICE. Choose the one alternative that best completes the statement or answers the question.

Find the product and write the result in standard form.

- 1) $-3i(2i - 4)$
 A) $6 + 12i$ B) $-6 + 12i$ C) $12i - 6i^2$ D) $12i + 6i^2$
- 2) $2i(-7i + 3)$
 A) $14 + 6i$ B) $-14 + 6i$ C) $6i - 14i^2$ D) $6i + 14i^2$
- 3) $(9 + 4i)(9 - 8i)$
 A) $113 - 36i$ B) $113 + 36i$ C) $49 + 108i$ D) $-32i^2 - 36i + 81$
- 4) $(-5 - 7i)(2 + i)$
 A) $-3 - 19i$ B) $-17 - 19i$ C) $-3 + 9i$ D) $-17 + 9i$
- 5) $(4 - 9i)(-2 + 6i)$
 A) $46 + 42i$ B) $46 + 6i$ C) $-62 + 42i$ D) $-62 + 6i$
- 6) $(1 + 5i)(1 - 5i)$
 A) 26 B) $1 - 25i^2$ C) -24 D) $1 - 25i$
- 7) $(-5 + i)(-5 - i)$
 A) 26 B) -5 C) 25 D) -24
- 8) $(9 + 8i)^2$
 A) $17 + 144i$ B) $145 + 144i$ C) 17 D) $81 + 144i + 64i^2$

Perform the indicated operations and write the result in standard form.

- 9) $(7 + 8i)(3 - i) - (1 - i)(1 + i)$
 A) $27 + 17i$ B) $31 + 17i$ C) $29 + 17i$ D) $27 + 31i$

$$10) (2 + i)^2 - (3 - i)^2$$

A) $-5 + 10i$

B) $5 + 10i$

C) -15

D) $-5 - 10i$

Complex numbers are used in electronics to describe the current in an electric circuit. Ohm's law relates the current in a circuit, I , in amperes, the voltage of the circuit, E , in volts, and the resistance of the circuit, R , in ohms, by the formula $E = IR$. Solve the problem using this formula.

11) Find E , the voltage of a circuit, if $I = (8 + 4i)$ amperes and $R = (9 + 7i)$ ohms.

A) $(44 + 92i)$ volts

B) $(44 - 92i)$ volts

C) $(92 + 44i)$ volts

D) $(92 - 44i)$ volts

12) Find E , the voltage of a circuit, if $I = (18 + i)$ amperes and $R = (2 + 3i)$ ohms.

A) $(33 + 56i)$ volts

B) $(33 - 56i)$ volts

C) $(-18 + 56i)$ volts

D) $(-18 - 56i)$ volts

3 Divide Complex Numbers

MULTIPLE CHOICE. Choose the one alternative that best completes the statement or answers the question.

Divide and express the result in standard form.

$$\frac{8}{1) 7 - i}$$

A) $\frac{28}{25} + \frac{4}{25}i$

B) $\frac{28}{25} - \frac{4}{25}i$

C) $\frac{7}{6} + \frac{1}{6}i$

D) $\frac{7}{6} - \frac{1}{6}i$

$$\frac{6}{2) 8 + i}$$

A) $\frac{48}{65} - \frac{6}{65}i$

B) $\frac{48}{65} + \frac{6}{65}i$

C) $\frac{16}{21} + \frac{2}{21}i$

D) $\frac{16}{21} - \frac{2}{21}i$

$$\frac{5i}{3) 2 - i}$$

A) $-1 + 2i$

B) $1 + 2i$

C) $-1 + 5i$

D) $-1 - 2i$

$$\frac{3i}{4) 4 - i}$$

A) $-\frac{3}{17} + \frac{12}{17}i$

B) $\frac{3}{17} + \frac{12}{17}i$

C) $-\frac{1}{5} + \frac{4}{5}i$

D) $-\frac{3}{17} - \frac{12}{17}i$

$$\frac{5i}{5) 6 + 5i}$$

A) $\frac{25}{61} + \frac{30}{61}i$

B) $\frac{30}{61} + \frac{25}{61}i$

C) $\frac{25}{11} - \frac{30}{11}i$

D) $\frac{30}{11} + \frac{25}{11}i$

$$\frac{5 + 2i}{6) 2 - 5i}$$

A) i

B) $-i$

C) 1

D) -1

$$\frac{9 + 2i}{7) \text{---} i}$$

A) $\frac{48}{85} - \frac{39}{85}i$

B) $\frac{48}{77} - \frac{39}{77}i$

C) $\frac{12}{17} + \frac{3}{17}i$

D) $\frac{60}{77} - \frac{39}{77}i$

$$8) \frac{7 + 5i}{8 - 7i}$$

$$A) \frac{21}{113} + \frac{89i}{113}$$

$$B) \frac{7}{5} + \frac{89}{113}i$$

$$C) \frac{91}{113} + \frac{9i}{113}$$

$$D) \frac{91}{15} + \frac{89i}{15}$$

$$9) \frac{5 + 3i}{5 + 2i}$$

$$A) \frac{31}{29} + \frac{5}{29}i$$

$$B) \frac{31}{21} + \frac{5}{21}i$$

$$C) \frac{19}{29} - \frac{25}{29}i$$

$$D) \frac{19}{21} + \frac{5}{21}i$$

$$10) \frac{3 + 9i}{7 + 3i}$$

$$A) \frac{24}{29} + \frac{27}{40}i$$

$$B) \frac{3}{5} + \frac{27}{40}i$$

$$C) -\frac{6}{29} - \frac{72}{29}i$$

$$D) -\frac{3}{20} + \frac{27}{40}i$$

$$11) \frac{3 - 3i}{5 - 3i}$$

$$A) \frac{12}{17} - \frac{3}{17}i$$

$$B) \frac{3}{4} - \frac{3}{16}i$$

$$C) \frac{6}{17} + \frac{24}{17}i$$

$$D) \frac{3}{8} - \frac{3}{16}i$$

4 Perform Operations with Square Roots of Negative Numbers

MULTIPLE CHOICE. Choose the one alternative that best completes the statement or answers the question.

Perform the indicated operations and write the result in standard form.

$$1) \sqrt{-25} + \sqrt{81}$$

$$A) 14i$$

$$B) -14i$$

$$C) 45i$$

$$D) -14$$

$$2) \sqrt{-3} - \sqrt{11}$$

$$A) i(\sqrt{3} - 11)$$

$$B) 3i - 11$$

$$C) 3i - 11i$$

$$D) i(\sqrt{3} + 11)$$

$$3) 2\sqrt{-16} + 5\sqrt{-49}$$

$$A) 43i$$

$$B) -43$$

$$C) 43$$

$$D) -43i$$

$$4) 5\sqrt{-48} + 2\sqrt{-27}$$

$$A) \sqrt{3}$$

$$B) -263$$

$$C) 263$$

$$D) -26i3$$

$$5) (-4 - \sqrt{6})^2$$

$$A) \sqrt{20} + 48i$$

$$B) 52 - 48i$$

$$C) 16 + 36i$$

$$D) 16 - 36i$$

$$6) (-7 + \sqrt{-25})^2$$

$$A) 24 - 70i$$

$$B) 74 + 70i$$

$$C) 49 + 25i$$

$$D) 49 - 25i$$

$$7) (10 - \sqrt{-64})(10 + \sqrt{-64})$$

A) 74

B) -54

C) $10 - 64i$

D) $10 - 8i$

8) $(3 + 5i)(2 + -2i)$

A) $(6 - 10i) + (3 + 2\sqrt{2} + 2\sqrt{5})i$

B) $(6 + 10i) - 16i$

C) $-4 - 5 + 10i + \sqrt{2} + \sqrt{5}$

D) $16 + 50i$

9) $\frac{-42 + \sqrt{-180}}{6}$

A) $-7 + i5\sqrt{5}$

B) $-7 - i5\sqrt{5}$

C) $7 + i\sqrt{5}$

D) $-7 + i6\sqrt{5}$

10) $\frac{-18 - \sqrt{-180}}{6}$

A) $-3 - i\sqrt{5}$

B) $-3 + i\sqrt{5}$

C) $3 + i\sqrt{5}$

D) $-3 - i6\sqrt{5}$

11) $\sqrt{-9}(5 - \sqrt{-4})$

A) $27 + 15i$

B) $15i - 27$ C) $15i - 27i^2$ D) $15i + 27i^2$

12) $\sqrt{-16}(\sqrt{-4})$

A) -8

B) $8i^2$

C) 8

D) $-8i$

1.5 Quadratic Equations

1 Solve Quadratic Equations by Factoring

MULTIPLE CHOICE. Choose the one alternative that best completes the statement or answers the question.

Solve the equation by factoring.

1) $x^2 = x + 6$

A) $\{-2, 3\}$

B) $\{2, 3\}$

C) $\{1, 6\}$

D) $\{-2, -3\}$

2) $x^2 + 2x - 48 = 0$

A) $\{-8, 6\}$

B) $\{8, 6\}$

C) $\{-8, 1\}$

D) $\{8, -6\}$

3) $15x^2 + 26x + 8 = 0$

A) $\left\{ \frac{2}{5}, -\frac{4}{3} \right\}$

B) $\left\{ \frac{2}{5}, \frac{4}{3} \right\}$

C) $\left\{ \frac{2}{15}, -\frac{1}{2} \right\}$

D) $\left\{ \frac{2}{5}, -\frac{4}{3} \right\}$

4) $7x^2 - 41x = 6$

A) $\left\{ \frac{1}{7}, \frac{6}{7} \right\}$

B) $\left\{ \frac{1}{7}, \frac{7}{7} \right\}$

C) $\left\{ \frac{1}{41}, -\frac{1}{7} \right\}$

D) $\{-7, 6\}$

5) $14x^2 - 14x = 0$

A) $\{0, 1\}$

B) $\{1, -1\}$

C) $\{0\}$

D) $\{-1, 0\}$

6) $2x(x - 3) = 6x^2 - 7x$

A) $\left\{ -\frac{1}{4}, 0 \right\}$

B) $\left\{ -\frac{1}{4}, 0 \right\}$

C) $\{0, 4\}$

D) $\{0\}$

$$7) 2 - 10x = (3x - 7)(x + 1)$$

A) $\{-3, 1\}$

B) $\{-1, -\frac{7}{3}\}$

C) $\{-1, 3\}$

D) $\{-\frac{1}{5}\}$

$$8) -6x - 2 = (3x + 1)^2$$

A) $\{-1, -\frac{1}{3}\}$

B) $\{-\frac{1}{3}, \frac{1}{3}\}$

C) $\{\frac{1}{3}, 1\}$

D) \emptyset

2 Solve Quadratic Equations by the Square Root Property

MULTIPLE CHOICE. Choose the one alternative that best completes the statement or answers the question.

Solve the equation by the square root property.

$$1) 7x^2 = 112$$

A) $\{-4, 4\}$

B) $\{-4\sqrt{4}, 7\sqrt{4}\}$

C) $\{-7, 7\}$

D) $\{0\}$

$$2) 2x^2 = 26$$

A) $\{-\sqrt{13}, \sqrt{13}\}$

B) $\{14\}$

C) $\{-13, 13\}$

D) $\{13\}$

$$3) 5x^2 + 5 = 725$$

A) $\{-12, 12\}$

B) $\{12\}$

C) $\{-13, 13\}$

D) $\{362.5\}$

$$4) (x - 6)^2 = 16$$

A) $\{2, 10\}$

B) $\{22\}$

C) $\{-4, 4\}$

D) $\{-10, 2\}$

$$5) (2x - 1)^2 = 81$$

A) $\{-4, 5\}$

B) $\{-5, 4\}$

C) $\{-8, 10\}$

D) $\{-10, 8\}$

$$6) (2x + 2)^2 = 16$$

A) $\{-3, 1\}$

B) $\{1, 3\}$

C) $\{-9, 9\}$

D) $\{0, 1\}$

$$7) 4(x - 2)^2 = 20$$

A) $\{2 \pm \sqrt{5}\}$

B) $\{-3, 7\}$

C) $\{-2 \pm \sqrt{5}\}$

D) $\{-7, 3\}$

$$8) (3x + 2)^2 = 6$$

A) $\left\{ -2 - \frac{\sqrt{6}}{3}, -2 + \frac{\sqrt{6}}{3} \right\}$

B) $\left\{ 2 - \frac{\sqrt{6}}{3}, 2 + \frac{\sqrt{6}}{3} \right\}$

C) $\left\{ \frac{\sqrt{6}}{3} - 2, \frac{\sqrt{6}}{3} + 2 \right\}$

D) $\left\{ \frac{8 - \sqrt{6}}{3}, \frac{8 + \sqrt{6}}{3} \right\}$

$$9) (3x - 2)^2 = 20$$

A) $\left\{ \frac{2 - \sqrt{20}}{3}, \frac{2 + \sqrt{20}}{3} \right\}$

B) $\{-2\sqrt{3}, 2\sqrt{3}\}$

C) $\left\{ \frac{-2 - \sqrt{20}}{3}, \frac{-2 + \sqrt{20}}{3} \right\}$

D) $\left\{ -6, \frac{22}{3} \right\}$

$$10) (x - 10)^2 = -49$$

A) $\{10 \pm 7i\}$

B) $\left\{ \pm \frac{7i}{10} \right\}$

C) $\{-10 \pm 7i\}$

D) $\{10i \pm 7\}$

$$11) (x - 7)^2 = -7$$

A) $\{7 \pm i\sqrt{7}\}$

B) $\{7 \pm \sqrt{7}\}$

C) $\{-7 \pm 7i\}$

D) $\{0, 14\}$

3 Solve Quadratic Equations by Completing the Square

MULTIPLE CHOICE. Choose the one alternative that best completes the statement or answers the question.

Determine the constant that should be added to the binomial so that it becomes a perfect square trinomial. Then write and factor the trinomial.

1) $x^2 + 12x$

A) $36; x^2 + 12x + 36 = (x + 6)^2$

B) $6; x^2 + 12x + 6 = (x + 36)^2$

C) $144; x^2 + 12x + 144 = (x + 12)^2$

D) $12; x^2 + 12x + 12 = (x + 144)^2$

2) $x^2 - 12x$

A) $36; x^2 - 12x + 36 = (x - 6)^2$

B) $-36; x^2 - 12x - 36 = (x - 6)^2$

C) $-144; x^2 - 12x - 144 = (x - 12)^2$

D) $144; x^2 - 12x + 144 = (x - 12)^2$

3) $x^2 - 11x$

A) $\frac{121}{4}; x^2 - 11x + \frac{121}{4} = \left(x - \frac{11}{2}\right)^2$

B) $-\frac{121^4}{4}; x^2 - 11x - \frac{121^4}{4} = \left(x - \frac{11}{2}\right)^2$

C) $112; x^2 - 11x + \frac{112}{2} = \left(x - \frac{11}{2}\right)^2$

D) $121; x^2 - 11x + 121 = (x - 11)^2$

4) $x^2 + \frac{1}{4}x$

A) $\frac{1}{64}; x^2 + \frac{1}{4}x + \frac{1}{64} = \left(x + \frac{1}{8}\right)^2$

B) $\frac{1}{16}; x^2 + \frac{1}{4}x + \frac{1}{16} = \left(x + \frac{1}{4}\right)^2$

C) $\frac{1}{8}; x^2 + \frac{1}{4}x + \frac{1}{8} = \left(x + \frac{1}{4}\right)^2$

D) $64; x^2 + \frac{1}{4}x + 64 = (x + 8)^2$

5) $x^2 + \frac{4}{7}x$

A) $\frac{4}{49}; x^2 + \frac{4}{7}x + \frac{4}{49} = \left(x + \frac{2}{7}\right)^2$

B) $49^8; x^2 + \frac{4}{7}x + 49^8 = \left(x + \frac{4}{7}\right)^2$

C) $\frac{4}{7}; x^2 + \frac{4}{7}x + \frac{4}{7} = \left(x + \frac{2}{7}\right)^2$

D) $\frac{49^2}{49}; x^2 + \frac{4}{7}x + 49^2 = \left(x + \frac{2}{7}\right)^2$

6) $x^2 - \frac{2}{3}x$

A) $\frac{1}{9}; x^2 - \frac{2}{3}x + \frac{1}{9} = \left(x - \frac{1}{3}\right)^2$

B) $\frac{1}{9}; x^2 - \frac{2}{3}x + \frac{1}{9} = \left(x + \frac{1}{3}\right)^2$

$$\begin{array}{cccc} 9 & 3 & 9 & 3 \\ \frac{4}{x} & 2 & 2 & 4 & 2 & 2 \end{array}$$

C) $-x + \quad = x -$

9 3 9 3

9 3 9 3

Solve the equation by completing the square.

7) $x^2 + 4x = 7$

A) $\{-2 - \sqrt{11}, -2 + \sqrt{11}\}$

C) $\{-1 - \sqrt{11}, -1 + \sqrt{11}\}$

B) $\{2 + \sqrt{11}\}$

D) $\{-2 - \sqrt{11}, -2 + \sqrt{11}\}$

8) $x^2 + 12x + 11 = 0$

A) $\{-11, -1\}$

B) $\{1, 11\}$

C) $\{-11, 11\}$

D) $\{-11, 22\}$

9) $x^2 + 12x + 17 = 0$

A) $\{-6 - \sqrt{19}, -6 + \sqrt{19}\}$

C) $\{6 - \sqrt{17}, 6 + \sqrt{17}\}$

B) $\{6 + \sqrt{19}\}$

D) $\{-12 + \sqrt{17}\}$

10) $x^2 + 4x - 3 = 0$

A) $\{-2 - \sqrt{7}, -2 + \sqrt{7}\}$

C) $\{-1 - \sqrt{7}, -1 + \sqrt{7}\}$

B) $\{2 + \sqrt{7}\}$

D) $\{-2 - \sqrt{7}, -2 + \sqrt{7}\}$

11) $x^2 - 4x - 7 = 0$

A) $\{2 - \sqrt{11}, 2 + \sqrt{11}\}$

C) $\{-2 - \sqrt{11}, -2 + \sqrt{11}\}$

B) $\{2 - \sqrt{7}, 2 + \sqrt{7}\}$

D) $\{4 - \sqrt{23}, 4 + \sqrt{23}\}$

12) $x^2 + 3x - 9 = 0$

A) $\left\{ \frac{-3 - \sqrt{35}}{2}, \frac{-3 + \sqrt{35}}{2} \right\}$

C) $\left\{ \frac{-3 - \sqrt{35}}{2} \right\}$

B) $\left\{ \frac{3 + \sqrt{35}}{2} \right\}$

D) $\{-3 - \sqrt{35}, -3 + \sqrt{35}\}$

13) $x^2 + 8x + 25 = 0$

A) $\{-4 \pm 3i\}$

B) $\{-4 \pm 9i\}$

C) $\{-4 + 3i\}$

D) $\{-7, -1\}$

14) $x^2 + x + 7 = 0$

A) $\left\{ \frac{-1 \pm 3i}{2} \right\}$

B) $\left\{ \frac{1 \pm 3i}{2} \right\}$

C) $\left\{ \frac{1 \pm 3i}{2} \right\}$

D) $\left\{ \frac{-1 \pm 3i}{2} \right\}$

15) $7x^2 - 2x - 4 = 0$

A) $\left\{ \frac{1 - \sqrt{29}}{7}, \frac{1 + \sqrt{29}}{7} \right\}$

C) $\left\{ -4, \frac{30}{7} \right\}$

B) $\left\{ \frac{7 - \sqrt{29}}{49}, \frac{7 + \sqrt{29}}{49} \right\}$

D) $\left\{ -1 - \frac{\sqrt{29}}{7}, -1 + \frac{\sqrt{29}}{7} \right\}$

$$16) 16x^2 - 7x + 1 = 0$$

$$A) \left\{ \frac{-7 \pm i\sqrt{15}}{32} \right\}$$

$$C) \left\{ \frac{-7 - i\sqrt{15}}{32}, \frac{-7 + i\sqrt{15}}{32} \right\}$$

$$B) \left\{ \frac{-7 \pm i\sqrt{15}}{32}, \frac{-7 \pm \sqrt{15}}{32} \right\}$$

$$D) \left\{ \frac{-7 \pm \sqrt{15}}{32} \right\}$$

4 Solve Quadratic Equations Using the Quadratic Formula

MULTIPLE CHOICE. Choose the one alternative that best completes the statement or answers the question.

Solve the equation using the quadratic formula.

$$1) x^2 + 2x - 99 = 0$$

$$A) \{-11, 9\}$$

$$B) \{11, 9\}$$

$$C) \{-11, 1\}$$

$$D) \{-9, 11\}$$

$$2) x^2 + 5x + 5 = 0$$

$$A) \left\{ \frac{-5 - \sqrt{5}, \frac{-5 + \sqrt{5}}{2}}{2} \right\}$$

$$C) \left\{ \frac{-5 - \sqrt{5}}{10}, \frac{-5 + \sqrt{5}}{10} \right\}$$

$$B) \left\{ 5 - \frac{\sqrt{5}, 5 + \sqrt{5}}{2} \right\}$$

$$D) \left\{ \frac{-5 - 3\sqrt{5}, -5 + 3\sqrt{5}}{2} \right\}$$

$$3) 2x^2 + 10x + 3 = 0$$

$$A) \left\{ \frac{-5 - \sqrt{19}, -5 + \sqrt{19}}{2} \right\}$$

$$C) \left\{ \frac{-10 - \sqrt{19}, -10 + \sqrt{19}}{2} \right\}$$

$$B) \left\{ \frac{-5 - \sqrt{19}, -5 + \sqrt{19}}{4} \right\}$$

$$D) \left\{ \frac{-5 - \sqrt{31}, -5 + \sqrt{31}}{2} \right\}$$

$$4) 5x^2 + x - 3 = 0$$

$$A) \left\{ \frac{-1 - \sqrt{61}, -1 + \sqrt{61}}{10} \right\}$$

$$C) \left\{ \frac{1 - \sqrt{61}, 1 + \sqrt{61}}{10} \right\}$$

$$B) \left\{ \frac{-1 - \sqrt{61}, -1 + \sqrt{61}}{2} \right\}$$

$$D) \emptyset$$

$$5) 7x^2 = -8x - 2$$

$$A) \left\{ \frac{-4 - \sqrt{2}, -4 + \sqrt{2}}{7} \right\}$$

$$C) \left\{ \frac{-8 - \sqrt{2}, -8 + \sqrt{2}}{7} \right\}$$

$$B) \left\{ \frac{-4 - 2\sqrt{2}, -4 + 2\sqrt{2}}{14} \right\}$$

$$D) \left\{ \frac{-4 - \sqrt{30}, -4 + \sqrt{30}}{7} \right\}$$

$$6) x^2 + 10x + 29 = 0$$

$$A) \{-5 + 2i, -5 - 2i\}$$

$$B) \{-5 - 4i, -5 + 4i\}$$

$$C) \{-5 + 2i\}$$

$$D) \{-3, -7\}$$

$$7) 7x^2 + 9x + 4 = 0$$

$$A) \left\{ \frac{-9 \pm i\sqrt{31}}{14} \right\}$$

$$B) \left\{ \frac{-9 \pm \sqrt{31}}{14} \right\}$$

$$C) \left\{ \frac{9 \pm i\sqrt{31}}{14} \right\}$$

$$D) \left\{ \frac{9 \pm \sqrt{31}}{14} \right\}$$

$$8) 16x^2 + 1 = 5x$$

$$A) \left\{ \frac{5 \pm \sqrt{39}}{32} \right\}$$

$$B) \left\{ \frac{-5 \pm \sqrt{39}}{32} \right\}$$

$$C) \left\{ \frac{-5 \pm \sqrt{89}}{32} \right\}$$

$$D) \left\{ \frac{-5 \pm i\sqrt{39}}{32} \right\}$$

5 Use the Discriminant to Determine the Number and Type of Solutions

MULTIPLE CHOICE. Choose the one alternative that best completes the statement or answers the question.

Compute the discriminant. Then determine the number and type of solutions for the given equation.

$$1) x^2 - 4x + 3 = 0$$

- A) 4; two unequal real solutions
- B) -28; two complex imaginary solutions
- C) 0; one real solution

$$2) x^2 + 12x + 36 = 0$$

- A) 0; one real solution
- B) 144; two unequal real solutions
- C) -144; two complex imaginary solutions

$$3) 4x^2 = 6x - 3$$

- A) -12; two complex imaginary solutions
- B) 84; two unequal real solutions
- C) 0; one real solution

6 Determine the Most Efficient Method to Use When Solving a Quadratic Equation

MULTIPLE CHOICE. Choose the one alternative that best completes the statement or answers the question.

Solve the equation by the method of your choice.

$$1) (9x + 3)^2 = 4$$

$$A) \left\{ -\frac{5}{9}, -\frac{1}{9} \right\}$$

$$B) \left\{ \frac{1}{9}, \frac{5}{9} \right\}$$

$$C) \left\{ \frac{1}{9}, 0 \right\}$$

$$D) \left\{ \frac{1}{9} \right\}$$

$$2) 6x^2 - 47x - 8 = 0$$

$$A) \left\{ \frac{1}{6}, \frac{8}{6} \right\}$$

$$B) \left\{ -\frac{1}{6}, \frac{6}{6} \right\}$$

$$C) \left\{ \frac{1}{6}, -\frac{1}{47} \right\}$$

$$D) \{-6, 8\}$$

$$3) 3x^2 + 8x = -1$$

$$A) \left\{ \frac{-4 - \sqrt{13}}{3}, \frac{-4 + \sqrt{13}}{3} \right\}$$

$$B) \left\{ \frac{-4 - \sqrt{13}}{6}, \frac{-4 + \sqrt{13}}{6} \right\}$$

$$C) \left\{ \frac{-8 - \sqrt{13}}{3}, \frac{-8 + \sqrt{13}}{3} \right\}$$

$$D) \left\{ \frac{-4 - \sqrt{19}}{3}, \frac{-4 + \sqrt{19}}{3} \right\}$$

4) $4x^2 = -10x - 3$

A) $\left\{ \frac{-5 - \sqrt{13}}{4}, \frac{-5 + \sqrt{13}}{4} \right\}$
 C) $\left\{ \frac{-10 - \sqrt{13}}{4}, \frac{-10 + \sqrt{13}}{4} \right\}$

B) $\left\{ \frac{-5 - \sqrt{13}}{8}, \frac{-5 + \sqrt{13}}{8} \right\}$
 D) $\left\{ \frac{-5 - \sqrt{37}}{4}, \frac{-5 + \sqrt{37}}{4} \right\}$

5) $3x^2 + 12x + 7 = 0$

A) $\left\{ \frac{-6 - \sqrt{15}}{3}, \frac{-6 + \sqrt{15}}{3} \right\}$
 C) $\left\{ \frac{-12 - \sqrt{15}}{3}, \frac{-12 + \sqrt{15}}{3} \right\}$

B) $\left\{ \frac{-6 - \sqrt{15}}{6}, \frac{-6 + \sqrt{15}}{6} \right\}$
 D) $\left\{ \frac{-6 - \sqrt{57}}{3}, \frac{-6 + \sqrt{57}}{3} \right\}$

6) $2x^2 = 22$

A) $\{-\sqrt{11}, \sqrt{11}\}$

B) $\{12\}$

C) $\{-11, 11\}$

D) $\{11\}$

7) $2x^2 - 10 = 0$

A) $\{-\sqrt{5}, \sqrt{5}\}$

B) $\{-\sqrt{10}, \sqrt{10}\}$

C) $\left\{ -\frac{\sqrt{10}}{2}, \frac{\sqrt{10}}{2} \right\}$

D) $\{\sqrt{5}\}$

8) $x^2 + 14x + 39 = 0$

A) $\{-7 - \sqrt{10}, -7 + \sqrt{10}\}$

C) $\{7 - \sqrt{39}, 7 + \sqrt{39}\}$

B) $\{7 + \sqrt{10}\}$
 D) $\{-14 + \sqrt{39}\}$

9) $5x^2 - 60x + 305 = 0$

A) $\{6 + 5i, 6 - 5i\}$

B) $\{6 - 25i, 6 + 25i\}$

C) $\{6 + 5i\}$

D) $\{11, 1\}$

10) $(4x + 3)^2 = 6$

A) $\left\{ \frac{-3 \pm \sqrt{6}}{4} \right\}$

B) $\left\{ \frac{3 \pm \sqrt{6}}{4} \right\}$

C) $\left\{ \frac{\sqrt{6 \pm 3}}{4} \right\}$

D) $\left\{ \frac{9 \pm \sqrt{6}}{4} \right\}$

11) $(x + 3)(x - 4) = 5$

A) $\left\{ \frac{1 \pm \sqrt{69}}{2} \right\}$

B) $\left\{ \frac{-1 \pm \sqrt{69}}{2} \right\}$

C) $\left\{ \frac{1 \pm i\sqrt{69}}{2} \right\}$

D) $\left\{ \frac{-1 \pm i\sqrt{69}}{2} \right\}$

12) $\frac{x^2}{12} + x + \frac{19}{12} = 0$

A) $\{-6 \pm \sqrt{17}\}$

B) $\{6 \pm \sqrt{17}\}$

C) $\{6 \pm \sqrt{17}\}$

D) $\{-12 \pm \sqrt{19}\}$

13) $-\frac{1}{x+3} + \frac{1}{x} = \frac{1}{7}$

$$A) \left\{ \frac{11 \pm \sqrt{205}}{2} \right\}$$

$$B) \left\{ \frac{-17 \pm \sqrt{205}}{2} \right\}$$

$$C) \left\{ \frac{17 \pm \sqrt{205}}{2} \right\}$$

$$D) \left\{ \frac{-11 \pm \sqrt{205}}{2} \right\}$$

$$\frac{2x^2 - x - 8}{x^2 - 17x + 72}$$

14) $x - 9 - x - 8 =$

A) $\left\{ \frac{7 \pm \sqrt{73}}{2} \right\}$

B) $\left\{ \frac{-7 \pm \sqrt{73}}{2} \right\}$

C) $\frac{7 \pm 5}{2}$

D) $\left\{ \frac{-7 \pm 5}{2} \right\}$

15) $5x^2 - \blacksquare |1| = b$

A) $\left\{ \frac{\sqrt{13 \pm 33}}{10} \right\}$

B) $\left\{ \frac{-\sqrt{13 \pm 33}}{10} \right\}$

C) $\left\{ \frac{\sqrt{13 \pm i7}}{10} \right\}$

D) $\left\{ \frac{\sqrt{13 \pm 189}}{10} \right\}$

Find the x-intercept(s) of the graph of the equation. Graph the equation.

16) $y = x^2 + 3x + 2$

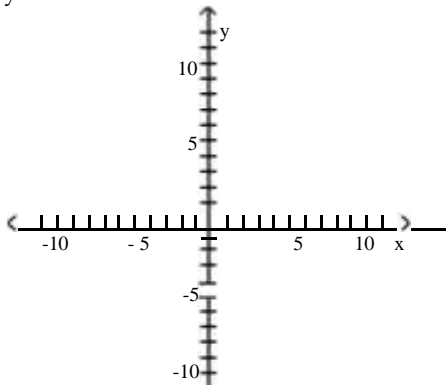

A) x-intercepts: -1 and -2

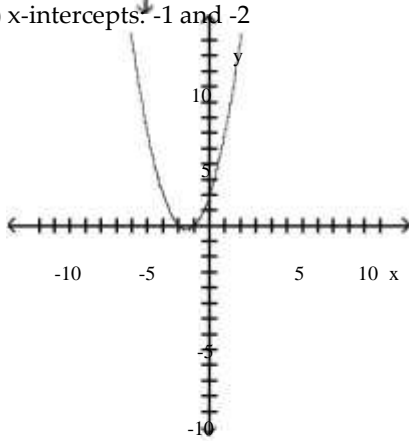

B) x-intercepts: 1 and 2

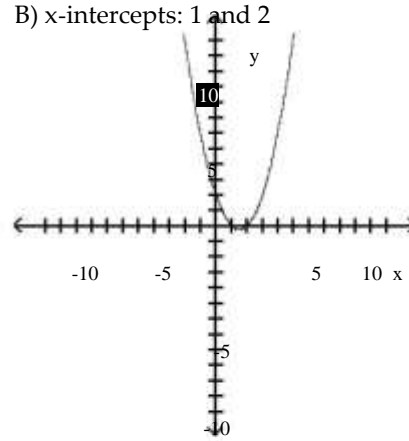

C) x-intercepts: 1 and 2

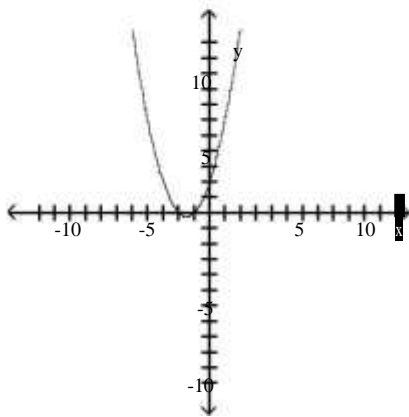

D) x-intercepts: -1 and -2

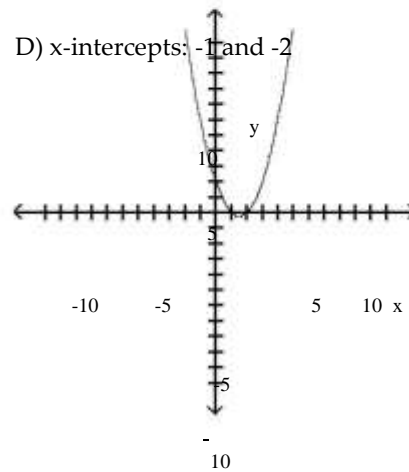

17) $y = x^2 - 12x + 36$

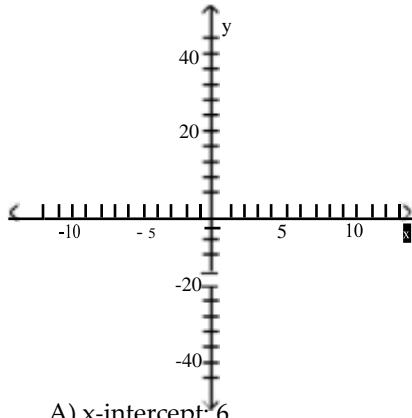

A) x-intercept: 6

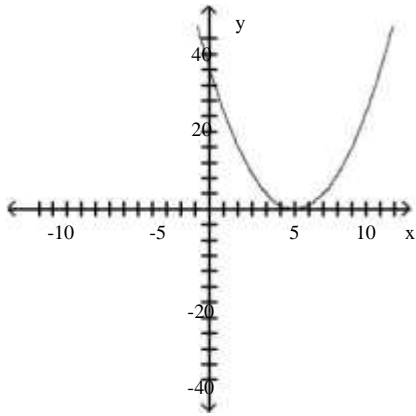

B) x-intercept: -6

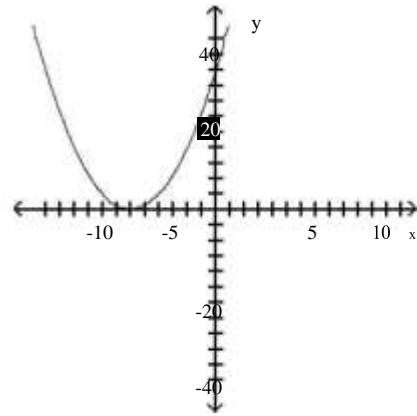

C) x-intercept: 72

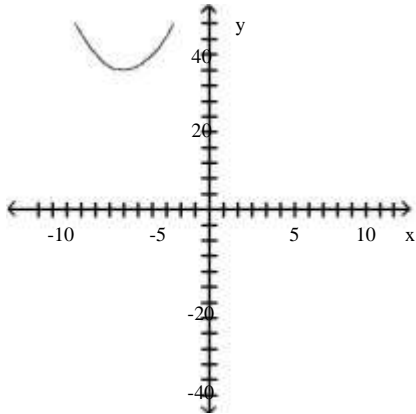

D) x-intercept: none

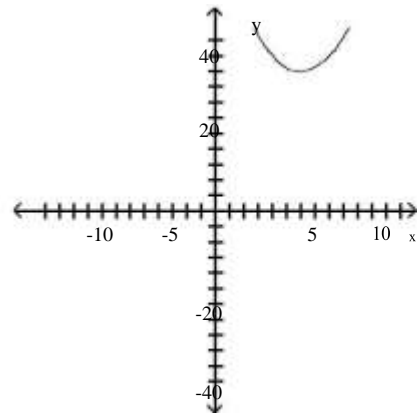

18) $y = x^2 + 4x - 7$

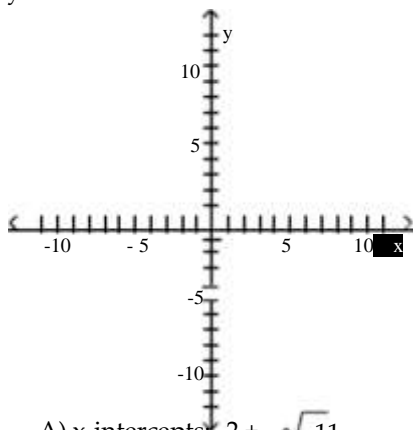

A) x-intercepts: $-2 \pm \sqrt{11}$

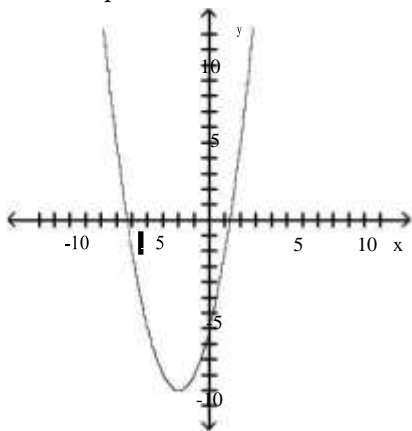

B) x-intercepts: -4 and 3

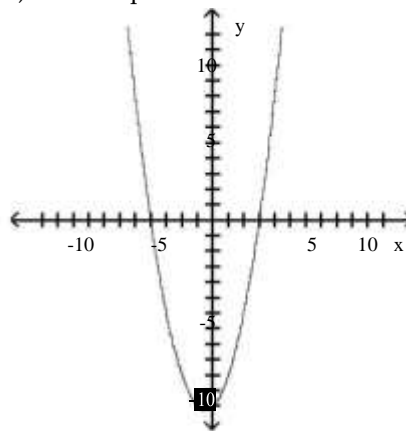

C) x-intercepts: none

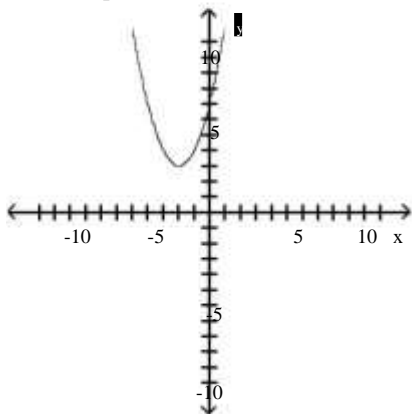

D) x-intercept: 4

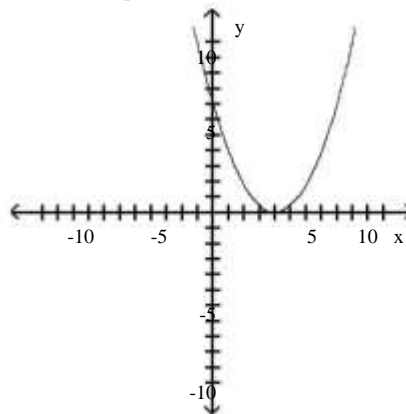

19) $y = x^2 - 5x + 1$

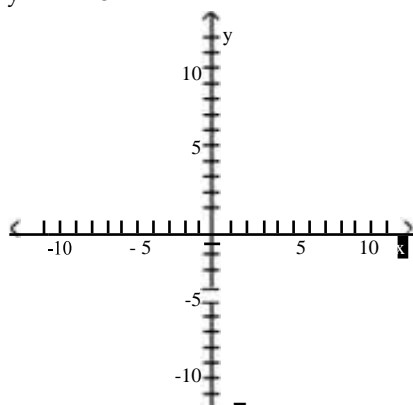

A) x-intercepts: $\frac{5 \pm \sqrt{21}}{2}$

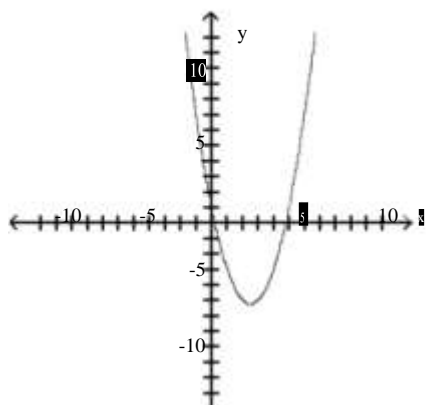

C) x-intercepts: none

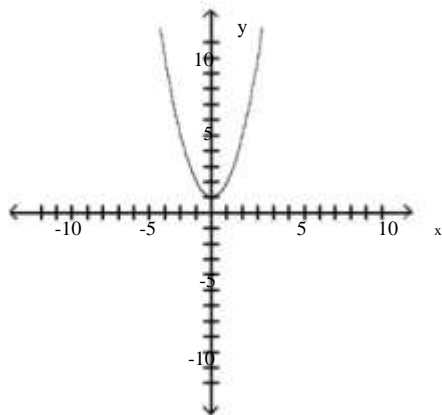

B) x-intercepts: -1 and 5

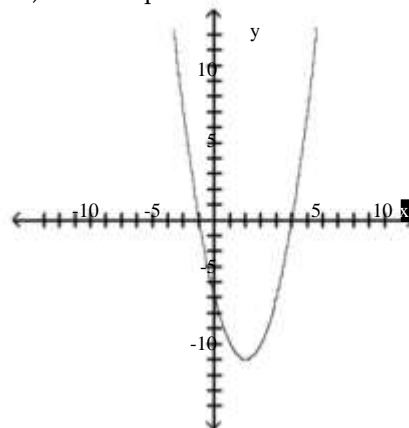

D) x-intercepts: $-5 \pm \sqrt{21}$

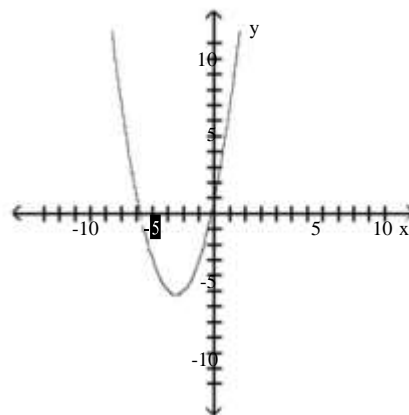

20) $y = -x^2 + 2x + 8$

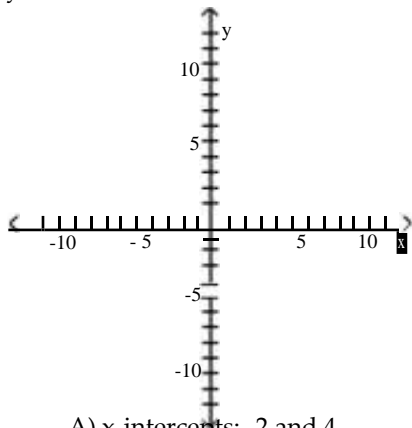

A) x-intercepts: -2 and 4

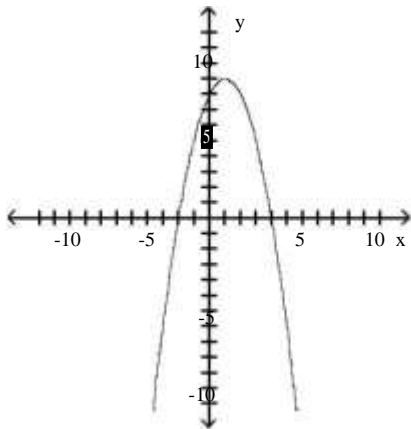

B) x-intercepts: -4 and 2

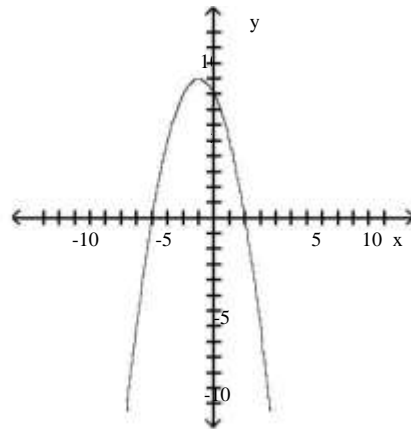

C) x-intercepts: -2 and 4

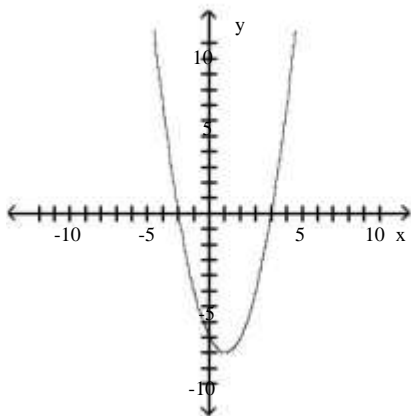

D) x-intercepts: -4 and 2

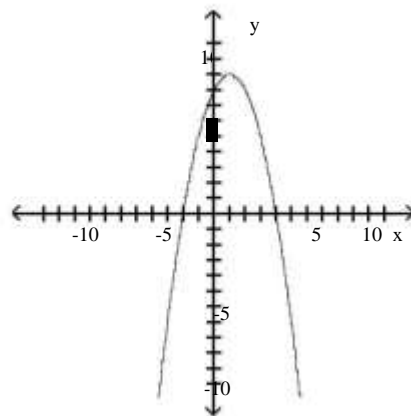

21) $y = 4x^2 - 16x + 21$

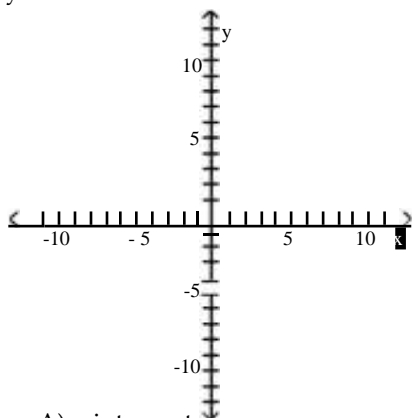

A) x-intercepts: none

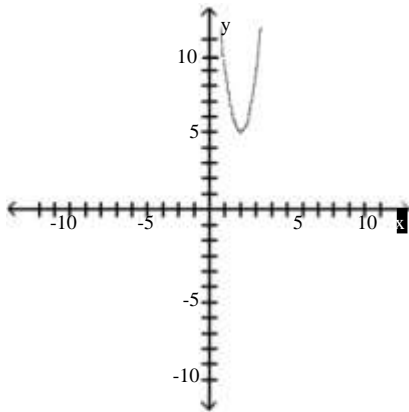

B) x-intercepts: none

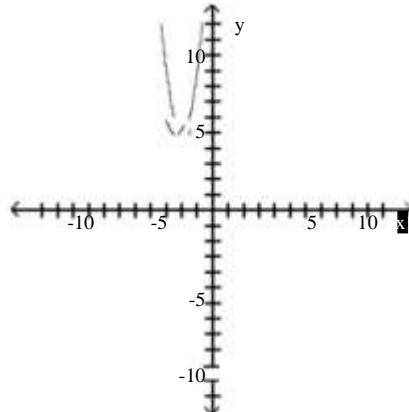

C) x-intercepts: none

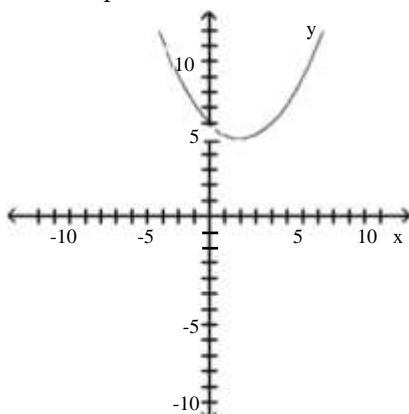

D) x-intercepts: none

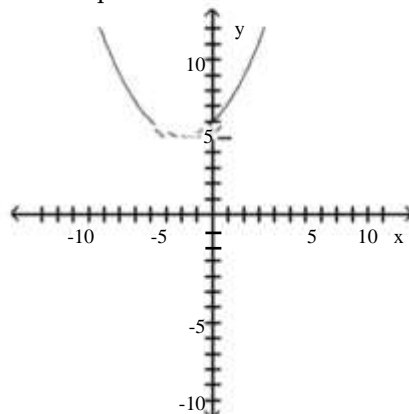

Find all values of x satisfying the given conditions.

22) $y = x^2 + 6x$ and $y = 19$

A) $-3 \pm 2\sqrt{7}$

B) $-3 \pm 2\sqrt{14}$

C) $\pm 2\sqrt{7}$

D) $2\sqrt{7} \pm 3$

23) $y = 4x^2 - 11x - 3$ and $y = 0$

A) $-\frac{1}{4}, 3$

B) $-\frac{1}{4}, 4$

C) $\frac{1}{11}, -\frac{1}{4}$

D) $-4, 3$

24) $y_1 = (x + 5)$, $y_2 = (x - 10)$, and $y_1 y_2 = 8$

A) $\frac{5 \pm \sqrt{257}}{2}$

B) $\frac{-5 \pm \sqrt{257}}{2}$

C) $\frac{5 \pm i\sqrt{257}}{2}$

D) $\frac{-5 \pm i\sqrt{257}}{2}$

25) $y = \frac{1}{x+13}$, $y = \frac{1}{x}$, and $y^2 + y = \frac{1}{2}$

A) $\frac{-9 \pm \sqrt{185}}{2}$

B) $\frac{-17 \pm \sqrt{185}}{2}$

C) $\frac{17 \pm \sqrt{185}}{2}$

D) $\frac{9 \pm \sqrt{185}}{2}$

26) $y_1 = 2 - 10x$, $y_2 = (3x - 7)(x + 1)$, and $y_1 - y_2 = 0$

A) -3, 1

B) -1, $\frac{7}{3}$

C) -1, 3

D) $\frac{1}{5}$

7 Solve Problems Modeled by Quadratic Equations

MULTIPLE CHOICE. Choose the one alternative that best completes the statement or answers the question.

Solve the problem.

- The formula $N = 4x^2 + 5x + 1$ represents the number of households N , in thousands, in a certain city that have a computer x years after 1990. According to the formula, in what year were there 175 thousand households with computers in this city?

A) 1996 B) 1995 C) 1994 D) 1997
- The formula $P = 0.65x^2 - 0.047x + 2$ models the approximate population P , in thousands, for a species of fish in a local pond, x years after 1997. During what year will the population reach 66,530 fish?

A) 2007 B) 2006 C) 2008 D) 2009
- The revenue for a small company is given by the quadratic function $r(t) = 5t^2 + 9t + 630$ where t is the number of years since 1998 and $r(t)$ is in thousands of dollars. If this trend continues, find the year after 1998 in which the company's revenue will be \$746 thousand. Round to the nearest whole year.

A) 2002 B) 2003 C) 2004 D) 2006
- A square sheet of paper measures 40 centimeters on each side. What is the length of the diagonal of this paper?

A) $40\sqrt{2}$ cm B) 40 cm C) 3200 cm D) 80 cm
- A ladder that is 13 feet long is 5 feet from the base of a wall. How far up the wall does the ladder reach?

A) 12 ft B) $\sqrt{194}$ ft C) $2\sqrt{2}$ ft D) 144 ft
- A 16-foot pole is supported by two wires that extend from the top of the pole to points that are each 8 feet from the base of the pole. Find the total length of the two wires.

A) $16\sqrt{5}$ ft B) $8\sqrt{5}$ ft C) 640 ft D) 48 ft
- The length of a rectangular storage room is 4 feet longer than its width. If the area of the room is 60 square feet, find its dimensions.

A) 6 feet by 10 feet

B) 5 feet by 11 feet

C) 7 feet by 11 feet

D) 5 feet by 9 feet

8) A machine produces open boxes using square sheets of plastic. The machine cuts equal-sized squares measuring 2 inches on a side from each corner of the sheet, and then shapes the plastic into an open box by turning up the sides. If each box must have a volume of 242 cubic inches, find the length of one side of the open box.

- A) 11 in. B) 13 in. C) 15 in. D) 10 in.

9) Suppose that an open box is to be made from a square sheet of cardboard by cutting out 2-inch squares from each corner as shown and then folding along the dotted lines. If the box is to have a volume of 98 cubic inches, find the original dimensions of the sheet of cardboard.

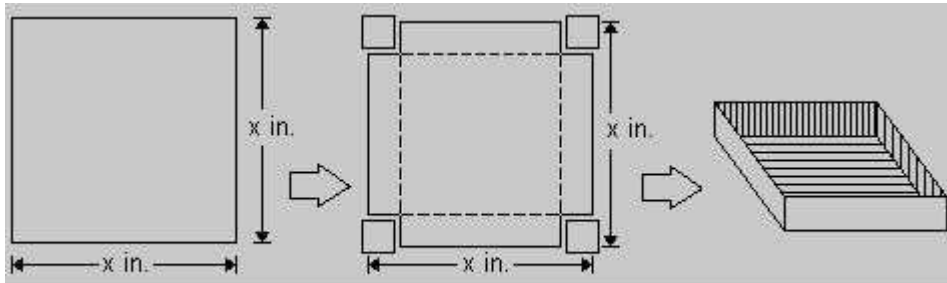

- A) 11 in. by 11 in. B) $7\sqrt{2}$ in. by $7\sqrt{2}$ in. C) $\sqrt{7}$ in. by $\sqrt{14}$ in. D) 7 in. by 7 in.

10) A rain gutter is made from sheets of aluminum that are 27 inches wide. The edges are turned up to form right angles. Determine the depth of the gutter that will allow a cross-sectional area of 49 square inches. There are two solutions to this problem. Round to the nearest tenth of an inch.

- A) 2.2 in. and 11.3 in. B) 2.0 in. and 25.0 in. C) 2.6 in. and 13.6 in. D) 1.6 in. and 20.0 in.

1.6 Other Types of Equations

1 Solve Polynomial Equations by Factoring

MULTIPLE CHOICE. Choose the one alternative that best completes the statement or answers the question.

Solve the polynomial equation by factoring and then using the zero product principle.

1) $3x^4 - 12x^2 = 0$

- A) $\{-2, 0, 2\}$

B) $\{-2\sqrt{3}, 3, 0, \sqrt{2}3\}$

- C) $\{-2, 2\}$

- D) $\{0\}$

2) $2x^4 = 128x$

- A) $\{0, 4\}$

- B) $\{-4, 0, 4\}$

- C) $\{0, 2, 4\}$

- D) $\{0\}$

3) $3x^3 + 4x^2 = 75x + 100$

- A) $\{-5, -\frac{4}{3}, 5\}$

B) $\{-\frac{4}{3}, 0\}$

C) $\{-\frac{4}{3}, 5\}$

- D) $\{-5, 5\}$

4) $5x^3 - 2 = 125x^3 - 50x^2$

- A) $\{\frac{1}{5}, \frac{1}{5}, \frac{2}{5}, -\frac{1}{5}\}$

B) $\{2, -\frac{1}{5}\}$

C) $\{-\frac{1}{25}, \frac{1}{25}, \frac{2}{25}, -\frac{1}{25}\}$

D) $\{\frac{1}{5}, \frac{1}{5}, \frac{5}{2}\}$

5) $x^3 + 9x^2 + 20x = 0$

- A) $\{0, -4, -5\}$

- B) $\{-4, -5\}$

- C) $\{0, 4, 5\}$

- D) $\{4, 5\}$

$$6) x^3 + 5x^2 - x - 5 = 0$$

A) $\{-1, 1, -5\}$

B) $\{1, -5, 5\}$

C) $\{-5, 5\}$

D) $\{25\}$

$$7) 12x^3 + 84x^2 + 120x = 0$$

A) $\{0, -5, -2\}$

B) $\{-5, -2\}$ C) $\{0, 5, 2\}$

D) $\{-1, -2\}$ 5

2 Solve Radical Equations

MULTIPLE CHOICE. Choose the one alternative that best completes the statement or answers the question.

Solve the radical equation, and check all proposed solutions.

1) $x\sqrt{x+2} = 8$ A) $\{62\}$

2) $10x - 9 = 9$ A) $\{9\}$

B) $\{81\}$

$$\sqrt{\quad}$$

B) $\{64\}$

C) $\{66\}$

D) $\{100\}$

C) $\left\{\frac{36}{5}\right\}$

D) \emptyset

3) $\sqrt{9x+36} = x$ A) $\{12\}$

B) $\{-3, 12\}$

C) $\left\{-\frac{9}{2}\right\}$

D) \emptyset

4) $\sqrt{14x-7} = x+3$ A) $\{4\}$

B) $\{-3\}$

C) $\{-4\}$

D) $\{3\}$

5) $x - \sqrt{3x-2} = 4$ A) $\{9\}$

B) $\{2, 9\}$

C) $\{-1\}$

D) $\{1, 2\}$

6) $\sqrt{2x+6} = x+2$ A) $\{8\}$

B) $\{2, 8\}$

C) $\{-4\}$

D) $\left\{4, \frac{4}{3}\right\}$

7) $\sqrt{2x+3} - \sqrt{x+1} = 1$ A) $\{-1, 3\}$

B) $\{3\}$

C) $\{-3, -1\}$

D) \emptyset

8) $\sqrt{2x+5} - \sqrt{x-2} = 3$ A) $\{2, 38\}$

B) $\{3, 8\}$

C) $\{2\}$

D) $\{-2\}$

9) $\sqrt{x+6} + \sqrt{-x} = 4$ A) $\{-2\}$

B) $\{2, -2\}$

C) $\{0\}$

D) $\{3, -2\}$

10) $2x + 3 = \frac{4x - 5}{11 + 69}$

A)

C) $\frac{11}{2}$

11) $\sqrt{1 + 10x} = 1 + x\sqrt{\dots}$

A) {0, 64}

B) $\left\{ \begin{matrix} 0, 4 \\ 9 \end{matrix} \right\}$

B) $\left\{ \frac{11 - \dots}{8}, \frac{11 + \sqrt{69}}{8} \right\}$

D) \emptyset

C) {0, 100}

D) {0, 144}

Find the x-intercepts of the graph of the equation.

12) $y = \sqrt{2x + 3} - \sqrt{x + 1} - 1$

A) 3, -1

B) 3

C) -3, -1

D) No x-intercepts

13) $y = \sqrt{2x + 5} - \sqrt{x - 2} - 3$

A) 2, 38

B) 3, 8

C) 2

D) -2

14) $y = \sqrt{3x - 2} + \sqrt{11 + x} + 1$

A) 0

B) $-\frac{5}{2}$

C) 5

D) No x-intercepts

15) $y = \sqrt{x + 6} + \sqrt{2 - x} - 4$

A) -2

B) 2, -2

C) 0

D) $3\sqrt{-2}$

Find all values of x satisfying the given conditions.

16) $y = x - \dots$ and $y = \dots$

A) 9

B) 2, 9

C) -1

D) 1, 2

SHORT ANSWER. Write the word or phrase that best completes each statement or answers the question.

Solve the problem.

17) Solve the formula $r = \sqrt{\frac{3V}{\pi h}}$ for V.

18) Solve the formula $r = \sqrt{\frac{2A}{\theta}}$ for θ .

MULTIPLE CHOICE. Choose the one alternative that best completes the statement or answers the question.

19) For a culture of 60,000 bacteria of a certain strain, the number of bacteria N that will survive x hours is modeled by the formula $N = 6000 \sqrt{100 - x}$. After how many hours will 18,000 bacteria survive?

A) 91 hours

B) 97 hours

C) 82 hours

D) 9 hours

20) A formula for the length of a diagonal from the upper corner of a box to the opposite lower corner is

$d = \sqrt{L^2 + W^2 + H^2}$, where L, W, and H are the length, width, and height, respectively. Find the length of the diagonal of the box if the length is 23 inches, width is 14 inches, and height is 6 inches. Leave your answer in simplified radical form.

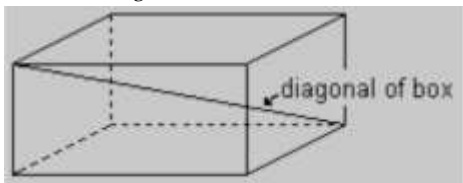

- A) $\sqrt{761}$ inches B) $\sqrt{86}$ inches C) $\sqrt{43}$ inches D) $\sqrt{1522}$ inches

21) A balloon is secured to rope that is staked to the ground. A breeze blows the balloon so that the rope is taut while the balloon is directly above a flag pole that is 100 feet from where the rope is staked down. Find the altitude of the balloon if the rope is 110 feet long.

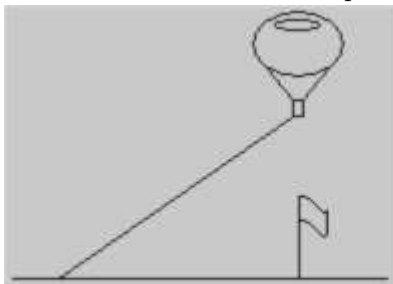

- A) $10\sqrt{21}$ ft B) $\sqrt{210}$ ft C) $10\sqrt{221}$ ft D) $\sqrt{10}$ ft

22) A formula used to determine the velocity v in feet per second of an object (neglecting air resistance) after it has fallen a certain height is $v = \sqrt{2gh}$, where g is the acceleration due to gravity and h is the height the object has fallen. If the acceleration g due to gravity on Earth is approximately 32 feet per second per second, find the velocity of a bowling ball after it has fallen 50 feet. (Round to the nearest tenth.)

- A) 56.6 ft per sec B) 40.0 ft per sec C) 10.0 ft per sec D) 3200 ft per sec

23) For a cone, the formula $r = \sqrt{\frac{3V}{\pi h}}$ describes the relationship between the radius r of the base, the volume V , and the height h . Find the volume if the radius is 4 inches and the cone is 6 inches high. (Use 3.14 as an approximation for π , and round to the nearest tenth.)

- A) 100.5 cubic in. B) 25.1 cubic in. C) 904.3 cubic in. D) 16.7 cubic in.

24) The formula $v = \sqrt{2.5r}$ can be used to estimate the maximum safe velocity v , in miles per hour, at which a car can travel along a curved road with a radius of curvature r , in feet. To the nearest whole number, find the radius of curvature if the maximum safe velocity is 40 miles per hour.

- A) 640 ft B) 4000 ft C) 256 ft D) 1600 ft

25) The function $f(x) = 6.75\sqrt{x} + 12$ models the amount, $f(x)$, in billions of dollars of new student loans x years after 1993. According to the model, in what year is the amount loaned expected to reach \$25.5 billion?

- A) 1997 B) 2000 C) 2002 D) 2001

26) When an object is dropped to the ground from a height of h meters, the time it takes for the object to reach the ground is given by the equation $t = \sqrt{\frac{h}{4.9}}$, where t is measured in seconds. Solve the equation for h .

Use the result to determine the height from which an object was dropped if it hits the ground after falling for 3 seconds.

- A) $h = 4.9t^2$; 44.1 meters B) $h = 24.01t$; 72 meters C) $h = 24.01t^2$; 216.1 meters D) $h = 4.9t$; 14.7 meters

27) The maximum number of volts, E , that can be placed across a resistor is given by the formula $E = \sqrt{PR}$, where P is the number of watts of power that the resistor can absorb and R is the resistance of the resistor in ohms.

Solve this equation for R . Use the result to determine the resistance of a resistor if P is 4 watts and E is 20 volts.

- A) $R = \frac{E^2}{P}$; 1600 ohms B) $R = \frac{E^2}{P^2}$; 6400 ohms
 C) $R = \frac{2}{E P}$; 1600 ohms D) $R = \frac{2}{E P^2}$; 6400 ohms

28) The number of centimeters, d , that a spring is compressed from its natural, uncompressed position is given by the formula $d = \sqrt{\frac{2W}{k}}$, where W is the number of joules of work done to move the spring and k is the spring constant. Solve this equation for W . Use the result to determine the work needed to move a spring 3 centimeters if it has a spring constant of 0.6.

- A) $W = \frac{d^2 k}{2}$; 2.7 joules B) $W = \frac{d^2 k^2}{4}$; 0.8 joules
 C) $W = \frac{2}{k}$; 30 joules D) $W = 2d^2 k$; 10.8 joules

3 Solve Equations with Rational Exponents

MULTIPLE CHOICE. Choose the one alternative that best completes the statement or answers the question.
 Solve and check the equation.

1) $x^{3/2} = 125$

- A) {25} B) {5} C) $\{\sqrt[3]{5}\}$ D) $\{625\}$

2) $4x^{7/2} - 20 = 0$

- A) $\{\sqrt[7]{25}\}$ B) $\{\sqrt[7]{5}\}$ C) $\{\frac{10}{7}\}$ D) \emptyset

3) $(x + 7)^{3/2} = 8$

- A) {-3} B) {-5} C) $\{\sqrt[3]{2-7}\}$ D) {11}

4) $(5x + 2)^{1/2} = 5$

- A) $\{\frac{23}{5}\}$ B) 5 C) $\{-\frac{2}{5}\}$ D) 10

$$5) (5x + 3)^{1/3} = 3$$

A) $\left\{ \frac{24}{5} \right\}$

B) $\left\{ \frac{6}{5} \right\}$

C) $\left\{ \frac{27}{5} \right\}$

D) $\left\{ \frac{22}{3} \right\}$

$$6) (2x - 2)^{1/3} + 2 = 6$$

A) $\{3\}$

B) $\{7\}$

C) $\{9\}$

D) \emptyset

$$7) (x^2 + 14x + 49)^{3/4} - 20 = 7$$

A) $\{-16, 2\}$

B) $\{2\}$

C) $\{-16, 0, 2\}$

D) $\{27\}$

Find all values of x satisfying the given conditions.

$$8) y = (x + 5)^{3/2} \text{ and } y = 343$$

A) $\{44\}$

B) $\{2\}$

C) $\{7 - 5\}$

D) $\{54\}$

4 Solve Equations That Are Quadratic in Form

MULTIPLE CHOICE. Choose the one alternative that best completes the statement or answers the question.

Solve the equation by making an appropriate substitution.

$$1) x^4 - 13x^2 + 36 = 0$$

A) $\{-2, 2, -3, 3\}$

B) $\{4, 9\}$

C) $\{2, 3\}$

D) $\{-2i, 2i, -3i, 3i\}$

$$2) x^4 - 7x^2 + 12 = 0$$

A) $\{-2, 2, -\sqrt{3}, \sqrt{3}\}$

B) $\{-2, 2, -i\sqrt{3}, i\sqrt{3}\}$

C) $\{4, 3\}$

D) $\{2, \sqrt{3}\}$

$$3) x^4 - 23x^2 - 50 = 0$$

A) $\{-5, 5, -i\sqrt{2}, i\sqrt{2}\}$

B) $\{-\sqrt{2}, \sqrt{2}, -5i, 5i\}$

C) $\{-25, 2\}$

D) $\{5, i\sqrt{2}\}$

$$4) x - 4\sqrt{x} - 32 = 0$$

A) $\{64\}$

B) $\{32\}$

C) $\{128\}$

D) $\{48\}$

$$5) x - 9\sqrt{x} + 14 = 0$$

A) $\{49, 4\}$

B) $\{7, 2\}$

C) $\{-7, 7, -2, 2\}$

D) $\{-\sqrt{7}, \sqrt{7}, -2, \sqrt{2}\}$

$$6) 2x - 9\sqrt{x} - 5 = 0$$

A) $\{25\}$

B) $\{5\}$

C) $\left\{ \frac{1}{4}, 25 \right\}$

D) $\left\{ \frac{1}{2}, 5 \right\}$

$$7) x^{-2} + x^{-1} - 12 = 0$$

A) $\left\{ -\frac{1}{4}, \frac{1}{3} \right\}$

B) $\left\{ \frac{1}{4}, -\frac{1}{3} \right\}$

C) $\{4, -3\}$

D) $\{-4, 3\}$

$$8) x^{-2} + 3x^{-1} + 2 = 0$$

$$A) \left\{ \frac{1}{4}, -\frac{1}{2} \right\}$$

$$B) \left\{ \frac{1}{2}, 1 \right\}$$

$$C) \{1, 2\}$$

$$D) \{-1, -2\}$$

$$9) 4x^{-2} - 5x^{-1} + 1 = 0$$

$$A) \{1, 4\}$$

$$B) \left\{ -\frac{1}{4}, -1 \right\}$$

$$C) \{-1, -4\}$$

$$D) \left\{ \frac{1}{4}, 1 \right\}$$

$$10) x^{-2} - 8x^{-1} + 10 = 0$$

$$A) \left\{ \frac{4 \pm \sqrt{6}}{10} \right\}$$

$$B) \left\{ \frac{4 \pm 2\sqrt{6}}{10} \right\}$$

$$C) \left\{ \frac{-4 \pm \sqrt{6}}{10} \right\}$$

$$D) \left\{ \frac{4 \pm \sqrt{6}}{22} \right\}$$

$$11) x - 16x^{1/2} - 512 = 0$$

$$A) \{1024\}$$

$$B) \{512\}$$

$$C) \{2048\}$$

$$D) \{768\}$$

$$12) x^{2/3} - 8x^{1/3} + 15 = 0$$

$$A) \{27, 125\}$$

$$B) \{3, 5\}$$

$$C) \{-5, -3\}$$

$$D) \{-125, -27\}$$

$$13) x^{2/5} - x^{1/5} - 12 = 0$$

$$A) \{1024, -243\}$$

$$B) \{-1024, 243\}$$

$$C) \{4, -3\}$$

$$D) \{-4, 3\}$$

$$14) 2x^{1/2} - 15x^{1/4} - 27 = 0$$

$$A) \{6561\}$$

$$B) \left\{ 6561, -\frac{81}{16} \right\}$$

$$C) \{-9, -3\}$$

$$D) \left\{ 9, -\frac{3}{2} \right\}$$

$$15) x^{1/2} - 15x^{1/4} + 54 = 0$$

$$A) \{1296, 6561\}$$

$$B) \{36, 81\}$$

$$C) \{-6, -9\}$$

$$D) \{6, 9\}$$

$$16) (x+5)^2 - 4(x+5) + 3 = 0$$

$$A) \{-4, -2\}$$

$$B) \{6, 8\}$$

$$C) \{-8, -6\}$$

$$D) \{2, 4\}$$

$$17) (4x+9)^2 + 5(4x+9) + 4 = 0$$

$$A) \left\{ \frac{1}{3}, -\frac{1}{4} \right\}$$

$$B) \left\{ \frac{1}{4}, -\frac{1}{2} \right\}$$

$$C) \{-4, -1\}$$

$$D) \left\{ \frac{1}{4}, -\frac{1}{2} \right\}$$

$$18) (4x-3)^2 - 10(4x-3) + 24 = 0$$

$$A) \left\{ \frac{7}{4}, \frac{9}{4} \right\}$$

$$B) \left\{ \frac{7}{4}, -\frac{9}{4} \right\}$$

$$C) \left\{ \frac{1}{4}, -\frac{3}{4} \right\}$$

$$D) \left\{ \frac{3}{3}, -\frac{1}{4} \right\}$$

$$19) (x^2 - 4x)^2 - 17(x^2 - 4x) + 60 = 0$$

$$A) \{-1, -2, 5, 6\}$$

$$B) \{5, 12\}$$

$$C) \left\{ \frac{5}{12}, \frac{6}{2} \right\}$$

$$D) \{-1, -2, 5, 12, 5, 6\}$$

$$20) \left(y - \frac{12}{y} \right)^2 - \left(3y - \frac{12}{y} \right) - 4 = 0$$

$$A) \{-4, -2, 3, 6\}$$

$$B) \{-1, 4\}$$

$$C) \{-4, 3\}$$

$$D) \text{no solution}$$

Match the graph with its function using the x -intercepts.

21)

12

8

4

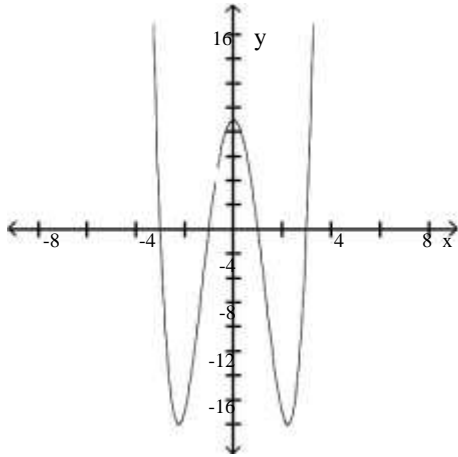

A) $y = x^4 - 10x^2 + 9$

B) $y = x^4 + 10x^2 + 9$

C) $y = x^4 - 10x^2 - 9$

D) $y = x^4 + 10x^2 - 9$

22)

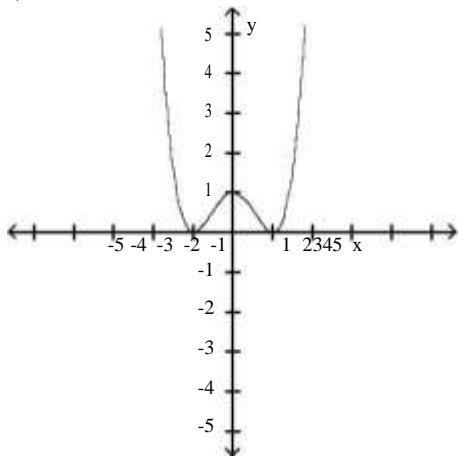

A) $y = x^4 - 2x^2 + 1$

B) $y = x^4 + 2x^2 + 1$

C) $y = x^4 - 2x^2 - 1$

D) $y = x^4 + 2x^2 - 1$

23)

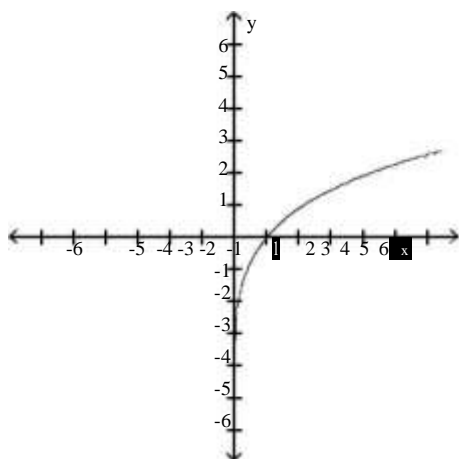

A) $y = x^{1/3} + 5x^{1/6} - 6$

C) $y = x^{1/3} + 5x^{1/6} + 6$

B) $y = x^{1/3} - 5x^{1/6} - 6$

D) $y = x^{1/3} - 5x^{1/6} + 6$

24)

6

4

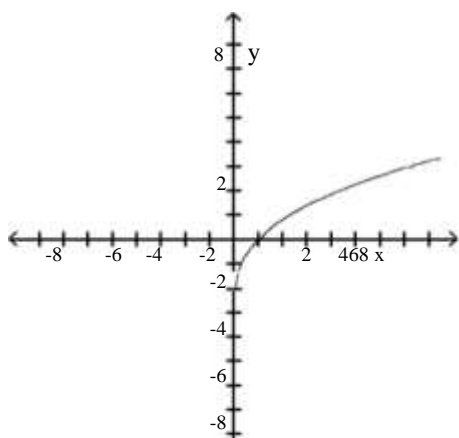

A) $y = x^{1/2} + 2x^{1/4} - 3$

C) $y = x^{1/2} + 2x^{1/4} + 1$

B) $y = x^{1/2} - 2x^{1/4} - 3$

D) $y = x^{1/2} + 2x^{1/4} - 1$

25)

4

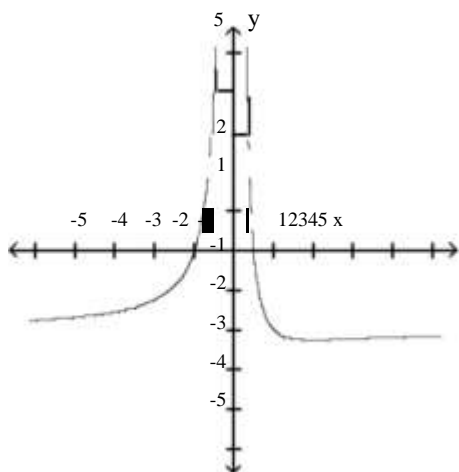

A) $y = x^{-2} - x^{-1} - 2$

B) $y = x^{-2} - x^{-1} + 2$

C) $y = x^{-2} + x^{-1} - 2$

D) $y = x^{-2} + x^{-1} + 2$

26)

4
3
2
1

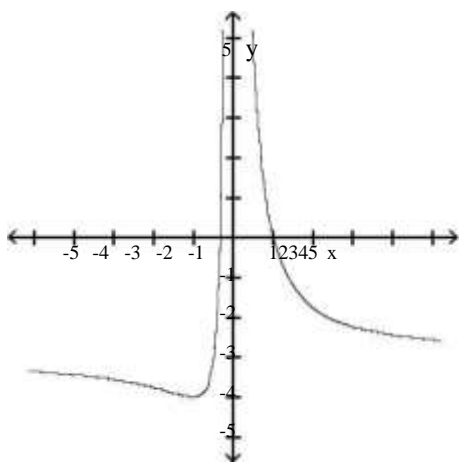

A) $y = x^{-2} + 2x^{-1} - 3$

B) $y = x^{-2} - 2x^{-1} - 3$

C) $y = x^{-2} + 2x^{-1} + 3$

D) $y = x^{-2} - 2x^{-1} + 3$

27)

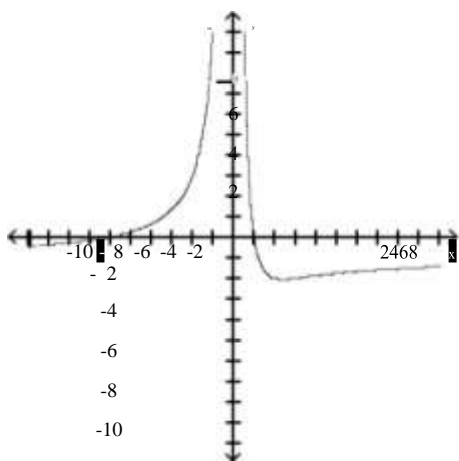

A) $y = 6x^{-2} - 5x^{-1} - 1$

B) $y = 6x^{-2} + 5x^{-1} - 1$

C) $y = 6x^{-2} - 5x^{-1} + 1$

D) $y = 6x^{-2} + 5x^{-1} + 1$

28)

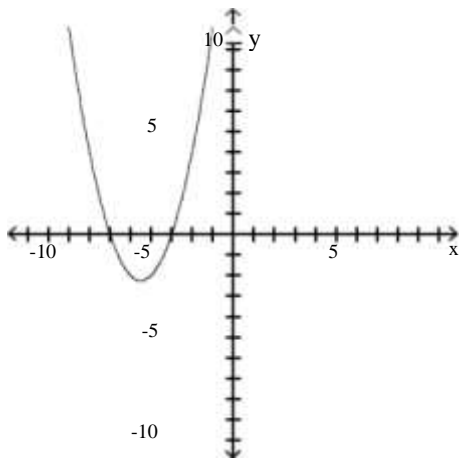

A) $y = (x + 5)^2 - 1(x + 5) - 2$

B) $y = (x + 5)^2 + 1(x + 5) - 2$

C) $y = (x + 5)^2 + 9(x + 5) + 18$

D) $y = (x + 5)^2 - 9(x + 5) + 18$

29)29)

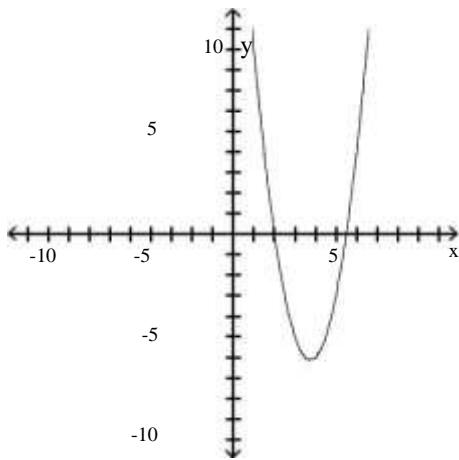

A) $y = 2(x - 3)^2 - 3(x - 3) - 5$

B) $y = 2(x - 3)^2 + 3(x - 3) - 5$

C) $y = 2(x + 3)^2 - 3(x + 3) - 5$

D) $y = 2(x + 3)^2 + 3(x + 3) - 5$

30)30)

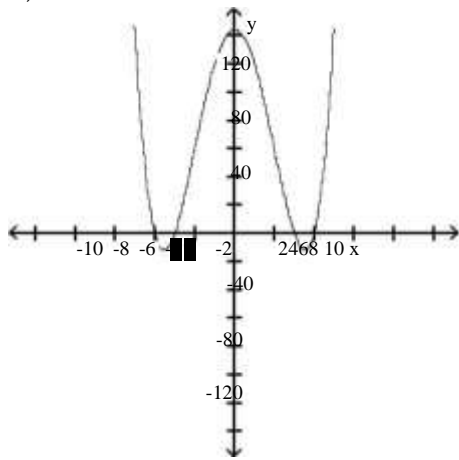

A) $y = x^4 - 25x^2 + 144$

C) $y = x^4 - 25x^2 + 12$

B) $y = x^4 + 25x^2 + 144$

D) $y = x^4 + 25x^2 - 12$

Find all values of x satisfying the given conditions.

31) $y = (x^2 - 2x)^2 - 11(x^2 - 2x)$ and $y = -24$

A) -1, -2, 3, 4

B) 3, 8

C) 3, 4

D) -1, -2, 3, 8, 3, 4

32) $y = \left(x - \frac{15}{x}\right)^2 - 12\left(x - \frac{15}{x}\right)$ and $y = 28$

A) -5, -1, 3, 15

B) -2, 14

C) -5, 3

D) No solution

33) $y = x^{2/3} - 6x^{1/3}$ and $y = -5$

A) 1, 125

B) 1, 5

C) -5, -1

D) -125, -1

34) $y = 5(6x - 1)^{-1/2}$, $y = 2(6x - 1)^{-2}$, and y exceeds y by 2

A) $-\frac{1}{2}, \frac{1}{4}$

B) $-\frac{1}{2}, -\frac{1}{4}$

C) $-\frac{1}{6}, 0$

D) $-\frac{1}{6}, -\frac{1}{12}$

35) $y^1 = \frac{x}{x-6} + 8$, $y^2 = 6\sqrt{\frac{x}{x-6}}$, and $y^1 = y^2$

A) 8, $\frac{32}{5}$

B) 2, 4

C) 12, 8

D) -8, $-\frac{32}{5}$

5 Solve Equations Involving Absolute Value

MULTIPLE CHOICE. Choose the one alternative that best completes the statement or answers the question.

Solve the absolute value equation or indicate that the equation has no solution.

1) $|x| = 11$

A) $\{-11, 11\}$

B) $\{11\}$

C) $\{-11\}$

D) $\{121\}$

2) $|x - 2| = 9$

A) $\{-7, 11\}$

B) $\{7, 11\}$

Page 69

C) $\{-11\}$

D) \emptyset

3) $|x + 6| = 2$

A) $\{-8, -4\}$

B) $\{4, -8\}$

C) $\{-4\}$

D) \emptyset

4) $7|x + 8| = 5$

A) $\left\{ \frac{3}{7}, -\frac{13}{7} \right\}$

B) $\left\{ -\frac{3}{8}, -\frac{13}{8} \right\}$

C) $\left\{ \frac{3}{7}, \frac{13}{7} \right\}$

D) \emptyset

5) $3|x - 3| = 18$

A) $\{9, -3\}$

B) $\{3, -9\}$

C) $\{3\}$

D) \emptyset

6) $8|x + 9| + 5 = 9$

A) $\left\{ \frac{13}{8}, -\frac{5}{8} \right\}$

B) $\left\{ -\frac{13}{9}, -\frac{5}{9} \right\}$

C) $\left\{ \frac{5}{8}, \frac{13}{8} \right\}$

D) \emptyset

7) $5|x + 5| + 2 = -2$

A) $\left\{ \frac{9}{5}, \frac{1}{5} \right\}$

B) $\left\{ -\frac{9}{5} \right\}$

C) $\left\{ -\frac{1}{5}, \frac{9}{5} \right\}$

D) \emptyset

8) $|2x + 2| = |x + 2|$

A) $\{0, -3\}$

B) $\left\{ \frac{2}{3}, 0 \right\}$

C) $\left\{ 0, \frac{4}{3} \right\}$

D) \emptyset

9) $\left| \frac{1}{2}x + 2 \right| = \left| \frac{3}{4}x - 2 \right|$

A) $\{16, 0\}$

B) $\{16, 12\}$

C) $\{10, 10\}$

D) \emptyset

10) $\left| \frac{9x}{2} + 18 \right| = 9$

A) $\{-4, 0\}$

B) $\{-4, 4\}$

C) $\{4, 0\}$

D) \emptyset

11) $|2(x+1) + 4| = 12$
(C) $\frac{1}{3}$ 33
 A) $\{-9, 3\}$

B) $\{-7, 5\}$

C) $\{-9, 0\}$

D) \emptyset

12) $|x^2 + 3x| = 0$
 A) $\{0, -3\}$

B) $\{3, 0, -3\}$

C) $\{3, 0\}$

13) $x^2 - 4x - 4 = 8$
 A) $\{-2, 2, 6\}$

B) $\{2, 6\}$

C) $\{-2, 2\}$

14) $|2x^2 - x - 1| = 3$

A) $\left\{ -\frac{1}{4}, \frac{1}{4}, \frac{1 + \sqrt{33}}{4}, \frac{1 - \sqrt{33}}{4} \right\}$

B) $\left\{ -\frac{1 - \sqrt{33}}{4}, -\frac{1 + \sqrt{33}}{4} \right\}$

D)
{
7,
0}

D)
 \emptyset

D
)
{
2,
2,
-
6}

$$15) \left| x^2 - 4x + 4 \right| = 2$$

A) $\{2 - \sqrt{2}, 2\}$

B) $\{2 - \sqrt{2}\}$

C) $\{2 + \sqrt{2}\}$

D) \emptyset

Find all values of x satisfying the given conditions.

16) $y = |x - 7|$ and $y = 9$

A) $-2, 16$

B) $-16, 2$

C) 16

D) No solutions

17) $y = |3x + 4|$ and $y = 2$

A) $-\frac{2}{3}, -2$

B) $-\frac{1}{2}, -\frac{3}{2}$

C) 2

D) No solutions

1.7 Linear Inequalities and Absolute Value Inequalities

1 Use Interval Notation

MULTIPLE CHOICE. Choose the one alternative that best completes the statement or answers the question.

Express the interval in set-builder notation and graph the interval on a number line.

1) $(-2, 7]$

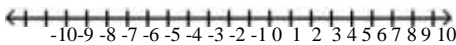

A) $\{x \mid -2 < x \leq 7\}$

B) $\{x \mid -2 < x < 7\}$

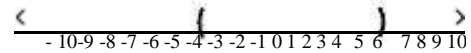
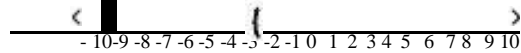

C) $\{x \mid x \leq 7\}$

D) $\{x \mid -2 \leq x \leq 7\}$

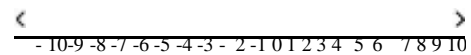
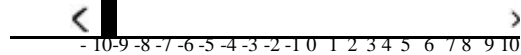

2) $[-2, 1)$

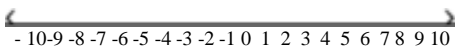

A) $\{x \mid -2 \leq x < 1\}$

B) $\{x \mid -2 < x \leq 1\}$

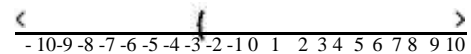
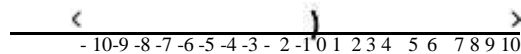

C) $\{x \mid x < 1\}$

D) $\{x \mid -2 \leq x \leq 1\}$

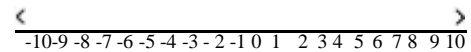
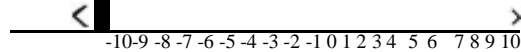

3) $-\infty, 7.5$

-10 -9 -8 -7 -6 -5 -4 -3 -2 -1 0 1 2 3 4 5 6 7 8 9 10

A) $\left\{ x \mid x < \frac{7}{5} \right\}$

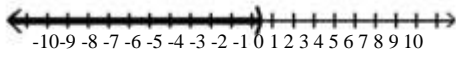

C) $\left\{ x \mid x \leq \frac{7}{5} \right\}$

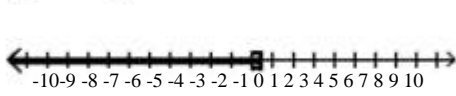

B) $\left\{ x \mid x > \frac{7}{5} \right\}$

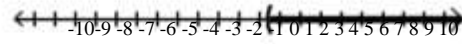

D) $\{x \mid 5 \leq x \leq 7\}$

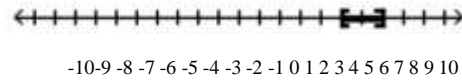

4) $[-1, 9]$

-10 -9 -8 -7 -6 -5 -4 -3 -2 -1 0 1 2 3 4 5 6 7 8 9 10

A) $\{x \mid -1 \leq x \leq 9\}$

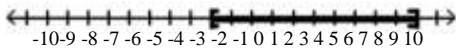

C) $\{x \mid -1 < x < 9\}$

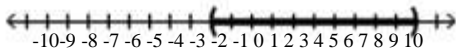

B) $\{x \mid -1 < x \leq 9\}$

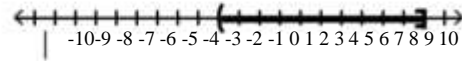

D) $\{x \mid -1 \leq x < 9\}$

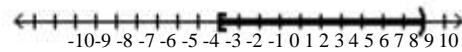

5) $(-4, \infty)$

-10 -9 -8 -7 -6 -5 -4 -3 -2 -1 0 1 2 3 4 5 6 7 8 9 10

A) $\{x \mid x > -4\}$

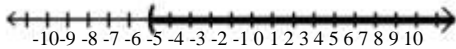

C) $\{x \mid x > -4\}$

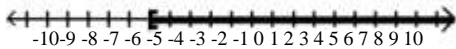

B) $\{x \mid x \geq -4\}$

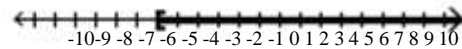

D) $\{x \mid x \geq -4\}$

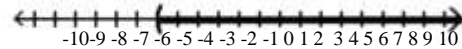

6) $[-2, \infty)$

-10 -9 -8 -7 -6 -5 -4 -3 -2 -1 0 1 2 3 4 5 6 7 8 9 10

A) $\{x \mid x \geq -2\}$

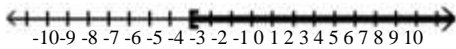

C) $\{x \mid x > -2\}$

B) $\{x \mid x > -2\}$

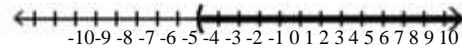

D) $\{x \mid x \geq -2\}$

~~←10 9 8 7 6 5 4 3 2 1 0 1 2 3 4 5~~ 6 7 8 9 10,

-10 -9 -8 -7 -6 -5 -4 -3 -2 -1 0 1 2 3 4 5 6 7 8 9 10



7) $(-\infty, 7.5]$

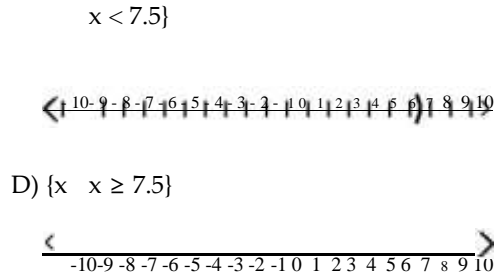
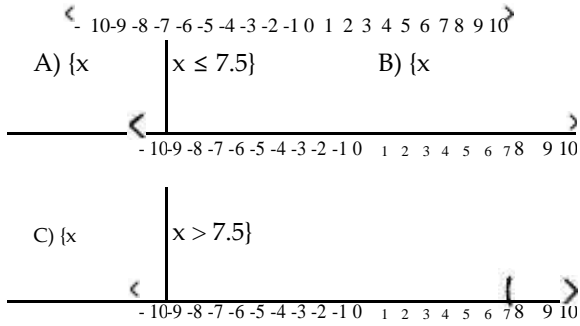

2 Find Intersections and Unions of Intervals

MULTIPLE CHOICE. Choose the one alternative that best completes the statement or answers the question.

Use graphs to find the set.

1) $(-9, 0) \cap [-4, 6]$

A) $[-4, 0)$

B) $(-9, 6]$

C) $(0, 6]$

D) $(-9, -4]$

2) $(-9, 0) \cup [-4, 10]$

A) $(-9, 10]$

B) $[-4, 0)$

C) $(0, 10]$

D) $(-9, -4]$

3) $(-\infty, 7) \cap [-3, 16]$

A) $[-3, 7)$

B) $(-\infty, 16)$

C) $(7, 16)$

D) $(-\infty, -3]$

4) $(-\infty, 3) \cup [-9, 19]$

A) $(-\infty, 19)$

B) $[-9, 3)$

C) $(3, 19)$

D) $(-\infty, -9]$

5) $(1, \infty) \cap [13, \infty)$

A) $[13, \infty)$

B) $(1, \infty)$

C) $(1, 13]$

D) $(-\infty, \infty)$

6) $(4, \infty) \cup [12, \infty)$

A) $(4, \infty)$

B) $[12, \infty)$

C) $(4, 12]$

D) $(-\infty, \infty)$

3 Solve Linear Inequalities

MULTIPLE CHOICE. Choose the one alternative that best completes the statement or answers the question.

Solve the linear inequality. Other than \emptyset , use interval notation to express the solution set and graph the solution set on a number line.

1) $4x + 8 < 36$

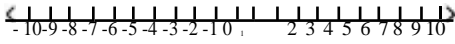

A) $(-\infty, 7)$

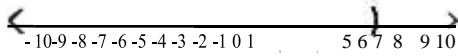

C) $[7, \infty)$

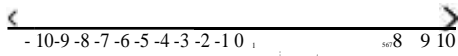

B) $(7, \infty)$

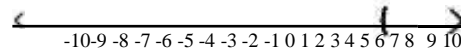

D) $(-\infty, 7]$

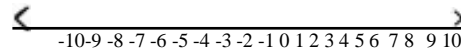

2) $-8x \geq 24$

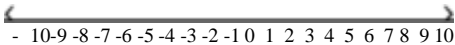

A) $(-\infty, -3]$

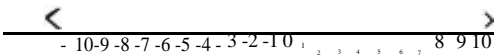

C) $[3, \infty)$

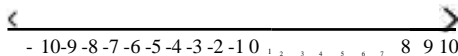

B) $[-3, \infty)$

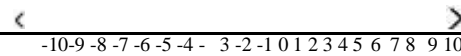

D) $(-\infty, 3]$

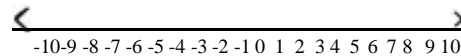

3) $4x - 1 > 3x + 5$



A) $(6, \infty)$



B) $(-\infty, 6]$

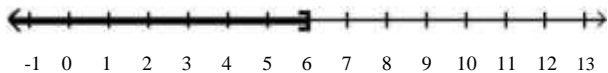

C) $(4, \infty)$

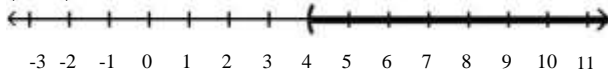

D) $[6, \infty)$



4) $6x - 7 \geq 5x - 8$



A) $[-1, \infty)$

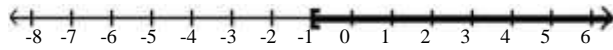

B) $(-\infty, -1)$



C) $(-\infty, -1]$



D) $(-15, \infty)$

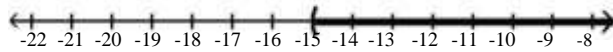

5) $21x - 21 > 3(6x - 2)$



A) $(5, \infty)$



B) $[5, \infty)$



C) $(-\infty, 5)$



D) $(-9, \infty)$



6) $-2(3x + 7) < -8x - 2$



A) $(-\infty, 6)$



B) $(6, \infty)$



C) $(-\infty, 6]$



D) $(-\infty, 8]$



7) $-35x - 20 \leq -5(6x - 3)$



A) $[-7, \infty)$



B) $(-\infty, -7]$



C) $(-7, \infty)$

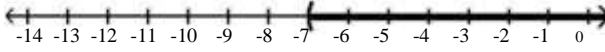

D) $(-\infty, -7)$



8) $35x - 25 \leq 5(6x - 8)$



A) $(-\infty, -3]$

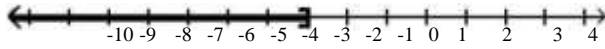

B) $[-3, \infty)$

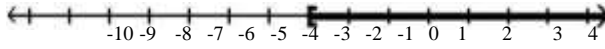

C) $(-\infty, -3)$

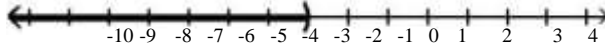

D) $[-\infty, -13)$

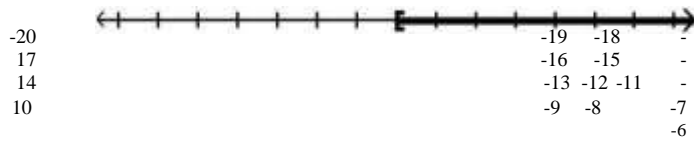

9) $\frac{x}{5} - \frac{1}{6} \leq \frac{x}{4} + 1$

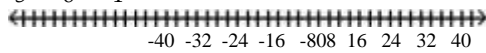

A) $[-70, \infty)$

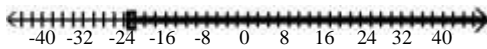

C) $(-70, \infty)$

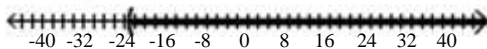

10) $\frac{x}{18} - 2 \geq \frac{x}{24} - 3 + 1$

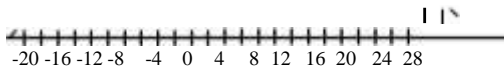

A) $[0, \infty)$

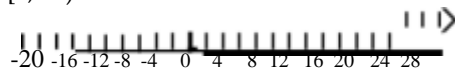

C) $(0, \infty)$



$$B) \left[-\infty, -\frac{70}{3} \right]$$

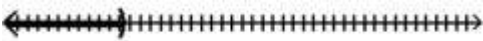
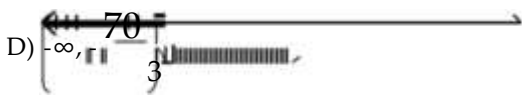
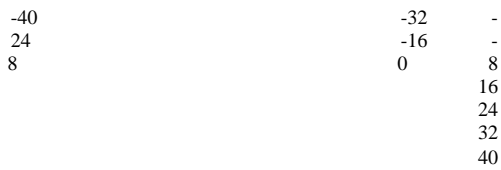

B) $(-\infty, 0]$

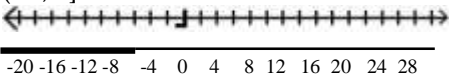

D) $(-\infty, 0)$

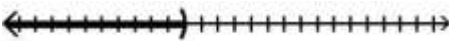

-20 -16 -12 -8 -4 0 4 8 12 16 20 24 28

Use interval notation to represent all values of x satisfying the given conditions.

11) $y_1 = 7x + 5$, $y_2 = 6x + 11$, and $y_1 > y_2$.

- A) $(6, \infty)$ B) $(-\infty, 6]$ C) $(16, \infty)$ D) $[6, \infty)$

12) $y_1 = 8x + 7$, $y_2 = 7x + 4$, and $y_1 \leq y_2$.

- A) $(-\infty, -3]$ B) $(-\infty, -3)$ C) $[-3, \infty)$ D) $[11, \infty)$

13) $y_1 = 3^{-x}$, $y_2 = 5 + 18^{-x}$, and $y_1 \geq y_2$.

- A) $[18, \infty)$ B) $[-18, \infty)$ C) $(-\infty, 18]$ D) $(18, \infty)$

14) $y = 5 - 3(1 - x)$ and y is at most -22 .

- A) $(-\infty, -8]$ B) $[-8, \infty)$ C) $(-\infty, -7]$ D) $(-\infty, -8)$

15) $y = \frac{x-4}{16} - \frac{x-3}{20} - \frac{1}{80}$ and y is at least 0 .

- A) $[9, \infty)$ B) $(-\infty, 9]$ C) $(9, \infty)$ D) $(-\infty, 9)$

Solve the problem.

16) When making a long distance call from a certain pay phone, the first three minutes of a call cost \$1.60. After that, each additional minute or portion of a minute of that call costs \$0.15. Use an inequality to find the number of minutes one can call long distance for \$2.95.

- A) 12 minutes or fewer B) 9 minutes or fewer
C) 2 minutes or fewer D) 20 minutes or fewer

17) It takes 14 minutes to set up a candy making machine. Once the machine is set up, it produces 20 candies per minute. Use an inequality to find the number of candies that can be produced in 6 hours if the machine has not yet been set up.

- A) 6920 candies or fewer B) 120 candies or fewer
C) 4760 candies or fewer D) 1680 candies or fewer

18) A certain store has a fax machine available for use by its customers. The store charges \$2.50 to send the first page and \$0.45 for each subsequent page. Use an inequality to find the number of pages that can be faxed for \$6.10.

- A) 9 pages or fewer B) 58 pages or fewer C) 2 pages or fewer D) 14 pages or fewer

19) Claire has received scores of 85, 88, 87, and 85 on her algebra tests. What score must she receive on the fifth test to have an overall test score average of at least 88?

- A) 95 or greater B) 96 or greater C) 94 or greater D) 93 or greater

20) Using data from 1996 -1998, the annual number of cars sold at a certain dealership can be modeled by the formula

$$y = 2x + 4,$$

where y is the number of cars, in thousands, sold x years after 1996. According to this formula, in which years will the number of cars sold exceed 24 thousand?

- A) Years after 2006 B) Years after 2004 C) Years after 2008 D) Years after 2010

21) ABC phone company charges \$16 per month plus 4¢ per minute of phone calls. XYZ phone company charges \$10 per month plus 6¢ per minute of phone calls. How many minutes of phone calls in a month make XYZ phone company the better deal?

- A) Less than 300 minutes B) More than 300 minutes
C) More than 30 minutes D) Less than 30 minutes

22) Greg is opening a car wash. He estimates his cost equation as $C = 8000 + 0.08x$ and his revenue equation as $R = 1.6x$, where x is the number of cars washed in a six -month period. Find the number of cars that must be washed in a six-month period for Greg to make a profit.

- A) At least 5264 cars B) At least 527 cars C) At least 52,632 cars D) At least 4264 cars

23) A standard train ticket in a certain city costs \$2.00 per ride. People who use the train also have the option of purchasing a frequent-rider pass for \$17.25 each month. With the pass, a ticket costs only \$1.25 per ride. How many train rides in a month make the frequent -rider pass a better deal than standard train tickets?

- A) 24 or more rides B) 23 or more rides C) 22 or more rides D) 25 or more rides

24) Every Sunday, Jarod buys a loaf of fresh bread for his family from the corner bakery for \$3.00. The local department store has a sale on breadmakers for \$73. If the bread-making supplies cost \$0.71 per week, for how many weeks would Jarod have to bake a loaf of bread at home before the breadmaker starts saving him money?

- A) At least 32 weeks B) At least 31 weeks C) At least 34 weeks D) At least 33 weeks

4 Recognize Inequalities with No Solution or All Real Numbers as Solutions

MULTIPLE CHOICE. Choose the one alternative that best completes the statement or answers the question.

Solve the linear inequality. Other than \emptyset , use interval notation to express the solution set and graph the solution set on a number line.

1) $5(4x + 7) - 4x < 4(8 + 4x) - 6$

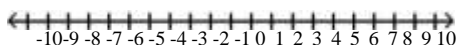

- A) \emptyset B) $(-\infty, \infty)$

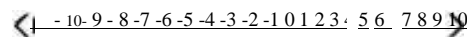
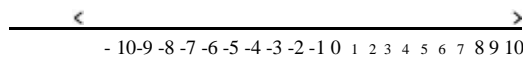

- C) $(-\infty, 7)$ D) $(7, \infty)$



2) $6(x + 4) \geq 5(x - 3) + x$

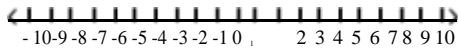

A) $(-\infty, \infty)$

B) \emptyset

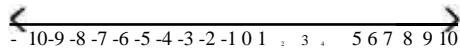

C) $(-\infty, 5]$

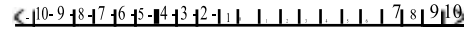

D) $[5, \infty)$

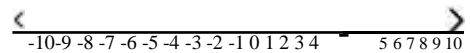
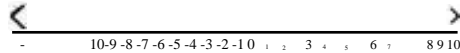

3) $-2x \leq -2(x - 7)$

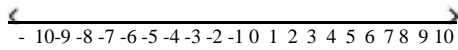

A) $(-\infty, \infty)$

B) \emptyset

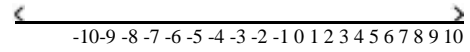
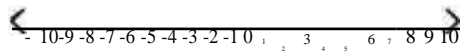

C) $(-\infty, -7]$

D) $[-7, \infty)$

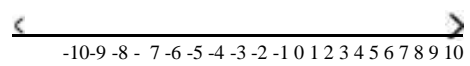
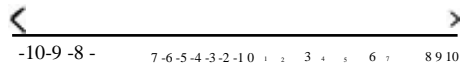

5 Solve Compound Inequalities

MULTIPLE CHOICE. Choose the one alternative that best completes the statement or answers the question.

Solve the compound inequality. Other than \emptyset , use interval notation to express the solution set and graph the solution set on a number line.

1) $20 < 5x \leq 35$

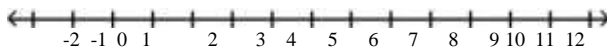

A) $(4, 7]$

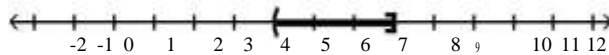

B) $[4, 7)$

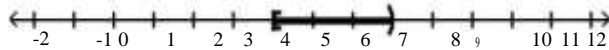

C) $(-\infty, 4) \cup [7, \infty)$

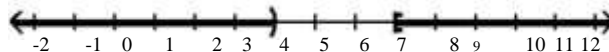

D) $(-\infty, 4] \cup (7, \infty)$

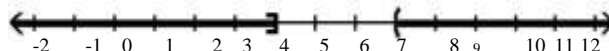

2) $-5 < x - 4 \leq 4$

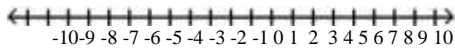

A) $(-1, 8]$

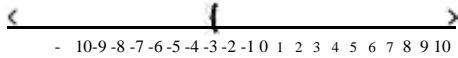

C) $[-1, 8)$

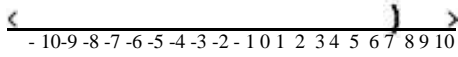

B) $(-9, 0]$

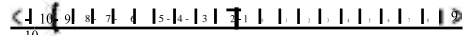

D) $[-9, 0)$

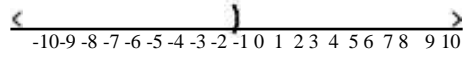

3) $19 \leq 5x - 1 \leq 29$



A) $[4, 6]$

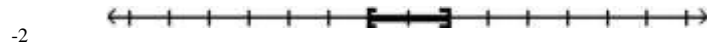

-1 0 1 2 3

B) $(4, 6)$

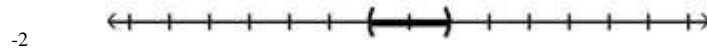

-1 0 1 2 3

C) $[-6, -4]$

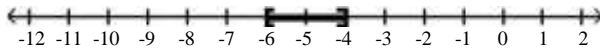

D) $(-6, -4)$

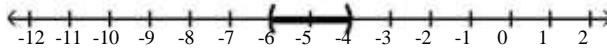

4) $-24 \leq -5x + 1 < -9$



A) $(2, 5]$

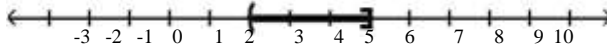

B) $[2, 5)$

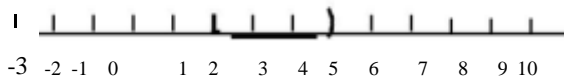

C) $[-5, -2)$



D) $(-5, -2]$



5) $-8 \leq -2x + 4 \leq 0$



A) $[2, 6]$

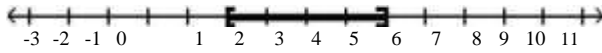

B) $(2, 6)$

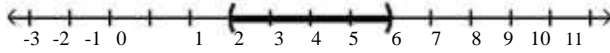

C) $[-6, -2]$

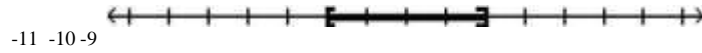

-8 -7 -6 -5 -4

D) $(-6, -2)$

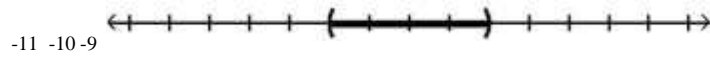

-8 -7 -6 -5 -4

6) $-4 \leq -4x - 12 < 4$

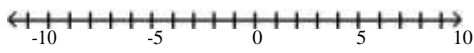

A) $(-4, -2]$

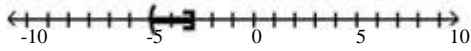

B) $(-\infty, -4]$

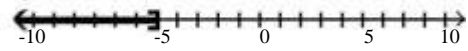

C) $(-\infty, -4)$ or $[-2, \infty)$

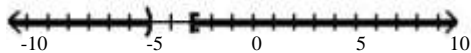

D) $[-4, -2)$

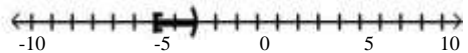

7) $3 \leq \frac{8}{5}x - 5 < 11$

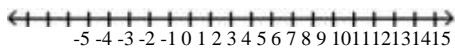

A) $[5, 10)$

B) $(5, 10]$

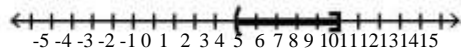
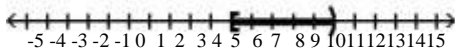

C) $[5, 6)$

D) $(5, 6]$

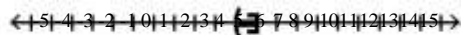
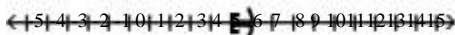

Solve the problem.

- 8) The formula for converting Fahrenheit temperature, F , to Celsius temperature, C , is

$$C = \frac{5}{9}(F - 32).$$

If Celsius temperature ranges from 60° to 115° , inclusive, what is the range for the Fahrenheit temperature?

- A) $[140^\circ\text{F}, 239^\circ\text{F}]$ B) $(140^\circ\text{F}, 239^\circ\text{F})$ C) $[-11^\circ\text{F}, -5^\circ\text{F}]$ D) $(-11^\circ\text{F}, -5^\circ\text{F})$

- 9) The formula for converting Celsius temperature, C , to Fahrenheit temperature, F , is F

$$= \frac{9}{5}C + 32.$$

If Fahrenheit temperature ranges from 50° to 122° , inclusive, what is the range for the Celsius temperature?

- A) $[10^\circ\text{C}, 50^\circ\text{C}]$ B) $(10^\circ\text{C}, 50^\circ\text{C})$
C) $[122^\circ\text{C}, 252^\circ\text{C}]$ D) $(122^\circ\text{C}, 252^\circ\text{C})$

- 10) On the first four exams, your grades are 75, 87, 62, and 76. You are hoping to earn a C in the course. This will occur if the average of your five exam grades is greater than or equal to 70 and less than 80. What range of grades on the fifth exam will result in earning a C?

- A) $[50, 100)$ B) $(50, 100]$ C) $[40, 90)$ D) $(40, 90]$

- 11) On the first four exams, your grades are 79, 87, 70, and 80. There is still a final exam, and it counts as two grades. You are hoping to earn a C in the course. This will occur if the average of your six exam grades is greater than or equal to 70 and less than 80. What range of grades on the final exam will result in earning a C?

- A) $[52, 82)$ B) $[52, 82]$ C) $[34, 84)$ D) $[34, 84]$

- 12) Parts for an automobile repair cost \$378. The mechanic charges \$27 per hour. If you receive an estimate for at least \$513 and at most \$621 for fixing the car, what is the time interval, in hours, that the mechanic will be working on the job?

- A) $[5, 9]$ B) $[19, 23]$ C) $[1, 9]$ D) $[1, 5]$

- 13) The formula $C = 1.5x + 19$ represents the estimated future cost of yearly attendance at State University, where C is the cost in thousands of dollars x years after 2002. Use a compound inequality to determine when the attendance costs will range from 32.5 to 38.5 thousand dollars.

- A) From 2011 to 2015 B) From 2010 to 2014 C) From 2012 to 2016 D) From 2012 to 2014

6 Solve Absolute Value Inequalities

MULTIPLE CHOICE. Choose the one alternative that best completes the statement or answers the question.

Solve the absolute value inequality. Other than \emptyset , use interval notation to express the solution set and graph the solution set on a number line.

1) $|x| < 8$

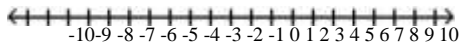

A) $(-8, 8)$

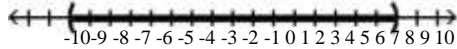

C) $[-8, 8]$

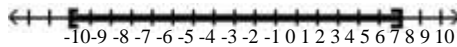

B) $(-\infty, -8) \cup (8, \infty)$

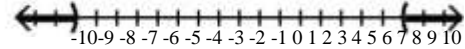

D) $(-\infty, -8] \cup [8, \infty)$

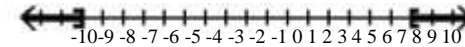

2) $|x| > 6$

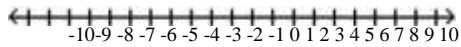

A) $(-\infty, -6) \cup (6, \infty)$

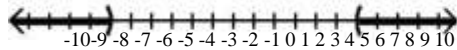

C) $[-6, 6]$

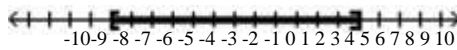

B) $(-6, 6)$

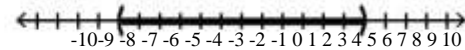

D) $(-\infty, -6] \cup [6, \infty)$

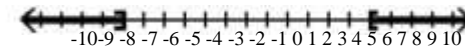

3) $|x - 5| < 0$

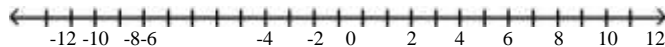

A) $(-5, 5)$

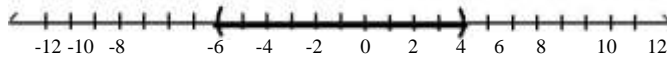

B) $(-\infty, 5)$

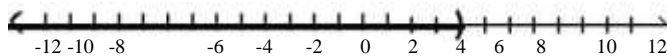

C) $(-5, \infty)$



D) \emptyset

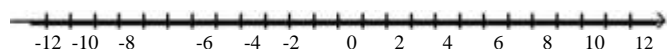

4) $|x + 4| > 0$

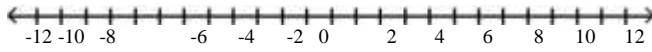

A) $(-\infty, -4) \cup (-4, \infty)$

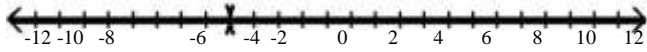

B) $(-4, 4)$

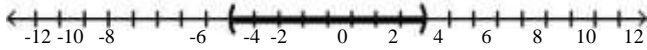

C) $(-4, \infty)$

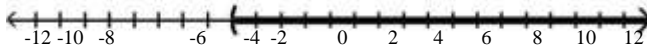

D) \emptyset

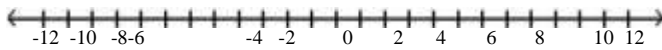

5) $|x + 5| \leq 0$

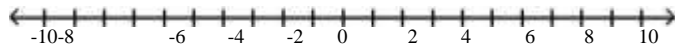

A) $\{-5\}$

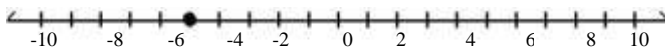

B) $\{5\}$

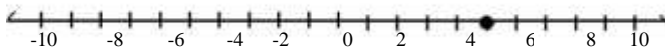

C) $(-\infty, -5)$

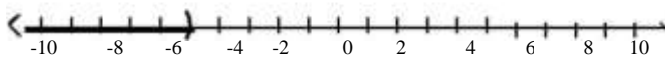

D) \emptyset

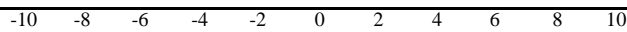

6) $|x + 8| \geq 0$

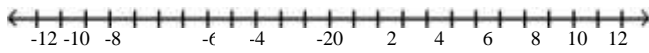

A) $(-\infty, \infty)$

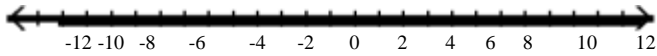

B) $\{-8\}$

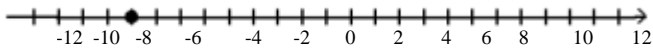

C) $(-8, 8)$

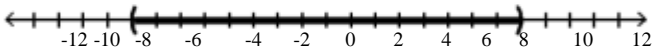

D) $(-8, \infty)$

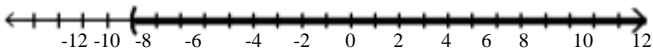

7) $|x - 6| < 4$

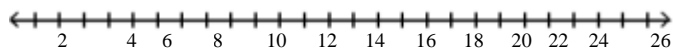

A) $(2, 10)$

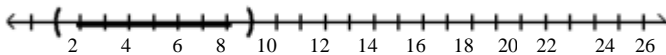

B) $[2, 10]$

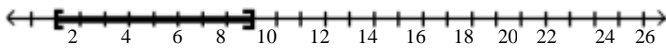

C) $(-\infty, 2) \cup (10, \infty)$

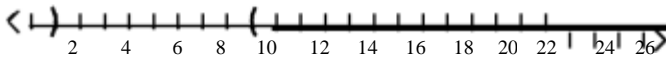

D) \emptyset

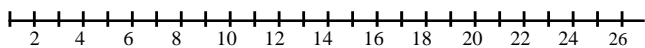

8) $|x + 9| - 4 \leq 0$



A) $[-13, -5]$

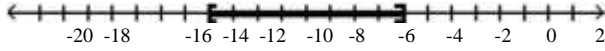

B) $(-13, -5)$

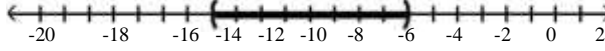

C) $[-13, 0]$

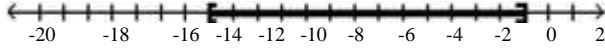

D) $(-\infty, -13] \cup [-5, \infty)$

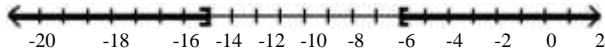

9) $|2(x + 1) + 4| \leq 10$

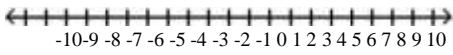

A) $[-8, 2]$

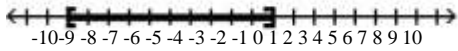

B) $(-8, 2)$

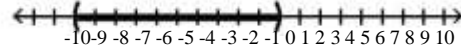

C) $[-6, 4]$

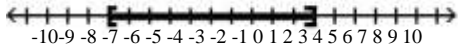

D) $(-6, 4)$

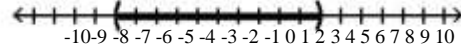

10) $\left| \frac{10y + 30}{3} \right| < 10$

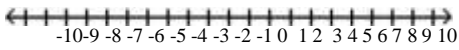

A) $(-6, 0)$

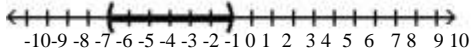

B) $(-\infty, -6) \cup (0, \infty)$

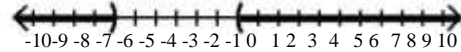

C) $(-6, 6)$

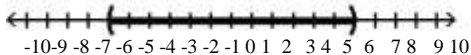

D) $(-\infty, -6) \cup (6, \infty)$

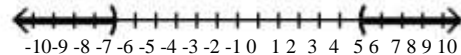

$$11) 5 + 1 - \frac{x}{2} \geq 8$$

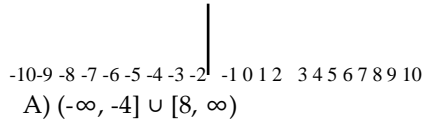

A) $(-\infty, -4] \cup [8, \infty)$

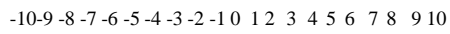

C) $(-\infty, -8] \cup [4, \infty)$

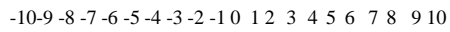

B) $[-4, 8]$

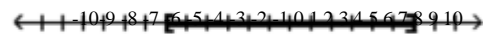

D) $[-8, 4]$

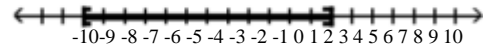

$$12) |7x + 11| + 4 < -3$$



A) $(-\infty, \frac{6}{7})$

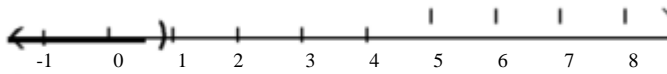

B) $(-\frac{8}{7}, \frac{6}{7})$

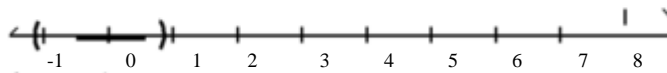

C) $(-\infty, -\frac{8}{7})$

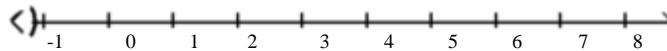

D) \emptyset

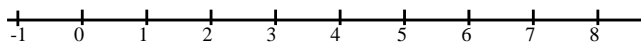

13) $|7x - 4| - 1 > -9$



A) $(-\infty, \infty)$



B) $[7, \infty)$



C) $(\frac{4}{7}, \frac{12}{7})$

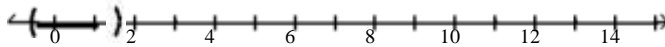

D) \emptyset

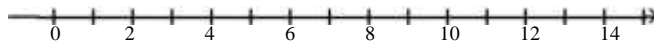

Solve the problem.

14) A spinner has five regions numbered 1 through 5. If the spinner is spun 100 times, we would expect about 20 of the outcomes to be Region 1. It can be determined that the spinner is unbalanced if x , the number of outcomes that result in Region 1, satisfies $\left| \frac{x - 20}{4} \right| \geq 1.645$. Describe the number of outcomes that determine an unbalanced spinner that is spun 100 times.

- A) Fewer than 14 or more than 26 outcomes
- C) Fewer than 17 or more than 29 outcomes

- B) Between 14 and 26 outcomes
- D) Between 17 and 29 outcomes

15) When a number is subtracted from -7 , the absolute value of the difference is more than 3. Use interval notation to express the set of all numbers that satisfy this condition.

- A) $(-\infty, -10) \cup (-4, \infty)$
- B) $(-\infty, -4) \cup (10, \infty)$
- C) $(-\infty, -10] \cup [-4, \infty)$
- D) $(-10, -4)$

16) A landscaping company sells 40-pound bags of top soil. The actual weight x of a bag, however, may differ from the advertised weight by as much as 0.75 pound. Write an inequality involving absolute value that expresses the relationship between the actual weight x of a bag and 40 pounds. Solve the inequality, and express the answer in interval form.

- A) $|40 - x| \leq 0.75$; $[39.25, 40.75]$
- B) $|40 + x| \leq 0.75$; $[39.25, 40.75]$
- C) $|x + 0.75| \leq 40$; $[39.25, \infty)$
- D) $|x| - 40 \leq 0.75$; $(-\infty, 40.75]$

Ch. 1 Equations and Inequalities

Answer Key

1.1 Graphs and Graphing Utilities

1 Plot Points in the Rectangular Coordinate System

- 1) A
- 2) A
- 3) A
- 4) A
- 5) A
- 6) A
- 7) A
- 8) A

2 Graph Equations in the Rectangular Coordinate System

- 1) A
- 2) A
- 3) A
- 4) A
- 5) A
- 6) A
- 7) A
- 8) A
- 9) A
- 10) A
- 11) A

3 Interpret Information About a Graphing Utility's Viewing Rectangle or Table

- 1) A
- 2) A
- 3) A
- 4) A
- 5) A
- 6) A
- 7) A
- 8) A

4 Use a Graph to Determine Intercepts

- 1) A
- 2) A
- 3) A
- 4) A
- 5) A
- 6) A
- 7) A

5 Interpret Information Given by Graphs

- 1) A
- 2) A
- 3) A
- 4) A
- 5) A
- 6) A
- 7) A
- 8) A
- 9) A

1.2 Linear Equations and Rational Equations

1 Solve Linear Equations in One Variable

- 1) A
- 2) A
- 3) A
- 4) A
- 5) A
- 6) A
- 7) A
- 8) A
- 9) A
- 10) A
- 11) A
- 12) A
- 13) A

2 Solve Linear Equations Containing Fractions

- 1) A
- 2) A
- 3) A
- 4) A
- 5) A
- 6) A
- 7) A
- 8) A
- 9) A
- 10) A
- 11) A
- 12) A

3 Solve Rational Equations with Variables in the Denominators

- 1) A
- 2) A
- 3) A
- 4) A
- 5) A
- 6) A
- 7) A
- 8) A
- 9) A
- 10) A
- 11) D
- 12) A
- 13) A
- 14) A
- 15) A

4 Recognize Identities, Conditional Equations, and Inconsistent Equations

- 1) A
- 2) B
- 3) C
- 4) B
- 5) A
- 6) C
- 7) A
- 8) C
- 9) B

- 10) B
- 11) C

1.3 Models and Applications

1 Use Linear Equations to Solve Problems

- 1) A
- 2) A
- 3) A
- 4) A
- 5) A
- 6) A
- 7) A
- 8) A
- 9) D
- 10) A
- 11) A
- 12) A
- 13) A
- 14) A
- 15) A
- 16) A
- 17) A
- 18) A
- 19) A
- 20) A
- 21) A
- 22) A
- 23) A
- 24) A
- 25) A
- 26) A

2 Solve a Formula for a Variable

- 1) A
- 2) A
- 3) A
- 4) A
- 5) A
- 6) A
- 7) A
- 8) A
- 9) A
- 10) A
- 11) A
- 12) A
- 13) A
- 14) A

1.4 Complex Numbers

1 Add and Subtract Complex Numbers

- 1) A
- 2) A

- 3) A
- 4) A
- 5) A
- 6) A
- 7) A

2 Multiply Complex Numbers

- 1) A
- 2) A
- 3) A
- 4) A
- 5) A
- 6) A
- 7) A
- 8) A
- 9) A
- 10) A
- 11) A
- 12) A

3 Divide Complex Numbers

- 1) A
- 2) A
- 3) A
- 4) A
- 5) A
- 6) A
- 7) A
- 8) A
- 9) A
- 10) A
- 11) A

4 Perform Operations with Square Roots of Negative Numbers

- 1) A
- 2) A
- 3) A
- 4) A
- 5) A
- 6) A
- 7) A
- 8) A
- 9) A
- 10) A
- 11) A
- 12) A

1.5 Quadratic Equations

1 Solve Quadratic Equations by Factoring

- 1) A
- 2) A
- 3) A
- 4) A
- 5) A
- 6) A
- 7) A
- 8) A

2 Solve Quadratic Equations by the Square Root Property

- 1) A
- 2) A
- 3) A
- 4) A
- 5) A

- 6) A
- 7) A
- 8) A
- 9) A
- 10) A
- 11) A

3 Solve Quadratic Equations by Completing the Square

- 1) A
- 2) A
- 3) A
- 4) A
- 5) A
- 6) A
- 7) A
- 8) A
- 9) A
- 10) A
- 11) A
- 12) A
- 13) A
- 14) A
- 15) A
- 16) A

4 Solve Quadratic Equations Using the Quadratic Formula

- 1) A
- 2) A
- 3) A
- 4) A
- 5) A
- 6) A
- 7) A
- 8) A

5 Use the Discriminant to Determine the Number and Type of Solutions

- 1) A
- 2) A
- 3) A

6 Determine the Most Efficient Method to Use When Solving a Quadratic Equation

- 1) A
- 2) A
- 3) A
- 4) A
- 5) A
- 6) A
- 7) A
- 8) A
- 9) A
- 10) A
- 11) A
- 12) A
- 13) A
- 14) A

- 15) A
- 16) A
- 17) A

- 18) A
- 19) A
- 20) A
- 21) A
- 22) A
- 23) A
- 24) A
- 25) A
- 26) A

7 Solve Problems Modeled by Quadratic Equations

- 1) A
- 2) A
- 3) A
- 4) A
- 5) A
- 6) A
- 7) A
- 8) A
- 9) A
- 10) A

1.6 Other Types of Equations

1 Solve Polynomial Equations by Factoring

- 1) A
- 2) A
- 3) A
- 4) A
- 5) A
- 6) A
- 7) A

2 Solve Radical Equations

- 1) A
- 2) A
- 3) A
- 4) A
- 5) A
- 6) A
- 7) A
- 8) A
- 9) A
- 10) A
- 11) A
- 12) A
- 13) A
- 14) D
- 15) A
- 16) A

17) $V = \frac{\pi r^2 h}{3}$

18) $\theta = \frac{2A}{r^2}$

- 19) A
- 20) A
- 21) A

- 22) A
- 23) A
- 24) A
- 25) A
- 26) A
- 27) A
- 28) A

3 Solve Equations with Rational Exponents

- 1) A
- 2) A
- 3) A
- 4) A
- 5) A
- 6) A
- 7) A
- 8) A

4 Solve Equations That Are Quadratic in Form

- 1) A
- 2) A
- 3) A
- 4) A
- 5) A
- 6) A
- 7) A
- 8) A
- 9) A
- 10) A
- 11) A
- 12) A
- 13) A
- 14) A
- 15) A
- 16) A
- 17) A
- 18) A
- 19) A
- 20) A
- 21) A
- 22) A
- 23) A

- 24) A
- 25) A
- 26) A
- 27) A
- 28) A
- 29) A
- 30) A
- 31) A
- 32) A
- 33) A
- 34) A
- 35) A

5 Solve Equations Involving Absolute Value

- 1) A

- 2) A
- 3) A
- 4) A
- 5) A
- 6) A
- 7) D
- 8) A
- 9) A
- 10) A
- 11) A
- 12) A
- 13) A
- 14) A
- 15) A
- 16) A
- 17) A

1.7 Linear Inequalities and Absolute Value Inequalities

1 Use Interval Notation

- 1) A
- 2) A
- 3) A
- 4) A
- 5) A
- 6) A
- 7) A

2 Find Intersections and Unions of Intervals

- 1) A
- 2) A
- 3) A
- 4) A
- 5) A
- 6) A

3 Solve Linear Inequalities

- 1) A
- 2) A
- 3) A
- 4) A
- 5) A
- 6) A
- 7) A
- 8) A
- 9) A
- 10) A
- 11) A
- 12) A
- 13) A
- 14) A
- 15) A
- 16) A
- 17) A
- 18) A
- 19) A
- 20) A
- 21) A

22) A

23) A

24) A

4 Recognize Inequalities with No Solution or All Real Numbers as Solutions

1) A

2) A

3) A

5 Solve Compound Inequalities

1) A

2) A

3) A

4) A

5) A

6) A

7) A

8) A

9) A

10) A

11) A

12) A

13) A

6 Solve Absolute Value Inequalities

1) A

2) A

3) D

4) A

5) A

6) A

7) A

8) A

9) A

10) A

11) A

12) D

13) A

14) A

15) A

16) A

