

Solution Manual for Organic and Biochemistry for Today 8th Edition Seager Slabaugh 1133605141 9781133605140

Full link download:

Test Bank:

<https://testbankpack.com/p/test-bank-for-organic-and-biochemistry-for-today-8th-edition-seager-slabaugh-1133605141-9781133605140/>

Solution Manual:

<https://testbankpack.com/p/solution-manual-for-organic-and-biochemistry-for-today-8th-edition-seager-slabaugh-1133605141-9781133605140/>

Chapter 2: Unsaturated Hydrocarbons

CHAPTER OUTLINE

12.1 The Nomenclature of Alkenes

12.2 The Geometry of Alkenes

12.3 Properties of Alkenes

12.4 Addition Polymers

12.5 Alkynes

12.6 Aromatic Compounds and the Benzene Structure

12.7 The Nomenclature of Benzene Derivatives

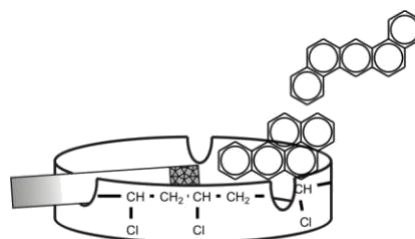

12.8 Properties and Uses of Aromatic Compounds

LEARNING OBJECTIVES/ASSESSMENT

When you have completed your study of this chapter, you should be able to:

1. Classify unsaturated hydrocarbons as alkenes, alkynes, or aromatics. (Section 12.1; Exercise 12.2)
2. Write the IUPAC names of alkenes from their molecular structures. (Section 12.1; Exercise 12.4)
3. Predict the existence of geometric (cis-trans) isomers from formulas of compounds. (Section 12.2; Exercise 12.18)
4. Write the names and structural formulas for geometric isomers. (Section 12.2; Exercise 12.20)
5. Write equations for addition reactions of alkenes, and use Markovnikov's rule to predict the major products of certain reactions. (Section 12.3; Exercise 12.26)
6. Write equations for addition polymerization, and list uses for addition polymers. (Section 12.4; Exercise 12.36)
7. Write the IUPAC names of alkynes from their molecular structures. (Section 12.5; Exercise 12.44)
8. Classify organic compounds as aliphatic or aromatic. (Section 12.6; Exercise 12.48)
9. Name and draw structural formulas for aromatic compounds. (Section 12.7; Exercises 12.52 and 12.54)
10. Recognize uses for specific aromatic compounds. (Section 12.8; Exercise 12.66)

LECTURE HINTS AND SUGGESTIONS

1. Explain the term "unsaturated" as the ability of a hydrocarbon to pick up smaller molecules. Describe how smaller molecules can be added to the double bond. The students have heard of the term "unsaturated" as it applies to fats. Explain that unsaturated fats have double bonds as part of their structure.
2. Use molecular models in class to illustrate the different types of isomerism. Students are easily confused as to when structures are equivalent or non-equivalent. Models are essential at this point to illustrate the differences. Two models which represent equivalent rather than isomeric structures can be shown to superimpose upon turning or upon rotation about single bonds.

3. When explaining the formation of addition polymers, first show with structural formulas how ethylene changes into polyethylene. Then show how by replacing one or more hydrogens in the ethylene with another group (e.g., chlorine, a benzene ring), essentially the same reaction can lead to a variety of different polymers. In each case be sure to give common examples of uses for the polymer.

SOLUTIONS FOR THE END OF CHAPTER EXERCISES

THE NOMENCLATURE OF ALKENES (SECTION 12.1) AND ALKYNES (SECTION 12.5)

- 12.1 An unsaturated hydrocarbon is a hydrocarbon containing one or more multiple bonds.

- 12.2 An alkene is a hydrocarbon that contains at least one carbon-carbon double bond.
 An alkyne is a hydrocarbon that contains at least one carbon-carbon triple bond.
 An aromatic hydrocarbon is a compound that contains a benzene ring or other similar feature.

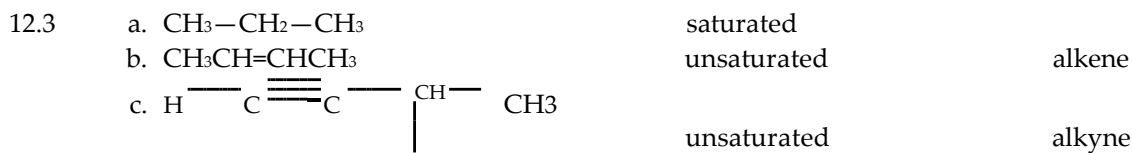
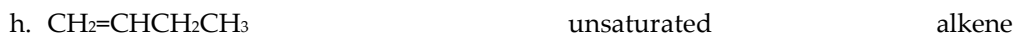
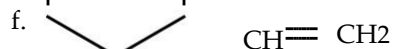
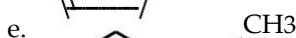
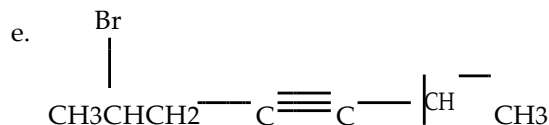
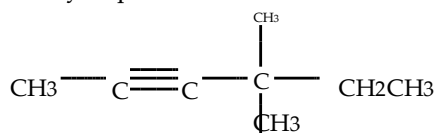
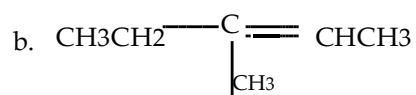
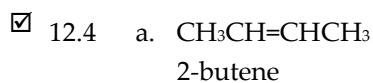
CH₃CH₃

6-bromo-2-methyl-3-heptyne

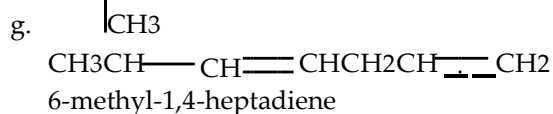
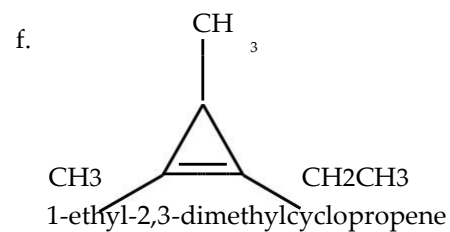

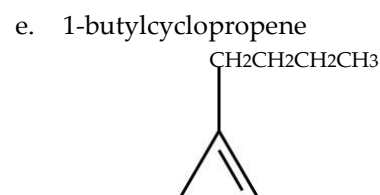
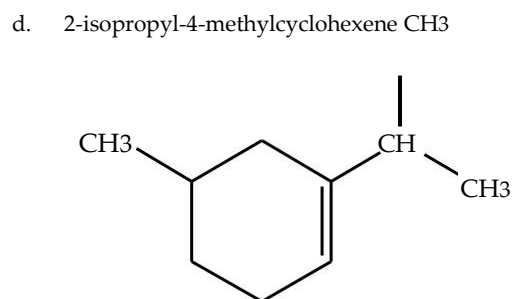
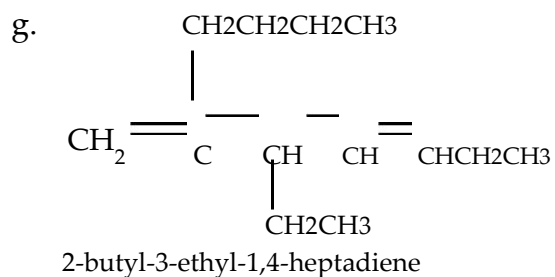
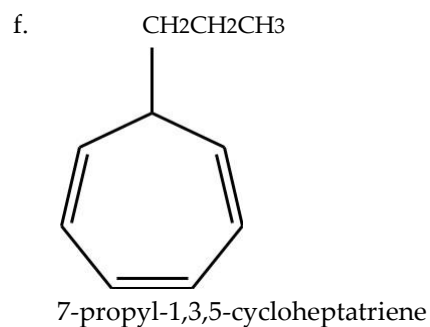
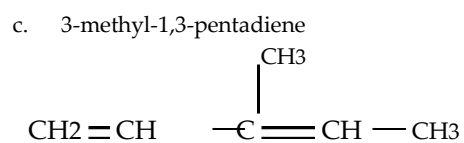
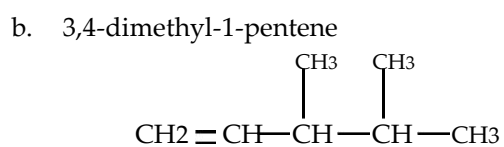
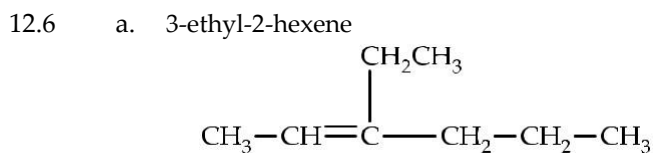
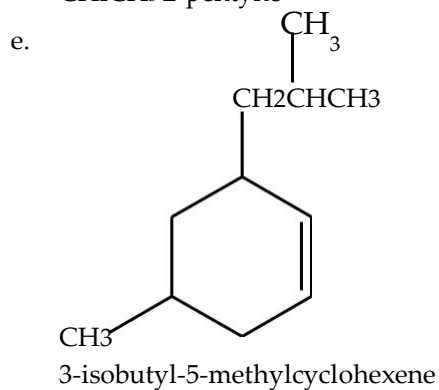
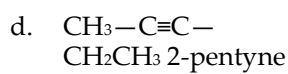
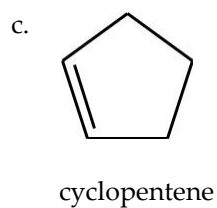
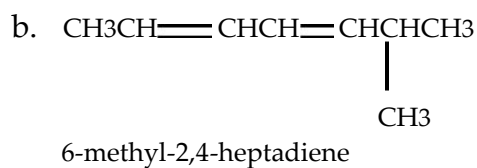
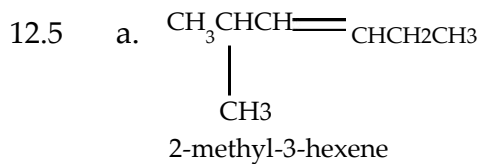

- 12.7 a. 4,4,5-trimethyl-2-heptyne

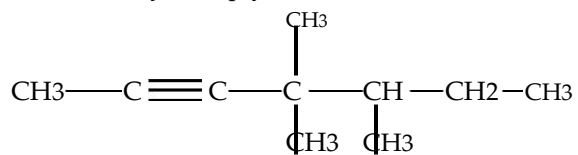

- b. 1,3-cyclohexadiene

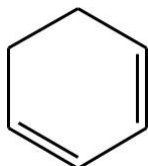

- c. 2-
- t*
- butyl-4,4-dimethyl-1-pentene

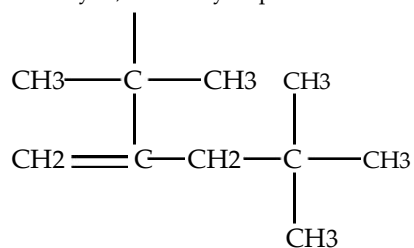

- d. 4-isopropyl-3,3-dimethyl-1,5-octadiene

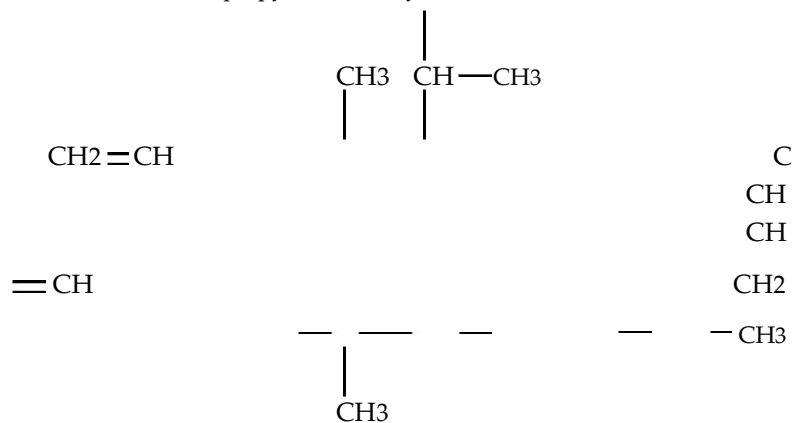

- e. 2-methyl-1,3-cyclopentadiene

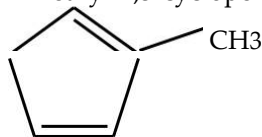

- f. 3-
- sec*
- butyl-3-
- t*
- butyl-1-heptyne

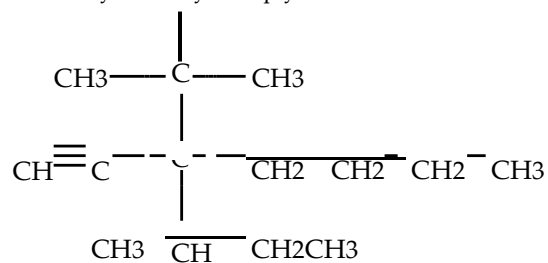

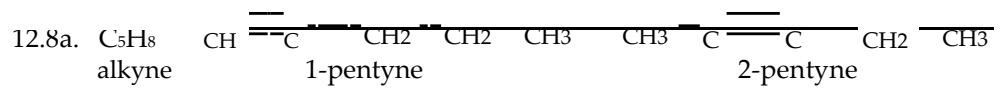

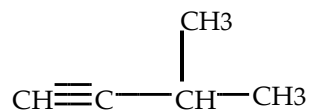

3-methyl-1-butyne

b. CH₂ diene

1,2-pentadiene

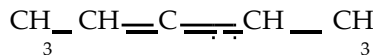

2,3-pentadiene



1,3-pentadiene



1,4-pentadiene

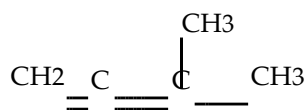

3-methyl-1,2-butadiene

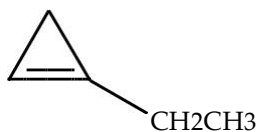
c. CH₂ cyclic alkene

1-ethylcyclopropene



3-ethylcyclopropene

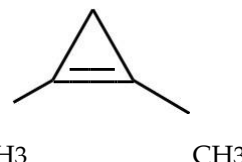

1,2-dimethylcyclopropene

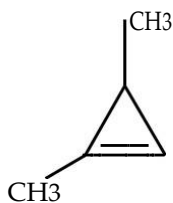

1,3-dimethylcyclopropene

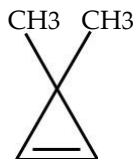

3,3-dimethylcyclopropene

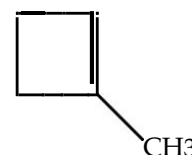

1-methylcyclobutene

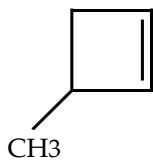

3-methylcyclobutene

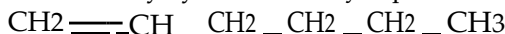

cyclopentene

12.9C₆H₁₂

1-hexene



2-hexene

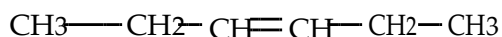

3-hexene

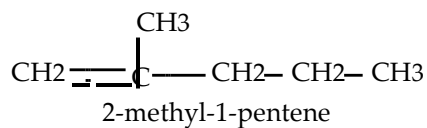

2-methyl-1-pentene

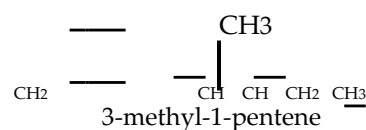

3-methyl-1-pentene



- b. incorrect = 3,5-heptadiene
corrected = 2,4-heptadiene

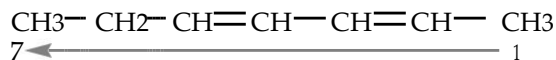

- c. incorrect = 4-methylcyclobutene
corrected = 3-methylcyclobutene

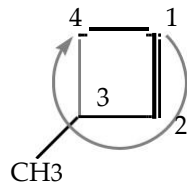

THE GEOMETRY OF ALKENES (SECTION 12.2)

- 12.13 Carbon atoms in a double bond each have 3 sp^2 hybrid orbitals as well 1 unhybridized p orbital.
- 12.14 Pi bonds are formed when unhybridized p orbitals overlap sideways. The pi bond is represented by π . The pi bond contains 2 electrons.
- 12.15 Carbon atoms in a double bond have a trigonal planar geometry where the two atoms attached to the double bonded carbon atom as well as the other carbon atom in the double bond are in the same plane, separated by bond angles of 120° .
- 12.16 Structural isomers have a different order of linkage of atoms. Geometric isomers have the same order of linkage of atoms; however, the three dimensional structures are unique because of restricted rotation as a result of a ring or a double bond.

- 12.17a. Alkenes that do not show geometric isomerism.

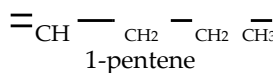

isomerism. There are four compounds.

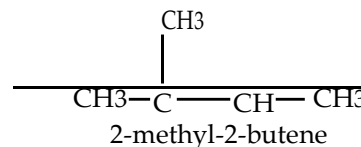
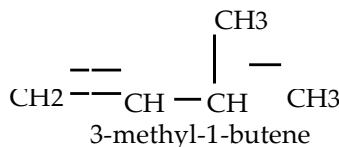
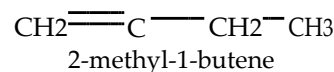

- b. Alkenes that do show geometric isomerism. There is one *cis*- and one *trans*- compound.

$\text{CH}_3 - \text{CH} = \text{CH} - \text{CH}_2 - \text{CH}_3$
2-pentene can exist as *cis*- or *trans*-

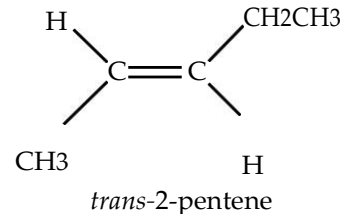
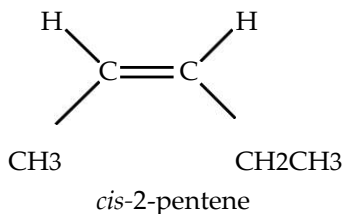

- 12.18 a. $\text{CH}_3\text{CH}_2\text{CH}_2\text{CH}_2\text{CH}=\text{CH}_2$; no geometric isomers

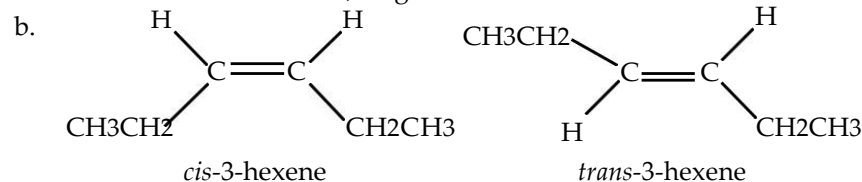

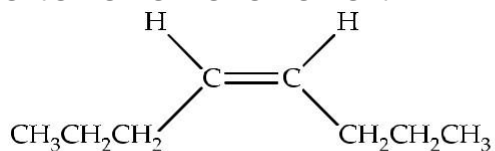
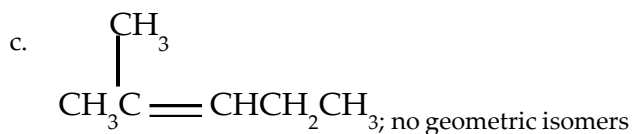

cis-4-octene

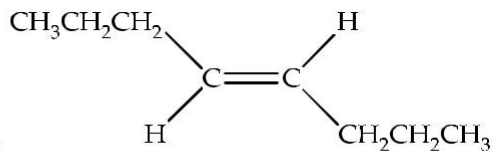

trans-4-octene

- b. no geometric isomers (2 $-\text{CH}_2\text{CH}_3$ groups attached to one of the double bond carbon atoms)

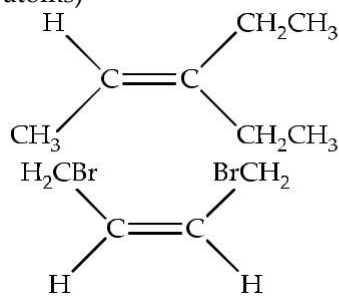

cis-1,4-dibromo-2-butene

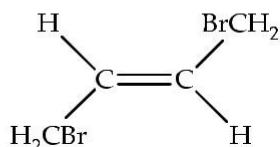

trans-1,4-dibromo-2-butene

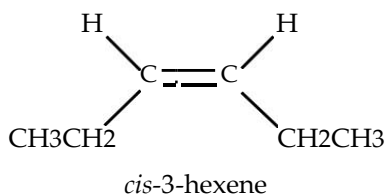
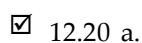

cis-3-hexene

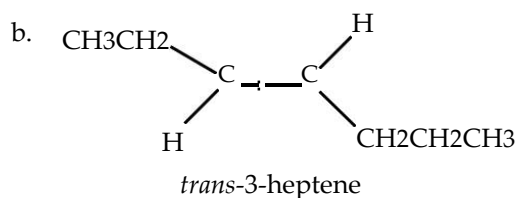

trans-3-heptene

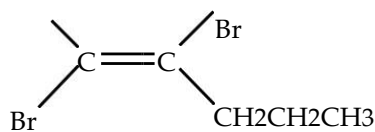
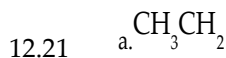

trans-3,4-dibromo-3-heptene

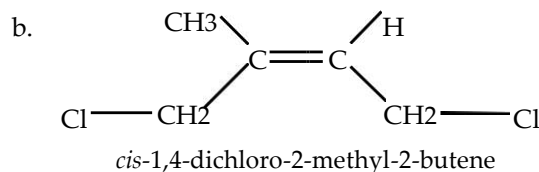

cis-1,4-dichloro-2-methyl-2-butene

PROPERTIES OF ALKENES (SECTION 12.3)

12.22 Alkenes and alkanes are both nonpolar molecules that have low solubility in water and high solubility in nonpolar solvents. They are also less dense than water.

- 12.23a. $\text{A}_2 + \text{C}_3\text{H}_6 \rightarrow \text{C}_3\text{H}_6\text{A}_2$ addition
 b. $\text{A}_2 + \text{C}_3\text{H}_6 \rightarrow \text{C}_3\text{H}_5\text{A} + \text{HA}$ not addition (substitution)
 c. $\text{HA} + \text{C}_4\text{H}_8 \rightarrow \text{C}_4\text{H}_9\text{A}$ addition
 d. $3\text{O}_2 + \text{C}_2\text{H}_4 \rightarrow 2\text{CO}_2 + \text{H}_2\text{O}$ not addition (combustion)
 e. $\text{C}_7\text{H}_{16} \rightarrow \text{C}_7\text{H}_8 + 4\text{H}_2$ not addition (decomposition)

12.24 Markovnikov's rule states that when a heteroatomic compound containing hydrogen is added to a multiple bond, the hydrogen will attach to the carbon atom in the multiple bond that is directly bonded to more hydrogen atoms. The following reaction is an example of this rule:

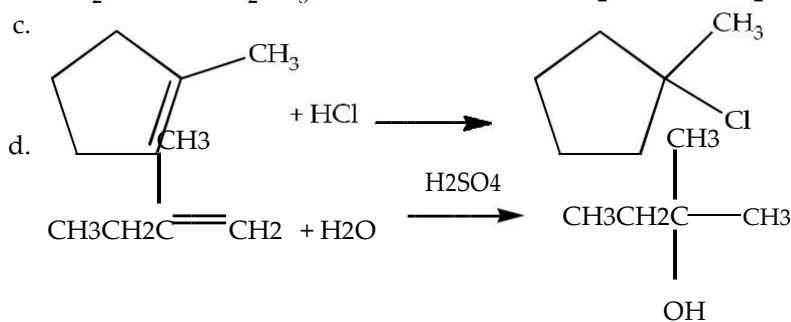
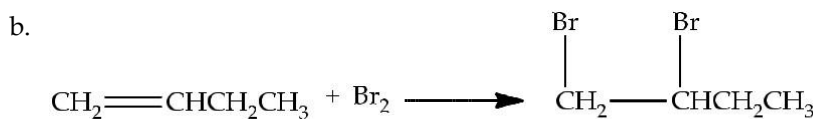
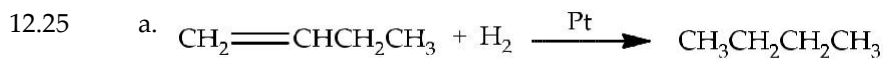
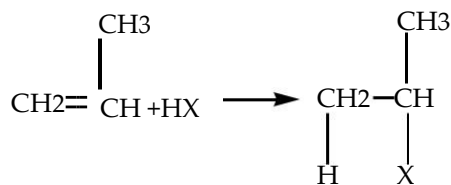

12.26

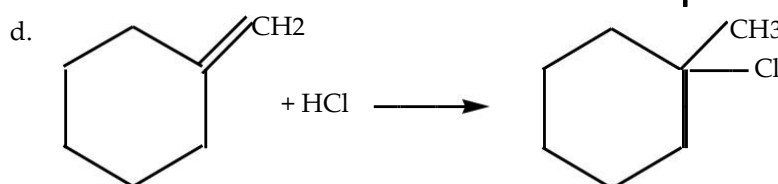
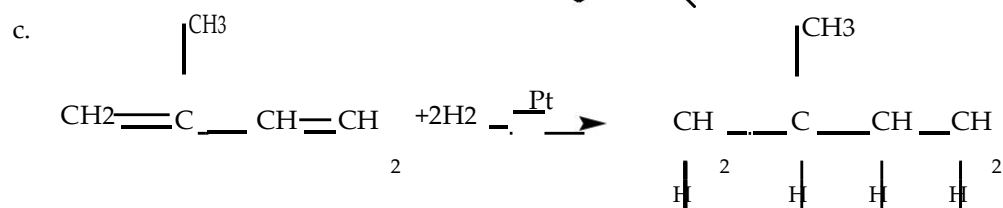
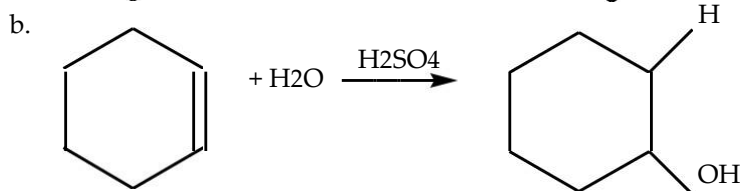
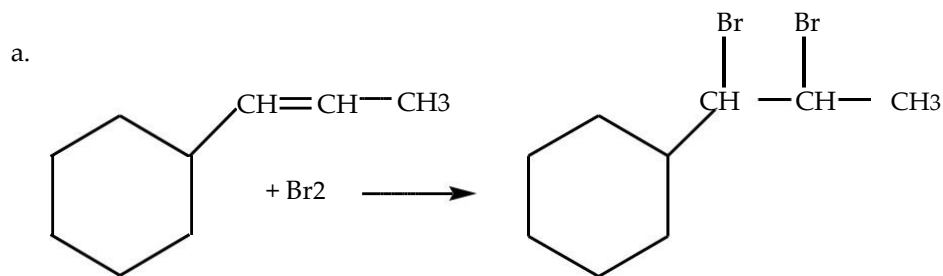

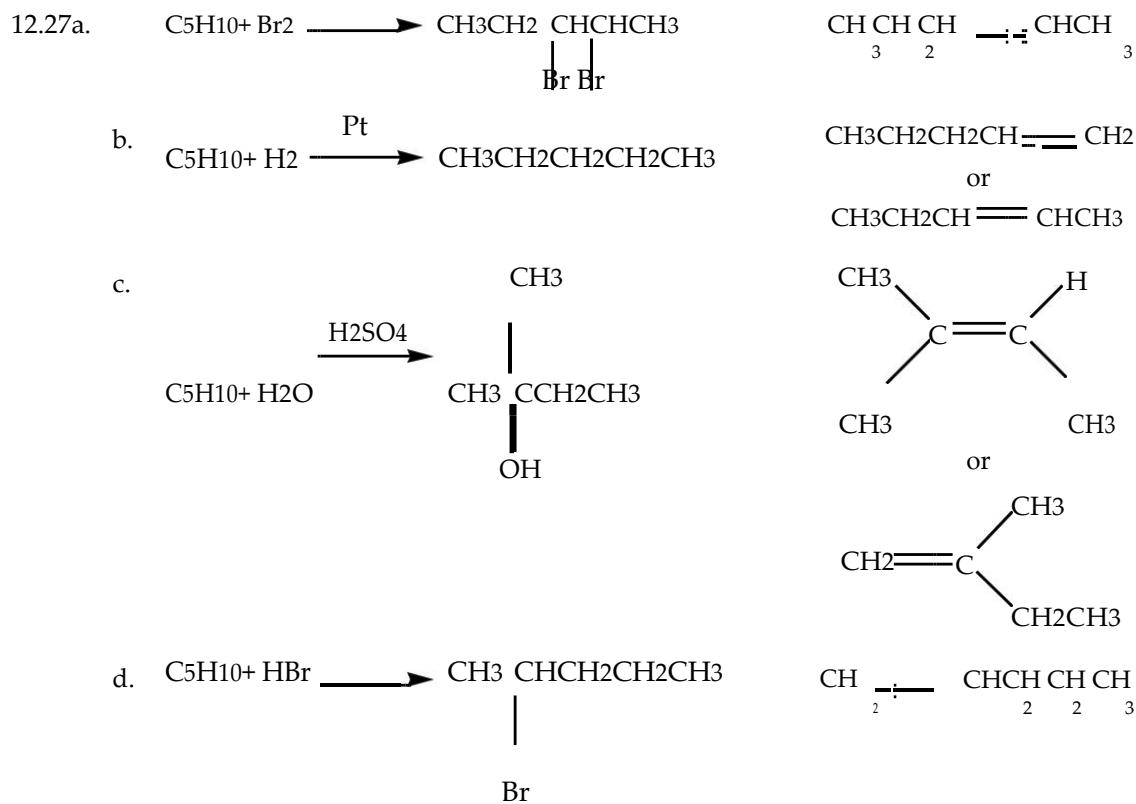

- 12.28
- To prepare 3,4-dibromohexane from 3-hexene, I would use Br_2 .
 - To prepare hexane from 3-hexene, I would use hydrogen gas and a platinum catalyst.
 - To prepare 3-chlorohexane from 3-hexene, I would use HCl .
 - To prepare 3-hydroxyhexane (3-hexanol) from 3-hexene, I would use water and a sulfuric acid catalyst.

12.29 An important commercial application of hydrogenation is the hydrogenation of liquid vegetable oils to produce a solid vegetable shortening.

12.30 Adding reddish-brown bromine to cyclohexane will produce a reddish-brown solution. Adding reddish-brown bromine to 2-hexene will produce a clear solution in a very short time, since the alkene undergoes an addition reaction. The differences in the chemical reactivity of these substances will allow them to be differentiated.

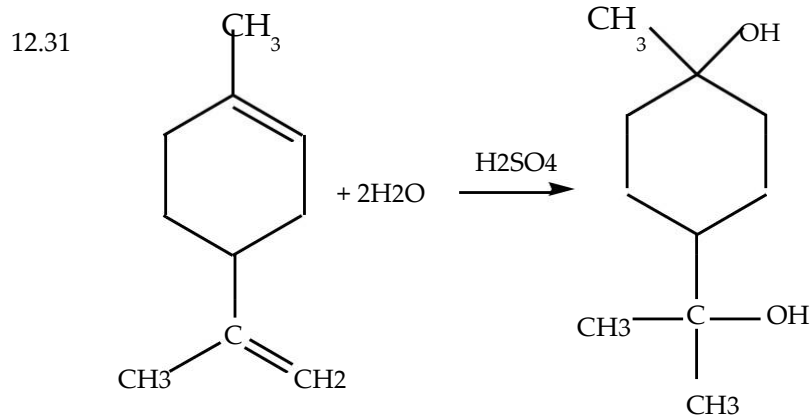

ADDITION POLYMERS (SECTION 12.4)

12.32 A monomer is the starting material for a polymer. It can be a small molecule.

A polymer is a large molecule made up of repeating units (often thousands of repeating units).

An addition polymer is a polymer formed by the reaction of monomers that contained multiple bonds to form the repeating units of a polymer.

A copolymer is a polymer formed by the reaction of at least two different types of monomers.

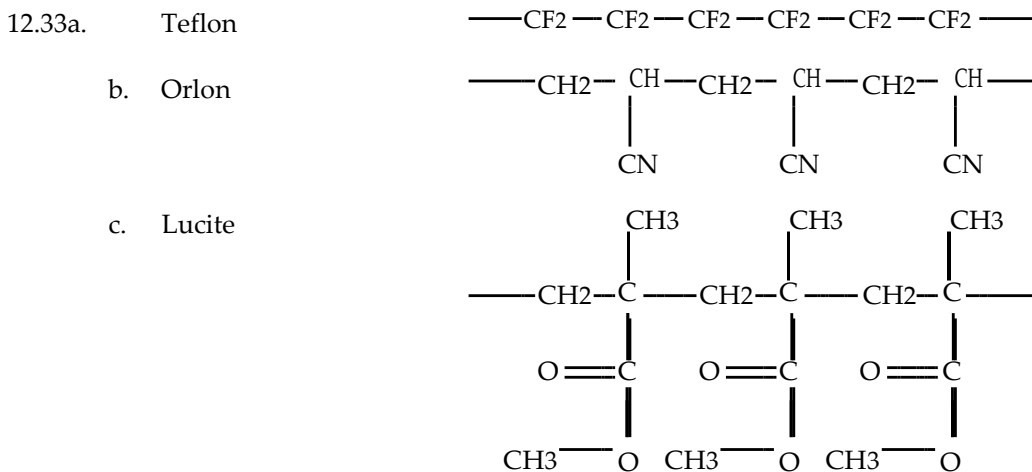

12.34 All of the monomers in Table 12.3 contain one carbon-carbon double bond.

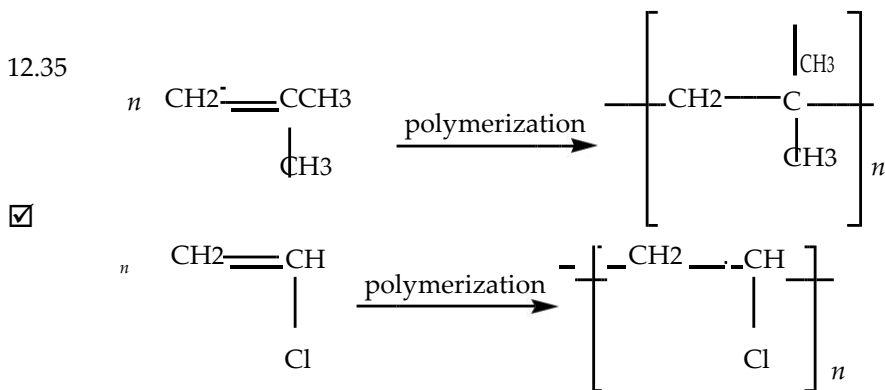

- | | |
|-------------------|--|
| 12.37a. Styrofoam | Food coolers, drinking cups, insulation |
| b. Acrilan | Carpets, fabrics |
| c. Plexiglass | Airplane windows, paint, contact lenses, fiber optics |
| d. PVC | Synthetic leather, floor tiles, garden hoses, water pipe |
| e. polypropylene | Carpet fiber, pipes, bottles, artificial turf |

ALKYNES (SECTION 12.5)

12.38 Each carbon atom bonded with a triple bond has two *sp* hybrid orbitals.

12.39 A triple bond of an alkyne is composed of 1 sigma and two pi bonds.

12.40 The geometry of a triple bond is linear.

THE NOMENCLATURE OF BENZENE DERIVATIVES (SECTION 12.7)

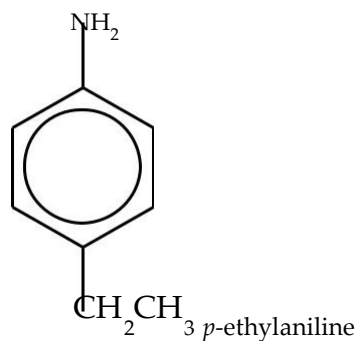
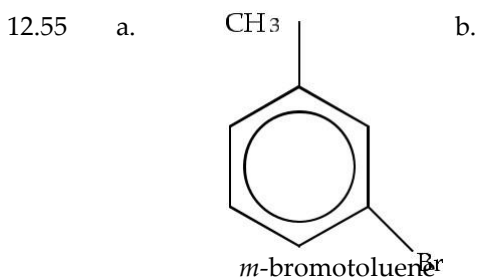
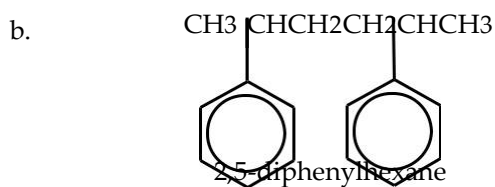
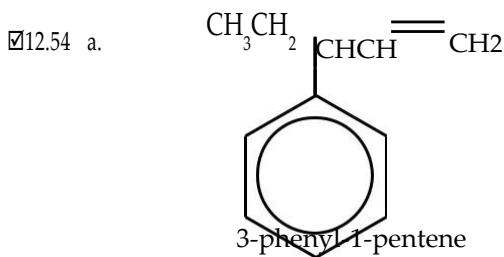
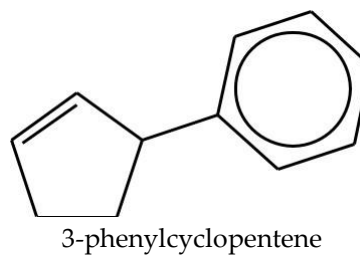
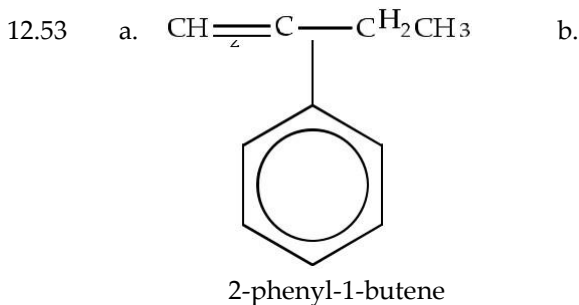
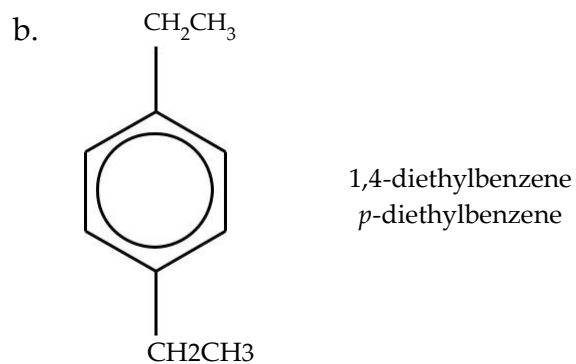
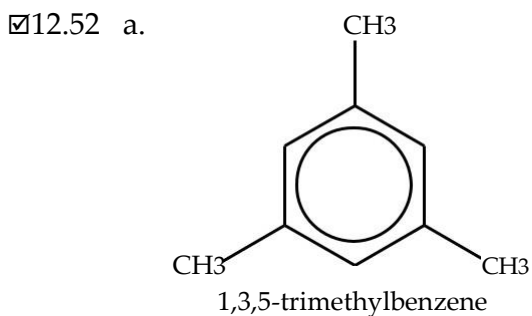
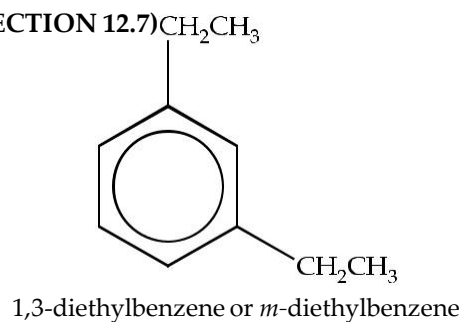
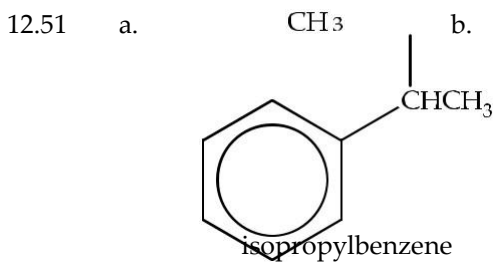

12.56 a.

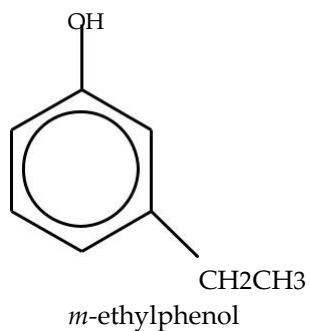

b.

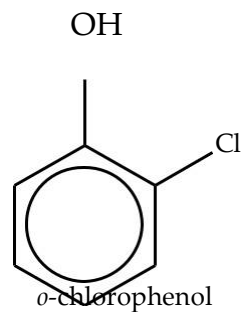

12.57 a.

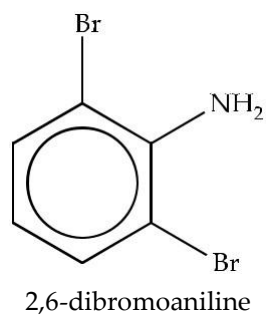

b.

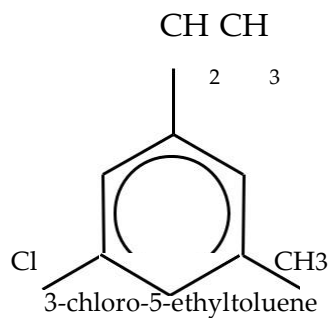

12.58 a.

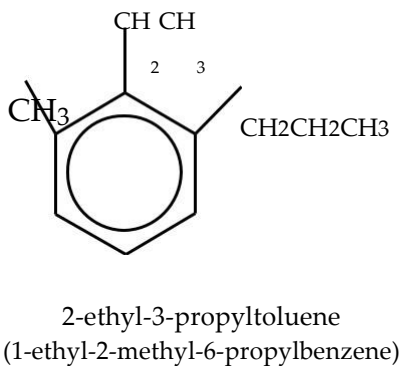

b.

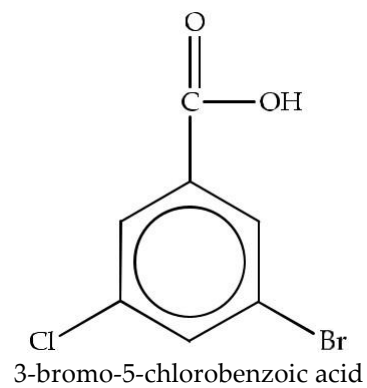

12.59 a.

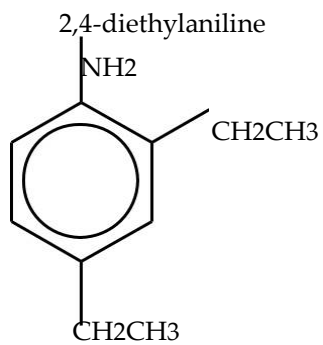

b.4-ethyltoluene

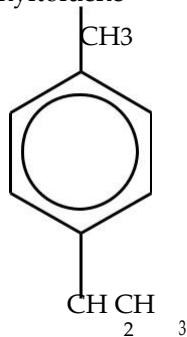
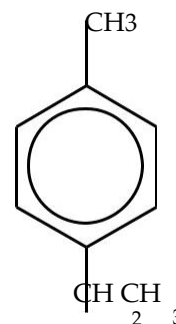
c. p -ethyltoluene

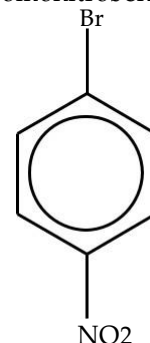
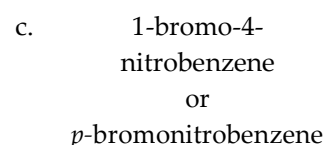
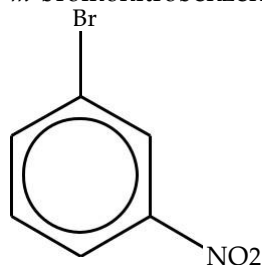
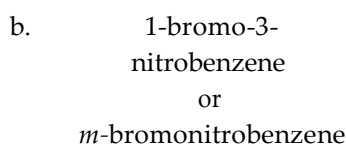
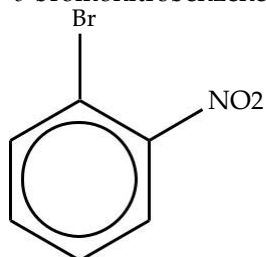
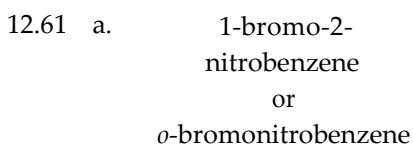
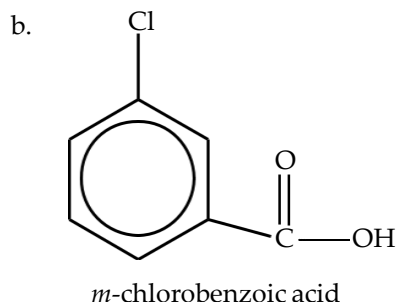
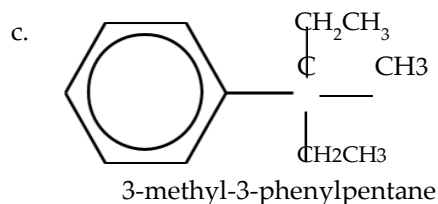
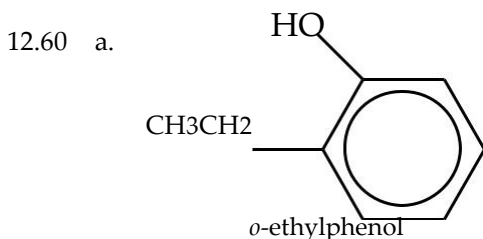

PROPERTIES AND USES OF AROMATIC COMPOUNDS (SECTION 12.8)

- 12.62 Aromatic hydrocarbons are nonpolar molecules that are insoluble in water and soluble in nonpolar solvents. They are also less dense than water.
- 12.63 Benzene does not readily undergo addition reactions characteristic of other unsaturated compounds because the delocalized pi cloud of the benzene ring makes the ring so stable that addition reactions do not occur. An addition reaction would result in the loss of one of the double bonds, and consequently, disrupt the delocalized system. This is not favored because it results in a loss of stability. Benzene, therefore, undergoes substitution reactions instead of addition reactions.
- 12.64 Cyclohexene readily undergoes addition reactions. Benzene resists addition reactions and favors substitution reactions. Both benzene and cyclohexene can undergo combustion.
- 12.65
- | | |
|-------------------------------|------------------|
| a. A solvent | benzene, toluene |
| b. A vitamin | riboflavin |
| c. An essential amino acid | phenylalanine |
| d. Starting material for dyes | aniline |

- ☑ 12.66
- | | |
|--|---------|
| a. Used in the production of Formica® | phenol |
| b. A starting material for polystyrene | styrene |
| c. Used to manufacture drugs | aniline |
| d. A starting material for Bakelite® | phenol |

ADDITIONAL EXERCISES

12.67 Alkynes have slightly higher boiling points and densities than structurally equivalent alkanes because the linear alkyne molecules can pack more closely together than the alkane molecules. This close packing allows for stronger dispersion forces, which cause the alkynes to have higher boiling points and densities than structurally equivalent alkanes.

12.68 Heat provides additional energy to the reactants which increases the likelihood of a “successful collision” because reactions occur when reactants collide with sufficient energy to produce the transition state. Heat also increases the number of collisions. Consequently, the reaction rate should increase as the reaction is heated.

Pressure increases the number of collisions between reactant molecules, which increases the likelihood of a “successful collision.” Consequently, the reaction rate should increase as the pressure is increased.

Catalysts lower the activation energy required for a reaction to occur; therefore, the reaction rate should increase when a catalyst is added to the reaction.

12.69 Propene reacts with a diatomic molecule whose atoms have the electronic configuration of $1s^2 2s^2 2p^6 3s^2 3p^5$ (Cl_2) to produce 1,2-dichloropropane.

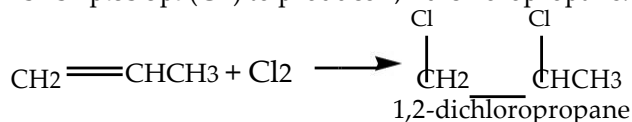

12.70 $\text{alkene} + \text{water} \xrightarrow{\text{H}_2\text{SO}_4} \text{alcohol} + 10 \text{ kcal/mol}$

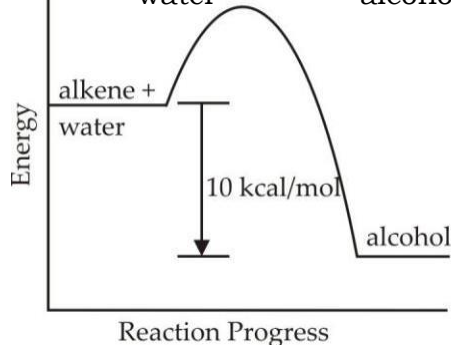

This reaction is exothermic because energy is a product of the reaction.

12.71 When 25.0 g of 2-butene reacts with 25.0 g of iodine, iodine is the limiting reactant. Only 0.0985 moles of product will be produced.

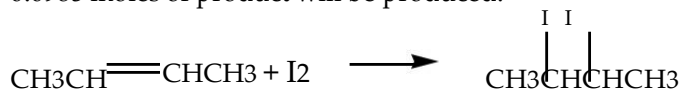

$$25.0 \text{ g C}_4\text{H}_8 \left(\frac{1 \text{ mole C}_4\text{H}_8}{56.1 \text{ g C}_4\text{H}_8} \right) = 0.446 \text{ moles C}_4\text{H}_8$$

$$25.0 \text{ g I}_2 \left(\frac{1 \text{ mole C}_4\text{H}_8 \text{ I}_2}{254 \text{ g I}_2} \right) = 0.0984 \text{ moles C}_4\text{H}_8 \text{ I}_2$$

ALLIED HEALTH EXAM CONNECTION

- 12.72 (a) Benzene and (d) phenol are aromatic compounds. (b) Ethyl alcohol and (c) methane are aliphatic compounds.
- 12.73 a. C_nH_{2n} (2) an alkene with one C=C bond
 b. $\text{C}_n\text{H}_{2n+2}$ (1) an alkane
 c. $\text{C}_n\text{H}_{2n-2}$ (3) an alkyne with one C≡C bond
- 12.74 $\text{CH}_2=\text{CH}-\text{CH}_2-\text{CH}_2-\text{CH}_3$ is an example of (c) an alkene.
- 12.75 The correct structural formula for ethyne is (c) $\text{H}-\text{C}\equiv\text{C}-\text{H}$.
- 12.76 Protection of the skin from the harmful effects of ultraviolet light is provided by the pigment (b) melanin, which is produced by specialized cells within the stratum germinativum.

CHEMISTRY FOR THOUGHT

12.77

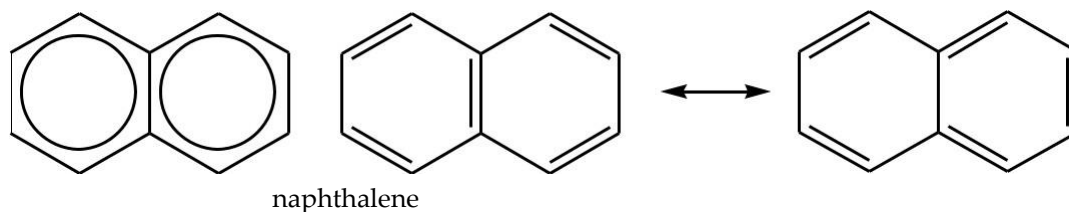

- 12.78 Propene does not exhibit geometric isomerism because one of the carbon atoms in the double bond is also bonded to two hydrogen atoms. In order to exhibit geometric isomerism, both carbon atoms in the double bond must also be bonded to two unique groups.
- 12.79 Limonene contains 10 carbon atoms, including a six membered ring and two double bonds. It is likely to be a liquid at room temperature because the structure allows the molecules to pack fairly close together.
- 12.80 $5.0 \times 10^4 \text{ u} \left(\frac{1 \text{ ethylene monomer}}{28.0 \text{ u}} \right) = 1.8 \times 10^3 \text{ ethylene monomers}$
- 12.81 The human body gets its supply of aromatic compounds through diet. The foods humans eat contain aromatic compounds.
- 12.82 Addition polymers form a large extended structure. Polyvinyl acetate prevents the formation of sharp fragments in automobile safety glass because it holds the glass together on a flexible surface after the glass is broken. The copolymer of styrene and 1,3-butadiene allows a large flexible bubble to be formed by the girl chewing gum.

- 12.83 Alkanes can't undergo addition polymerization because they lack the reactive double bond that allows addition polymerization to occur.
- 12.84 The polymer that produces hydrogen cyanide, HCN, is polyacrylonitrile.
The polymer that produces hydrogen chloride, HCl, is poly (vinyl chloride).

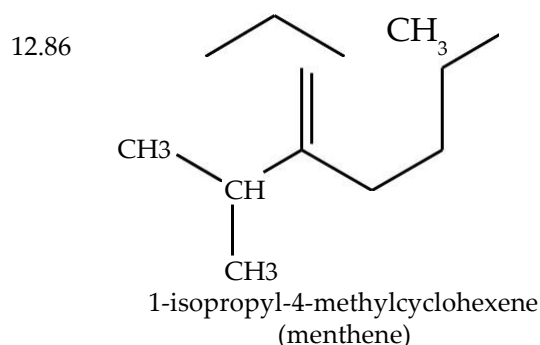
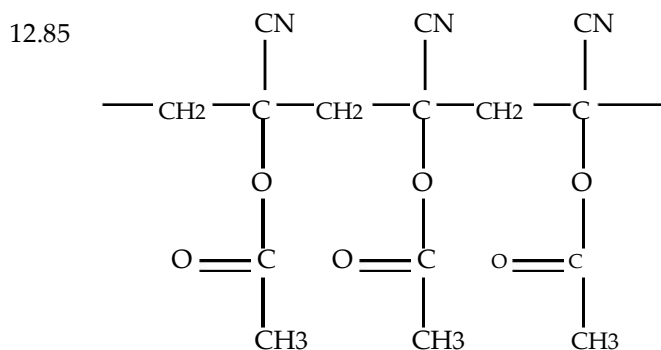

EXAM QUESTIONS

MULTIPLE CHOICE

- Name a difference between a saturated and an unsaturated hydrocarbon.
 - Saturated hydrocarbons are composed of only carbon and hydrogen, and unsaturated hydrocarbons include other atoms than just carbon and hydrogen.
 - Saturated hydrocarbons do not contain multiple bonds between carbons, but unsaturated hydrocarbons do contain multiple bonds.
 - Unsaturated hydrocarbons are flammable but saturated hydrocarbons are not.
 - Saturated hydrocarbons are essentially insoluble. Unsaturated hydrocarbons are soluble.

Answer: B

- Which characteristic relates to alkenes, but not the other hydrocarbon families?
 - saturation
 - double bonds
 - halogen substitution
 - triple bonds

Answer: C

- What number would be used to indicate the double bond position in the IUPAC name for $\text{CH}_3\text{CH}_2\text{CH}=\text{CHCH}_3$?
 - 1
 - 2
 - 3
 - 4

Answer: B

4. In the IUPAC name for the following compound, the -Br group is located at what position? $\text{CH}_3\text{CHBrCH}=\text{CH}_2$
- a. 1 b. 2 c. 3 d. 4

Answer: C

5. What is the IUPAC name of the following compound?
- a. 3-ethyl-1-butene c. 3-ethyl-3-butene
b. 2-ethyl-2-butene d. 2-ethyl-1-butene

Answer: D

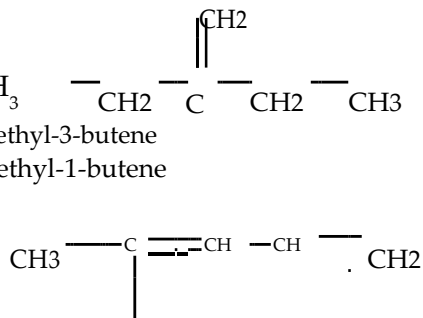

6. What is the IUPAC name of the following compound?
- a. 2-methyl-1,4-pentadiene c. 4-methyl-1,3-pentadiene
b. 2-methyl-2,4-dipentene d. 4-methyl-2,4-pentadiene

Answer: C

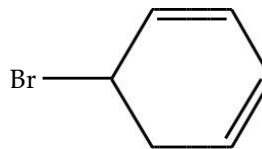

7. What is a correct IUPAC name of the following compound?
- a. 5-bromo-1,3-cyclohexadiene c. 2-bromo-1,4-cyclohexadiene
b. 2-bromo-1,3-cyclohexadiene d. 3-bromo-1,5-cyclohexadiene

Answer: A

8. Which of the following compounds could exist in the form of two geometric isomers?

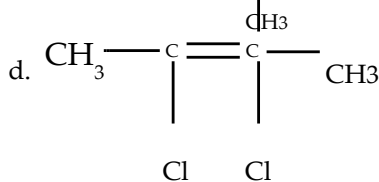
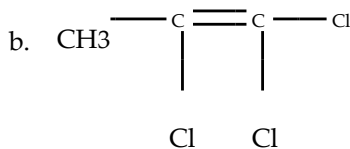
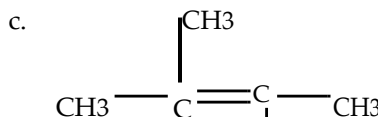
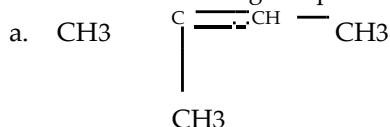

Answer: D

9. Which of the following can exhibit geometric isomerism?
- a. 1-propene c. 2,3-dimethyl-2-butene b. 1,2,2-tribromoethene d. 1-bromo-1-propene

Answer: D

10. Which of the following compounds is *trans*-3-hexene?

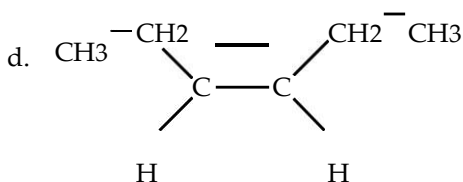
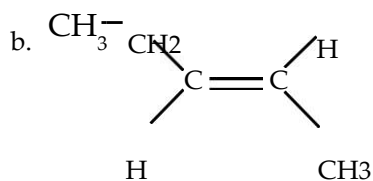
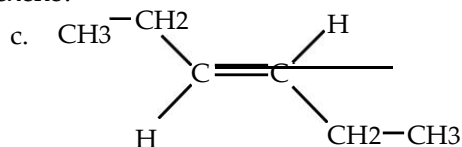
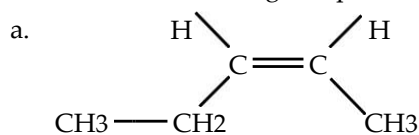

Answer: C

11. Which of the compounds below has a geometric isomer?

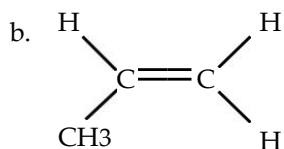
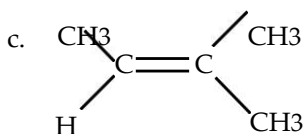
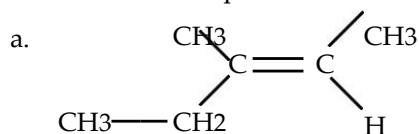

d. None of these

Answer: A

12. Which of the following represents an addition reaction?

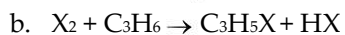
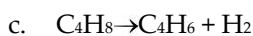
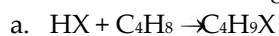

d. more than one response is correct

Answer: A

13. Select the major product that would result from the following reaction.

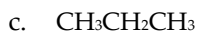
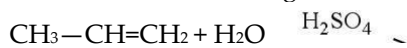

Answer: A

14. Select the major product that would result from the following reaction.

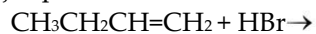

Answer: C

15. Which of the following reagents is required for the conversion of cyclohexene to cyclohexane?

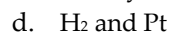
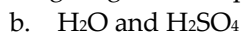
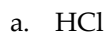

Answer: D

16. Which addition polymer produced from $\text{CH}_3-\text{CH}=\text{CH}-\text{Cl}$?

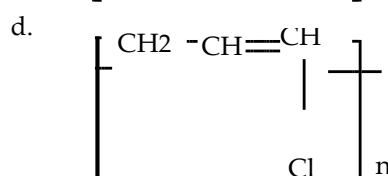
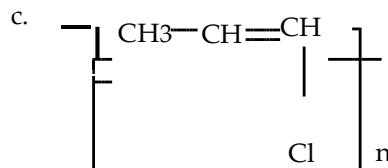
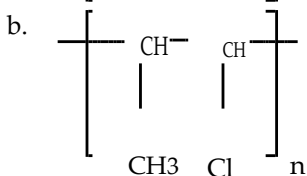
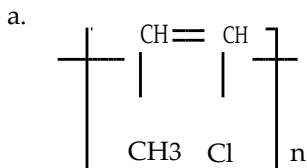

Answer: B

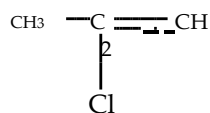

17. What is the addition polymer produced from the monomer,

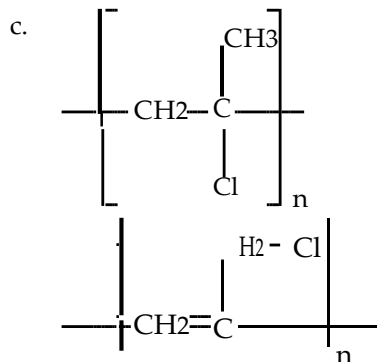
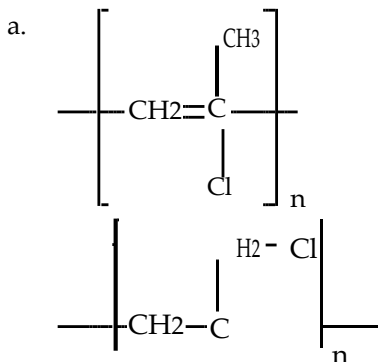

Answer: C

18. A portion of the structure of Acrilan is shown. What is the structure of the monomer?

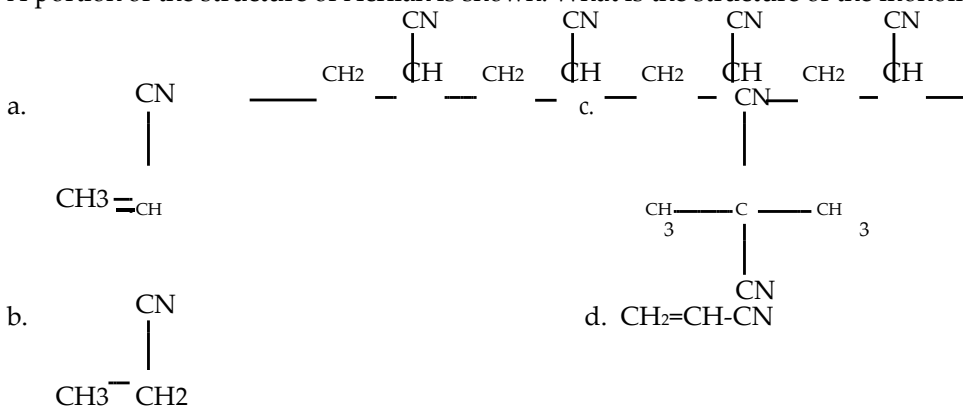

Answer: D

19. Which of the following is the monomer for Teflon®?

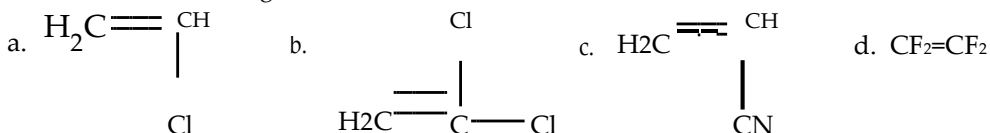

Answer: D

20. Which is the formula for an alkene?

- a. CH_3CHCH_2
- b. $\text{CH}_3\text{CH}_2\text{CH}_2$
- c. $\text{CH}_3\text{CH}_3\text{CH}_2$
- d. There is more than one correct response.

Answer: A

21. Which is the formula for an alkyne?

- a. $\text{CH}_3\text{CH}_2\text{CCH}_2$
- b. $\text{CH}_3\text{CH}_2\text{CH}_2\text{CH}_3$
- c. $\text{CH}_3\text{CH}_2\text{CCH}$
- d. $\text{CH}_3\text{CH}_2\text{CCH}_2$

Answer: C

22. Which is a difference between butane and butene?

- a. butane burns and butene does not
- b. the presence of a double bond
- c. they are isomers
- d. the presence of a triple bond

Answer: B

23. Which is a difference between butene and cyclobutene?

- a. They are isomers.
- b. Cyclobutene has 2 double bonds, butene does not.
- c. The location of the double bond is terminal in cyclobutene, but between interior carbons in butene.
- d. Cyclobutene has fewer hydrogen atoms than butene.

Answer: D

24. Which is a difference between butyne and cyclobutyne?

- a. Cyclobutyne does not exist.
- b. Butyne's multiple bond is interior, cyclobutyne is not between interior carbons.
- c. Cyclobutyne burns much hotter than butyne because of the greater unsaturation.
- d. Both b and c are differences between the molecules.

Answer: A

25. What is the correct IUPAC name for the compound $\text{CH}_3-\text{C}\equiv\text{C}-\text{CH}_2-\text{CH}_2-\text{Br}$?

- a. 4-bromopentyne
- b. 1-bromo-2-pentyne
- c. 1-bromo-3-pentyne
- d. 5-bromo-2-pentyne

Answer: D

26. The addition of two moles of hydrogen molecules (H_2) to an alkyne produces an:

- a. alkane.
- b. alkene.
- c. aromatic.
- d. alkyl halide.

Answer: A

27. What is the product of the following reaction? CH_3

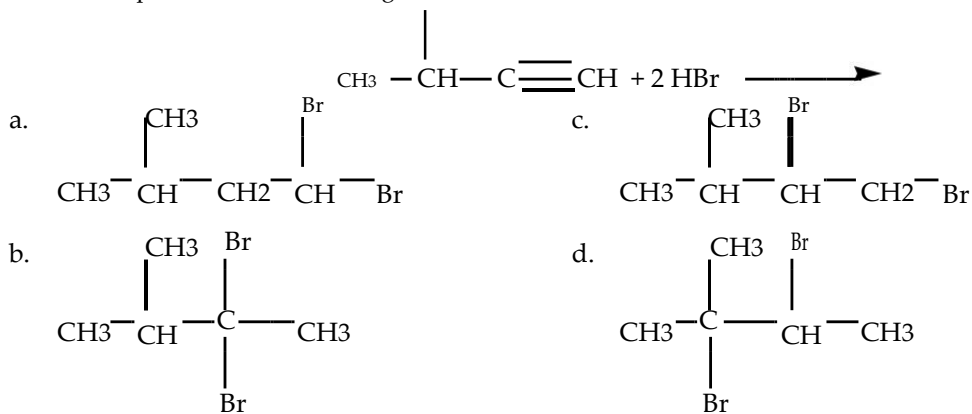

Answer: B

28. Acetylene is commercially useful as a fuel for torches and as:

- a starting material for plastics.
- an industrial solvent.
- an ingredient in pesticides.
- a component in paint formulations.

Answer: A

29. What is the characteristic of aromatic compounds that is responsible for them being named aromatic compounds?

- The compounds have a pleasant smell.
- These compounds contain a benzene ring or structural relative.
- A requirement is to contain a hydrocarbon chain that is either saturated or unsaturated and at least 3 carbons long.
- There is more than one correct response.

Answer: B

30. Which of the following compounds is not considered to be aromatic?

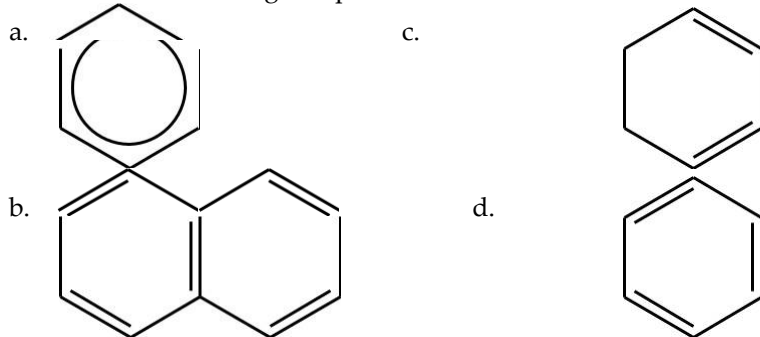

Answer: C

31. Which of the following structures violates the octet rule?

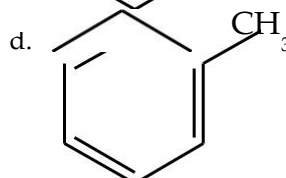
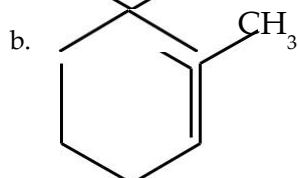
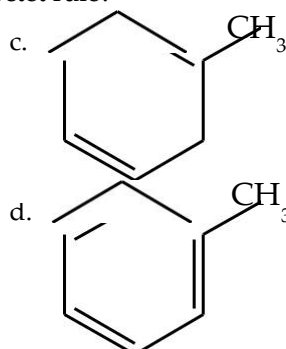
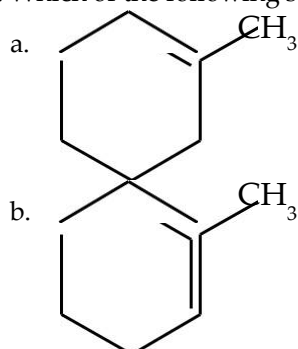

Answer: B

32. The benzene ring as a branch is called:

- a. hexyl. b. benzyl. c. phenol. d. phenyl.

Answer: D

33. What is a correct name for the compound,

- a. 2-chlorophenol
b. 2-chlorotoluene

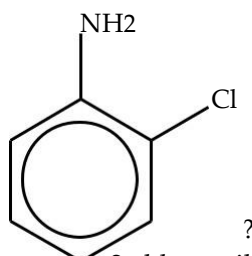

- c. 2-chloroaniline
d. 1-chloroaniline

Answer: C

34. What is the correct name for the compound,

- a. 3-phenyl-1-propene
b. 1-phenyl-1-propene

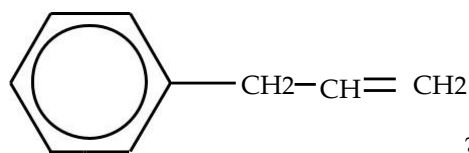

- c. 1-phenyl-2-propene
d. 3-phenyl-2-propene

Answer: A

35. Another acceptable name for 1-ethyl-3-methylbenzene is:

- a. *m*-ethylmethyltoluene. c. *p*-ethylmethyltoluene.
b. *o*-ethylmethyltoluene. d. *m*-ethyltoluene.

Answer: D

36. A major source of aromatic compounds is:

- a. coal tar. b. plants. c. animals. d. soils.

Answer: A

37. Which of the following is a useful organic solvent?

- a. aniline b. toluene c. naphthalene d. phenacetin

Answer: B

38. Naphthalene is used as a(n):
 a. explosive. b. moth repellent. c. pain reliever. d. solvent.

Answer: B

39. Identify the statement about lycopene that is true.
 a. Lycopene is known as vitamin C.
 b. Lycopene gives watermelon their red color.
 c. Raw tomatoes are a better source of lycopene than cooked tomatoes.
 d. Lycopene should not be eaten with fatty foods.

Answer: B

40. Which of the following is true?
 a. Alkynes are not flammable, the others hydrocarbons are flammable.
 b. Alkenes all have a scent similar to the aromatic compounds, but the alkanes and alkynes have a scent that is extremely sharp.
 c. Alkanes have only single bonds between carbons.
 d. There is more than one correct response.

Answer: C

41. Name the following compound.

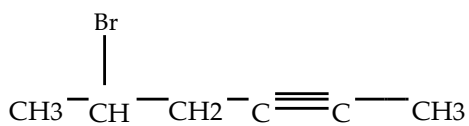

- a. 5-bromo-2-hexyne c. bromo-4-hexyne
 b. 1-bromo-1-methyl-3-pentyne d. none of these are correct

Answer: A

42. Name the following aromatic compound.

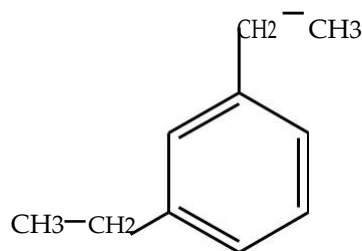

- a. 1,5-diethylbenzene c. o-diethylbenzene
 b. p-diethylbenzene d. 1,3-diethylbenzene

Answer: D

43. How many of the following compounds are possible?

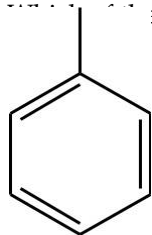

1

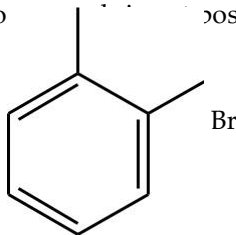

2

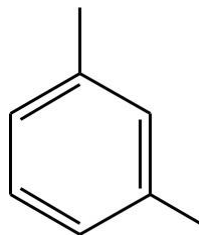

3

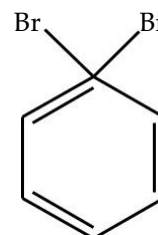

4

- a. 1

- b. 2

- c. 3

- d. 4

D

44. Poly (vinyl chloride), PVC, is used for water pipes and synthetic leather. What is the monomer of the PVC polymer shown on the right?

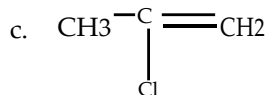
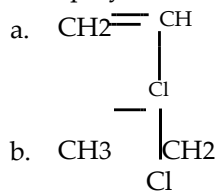

d. none of the above

Answer: A

45. Lycopene has been shown to prevent certain types of cancer. Which of the following is not a good source of lycopene?

- a. tomatoes
 b. pink grapefruit
 c. guava
 d. green beans

Answer: D

46. The reaction of hydrogen fluoride with ethene would be an example of:

- a. hydration.
 b. halogenation.
 c. hydrohalogenation.
 d. fluorination.

Answer: C

47. Which of the following could exhibit cis/trans isomerism?

- a. propene
 b. 1,1-dichloropropene
 c. 1-butene
 d. 2-butene

Answer: D

48. What type of hybridization is associated with alkyne bonding?

- a. sp
 b. sp^2
 c. sp^3
 d. sp^4

Answer: A

TRUE-FALSE

1. $\text{CH}_3\text{CH}_2\text{CH}_2\text{CH}_2$ is the formula for a saturated hydrocarbon.

Answer: F

2. The general formula for an alkene is C_nH_{2n} .

Answer: T

3. Alkenes must have at least two carbon atoms.

Answer: T

4. Alkenes have a maximum of one double bond.

Answer: F

5. The addition of bromine to an alkene results in an alkane because one bond of the multiple bond is broken.

Answer: T

6. A characteristic of alkynes is a region of strong polarity caused by the multiple bond.

Answer:F

7. One of the halogenation reactions occurs when a halogen, a member of group VIIA, reacts with alkene.

Answer: T

8. Cyclic compounds do not undergo halogenation reactions.

Answer: F

9. The general formula for an alkyne is C_nH_{2n} .

Answer:F

10. Markovnikov's rule indicates that in the addition of H-X to an alkene, the hydrogen becomes attached to the carbon atom that is already bonded to more hydrogens.

Answer: T

11. An alkene with one multiple bond can be converted to an alkane by hydration.

Answer:T

12. Polymers are compounds that are composed of repeating units chemically bound to each other.

Answer: T

13. The physical properties of alkynes are very different from those of alkenes.

Answer:F

14. 2-butyne can exist as *cis*- and *trans*- isomers.

Answer:F

15. The same substances which add to double bonds can add to triple bonds.

Answer:T

16. Two moles of hydrogen gas would be required to convert one mole of 2-butyne into butane.

Answer: T

17. Benzene is not an alkene.

Answer:T

18. Phenyl is the name given to a benzene ring that is an attached group to a larger molecule.

Answer: T

19. Aromatic compounds dissolve well in a nonpolar solvent.

Answer:T

20. The alkynes belong to an extensive family of compounds that have a large biological significance, especially when discussing digestion.

Answer: F