

Solution Manual for Basic Technical Mathematics 10th Edition by Washington ISBN 0133083500 9780133083507

Solution Manual

<https://testbankpack.com/p/solution-manual-for-basic-technical-mathematics-10th-edition-by-washington-isbn-0133083500-9780133083507/>

Test Bank

<https://testbankpack.com/p/test-bank-for-basic-technical-mathematics-10th-edition-by-washington-isbn-0133083500-9780133083507/>

Chapter 2

GEOMETRY

2.1 Lines and Angles

1. $\angle ABE = 90^\circ$

2. $\angle QOR = 90^\circ - 32^\circ = 58^\circ$

3. 4; $\angle BOC$ and $\angle COA$,
 $\angle COA$ and $\angle AOD$,

$\angle AOD$ and $\angle DOB$,

and, $\angle DOB$ and $\angle BOC$.

4. (a) $\frac{7.75}{5.65} = \frac{x}{6.50}$
 $7.75(6.50)$

$x = \underline{\hspace{2cm}}$

5.65

$x = 8.92 \text{ ft}$

(b) More vertical

5. $\angle EBD$ and $\angle DBC$ are acute angles.

6. $\angle ABE$ and $\angle CBE$ are right angles.

7. $\angle ABC$ is a straight angle.

8. $\angle ABD$ is an obtuse angle.

15. $\angle BOD = 180^\circ - 90^\circ - 50^\circ = 40^\circ$

16. $\angle 3 = 180^\circ - 35^\circ = 145^\circ$

17. $\angle 1 = 180^\circ - 145^\circ = 35^\circ = \angle 2 = \angle 4$

18. $\angle 5 = \angle 3 = 145^\circ$ 19. $\angle 1^\circ = 62^\circ$

20. $\angle 2 + \angle 1 = 180^\circ \Rightarrow \angle 2 = 180^\circ - \angle 1$

$= 180 - 62 = 118$

21. $\angle 3 = 90^\circ - 62^\circ = 28^\circ$

22. $\angle 1 + \angle 3 = 90^\circ$ $\angle 3 + \angle 4 = 180^\circ$

$\angle 3 = 90 - 62$ $\angle 4 = 180$

$\angle 3 = 28^\circ$ $= 180^\circ$

$\angle 4 = 152^\circ$

23. $\angle BDE = 90^\circ - 44^\circ = 46^\circ$
 $\angle BDF = 180^\circ - 46^\circ = 134^\circ$

24. $\angle BDE = 90^\circ - 44^\circ = 46^\circ$
 $\angle ABE = 90^\circ + 46^\circ = 136^\circ$

25. $\angle DEB = 44^\circ$

9. The complement of $\angle CBD = 65^\circ$ is 25° .

26. $\angle DBE = 46^\circ$

10. The supplement of $\angle CBD = 65^\circ$ is

$$180^\circ - 65^\circ = 115^\circ.$$

11. Sides BD and BC are adjacent to $\angle DBC$

12. The angle adjacent to $\angle DBC$ is $\angle DBE$

13. $\angle AOB = 90^\circ + 50^\circ = 140^\circ$

14. $\angle AOC = 90^\circ - 50^\circ = 40^\circ$

27. $\angle DFE = 90^\circ - \angle FDE$

$$= 90^\circ - 44^\circ$$

$$= 46^\circ$$

28. $\angle ADE = \angle ADB + 90^\circ$

$$= (90^\circ - 44^\circ) + 90^\circ$$

$$= 136^\circ$$

29. $\frac{a}{4.75} = \frac{3.05}{3.20} \Rightarrow a = 4.75 \cdot \frac{3.05}{3.20} = 4.53 \text{ m}$

30. $\frac{3.20}{3.05} = \frac{6.25}{b}$

$b = 5.96 \text{ m}$

31. $\frac{c}{3.05} = \frac{5.50}{4.53} = \frac{5.50}{4.53}$

$4.53c = 15.4025$

$c = 3.40 \text{ m}$

32. $\frac{4.75}{5.05} = \frac{6.25}{d}$

$d = 6.64 \text{ m}$

33. $\angle BHC = \angle CGD = 25^\circ$

34. $\angle AHC = \angle CGE = 45^\circ$

35. $\angle BCH = \angle CHG = \angle HGC = \angle GCD = 65^\circ$

36. $\angle HAB = \angle JHA = \angle FGE = \angle DEG = 70^\circ$

37. $\angle GHA = \angle HGE = 110^\circ$

38. $\angle CGF = \angle CHJ = 115^\circ$

39. $\angle A = (x+10)^\circ, \angle B = (4x-5)^\circ$

(a) $x+10 = 4x-5$

$x = 5^\circ$

(b) $x+10+4x-5 = 180$

$x = 35^\circ$

40. $\angle A = (x+20)^\circ, \angle B = (3x-2)^\circ$

(a) $x+20+3x-2 = 90^\circ$

$x = 18^\circ$

(b) $x+20 = 3x-2$

$x = 11^\circ$

41. $\angle BCD = 180^\circ - 47^\circ$

$= 133^\circ$

43. $\frac{2}{2.15} = \frac{3}{AB} \Rightarrow AB = 3.225$

$AC = 2.15 + 3.23 = 5.38 \text{ cm}$

44. $\frac{x}{860} = \frac{590}{550}$

$x = 920 \text{ m}$

45. $\angle 1 + \angle 2 + \angle 3 = 180^\circ$,

($\angle 1, \angle 2,$ and $\angle 3$ form a straight line)

46. $\angle 4 + \angle 2 + \angle 5 = 180^\circ, (\angle 1 = \angle 4, \angle 3 = \angle 5)$

47. The sum of the angles of $\triangle ABD$ is 180° .

48.

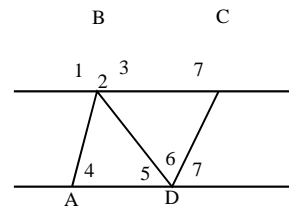

$\angle 1 + \angle 2 + \angle 3 = 180^\circ, \angle 1 = \angle 4$

$\angle 4 + \angle 2 + \angle 3 = 180^\circ$

$\angle 5 + \angle 6 + \angle 7 = 180^\circ$

$\angle 4 + (\angle 2 + \angle 3) + (\angle 5 + \angle 6) + \angle 7 = 180 + 180$

$= 360$

The sum of the angles of $\triangle ABD = 360^\circ$

42. $? = 90^\circ - 28^\circ$

$$= 62^\circ$$

2.2 Triangles

1. $\angle 5 = 45^\circ \Rightarrow \angle 3 = 45^\circ$
 $\angle 2 = 180^\circ - 70^\circ - 45^\circ = 65^\circ$

2. $A = \frac{1}{2}bh = \frac{1}{2}(61.2)(5.75)$

$A = 176 \text{ in.}^2$

3. $AC^2 = AB^2 + BC^2$
 $= 6.25^2 + 3.2^2$

$AC = \sqrt{6.25^2 + 3.2^2}$

$AC = 7.02 \text{ m}$

4. $\frac{h}{3.0} = \frac{24}{4.0}$
 $h = 18 \text{ ft}$

5. $\angle A = 180^\circ - 84^\circ - 40^\circ = 56^\circ$

6. $\angle A = 90^\circ - 48^\circ = 42^\circ$

7. This is an isosceles triangle, so the base angles are equal. $\angle A = 180^\circ - (66^\circ + 66^\circ) = 48^\circ$

8. $\angle A = \frac{1}{2}(180 - 110) = 35^\circ$

9. $A = \frac{1}{2}bh = \frac{1}{2}(7.6)(2.2) = 8.4 \text{ ft}^2$

10. $A = \frac{1}{2}bh = \frac{1}{2}(16.0)(7.62) = 61.0 \text{ mm}^2$

12. $p = 0.862 + 0.235 + 0.684 = 1.781 \text{ in.}$

$s = \frac{1.781}{2} = 0.8905$

$A = \sqrt{s(s-a)(s-b)(s-c)}$

$= \sqrt{.8905(.8905 - .862)(.8905 - .235)(.8905 - .684)}$

$A = 0.586 \text{ in.}^2$

13. $A = \frac{1}{2}bh = \frac{1}{2}(3.46)(2.55) = 4.41 \text{ ft}^2$

14. $A = \frac{1}{2}bh = \frac{1}{2}(234)(342) = 40,000 \text{ mm}^2$

15. Area

$= \sqrt{1.428(1.428 - 0.9860)(1.428 - 0.986)$
 $\sqrt{(1.428 - 0.884)}$

$= 0.390 \text{ m}^2$

16. $s = \frac{3(320)}{2} = 480$

$A = \frac{1}{2} \sqrt{s(s-a)^3}$
 $= \frac{1}{2} \sqrt{480(480 - 320)^3}$

$= 44,000 \text{ yd}^2$

17. $p = 205 + 322 + 415$
 $p = 942 \text{ cm}$

18. $p = 23.5 + 86.2 + 68.4$
 $p = 178 \text{ in.}$

$$\begin{aligned} 11. \text{ Area} &= 4\sqrt{\frac{2}{2}(471-205)(471-415)(471-322)}} \\ &= 32,300 \text{ cm}^2 \end{aligned}$$

$$19. 3(21.5) = 64.5 \text{ cm}$$

$$20. \text{ Perimeter} = 2(2.45) + 3.22 = 8.12 \text{ in.}$$

$$21. c = \sqrt{13.8^2 + 22.7^2} = 26.6 \text{ ft}$$

$$22. c^2 = a^2 + b^2$$

$$= 2.48^2 + 1.45^2$$

$$c = 2.87 \text{ m}$$

$$23. b = \sqrt{551^2 - 175^2} = 522 \text{ cm}$$

24. $c^2 = a^2 + b^2$
 $0.836^2 = a^2 + 0.474^2$
 $a = 0.689$ in.

25. $\angle B = 90^\circ - 23^\circ = 67^\circ$

26. $c^2 = 90.5^2 + 38.4^2$
 $c = 98.3$ cm

27. Perimeter = $98.3 + 90.5 + 38.4 = 227.2$ cm

28. $A = \frac{1}{2}(90.5)(38.4) = 1740$ cm²

29.

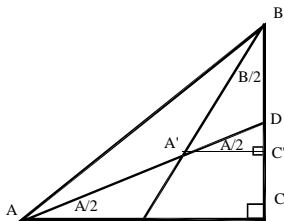

$\triangle ADC \sim \triangle A'DC' \Rightarrow \angle DA'C' = A/2$

\angle between bisectors = $\angle BA'D$
 $\triangle BA'C', \frac{B}{2} + (\angle BA'D + A/2) = 90^\circ$

from which $\angle BA'D = 90^\circ - \left(\frac{A}{2} + \frac{B}{2}\right)$

or $\angle BA'D = 90^\circ - \left(\frac{A+B}{2}\right) = 90^\circ - \frac{90^\circ}{2} = 45^\circ$

30.

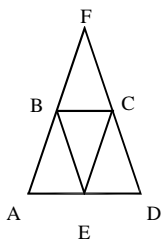

$\angle A = \angle D$ since $\triangle AFD$ is isosceles. Since $AF = FD$ ($\triangle AFD$ is isosceles) and since B and C are mid-points, $AB = CD$ which means $\triangle BAE$ and $\triangle CED$ are the same size and shape. Therefore, $BE = EC$ from which it follows that the inner $\triangle BCE$ is isosceles.

31. An equilateral triangle.

32. Yes, if one of the angles of the triangle is obtuse.

33.

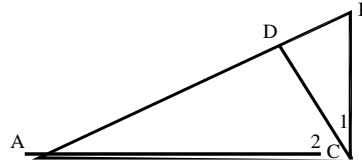

$\angle A + \angle B = 90^\circ$
 $\angle 1 + \angle B = 90^\circ$
 $\Rightarrow \angle A = \angle 1$

redraw $\triangle BDC$ as

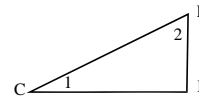

$\angle 1 + \angle 2 = 90^\circ$
 $\angle 1 + \angle B = 90^\circ$
 $\Rightarrow \angle 2 = \angle B$

and $\triangle ADC$ as

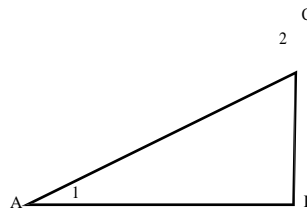

$\triangle BDC$ and $\triangle ADC$ are similar.

34. Comparing the original triangle

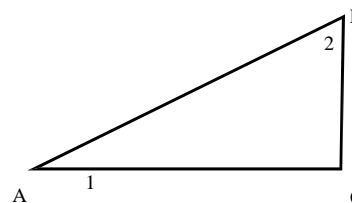

to the two smaller triangles shows that all three are similar.

35. $\angle LMK$ and $\angle OMN$ are vertical angles and thus equal $\Rightarrow \angle KLM = \angle MON$. The corresponding angles are equal and the triangles are similar.

36. $\angle ACB = \angle ADC = 90^\circ$; $\angle A = \angle A$; $\angle DCA = \angle CBA$,
therefore $\triangle ACB \sim \triangle ADC$

37. Since $\triangle MKL \sim \triangle MNO$; $KN = KM - MN$; $15 - 9 = 6$
 $= KM$; $\frac{KM}{LM} = \frac{LM}{LM}$; $\frac{6}{LM} = \frac{LM}{LM}$; $9LM = 72$; $LM = 8$

$$\frac{MN}{MO} = \frac{9}{12}$$

38. $\frac{AB}{12} = \frac{12}{16}$

$$\frac{12}{AB} = \frac{9}{16}$$

39. $p = 6 + 25 + 29 = 60$

$$A = \frac{1}{2}(30 - 6)(30 - 25)(30 - 29) = 60$$

Yes, the triangle is perfect.

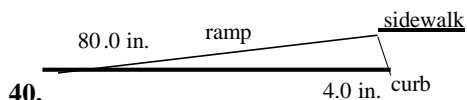

$$\frac{\text{street}}{4.0} = \frac{20.0}{1}$$

$$\Rightarrow \text{street} = 4.0(20.0)$$

$$\text{ramp} = \sqrt{(4.0(20.0))^2 + 4.0^2} = 80.09993758,$$

calculator

ramp = 80 in. (two significant digits)

41. $\angle = \frac{180^\circ - 50^\circ}{2} = 65^\circ$

42. angle between tower and wire = $90^\circ - 52^\circ = 38^\circ$

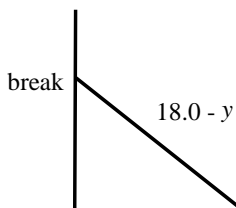
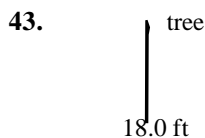
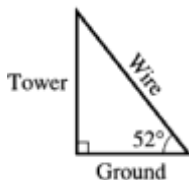

$$(18.0 - y)^2 = y^2 + 8.0^2$$

$$18.0^2 - 2(18.0)y + y^2 = y^2 + 8.0^2$$

$$y = 7.2 \text{ ft (two significant digits)}$$

$$3(1600)$$

44. $\frac{2}{2} = 2400$

$$A = \sqrt{2400(2400 - 1600)^3}$$

$$A = 1,100,000 \text{ km}^2$$

45. $A = \frac{1}{2}bh = \frac{1}{2}(8.0)(15) = 60 \text{ ft}^2$

46. $d = \sqrt{750^2 + 550^2} = 930 \text{ m}$

47.

$$10.0^2 = x^2 + 6.00^2$$

$$x = 8.00$$

$$L = \sqrt{(8.00 + 2.50)^2 + 6.00^2}$$

$$L = 12.09338662, \text{ calculator}$$

$$L = 12.1 \text{ ft (three significant digits)}$$

48. Taking the triangles in clockwise order and using

Pythagorean Theorem together with side opposite

30° angle is half the hypotenuse gives side opposite

30° angle and third side, respectively.

49. $d = \sqrt{18^2 + 12^2 + 8^2} = 23 \text{ ft}$

50. $\frac{x}{45.6} = \frac{1}{1.12}$, $x = 38 \text{ m}$

8.0 ft

51.

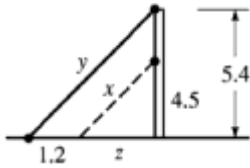

$$\frac{4.5}{z} = \frac{5.4}{1.2 + z}$$

$$z = 1.2 + z$$

$$z = 6.0 \text{ m}$$

$$x^2 = z^2 + 4.5^2$$

$$x = 7.5 \text{ m}$$

$$y^2 = (1.2 + 6)^2 + 5.4^2$$

$$y = 9.0 \text{ m}$$

52.

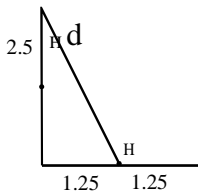

$$d^2 = 1.25^2 + 5.0^2$$

$$d = 5.6 \text{ ft}$$

53.

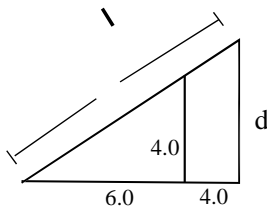

$$\frac{d}{8.0} = \frac{4.0}{6.0} \Rightarrow d = \frac{4.0(8.0)}{6.0}$$

$$l^2 = 8.0^2 + d^2 = 8.0^2 + \left(\frac{4.0(8.0)}{6.0}\right)^2$$

$$l = 9.6 \text{ ft}$$

54. $\frac{ED}{80} = \frac{312}{50}$
 $ED = 499 \text{ ft}$

55. Redraw $\triangle BCP$ as

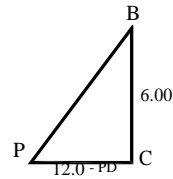

$\triangle APD$ is

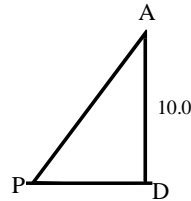

from which $\triangle BCP \sim \triangle ADP$, so $\frac{6.00}{12.0 - PD} = \frac{10.0}{PD}$
 $\Rightarrow PD = 7.50$ and $PC = 12.0 - PD = 4.50$

$$l = PB + PA = \sqrt{4.50^2 + 6.00^2} + \sqrt{7.50^2 + 10.0^2}$$

$$l = 20.0 \text{ mi}$$

56. $\frac{1}{2} wd + 160 = \frac{1}{2} w(d + 16)$

$$\frac{1}{2} wd + 160 = \frac{1}{2} wd + 8w$$

$$8w = 160$$

$$w = 20 \text{ cm}$$

$$d = w - 12 = 8 \text{ cm}$$

2.3 Quadrilaterals

1.

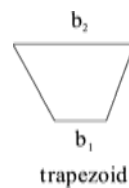

2. $L = 4s + 2w + 2l$

$$= 4(21) + 2(21) + 2(36)$$

$$= 198 \text{ in.}$$

3. $A = \frac{1}{2}bh = \frac{1}{2}(72)(55) = 2000 \text{ ft}^2$

$A_2 = bh = 72(55) = 4000 \text{ ft}^2$

$A_3 = \frac{1}{2}h(b_1 + b_2) = \frac{1}{2}(55)(72 + 35)$
 $= 2900 \text{ ft}^2$

The total lawn area is about 8900 ft^2 .

4. $2(w + 3.0) + 2w = 26.4$

$2w + 6.0 + 2w = 26.4$

$4w = 20.4$

$w = 5.1 \text{ mm}$

$w + 3.0 = 8.1 \text{ mm}$

5. $p = 4s = 4(65) = 260 \text{ m}$

6. $p = 4(2.46) = 9.84 \text{ ft}$

7. $p = 2(0.920) + 2(0.742) = 3.324 \text{ in.}$

8. $p = 2(142) + 2(126) = 536 \text{ cm}$

9. $p = 2l + 2w = 2(3.7) + 2(2.7) = 12.8 \text{ m}$

10. $p = 2(27.3) + 2(14.2) = 83.0 \text{ in.}$

11. $p = 0.362 + 0.730 + 0.440 + 0.612 = 2.144 \text{ ft}$

12. $p = 272 + 392 + 223 + 672 = 1559 \text{ cm}$

13. $A = s^2 = 2.7^2 = 7.3 \text{ mm}^2$

14. $A = 15.6^2 = 243 \text{ ft}^2$

15. $A = 0.920(0.742) = 0.683 \text{ in.}^2$

16. $A = 142(126) = 17,900 \text{ cm}^2$

17. $A = bh = 3.7(2.5) = 9.3 \text{ m}^2$

18. 19.

20. $A = \frac{1}{2}(392 + 672)(201) = 107,000 \text{ cm}^2$

21. $p = 2b + 4a$

22. $p = a + b + b + a + (b - a) + (b - a) = 4b$

23. $b \times h + a^2 = bh + a^2$

24. $A = ab + a(b - a) = 2ab - a^2$

25. The parallelogram is a rectangle.

26. The triangles are congruent. Corresponding sides and angles are equal.

27.

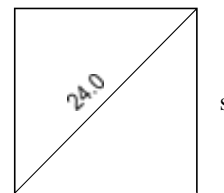

s

$s^2 + s^2 = 24.0^2$

$2s^2 = 24.0^2$

$s^2 = \frac{24.0^2}{2}$

$A = s^2 = 288 \text{ cm}^2$

28.

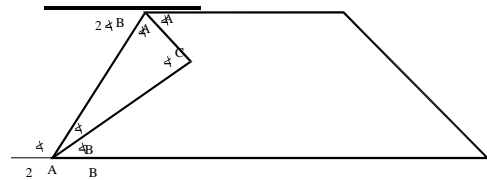

At top $2(B + 2(A = 180^\circ$

$(B + (A = 90^\circ$

$A = 27.3(12.6) = 344 \text{ in.}^2$

$$A = \frac{1}{2} (29.8 + 61.2 + 73.0) = 200 \text{ ft}^2$$

$$\begin{aligned} \angle A + \angle B + \angle C &= 180^\circ \\ 90^\circ + \angle C &= 180^\circ \\ \angle C &= 90^\circ \end{aligned}$$

29.

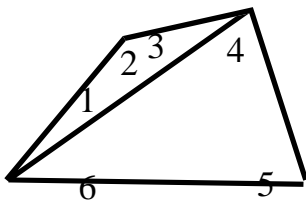

sum of interior angles
 $= (1 + 2 + 3 + 4) + (5 + 6)$
 $= 180^\circ + 180^\circ$
 $= 360^\circ$

30. $S = 180(n - 2)$

(a) $n = \frac{S}{180} + 2$

(b) $n = \frac{3600}{180} + 2$
 $n = 22$

31. $A =$ area of left rectangle + area of right rectangle

$A = ab + ac$

$A =$ area of entire rectangle

$A = a(b + c)$ which illustrates the distributive property.

32. $A = (a + b)(a + b) = (a + b)^2$

$A = ab + ab + a^2 + b^2$

$A = a^2 + 2ab + b^2$ which illustrates that the square

of the sum is the square of the first term plus twice the product of the two terms plus the square of the second term.

33. The diagonal always divides the rhombus into two congruent triangles. All outer sides are always equal.



34. $\sqrt{16^2 + 12^2} = 40 = 20$

35. (a) For the courtyard: $s = \frac{p}{4} = \frac{320}{4} = 80$. For the

36.

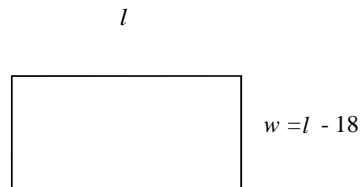

$p = 2l + 2(l - 18) = 180$ from which
 $l = 54$ in.
 $w = l - 18 = 54 - 18$
 $w = 36$ in.

37.

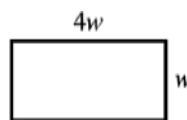

$w + 2.5 = 4w - 4.7$
 $w = 2.4$ ft
 $4w = 9.6$ ft

38. $A = 1.80 \times 3.50 = 6.30$ ft²

39. $A = 2 \left(\frac{1}{2} (28 + 16) \cdot 8 - 12(3.5) \right)$

$= 268$ ft²

1 gal = x

ht of trapezoid

320 ft² = 268 ft²

$x = 0.84$ gal

$= \sqrt{10^2 - \left(\frac{28 - 16}{2} \right)^2}$

$= 8.0$ ft

40.

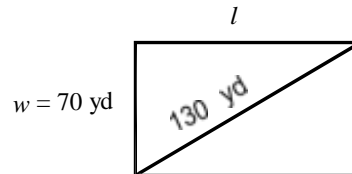

outer edge of the walkway:

$l =$

$$130^2 - 70^2$$

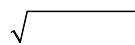

$$p = 4(80 + 6) = 344 \text{ m.}$$

$$(b) A = 86^2 - 80^2 = 996$$

$$A = 1000 \text{ m}^2 \text{ (2 significant digits)}$$

$$p = 2l + 2w$$

$$p = 2\sqrt{30^2 - 70^2} + 2(70)$$

$$p = 360 \text{ yd}$$

41.

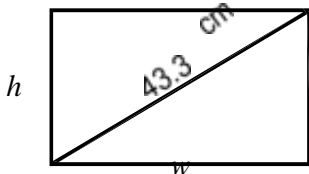

$$\frac{w}{h} = 1.60 \Rightarrow w = 1.60h$$

$$43.3^2 = h^2 + w^2 = h^2 + (1.6h)^2$$

$$h = 22.9 \text{ cm}$$

$$w = 1.60h = 36.7 \text{ cm}$$

42.

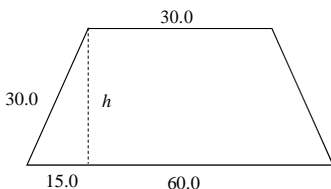

$$h = \sqrt{30.0^2 + 15.0^2}$$

$$A = \frac{1}{2} (30.0 + 60.0) \sqrt{30.0^2 + 15.0^2}$$

$$A = 9060 \text{ in.}^2$$

43.

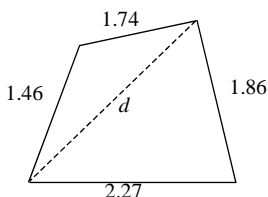

$$d = \sqrt{2.27^2 + 1.86^2}$$

For right triangle, $A = \frac{1}{2} (2.27)(1.86)$

For obtuse triangle, $s = \frac{1.46 + 1.74 + d}{2}$

$$\pi s^2$$

and $A = \sqrt{s(s-1.46)(s-d)(s-1.74)}$

$$A = \frac{1}{2} (2.27)(1.86) + \sqrt{s(s-1.46)(s-d)(s-1.74)}$$

$$A = 3.04 \text{ km}^2$$

44.

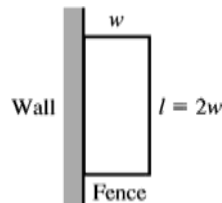

$$50(2w) + 5(2w) + 5w + 5w = 13,200$$

$$w = 110 \text{ m}$$

$$l = 2w = 220 \text{ m}$$

45. 360° . A diagonal divides a quadrilateral into two triangles, and the sum of the interior angles of each triangle is 180° .

$$46. A = \frac{1}{2} d_1 \left(\frac{d_2}{2} \right) + \frac{1}{2} d_1 \left(\frac{d_2}{2} \right)$$

$$A = \frac{1}{2} d_1 d_2$$

2.4 Circles

1. $\angle OAB + \angle OBA + \angle AOB = 180^\circ$

$$\angle OAB + 90^\circ + 72^\circ = 180^\circ$$

$$\angle OAB = 18^\circ$$

2. $A = \pi r^2 = \pi (2.4)^2$

$$A = 18 \text{ km}^2$$

3. $p = 2s + \frac{2\pi s}{4} = 2s + \frac{\pi s}{2}$

$$p = 2(3.25) + \frac{(\quad)}{2}$$

$$p = 11.6 \text{ in.} + \frac{\pi (3.25)}{2}$$

$$A = \frac{\pi (\quad)^2}{4} = \frac{\pi (3.25)^2}{4}$$

Area of quadrilateral = Sum of areas of two triangles,

$$A = 8.30 \text{ in.}$$

$$4. \begin{aligned} AC &= 2 \cdot \angle ABC \\ &= 2(25^\circ) \\ &= 50^\circ \end{aligned}$$

5. (a) AD is a secant line.

(b) AF is a tangent line.

6. (a) EC and BC are chords.
(b) $\angle ECO$ is an inscribed angle.

7. (a) $AF \perp OE$.
(b) $\triangle OCE$ is isosceles.

8. (a) EC and $\overset{\circ}{EC}$ enclose a segment.
(b) radii OE and OB enclose a sector
with an acute central angle.

$$9. c = 2\pi r = 2\pi(275) = 1730 \text{ ft}$$

$$10. c = 2\pi r = 2\pi(0.563) = 3.54 \text{ m}$$

$$11. d = 2r; c = \pi d = \pi(23.1) = 72.6 \text{ mm}$$

$$12. c = \pi d = \pi(8.2) = 26 \text{ in.}$$

$$13. A = \pi r^2 = \pi(0.0952^2) = 0.0285 \text{ yd}^2$$

$$14. A = \pi r^2 = \pi(45.8)^2 = 6590 \text{ cm}^2$$

$$15. A = \pi(d/2)^2 = \pi(2.33/2)^2 = 4.26 \text{ m}^2$$

$$16. A = \frac{1}{4}\pi d^2 = \frac{1}{4}\pi(1256)^2 = 1,239,000 \text{ ft}^2$$

$$17. \angle CBT = 90^\circ - \angle ABC = 90^\circ - 65^\circ = 25^\circ$$

$$\angle ABT = 90^\circ$$

$$\angle CBT = \angle ABT - \angle ABC = 90^\circ - 65^\circ = 25^\circ;$$

$$\angle CAB = 25^\circ$$

20. $\angle BTC = 65^\circ$; $\angle CBT = 35^\circ$ since it is
complementary to $\angle ABC = 65^\circ$.

$$21. \text{ARC BC} = 2(60^\circ) = 120^\circ$$

$$22. \overset{\circ}{BC} = 2(60^\circ) = 120^\circ$$

$$\overset{\circ}{AB} + 80^\circ + 120^\circ = 360^\circ$$

$$\overset{\circ}{AB} = 160^\circ$$

23. $\angle ABC = (1/2)(80^\circ) = 40^\circ$ since the measure of an
inscribed angle is one-half its intercepted arc.

$$24. \angle ACB = \frac{1}{2}(160^\circ) = 80^\circ$$

$$25. 0.22.5 \left(\left| \frac{\pi}{180^\circ} \right| \right) = 0.393 \text{ rad}$$

$$26. 60.0 = 60.0 \cdot \frac{\pi \text{ rad}}{180^\circ} = 1.05 \text{ rad}$$

$$27. 125.2^\circ = 125.2\pi \text{ rad}/180^\circ = 2.185 \text{ rad}$$

$$28. 3230^\circ = 3230 \cdot \frac{\pi \text{ rad}}{180} = 56.4 \text{ rad}$$

$$29. P = \frac{1}{4}(2\pi r + 2r = \frac{\pi r}{2} + 2r$$

$$4 \qquad 2$$

$$30. \text{Perimeter} = a + b + \frac{\pi r}{2} + 2\pi r + r$$

18.

31. Area = $\frac{1}{2} \pi r^2 - \frac{1}{2} r^2$

$\angle B$
 CT

$= 90^\circ$,
 any
 angle **32.**
 such as
 $\angle BCA$
 inscrib
 ed in a
 semicir
 cle is a
 right
 angle
 and
 $\angle BCT$
 is
 supple
 mentar
 y to
 $\angle BCA$.

4
 2
 Ar
 ea
 =
 $\frac{1}{2}$
 $(a$
 $r)$
 $+$
 $\frac{1}{2}\pi$
 r^2
 2
 4

19. A tangent to a circle is perpendicular to the radius drawn to the point of contact. Therefore,

33. All are on the same diameter.

34.

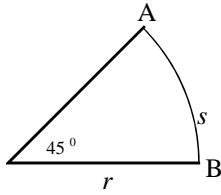

$$AB = 45^\circ$$

$$\frac{s}{2\pi r} = \frac{45}{360}$$

$$s = \frac{\pi}{4} \cdot r$$

$$\frac{\pi}{4}$$

35.

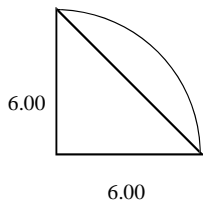

A of sector = A of quarter circle - A of triangle

$$A = \frac{1}{4} \cdot \pi (6.00)^2 - \frac{1}{2} (6.00)(6.00)$$

$$A = 10.3 \text{ in.}^2$$

36. $\angle ACB = \angle DCE$ (vertical angles)

$$\angle BAC = \angle DEC \text{ and}$$

$$\angle ABC = \angle CDE \text{ (alternate interior angles)}$$

Therefore, the triangles are similar since corresponding angles are equal.

37. $c = 2\pi r \Rightarrow \pi = \frac{c}{2r}$; $d = 2r \Rightarrow r = \frac{d}{2}$ from which

$$\pi = \frac{c}{\frac{d}{2}} = \frac{2c}{d}$$

$$\pi = \frac{c}{d} \cdot 2$$

π is the ratio of the circumference to d

39. A

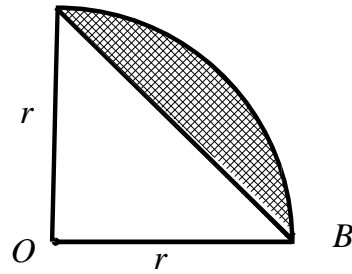

$A_{\text{segment}} = \text{area of quarter circle} - \text{area of triangle}$

$$A_{\text{segment}} = \frac{1}{4}\pi r^2 - \frac{1}{2} \cdot r \cdot r$$

$$A_{\text{segment}} = \frac{r^2(\pi - 2)}{4}$$

40. A

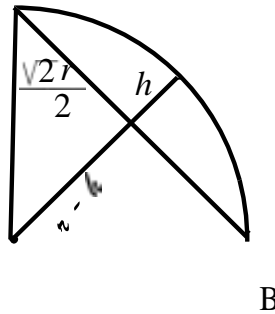

$$\frac{2}{2} = \frac{2}{2}$$

$$AB = r + r$$

$$AB = 2r$$

$$AC = \frac{1}{2} AB = \frac{\sqrt{2}r}{2} \text{ in right triangle OAC}$$

$$r^2 = \left(\frac{\sqrt{2}r}{2}\right)^2 + (r-h)^2 \text{ from which}$$

$$h = \left(\frac{\sqrt{2}r}{2}\right)$$

38.

$$\begin{aligned} \text{dia} \\ \text{me} \end{aligned} \quad 2 - 2r$$

2

ter.

$$\underline{d} \quad \underline{5} \quad \underline{1} \quad \underline{5}$$

41.

$$c = 4 + 4 + 4 + 16$$

$$c = \frac{16}{5}d \Rightarrow \pi = \frac{16}{5} = 3.25$$

which is incorrect since $\pi = 3.14159 \dots$

$h = 11.5$
km

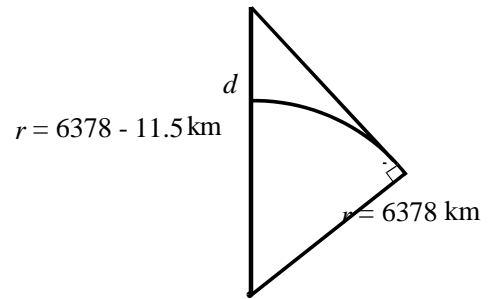

$$(6378 + 11.5)^2 = d^2 + 6378^2$$

$$d = 383 \text{ km}$$

42.

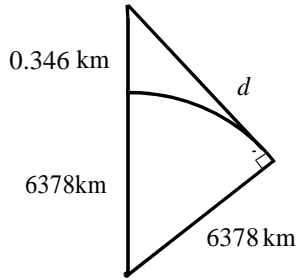

$$(6378 + 0.346)^2 = d^2 + 6378^2$$

$$d = 66.4 \text{ km}$$

43. $d = \sqrt{68^2 + 58^2}$

$$d = 89 > 85$$

68 km

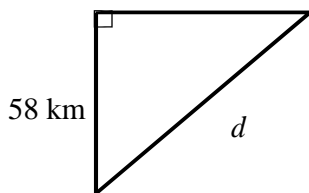

Signal cannot be received.

44. Using $A = \frac{\pi d^2}{4}$,

$$A = \frac{\pi(12.0 + 2(0.60))^2}{4} - \frac{\pi(12.0)^2}{4}$$

$$A = 23.8 \text{ m}^2$$

0.60 m

using $A = \frac{\pi d^2}{4}$,

$$A = \frac{\pi(12.0 + 2(0.60))^2}{4} - \frac{\pi(12.0)^2}{4}$$

$$A = 23.8 \text{ m}^2$$

45. $C = 2\pi r = 2\pi(3960) = 24,900 \text{ mi}$

46. $11(2\pi r) = 109$

$$r = 1.58 \text{ mm}$$

$$\left(\frac{12.0}{2} \right)^2$$

$$\frac{A_{\text{basketball}}}{\pi} = \frac{\pi \left(\frac{12.0}{2} \right)^2}{\pi} = \frac{4}{\pi}$$

47. $A_{\text{hoop}} = \pi \left(\frac{18.0}{2} \right)^2 = 9$

48. $\text{flow rate} = \frac{\text{volume}}{\text{time}} = \frac{\pi r^2 L}{\pi^2 \frac{2\pi r^2}{t}}$

$$2 \text{ flow rate} = \frac{2}{t} = \frac{1}{t}$$

$$t_2^2 = 2 \cdot t_1^2$$

$$t_2 = \sqrt{2} t_1$$

49. $c = 112$; $c = \pi d$; $d = c / \pi = 112 / \pi = 35.7 \text{ in.}$

50. $A = \frac{\pi}{2}(90^2 - 45^2)$

$$A = 9500 \text{ cm}^2$$

51. Let $D =$ diameter of large conduit, then $D = 3d$ where $d =$ diameter of smaller conduit

$$F = \frac{\pi}{4} D^2 = 7 \cdot \frac{\pi}{4} \cdot d^2$$

$$F = \frac{7d^2}{4} = \frac{7d^2}{4} = \frac{7d^2}{4}$$

$$F = \frac{D^2}{9} = \frac{(3d)^2}{9} = \frac{9d^2}{9} = d^2$$

$$d = 12.0 \text{ m}$$

The smaller conduits occupy $\frac{7}{9}$ of the larger

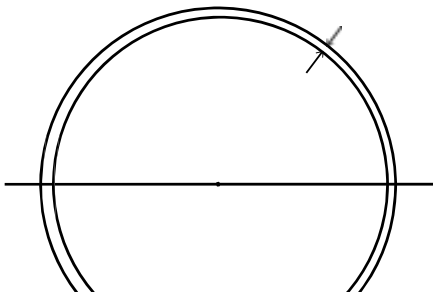

conduits.

52. A of room = A of rectangle + $\frac{3}{4}A$ of circle

$$A = 24(35) + \frac{3}{4}\pi(9.0)^2 = 1030.85174$$

$$A = 1000 \text{ ft}^2, \text{ two significant digits}$$

53. Length = $(2)^{\frac{3}{4}}(2\pi)(5.5) + (4)(5.5) = 73.8 \text{ in.}$

54. $d = 4 \cdot \frac{\sqrt{12.5^2 - 2.25^2}}{2\pi}$

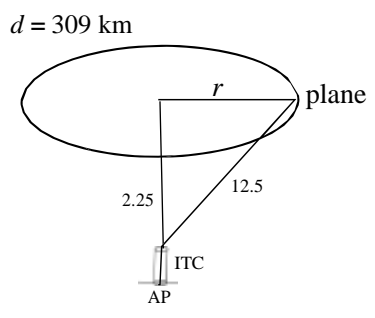

55. Horizontally and opposite to original direction

56. Let A be the left end point at which the dashed lines intersect and C be the center of the gear. Draw a line from C bisecting the 20° angle. Call

the intersection of this line and the extension of the upper dashed line B , then

$$\frac{360}{24 \text{ teeth}} = 15 \Rightarrow \angle ACB = 7.5^\circ$$

$$\angle ABC = 180^\circ - \frac{20^\circ}{2} = 170^\circ$$

$$\angle \frac{1}{2}x + \angle ABC + \angle ACB = 180^\circ$$

$$\frac{1}{2}x + 170^\circ + 7.5^\circ = 180^\circ$$

2.5 Measurement of Irregular Areas

1. The use of smaller intervals improves the approximation since the total omitted area or the total extra area is smaller.
2. Using data from the south end gives five intervals. Therefore, the trapezoidal rule must be used since Simpson's rule cannot be used for an odd number

of intervals.

3. Simpson's rule should be more accurate in that it accounts better for the arcs between points on the upper curve.
4. The calculated area would be too high since each trapezoid would include more area than that under the curve.

5. $A_{\text{trap}} = \frac{2.0}{2} [0.0 + 2(6.4) + 2(7.4) + 2(7.0) + 2(6.1)$

$$+ 2(5.2) + 2(5.0) + 2(5.1) + 0.0]$$

$$A_{\text{trap}} = 84.4 = 84 \text{ m}^2 \text{ to two significant digits}$$

6. A_{simp}

$$= \frac{h}{3} (y_0 + 4y_1 + 2y_2 + 4y_3 + \dots + 2y_{n-2} + 4y_{n-1} + y_n)$$

$$= \frac{2.0}{3} (0 + 4(6.4) + 2(7.4) + 4(7.0) + 2(6.1) + 4(5.2)$$

$$+ 2(5.0) + 4(5.1) + 0) = 88 \text{ m}^2$$

7. $A_{\text{simp}} = \frac{1.00}{3} (0 + 4(0.52) + 2(0.75) + 4(1.05)$

$$+ 2(1.15) + 4(1.00) + 0.62) = 4.9 \text{ ft}^2$$

2

$$\angle \frac{1}{x} = 2.5^\circ$$

2

$$x = 5^\circ$$

$$\begin{aligned} \mathbf{8.} \quad A_{\text{trap}} &= \frac{1}{2} (0 + 2(0.52) + 2(0.75) + 2(1.05) + 2(1.15) \\ &\quad + 2(1.00) + 0.62) = 4.8 \text{ ft}^2 \end{aligned}$$

$$\begin{aligned} \mathbf{9.} \quad A_{\text{trap}} &= \frac{0.5}{2} [0.6 + 2(2.2) + 2(4.7) + 2(3.1) + 2(3.6) \\ &\quad [+ 2(1.6) + 2(2.2) + 2(1.5) + 0.8] \\ A_{\text{trap}} &= 9.8 \text{ m}^2 \end{aligned}$$

$$10. A_{\text{simp}} = \frac{0.5}{3} (0.6 + 4(2.2) + 2(4.7) + 4(3.1) + 2(3.6) + 4(1.6) + 2(2.2) + 4(1.5) + 0.8)$$

$$= 9.3 \text{ mi}^2$$

$$11. A = \frac{10}{2} (38 + 2(24) + 2(25) + 2(17) + 2(34) + 2(29) + 2(36) + 2(34) + 30)$$

$$A = 2330 \text{ mm}^2 \left(\frac{23^2 \text{ km}^2}{10^2 \text{ mm}^2} \right)$$

$$A = 12,000 \text{ km}^2$$

$$12. A = 2 \cdot \frac{4.0}{2} [2(55.0) + 2(2(54.8)) + 2(2(54.0)) + 2(2(53.6)) + 2(2(51.2)) + 2(2(49.0)) + 2(2(45.8)) + 2(2(42.0)) + 2(2(37.2)) + 2(2(31.1)) + 2(2(21.7)) + 2(0.0)]$$

$$A = 7500 \text{ m}^2$$

$$13. A_{\text{trap}} = \frac{45}{2} [170 + 2(360) + 2(420) + 2(410) + 2(390) + 2(350) + 2(330) + 2(290) + 230]$$

$$A_{\text{trap}} = 120,000 \text{ ft}^2$$

$$14. A_{\text{simp}} = \frac{45}{3} (230 + 4(290) + 2(330) + 4(340) + 2(390) + 4(410) + 2(420) + 4(360) + 170)$$

$$= 120,000 \text{ ft}^2$$

$$15. A_{\text{simp}} = \frac{50}{3} (5 + 4(12) + 2(17) + 4(21) + 2(22) + 4(25) + 2(26) + 4(16) + 2(10) + 4(8) + 0)$$

$$= 8100 \text{ ft}^2$$

$$17. A_{\text{trap}} = \frac{0.500}{2} [0.0 + 2(1.732) + 2(2.000) + 2(1.732) + 0.0] = 2.73 \text{ in.}^2$$

This value is less than 3.14 in.² because all of the trapezoids are inscribed.

$$18. A_{\text{trap}} = \frac{0.250}{2} (0.000 + 2(1.323) + 2(1.732) + 2(1.936) + 2(2.000) + 2(1.936) + 2(1.732) + 2(1.323) + 0.000)$$

$$= 3.00 \text{ in.}^2$$

The trapezoids are small so they can get closer to the boundary.

$$19. A_{\text{simp}} = \frac{0.500}{3} (0.000 + 4(1.732) + 2(2.000) + 4(1.732) + 0.000)$$

$$= 2.98 \text{ in.}^2$$

The ends of the areas are curved so they can get closer to the boundary.

$$20. A_{\text{simp}} = \frac{0.250}{3} (0.000 + 4(1.323) + 2(1.732) + 4(1.936) + 2(2.000) + 4(1.936) + 2(1.732) + 4(1.323) + 0.000)$$

$$= 3.08 \text{ in.}^2$$

The areas are smaller so they can get closer to the boundary.

$$\begin{aligned} 16. A_{\text{trap}} &= \frac{1}{2} (3.5 + 2(6.0) + 2(7.6) + 2(10.8) + 2(16.2) \\ &\quad + 2(18.2) + 2(19.0) + 2(17.8) + 2(12.5) \\ &\quad + 8.2) \\ &= 229 \text{ in.}^2 \end{aligned}$$

$$A_{\text{circle}} = \pi r^2 = \pi (d / 2)^2 = \pi (2.5 / 2)^2 = 4.9 \text{ in.}^2$$

$$A_{\text{total}} = 229 - 2(4.9) = 219 \text{ in.}^2$$

2.6 Solid Geometric Figures

1. $V_1 = lwh_1, V_2 = (2l)(w)(2h) = 4lwh = 4V_1$
The volume is four times as much.

2. $s^2 = r^2 + h^2$
 $17.5^2 = 11.9^2 + h^2$
 $h = 12.8 \text{ cm}$

3. $V = \frac{1}{3}\pi r^2 h = \frac{1}{3}\pi \left(\frac{11.9}{2}\right)^2 (2(10.4))$

4. $V = \pi (40.0)^2 \left(\frac{122}{2}\right) + \frac{2}{3}\pi (40.0)^3$

$V = 441,000 \text{ ft}^3$

5. $V = e^3 = 7.15^3 = 366 \text{ ft}^3$

6. $V = \pi r^2 h = \pi (23.5)^2 (48.4) = 84,000 \text{ cm}^3$

7. $A = 2\pi r^2 + 2\pi rh = 2\pi (689)^2 + 2\pi (689)(233)$
 $= 3,990,000 \text{ mm}^2$

8. $A = 4\pi r^2 = 4\pi (0.067)^2 = 0.056 \text{ in.}^2$

9. $V = \frac{4}{3}\pi r^3 = \frac{4}{3}\pi (877^3) = 2.83 \text{ yd}^3$

10. $V = \frac{1}{3}\pi r^2 h = \frac{1}{3}\pi (25.1)^2 (5.66) = 3730 \text{ m}^3$

15. $S = \frac{1}{2}ps = \frac{1}{2}(3 \times 1.092)(1.025) = 3.358 \text{ m}^2$

16. $S = 2\pi rh = 2\pi (d/2)h = 2\pi (250/2)(347)$
 $= 273,000 \text{ ft}^2$

17. $V = \frac{1}{3}\pi r^3 = \frac{1}{3}\pi \left(\frac{0.83}{2}\right)^3 = 0.15 \text{ yd}^3$

18. $b = \frac{22.4}{2} = 11.2; h = \sqrt{\frac{22.4^2}{2} - 11.2^2} = \sqrt{14.2^2 - 11.2^2}$
 $= 8.73 \text{ m}$

$V = \frac{1}{3}Bh = \frac{1}{3}(22.4)^2 (8.73) = 1460 \text{ m}^3$

19. $s = \sqrt{h^2 + r^2} = \sqrt{0.274^2 + 3.39^2} = 3.40 \text{ cm}$

$A = \pi r^2 + \pi rs = \pi (3.39)^2 + \pi (3.39)(3.40)$
 $= 72.3 \text{ cm}^2$

20. There are four triangles in this shape.

$s = \sqrt{3.67^2 - \left(\frac{3.67}{2}\right)^2} = 3.18, A = \frac{1}{2}ps$
 $= \frac{1}{2}(4 \times 3.67)(3.18) = 23.3 \text{ in.}^2$

21. $V = \frac{4}{3}\pi r^3 = \frac{4}{3}\pi \left(\frac{d}{2}\right)^3 = \frac{4}{3}\pi \frac{d^3}{8}$
 $V = \frac{1}{6}\pi d^3$

22. $A = A_{\text{flat}} + A_{\text{curved}}$
 $= \pi r^2 + \frac{1}{2} \cdot 4\pi r^2$

$$11. S = \pi r s = \pi (78.0)(83.8) = 20,500 \text{ cm}^2 \qquad = 3\pi r^3$$

$$12. S = \frac{1}{2} p s = \frac{1}{2} (345)(272) = 46,900 \text{ ft}^2$$

$$23. \text{cylinder} = \frac{(\quad)^2}{2} =$$

$$\frac{2}{3} \times \frac{2}{3}$$

$$13. V = \frac{1}{3} Bh = \frac{1}{3} (0.76^2) (1.30) = 0.25 \text{ in.}^3$$

$$14. V = Bh = (29.0)^2 (11.2) = 9420 \text{ cm}^3$$

$$V = \pi r^2 \frac{h}{6}$$

$$V_{\text{cone}} = \frac{1}{3} \pi r^2 h$$

$$24. \pi r^2 = \frac{1}{4}(\pi r^2 + \pi rs)$$

$$4r^2 = r^2 + rs$$

$$3r^2 = rs$$

$$\frac{r}{s} = \frac{1}{3}$$

$$25. \frac{\text{final surface area}}{\text{original surface area}} = \frac{4\pi(2r)^2}{4\pi r^2} = \frac{4}{1}$$

$$26. 62.4 \frac{\text{lb}}{\text{ft}^3} \cdot 1 \text{ mi}^2 \cdot \frac{5280 \text{ ft}}{12 \text{ in.}} \cdot \frac{\text{ft}}{1 \text{ in.}}$$

$$= 1.45 \times 10^8 \text{ lb} \cdot \frac{\text{ton}}{2000 \text{ lb}}$$

$$= 72,500 \text{ ton}$$

$$27. A = 2lh + 2lw + 2wh$$

$$= 2(12.0)(8.75) + 2(12.0)(9.50) + 2(9.50)(8.75)$$

$$A = 604 \text{ in.}^2$$

$$28. V_1 = 50.0 \times 78.0 \times 3.50 = 13,650 \text{ ft}^3$$

$$V_2 = \frac{1}{2} \times 78.0 \times 5.00 \times 50.0 = 9750 \text{ ft}^3$$

$$V = V_1 + V_2 = 13,650 + 9750 = 23,400 \text{ ft}^3$$

$$29. V = \pi r^2 h = \pi (d/2)^2 h = \pi (4.0/2)^2 (3,960,000)$$

$$= 5.0 \times 10^7 \text{ ft}^3 \text{ or } 0.00034 \text{ mi}^3$$

$$30. V = \frac{1}{3}h(a^2 + ab + b^2)$$

$$= \frac{1}{3}(0.750)(2.50^2 + 2.50(3.25) + 3.25^2)$$

$$= 6.23 \text{ m}^3$$

$$34. s = \sqrt{h^2 + r^2} = \sqrt{3.50^2 + 1.80^2} = 3.94 \text{ in.}$$

$$S = \pi rs = \pi (1.80)(3.94) = 22.3 \text{ in.}$$

$$35. V = \frac{4}{3}\pi r^3 = \frac{4}{3}\pi (d/2)^3$$

$$= \frac{4}{3}\pi (165/2)^3$$

$$= 2.35 \times 10^6 \text{ ft}^3$$

$$36. V = \frac{4}{3}\pi r^3 + \pi r^2 h$$

$$= \frac{4}{3}\pi (2.00)^3 + \pi (2.00)^2 (6.5)$$

$$= 115 \text{ ft}^3$$

$$37. A = l^2 + \frac{1}{2}ps = 16^2 + \frac{1}{2}(4)(16)\sqrt{8^2 + 40^2}$$

$$= 1560 \text{ mm}^2$$

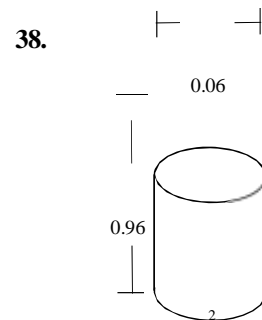

$$N = \pi \left(\frac{0.06}{2} \right) (0.96) = 76$$

$$N = 280 \text{ revolutions}$$

$$39. c = 2\pi r = 29.8 \Rightarrow r = \frac{29.8}{2\pi}$$

31. $\sqrt{\quad} (\quad)$
 $V = 1.80 \sqrt{3.93^2 - 1.80^2} \cdot 1.50 = 9.43 \text{ ft}^3$

$$V = \frac{4}{3} \pi r^3 = \frac{4}{3} \pi \left(\frac{29.8}{2\pi} \right)^3$$

32. There are three rectangles and two triangles in this shape.

$$V = 447 \text{ in.}^3$$

$$A = 2 \left(\frac{1}{2} (3.00)(4.00) + 3.00(8.50) + 4.00(8.50) \right) + \sqrt{3.00^2 + 4.00^2} = 114 \text{ cm}^2$$

33. $V = \frac{1}{3} BH = \frac{1}{3} (250^2) (60) = 3,300,000 \text{ yd}^3$

40. $(\quad) (\quad)$

Area = $\pi \cdot 3 + 0.25 \cdot 4.25 = 41 \text{ in.}^2$

41. $V = \text{cylinder} + \text{cone (top of rivet)}$

$$= \pi r^2 h + \frac{1}{3} \pi r^2 h$$

$$= \pi (0.625 / 2)^2 (2.75) + \frac{1}{3} \pi (1.25 / 2)^2 (0.625)$$

$$= 1.10 \text{ in.}^3$$

42. $p = 18 = 2r + \pi r$

$$= \frac{18}{\pi + 2}$$

$$V = \frac{1}{2} \left(\frac{18}{\pi + 2} \right)^2 (0.075) \cdot \pi$$

$$2 \left| \pi + 2 \right|$$

$$V = 1.4 \text{ m}^2$$

$$\left(\frac{4}{3} \right)$$

43. $V = \frac{4}{3} \pi r^3 = 0.92V = 0.92 \pi r^3$

$$r^2 = 0.97 r_1$$

radius decreased by 3%

44.

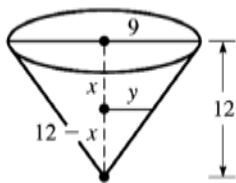

$$\frac{9}{12} = \frac{y}{12 - x}$$

$$y = \frac{3}{4} (12 - x)$$

$$= \frac{1}{2} \pi \cdot \frac{9^2}{2} \cdot 12 \cdot 1$$

$$= -\pi \cdot |-(12 - x)| \cdot (12 - x)$$

Chapter 2 Review Exercises

1. $\angle CGE = 180^\circ - 148^\circ = 32^\circ$

2. $\angle EGF = 180 - 148 - 90 = 58$

3. $\angle DGH = 180^\circ - 148^\circ = 32^\circ$

4. $\angle EGI = 180 - 148 + 90 = 122$

5. $c = 9^2 + 40^2 = 41$

6. $c^2 = a^2 + b^2 = 14^2 + 48^2 \Rightarrow c = 50$

7. $c^2 = a^2 + b^2 = 400^2 + 580^2 \Rightarrow c = 700$

8. $c = a + b \Rightarrow 6500 = a + 5600 \Rightarrow a = 3300$

9. $a = \sqrt{0.736^2 - 0.380^2} = 0.630$

10. $a = \sqrt{128^2 - 25.1^2} = 126$

11. $c^2 = a^2 + b^2 \Rightarrow 36.1^2 = a^2 + 29.3^2 \Rightarrow a = 21.1$

12. $c^2 = a^2 + b^2 \Rightarrow 0.885^2 = 0.782^2 + b^2 \Rightarrow b = 0.414$

13. $P = 3s = 3(8.5) = 25.5 \text{ mm}$

14. $p = 4s = 4(15.2) = 60.8 \text{ in.}$

$$\begin{array}{r} 2 \quad 3 \overline{) 4} \\ x = 12 - \sqrt[3]{64} \\ x = 2.50 \text{ cm} \end{array}$$

$$15. \quad A = \frac{1}{2}bh = \frac{1}{2}(0.125)(0.188) = 0.0118 \text{ ft}^2$$

16.

$$2 \quad 2$$

$$s = \frac{1}{2}(a + b + c) = \frac{1}{2}(175 + 138 + 119) = 216$$

2

2

$$\begin{aligned}A &= \sqrt{s(s-a)(s-b)(s-c)} \\ &= \sqrt{16(216-175)(216-138)(216-119)} \\ A &= 8190 \text{ ft}^2\end{aligned}$$

$$17. C = \pi d = \pi (98.4) = 309 \text{ mm}$$

$$18. p = 2l + 2w = 2(2980) + 2(1860) = 9680 \text{ yd}$$

$$19. A = \frac{1}{2}h(b+b) = \frac{1}{2}(34.2)(67.2+126.7) = 3320 \text{ in.}^2$$

$$20. A = \pi r^2 = \pi \left(\frac{32.8}{2} \right)^2 = 845 \text{ m}^2$$

$$21. V = Bh = \frac{1}{2}(26.0)(34.0)(14.0) = 6190 \text{ cm}^3$$

$$22. V = \pi r^2 h = \pi (36.0)^2 (2.40) = 9770 \text{ in.}^3$$

$$23. V = \frac{1}{3}Bh = \frac{1}{3}(3850)(125) = 160,000 \text{ ft}^3$$

$$24. V = \frac{4}{3}\pi r^3 = \frac{4}{3}\pi \left(\frac{2.21}{2} \right)^3 = 5.65 \text{ mm}^3$$

$$25. A = 6e^2 = 6(0.520)^2 = 1.62 \text{ m}^2$$

$$26. A = 2\pi r^2 + 2\pi rh = 2\pi \left(\left(\frac{12.0}{2} \right)^2 + \left(\frac{12.0}{2} \right)(58.0) \right)$$

$$A = 2410 \text{ ft}^2$$

$$27. s^2 = r^2 + h^2 = 1.82^2 + 11.5^2 \Rightarrow s = \sqrt{1.82^2 + 11.5^2}$$

$$S = \pi rs = \pi (1.82)\sqrt{1.82^2 + 11.5^2}$$

$$S = 66.6 \text{ in.}^2$$

$$28. A = 4\pi r^2 = 4\pi \left(\frac{12,760}{2} \right)^2 = 5.115 \times 10^8 \text{ km}^2$$

$$29. \angle BTA = \frac{50}{2} = 25^\circ$$

$$30. \angle TBA = 90^\circ, \angle BTA = 25^\circ \Rightarrow \angle TAB = 90^\circ - 25^\circ$$

$$34. AD = \sqrt{6^2 + (4+4)^2} = 10$$

$$35. \frac{BE}{4} = \frac{10}{10} \Rightarrow BE = 2.4$$

$$36. \frac{AE}{4} = \frac{8}{10} \Rightarrow AE = 3.2$$

$$37. P = b + \sqrt{b^2 + (2a)^2} + \frac{1}{2}\pi(2a) = b + \sqrt{b^2 + 4a^2} + \pi a$$

$$38. p = \frac{1}{2}(2\pi s) + 4s = \pi s + 4s$$

$$39. A = \frac{1}{2}b(2a) + \frac{1}{2}\pi(a)^2 = ab + \frac{\pi a^2}{2}$$

$$40. A = \frac{1}{2}(\pi s^2) + s^2$$

41. A square is a rectangle with four equal sides and a

rectangle is a parallelogram with perpendicular intersecting sides so a square is a parallelogram.

A rhombus is a parallelogram with four equal sides and since a square is a parallelogram, a square is

a rhombus.

42. If two angles are equal then so is the third and the triangles are similar.

$$43. A = \pi r^2, r \Rightarrow nr \Rightarrow A = \pi (nr)^2 = n^2 (\pi r^2)$$

The area is multiplied by n^2 .

$$44. V = e^3; e \Rightarrow ne \Rightarrow V = (ne)^3 = n^3 e^3$$

3

$$= 65^\circ$$

The volume is multiplied by n .

31. $\angle BTC = 90^\circ - \angle BTA = 90^\circ - 25^\circ = 65^\circ$

32. $\angle ABT = 90^\circ$

(any angle inscribed in a semi-circle is 90°)

33. $\angle ABE = 90^\circ - 37^\circ = 53^\circ$

45.

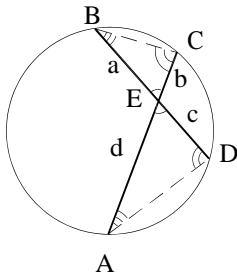

$\angle BEC = \angle AED$, vertical \angle 's.
 $\angle BCA = \angle ADB$, both are inscribed in \overline{AB}
 $\angle CBE = \angle CAD$, both are inscribed in \overline{CD}
 which shows $\triangle AED \sim \triangle BEC \Rightarrow \frac{a}{d} = \frac{b}{c}$

46. $\angle B + 2(90^\circ) + 36^\circ = 180^\circ$

$\angle B = 144^\circ$

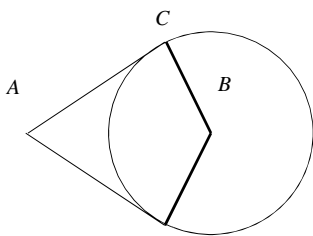

47. $2(\text{base angle}) + 38^\circ = 180^\circ$
 base angle = 71°

48. The two volumes are equal.

$$4\pi \left(\frac{1.50}{2} \right)^3 = \pi \left(\frac{14.0}{2} \right)^2 \cdot t$$

$t = 0.0115 \text{ in.}$

49. $L = \sqrt{0.48^2 + 7.8^2} = 7.8 \text{ m}$

50. $c = \sqrt{2100^2 + 9500^2} = 9700 \text{ ft}$

51.

52. $A = \left(\frac{18.0}{4} \right)^2 + 2\pi \left(\frac{18.0}{8} \right)^2 = 52.1 \text{ cm}^2$

53. $\frac{AB}{13} = \frac{14}{18}$
 $AB = 10 \text{ m}$

54.

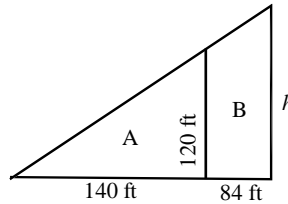

$\frac{h}{140 + 84} = \frac{120}{140} \Rightarrow h = 192$

area of A = $\frac{1}{2}(140)(120) = 8400 \text{ ft}^2$
 area of B = $\frac{1}{2}(120 + 192)(84) = 13,000 \text{ ft}^2$

55. $\frac{FB}{4.5} = \frac{1.60}{1.20} \Rightarrow FB = 6.0 \text{ m}$

56. $\frac{DE}{16} = \frac{33}{24} \Rightarrow DE = 22 \text{ in.}$

57. The longest distance in inches between points on the photograph is,

$\sqrt{8.00^2 + 10.0^2} = 12.8 \text{ in.}$ from which

$\frac{x}{12.8} = \frac{18,450}{1}$

$x = 12.8 \cdot 18,450 \text{ in.} \left(\frac{1 \text{ ft}}{12 \text{ in.}} \right) \left(\frac{\text{mi}}{5280 \text{ ft}} \right)$

$x = 3.73 \text{ mi}$
 58. $MA = \frac{\pi \left(\frac{3.10}{2} \right)^2}{2} = 1.90$
 $\frac{\pi \left(\frac{2.25}{2} \right)^2}{2}$

$$p = 6 \left(\frac{2.4}{\sqrt{2}} \right) = 10 \text{ cm}$$

)

$$59. c = \pi D = \pi (7920 + 2(210)) = 26,200 \text{ mi}$$

$$60. \quad c = 2\pi r = 651 \Rightarrow r = \frac{651}{2\pi}$$

$$A = \pi r^2 = \pi \left(\frac{651}{2\pi} \right)^2 = 33,700 \text{ m}^2$$

$$61. \quad A = (4.0)(8.0) - 2\pi \cdot \frac{1.0}{4} = 30 \text{ ft}^2$$

62.

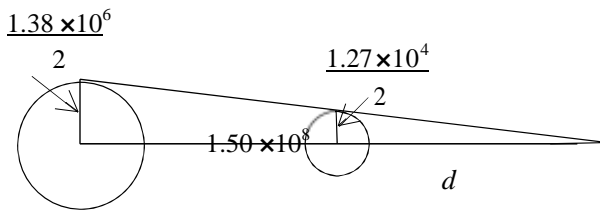

$$\frac{d}{\frac{1.27 \times 10^4}{2}} = \frac{d + 1.50 \times 10^8}{\frac{1.38 \times 10^6}{2}}$$

$$d = 1.39 \times 10^6$$

$$63. \quad A = \frac{250}{3} [220 + 4(530) + 2(480)]$$

$$[4(320 + 190 + 260) + 2(510) + 4(350)]$$

$$[2(730) + 4(560) + 240]$$

$$A = 1,000,000 \text{ m}^2$$

$$64. \quad V = \frac{250}{2} [560 + 2(1780) + 2(4650) + 2(6730) + 2(5600) + 2(6280) + 2(2260) + 230]$$

$$V = 6,920,000 \text{ ft}^3$$

$$65. \quad V = \pi r^2 h = \pi \left(\frac{4.3}{2} \right)^2 (13) = 190 \text{ m}^3$$

$$67. \quad \sqrt{(500+10)^2 - 500^2} = 10 \text{ ft}$$

68.

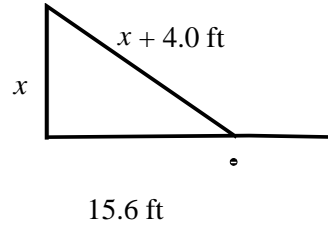

$$(x + 4.0)^2 = x^2 + 15.6^2$$

$$x = 28.4$$

$$x + 4 = 32.4 \text{ ft, length of guy wire}$$

69.

$$1500 \text{ m}$$

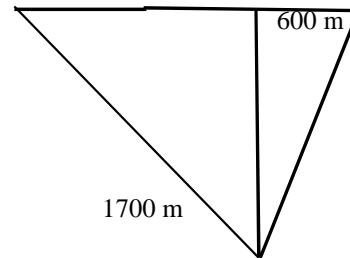

$$d = 1700^2 - 1500^2 + 600^2$$

$$d = 1000 \text{ m}$$

70.

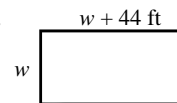

$$p = 2l + 2w$$

$$(\quad)$$

$$288 = 2w + 44 + 2w$$

$$w = 50 \text{ ft}$$

$$l = w + 44 = 94 \text{ ft}$$

66. Area of cross section = area of six equilateral triangles with sides of 2.50 each triangle has
2.50 (3)

$$71. V = \pi r^2 h + \frac{1}{2} \cdot \frac{4}{3} \pi r^3$$

$$\text{semi-perimeter} = \frac{\quad}{2} = 3.75$$

$$= \frac{1}{4} \pi \left(\frac{4.75 + 2.50}{2} \right)^2 - \frac{1}{4} \pi (2.50)^2$$

$$V = \text{area of cross section} \times 6.75$$

$$= 6\sqrt{3.75(3.75 - 2.50)^3} \times 6.75$$

$$= 110 \text{ m}^3$$

$$\left(\frac{2}{2} \right) \left(\frac{1}{2} \right) \left(\frac{2}{2} \right) \left(\frac{3}{2} \right) \left(\frac{1}{2} \right)$$
$$\left(\frac{7.48 \text{ gal}}{\text{ft}^3} \right)$$
$$= 159 \text{ gal}$$

72.

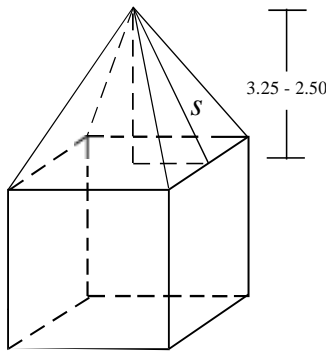

tent surface area

= surface area of pyramid + surface area of cube

$$= \frac{1}{2}ps + 4e^2$$

$$= \frac{1}{2}(4)(2.50)\sqrt{(3.25 - 2.50)^2 + \left(\frac{2.50}{2}\right)^2} + 4(2.50)^2$$

$$= 32.3 \text{ m}^2$$

73. $w = \frac{16}{9} \Rightarrow w = \frac{16h}{9}$

$$152^2 = w^2 + h^2 = \left(\frac{16h}{9}\right)^2 + h^2 \Rightarrow h = 74.5 \text{ cm}$$

$$w = \frac{16h}{9} = 132 \text{ cm}$$

74.

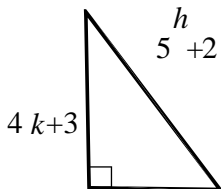

$$3k - 1$$

$$(5k + 2)^2 = (4k + 3)^2 + (3k - 1)^2$$

$$k = 3$$

$$4k + 3 = 15, 3k - 1 = 8$$

$$A = \frac{1}{2}(8)(15) = 60 \text{ ft}^2$$

Note: 1) $3k - 1 > 0 \Rightarrow k > \frac{1}{3}$

75.

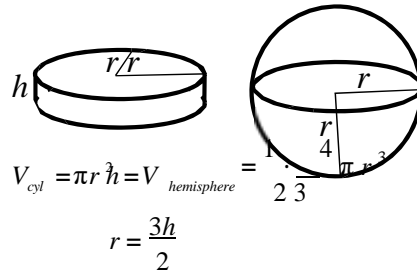

76.

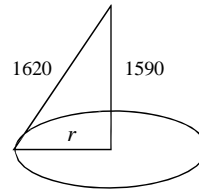

$$A = \pi r^2 \left(\frac{1}{2} \left(\frac{1620^2 + 1590^2}{r^2} \right) \right) = 303,000 \text{ km}^2$$

77. Label the vertices of the pentagon ABCDE. The

area is the sum of the areas of three triangles, one with sides 921, 1490, and 1490 and two with sides 921, 921, and 1490. The semi-perimeters are given by

$$s_1 = \frac{921 + 921 + 1490}{2} = 1666 \text{ and}$$

$$s_2 = \frac{921 + 1490 + 1490}{2} = 1950.5.$$

$$A = 2\sqrt{1666(1666-921)(1666-921)(1666-1490)} + \sqrt{1950.5(1950.5-1490)(1950.5-1490)} + \sqrt{(1950.5-921)^2}$$

3

- 2) There is a solution for $\frac{1}{3} < k < 1$.
- 3) For $k = 1$ the triangle solution is an isosceles, but not right triangle.

$$= 1,460,000 \text{ ft}^2$$

