

Test Bank for Basic Technical Mathematics 10th Edition by Washington ISBN

0133083500 9780133083507

Solution Manual

<https://testbankpack.com/p/solution-manual-for-basic-technical-mathematics-10th-edition-by-washington-isbn-0133083500-9780133083507/>

Test Bank

<https://testbankpack.com/p/test-bank-for-basic-technical-mathematics-10th-edition-by-washington-isbn-0133083500-9780133083507/>

MULTIPLE CHOICE. Choose the one alternative that best completes the statement or answers the question. Solve the problem.

1) Given that $\overline{AB} \parallel \overline{DC}$ & $\overline{AD} \parallel \overline{BC}$, find the measure of angle x.

1) _____

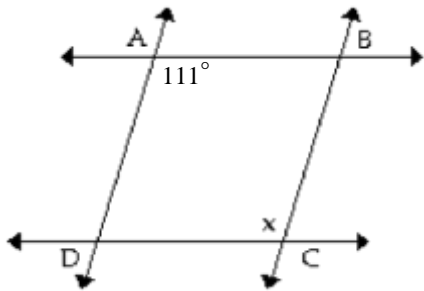

A) -89°

B) 131°

C) 111°

D) 69°

2) If $\overline{AB} \parallel \overline{PR}$, $\angle P = 47^\circ$, and $\angle Q = 48^\circ$, find the measure of angle x.

2) _____

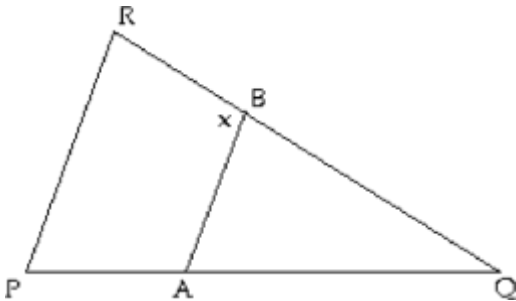

A) 48°
 85°

B) 47°

C) 95°

D)

3) Find the supplement of 3° .

3) _____

A) 267°
 357°

B) 177°

C) 87°

D)

4) Find the supplement of 153° .

4) _____

A) Not possible
 27°

B) 117°

C) 207°

D)

5) Find the complement of 50° .

1

A) 220°



5) _____

6) Find the measure of
angle x . $a = 63^\circ$

A) 22°

B) 27°

C) 37°

D) 17°

6) _____

7) Find the measure of angle x.

7) _____

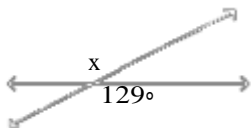

- A) 51° B) 139° C) 39° D) 129°

8) Give the measure of the acute angle: 79° , 90° , 118° , 180° .

8) _____

- A) 118° B) 180° C) 79° D) 90°

9) Give the measure of the obtuse angle: 48° , 90° , 144° , 180° .

9) _____

- A) 144° B) 180° C) 90° D) 48°

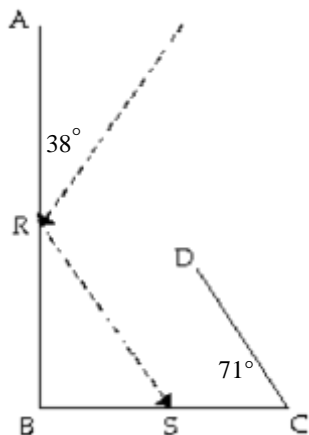

10)

10) _____

When a beam of light is reflected from a smooth surface, the angle formed by the incoming beam with the surface is equal to the angle formed by the reflected beam and the surface. The beam of light in the figure makes an angle of 38° with \overline{RA} . Complete the path of the light beam as it reflects from \overline{AB} , from \overline{BC} , from \overline{DC} , and from \overline{AB} again. At what angle does the beam reflect from \overline{AB} the second time?

- A) 33° B) 95° C) 76° D) 71°

11) If Main Street is parallel to First Street, find the value of x.

11) _____

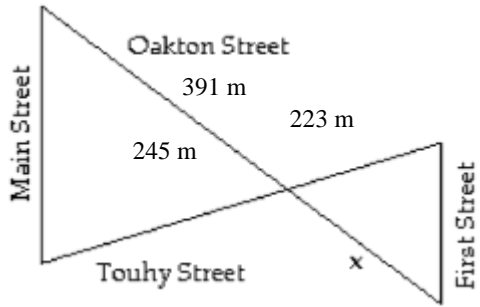

A) 356 m

B) 223 m

C) 140 m

D) 430 m

- 12) An electric circuit board has equally spaced parallel wires with connections at points A, B, and C, as shown in the figure. If $AB = 2.61$ cm, what is the length of BC?

12) _____

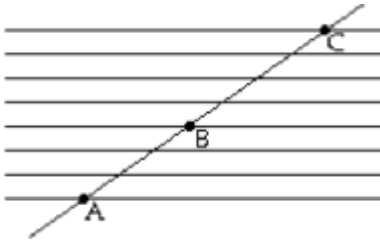

- A) 1.49 cm B) 2.61 cm C) 3.48 cm D) 3.26 cm

- 13) A part used in manufacturing is shown in the figure. If the upper and lower sections are parallel, what is the angle between the diagonal and the upper section?

13) _____

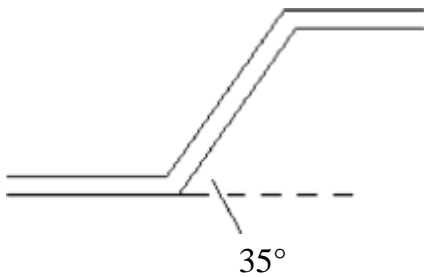

- A) 55° B) 145° C) 125° D) 35°

- 14) A beam of light is partly reflected, and the remainder of the beam passes straight through the surface. Find the angle (angle O) between the surface and the part that passes through.

14) _____

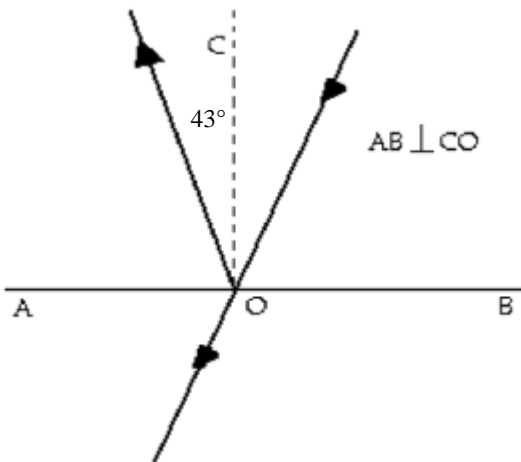

- A) 47° B) 88° C) 133° D) 43°

15) A pool ball is hit as shown in the diagram. Find the value of x .

15) _____

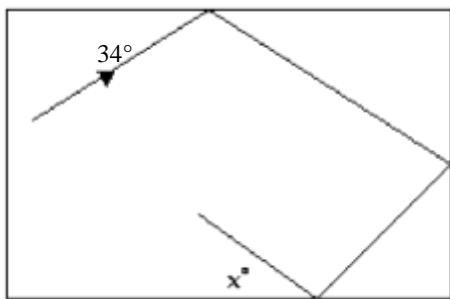

- A) 29° B) 79° C) 56° D) 34°

16) Trusses are often used in the construction of buildings. If $\angle DAB = 49^\circ$ what is the measure of $\angle BDF$ in the truss shown below.

16) _____

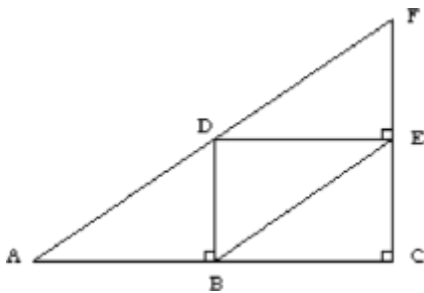

- A) 41° B) 139° C) 90° D) 49°

17) Two angles of a triangle are 40° and 10° . Find the third angle.

17) _____

- A) 50° B) 130° C) 310° D) 40°

18) Two angles of a triangle are 19° and 29° . Find the third angle.

18) _____

- A) 42° B) 132° C) 48° D) 312°

19) One of the base angles of an isosceles triangle is 36° . Find the measures of the other two angles. A) $36^\circ, 72^\circ$ B) $36^\circ, 18^\circ$ C) $36^\circ, 288^\circ$ D) $36^\circ, 108^\circ$

19) _____

20) Find x .

20) _____

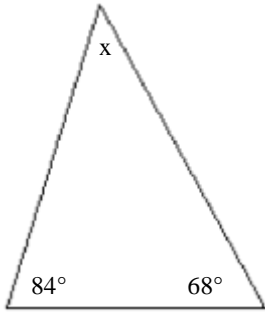

A) 76°

B) 84°

C) 68°

D) 28°

21) Find $\angle A$.

21) _____

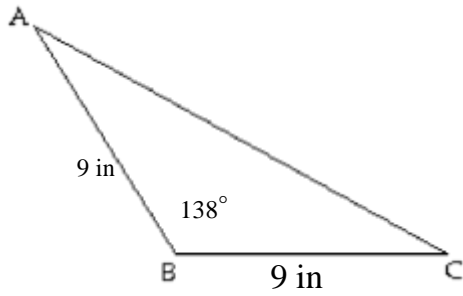

- A) 111° B) 21° C) 16° D) 42°

22) Determine the value of x.

22) _____

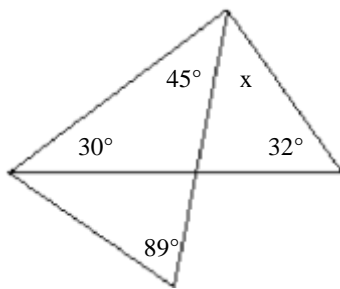

- A) 59° B) 73° C) 118° D) 87°

Find the perimeter.

23)

23) _____

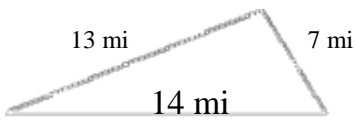

- A) 33 mi B) 34 mi C) 27 mi D) 49 mi

24)

24) _____

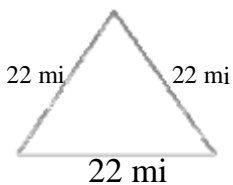

- A) 242 mi B) 65 mi C) 66 mi D) 44 mi

25)

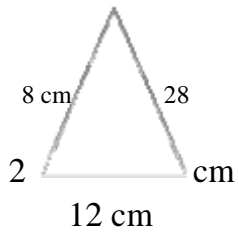

A) 56 cm

B) 68 cm

C) 66 cm

D) 168 cm

25) _____

26)



A) 31 in.

B) 33 in.

C) 32 in.

D) 59.5 in.

26) _____

Find the area.

27)

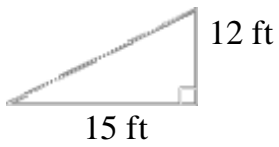

A) 45 ft²

B) 180 ft²

C) 90 ft²

D) 72

27) _____

28)

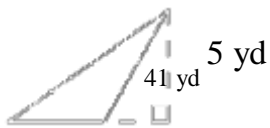

A) 700 yd²

B) 718 yd²

C) 610 yd²

D) 350 yd²

28) _____

29)

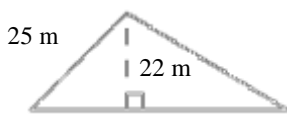

A) 310 m²

B) 240 m²

C) 620 m²

D) 280 m²

29) _____

30)

30) _____

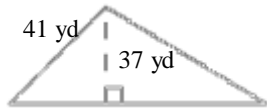

- 44.5 yd
- A) 1600 yd² B) 680 yd² C) 760 yd² D) 820 yd²

31)

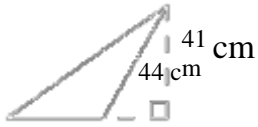

28.5 cm

- A) 840 cm² B) 580 cm² C) 902 cm² D) 1200 cm²

31) _____

32)

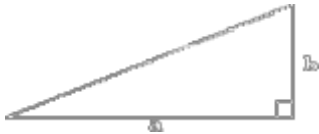

a = 49 in., b = 43 in.

- A) 550 in.² B) 920 in.² C) 2100 in.² D) 1100 in.²

32) _____

33)

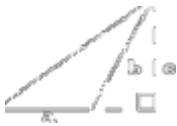

a = 23 m, b = 46 m, c = 41 m

- A) 470 m² B) 943 m² C) 840 m² D) 940 m²

33) _____

34)

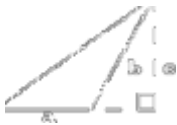

a = 36.5 yd, b = 53 yd, c = 47 yd

- A) 860 yd² B) 1700 yd² C) 1100 yd² D) 1200 yd²

34) _____

Find the missing length in the right triangle.

35)

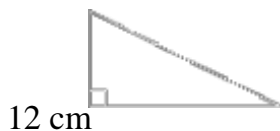

35) _____

15 cm

A) 190 cm

B) 19 cm

C) 370 cm

D) 14 cm

36)

36) _____

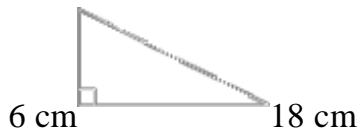

A) 290 cm
cm

B) 17 cm

C) 12 cm

D) 150

37)



- A) 490 in. B) 22 in. C) 250 in. D) 16 in.

37) _____

38)

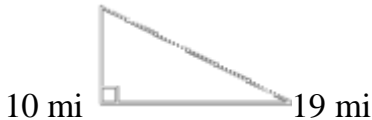

- A) 260 mi B) 16 mi C) 15 mi D) 130 mi

38) _____

39) The legs of a right triangle are 55.2 cm and 33.0 cm. Find the length of the hypotenuse.

- A) 44 cm B) 64.3 cm C) 64 cm D) 44.2 cm

39) _____

40) The hypotenuse of a right triangle is 87.7 in. and one leg is 77.7 in. Find the length of the other leg.

- A) 117 in. B) 40.7 in. C) 41 in. D) 120 in.

40) _____

Solve the problem. Round your result to an appropriate number of significant digits.

41) In order to measure the distance across a pond (from A to B), Yuko made the measurements shown in the drawing. What is the distance?

41) _____

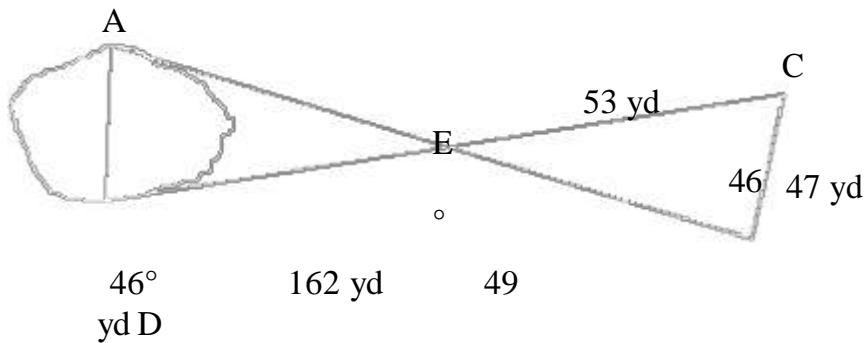

- A) 140 yd B) 170 yd C) 160 yd D) 180 yd

42) A church steeple casts a shadow 101 ft long, and at the same time a 7.00-ft post

cast a shadow 6.00 ft

long. How high is the steeple?

A) 118 ft

B) 102 ft

C) 100 ft

D) 87 ft

42) _____

43) A line from the top of a cliff to the ground passes just over the top of a pole 7.0 ft high and meets the ground at a point 9.0 ft from the base of the pole. If the point is 82 ft from the base of the cliff, how high is the cliff?

43) _____

A) 60 ft

B) 0.80 ft

C) 1.00 ft

D) 64 ft

44) _____

- 44) A lake lies between A and C, and lines AB and DE run north-south. If $AB = 7.8$ mi, $DE = 1.4$ mi, and $DC = 1.2$ mi, how far is it from A to C?

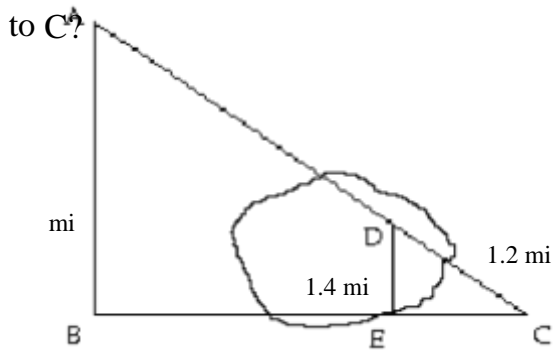

7.8

- A) 9.1 mi B) 6.7 mi C) 5.5 mi D) 7 mi

- 45) Raul, who is 1.53 m tall, wishes to find the height of a tree. He walks 21.11 m from the base of the tree along the shadow of the tree until his head is in a position where the tip of his shadow exactly overlaps the end of the tree top's shadow. He is now 8.73 m from the end of the shadows. How tall is the tree? Round to the nearest hundredth.

45) _____



- A) 0.633 m B) 3.70 m C) 5.23 m D) 2.61 m

- 46) On a cloudy day, John needed to know the height of a window in a building. John positioned a mirror on the ground between himself and the building so that when he looked in the mirror, he saw the window. If the mirror was 23.46 cm from his feet and 34.51 m from the base of the building and John's eye was 2 m above the ground, how high up on the building was the window located? Round to the nearest unit.

46) _____

- A) 2.94 m B) 136 m C) 294 m D) 1.36 m

- 47) Joe has a pennant for the University of Michigan. It is in the shape of an

isosceles triangle. If

each equal side is 79.8 cm and the third side is 31.0 cm, what is the area of the pennant? 47) _____

- A) 1210 cm^2 B) 191 cm^2 C) 1240 cm^2 D) 1140 cm^2

48) A rectangular classroom is 11.0 ft wide, 20.0 ft long, and 8.0 feet high. What is the length of the longest diagonal from one corner to another corner of the room? 48) _____

- A) 24 ft B) 31 ft C) 39 ft D) 23 ft

Solve the problem.

49) Find the perimeter of a square with a side of 2.31 cm. 49) _____

- A) 9.2 cm B) 4.62 cm C) 5.34 cm D) 9.24 cm

- 50) Find the perimeter of a rhombus with a side of 1.83 mm. 50) _____
 A) 7.32 mm B) 7.3 mm C) 3.35 mm D) 3.66 mm
- 51) Find the perimeter of a square with a side of 20.3 in. 51) _____
 A) 81.2 in. B) 412.1 in. C) 81 in. D) 81.20 in.
- 52) Find the perimeter of a rhombus with a side of 19.2 ft. 52) _____
 A) 81 ft B) 76.8 ft C) 368.6 ft D) 38.4 ft
- 53) Find the perimeter of a rectangle with length of 78.24 cm and width of 81.61 cm. 53) _____
 A) 6385 cm B) 319.70 cm C) 6385.2 cm D) 319.7 cm
- 54) Find the perimeter of a rectangle with length of 142.73 in. and width of 200.61 in. 54) _____
 A) 686.68 in. B) 28,633.1 in. C) 686.7 in. D) 28,633 in.
- 55) Find the perimeter of an isosceles trapezoid with short base of 79.0 cm, long base of 91.2 cm, and height of 36.8 cm. 55) _____
 A) 281.6 cm B) 243.8 cm C) 244.3 cm D) 244.8 cm
- 56) Find the perimeter of a parallelogram with bases of 49.7 in. and 41.7 in. and height of 29.1 in. 56) _____
 A) 211.9 in. B) 182.8 in. C) 157.6 in. D) 170.2 in.
- 57) Find the area of a square with side of 4.5 cm. 57) _____
 A) 20 cm² B) 20.3 cm² C) 18.0 cm² D) 10 cm²
- 58) Find the area of a square with side of 30.9 in. 58) _____
 A) 477 in.² B) 955 in.² C) 954.8 in.² D) 123.6 in.²
- 59) Find the area of a rectangle with length 4.1 mm and width 7.1 mm. 59) _____
 A) 29 mm² B) 22.4 mm² C) 29.1 mm² D) 22 mm²

- 60) Find the area of a rectangle with length 27.9 in. and width 31.1 in. 60) _____
A) 867.7 in.² B) 118 in.² C) 118.0 in.² D) 868
in.²
- 61) Find the area of a parallelogram with a base of 63 m and a height of 39 m. 61) _____
A) 4000 m² B) 2500 m² C) 1500 m² D) 2457
m²
- 62) Find the area of a parallelogram with a base of 95 cm and a height of 36 cm 62) _____
A) 1300 cm² B) 9000 cm² C) 3400 cm² D) 3420
cm²
- 63) Find the area of a parallelogram with a base of 97 m and a height of 66 m. 63) _____
A) 6400 m² B) 6402 m² C) 9400 m² D) 4400
m²
- 64) Find the area of a trapezoid with short base of 48 ft, long base of 72 ft, 64) _____
and height of 26 ft. A) 1700 ft² B) 1600 ft² C) 940
ft² D) 3100 ft²

65) Find the area.

65) _____

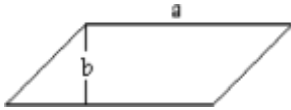

$a = 91 \text{ cm}$ $b = 55 \text{ cm}$

- A) 8300 cm^2 B) 5000 cm^2 C) 3000 cm^2 D) $365,000 \text{ cm}^2$

66) The perimeter of a rectangular room is 54 ft. The width is 12 ft. Find the length.

66) _____

- A) 14 ft B) 15 ft C) 42 ft D) 16 ft

67) A small farm field is a square measuring 350 ft on a side. What is the perimeter of the field? If you double the length of each side of the field, what is the new perimeter?

67) _____

- A) 350 ft, 1400 ft B) 700 ft, 2800 ft
C) 1400 ft, 2800 ft D) 700 ft, 1400 ft

68) A one-story building is 139 ft by 192 ft. If a square patio with sides 29 ft occupies the center of the building, how much area remains for offices?

68) _____

- A) 660 ft^2 B) 630 ft^2 C) 540 ft^2 D) $26,000 \text{ ft}^2$

69) A field is in the shape of a parallelogram with sides of length 121.1 ft and 22.34 ft. The altitude to the longer side is 13.63 ft. Find the length of fencing which must be purchased to enclose the entire field.

69) _____

- A) 269.5 ft B) 1651 ft C) 286.88 ft D) 286.9 ft

70) A bike trail is in the shape of a trapezoid. Find the distance around the trail.

70) _____

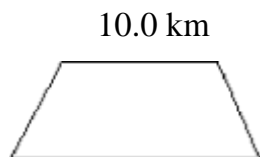

- A) 68.55 km B) 34.80 km C) 34.8 km D) 23.9 km

71) A newly built house has a room in it such that the length is 2.6 ft more than the width. The perimeter is 48 ft. What are the dimensions?

A) 23 ft by 25 ft

C) 24 ft by 26.6 ft

D) 10.7 ft by 13.3 ft

71) _____

72) A home has a living room that is 12 ft wide and 17 ft long. The height is 9 ft. Bob needs to paint the room. He has to paint the walls and the ceiling. (He will not paint the floor.) There are two 3.0 ft by 5.0 ft windows and a 4.0 ft by 7.0 ft opening into the room that will not be painted. A gallon of paint covers 320 ft². How many gallons of paint are needed? (All data are accurate to two significant figures.)

72) _____

A) 1.3 gallons

B) 2.3 gallons

C) 2.7 gallons

D) 2.1 gallons

Find the circumference of the circle with the given radius or diameter.

73) $r = 7.33$ cm

73) _____

A) 169 cm

B) 23.0 cm

C) 46.1 cm

D) 46.06 cm

cm

- 74) $r = 0.573$ in. 74) _____
 A) 1.80 in. B) 3.600 in. C) 3.60 in. D) 1.03 in.
- 75) $r = 8.0$ in. 75) _____
 A) 25.1 in. B) 50.27 in. C) 50 in. D) 201.1 in.
- 76) $r = 61.1$ cm 76) _____
 A) 384 cm B) 192 cm C) 383.9 cm D) 11,730 cm
- 77) $d = 9.28$ cm 77) _____
 A) 29.15 cm B) 29.2 cm C) 58.3 cm D) 58.31 cm
- 78) $d = 3.7$ in. 78) _____
 A) 23.2 in. B) 11.6 in. C) 23 in. D) 12 in.
- 79) $d = 85.2$ mm 79) _____
 A) 267.7 mm B) 535 mm C) 268 mm D) 535.3 mm
- 80) $d = 13.0$ ft 80) _____
 A) 81.68 ft B) 40.8 ft C) 81.7 ft D) 40.84 ft

Find the area of the circle.

- 81) A circle with diameter 14 yd 81) _____
 A) 150 yd² B) 620 yd² C) 88 yd² D) 44 yd²
- 82) A circle with diameter 15.7 cm 82) _____
 A) 774 cm² B) 194 cm² C) 49.3 cm² D) 98.6 cm²
- 83) A circle with radius 1.6 in. 83) _____
 A) 10 in.² B) 20 in.² C) 32 in.² D) 8.0 in.²
- 84) A circle with radius 4.74 in. 84) _____
 A) 70.6 in.² B) 282 in.² C) 29.8 in.² D) 59.6 in.²

Determine the indicated arc or angle.

- 85) Find \widehat{BC} . 85) _____

66°

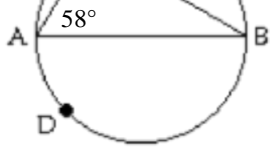

A) 58°

B) 114°

C) 116°

D) 29°

86) Find $\angle ADB$.



86) _____

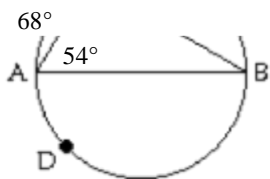

A) 238°

B) 265°

C) 184°

D) 180°

87) Find $\angle ABC$.

87) _____

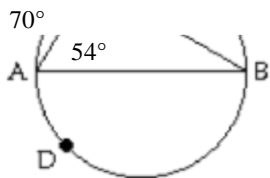

A) 35°

B) 70°

C) 54°

D) 36°

88) Find $\angle ACB$.

88) _____

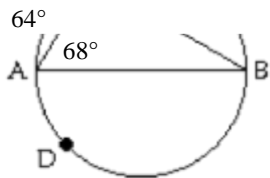

A) 90°

B) 80°

C) 48°

D) 82°

89) Find $\angle AC$.

89) _____

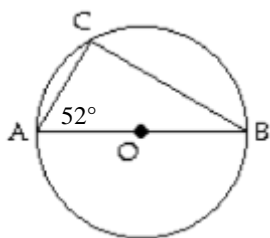

- A) 104°
- C) 76°

- B) Not enough information.
- D) 128°

90) Find $\angle ACB$.

90) _____

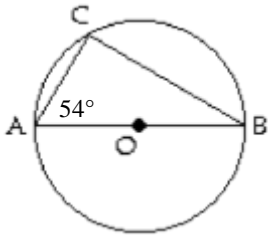

- A) Not enough information.
- C) 126°

- B) 90°
- D) 72°

91) Find $\angle CAB$.

91) _____

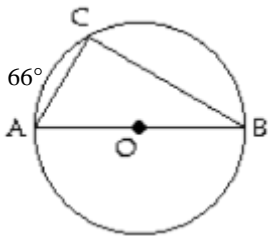

- A) 24°
- C) 57°

- B) Not enough information.
- D) 33°

92) Find $\angle C$.

92) _____

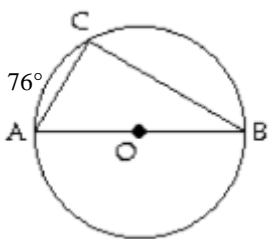

- A) 104°
- C) 76°

- B) 128°
- D) Not enough information.

93) Find $\angle ACB$.

93) _____

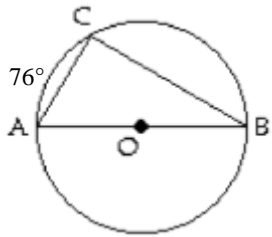

A) Not enough information.
C) 166°

B) 180°
D) 208°

94) Find $\angle ACB$.

94) _____

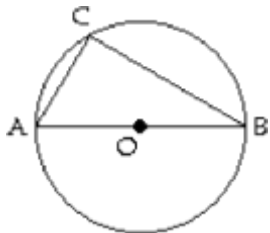

A) Not enough information.
90°

B)

Convert to radian measure. Round to two decimal places.

95) 89.1°

95) _____

A) 1.57
1.56

B) 1.54

C) 1.55

D)

96) 163.9°

96) _____

A) 2.86
2.87

B) 2.75

C) 2.76

D)

97) 59.3°

97) _____

A) 1.03
1.04

B) 1.01

C) 1.02

D)

Solve the problem.

98) A small circular pool is enclosed in a square. Find the area inside the square but outside the circle.

98) _____

2.8 m

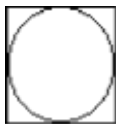

A) 9.5 m²

B) 25 m²

C) 6.2 m²

D) 1.7 m²

99) Find the shaded area in the figure.

99) _____

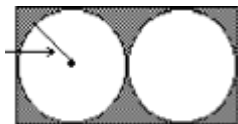

4.61 cm

A) 103 cm²

B) 36.5 cm²

C) 18.2 cm²

D) Not enough information.

100) Semicircles are placed on the sides of an equilateral triangle with sides 3.7 ft as shown. Find the shaded area.

100) ____

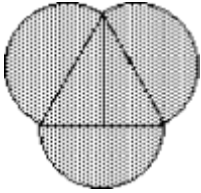

A) 22.1 ft^2

B) 19.6 ft^2

C) 11.3 ft^2

D) 38.2 ft^2

101) A bicycle tire has a radius of 11.0 in. How far will it travel in 115 revolutions?

101) ____

A) 43,700 in.
in.

B) 3970 in.

C) 7950 in.

D) 87,400

- 102) Two wheels of radius 15.34 cm and 13.78 cm respectively rest on the ground. If the centers of the wheels are 37.17 cm apart, how far apart are the points where they touch the ground? 102) ____

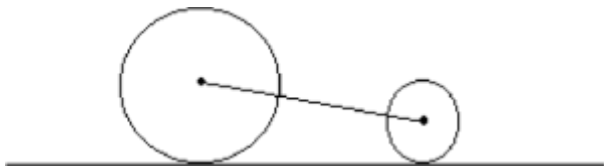

- A) 33.86 cm B) 37.17 cm C) 34.52 cm D) 37.14 cm

- 103) The circumference of a tree is found to be 106 in. What is its radius? 103) ____
 A) 33.7 in. B) 18.3 in. C) 16.9 in. D) 19.0 in.

- 104) What is the area of the largest circle that can be cut from a rectangular plate that is 22.7 cm by 21.4 cm? 104) ____
 A) 360 cm² B) 1530 cm² C) 405 cm² D) 1440 cm²

- 105) Find the length of the pulley belt shown in the figure if the belt crosses at 60° angles. The radius of each circle is 6.74 in. 105) ____

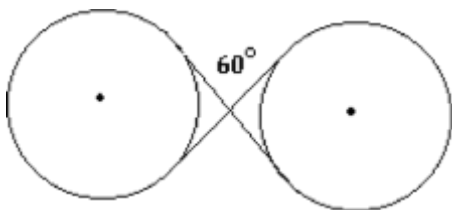

- A) 74.9 in. B) 103 in.
 C) 58.7 in. D) Not enough information.

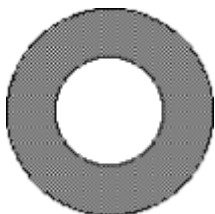

- 106) A washer has an inner radius of 0.23 in. and an outer radius of 0.55 in. Find the area of the washer. 106) ____
 A) 1.1 in.² B) 0.78 in.² C) 0.025 in.² D) 0.95 in.²

Use the trapezoidal rule to find the area.

aerial photograph a region the widths of an area were measured at 0.70-mi intervals as shown in the following table. Find the area.

107) _____

Distance (mi)	0.0	0.7	1.4	2.1	2.8	3.5	4.2	4.9	5.6
Width (mi)	2.2	2.8	3.3	4.2	2.6	1.5	1.5	1.3	4.9

- A) 15 mi^2 B) 13 mi^2 C) 17 mi^2 D) 19 mi^2

108) The widths of a small pond were measured at 1.5-m intervals as shown in the following table. Find the area.

108) _____

Distance (m)	0.0	1.5	3.0	4.5	6.0	7.5	9.0	10.5	12.0
Width (m)	0.0	5.4	8.4	9.2	7.1	6.8	8.6	7.4	0.0

- A) 160 m^2 B) 77 m^2 C) 82 m^2 D) 79 m^2

109) A meadow was measured at 5.70-yd intervals as shown in the following table. Find the area. 109) _____

Distance (yd)	0.0	5.7	11.4	17.1	22.8	28.5	34.2	39.9	45.6
Width (yd)	15.5	11.1	11.8	14.3	10.3	15.5	14.4	11.8	12.1

- A) 592 yd² B) 530 yd² C) 666 yd² D) 587 yd²

110) A parking lot was measured every 100 m (three significant digits). The measurements (in meters) are given in the diagram. Find the area. 110) _____

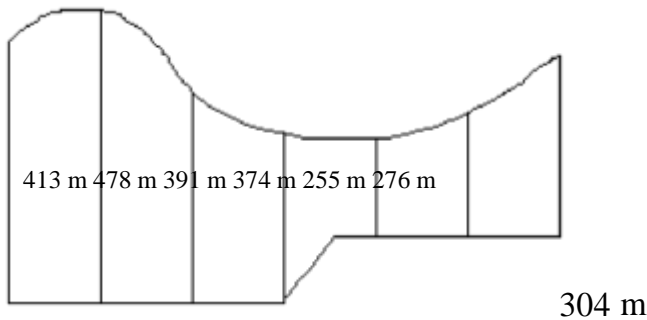

- A) 652,000 m² B) 249,000 m² C) 556,000 m² D) 213,000 m²

111) A pool was measured every 1.75 yd. The distances across the pool (in yards) are given in the diagram. Find the area. 111) _____

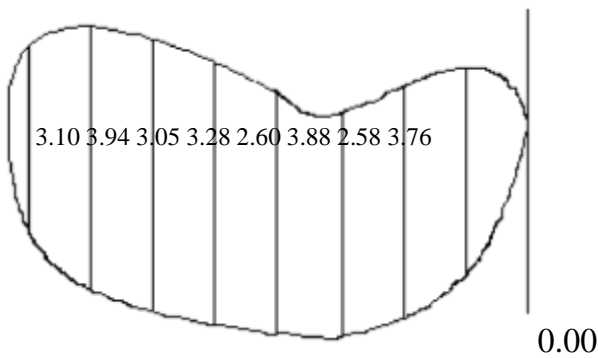

- A) 39.8 yd² B) 57.5 yd² C) 69.1 yd² D) 43.1 yd²

112) A pond was measured every 230 m. The distances across the pond (in meters) are given in the diagram. Find the area. 112) _____

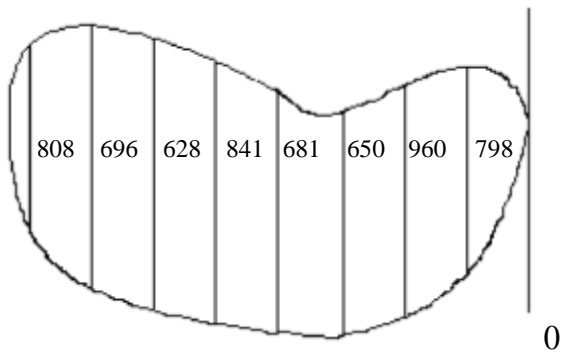

- A) 1,300,000 m² B) 2,000,000 m² C) 1,200,000 m² D) 1,800,000 m²

Use Simpson's Rule to find the area.

- 113) On an aerial photograph a region the widths of an area were measured at 0.40-mi intervals as shown in the following table. Find the area. 113) ____

Distance (mi)	0.0	0.4	0.8	1.2	1.6	2.0	2.4	2.8	3.2
Width (mi)	1.6	4.2	3.5	1.1	3.8	2.2	1.1	3.8	3.3

- A) 11 mi^2 B) 8.9 mi^2 C) 9.8 mi^2 D) 13 mi^2 114) ____
- 114) The widths of a small pond were measured at 1.5-m intervals as shown in the following table. Find the area.

Distance (m)	0.0	1.5	3.0	4.5	6.0	7.5	9.0	10.5	12.0
Width (m)	0.0	1.7	1.7	4.6	4.7	1.8	4.0	2.7	0.0

- A) 64 m^2 B) 32 m^2 C) 42 m^2 D) 37 m^2
- 115) A meadow was measured at 5.60-yr intervals as shown in the following table. Find the area. 115) ____

Distance (yd)	0.0	5.6	11.2	16.8	22.4	28.0	33.6	39.2	44.8
Width (yd)	15.9	13.2	16.1	16.1	15.2	12.5	10.6	10.9	12.1

- A) 562 yd^2 B) 687 yd^2 C) 608 yd^2 D) 602 yd^2
- 116) A parking lot was measured every 100 m (three significant digits). The measurements (in meters) are given in the diagram. Find the area. 116) ____

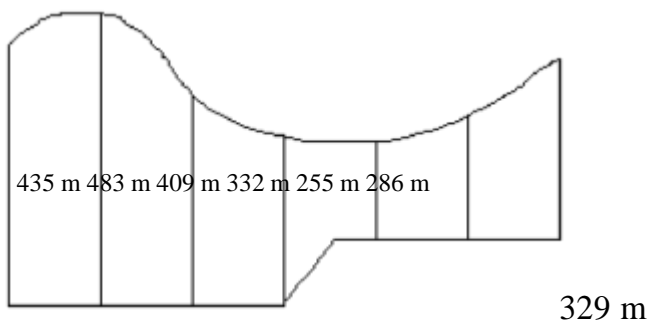

- A) $217,000 \text{ m}^2$ B) $253,000 \text{ m}^2$ C) $187,000 \text{ m}^2$ D) $325,000 \text{ m}^2$
- 117) A pool was measured every 2.00 yd. The distances across the pool (in yards) are given in the diagram. Find the area. 117) ____

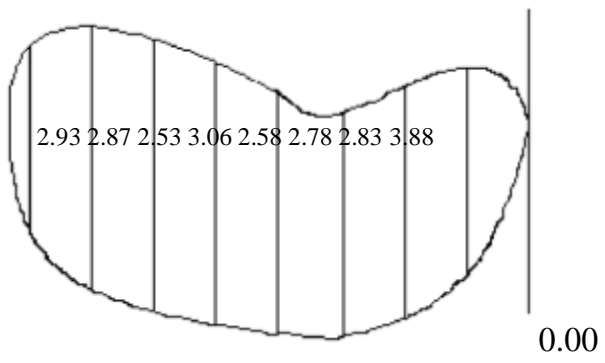

A) 44.0 yd²

B) 39.9 yd²

C) 40.1 yd²

D) 46.1 yd²

118) A pond was measured every 230 m. The distances across the pond (in meters) are given in the diagram. Find the area.

118) ____

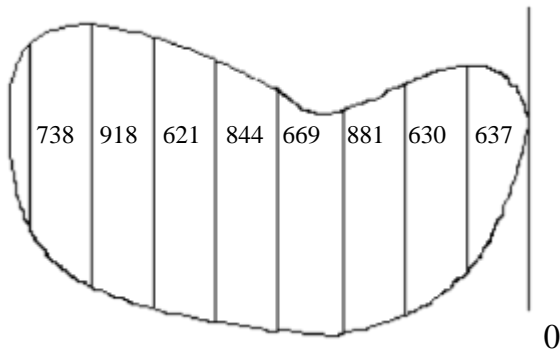

- A) 1,300,000 m² B) 1,400,000 m² C) 1,100,000 m² D) 1,200,000 m²

Find the volume.

119) A cube measuring 28 ft on each edge

119) ____

- A) 780 ft³ B) 84 ft³ C) 1600 ft³ D) 22,000 ft³

120) A box 6.4 ft x 8.4 ft x 6.0 ft

120) ____

- A) 300 ft³ B) 320 ft³ C) 250 ft³ D) 450 ft³

121)

121) ____

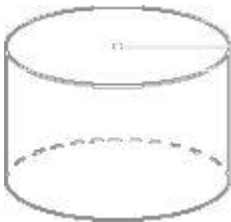

Radius = 6.5 cm, height = 16 cm

- A) 8500 cm³ B) 2100 cm³ C) 330 cm³ D) 650 cm³

122) A sphere with diameter 3.9 yd

122) ____

- A) 16 yd³ B) 31 yd³ C) 17 yd³ D) 250 yd³

123) A cone with height 9 in. and radius 7 in.

123) ____

- A) 100 in.³ B) 900 in.³ C) 700 in.³ D) 500 in.³

124) A cone with height 7 in. and radius 9 in. 124) ____
A) 600 in.^3 B) 900 in.^3 C) 100 in.^3 D) 1000
 in.^3

125) A cone with height 4.5 cm and diameter 4.4 cm 125) ____
A) 23 cm^3 B) 41 cm^3 C) 140 cm^3 D) 91
 cm^3

126) A triangular pyramid with base area 23.9 ft^2 and height 8.0 ft 126) ____
A) 64 ft^3 B) 96 ft^3 C) 62 ft^3 D) 190
 ft^3

- 127) A rectangular pyramid with base area 20.2 m^2 and height 9.0 m 127) ____
A) 61 m^3 B) 59 m^3 C) 180 m^3 D) 91 m^3

Solve the problem.

- 128) Find the total surface area of a box 20.8 cm by 10.5 cm by 24.5 cm . 128) ____
A) 985 cm^2 B) 1970 cm^2 C) 1710 cm^2 D) 1390 cm^2
- 129) Find the total surface area of a cube with an edge of 14 ft . 129) ____
A) 84 ft^2 B) 600 ft^2 C) 340 ft^2 D) 1200 ft^2
- 130) Find the total surface area of a right circular cylinder with $r = 7.4 \text{ in.}$, $h = 6.1 \text{ in.}$ 130) ____
A) 620 in.^2 B) 1000 in.^2 C) 490 in.^2 D) 310 in.^2
- 131) Find the total surface area of a right circular cylinder with $d = 12 \text{ m}$, $h = 7.8 \text{ m}$. 131) ____
A) 880 m^2 B) 370 m^2 C) 260.0 m^2 D) 170 m^2
- 132) Find the total surface area of a right circular cone with diameter 10.1 ft and height 14.5 ft . 132) ____
A) 540 ft^2 B) 1440 ft^2 C) 1240 ft^2 D) 324 ft^2
- 133) Find the total surface area of a regular square pyramid with base edges 6.53 cm and lateral edges 9.93 cm . 133) ____
A) 165 cm^2 B) 122 cm^2 C) 172 cm^2 D) 179 cm^2
- 134) Find the lateral surface area of a right circular cone with a radius of 53.9 cm and a slant height of 91.9 cm . 134) ____
A) $24,700 \text{ cm}^2$ B) $280,000 \text{ cm}^2$ C) $15,600 \text{ cm}^2$ D) 7780 cm^2
- 135) Find the lateral surface area of a regular pyramid with a perimeter of 3.94 ft and a slant height of 2.47 ft . A) 8.81 ft^2

135) ____

136) A cylindrical paint can is 6 inches across the top and about 12 inches high. How many cubic inches of paint could it hold?

- A) 700 in.³ B) 500 in.³ C) 300 in.³ D) 1000 in.³

136) ____

137) The foundation for a cylindrical water tank is a cylinder 24 in in diameter and 5.0 in high. How many cubic in of concrete are needed to build the foundation?

- A) 9000 in³ B) 2300 in³ C) 4500 in³ D) 750 in³

137) ____

138) A certain marine engine has cylinders that are 3.96 cm in diameter and 4.12 cm deep. Find the total volume of 8 cylinders.

- A) 406 cm³ B) 50.7 cm³ C) 820 cm³ D) 812 cm³

138) ____

139) A shipping container has dimensions of 5.4 ft x 3.7 ft x 4.5 ft. What is its volume?

- A) 90 ft³ B) 75 ft³ C) 74 ft³ D) 130 ft³

139) ____

- 140) A model of a pyramid has a square base 520 cm on a side and a height of 210 cm. Find the volume. A) 57,000,000 cm³ B) 15,000,000 cm³ C) 18,900,000 cm³ D) 19,000,000 cm³ 140) ____
- 141) A dog toy is constructed in the shape of a cylinder with a length of 6.9 in. The cylinder has a hemisphere at each end. The diameter is 2.1 in. Find the total volume. A) 130 in.³ B) 24 in.³ C) 26 in.³ D) 29 in.³ 141) ____

Answer Key

Testname: UNTITLED2

- 1) C
- 2) C
- 3) B
- 4) D
- 5) C
- 6) B
- 7) D
- 8) C
- 9) A
- 10) C
- 11) A
- 12) C
- 13) B
- 14) C
- 15) D
- 16) B
- 17) B
- 18) B
- 19) D
- 20) D
- 21) B
- 22) B
- 23) B
- 24) C
- 25) B
- 26) C
- 27) C
- 28) D
- 29) A
- 30) D
- 31) B
- 32) D
- 33) A
- 34) A
- 35) B
- 36) B
- 37) B
- 38) B
- 39) B
- 40) B
- 41) A

- 42) A
- 43) D
- 44) B
- 45) C
- 46) C
- 47) A
- 48) A
- 49) D
- 50) A

Answer Key

Testname: UNTITLED2

- 51) A
- 52) B
- 53) B
- 54) A
- 55) D
- 56) B
- 57) A
- 58) B
- 59) A
- 60) D
- 61) B
- 62) C
- 63) A
- 64) B
- 65) B
- 66) B
- 67) C
- 68) D
- 69) D
- 70) C
- 71) D
- 72) D
- 73) C
- 74) C
- 75) C
- 76) A
- 77) B
- 78) D
- 79) C
- 80) B
- 81) A
- 82) B
- 83) D
- 84) A
- 85) C
- 86) C
- 87) A
- 88) B
- 89) C
- 90) B
- 91) C

- 92) A
- 93) B
- 94) B
- 95) D
- 96) A
- 97) A
- 98) D
- 99) B
- 100) A

Answer Key

Testname: UNTITLED2

- 101) C
- 102) D
- 103) C
- 104) A
- 105) B
- 106) B
- 107) A
- 108) D
- 109) D
- 110) D
- 111) D
- 112) A
- 113) B
- 114) B
- 115) D
- 116) A
- 117) D
- 118) B
- 119) D
- 120) B
- 121) B
- 122) B
- 123) D
- 124) A
- 125) A
- 126) A
- 127) A
- 128) B
- 129) D
- 130) A
- 131) D
- 132) D
- 133) A
- 134) C
- 135) B
- 136) C
- 137) B
- 138) A
- 139) A
- 140) D
- 141) D

