

**Test Bank for Calculus 2nd Edition by Briggs Cochran Gillett ISBN
0321954890 9780321954893**

Full link download

Solution manual: <https://testbankpack.com/p/solutions-manual-for-calculus-2nd-edition-by-briggs-cochran-gillett-isbn-0321954890-9780321954893/>

Test Bank:

<https://testbankpack.com/p/test-bank-for-calculus-2nd-edition-by-briggs-cochran-gillett-isbn-0321954890-9780321954893/>

MULTIPLE CHOICE. Choose the one alternative that best completes the statement or answers the question.
Find the average velocity of the function over the given interval.

1) $y = x^2 + 2x$, [4, 8] 1) _____
 A) 10 B) 14 C) 7 D) 20

2) $y = 7x^3 + 8x^2 - 1$, [-8, -4] 2) _____
 A) 688 B) - 688 C) $\frac{321}{4}$ D) $-\frac{321}{4}$

3) $y = \sqrt{2x}$, [2, 8] 3) _____
 A) $\frac{1}{3}$ B) 2 C) -10^3 D) 7

4) $y = \frac{-3}{x-2}$, [4, 7] 4) _____
 A) 3 B) 7 C) -10^3 D) 2

5) $y = 4x^2$, $\left[0, \frac{7}{4}\right]$ 5) _____
 A) 2 B) 7 C) $\frac{1}{3}$ D) $-10^{\frac{3}{2}}$

6) $y = -3x^2 - x$, [5, 6] 6) _____
 A) -2 B) -34 C) $-\frac{1}{6}$ D) $\frac{1}{2}$

7) $h(t) = \sin(3t)$, $\left[0, \frac{\pi}{6}\right]$ 7) _____
 A) $\frac{6}{\pi}$ B) $\frac{3}{\pi}$ C) 6 D) $-\pi^6$

8) $g(t) = 3 + \tan t$, $\left[\frac{\pi}{4}, \frac{\pi}{4}\right]$ 8) _____
 A) $-\frac{8}{5}$ B) $\frac{4}{\pi}$ C) $-\frac{4}{\pi}$ D) 0

Use the table to find the instantaneous velocity of y at the specified value of x.

9) $x = 1$.

9) _____

x	y
0	0
0.2	0.02
0.4	0.08
0.6	0.18
0.8	0.32
1.0	0.5
1.2	0.72
1.4	0.98

A) 2

B) 0.5

C) 1.5

D) 1

10) $x = 1$.

10) _____

x	y
0	0
0.2	0.01
0.4	0.04
0.6	0.09
0.8	0.16
1.0	0.25
1.2	0.36
1.4	0.49

A) 1

B) 1.5

C) 2

D) 0.5

11) $x = 1$.

11) _____

x	y
0	0
0.2	0.12
0.4	0.48
0.6	1.08
0.8	1.92
1.0	3
1.2	4.32
1.4	5.88

A) 6

B) 8

C) 4

D) 2

12) $x = 2$.

12) _____

x	y
0	10
0.5	38
1.0	58
1.5	70
2.0	74
2.5	70
3.0	58
3.5	38
4.0	10

- A) 4 B) 0 C) 8 D) -8

13) $x = 1$.

13) _____

x	y
0.900	-0.05263
0.990	-0.00503
0.999	-0.0005
1.000	0.0000
1.001	0.0005
1.010	0.00498
1.100	0.04762

- A) 0.5 B) -0.5 C) 1 D) 0

For the given position function, make a table of average velocities and make a conjecture about the instantaneous velocity at the indicated time.

14) $s(t) = t^2 + 8t - 2$ at $t = 2$

14) _____

t	1.9	1.99	1.999	2.001	2.01	2.1
s(t)						

A)

t	1.9	1.99	1.999	2.001	2.01	2.1
s(t)	16.810	17.880	17.988	18.012	18.120	19.210

; instantaneous velocity is 18.0

B)

t	1.9	1.99	1.999	2.001	2.01	2.1
s(t)	16.692	17.592	17.689	17.710	17.808	18.789

; instantaneous velocity is 17.70

C)

t	1.9	1.99	1.999	2.001	2.01	2.1
s(t)	5.043	5.364	5.396	5.404	5.436	5.763

; instantaneous velocity is ∞

D)

t	1.9	1.99	1.999	2.001	2.01	2.1
s(t)	5.043	5.364	5.396	5.404	5.436	5.763

; instantaneous velocity is 5.40

15) $s(t) = t^2 - 5$ at $t = 0$

15) _____

t	-0.1	-0.01	-0.001	0.001	0.01	0.1
s(t)						

A)

t	-0.1	-0.01	-0.001	0.001	0.01	0.1
s(t)	-1.4970	-1.4999	-1.5000	-1.5000	-1.4999	-1.4970

-15.0 ; instantaneous velocity is

B)

t	-0.1	-0.01	-0.001	0.001	0.01	0.1
s(t)	-4.9900	-4.9999	-5.0000	-5.0000	-4.9999	-4.9900

-5.0 ; instantaneous velocity is

C)

t	-0.1	-0.01	-0.001	0.001	0.01	0.1
s(t)	-1.4970	-1.4999	-1.5000	-1.5000	-1.4999	-1.4970

; instantaneous velocity is ∞

D)

t	-0.1	-0.01	-0.001	0.001	0.01	0.1
s(t)	-2.9910	-2.9999	-3.0000	-3.0000	-2.9999	-2.9910

-3.0 ; instantaneous velocity is

Find the slope of the curve for the given value of x.

16) $y = x^2 + 5x$, $x = 4$

16) _____

A) slope is 13

B) slope is $\frac{1}{20}$

C) slope is $-\frac{4}{25}$

D) slope is -39

17) $y = x^2 + 11x - 15$, $x = 1$

17) _____

A) slope is $\frac{1}{20}$

B) slope is -39

C) slope is $-\frac{4}{25}$

D) slope is 13

18) $y = x^3 - 7x$, $x = 1$

18) _____

A) slope is -3

B) slope is -4

C) slope is 3

D) slope is 1

19) $y = x^3 - 2x^2 + 4$, $x = 3$

19) _____

A) slope is 1

B) slope is 0

C) slope is -15

D) slope is 15

20) $y = -4 - x^3$, $x = 1$

20) _____

A) slope is 0

B) slope is -1

C) slope is -3

D) slope is 3

Solve the problem.

21) Given $\lim_{x \rightarrow 0^-} f(x) = Ll$, $\lim_{x \rightarrow 0^+} f(x) = Lr$, and $Ll \neq Lr$, which of the following statements is true? $x \rightarrow 0^+$

21) _____

- I. $\lim_{x \rightarrow 0} f(x) = Ll$
- II. $\lim_{x \rightarrow 0} f(x) = Lr$

III. $\lim_{x \rightarrow 0} f(x)$ does not exist.

A) none

B) II

C) III

D) I

- 22) Given $\lim_{x \rightarrow 0^-} f(x) = L_l$, $\lim_{x \rightarrow 0^+} f(x) = L_r$, and $L_l = L_r$, which of the following statements is false? 22) _____
- I. $\lim_{x \rightarrow 0} f(x) = L_l$
 - II. $\lim_{x \rightarrow 0} f(x) = L_r$
 - III. $\lim_{x \rightarrow 0} f(x)$ does not exist.

A) I B) II C) III D) none

- 23) If $\lim_{x \rightarrow 0} f(x) = L$, which of the following expressions are true? 23) _____

- I. $\lim_{x \rightarrow 0^-} f(x)$ does not exist.
- II. $\lim_{x \rightarrow 0^+} f(x)$ does not exist.
- III. $\lim_{x \rightarrow 0^-} f(x) = L$
- IV. $\lim_{x \rightarrow 0^+} f(x) = L$

A) I and II only B) III and IV only C) II and III only D) I and IV only

- 24) What conditions, when present, are sufficient to conclude that a function $f(x)$ has a limit as x approaches some value of a ? 24) _____

- A) $f(a)$ exists, the limit of $f(x)$ as $x \rightarrow a$ from the left exists, and the limit of $f(x)$ as $x \rightarrow a$ from the right exists.
- B) The limit of $f(x)$ as $x \rightarrow a$ from the left exists, the limit of $f(x)$ as $x \rightarrow a$ from the right exists, and at least one of these limits is the same as $f(a)$.
- C) The limit of $f(x)$ as $x \rightarrow a$ from the left exists, the limit of $f(x)$ as $x \rightarrow a$ from the right exists, and these two limits are the same.
- D) Either the limit of $f(x)$ as $x \rightarrow a$ from the left exists or the limit of $f(x)$ as $x \rightarrow a$ from the right exists

Use the graph to evaluate the limit.

25) $\lim_{x \rightarrow -1} f(x)$

25) _____

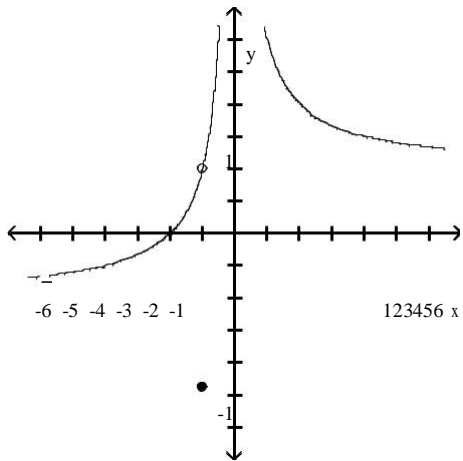

A) -1

B) $-\frac{1}{2}$

C) $\frac{1}{2}$

D) ∞

26) $\lim_{x \rightarrow 0} f(x)$

26) _____

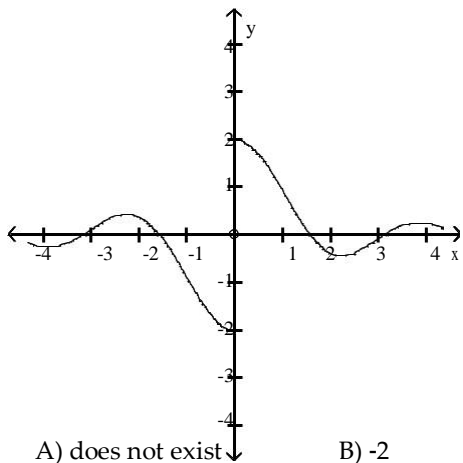

A) does not exist

B) -2

C) 0

D) 2

27) $\lim_{x \rightarrow 0} f(x)$

27) _____

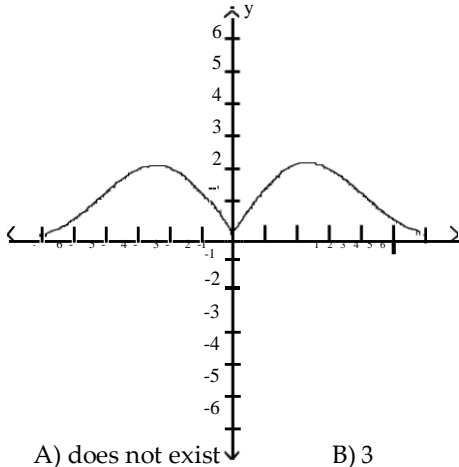

A) does not exist

B) 3

C) 0

D) -3

28) $\lim_{x \rightarrow 0} f(x)$

28) _____

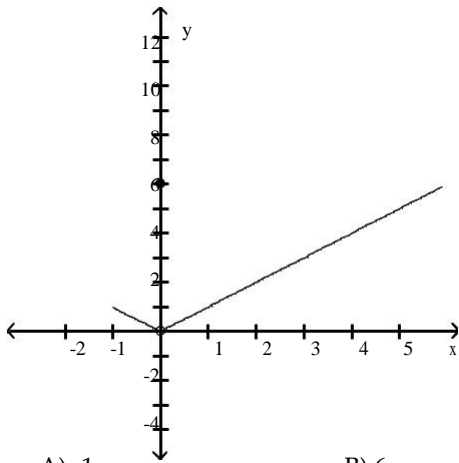

A) -1

B) 6

C) does not exist

D) 0

29) $\lim_{x \rightarrow 0} f(x)$

29) _____

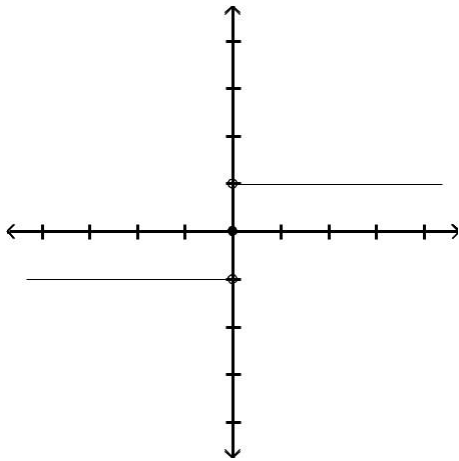

- A) 1 B) does not exist C) ∞ D) -1

30) $\lim_{x \rightarrow 0} f(x)$

30) _____

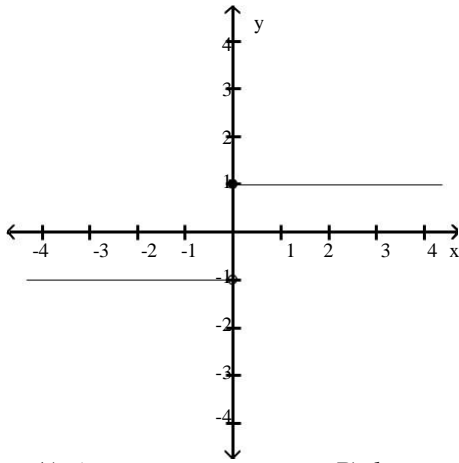

- A) -1 B) does not exist C) 1 D) ∞

31) $\lim_{x \rightarrow 0} f(x)$

31) _____

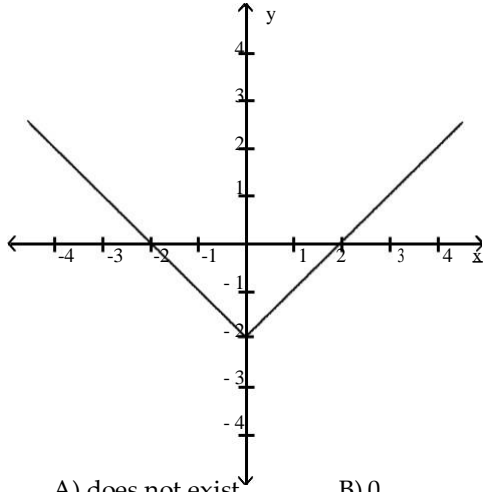

A) does not exist

B) 0

C) 2

D) -2

32) $\lim_{x \rightarrow 0} f(x)$

32) _____

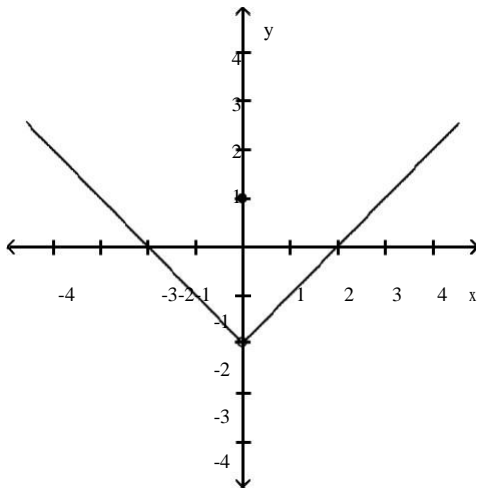

A) -2

B) does not exist

C) 1

D) 0

33) $\lim_{x \rightarrow 0} f(x)$

33) _____

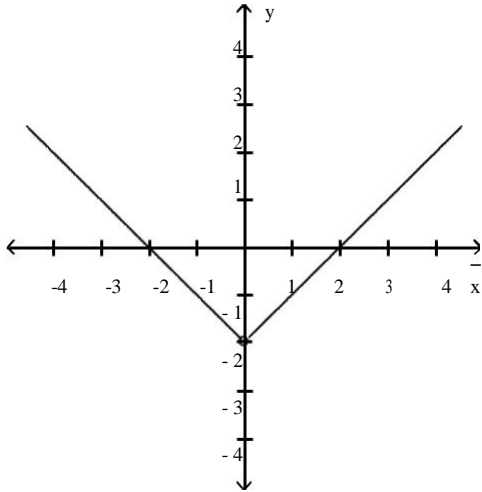

A) -1

B) does not exist

C) 2

D) -2

34) Find $\lim_{x \rightarrow (-1)^-} f(x)$ and $\lim_{x \rightarrow (-1)^+} f(x)$

34) _____

$x \rightarrow (-1)^-$ $x \rightarrow (-1)^+$

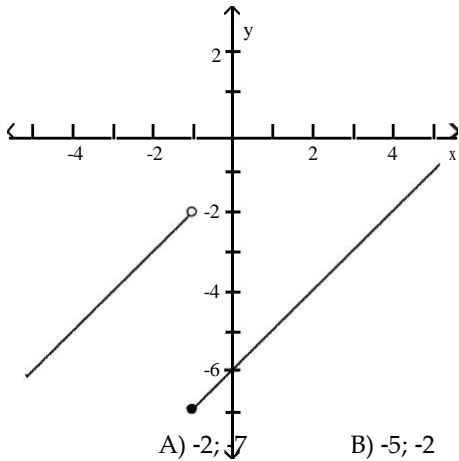

A) -2; -7

B) -5; -2

C) -7; -5

D) -7; -2

Use the table of values of f to estimate the limit.

35) Let $f(x) = x^2 + 8x - 2$, find $\lim_{x \rightarrow 2} f(x)$.

35) _____

x	1.9	1.99	1.999	2.001	2.01	2.1
f(x)						

A)

x	1.9	1.99	1.999	2.001	2.01	2.1
f(x)	16.692	17.592	17.689	17.710	17.808	18.789

; limit = 17.70

B)

x	1.9	1.99	1.999	2.001	2.01	2.1
f(x)	5.043	5.364	5.396	5.404	5.436	5.763

; limit = ∞

C)

x	1.9	1.99	1.999	2.001	2.01	2.1
f(x)	16.810	17.880	17.988	18.012	18.120	19.210

; limit = 18.0

D)

x	1.9	1.99	1.999	2.001	2.01	2.1
f(x)	5.043	5.364	5.396	5.404	5.436	5.763

; limit = 5.40

36) Let $f(x) = \frac{x-4}{\sqrt{x-2}}$, find $\lim_{x \rightarrow 4} f(x)$.

36) _____

x	3.9	3.99	3.999	4.001	4.01	4.1
f(x)						

A)

x	3.9	3.99	3.999	4.001	4.01	4.1
f(x)	1.19245	1.19925	1.19993	1.20007	1.20075	1.20745

; limit = 1.20

B)

x	3.9	3.99	3.999	4.001	4.01	4.1
f(x)	1.19245	1.19925	1.19993	1.20007	1.20075	1.20745

; limit = ∞

C)

x	3.9	3.99	3.999	4.001	4.01	4.1
f(x)	3.97484	3.99750	3.99975	4.00025	4.00250	4.02485

; limit = 4.0

D)

x	3.9	3.99	3.999	4.001	4.01	4.1
f(x)	5.07736	5.09775	5.09978	5.10022	5.10225	5.12236

; limit = 5.10

37) Let $f(x) = x^2 - 5$, find $\lim_{x \rightarrow 0} f(x)$.

37) _____

x	-0.1	-0.01	-0.001	0.001	0.01	0.1
$f(x)$						

A)

x	-0.1	-0.01	-0.001	0.001	0.01	0.1
$f(x)$	-2.9910	-2.9999	-3.0000	-3.0000	-2.9999	-2.9910

; limit = -3.0

B)

x	-0.1	-0.01	-0.001	0.001	0.01	0.1
$f(x)$	-4.9900	-4.9999	-5.0000	-5.0000	-4.9999	-4.9900

; limit = -5.0

C)

x	-0.1	-0.01	-0.001	0.001	0.01	0.1
$f(x)$	-1.4970	-1.4999	-1.5000	-1.5000	-1.4999	-1.4970

; limit = ∞

D)

x	-0.1	-0.01	-0.001	0.001	0.01	0.1
$f(x)$	-1.4970	-1.4999	-1.5000	-1.5000	-1.4999	-1.4970

; limit = -15.0

38) Let $f(x) = \frac{x-5}{x^2 - 8x + 15}$, find $\lim_{x \rightarrow 5} f(x)$.

38) _____

x	4.9	4.99	4.999	5.001	5.01	5.1
$f(x)$						

A)

x	4.9	4.99	4.999	5.001	5.01	5.1
$f(x)$	0.5263	0.5025	0.5003	0.4998	0.4975	0.4762

; limit = 0.5

B)

x	4.9	4.99	4.999	5.001	5.01	5.1
$f(x)$	-0.5263	-0.5025	-0.5003	-0.4998	-0.4975	-0.4762

; limit = -0.5

C)

x	4.9	4.99	4.999	5.001	5.01	5.1
$f(x)$	0.4263	0.4025	0.4003	0.3998	0.3975	0.3762

; limit = 0.4

D)

x	4.9	4.99	4.999	5.001	5.01	5.1
$f(x)$	0.6263	0.6025	0.6003	0.5998	0.5975	0.5762

; limit = 0.6

39) Let $f(x) = \frac{x^2 - 3x + 2}{x^2 + 3x - 10}$, find $\lim_{x \rightarrow 2} f(x)$.

39) _____

x	1.9	1.99	1.999	2.001	2.01	2.1
f(x)						

A)

x	1.9	1.99	1.999	2.001	2.01	2.1
f(x)	0.0304	0.0416	0.0427	0.0430	0.0441	0.0549

; limit = 0.0429

B)

C)

x	1.9	1.99	1.999	2.001	2.01	2.1
f(x)	-1.069	0	-1.0067	-1.0007	-0.9993	-0.9934

; limit = -1

D)

x	1.9	1.99	1.999	2.001	2.01	2.1
f(x)	0.2304	0.2416	0.2427	0.2430	0.2441	0.2549

; limit = 0.2429

D)

x	1.9	1.99	1.999	2.001	2.01	2.1
f(x)	0.1304	0.1416	0.1427	0.1430	0.1441	0.1549

; limit = 0.1429

40) Let $f(x) = \frac{\sin(2x)}{x}$, find $\lim_{x \rightarrow 0} f(x)$.

40) _____

x	-0.1	-0.01	-0.001	0.001	0.01	0.1
f(x)		1.99986667			1.99986667	

A) limit = 1.5

B) limit = 0

C) limit = 2

D) limit does not exist

41) Let $f(\theta) = \frac{\cos(6\theta)}{\theta}$, find $\lim_{\theta \rightarrow 0} f(\theta)$.

41) _____

x	-0.1	-0.01	-0.001	0.001	0.01	0.1
f(θ)	-8.2533561					8.2533561

A) limit = 6

B) limit = 0

C) limit = 8.2533561

D) limit does not exist

SHORT ANSWER. Write the word or phrase that best completes each statement or answers the question. Provide an appropriate response.

42) It can be shown that the inequalities $1 - \frac{x^2}{6} < \frac{x \sin(x)}{2 - 2 \cos(x)} < 1$ hold for all values of x close to zero. What, if anything, does this tell you about $\lim_{x \rightarrow 0} \frac{x \sin(x)}{2 - 2 \cos(x)}$? Explain.

42) _____

MULTIPLE CHOICE. Choose the one alternative that best completes the statement or answers the question.

43) Write the formal notation for the principle "the limit of a quotient is the quotient of the limits" and include a statement of any restrictions on the principle. 43) _____

A) If $\lim_{x \rightarrow a} g(x) = M$ and $\lim_{x \rightarrow a} f(x) = L$, then $\lim_{x \rightarrow a} \frac{g(x)}{f(x)} = \frac{\lim_{x \rightarrow a} g(x)}{\lim_{x \rightarrow a} f(x)} = \frac{M}{L}$, provided that

$L \neq 0$.

B) $\lim_{x \rightarrow a} \frac{g(x)}{f(x)} = \frac{g(a)}{f(a)}$, provided that $f(a) \neq 0$.

C) $\lim_{x \rightarrow a} g(x) = g(a)$.

D) If $\lim_{x \rightarrow a} g(x) = M$ and $\lim_{x \rightarrow a} f(x) = L$, then $\lim_{x \rightarrow a} \frac{g(x)}{f(x)} = \frac{\lim_{x \rightarrow a} g(x)}{\lim_{x \rightarrow a} f(x)} = \frac{M}{L}$, provided that

$f(a) \neq 0$.

44) Provide a short sentence that summarizes the general limit principle given by the formal notation 44) _____

$\lim_{x \rightarrow a} [f(x) \pm g(x)] = \lim_{x \rightarrow a} f(x) \pm \lim_{x \rightarrow a} g(x) = L \pm M$, given that $\lim_{x \rightarrow a} f(x) = L$ and $\lim_{x \rightarrow a} g(x) = M$.

- A) The sum or the difference of two functions is the sum of two limits.
- B) The limit of a sum or a difference is the sum or the difference of the functions.
- C) The sum or the difference of two functions is continuous.
- D) The limit of a sum or a difference is the sum or the difference of the limits.

45) The statement "the limit of a constant times a function is the constant times the limit" follows from a combination of two fundamental limit principles. What are they? 45) _____

- A) The limit of a product is the product of the limits, and a constant is continuous.
- B) The limit of a product is the product of the limits, and the limit of a quotient is the quotient of the limits.
- C) The limit of a function is a constant times a limit, and the limit of a constant is the constant.
- D) The limit of a constant is the constant, and the limit of a product is the product of the limits.

Find the limit.

46) $\lim_{x \rightarrow 20} \sqrt{x-10}$ 46) _____

- A) 10
- B) $\sqrt{10}$
- C) $2\sqrt{5}$
- D) 20

47) $\lim_{x \rightarrow 1} (6x - 4)$ 47) _____

48) $\lim_{x \rightarrow 7} (12 - 10x)$

A) 82

B) 2

B) -82

C) -10

C) -58

D) 10

D) 58

48) _____

Give an appropriate answer.

49) Let $\lim_{x \rightarrow -4} f(x) = -8$ and $\lim_{x \rightarrow -4} g(x) = -5$. Find $\lim_{x \rightarrow -4} [f(x) - g(x)]$. 49) _____

- A) -3 B) -4 C) -8 D) -13

50) Let $\lim_{x \rightarrow -2} f(x) = -10$ and $\lim_{x \rightarrow 2} g(x) = 8$. Find $\lim_{x \rightarrow 2} [f(x) \cdot g(x)]$. 50) _____

- A) -2 B) 8 C) -80 D) 2

51) Let $\lim_{x \rightarrow -5} f(x) = -3$ and $\lim_{x \rightarrow -5} g(x) = 6$. Find $\lim_{x \rightarrow -5} \frac{f(x)}{g(x)}$. 51) _____

- A) $-\frac{1}{2}$ B) $-2\sqrt{\quad}$ C) -5 D) -9

52) Let $\lim_{x \rightarrow 10} f(x) = 64$. Find $\lim_{x \rightarrow 10} \sqrt{f(x)}$. 52) _____

- A) 8 B) 2.8284 C) 64 D) 10

53) Let $\lim_{x \rightarrow 5} f(x) = -2$ and $\lim_{x \rightarrow 5} g(x) = -7$. Find $\lim_{x \rightarrow 5} [f(x) + g(x)]^2$. 53) _____

- A) 81 B) -9 C) 53 D) 5

54) Let $\lim_{x \rightarrow 8} f(x) = 243$. Find $\lim_{x \rightarrow 8} \sqrt[5]{f(x)}$. 54) _____

- A) 3 B) 243 C) 8 D) 5

55) Let $\lim_{x \rightarrow 5} f(x) = -9$ and $\lim_{x \rightarrow 5} g(x) = 1$. Find $\lim_{x \rightarrow 5} \left[\frac{-4f(x) - 8g(x)}{9 + g(x)} \right]$. 55) _____

- A) $\frac{22}{5}$ B) 5 C) -4 D) $\frac{14}{-5}$

Find the limit.

56) $\lim_{x \rightarrow 2} (x^3 + 5x^2 - 7x + 1)$ 56) _____

- A) 15 B) 29 C) does not exist D) 0

57) $\lim_{x \rightarrow -2} (3x^5 - 3x^4 + 4x^3 + x^2 - 5)$ 57) _____

- A) -177 B) -113 C) -81 D) -33

58) $\lim_{x \rightarrow -1} \frac{x}{3x + 2}$ 58) _____

- A) $-\frac{1}{5}$ B) 1 C) does not exist D) 0

59) $\lim_{x \rightarrow 0} \frac{x^3 - 6x + 8}{x - 2}$ 59) _____

- A) Does not exist B) 0 C) -4 D) 4

60) $\lim_{x \rightarrow 1} \frac{3x^2 + 7x - 2}{3x^2 - 4x - 2}$ 60) _____

- A) 0 B) $-\frac{7}{4}$ C) Does not exist D) $-\frac{8}{3}$

61) $\lim_{x \rightarrow 2} (x + 3)^2(x - 1)^3$ 61) _____

- A) 1 B) 27 C) 675 D) 25

62) $\lim_{x \rightarrow 2} \sqrt{x^2 + 2x + 1}$ 62) _____

- A) 3 B) 9 C) ± 3 D) does not exist

63) $\lim_{x \rightarrow 9} \sqrt{4x + 65}$ 63) _____

- A) -101 B) $\sqrt{101}$ C) 101 D) $-\sqrt{101}$

64) $\lim_{h \rightarrow 0} \frac{2}{\sqrt{3h + 4} + 2}$ 64) _____

- A) 1 B) 2 C) 1/2 D) Does not exist

65) $\lim_{x \rightarrow 0} \frac{\sqrt{1+x} - 1}{x}$ 65) _____

- A) 1/2 B) Does not exist C) 1/4 D) 0

Determine the limit by sketching an appropriate graph.

66) $\lim_{x \rightarrow 2^-} f(x)$, where $f(x) = \begin{cases} -2x - 7 & \text{for } x < 2 \\ 4x - 6 & \text{for } x \geq 2 \end{cases}$ 66) _____

- A) -5 B) -6 C) -11 D) 2

67) $\lim_{x \rightarrow 4^+} f(x)$, where $f(x) = \begin{cases} -3x - 4 & \text{for } x < 4 \\ 4x - 3 & \text{for } x \geq 4 \end{cases}$ 67) _____

- A) 13 B) -2 C) -16 D) -3

68) $\lim_{x \rightarrow -4^+} f(x)$, where $f(x) = \begin{cases} x^2 + 3 & \text{for } x \neq -4 \\ 0 & \text{for } x = -4 \end{cases}$ 68) _____

A) 16

B) 13

C) 0

D) 19

69) $\lim_{x \rightarrow 4^-} f(x)$, where $f(x) = \begin{cases} 4 - x^2 & 0 \leq x < 2 \\ 2 & 2 \leq x < 4 \\ 4 & x = 4 \end{cases}$ 69) _____

A) 0 B) Does not exist C) 4 D) 2

70) $\lim_{x \rightarrow -7^+} f(x)$, where $f(x) = \begin{cases} 3x & -7 \leq x < 0, \text{ or } 0 < x \leq 3 \\ 3 & x = 0 \\ 0 & x < -7 \text{ or } x > 3 \end{cases}$ 70) _____

A) -21 B) -0 C) Does not exist D) 5

Find the limit, if it exists.

71) $\lim_{x \rightarrow 0} \frac{x^3 + 12x^2 - 5x}{4}$ 71) _____

A) Does not exist B) 0 C) 5 D) -1

72) $\lim_{x \rightarrow 1} \frac{x - 1}{x - 1}$ 72) _____

A) 0 B) Does not exist C) 4 D) 2

73) $\lim_{x \rightarrow 7} \frac{x - 49}{x - 7}$ 73) _____

A) Does not exist B) 1 C) 14 D) 7

74) $\lim_{x \rightarrow -7} \frac{x^2 + 16x + 63}{x + 7}$ 74) _____

A) 2 B) Does not exist C) 224 D) 16

75) $\lim_{x \rightarrow 6} \frac{x^2 + 4x - 60}{x - 6}$ 75) _____

A) 16 B) Does not exist C) 0 D) 4

76) $\lim_{x \rightarrow 6} \frac{x^2 + 4x - 60}{x^2 - 36}$ 76) _____

A) $\frac{4}{3}$ B) - 3 C) 0 D) Does not exist

77) $\lim_{x \rightarrow 5} \frac{x^2 - 25}{x - 5}$ 77) _____

A) 0

B) $\frac{10}{3}$

C) Does not exist

D) $\frac{5}{3}$

78) $\lim_{x \rightarrow 1} \frac{x^2 + 2x - 3}{x^2 - 4x + 3}$

78) _____

A) - 2

B) 1

C) 2

D) Does not exist

79) $\lim_{h \rightarrow 0} \frac{(x+h)^3 - x^3}{h}$ 79) _____

80) $\lim_{x \rightarrow 6} \frac{6-x}{6-x}$ 80) _____

A) $3x^2$ B) $3x^2 + 3xh + h^2$ C) 0 D) Does not exist

A) 0 B) 1 C) Does not exist D) -1

Provide an appropriate response.

81) It can be shown that the inequalities $-x \leq x \cos\left(\frac{1}{x}\right) \leq x$ hold for all values of $x \geq 0$. 81) _____

Find $\lim_{x \rightarrow 0} x \cos\left(\frac{1}{x}\right)$ if it exists.

82) The inequality $1 - \frac{x^2}{2} < \frac{\sin x}{x} < 1$ holds when x is measured in radians and $|x| < 1$. 82) _____

A) 0.0007 B) does not exist C) 0 D) 1

Find $\lim_{x \rightarrow 0} \frac{\sin x}{x}$ if it exists.

83) If $x^3 \leq f(x) \leq x$ for x in $[-1,1]$, find $\lim_{x \rightarrow 0} f(x)$ if it exists. 83) _____

A) 0 B) 1 C) 0.0007 D) does not exist

A) 0 B) -1 C) 1 D) does not exist

Compute the values of $f(x)$ and use them to determine the indicated limit.

84) If $f(x) = x^2 + 8x - 2$, find $\lim_{x \rightarrow 2} f(x)$. 84) _____

x	1.9	1.99	1.999	2.001	2.01	2.1
f(x)						

A)

x	1.9	1.99	1.999	2.001	2.01	2.1
f(x)	16.810	17.880	17.988	18.012	18.120	19.210

limit = 18.0

B)

x	1.9	1.99	1.999	2.001	2.01	2.1
f(x)	16.692	17.592	17.689	17.710	17.808	18.789

limit = 17.70

C)

x	1.9	1.99	1.999	2.001	2.01	2.1
f(x)	5.043	5.364	5.396	5.404	5.436	5.763

limit = 5.40

D)

x	1.9	1.99	1.999	2.001	2.01	2.1
f(x)	5.043	5.364	5.396	5.404	5.436	5.763

limit = ∞

85) If $f(x) = \frac{x^4 - 1}{x - 1}$, find $\lim_{x \rightarrow 1} f(x)$.

85) _____

x	0.9	0.99	0.999	1.001	1.01	1.1
f(x)						

A)

x	0.9	0.99	0.999	1.001	1.01	1.1
f(x)	3.439	3.940	3.994	4.006	4.060	4.641

; limit = 4.0

B)

x	0.9	0.99	0.999	1.001	1.01	1.1
f(x)	1.032	1.182	1.198	1.201	1.218	1.392

; limit = ∞

C)

x	0.9	0.99	0.999	1.001	1.01	1.1
f(x)	4.595	5.046	5.095	5.105	5.154	5.677

; limit = 5.10

D)

x	0.9	0.99	0.999	1.001	1.01	1.1
f(x)	1.032	1.182	1.198	1.201	1.218	1.392

; limit = 1.210

86) If $f(x) = \frac{x^3 - 6x + 8}{x - 2}$, find $\lim_{x \rightarrow 0} f(x)$.

86) _____

x	-0.1	-0.01	-0.001	0.001	0.01	0.1
f(x)						

A)

x	-0.1	-0.01	-0.001	0.001	0.01	0.1
f(x)	-1.22843	-1.20298	-1.20030	-1.19970	-1.19699	-1.16858

; limit = ∞

B)

x	-0.1	-0.01	-0.001	0.001	0.01	0.1
f(x)	-1.22843	-1.20298	-1.20030	-1.19970	-1.19699	-1.16858

; limit = -1.20

C)

x	-0.1	-0.01	-0.001	0.001	0.01	0.1
f(x)	-4.09476	-4.00995	-4.00100	-3.99900	-3.98995	-3.89526

; limit = -4.0

D)

x	-0.1	-0.01	-0.001	0.001	0.01	0.1
f(x)	-2.18529	-2.10895	-2.10090	-2.99910	-2.09096	-2.00574

; limit = -2.10

87) If $f(x) = \frac{x-4}{\sqrt{x}-2}$, find $\lim_{x \rightarrow 4} f(x)$.

87) _____

x	3.9	3.99	3.999	4.001	4.01	4.1
f(x)						

A)

x	3.9	3.99	3.999	4.001	4.01	4.1
f(x)	1.19245	1.19925	1.19993	1.20007	1.20075	1.20745

; limit = 1.20

B)

x	3.9	3.99	3.999	4.001	4.01	4.1
f(x)	3.97484	3.99750	3.99975	4.00025	4.00250	4.02485

; limit = 4.0

C)

x	3.9	3.99	3.999	4.001	4.01	4.1
f(x)	1.19245	1.19925	1.19993	1.20007	1.20075	1.20745

; limit = ∞

D)

x	3.9	3.99	3.999	4.001	4.01	4.1
f(x)	5.07736	5.09775	5.09978	5.10022	5.10225	5.12236

; limit = 5.10

88) If $f(x) = x^2 - 5$, find $\lim_{x \rightarrow 0} f(x)$.

88) _____

x	-0.1	-0.01	-0.001	0.001	0.01	0.1
f(x)						

A)

x	-0.1	-0.01	-0.001	0.001	0.01	0.1
f(x)	-2.9910	-2.9999	-3.0000	-3.0000	-2.9999	-2.9910

; limit = -3.0

B)

x	-0.1	-0.01	-0.001	0.001	0.01	0.1
f(x)	-1.4970	-1.4999	-1.5000	-1.5000	-1.4999	-1.4970

; limit = -15.0

C)

x	-0.1	-0.01	-0.001	0.001	0.01	0.1
f(x)	-1.4970	-1.4999	-1.5000	-1.5000	-1.4999	-1.4970

; limit = ∞

D)

x	-0.1	-0.01	-0.001	0.001	0.01	0.1
f(x)	-4.9900	-4.9999	-5.0000	-5.0000	-4.9999	-4.9900

; limit = -5.0

89) If $f(x) = \frac{\sqrt{x+1}}{x+1}$, find $\lim_{x \rightarrow 1} f(x)$.

89) _____

x	0.9	0.99	0.999	1.001	1.01	1.1
f(x)						

A)

x	0.9	0.99	0.999	1.001	1.01	1.1
f(x)	2.15293	2.13799	2.13656	2.13624	2.13481	2.12106

; limit = 2.13640

B)

x	0.9	0.99	0.999	1.001	1.01	1.1
f(x)	0.72548	0.70888	0.70728	0.70693	0.70535	0.69007

; limit = 0.7071

C)

x	0.9	0.99	0.999	1.001	1.01	1.1
f(x)	0.21764	0.21266	0.21219	0.21208	0.21160	0.20702

; limit = ∞

D)

x	0.9	0.99	0.999	1.001	1.01	1.1
f(x)	0.21764	0.21266	0.21219	0.21208	0.21160	0.20702

; limit = 0.21213

90) If $f(x) = \sqrt{x-2}$, find $\lim_{x \rightarrow 4} f(x)$.

90) _____

x	3.9	3.99	3.999	4.001	4.01	4.1
f(x)						

A)

x	3.9	3.99	3.999	4.001	4.01	4.1
f(x)	-0.02516	-0.00250	-0.00025	0.00025	0.00250	0.02485

; limit = 0

B)

x	3.9	3.99	3.999	4.001	4.01	4.1
f(x)	3.9000	2.9000	1.9000	2.0000	3.0000	4.0000

; limit = 1.95

C)

x	3.9	3.99	3.999	4.001	4.01	4.1
f(x)	1.47736	1.49775	1.49977	1.50022	1.50225	1.52236

; limit = ∞

D)

x	3.9	3.99	3.999	4.001	4.01	4.1
f(x)	1.47736	1.49775	1.49977	1.50022	1.50225	1.52236

; limit = 1.50

For the function f whose graph is given, determine the limit.

91) Find $\lim_{x \rightarrow 5^-} f(x)$ and $\lim_{x \rightarrow 5^+} f(x)$.

91) _____

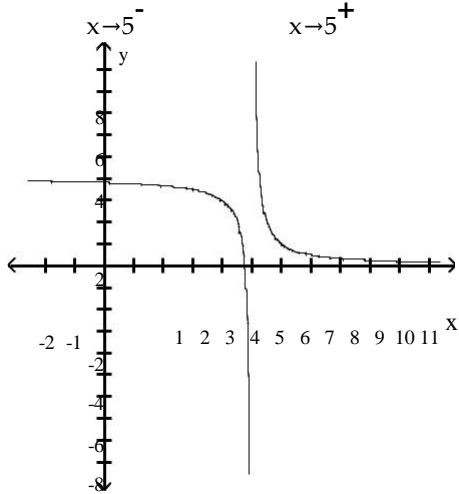

A) $-5, 5$

B) $\infty, -\infty$

C) $-\infty, \infty$

D) $5; 5$

92) Find $\lim_{x \rightarrow 2^-} f(x)$ and $\lim_{x \rightarrow 2^+} f(x)$.

92) _____

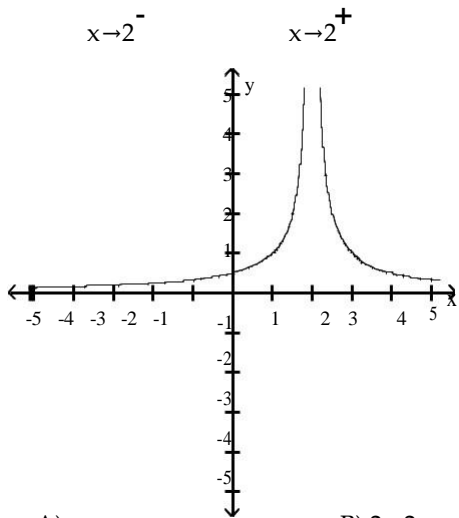

A) $\infty; \infty$

B) $2; -2$

C) $0; 1$

D) $-\infty; \infty$

93) Find $\lim_{x \rightarrow 3} f(x)$.

93) _____

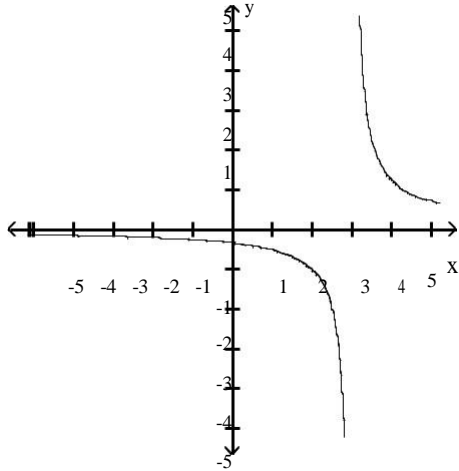

A) $-\infty$

B) 3

C) ∞

D) does not exist

94) Find $\lim_{x \rightarrow -3} f(x)$.

94) _____

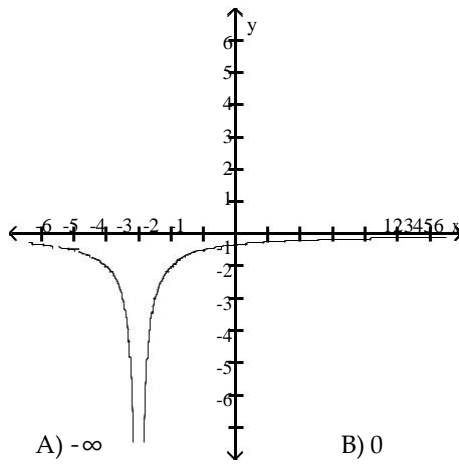

A) $-\infty$

B) 0

C) -3

D) ∞

95) Find $\lim_{x \rightarrow 0} f(x)$.

95) _____

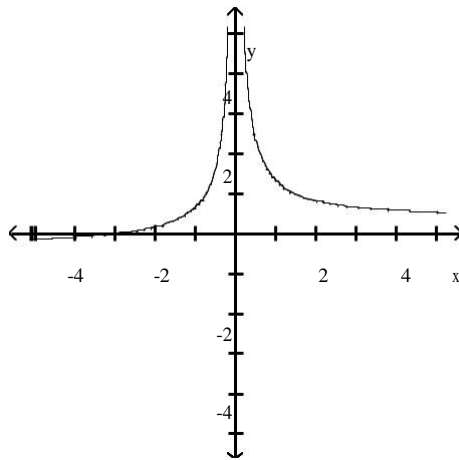

A) ∞

B) 0

C) 1

D) $-\infty$

Find the limit.

96) $\lim_{x \rightarrow -2} \frac{1}{x+2}$ 96) _____

$x \rightarrow -2$ $x+2$

- A) Does not exist B) ∞ C) $-\infty$ D) 1/2

97) $\lim_{x \rightarrow -3} \frac{1}{x+3}$ 97) _____

$x \rightarrow -3$ $x+3$

- A) ∞ B) 0 C) $-\infty$ D) -1

98) $\lim_{x \rightarrow 3} \frac{1}{(x-3)^2}$ 98) _____

$x \rightarrow 3$ $(x-3)^2$

- A) $-\infty$ B) 0 C) -1 D) ∞

99) $\lim_{x \rightarrow -3} \frac{7}{x^2-9}$ 99) _____

$x \rightarrow -3$ x^2-9

- A) -1 B) 0 C) ∞ D) $-\infty$

100) $\lim_{x \rightarrow 4^+} \frac{1}{x-16}$ 100) _____

$x \rightarrow 4^+$ $x-16$

- A) $-\infty$ B) 0 C) 1 D) ∞

101) $\lim_{x \rightarrow (\pi/2)^+} \tan x$ 101) _____

$x \rightarrow (\pi/2)^+$

- A) 0 B) ∞ C) 1 D) $-\infty$

102) $\lim_{x \rightarrow (-\pi/2)^-} \sec x$ 102) _____

$x \rightarrow (-\pi/2)^-$

- A) 0 B) ∞ C) $-\infty$ D) 1

103) $\lim_{x \rightarrow 0^+} (1 + \csc x)$ 103) _____

$x \rightarrow 0^+$

- A) ∞ B) 1 C) 0 D) Does not exist

104) $\lim_{x \rightarrow 0} (1 - \cot x)$ 104) _____

$x \rightarrow 0$

- A) ∞ B) $-\infty$ C) 0 D) Does not exist

105) $\lim_{x \rightarrow -2^+} \frac{x^2-7x+10}{x^3-4x}$ 105) _____

$x \rightarrow -2^+$ x^3-4x

- A) 0 B) $-\infty$ C) Does not exist D) ∞

106) $\lim_{x \rightarrow 2^+} \frac{x^2-5x+6}{x^3-9x}$ 106) _____

$x \rightarrow 2^+$ x^3-9x

A) $-\infty$

B) ∞

C) Does not exist

D) 0

Find all vertical asymptotes of the given function.

107) $f(x) = \frac{3x}{x+4}$ 107) _____
 A) $x = 4$ B) $x = 3$ C) $x = -4$ D) none

108) $f(x) = \frac{x+5}{x^2-64}$ 108) _____
 A) $x = 64, x = -5$ B) $x = 0, x = 64$
 C) $x = -8, x = 8$ D) $x = -8, x = 8, x = -5$

109) $g(x) = \frac{x+5}{x^2+1}$ 109) _____
 A) $x = -1, x = 1$ B) $x = -1, x = -5$
 C) $x = -1, x = 1, x = -5$ D) none

110) $f(x) = \frac{x+11}{x^2+25x}$ 110) _____
 A) $x = -5, x = 5$ B) $x = 0, x = -25$
 C) $x = -25, x = -11$ D) $x = 0, x = -5, x = 5$

111) $f(x) = \frac{x-1}{x^3+16x}$ 111) _____
 A) $x = 0$ B) $x = 0, x = -4, x = 4$
 C) $x = 0, x = -16$ D) $x = -4, x = 4$

112) $R(x) = \frac{-3x^2}{x^2+4x-21}$ 112) _____
 A) $x = -7, x = 3$ B) $x = -7, x = 3, x = -3$
 C) $x = -21$ D) $x = 7, x = -3$

113) $R(x) = \frac{x-1}{x^3+3x^2-28x}$ 113) _____
 A) $x = -4, x = -30, x = 7$ B) $x = -4, x = 0, x = 7$
 C) $x = -7, x = 4$ D) $x = -7, x = 0, x = 4$

114) $f(x) = \frac{-2x(x+2)}{2x^2-5x-7}$ 114) _____
 A) $x = -\frac{2}{7}, x = 1$ B) $x = -\frac{7}{2}, x = 1$ C) $x = \frac{2}{7}, x = -1$ D) $x = \frac{7}{2}, x = -1$

115) $f(x) = \frac{x-3}{9x-x^3}$ 115) _____
 A) $x = -3, x = 3$ B) $x = 0, x = -3, x = 3$
 C) $x = 0, x = -3$ D) $x = 0, x = 3$

$$116) f(x) = \frac{-x^2 + 16}{x^2 + 5x + 4}$$

116) _____

A) $x = 1, x = -4$

B) $x = -1, x = 4$

C) $x = -1$

D) $x = -1, x = -4$

Choose the graph that represents the given function without using a graphing utility.

_____x

117) _____

$$117) f(x) = x + 2$$

A)

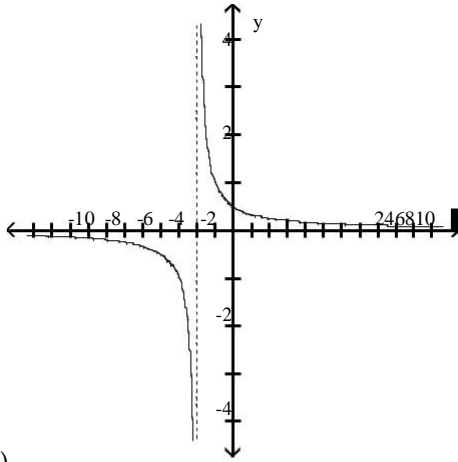

B)

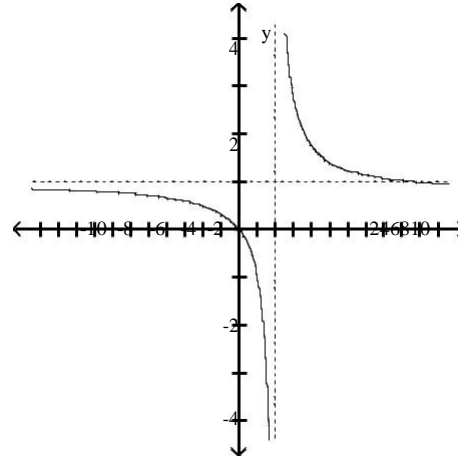

C)

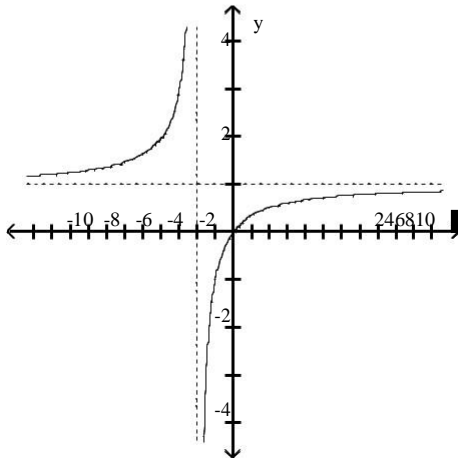

D)

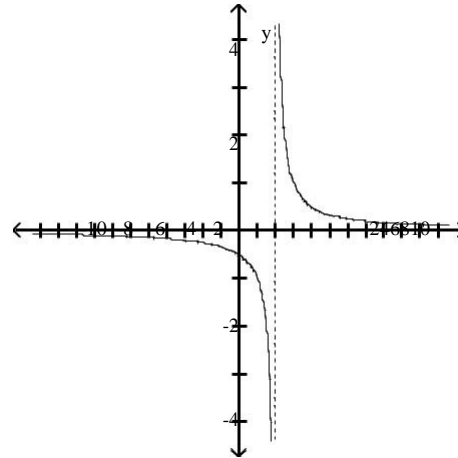

118) $f(x) = \frac{x}{x^2 + x + 2}$

118) _____

A)

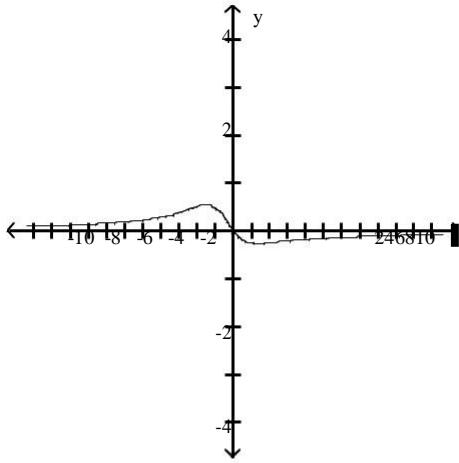

B)

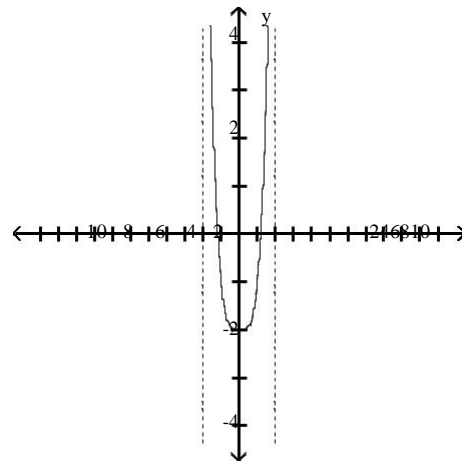

C)

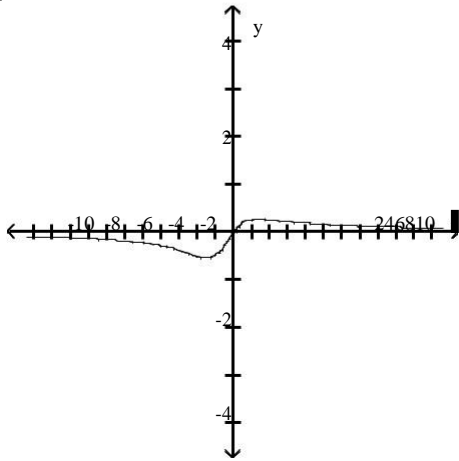

D)

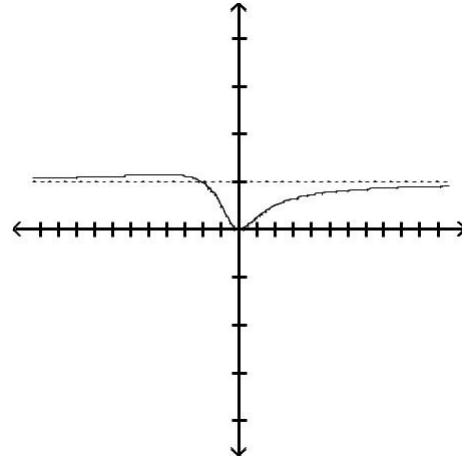

119) $f(x) = \frac{x^2 - 3}{x^3}$

119) _____

A)

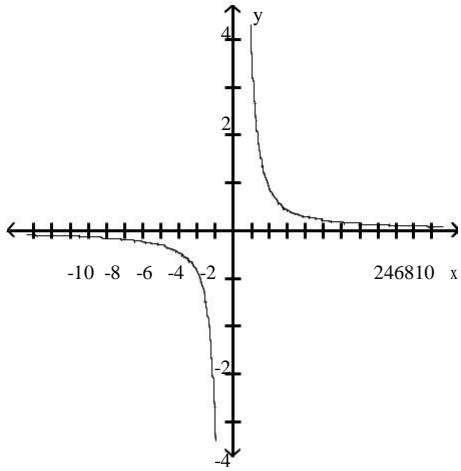

B)

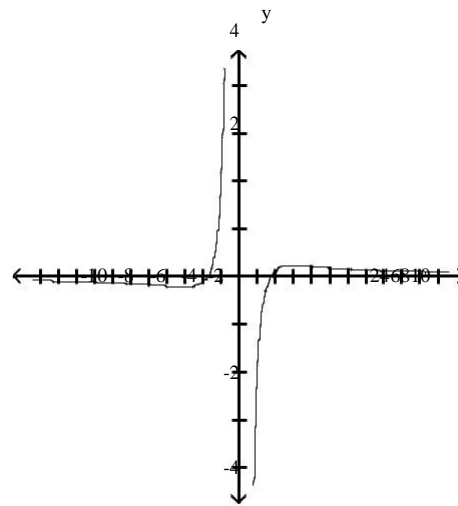

C)

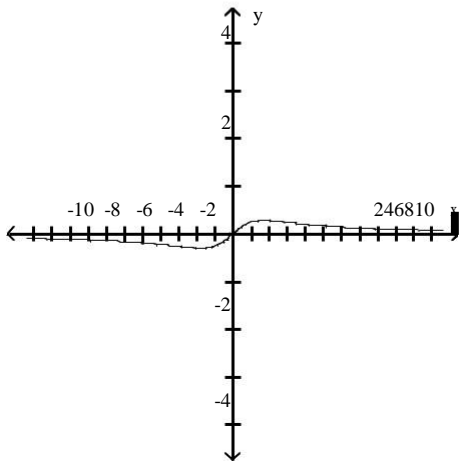

D)

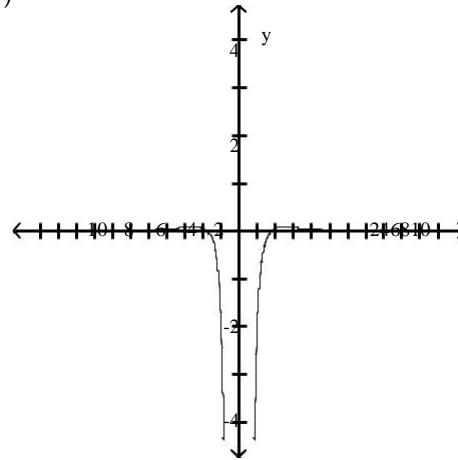

120) $f(x) = \frac{1}{x+1}$
 A)

120) _____

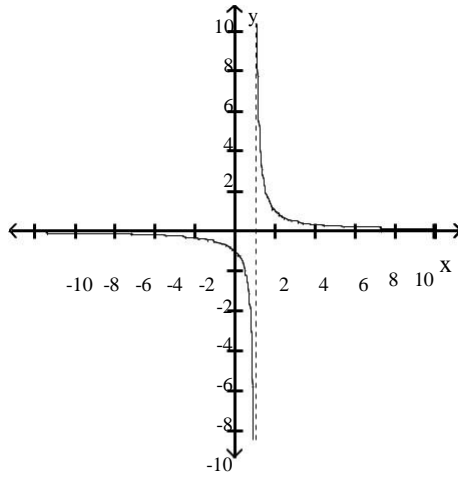

B)

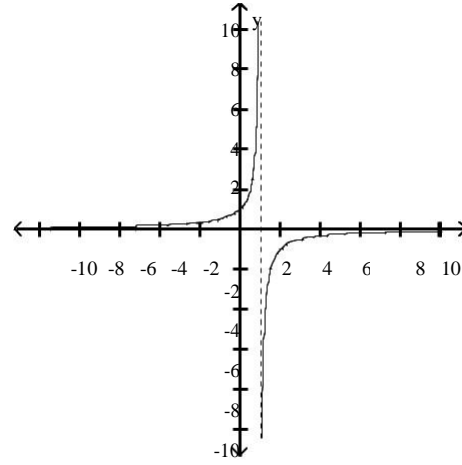

C)

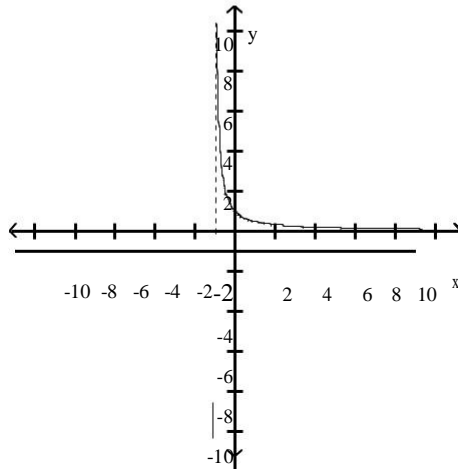

D)

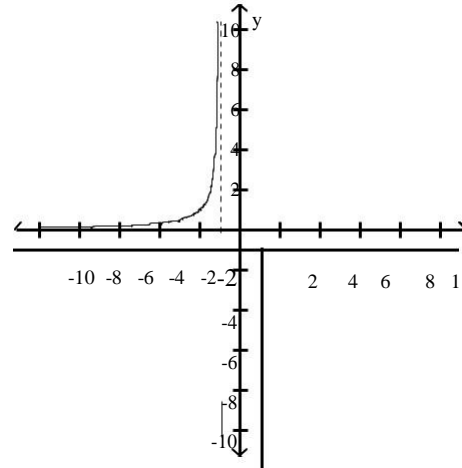

121) $f(x) = \frac{x-1}{x+1}$

121) _____

A)

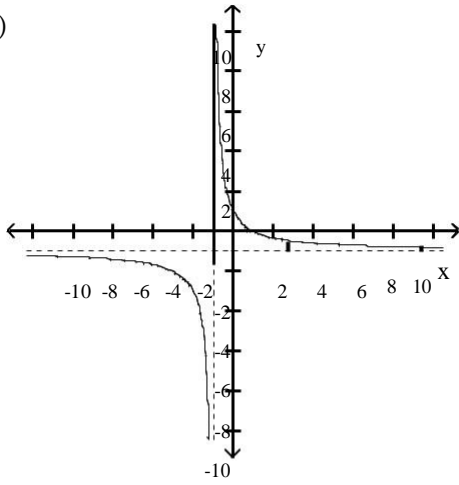

B)

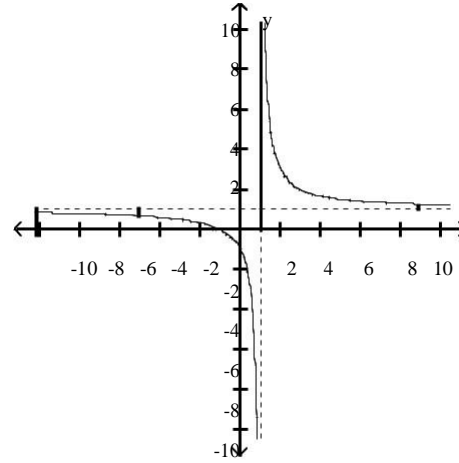

C)

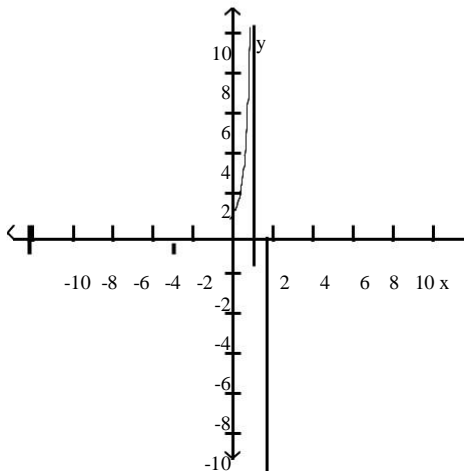

D)

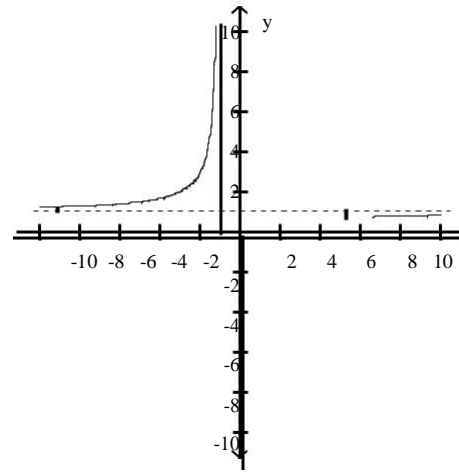

122) $f(x) = \frac{1}{(x+2)^2}$

122) _____

A)

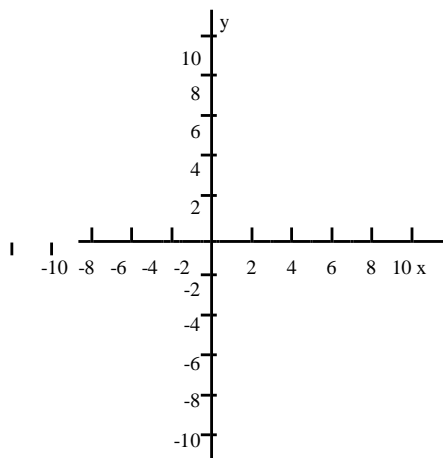

B)

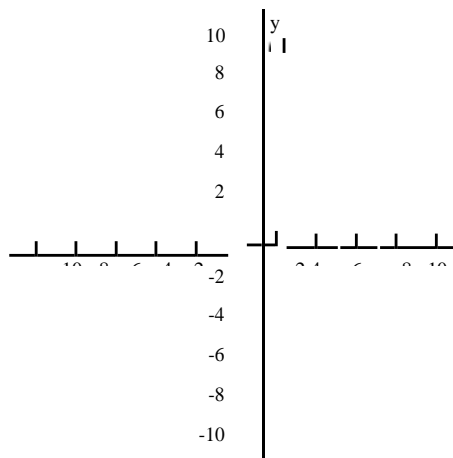

C)

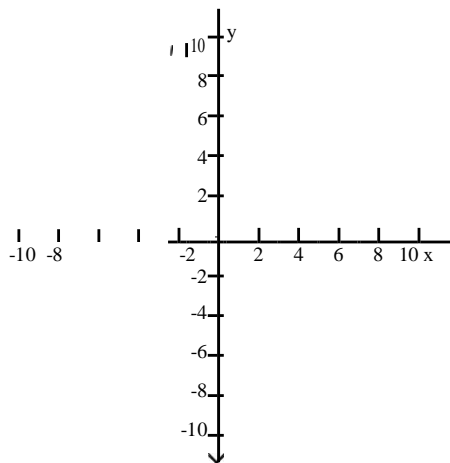

D)

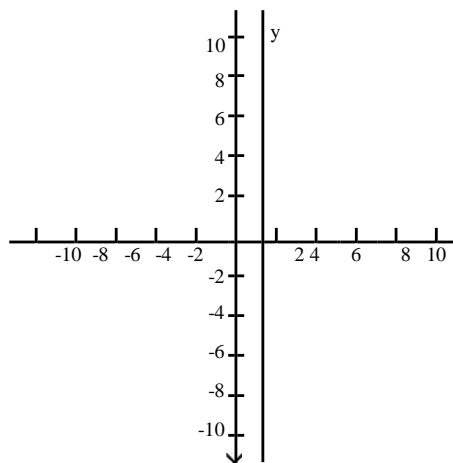

123) $f(x) = \frac{2x^2}{4-x^2}$

123) _____

A)

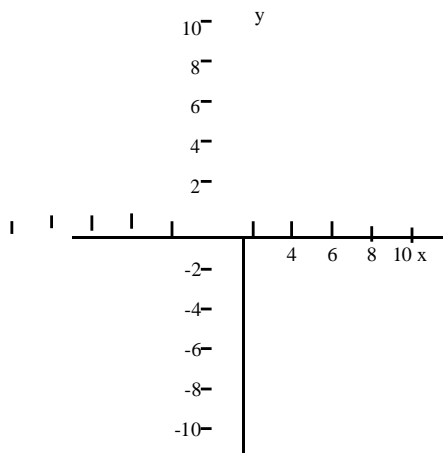

B)

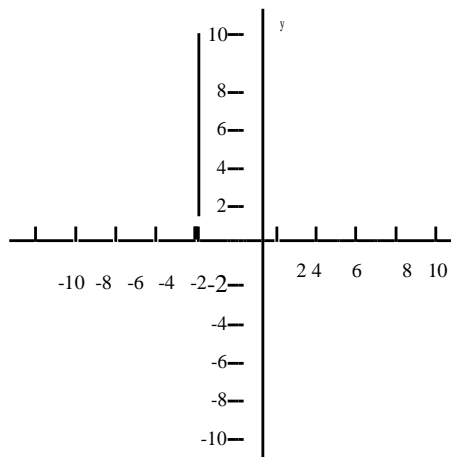

C)

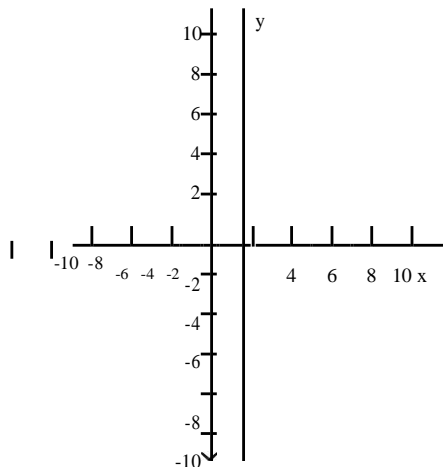

D)

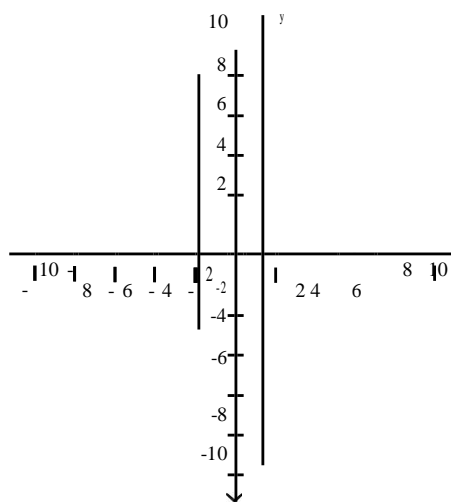

Find the limit.

124) $\lim_{x \rightarrow -\infty} (-2x^{18} + 10)$

124) _____

A) $-\infty$

B) ∞

C) 0

D) 10

125) $\lim_{x \rightarrow -\infty} 4x^{-7}$

125) _____

A) -4

B) $-\infty$

C) 0

D) ∞

126) $\lim_{x \rightarrow \infty} 2x^8 - 15x^6$

126) _____

A) -13

B) ∞

C) $-\infty$

D) 0

127) $\lim_{x \rightarrow \infty} \frac{1}{x} - 3$

127) _____

A) -4

B) -3

C) 3

D) -2

- 128) $\lim_{x \rightarrow -\infty} \frac{1}{6 - (9/x^2)}$ 128) _____
 A) 1 B) $-\sqrt[3]{1}$ C) $-\infty$ D) 6
- 129) $\lim_{x \rightarrow -\infty} \frac{-5 + (4/x)}{7 - (1/x^2)}$ 129) _____
 A) ∞ B) $-\infty$ C) $-\frac{5}{7}$ D) 7
- 130) $\lim_{x \rightarrow \infty} \frac{x^2 - 5x + 16}{x^3 + 6x^2 + 19}$ 130) _____
 A) ∞ B) 1 C) 19 D) 0
- 131) $\lim_{x \rightarrow -\infty} \frac{-7x^2 + 7x + 2}{-16x^2 - 7x + 8}$ 131) _____
 A) 1 B) $\frac{1}{4}$ C) ∞ D) 7
- 132) $\lim_{x \rightarrow \infty} \frac{5x + 1}{7x - 7}$ 132) _____
 A) ∞ B) 0 C) $\frac{5}{7}$ D) $-\frac{1}{7}$
- 133) $\lim_{x \rightarrow \infty} \frac{3x^3 - 5x^2 + 3x}{-x^3 - 2x + 6}$ 133) _____
 A) $\frac{3}{2}$ B) -3 C) 3 D) ∞
- 134) $\lim_{x \rightarrow -\infty} \frac{4x^3 + 3x^2}{x - 5x^2}$ 134) _____
 A) ∞ B) $-\frac{3}{5}$ C) $-\infty$ D) 4
- 135) $\lim_{x \rightarrow -\infty} \frac{\cos 4x}{x}$ 135) _____
 A) 4 B) 1 C) 0 D) $-\infty$

and denominator by the highest power of x in the denominator to find the limit.

136) $\lim_{x \rightarrow \infty} \frac{\sqrt{16x^2}}{7 + 49x^2}$
 A) ~~49~~ B) ~~-7~~ C) ~~7~~ D) $-\infty$

137) $\lim_{x \rightarrow \infty} \frac{\sqrt{9x^2 + x - 3}}{(x - 7)(x + 1)}$
 A) 9 B) 0 C) ∞ D) 5

138) $\lim_{x \rightarrow \infty} \frac{-3\sqrt{x} - 1}{-5x + 4}$
 A) ∞ B) 0 C) $-\frac{1}{5}$ D) 5

139) $\lim_{x \rightarrow \infty} \frac{2x^{-1} + 5x^{-3}}{4x^{-2} + x^{-5}}$
 A) ~~2~~ B) 0 C) ∞ D) 64

140) $\lim_{x \rightarrow -\infty} \frac{\sqrt[3]{x + 2x + 6}}{5x + x^{2/3} + 7}$
 A) 5 B) $\frac{5}{2}$ C) 0 D) 0

141) $\lim_{t \rightarrow \infty} \frac{\sqrt{25t^2 - 125}}{t - 5}$
 A) 125 B) does not exist C) 25 D) 3

142) $\lim_{t \rightarrow \infty} \frac{\sqrt{64t^2 - 512}}{t - 8}$
 A) 512 B) does not exist C) 8 D) 5

143) $\lim_{x \rightarrow \infty} \frac{\sqrt{6x^2 + 1}}{7x + 6}$
 A) 6 B) $\frac{7}{\sqrt{6}}$ C) ∞ D) 5

E) 144) $h(x) =$ D) $-\infty$

Find a

$$\frac{8x - 6}{x - 3}$$

3
C) $y = 8$

B) $y = 0$
D) no horizontal asymptotes

144)

145) $h(x) = 7 \cdot 3^{-x}$

- A) $x = 0$
- C) $y = 7$

- B) $y = 3$
- D) no horizontal asymptotes

145) _____

146) $g(x) = \frac{x^2 + 6x - 2}{x - 2}$

- A) $y = 0$
- C) $y = 1$

- B) $y = 2$
- D) no horizontal asymptotes

146) _____

147) $h(x) = \frac{3x^2 - 3x - 4}{4x^2 - 6x + 5}$

- A) $y = 0$
- C) $y = \frac{3}{4}$

- B) $y = \frac{1}{2}$
- D) no horizontal asymptotes

147) _____

148) $h(x) = \frac{9x^4 - 5x^2 - 6}{5x^5 - 8x + 4}$

- A) $y = \frac{5}{8}$

- B) $y = 0$

148) _____

- C) $y = \frac{9}{5}$

- D) no horizontal asymptotes

149) $h(x) = \frac{9x^3 - 4x}{8x^3 - 8x + 4}$

- A) $y = 8$
- C) $y = 0$

- B) $y = \frac{1}{2}$
- D) no horizontal asymptotes

149) _____

150) $h(x) = \frac{4x^3 - 8x - 2}{8x^2 + 7}$

- A) $y = 2$
- C) $y = 0$

- B) $y = 4$
- D) no horizontal asymptotes

150) _____

151) $g(x) = \frac{7x + 1}{x - 16}$

- A) $y = 0$
- C) $y = 7$

- B) no horizontal asymptotes
- D) $y = -4, y = 4$

151) _____

$$152) R(x) = \frac{-3x^2 + 1}{x^2 + 8x - 33}$$

152) _____

- A) $y = 0$
 C) $y = -3$

- B) $y = -11, y = 3$
 D) no horizontal asymptotes

$$153) f(x) = \frac{x^2 - 5}{25x - x^4}$$

153) _____

- A) $y = -1$
 C) no horizontal asymptotes

- B) $y = -5, y = 5$
 D) $y = 0$

$$154) f(x) = \frac{36x^4 + x^2}{x - x^3} - 6$$

154) _____

- A) $y = -1, y = 1$
 C) $y = -36$

- B) no horizontal asymptotes
 D) $y = 0$

SHORT ANSWER. Write the word or phrase that best completes each statement or answers the question.

Sketch the graph of a function $y = f(x)$ that satisfies the given conditions.

$$155) f(0) = 0, f(1) = 4, f(-1) = -4, \lim_{x \rightarrow -\infty} f(x) = -3, \lim_{x \rightarrow \infty} f(x) = 3.$$

155) _____

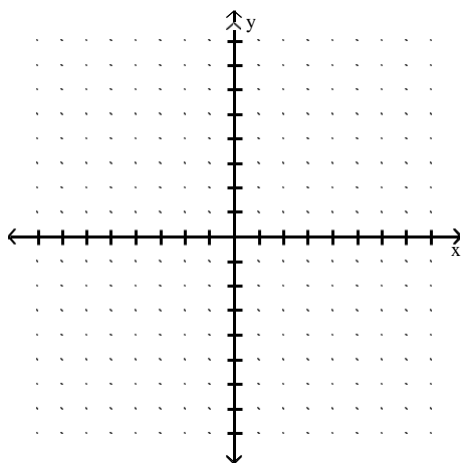

$$156) f(0) = 0, f(1) = 5, f(-1) = 5, \lim_{x \rightarrow \pm \infty} f(x) = -5.$$

156) _____

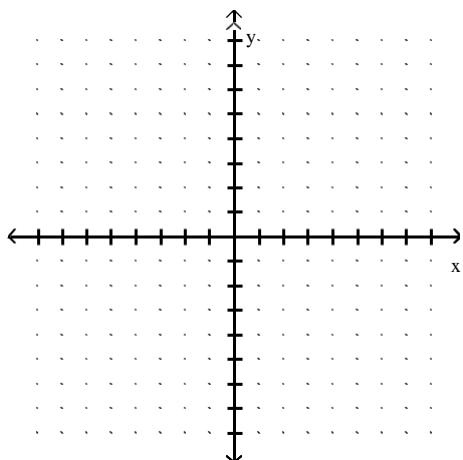

157) $f(0) = 5, f(1) = -5, f(-1) = -5, \lim_{x \rightarrow \pm \infty} f(x) = 0.$

157) _____

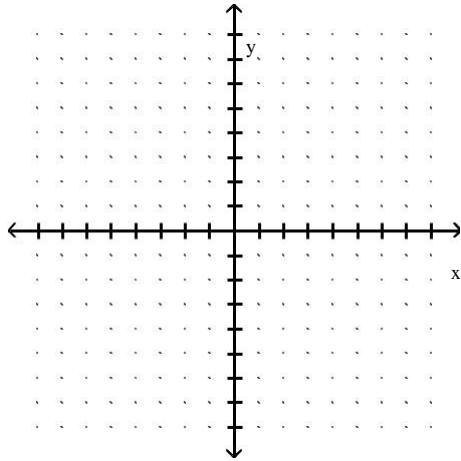

158) $f(0) = 0, \lim_{x \rightarrow \pm \infty} f(x) = 0, \lim_{x \rightarrow 4^-} f(x) = -\infty, \lim_{x \rightarrow 4^+} f(x) = -\infty, \lim_{x \rightarrow 4^+} f(x) = \infty,$
 $\lim_{x \rightarrow 4^-} f(x) = \infty.$

158) _____

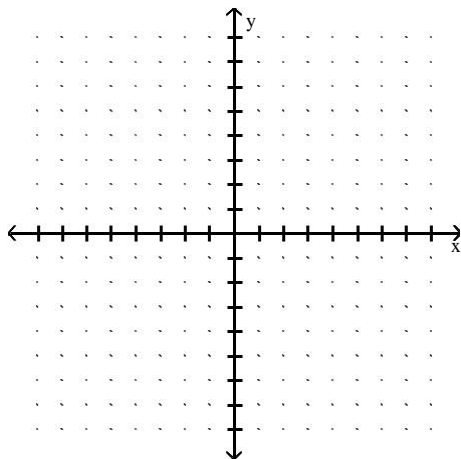

MULTIPLE CHOICE. Choose the one alternative that best completes the statement or answers the question. Find the requested asymptote(s) of the given function.

159) $f(x) = \frac{x+3}{x^2-4}$; Find the vertical asymptote(s).

159) _____

- A) $x = -2, x = 2, x = -3$
- C) $x = -2, x = 2$

- B) $x = 0, x = 4$
- D) $x = 4, x = -3$

160) $f(x) = \frac{x+7}{x^2+1}$; Find the vertical asymptote(s).

160) _____

- A) $x = -1, x = 1$
- C) none

- B) $x = -1, x = 1, x = -7$
- D) $x = -1, x = -7$

161) $h(x) = \frac{x+11}{x^2+25x}$; Find the vertical asymptote(s).

161) _____

- A) $x = 0, x = -25$
 C) $x = -5, x = 5$

- B) $x = -25, x = -11$
 D) $x = 0, x = -5, x = 5$

162) $f(x) = \frac{-3x^2}{x^2+4x-32}$; Find the vertical asymptote(s).

162) _____

- A) $x = -8, x = 4$
 C) $x = 8, x = -4$

- B) $x = -8, x = 4, x = -3$
 D) $x = -32$

163) $f(x) = \frac{x-1}{x^3+7x^2-60x}$; Find the vertical asymptote(s).

163) _____

- A) $x = -5, x = -30, x = 12$
 C) $x = -12, x = 5$

- B) $x = -12, x = 0, x = 5$
 D) $x = -5, x = 0, x = 12$

164) $f(x) = \frac{24x^2+22x+6}{4x+1}$; Find the slant asymptote.

164) _____

A) $y = 6x + 6$

B) $y = 6x + 4$

C) $y = 6x$

D) $y = 4x + 1$

165) $f(x) = \frac{8x^3+4x^2+11x+4}{1+x^2}$; Find the slant asymptote.

165) _____

A) $y = 1 + x^2$

B) $y = 8x$

C) $y = 8x + 11$

D) $y = 8x + 4$

Find all points where the function is discontinuous.

166)

166) _____

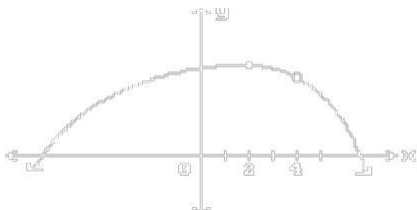

A) None

B) $x = 4$

C) $x = 2$

D) $x = 4, x = 2$

167)

167) _____

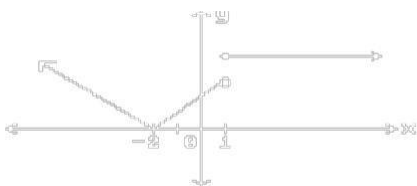

A) $x = -2, x = 1$

B) None

C) $x = 1$

D) $x = -2$

168)

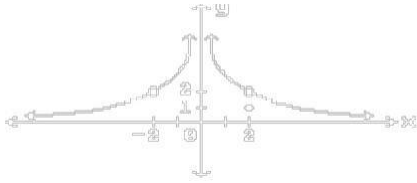

- A) $x = -2, x = 0$
- C) $x = 0, x = 2$

- B) $x = -2, x = 0, x = 2$
- D) $x = 2$

168) _____

169)

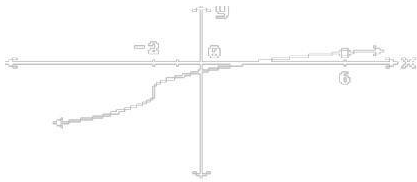

A) None

B) $x = -2$

C) $x = -2, x = 6$

D) $x = 6$

169) _____

170)

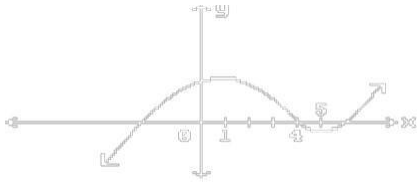

- A) $x = 1, x = 4, x = 5$
- C) $x = 1, x = 5$

- B) None
- D) $x = 4$

170) _____

171)

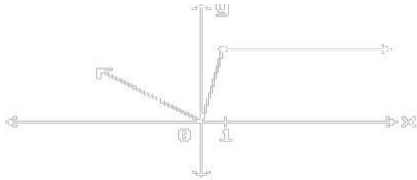

A) $x = 1$

B) $x = 0$

C) None

D) $x = 0, x = 1$

171) _____

172)

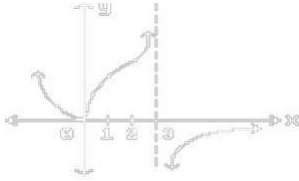

A) $x = 0$

B) $x = 3$

C) $x = 0, x = 3$

D) None

172) _____

173)

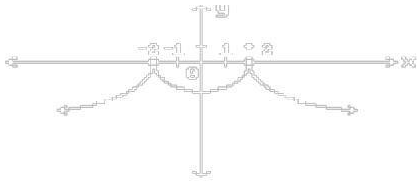

A) $x = -2$

B) None

C) $x = -2, x = 2$

D) $x = 2$

173) _____

174)

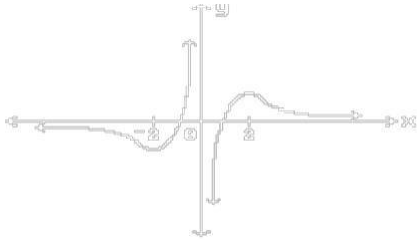

A) $x = -2, x = 0, x = 2$

C) None

B) $x = -2, x = 2$

D) $x = 0$

174) _____

Provide an appropriate response.

175) Is f continuous at $f(1)$?

$$f(x) = \begin{cases} -x^2 + 1, & -1 \leq x < 0 \\ 5x, & 0 < x < 1 \\ -5, & x = 1 \\ -5x + 10, & 1 < x < 3 \\ 2, & 3 < x < 5 \end{cases}$$

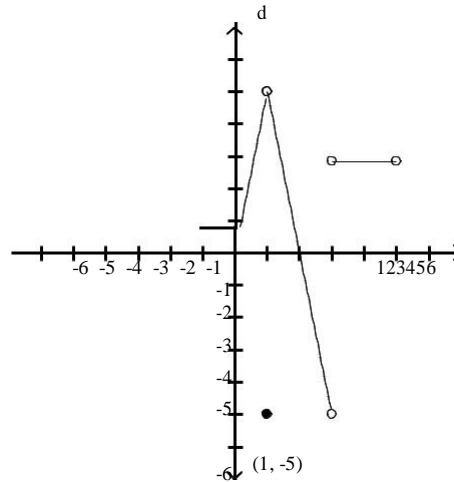

A) Yes

B) No

175) _____

176) Is f continuous at $f(0)$?

176) _____

$$f(x) = \begin{cases} -x^2 + 1, & -1 \leq x < 0 \\ 2x, & 0 < x < 1 \\ -5, & x = 1 \\ -2x + 4, & 1 < x < 3 \\ 1, & 3 < x < 5 \end{cases}$$

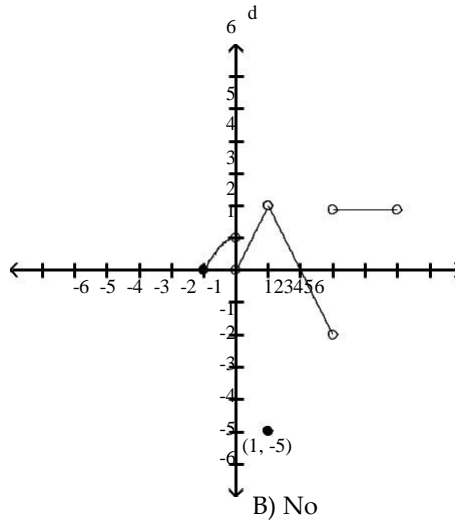

A) Yes

B) No

177) Is f continuous at $x = 0$?

177) _____

$$f(x) = \begin{cases} x^3, & -2 < x \leq 0 \\ -4x, & 0 \leq x < 2 \\ 7, & 2 < x \leq 4 \\ 0, & x = 2 \end{cases}$$

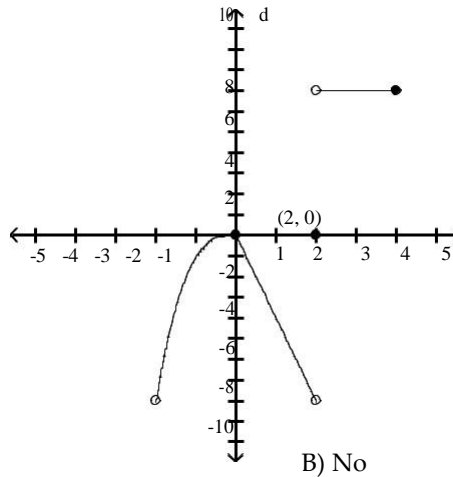

A) Yes

B) No

178) Is f continuous at $x = 4$?

178) _____

$$f(x) = \begin{cases} x^3, & -2 < x \leq 0 \\ -4x, & 0 \leq x < 2 \\ 5, & 2 < x \leq 4 \\ 0, & x = 2 \end{cases}$$

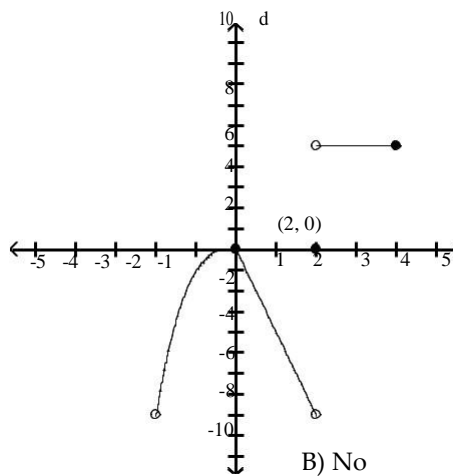

A) Yes

B) No

179) Is the function given by $f(x) = \frac{x+1}{x^2 - 8x + 12}$ continuous at $x = 2$? Why or why not? 179) _____

A) Yes, $\lim_{x \rightarrow 2} f(x) = f(2)$

B) No, $f(2)$ does not exist and $\lim_{x \rightarrow 2} f(x)$ does not exist

180) Is the function given by $f(x) = \sqrt[9]{10x+9}$ continuous at $x = -10$? Why or why not? 180) _____

A) No, $\lim_{x \rightarrow -10} f(x)$ does not exist

B) Yes, $\lim_{x \rightarrow -10} f(x) = f(-10)$

181) Is the function given by $f(x) = \begin{cases} x^2 - 4, & \text{for } x < 0 \\ -2, & \text{for } x \geq 0 \end{cases}$ continuous at $x = -2$? Why or why not? 181) _____

A) Yes, $\lim_{x \rightarrow -2} f(x) = f(-2)$

B) No, $\lim_{x \rightarrow -2} f(x) = f(-2)$ does not exist

182) Is the function given by $f(x) = \begin{cases} \frac{1}{x-3}, & \text{for } x > 3 \\ x + 4x, & \text{for } x \leq 3 \end{cases}$ continuous at $x = 3$? Why or why not? 182) _____

A) Yes, $\lim_{x \rightarrow 3} f(x) = f(3)$

B) No, $\lim_{x \rightarrow 3} f(x)$ does not exist

Find the intervals on which the function is continuous.

183) $y = \frac{1}{x+5} - 5x$ 183) _____

A) discontinuous only when $x = -5$
C) continuous everywhere

B) discontinuous only when $x = 5$
D) discontinuous only when $x = -10$

184) $y = \frac{3}{(x+4)^2 + 8}$ 184) _____

A) discontinuous only when $x = 24$
C) discontinuous only when $x = -4$

B) continuous everywhere
D) discontinuous only when $x = -32$

185) $y = \frac{x+3}{x^2 - 7x + 12}$ 185) _____

A) discontinuous only when $x = 3$
C) discontinuous only when $x = -3$ or $x = 4$

B) discontinuous only when $x = 3$ or $x = 4$
D) discontinuous only when $x = -4$ or $x = 3$

186) $y = \frac{2}{x^2 - 16}$ 186) _____

A) discontinuous only when $x = -4$

D
)
d

B)
discontin
uous only
when $x =$
16
i
C)
discontin
uous only
when $x =$
-4 or $x = 4$
s

continuous only when $x = -16$ or $x = 16$

186) _____

$$187) y = \frac{2}{x^2 - 1}$$

187) _____

$$x + 1 \neq 0$$

- A) discontinuous only when $x = -1$
 C) discontinuous only when $x = -3$

- B) continuous everywhere
 D) discontinuous only when $x = -2$ or $x = -1$

$$188) y = \frac{\sin(3\theta)}{2\theta}$$

188) _____

- A) continuous everywhere

- B) discontinuous only when $\theta = \pi$

- C) discontinuous only when $\theta = 2$

- D) discontinuous only when $\theta = 0$

$$2 \cos \theta$$

$$189) y = \frac{\pi}{\theta - 2}$$

189) _____

- A) discontinuous only when $\theta = 2$

- B) continuous everywhere

- C) discontinuous only when $\theta = 9$

- D) discontinuous only when $\theta = -9$

$$190) y = \sqrt{2x + 2}$$

190) _____

- A) continuous on the interval $]1, \infty[$
 C) continuous on the interval $]-\infty, -1]$

- B) continuous on the interval $]-1, \infty[$
 D) continuous on the interval $]1, \infty[$

$$191) y = \sqrt[4]{9x - 9}$$

191) _____

- A) continuous on the interval $]1, \infty[$
 C) continuous on the interval $]1, \infty[$

- B) continuous on the interval $]-\infty, 1]$
 D) continuous on the interval $]-1, \infty[$

$$192) y = \sqrt{x^2 - 10}$$

192) _____

- A) continuous on the intervals $(-\infty, -\sqrt{10}]$ and $[\sqrt{10}, \infty)$
 B) continuous on the interval $[-\sqrt{10}, \sqrt{10}]$
 C) continuous on the interval $[\sqrt{10}, \infty)$
 D) continuous everywhere

Find the limit, if it exists.

$$193) \lim_{x \rightarrow -3} (x^2 - 16 + \sqrt[3]{x^2 - 36})$$

193) _____

- A) Does not exist

- B) 4

- C) -4

- D) -10

$$194) \lim_{x \rightarrow \infty} \left(\frac{11x - 1}{x} \right)^3$$

194) _____

- A) 1000

- B) 1331

- C) Does not exist

- D) ∞

Provide an appropriate response.

195) Is f continuous on $(-2, 4]$?

195) _____

$$f(x) = \begin{cases} x^3, & -2 < x \leq 0 \\ -2x, & 0 \leq x < 2 \\ 3, & 2 < x \leq 4 \\ 0, & x = 2 \end{cases}$$

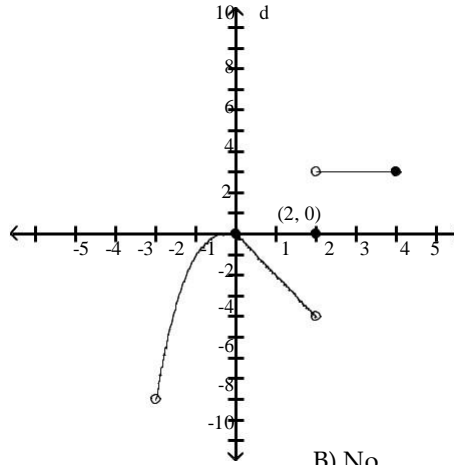

A) Yes

B) No

Find the limit, if it exists.

196) $\lim_{x \rightarrow -3} (x^2 - 16 + \frac{3}{x} \sqrt{2x - 36})$

196) _____

A) -4

B) Does not exist

C) 4

D) -10

197) $\lim_{x \rightarrow 4} x^2 \sqrt{4x + 4}$

197) _____

A) 36

B) 6

C) Does not exist

D) ± 6

198) $\lim_{x \rightarrow 1} \sqrt[4]{-4}$

198) _____

A) -1.7320508

B) 1.73205081

C) Does not exist

D) 0

199) $\lim_{x \rightarrow 8} x^2 \sqrt{9x - 8}$

199) _____

A) $\pm \sqrt{55}$

B) 27.5

C) $\sqrt{55}$

D) Does not exist

200) $\lim_{x \rightarrow -9^-} \sqrt{x^2 - 81}$

200) _____

A) 0

B) 4.5

C) $9\sqrt{3}$

D) Does not exist

201) $\lim_{x \rightarrow 7^+} \frac{-7\sqrt{(x-7)^3}}{x-7}$

201) _____

A) $-7\sqrt{7}$

B) 0

C) -7

D) Does not exist

202) $\lim_{t \rightarrow 1^+} \frac{\sqrt{(t+49)(t-1)^2}}{15t-15}$

202) _____

A) $\frac{1}{15}$

B) $\frac{\sqrt{50}}{15}$

C) 0

D) Does not exist

SHORT ANSWER. Write the word or phrase that best completes each statement or answers the question. Provide an appropriate response.

203) Use the Intermediate Value Theorem to prove that $2x^3 - 7x^2 - 9x + 4 = 0$ has a solution between 4 and 5. 203) _____

204) Use the Intermediate Value Theorem to prove that $3x^4 + 7x - 5 = 0$ has a solution between $\frac{2}{3}$ and -1. 204) _____

205) Use the Intermediate Value Theorem to prove that $x(x - 7)^2 = 7$ has a solution between 6 and 8. 205) _____

206) Use the Intermediate Value Theorem to prove that $6 \sin x = x$ has a solution between $\frac{\pi}{2}$ and π . 206) _____

MULTIPLE CHOICE. Choose the one alternative that best completes the statement or answers the question. Find numbers a and b, or k, so that f is continuous at every point.

207) _____ 207) _____

$$f(x) = \begin{cases} 14, & x < -2 \\ ax + b, & -2 \leq x \leq 5 \\ 35, & x > 5 \end{cases}$$

- A) $a = 14, b = 35$ B) $a = 3, b = 20$ C) $a = 3, b = 50$ D) Impossible

208) _____ 208) _____

$$f(x) = \begin{cases} x^2, & x < -1 \\ ax + b, & -1 \leq x \leq 2 \\ x + 2, & x > 2 \end{cases}$$

- A) $a = 1, b = -2$ B) $a = -1, b = 2$ C) $a = 1, b = 2$ D) Impossible

209) _____ 209) _____

$$f(x) = \begin{cases} 10x + 9, & \text{if } x < -1 \\ kx + 2, & \text{if } x \geq -1 \end{cases}$$

- A) $k = 2$ B) $k = 17$ C) $k = -2$ D) $k = 3$

210) _____ 210) _____

$$f(x) = \begin{cases} x^2, & \text{if } x \leq 8 \\ x + k, & \text{if } x > 8 \end{cases}$$

- A) $k = 72$ B) $k = -8$ C) $k = 56$ D) Impossible

211) _____ 211) _____

$$f(x) = \begin{cases} x^2, & \text{if } x \leq 7 \end{cases}$$

kx , if $x > 7$

.

{

A) $k = 7$

B) $k = \frac{1}{7}$

C) $k = 49$

D) Impossible

Solve the problem.

212) Select the correct statement for the definition of the limit: $\lim_{x \rightarrow x_0} f(x) = L$

212) _____

means that _____

- A) if given any number $\varepsilon > 0$, there exists a number $\delta > 0$, such that for all x , $0 < x - x_0 < \delta$ implies $|f(x) - L| < \varepsilon$.
- B) if given any number $\varepsilon > 0$, there exists a number $\delta > 0$, such that for all x , $0 < x - x_0 < \delta$ implies $|f(x) - L| < \delta$.
- C) if given a number $\varepsilon > 0$, there exists a number $\delta > 0$, such that for all x , $0 < x - x_0 < \delta$ implies $|f(x) - L| < \varepsilon$.
- D) if given any number $\varepsilon > 0$, there exists a number $\delta > 0$, such that for all x , $0 < x - x_0 < \varepsilon$ implies $|f(x) - L| < \delta$.

213) Identify the incorrect statements about limits.

213) _____

I. The number L is the limit of $f(x)$ as x approaches x_0 if $f(x)$ gets closer to L as x approaches x_0 .

II. The number L is the limit of $f(x)$ as x approaches x_0 if, for any $\varepsilon > 0$, there corresponds a $\delta > 0$ such that $f(x) - L < \varepsilon$ whenever $0 < x - x_0 < \delta$.

III. The number L is the limit of $f(x)$ as x approaches x_0 if, given any $\varepsilon > 0$, there exists a value of x for which $|f(x) - L| < \varepsilon$.

- A) I and II B) II and III C) I and III D) I, II, and III

Use the graph to find a $\delta > 0$ such that for all x , $0 < |x - x_0| < \delta \Rightarrow |f(x) - L| < \varepsilon$.

214)

214) _____

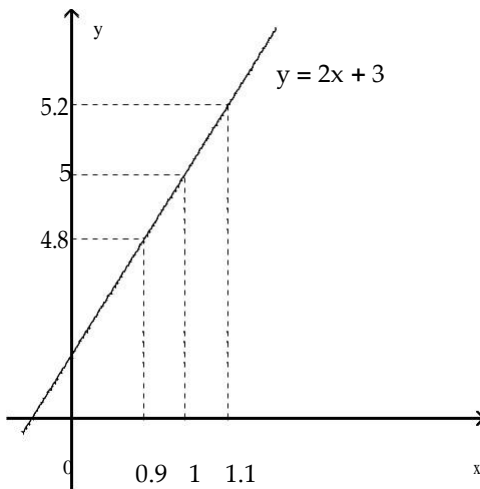

$f(x) = 2x + 3$
 $x_0 = 1$
 $L = 5$
 $\varepsilon = 0.2$

NOT TO SCALE

- A) 0.4 B) 4 C) 0.2 D) 0.1

215)

215) _____

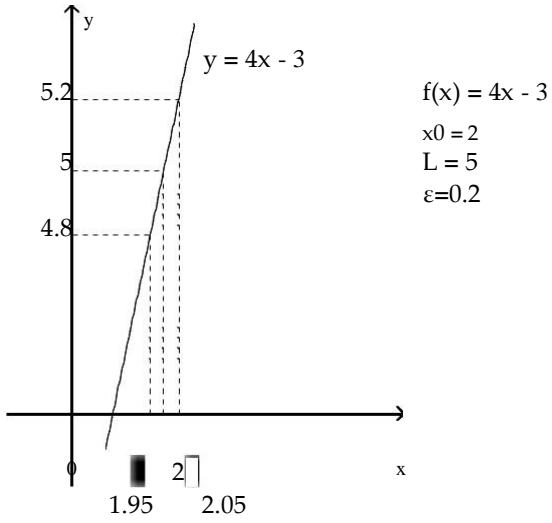

NOT TO SCALE

A) 0.1

B) 0.05

C) 0.5

D) 3

216)

216) _____

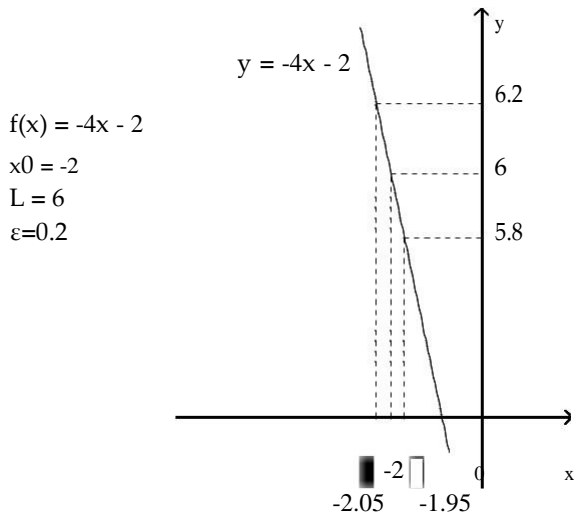

NOT TO SCALE

A) 12

B) -0.05

C) 0.5

D) 0.05

217)

$f(x) = -2x + 3$
 $x_0 = -2$
 $L = 7$
 $\varepsilon = 0.2$

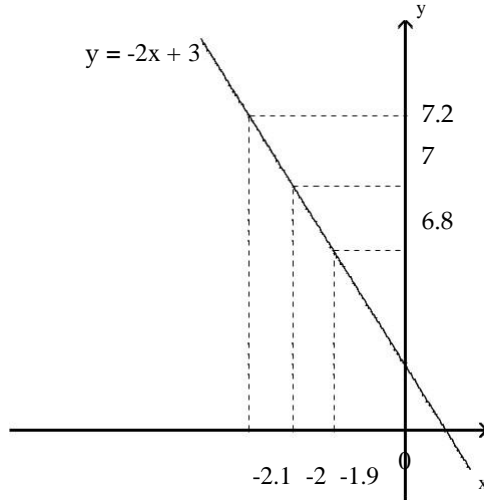

NOT TO SCALE

A) 9

B) 0.2

C) 0.1

D) -0.1

217) _____

218)

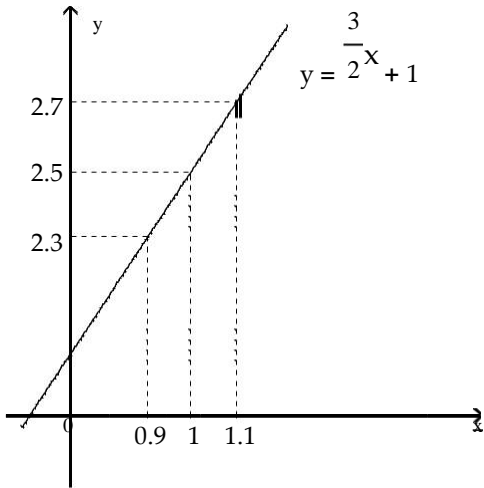

NOT TO SCALE

$f(x) = \frac{3}{2^x} + 1$
 $x_0 = 1$
 $L = 2.5$
 $\varepsilon = 0.2$

A) -0.2

B) 0.2

C) 1.5

D) 0.1

218) _____

219)

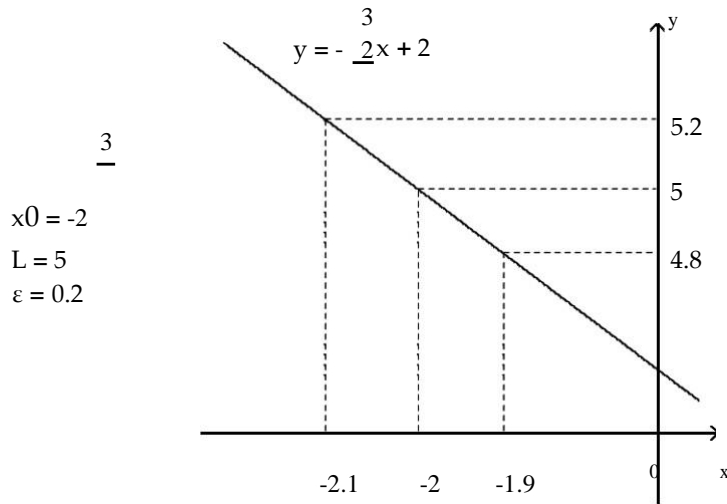

NOT TO SCALE

A) 0.1

B) 7

C) 0.2

D) -0.2

220)

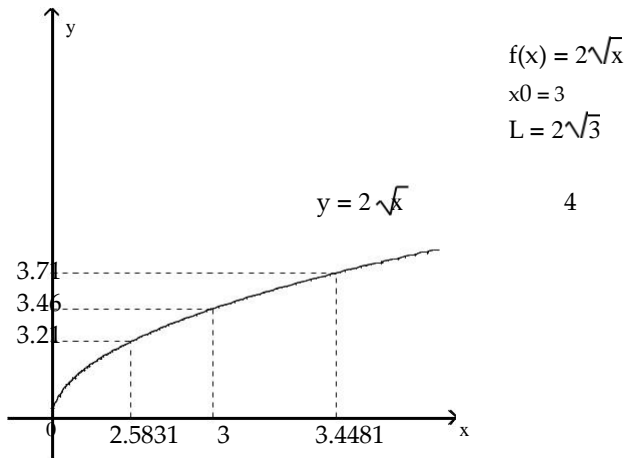

NOT TO SCALE

A) 0.865

B) 0.4169

C) 0.46

D) 0.4481

219) _____

220) _____

221)

221) _____

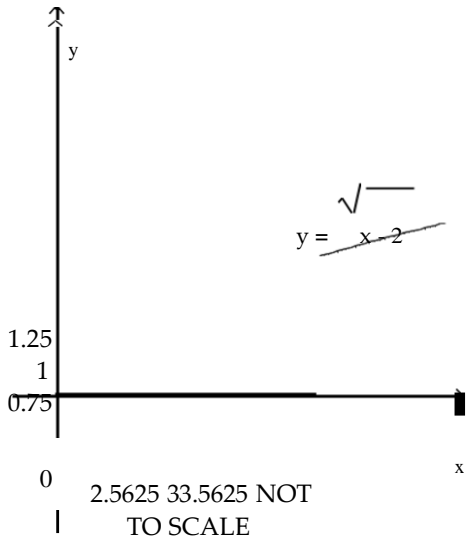

A) 0.4375

B) 1

C) 0.5625

D) 2

222)

222) _____

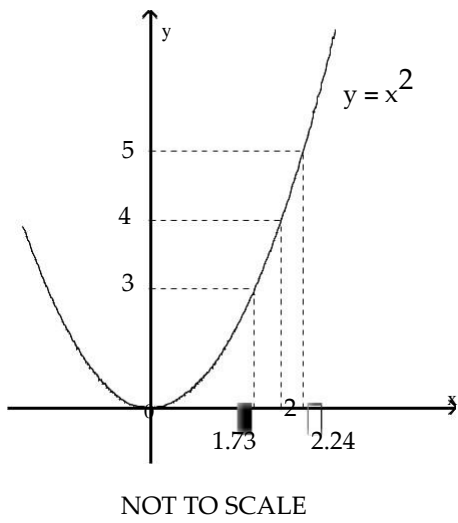

A) 0.51

B) 0.27

C) 2

D) 0.24

223)

223) _____

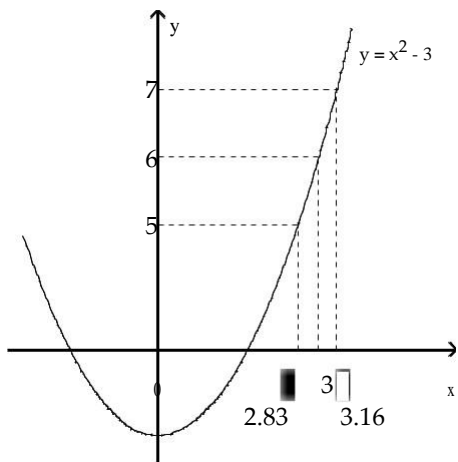

$f(x) = x^2 - 3$
 $x_0 = 3$
 $L = 6$
 $\epsilon = 1$

NOT TO SCALE

- A) 0.33 B) 0.17 C) 0.16 D) 3

A function $f(x)$, a point x_0 , the limit of $f(x)$ as x approaches x_0 , and a positive number ϵ is given. Find a number $\delta > 0$ such that for all x ,

$$0 < x - x_0 < \delta \Rightarrow f(x) - L < \epsilon.$$

- 224) $f(x) = 9x + 3$, $L = 21$, $x_0 = 2$, and $\epsilon = 0.01$ 224) _____
 A) 0.002222 B) 0.001111 C) 0.005 D) 0.005556

- 225) $f(x) = 6x - 9$, $L = -3$, $x_0 = 1$, and $\epsilon = 0.01$ 225) _____
 A) 0.01 B) 0.001667 C) 0.000833 D) 0.003333

- 226) $f(x) = -8x + 4$, $L = -4$, $x_0 = 1$, and $\epsilon = 0.01$ 226) _____
 A) 0.0025 B) -0.01 C) 0.005 D) 0.00125

- 227) $f(x) = -2x - 7$, $L = -11$, $x_0 = 2$, and $\epsilon = 0.01$ 227) _____
 A) 0.005 B) -0.005 C) 0.0025 D) 0.01

- 228) $f(x) = 3x^2$, $L = 108$, $x_0 = 6$, and $\epsilon = 0.5$ 228) _____
 A) 6.01387 B) 5.98609 C) 0.01391 D) 0.01387

SHORT ANSWER. Write the word or phrase that best completes each statement or answers the question.

Prove the limit statement

229) $\lim_{x \rightarrow 1} (5x - 1) = 4$ 229) $x \rightarrow 1$ _____

230) $\lim_{x \rightarrow 7} \frac{x^2 - 49}{x - 7} = 14$ 230) _____

231) $\lim_{x \rightarrow 9} \frac{2x^2 - 15x - 27}{x - 9} = 21$ 231) _____

$$232) \lim_{x \rightarrow 7} \frac{1}{x-7} = 1$$

$$x \rightarrow 7 \quad x - 7$$

232) _____

Answer Key

Testname: UNTITLED2

- 1) B
- 2) A
- 3) A
- 4) C
- 5) B
- 6) B
- 7) A
- 8) B
- 9) D
- 10) D
- 11) A
- 12) B
- 13) A
- 14) A
- 15) B
- 16) A
- 17) D
- 18) B
- 19) D
- 20) C
- 21) C
- 22) C
- 23) B
- 24) C
- 25) C
- 26) A
- 27) C
- 28) D
- 29) B
- 30) B
- 31) D
- 32) A
- 33) D
- 34) A
- 35) C
- 36) C
- 37) B
- 38) A
- 39) D
- 40) C
- 41) D

42) Answers may vary. One possibility: $\lim_{x \rightarrow 0} \frac{x^2}{6 - 2 \cos(x)}$

$\lim_{x \rightarrow 0} \frac{x^2}{6 - 2 \cos(x)} = \lim_{x \rightarrow 0} 1 = 1$. According to the squeeze theorem, the function

$\frac{x \sin(x)}{6 - 2 \cos(x)}$, which is squeezed between $\frac{x^2}{6}$ and 1, must also approach 1 as x approaches 0. Thus,

$$\lim_{x \rightarrow 0} \frac{x \sin(x)}{6 - 2 \cos(x)} = 1.$$

$$x \rightarrow 0 \quad 2 - 2 \cos(x)$$

Answer Key

Testname: UNTITLED2

Answer Key

Testname: UNTITLED2

- 44) D
- 45) D
- 46) B
- 47) B
- 48) C
- 49) A
- 50) C
- 51) A
- 52) A
- 53) A
- 54) A
- 55) D
- 56) A
- 57) A
- 58) B
- 59) C
- 60) D
- 61) D
- 62) A
- 63) B
- 64) C
- 65) A
- 66) C
- 67) A
- 68) D
- 69) D
- 70) A
- 71) D
- 72) C
- 73) C
- 74) A
- 75) A
- 76) A
- 77) B
- 78) A
- 79) A
- 80) C
- 81) C
- 82) B
- 83) A
- 84) A
- 85) A
- 86) C
- 87) B
- 88) D
- 89) B
- 90) A
- 91) C
- 92) A
- 93) D

Answer Key

Testname: UNTITLED2

- 94) A
- 95) A
- 96) A
- 97) C
- 98) D
- 99) C
- 100) D
- 101) D
- 102) B
- 103) A
- 104) D
- 105) D
- 106) D
- 107) C
- 108) C
- 109) D
- 110) B
- 111) A
- 112) A
- 113) D
- 114) D
- 115) C
- 116) C
- 117) C
- 118) C
- 119) B
- 120) C
- 121) D
- 122) A
- 123) D
- 124) A
- 125) C
- 126) B
- 127) B
- 128) D
- 129) C
- 130) D
- 131) D
- 132) C
- 133) B
- 134) A
- 135) C
- 136) C
- 137) D
- 138) B
- 139) C
- 140) A
- 141) D
- 142) C
- 143) B

Answer Key

Testname: UNTITLED2

144) C

145) C

146) D

147) C

148) B

149) A

150) D

151) A

152) C

153) D

154) B

155) Answers may vary. One possible answer:

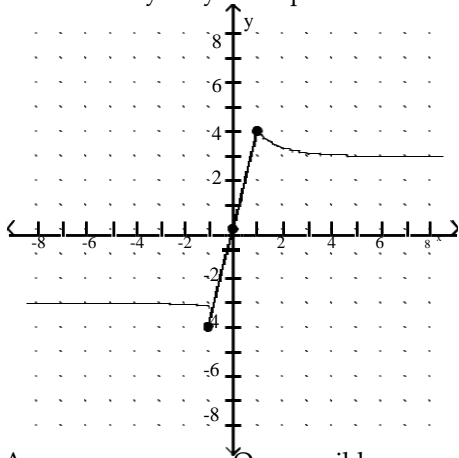

156) Answers may vary. One possible answer:

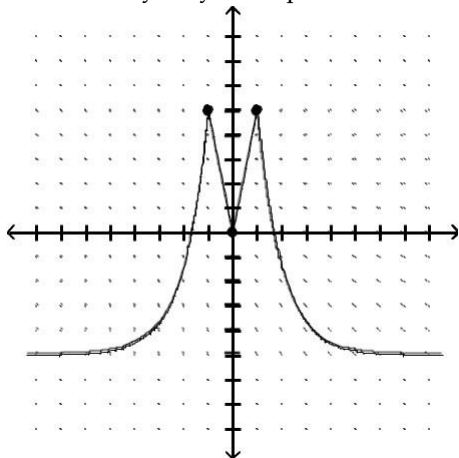

Answer Key

Testname: UNTITLED2

157) Answers may vary. One possible answer:

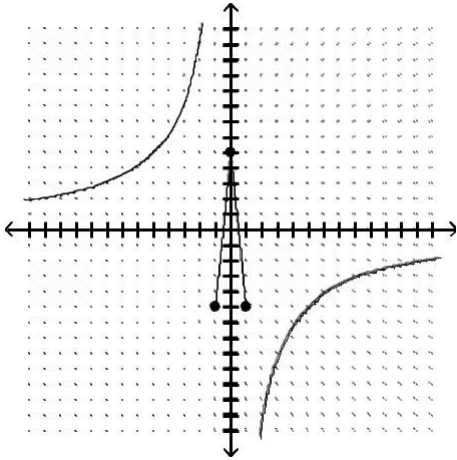

158) Answers may vary. One possible answer:

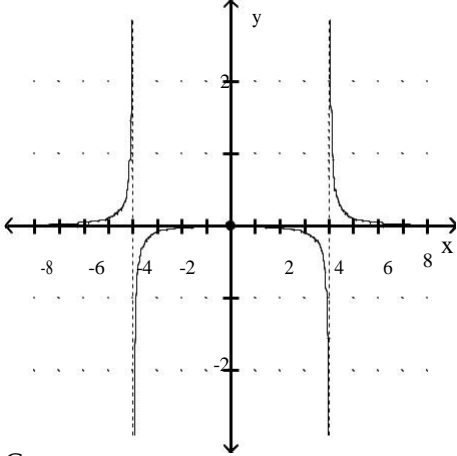

- 159) C
- 160) C
- 161) A
- 162) A
- 163) B
- 164) B
- 165) D
- 166) B
- 167) C
- 168) B
- 169) D
- 170) B
- 171) C
- 172) B
- 173) C
- 174) D
- 175) B
- 176) B
- 177) A
- 178) A

179) B

Answer Key

Testname: UNTITLED2

- 180) A
- 181) A
- 182) B
- 183) A
- 184) B
- 185) B
- 186) C
- 187) B
- 188) D
- 189) D
- 190) B
- 191) C
- 192) A
- 193) D
- 194) B
- 195) B
- 196) D
- 197) B
- 198) C
- 199) C
- 200) A
- 201) B
- 202) B

203) Let $f(x) = 2x^3 - 7x^2 - 9x + 4$ and let $y_0 = 0$. $f(4) = -16$ and $f(5) = 34$. Since f is continuous on $[4, 5]$ and since $y_0 = 0$ is between $f(4)$ and $f(5)$, by the Intermediate Value Theorem, there exists a c in the interval $(4, 5)$ with the property that $f(c) = 0$. Such a c is a solution to the equation $2x^3 - 7x^2 - 9x + 4 = 0$.

204) Let $f(x) = 3x^4 - 2x^3 + 7x - 5$ and let $y_0 = 0$. $f(-2) = 45$ and $f(-1) = -7$. Since f is continuous on $[-2, -1]$ and since $y_0 = 0$ is between $f(-2)$ and $f(-1)$, by the Intermediate Value Theorem, there exists a c in the interval $(-2, -1)$ with the property that $f(c) = 0$. Such a c is a solution to the equation $3x^4 - 2x^3 + 7x - 5 = 0$.

205) Let $f(x) = x(x - 7)^2$ and let $y_0 = 7$. $f(6) = 6$ and $f(8) = 8$. Since f is continuous on $[6, 8]$ and since $y_0 = 7$ is between $f(6)$ and $f(8)$, by the Intermediate Value Theorem, there exists a c in the interval $(6, 8)$ with the property that $f(c) = 7$. Such a c is a solution to the equation $x(x - 7)^2 = 7$.

206) Let $f(x) = \frac{\sin x}{x}$ and let $y = \frac{1}{6}$. $f\left(\frac{\pi}{2}\right) \approx 0.6366$ and $f(\pi) = 0$. Since f is continuous on $\left[\frac{\pi}{2}, \pi\right]$ and since $y = \frac{1}{6}$ is between

$f\left(\frac{\pi}{2}\right)$ and $f(\pi)$, by the Intermediate Value Theorem, there exists a c in the interval $\left[\frac{\pi}{2}, \pi\right]$ with the property that

$f(c) = \frac{1}{6}$. Such a c is a solution to the equation $6 \sin x = x$.

- 207) B
- 208) C
- 209) D
- 210) C
- 211) A
- 212) B
- 213) C
- 214) D
- 215) B

Answer Key

Testname: UNTITLED2

- 216) D
- 217) C
- 218) D
- 219) A
- 220) B
- 221) A
- 222) D
- 223) C
- 224) B
- 225) B
- 226) D
- 227) A
- 228) D

229)

Let $\epsilon > 0$ be given. Choose $\delta = \epsilon/5$. Then $0 < |x - 1| < \delta$ implies that

$$\begin{aligned} \left| \frac{5x - 1}{5} - 1 \right| &= \left| \frac{5(x - 1)}{5} \right| \\ &= |x - 1| < 5\delta = \epsilon \end{aligned}$$

Thus, $0 < |x - 1| < \delta$ implies that $\left| \frac{5x - 1}{5} - 1 \right| < \epsilon$

230) Let $\epsilon > 0$ be given. Choose $\delta = \epsilon$. Then $0 < |x - 7| < \delta$ implies that

$$\begin{aligned} \left| \frac{x^2 - 49}{x - 7} - 14 \right| &= \left| \frac{(x - 7)(x + 7)}{x - 7} - 14 \right| \\ &= |x + 7 - 14| \quad \text{for } x \neq 7 \\ &= |x - 7| < \delta = \epsilon \end{aligned}$$

Thus, $0 < |x - 7| < \delta$ implies that $\left| \frac{x^2 - 49}{x - 7} - 14 \right| < \epsilon$

231) Let $\epsilon > 0$ be given. Choose $\delta = \epsilon/2$. Then $0 < |x - 9| < \delta$ implies that

$$\begin{aligned} \left| \frac{2x^2 - 15x - 27}{x - 9} - 21 \right| &= \left| \frac{(x - 9)(2x + 3)}{x - 9} - 21 \right| \\ &= |2x + 3 - 21| \quad \text{for } x \neq 9 \\ &= |2x - 18| \\ &= |2(x - 9)| \\ &= 2|x - 9| < 2\delta = \epsilon \end{aligned}$$

Thus, $0 < |x - 9| < \delta$ implies that $\left| \frac{2x^2 - 15x - 27}{x - 9} - 21 \right| < \epsilon$

232) Let $\epsilon > 0$ be given. Choose $\delta = \min\{7/2, 49\epsilon/2\}$. Then $0 < |x - 7| < \delta$ implies that $1 - 1 =$

$$\begin{aligned} \left| \frac{1}{7 - x} - \frac{1}{7} \right| &= \left| \frac{1}{7x} \right| \\ &= \frac{1}{|x|} \cdot \frac{1}{7} \cdot |x - 7| \\ &= \frac{1}{7/2} \cdot \frac{1}{7} \cdot \frac{49}{2} \epsilon = \epsilon \end{aligned}$$

Thus, $0 < |x - 7| < \delta$ implies that $\left| \frac{1}{x} - \frac{1}{7} \right| < \epsilon$

