

Test Bank for Calculus for Business Economics Life Sciences and Social Sciences 13th Edition by Barnett Ziegler and Byleen ISBN 0321925130 9780321925138

**Full link download
Solution Manual:**

<https://testbankpack.com/p/solution-manual-for-calculus-for-business-economics-life-sciences-and-social-sciences-13th-edition-by-barnett-ziegler-and-byleen-isbn-0321925130-9780321925138/>

Test Bank:

<https://testbankpack.com/p/test-bank-for-calculus-for-business-economics-life-sciences-and-social-sciences-13th-edition-by-barnett-ziegler-and-byleen-isbn-0321925130-9780321925138/>

MULTIPLE CHOICE. Choose the one alternative that best completes the statement or answers the question.

Provide an appropriate response.

1) Given that $f(x) = \frac{x}{7-x}$, find $f\left(\frac{4}{5}\right)$. Express the answer as a simplified fraction.

A) $\frac{39}{4}$

B) $\frac{-39}{4}$

C) $-\frac{39}{4}$

D) $-\frac{39}{4}$

Answer: C

The graph of a function f is given. Use the graph to answer the question.

2) Use the graph of f given below to find $f(-10)$.

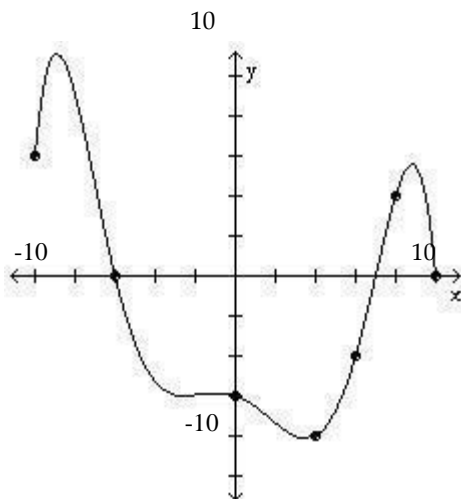

A) -10

B) 0

C) 6

D) 16

Answer: C

Use the graph to evaluate the indicated limit and function value or state that it does not exist.

3) Find $\lim_{x \rightarrow 0} f(x)$ and $f(0)$.

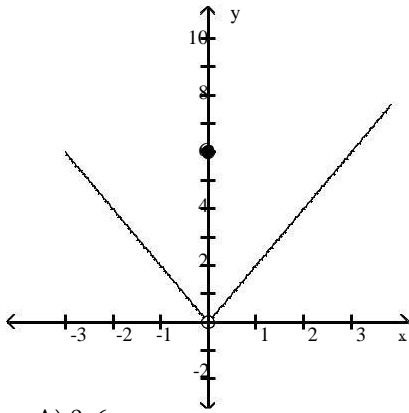

- A) 0; 6
- B) 0; does not exist
- C) Does not exist; 6
- D) 6; 0

Answer: A

4) Find $\lim_{x \rightarrow 0^-} f(x)$ and $\lim_{x \rightarrow 0^+} f(x)$.

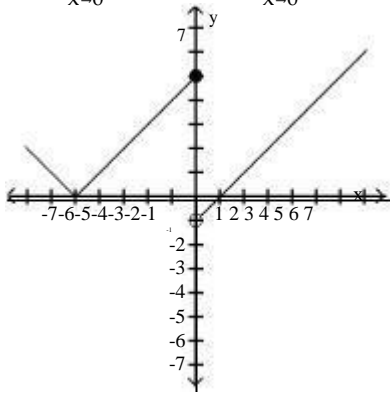

6
5
4
3
2
1

- A) 5; -1
- B) -1; 5
- C) Does not exist; does not exist
- D) 5; Does not exist

Answer: A

Find the limit, if it exists.

5) Find: $\lim_{x \rightarrow -1} \frac{6x+5}{5x-6}$

- A) 1
- B) $\frac{-1}{11}$
- C) -11
- D) $-\frac{1}{11}$

Answer: B

6) Given $\lim_{x \rightarrow 4} f(x) = -2$ and $\lim_{x \rightarrow 4} g(x) = 5$, find $\lim_{x \rightarrow 4} \frac{[g(x) - f(x)]}{-4 f(x)}$.

A) $\frac{3}{8}$

B) $8\frac{7}{8}$

C) $8\frac{7}{8}$

D) $8\frac{3}{8}$

Answer: B

7) Find: $\lim_{x \rightarrow -4} \frac{x^2 - 16}{4x - 4x}$

A) 16

B) 8

C) -8

D) -24

Answer: C

$x - 5$

8) Find: $\lim_{x \rightarrow 5} \frac{x-5}{|x-5|}$

A) -1

B) 1

C) 0

D) Does not exist

Answer: D

9) Find: $\lim_{x \rightarrow 3} \left(\frac{x^2 - 9}{x - 3} + \sqrt[3]{x^2 + 7} \right)$

A) 10

B) 3

C) 2

D) Does not exist

Answer: A

10) Find: $\lim_{x \rightarrow 3} \frac{x^2 - 3}{x - 3}$

A) $3\frac{1}{2}$

B) $-3\frac{1}{2}$

C) 0

D) Does not exist

Answer: D

11) Given $\lim_{x \rightarrow 5} f(x) = 4$ and $\lim_{x \rightarrow 5} g(x) = -5$, find $\lim_{x \rightarrow 5} \frac{2f(x)+3g(x)}{3f(x)}$.

A) -12^7

B) $^7 12$

C) -15^7

D) $^7 15$

Answer: A

12) Evaluate the following limit

$$\lim_{x \rightarrow 2^-} \frac{1}{x-2}$$

A) ∞

B) 2

C) $-\infty$

D) Does not exist

Answer: D

13) Let $f(x) = \frac{x^2 - 3x - 10}{x + 2}$. Find $\lim_{x \rightarrow -2} f(x)$.

A) -2

B) 5

C) -7

D) Does not exist

Answer: C

14) Let $f(x) = \begin{cases} \frac{x^2 - 16}{x + 4} & \text{if } x > 0 \\ \frac{x^2 - 16}{x - 4} & \text{if } x < 0 \end{cases}$

Find $\lim_{x \rightarrow 0^-} f(x)$.

A) -4

B) ∞

C) 4

D) Does not exist

Answer: C

15) Let $f(x) = \begin{cases} \frac{x^2 - 16}{x + 4} & \text{if } x > 0 \\ 2 & \\ \frac{x^2 - 16}{x - 4} & \text{if } x < 0 \end{cases}$

Find $\lim_{x \rightarrow 0^+} f(x)$

- A) 0
- B) -4
- C) 4
- D) Does not exist

Answer: B

16) Let $f(x) = \begin{cases} \frac{x^2 - 16}{x + 4} & \text{if } x > 0 \\ 2 & \\ -\frac{x^2 - 16}{x - 4} & \text{if } x < 0 \end{cases}$

Find $\lim_{x \rightarrow 0} f(x)$.

- A) $-\infty$
- B) -4
- C) 0
- D) Does not exist

Answer: D

17) Evaluate the following limit.

$$\lim_{x \rightarrow 2^+} \frac{1}{x - 2}$$

- A) 2
- B) $-\infty$
- C) ∞
- D) Does not exist

Answer: D

Sketch a possible graph of a function that satisfies the given conditions.

18) $f(1) = 4$; $\lim_{x \rightarrow 1^-} f(x) = 4$; $\lim_{x \rightarrow 1^+} f(x) = 3$

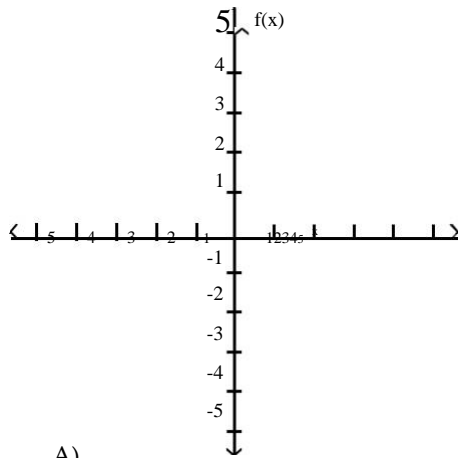

A)

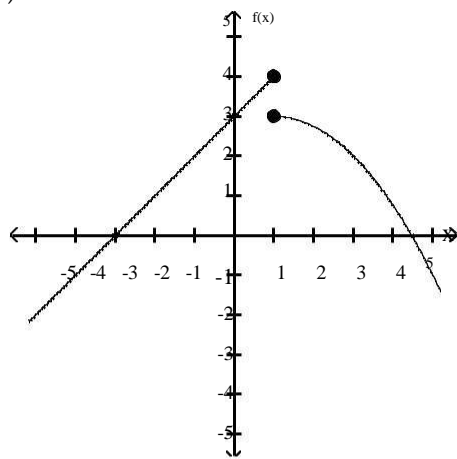

B)

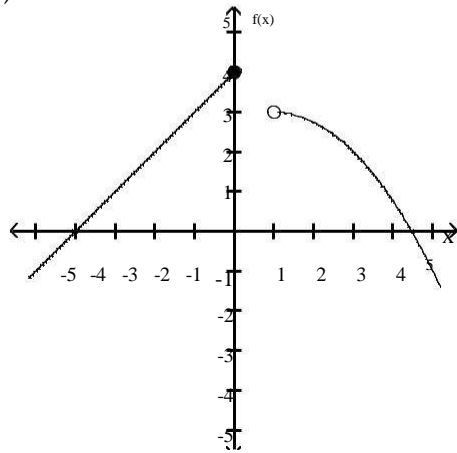

C)

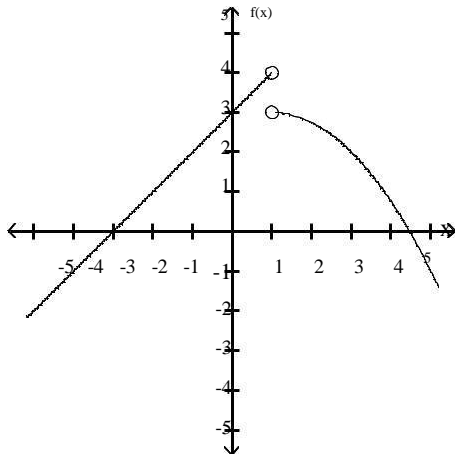

D)

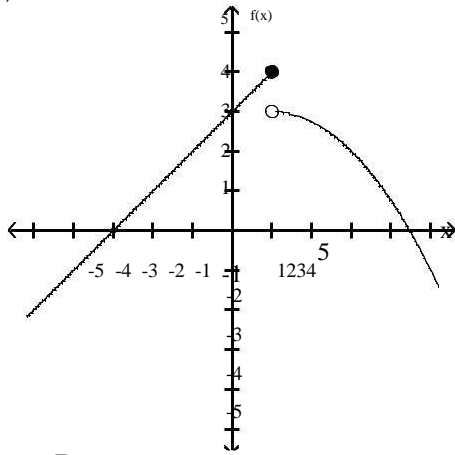

Answer: D

$$19) f(0) = 6; \lim_{x \rightarrow 0^-} f(x) = 0; \quad \lim_{x \rightarrow 0^+} f(x) = 0$$

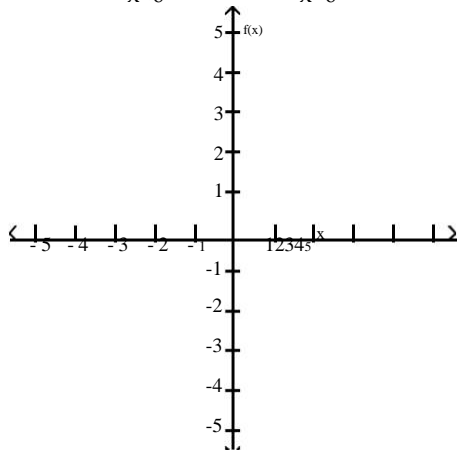

A)

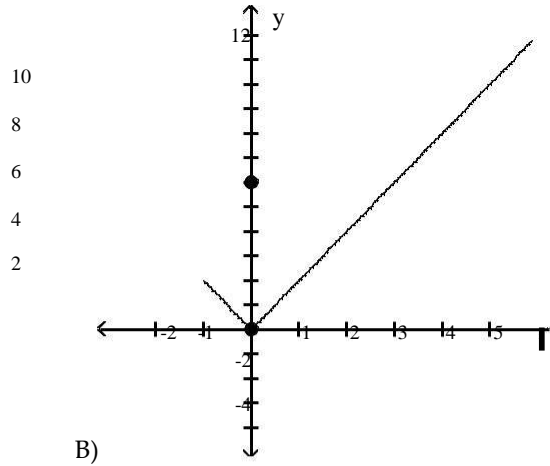

B)

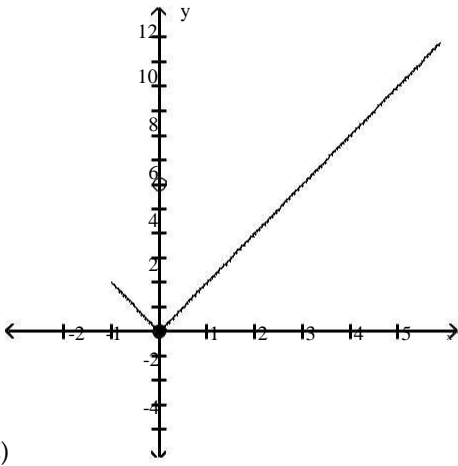

C)

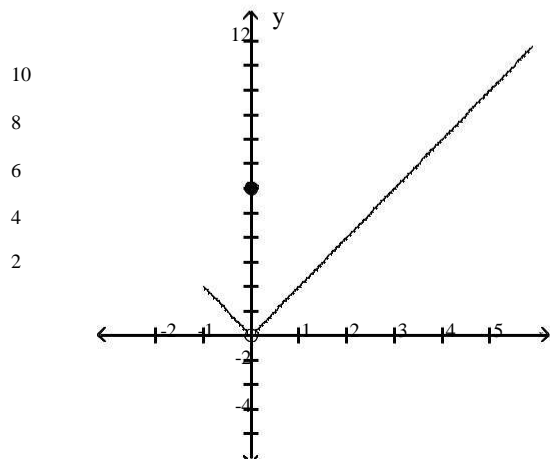

D)

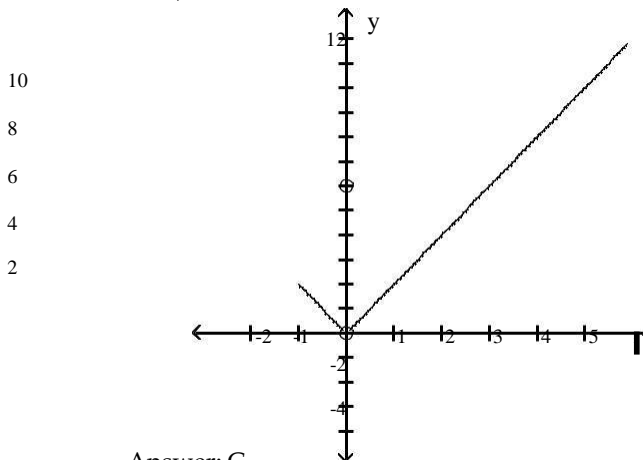

Answer: C

Find the limit, if it exists.

20) Find: $\lim_{h \rightarrow 0} \frac{f(7+h) - f(7)}{h}$ for $f(x) = -x + 1$.

- A) 1
- B) -1
- C) 0
- D) Does not exist

Answer: B

Solve the problem.

21) A company training program determines that, on average, a new employee can do $P(x)$ pieces of work per day after s days of on-the-job training, where $P(x) = \frac{90 + 60x}{x + 5}$. Find $\lim_{x \rightarrow 5} P(x)$.

- A) 105
- B) 30
- C) 42
- D) Does not exist

Answer: B

22) The cost of manufacturing a particular videotape is $C(x) = 9000 + 9x$, where x is the number of tapes produced.

The average cost per tape, denoted by $\bar{C}(x)$, is found by dividing $C(x)$ by x . Find

$$\lim_{x \rightarrow 9000} \bar{C}(x)$$

- A) 10
- B) 14
- C) 6
- D) Does not exist

Answer: A

Use the given graph to find the indicated limit.

23)

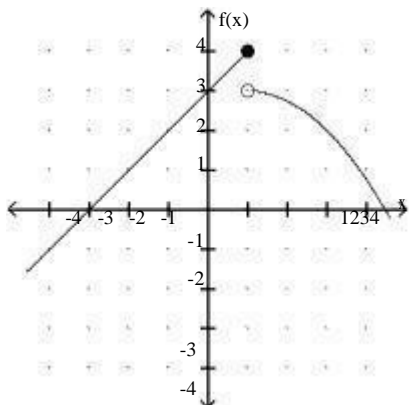

Find $\lim_{x \rightarrow -\infty} f(x)$.

$x \rightarrow -\infty$

A) ∞

B) 4

C) $-\infty$

D) 3

Answer: C

24)

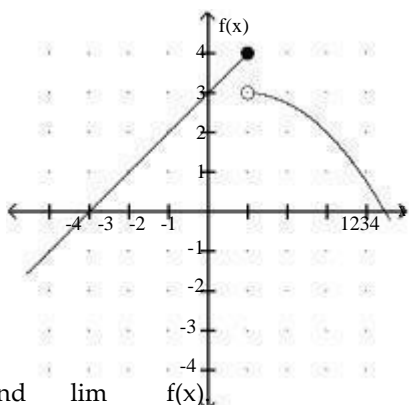

Find $\lim_{x \rightarrow -\infty} f(x)$.

A) ∞

B) $-\infty$

C) 4

D) 3

Answer: B

25)

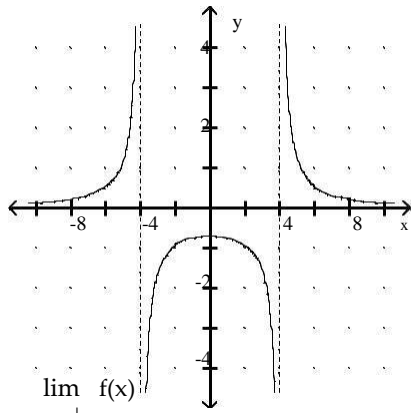

$$\lim_{x \rightarrow 4^+} f(x)$$

- A) ∞
- B) $-\infty$
- C) 4
- D) 0

Answer: A

26)

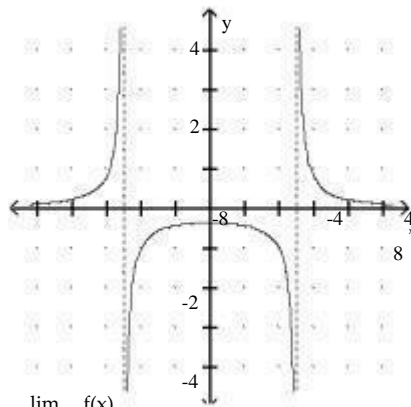

$$\lim_{x \rightarrow 5^-} f(x)$$

- A) 5
- B) ∞
- C) $-\infty$
- D) 0

Answer: C

Find the limit.

27) Determine the limit.

$$\lim_{x \rightarrow -10} f(x), \text{ where } f(x) = \frac{1}{x+10}$$

- A) $-\infty$
- B) 0
- C) -1
- D) ∞

Answer: A

28) Determine the limit.

$$\lim_{x \rightarrow 5^+} f(x), \text{ where } f(x) = \frac{x-2}{x-5}$$

- A) -2
- B) $-\infty$
- C) 5
- D) ∞

Answer: D

Provide an appropriate response.

29) If the limit at infinity exists, find the limit.

$$\lim_{x \rightarrow \infty} \frac{5x^2 + 7x - 9}{-6x^2 + 2}$$

- A) $-\frac{5}{6}$
- B) $-\frac{9}{2}$
- C) ∞
- D) 0

Answer: A

30) If the limit at infinity exists, find the limit.

$$\lim_{x \rightarrow \infty} \frac{3x^3 + 5x}{4x^4 + 10x^3 + 2}$$

- A) 0
- B) $\frac{3}{4}$
- C) ∞
- D) 1

Answer: A

Use $-\infty$ or ∞ where appropriate to describe the behavior at each zero of the denominator and identify all vertical asymptotes.

31) $g(x) = \frac{x}{6-x}$

- A) $\lim_{x \rightarrow 6^-} f(x) = -\infty$; $\lim_{x \rightarrow 6^+} f(x) = \infty$; $x = 6$ is a vertical asymptote
- B) $\lim_{x \rightarrow 6^-} f(x) = -\infty$; $\lim_{x \rightarrow 6^+} f(x) = -\infty$; $x = 6$ is a vertical asymptote
- C) $\lim_{x \rightarrow 6^-} f(x) = \infty$; $\lim_{x \rightarrow 6^+} f(x) = -\infty$; $x = 6$ is a vertical asymptote
- D) $\lim_{x \rightarrow 6^-} f(x) = \infty$; $\lim_{x \rightarrow 6^+} f(x) = -\infty$; $x = 0$ is a vertical asymptote

32) $f(x) = \frac{x^2 - 16}{x + 16}$

- A) $\lim_{x \rightarrow 4^-} f(x) = \infty$; $\lim_{x \rightarrow 4^+} f(x) = -\infty$; $x = 4$ is a vertical asymptote
- B) No zeros of denominator; no vertical asymptotes
- C) $\lim_{x \rightarrow -4^-} f(x) = \infty$; $\lim_{x \rightarrow -4^+} f(x) = -\infty$; $x = -4$ is a vertical asymptote
- D) $\lim_{x \rightarrow -4^-} f(x) = \infty$; $\lim_{x \rightarrow -4^+} f(x) = \infty$; $x = 0$ is a vertical asymptote

Answer: B

Describe the end behavior of the function.

33) $f(x) = 5x^4 + 5x + 11$

- A) $\lim_{x \rightarrow \infty} f(x) = -\infty$; $\lim_{x \rightarrow -\infty} f(x) = \infty$
- B) $\lim_{x \rightarrow \infty} f(x) = -\infty$; $\lim_{x \rightarrow -\infty} f(x) = -\infty$
- C) $\lim_{x \rightarrow \infty} f(x) = \infty$; $\lim_{x \rightarrow -\infty} f(x) = -\infty$
- D) $\lim_{x \rightarrow \infty} f(x) = \infty$; $\lim_{x \rightarrow -\infty} f(x) = \infty$

Answer: D

Provide an appropriate response.

34) Find the vertical asymptote(s) of the graph of the given function.

$f(x) = \frac{3x-9}{x^2-9}$

- A) $x = -6$
- B) $y = -3$
- C) $x = -8$
- D) $y = 8$

Answer: A

35) Find the vertical asymptote(s) of the graph of the given function.

$$f(x) = \frac{x^2 - 100}{(x - 9)(x + 3)}$$

- A) $x = 10, x = -10$
- B) $x = 9, x = -3$
- C) $y = 9, y = -3$
- D) $x = -9$

Answer: B

36) Find the horizontal asymptote, if any, of the given function. $f(x)$

$$f(x) = \frac{(x - 3)(x + 4)}{x^2 - 4}$$

- A) $y = 1$
- B) $x = 2, x = -2$
- C) $y = 3, y = -4$
- D) None

Answer: A

37) Find the horizontal asymptote, if any, of the given function.

$$f(x) = \frac{2x^3 - 3x - 2}{9x^3 - 5x + 3}$$

- A) $y = 5$
- B) $y = 9$
- C) $y = 0$
- D) None

Answer: B

Solve the problem.

38) Suppose that the value V of a certain product decreases, or depreciates, with time t , in months,

$$\text{where } V(t) = 37 - \frac{16t^2}{(t + 2)^2}$$

Find $\lim_{t \rightarrow \infty} V(t)$.

- A) 16
- B) 21
- C) 37
- D) 33

Answer: B

39) Suppose that the value V of a certain product decreases, or depreciates, with time t , in months, where

$$V(t) = 100 - \frac{40t^2}{(t + 2)^2}$$

Find $\lim_{t \rightarrow \infty} V(t)$.

- A) 80
- B) 40
- C) 100
- D) 60

Answer: D

40) Suppose that the cost C of removing $p\%$ of the pollutants from a chemical dumping site is given by $C(p) = \frac{\$40,000}{100 - p}$.

Can a company afford to remove 100% of the pollutants? Explain.

- A) Yes, the cost of removing $p\%$ of the pollutants is \$40,000, which is certainly affordable.
- B) No, the cost of removing $p\%$ of the pollutants is \$400, which is a prohibitive amount of money.
- C) Yes, the cost of removing $p\%$ of the pollutants is \$400, which is certainly affordable.
- D) No, the cost of removing $p\%$ of the pollutants increases without bound as p approaches 100.

Answer: D

Sketch a possible graph of a function that satisfies the given conditions.

41) $f(0) = 4$ and $\lim_{x \rightarrow 0} f(x) = 4$

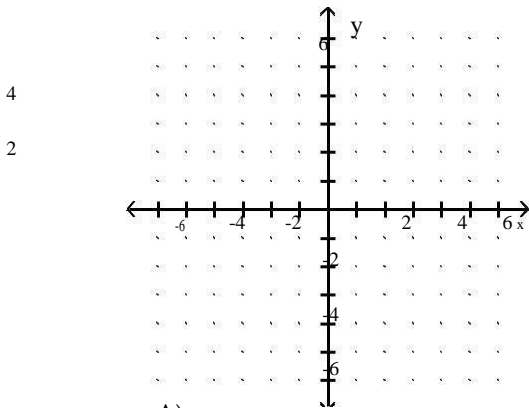

A)

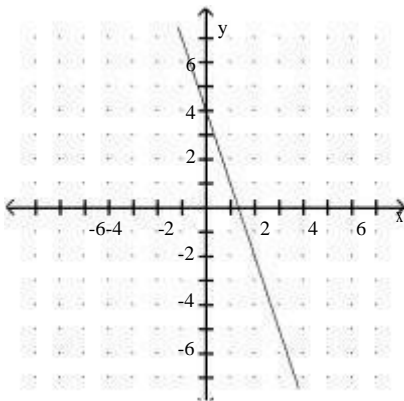

B)

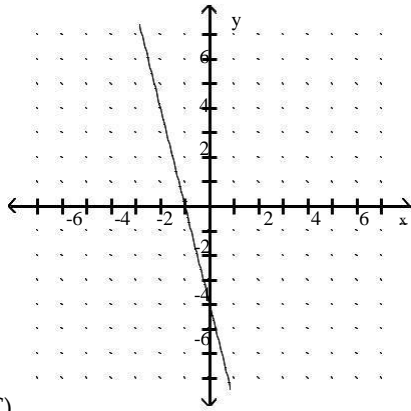

C)

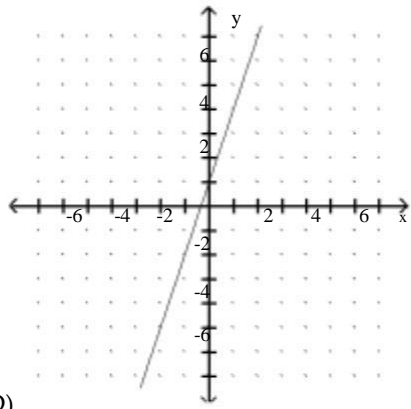

D)

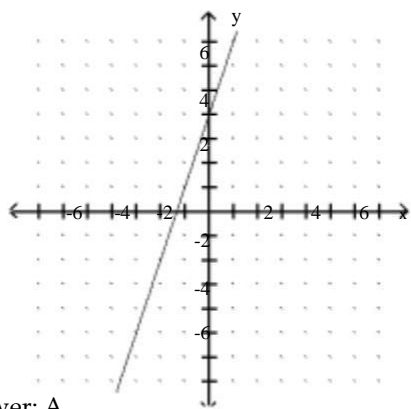

Answer: A

42) $f(-1) = -7$; $\lim_{x \rightarrow (-1)^-} f(x) = -2$; $\lim_{x \rightarrow (-1)^+} f(x) = -7$

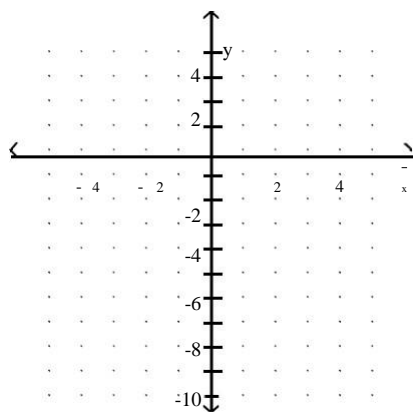

A)

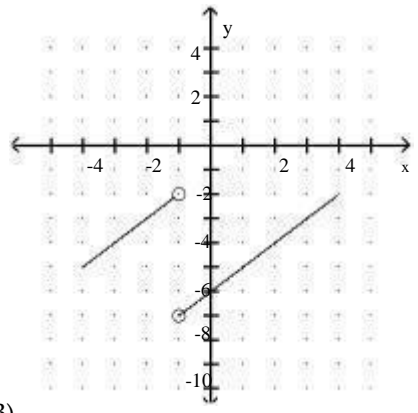

B)

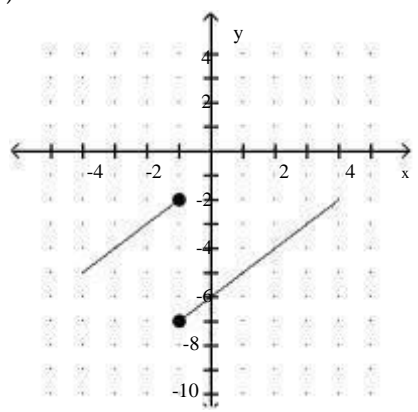

C)

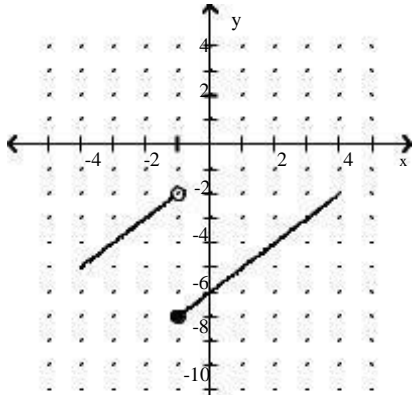

D)

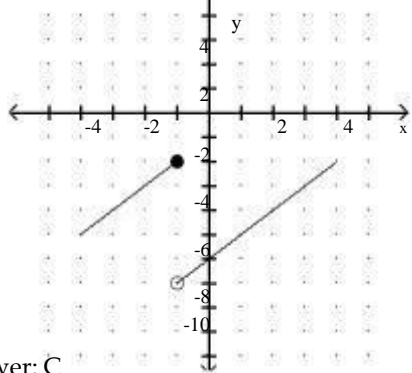

Answer: C

The graph of $y = f(x)$ is shown. Use the graph to answer the question.

43) Is f continuous at $x = -1.5$?

- 4
- 3
- 2
- 1

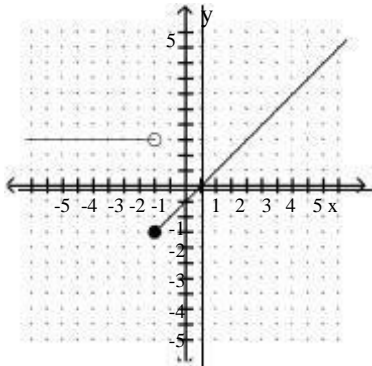

- A) No
- B) Yes

Answer: B

44) Is f continuous at $x = 0$?

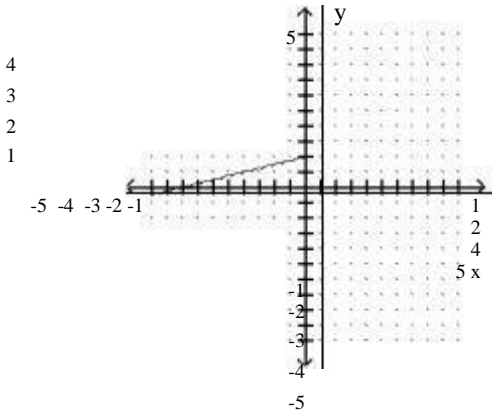

- A) No
- B) Yes

Answer: B

45) Is f continuous at $x = 0$?

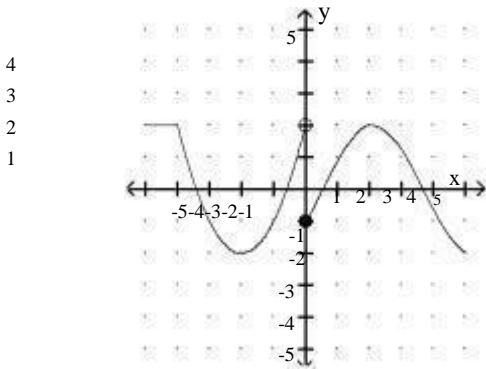

- A) No
- B) Yes

Answer: A

Provide an appropriate response.

46) Determine where the function $H(x) = \frac{x^2 + 7}{x^2 + x - 6}$ is continuous.

- A) $(-\infty, -3) \cup (-3, 2) \cup (2, \infty)$
- B) $(-3, 2) \cup (2, \infty)$
- C) $(-\infty, -3)$
- D) $(-\infty, -3) \cup (-3, 2)$

Answer: A

47) Determine where the function $f(x) = 2x - 3$ is continuous.

- A) $\left[\frac{3}{2}, \infty \right)$
 B) $(-\infty, \infty)$
 C) $\left(-\infty, \frac{3}{2} \right]$
 D) $\left(-\infty, \frac{3}{2} \right) \cup \left(\frac{3}{2}, \infty \right)$

Answer: D

48) Determine the points at which the function is discontinuous.

$$h(x) = \begin{cases} x^2 - 4 & \text{for } x < -1 \\ 0 & \text{for } -1 \leq x \leq 1 \\ x^2 + 4 & \text{for } x > 1 \end{cases}$$

- A) 1
 B) -1, 1
 C) -1, 0, 1
 D) None

Answer: B

49) Use a graphing utility to approximate the partition numbers of the function to four decimal places: $f(x) = x^4 - 8x^2 - 4x + 1$.

- A) $(-\infty, -2.4976)$
 B) $(-\infty, -2.4976) \cup (0.1832, 3.0347)$
 C) $(-\infty, -2.4976) \cup (-2.4976, -0.7203)$
 D) $(-\infty, -2.4976) \cup (-2.4976, -0.7203) \cup (-0.7203, 0.1832) \cup (0.1832, 3.0347)$

Answer: D

50) Use a graphing utility to find the discontinuities of the given rational function.

$$g(x) = \frac{x + 1}{x^3 + 2x^2 + 10x - 13}$$

- A) 3
 B) 1
 C) -1
 D) Continuous at all values of x

Answer: B

51) Use a graphing utility to find the discontinuities of the given rational function.

$$g(x) = \frac{x + 1}{x^3 + 2x^2 + 10x - 13}$$

- A) 3
 B) -1
 C) 1
 D) Continuous at all values of x

Answer: C

52) Use a graphing utility to find the discontinuities of the given rational function.

$$f(x) = \frac{x^2 + 2x + 1}{x^3 + 2x^2 + 5x - 8}$$

- A) 3
- B) -1
- C) 1
- D) Continuous at all values of x

Answer: C

53) Solve the inequality and express the answer in interval notation: $\frac{x^2 - 4x}{x + 5} > 0$.

- A) (-5, 0)
- B) (-5, 0) \cup (4, ∞)
- C) (-5, ∞)
- D) (4, ∞)

Answer: B

54) Use a sign chart to solve the inequality. Express answers in interval notation. $x^2 > 16$

- A) (-4, 4)
- B) (-4, ∞)
- C) (4, ∞)
- D) $(-\infty, -4) \cup (4, \infty)$

Answer: D

55) Use a sign chart to solve the inequality. Express answers in interval notation. $x^2 + 6 < 2x$

- A) {2}
- B) \emptyset
- C) (2, ∞)
- D) $(-\infty, -2)$

Answer: B

56) Use a sign chart to solve the inequality. Express answers in interval notation.

$$\frac{-5}{-3x - 4} > 0$$

- A) $\left(-3\frac{4}{3}, \infty\right)$
- B) $(0, \infty)$
- C) $\left(-\infty, -4\frac{3}{4}\right)$
- D) $\left(-\infty, \frac{4}{3}\right)$

Answer: A

Solve the problem.

57) The cost of renting a snowblower is \$20 for the first hour (or any fraction thereof) and \$5 for each additional hour (or fraction thereof) up to a maximum rental time of 5 hours. Write a piecewise definition of the cost $C(x)$ of renting a snowblower for x hours. Is $C(x)$ continuous at $x = 2.5$?

- A) $C(x) = \begin{cases} 20 & \text{if } 0 \leq x \leq 1 \\ 25 & \text{if } 1 < x \leq 2 \\ 30 & \text{if } 2 < x \leq 3; \text{ No} \\ 35 & \text{if } 3 < x \leq 4 \\ 40 & \text{if } 4 < x \leq 5 \end{cases}$
- B) $C(x) = \begin{cases} 20 & \text{if } 0 < x \leq 1 \\ 25 & \text{if } 1 < x \leq 2 \\ 30 & \text{if } 2 < x \leq 3; \text{ Yes} \\ 35 & \text{if } 3 < x \leq 4 \\ 40 & \text{if } 4 < x \leq 5 \end{cases}$
- C) $C(x) = \begin{cases} 20 & \text{if } 0 < x \leq 1 \\ 25 & \text{if } 1 < x \leq 2 \\ 30 & \text{if } 2 < x \leq 3; \text{ No} \\ 35 & \text{if } 3 < x \leq 4 \\ 40 & \text{if } 4 < x \leq 5 \\ 25 & \text{if } 0 < x \leq 1 \\ 30 & \text{if } 1 < x \leq 2 \end{cases}$
- D) $C(x) = \begin{cases} 35 & \text{if } 2 < x \leq 3; \\ \text{No} & \\ 40 & \text{if } 3 < x \leq 4 \\ 45 & \text{if } 4 < x \leq 5 \end{cases}$

Answer: B

Find average rate of change for the function over the given interval.

58) $y = x^2 + 6x$ between $x = 5$ and $x = 9$

- A) $\frac{135}{4}$
- B) $\frac{80}{9}$
- C) 15
- D) 20

Answer: D

59) $y = 7x^3 + 7x^2 + 3$ between $x = -6$ and $x = -1$

- A) $\frac{252}{3}$
- B) $\frac{5}{3}$
- C) -3
- D) -1260

Answer: A

60) Find the average rate of change for $f(x) = \sqrt{2x}$ if x changes from 2 to 8.

A) 7

B) 2

C) $3\frac{1}{10}$

D) $3\frac{3}{10}$

Answer: C

61) Find the average rate of change of y with respect to x if x changes from 3 to 5 in the function $y = x^2 + 3x$.

A) 9

B) 11

C) 4

D) 22

Answer: B

Find the instantaneous rate of change for the function at the value given.

62) Find the instantaneous rate of change for the function $x^2 + 4x$ at $x = 6$.

A) 16

B) 10

C) 12

D) 60

Answer: A

63) Find the instantaneous rate of change for the function $f(x) = 5x^2 + x$ at $x = -4$.

A) -14

B) -39

C) -41

D) 6

Answer: B

Provide an appropriate response.

64) Use the four step process to find $f'(x)$ for the function $f(x) = 5x^2 - 3x$.

A) $10x - 3$

B) $5h - 3$

2

C) $5h - 3h$

D) $10x + 5h - 3$

Answer: D

65) Use the four step process to find $f'(x)$ for the function $f(x) = \frac{2}{x^2}$.

- A) $\frac{(h+2x)}{x^2(x+h)^2}$
 B) $\frac{2(h+x)}{x^2(x+h)^2}$
 C) $-\frac{2(h+2x)}{x^2(x+h)^2}$
 D) $-\frac{2(h+2x+2x)}{x^2(x+h)^2}$

Answer: C

66) Use the four step process to find $f'(x)$ for the function $f(x) = \frac{x}{6-x}$.

- A) $\frac{6}{(x-6)(x+h-6)}$
 B) $-\frac{1}{(x-6)(x+h-6)}$
 C) $\frac{1}{(x-6)(x+h-6)}$
 D) $-\frac{6}{h(x-6)(x+h-6)}$

Answer: A

Use the definition $f'(x) = \lim_{h \rightarrow 0} \frac{f(x+h) - f(x)}{h}$ to find the derivative at x .

67) $f(x) = 9x - 16$

- A) -9
 B) 9
 C) 9x
 D) -7

Answer: B

68) $f(x) = 10 - 14x^2$

- A) $-28x^2$
 B) $-28x$
 C) $10 - 28x$
 D) $10 - 14x$

Answer: B

69) $f(x) = 4x + 9x^3$

- A) $4x + 27x^2$
 B) $4x + 27x^3$
 C) $4 + 27x^2$
 D) $4 + 9x^2$

Answer: C

Provide an appropriate response.

70) Find the slope of the secant line joining $(2, f(2))$ and $(3, f(3))$ for $f(x) = -3x^2 - 8$.

- A) -55
- B) 55
- C) 15
- D) -15

Answer: D

71) Find the slope of the graph $f(x) = -x^2 + 3x$ at the point $(1, 2)$.

- A) 1
- B) -1
- C) 2
- D) -2

Answer: A

72) Find the slope of the line tangent to the graph of the function at the given value of x . $y = x^4 + 2x^3 + 2x + 2$ at $x = -3$

- A) -52
- B) 65
- C) 67
- D) -50

Answer: A

73) Given $f(x + h) - f(x) = 4xh + 4h + 2h^2$, find the slope of the tangent line at $x = 4$.

- A) 20
- B) 22
- C) 8
- D) 16

Answer: A

Find the equation of the tangent line to the curve when x has the given value.

74) $f(x) = -4 - x^2$; $x = 4$

- A) $y = -2x$
- B) $y = 8x - 12$
- C) $y = -8x + 12$
- D) $y = 4x + 12$

Answer: C

75) Find the equation of the tangent line to the graph of the function at the given value of x . $f(x) = x^2 + 5x$ at $x = 4$

- A) $y = 13x - 16$
- B) $y = -\frac{4}{25}x + 5\frac{8}{25}$
- C) $y = \frac{1}{20}x + 5$
- D) $y = -39x - 80$

Answer: A

Solve the problem.

76) Suppose an object moves along the y-axis so that its location is $y = f(x) = x^2 + x$ at time x (y is in meters and x is in seconds). Find the average velocity (the average rate of change of y with respect to x) for x changing from 2 to 9 seconds.

- A) 84 m/s
- B) 15 m/s
- C) 3 m/s
- D) 12 m/s

Answer: D

77) Suppose an object moves along the y-axis so that its location is $y = f(x) = x^2 + x$ at time x (y is in meters and x is in seconds). Find the average velocity for x changing from 3 to $3 + h$ seconds.

- A) $12 - h$ m/s
- B) $12 + h$ m/s
- C) $7 - h$ m/s
- D) $7 + h$ m/s

Answer: D

78) Suppose an object moves along the y-axis so that its location is $y = f(x) = x^2 + x$ at time x (y is in meters and x is in seconds). Find the instantaneous velocity at $x = 4$ seconds.

- A) 8 m/s
- B) 10 m/s
- C) 9 m/s
- D) 20 m/s

Answer: C

List the x -values in the graph at which the function is not differentiable.

79)

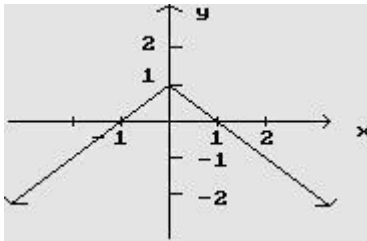

- A) $x = 1$
- B) $x = -1$
- C) $x = 0$
- D) $x = 2$

Answer: C

80)

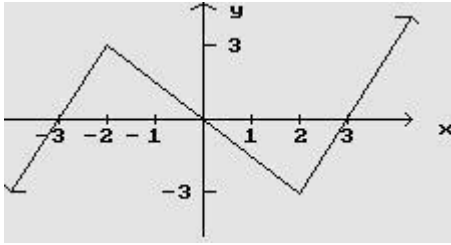

- A) $x = -2, x = 0, x = 2$
- B) $x = -3, x = 3$
- C) $x = -2, x = 2$
- D) $x = -3, x = 0, x = 3$

Answer: C

81)

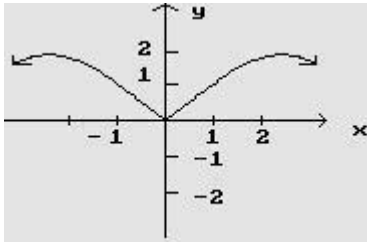

- A) $x = -2, x = 0, x = 2$
- B) $x = 2$
- C) $x = 0$
- D) $x = -2, x = 2$

Answer: C

Solve the problem.

82) If an object moves along a line so that it is at $y = f(x) = 2x^2 - 7x - 6$ at time x (in seconds), find the instantaneous velocity function $v = f'(x)$.

- A) $2x^2 - 7$
- B) $4x^2 - 7$
- C) $4x - 7$
- D) $2x - 7$

Answer: C

83) If an object moves along a line so that it is at $y = f(x) = 8x^2$ at time x (in seconds), find the velocity at $x = 1$ (y is measured in feet).

- A) 8 ft / s
- B) 160 ft/s
- C) 6 ft/sec
- D) 16 ft / s

Answer: D

- 84) The electric power p (in W) as a function of the current i (in A) in a certain circuit is given by $p(i) = 10i^2 + 63i$. Find the instantaneous rate of change of p with respect to i for $i = 0.9$ A.
- A) 72 W/A
 - B) 81 W/A
 - C) 74.7 W/A
 - D) 64.8 W/A

Answer: B

Provide an appropriate response.

- 85) Find $f'(x)$ if $f(x) = \pi$.
- A) $f'(x) = \pi$
 - B) $f'(x) = 0$
 - C) $f'(x) = 1$
 - D) $f'(x) = \pi^2$

Answer: B

- 86) Find y' if $y = 8^{\frac{5}{x}}$.
- A) 1
 - B) $8^{\frac{5}{x}} x$
 - C) 0
 - D) $8^{\frac{5}{x}}$

Answer: C

- 87) Find y' if $y = 6x$.
- A) x^2
 - B) 6
 - C) 0
 - D) x

Answer: B

- 88) Find $f'(x)$ for $f(x) = 2x^5 + 6x^8$.
- A) $2x^4 + 6x^7$
 - B) $10x^6 + 48x^9$
 - C) $10x^4 + 48x^7$
 - D) $10x^3 + 48x^2$

Answer: C

- 89) Find the derivative of $y = \frac{3x^5 - 7x^2}{x^4}$

A) $y' = 9x^2 + 8x^{-3}$

B) $y' = 18x^{-2} + 8x^{-3}$

C) $y' = 9x + 8x^3$

D) $y' = 9x^2 + 8x^3$

Answer: A

90) Let f and g be functions that satisfy $f'(4) = 2$ and $g'(4) = -3$. Find $h'(4)$ for $h(x) = 3f(x) - g(x) + 2$.

- A) 9
- B) 11
- C) 5
- D) 2

Answer: A

91) Find $f'(x)$ if $f(x) = 3x^4 + 6x^7$.

- A) $12x^3 + 42x^6$
- B) $4x^3 + 7x^6$
- C) $7x^3 + 13x^6$
- D) $3x^5 + 7x^8$

Answer: A

92) Find $f'(x)$ if $f(x) = 6x^2 + 8x^3 + 11x$.

- A) $f(x) = -12x^{-1} + 24x^2$
- B) $f(x) = -12x^{-1} + 24x^2 + 11$
- C) $f(x) = -12x^{-3} + 24x^2$
- D) $f(x) = -12x^{-3} + 24x^2 + 11$

Answer: D

93) Find $f'(x)$ if $f(x) = 9x^{7/5} - 5x^2 + 10000$.

- A) $f(x) = \frac{63}{5}x^{2/5} - 10x$
- B) $f(x) = \frac{63}{5}x^{6/5} - 10x$
- C) $f(x) = \frac{63}{5}x^{6/5} - 10x + 4000$
- D) $f(x) = \frac{63}{5}x^{2/5} - 10x + 4000$

Answer: A

94) Find: $\frac{d}{dx} \left(\frac{4}{x^4} - 4\sqrt[5]{x} \right)$

- A) $-\frac{16}{x^5} - \frac{4}{5\sqrt[5]{x^4}}$
- B) $-20x^{-5}$

C) $-\frac{16}{x^5} - \frac{4}{5\sqrt[5]{x^4}}$

D) $\frac{1}{5} - \frac{4}{5\sqrt[5]{x^4}}$

Answer: C

95) Find: $\frac{dy}{dt}$ if $y = 3t^{-4} - 5t^{-1}$ dt

A) $-12t^{-5} - 5t^{-2}$

B) $-12t^{-5} - 5t^{-2}$

C) $-12t^{-5} - 5t^{-2}$

D) $-12t^{-5} + 5t^{-2}$

A) $\frac{1}{4x^3} - \frac{5}{3}x^{-2/3}$

B) $4x^{-5} - 15x^{2/3}$

C) $\frac{1}{x^3} + \frac{5}{3}x^{-4/3}$

D) $16x^{-5} - 35x^{-2/3}$

Answer: D

97) Find $\frac{dv}{dt}$ ($6v^{0.7} - v^{5.8}$)

A) $4.2v^{-0.3} - 5.8v^{4.8}$

B) $4.2v^{-0.3} - 5.8v^{4.7}$

C) $4.2v^{-0.3} - 5.8v^{-4.7}$

D) $4.2v^{-0.3} - 5.8v^{-4.8}$

Answer: A

98) Find $\frac{dy}{dx}$ for $y = \frac{1}{x^2} + \frac{x^7}{7}$

A) $-x^{-2} + \frac{7}{10}x^6$

B) $\frac{7x^6}{9x^2 + 10}$

C) $-\frac{2}{x^3} + \frac{7x^6}{9x^2 + 10}$

D) $-x^{-2} + \frac{7}{10}x^6$

Answer: D

- 99) Find the equation of the tangent line at $x = 7$ for $f(x) = 6 - x^2$. Write the answer in the form $y = mx + b$.
- A) $y = -14x + 55$
 - B) $y = -2x$
 - C) $y = 7x + 55$
 - D) $y = 14x - 55$

Answer: A

- 100) Find the equation of the tangent line at $x = -6$ for $f(x) = \frac{x^3}{3}$. Write the answer in the form $y = mx + b$.
- A) $y = 216x + 18$
 - B) $y = 54x + 216$
 - C) $y = 18x + 216$
 - D) $y = 216x + 54$

Answer: B

- 101) Find the values of x where the tangent line is horizontal for $f(x) = 3x^3 - 2x^2 - 9$.

- A) $x = 0, x = -9^{\frac{4}{3}}$
- B) $x = 0, x = 9^{\frac{4}{3}}$
- C) $x = 0, x = -3^{\frac{2}{3}}$
- D) $x = 0, x = 3^{\frac{2}{3}}$

Answer: B

- 102) Find the equation of the tangent line at $x = 2$ for $f(x) = 4 + x - 2x^2 - 3x^3$. Write the answer in the form $y = mx + b$.
- A) $y = -39x + 52$
 - B) $y = -43x + 60$
 - C) $y = -47x + 68$
 - D) $y = -43x + 48$

Answer: B

Solve the problem.

- 103) An object moves along the y -axis (marked in feet) so that its position at time t (in seconds) is given by $f(t) = 9t^3 - 9t^2 + t + 7$. Find the velocity at three seconds.
- A) 192 feet per second
 - B) 197 feet per second
 - C) 190 feet per second
 - D) 109 feet per second

Answer: C

104) A pen manufacturer determined that the total cost in dollars of producing x dozen pens in one day is given by:

$$C(x) = 350 + 2x - 0.01x^2, \quad 0 \leq x \leq 100$$

- A) The marginal cost is \$0.58/doz. The cost of producing 1 dozen more pens at a production level of 70 dozen pens is approximately \$0.58.
- B) The marginal cost is \$0.60/doz. The cost of producing 1 dozen more pens at a production level of 70 dozen pens is approximately \$0.60.
- C) The marginal cost is \$0.62/doz. The cost of producing 1 dozen more pens at a production level of 70 dozen pens is approximately \$0.62.
- D) The marginal cost is \$0.59/doz. The cost of producing 1 dozen more pens at a production level of 70 dozen pens is approximately \$0.59.

105) According to one theory of learning, the number of items, $w(t)$, that a person can learn after t hours of instruction is given by:

$$w(t) = 15\sqrt{3t^2}, \quad 0 \leq t \leq 64$$

- A) 5 items per hour
- B) 45 items per hour
- C) 20 items per hour
- D) 60 items per hour

Answer: A

Find Δy for the given values of x_1 and x_2 .

106) $y = 2x + 3$; $x = 18$, $\Delta x = 0.5$

- A) 5
- B) 0.1
- C) 0.5
- D) 1

Answer: D

Find dy .

107) $y = 5x^2 - 7x - 7$

- A) $10x - 7 dx$
- B) $10x dx$
- C) $10x - 14 dx$
- D) $(10x - 7) dx$

Answer: D

108) $y = x\sqrt{5x+1}$

A) $\frac{15x-2}{2\sqrt{5x+1}} dx$

B) $\frac{15x-2}{\sqrt{5x+1}} dx$

C) $\frac{15x+2}{2\sqrt{5x+1}} dx$

D) $\frac{15x+2}{\sqrt{5x+1}} dx$

Answer: C

Provide an appropriate response.

109) Evaluate dy and Δy for $y = f(x) = x^2 - 7x + 5$, $x = 7$, and $dx = \Delta x = 0.5$.

A) $dy = 3.5$; $\Delta y = 3.75$

B) $dy = 3.5$; $\Delta y = 3.5$

C) $dy = 3.75$; $\Delta y = 3.75$

D) $dy = 3.75$; $\Delta y = 3.5$

Answer: A

110) Evaluate dy and Δy for $y = f(x) = 20 + 15x^2 - x^3$, $x = 2$, and $dx = \Delta x = 0.3$.

A) $dy = 15.183$; $\Delta y = 14.4$

B) $dy = 14.4$; $\Delta y = 15.183$

C) $dy = 14.4$; $\Delta y = 14.4$

D) $dy = 15.183$; $\Delta y = 15.183$

Answer: B

111) A spherical balloon is being inflated. Find the approximate change in volume if the radius increases from

6.2 cm to 6.4 cm. (Recall that $V = \frac{4}{3}\pi r^3$.)

A) $0.992\pi \text{ cm}^3$

B) $153.76\pi \text{ cm}^3$

C) 317.77 cm^3

D) $30.752\pi \text{ cm}^3$

Answer: D

Solve the problem.

112) A cube 4 inches on an edge is given a protective coating 0.1 inches thick. About how much coating should a production manager order for 900 cubes?

A) About 4320 in.²

B) About 5760 in.³

C) About 1440 in.²

D) About 8640 in.³

Answer: D

113) One hour after x milligrams of a particular drug are given to a person, the change in body temperature T (in degrees Fahrenheit) is given by $T = x^2 \left(1 - \frac{x}{9} \right)$, where $0 \leq x \leq 3$. Approximate the changes in body temperature produced by changing the drug dosage from 1 to 1.9 milligrams. Round to the nearest hundredth when necessary.

- A) 0.22°F
- B) 1.5°F
- C) 1.67°F
- D) 3.17°F

Answer: B

114) $V = \frac{4}{3} \pi r^3$, where r is the radius, in centimeters. By approximately how much does the volume of a sphere increase when the radius is increased from 1.0 cm to 1.1 cm? (Use 3.14 for π .)

- A) 1.1 cm^3
- B) 1.3 cm^3
- C) 1.5 cm^3
- D) 0.1 cm^3

Answer: B

Provide an appropriate response.

115) Suppose that the total profit in hundreds of dollars from selling x items is given by $P(x) = 4x^2 - 5x + 10$. Find the marginal profit at $x = 5$.

- A) \$32
- B) \$15
- C) \$35
- D) \$45

Answer: C

116) The revenue (in thousands of dollars) from producing x units of an item is modeled by $R(x) = 5x - 0.0005x^2$. Find the marginal revenue at $x = 1000$.

- A) \$4.50
- B) \$104.00
- C) \$10,300.00
- D) \$4.00

Answer: D

117) Let $C(x)$ be the cost function and $R(x)$ the revenue function. Compute the marginal cost, marginal revenue, and the marginal profit functions.

$$C(x) = 0.0004x^3 - 0.036x^2 + 200x + 40,000$$

$$R(x) = 450x$$

A) $C'(x) = 0.0012x^2 - 0.072x + 200$ $R'(x) = 450$

$$P'(x) = -0.0012x^2 + 0.072x + 250$$

B) $C'(x) = 0.0012x^2 - 0.072x + 200$ $R'(x) = 450$

$$P'(x) = 0.0012x^2 - 0.072x - 250$$

C) $C'(x) = 0.0012x^2 + 0.072x + 200$ $R'(x) = 450$

$$P'(x) = 0.0012x^2 + 0.072x + 250$$

Answer: A

118) The total cost to produce x units of paint is $C(x) = (5x + 3)(7x + 4)$. Find the marginal average cost function.

A) $\bar{C}'(x) = 70x + 41$

B) $\bar{C}'(x) = 35x + 41 + \frac{12}{x}$

C) $\bar{C}'(x) = 70 - \frac{41}{x}$

D) $\bar{C}'(x) = 35 - \frac{12}{x^2}$

Answer: D

119) The total profit from selling x units of doorknobs is $P(x) = (6x - 7)(9x - 8)$. Find the marginal average profit function.

A) $\bar{P}'(x) = 54 - \frac{56}{x}$

B) $\bar{P}'(x) = 54x - 111$

C) $\bar{P}'(x) = 54x - 56$

D) $\bar{P}'(x) = 54 - \frac{111}{x^2}$

Answer: A

120) The total cost in dollars of producing x lawn mowers is given by $C(x) = 4,000 + 90x - \frac{x^2}{3}$. Find the marginal average cost at $x = 20$, $\bar{C}'(20)$ and interpret the result.

A) -\$13.33; a unit increase in production will decrease the average cost per unit by approximately \$13.33 at a production level of 20 units.

B) -\$10.33; a unit increase in production will decrease the average cost per unit by approximately \$10.33 at a production level of 20 units.

C) -\$20.33; a unit increase in production will decrease the average cost per unit by approximately \$20.33 at a production level of 20 units.

D) -\$1.33; a unit increase in production will decrease the average cost per unit by approximately \$1.33 at a production level of 20 units.

Answer: B

Solve the problem.

- 121) The demand equation for a certain item is $p = 14 - \frac{x}{1,000}$ and the cost equation is $C(x) = 7,000 + 4x$. Find the

marginal profit at a production level of 3,000 and interpret the result.

- A) \$14; at the 3,000 level of production, profit will increase by approximately \$14 for each unit increase in production.
- B) \$16; at the 3,000 level of production, profit will increase by approximately \$16 for each unit increase in production.
- C) \$7; at the 3,000 level of production, profit will increase by approximately \$7 for each unit increase in production.
- D) \$4; at the 3,000 level of production, profit will increase by approximately \$4 for each unit increase in production.

Answer: D

- 122) A company is planning to manufacture a new blender. After conducting extensive market surveys, the research department estimates a weekly demand of 600 blenders at a price of \$50 per blender and a weekly demand of 800 blenders at a price of \$40 per blender. Assuming the demand equation is linear, use the research department's estimates to find the revenue equation in terms of the demand x .

A) $R(x) = 80x - 20x^2$

B) $R(x) = 80x -$

C) $R(x) = 20x + \frac{x^2}{20}$

D) $R(x) = 80x - 20$

Answer: B

- 123) Suppose the demand for a certain item is given by $D(p) = -3p^2 + 4p + 8$, where p represents the price of the item. Find $D'(p)$, the rate of change of demand with respect to price.

A) $D'(p) = -3p + 4$

B) $D'(p) = -6p + 4$

C) $D'(p) = -3p^2 + 4$

D) $D'(p) = -6p^2 + 4$

Answer: B

