

Solution Manual for College Algebra Essentials 5th Edition by Blitzer

ISBN 0134469291 9780134469294

Full link download

Solution Manual:

<https://testbankpack.com/p/solution-manual-for-college-algebra-essentials-5th-edition-by-blitzer-isbn-0134469291-9780134469294/>

Test Bank:

<https://testbankpack.com/p/test-bank-for-college-algebra-essentials-5th-edition-by-blitzer-isbn-0134469291-9780134469294/>

Chapter 2

Functions and Graphs

Section 2.1

Check Point Exercises

1. The domain is the set of all first components: {0, 10, 20, 30, 42}. The range is the set of all second components: {9.1, 6.7, 10.7, 13.2, 21.7}.

2. a. The relation is not a function since the two ordered pairs (5, 6) and (5, 8) have the same first component but different second components.

b. The relation is a function since no two ordered pairs have the same first component and different second components.

3. a. $2x + y = 6$
 $y = 6 - 2x$

For each value of x , there is one and only one value for y , so the equation defines y as a function of x .

b. $x^2 + y^2 = 1$
 $y^2 = 1 - x^2$
 $y = \pm \sqrt{1 - x^2}$

Since there are values of x (all values between -1 and 1 exclusive) that give more than one value for y (for example, if $x = 0$, then

$y = \pm \sqrt{1 - 0^2} = \pm 1$), the equation does not define y as a function of x .

4. a. $f(-5) = (-5)^2 - 2(-5) + 7$
 $= 25 - (-10) + 7$
 $= 42$

b. $f(x + 4) = (x + 4)^2 - 2(x + 4) + 7$
 $= x^2 + 8x + 16 - 2x - 8 + 7$
 $= x^2 + 6x + 15$

c. $f(-x) = (-x)^2 - 2(-x) + 7$
 $= x^2 - (-2x) + 7$
 $= x^2 + 2x + 7$

5.

x	$f(x) = 2x$	(x, y)
-2	-4	(-2, -4)
-1	-2	(-1, -2)
0	0	(0, 0)
1	2	(1, 2)
2	4	(2, 4)

x	$g(x) = 2x - 3$	(x, y)
-2	$g(-2) = 2(-2) - 3 = -7$	(-2, -7)
-1	$g(-1) = 2(-1) - 3 = -5$	(-1, -5)
0	$g(0) = 2(0) - 3 = -3$	(0, -3)
1	$g(1) = 2(1) - 3 = -1$	(1, -1)
2	$g(2) = 2(2) - 3 = 1$	(2, 1)

The graph of g is the graph of f shifted down 3 units.

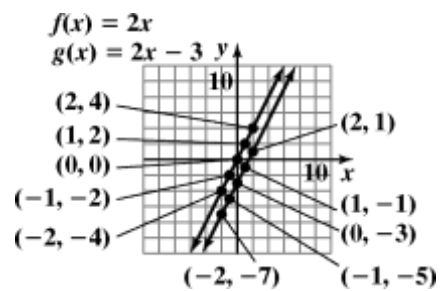

6. The graph (a) passes the vertical line test and is therefore a function.
The graph (b) fails the vertical line test and is therefore not a function.
The graph (c) passes the vertical line test and is therefore a function.
The graph (d) fails the vertical line test and is therefore not a function.
7. a. $f(5) = 400$
b. $x = 9, f(9) = 100$
c. The minimum T cell count in the asymptomatic stage is approximately 425.
8. a. domain: $\{x | -2 \leq x \leq 1\}$ or $[-2, 1]$.
range: $\{y | 0 \leq y \leq 3\}$ or $[0, 3]$.
b. domain: $\{x | -2 < x \leq 1\}$ or $(-2, 1]$.
range: $\{y | -1 \leq y < 2\}$ or $[-1, 2)$.
c. domain: $\{x | -3 \leq x < 0\}$ or $[-3, 0)$.
range: $\{y | y = -3, -2, -1\}$.

Concept and Vocabulary Check 2.1

- relation; domain; range
- function
- $f; x$
- true
- false
- $x; x + 6$
- ordered pairs
- more than once; function
- $[0, 3)$; domain
- $[1, \infty)$; range
- $0; 0$; zeros
- false

Exercise Set 2.1

- The relation is a function since no two ordered pairs have the same first component and different second components. The domain is $\{1, 3, 5\}$ and the range is $\{2, 4, 5\}$.
- The relation is a function because no two ordered pairs have the same first component and different second components. The domain is $\{4, 6, 8\}$ and the range is $\{5, 7, 8\}$.
- The relation is not a function since the two ordered pairs $(3, 4)$ and $(3, 5)$ have the same first component but different second components (the same could be said for the ordered pairs $(4, 4)$ and $(4, 5)$). The domain is $\{3, 4\}$ and the range is $\{4, 5\}$.
- The relation is not a function since the two ordered pairs $(5, 6)$ and $(5, 7)$ have the same first component but different second components (the same could be said for the ordered pairs $(6, 6)$ and $(6, 7)$). The domain is $\{5, 6\}$ and the range is $\{6, 7\}$.
- The relation is a function because no two ordered pairs have the same first component and different second components. The domain is $\{3, 4, 5, 7\}$ and the range is $\{-2, 1, 9\}$.
- The relation is a function because no two ordered pairs have the same first component and different second components. The domain is $\{-2, -1, 5, 10\}$ and the range is $\{1, 4, 6\}$.
- The relation is a function since there are no same first components with different second components. The domain is $\{-3, -2, -1, 0\}$ and the range is $\{-3, -2, -1, 0\}$.
- The relation is a function since there are no ordered pairs that have the same first component but different second components. The domain is $\{-7, -5, -3, 0\}$ and the range is $\{-7, -5, -3, 0\}$.
- The relation is not a function since there are ordered pairs with the same first component and different second components. The domain is $\{1\}$ and the range is $\{4, 5, 6\}$.
- The relation is a function since there are no two ordered pairs that have the same first component and different second components. The domain is $\{4, 5, 6\}$ and the range is $\{1\}$.

11. $x + y = 16$
 $y = 16 - x$
 Since only one value of y can be obtained for each value of x , y is a function of x .

12. $x + y = 25$
 $y = 25 - x$
 Since only one value of y can be obtained for each value of x , y is a function of x .

13. $x^2 + y = 16$
 $y = 16 - x^2$
 Since only one value of y can be obtained for each value of x , y is a function of x .

14. $x^2 + y = 25$
 $y = 25 - x^2$
 Since only one value of y can be obtained for each value of x , y is a function of x .

15. $x^2 + y^2 = 16$
 $y^2 = 16 - x^2$
 $y = \pm \sqrt{16 - x^2}$
 If $x = 0$, $y = \pm 4$.
 Since two values, $y = 4$ and $y = -4$, can be obtained for one value of x , y is not a function of x .

16. $x^2 + y^2 = 25$
 $y^2 = 25 - x^2$
 $y = \pm \sqrt{25 - x^2}$
 If $x = 0$, $y = \pm 5$.
 Since two values, $y = 5$ and $y = -5$, can be obtained for one value of x , y is not a function of x .

17. $x = y^2$
 $y = \pm \sqrt{x}$
 If $x = 1$, $y = \pm 1$.
 Since two values, $y = 1$ and $y = -1$, can be obtained for $x = 1$, y is not a function of x .

18. $4x = y^2$
 $y = \pm \sqrt{4x} = \pm 2\sqrt{x}$
 If $x = 1$, then $y = \pm 2$.
 Since two values, $y = 2$ and $y = -2$, can be obtained for $x = 1$, y is not a function of x .

19. $y = \sqrt{x+4}$
 Since only one value of y can be obtained for each value of x , y is a function of x .

20. $y = -\sqrt{x+4}$
 Since only one value of y can be obtained for each value of x , y is a function of x .

21. $x + y^3 = 8$
 $y^3 = 8 - x$
 $y = \sqrt[3]{8 - x}$
 Since only one value of y can be obtained for each value of x , y is a function of x .

22. $x + y^3 = 27$
 $y^3 = 27 - x$
 $y = \sqrt[3]{27 - x}$
 Since only one value of y can be obtained for each value of x , y is a function of x .

23. $xy + 2y = 1$
 $y(x+2) = 1$
 $y = \frac{1}{x+2}$
 Since only one value of y can be obtained for each value of x , y is a function of x .

24. $xy - 5y = 1$
 $y(x-5) = 1$
 $y = \frac{1}{x-5}$
 Since only one value of y can be obtained for each value of x , y is a function of x .

25. $|x| - y = 2$
 $-y = -|x| + 2$
 $y = |x| - 2$
 Since only one value of y can be obtained for each value of x , y is a function of x .

26. $|x| - y = 5$
 $-y = -|x| + 5$
 $y = |x| - 5$
 Since only one value of y can be obtained for each value of x , y is a function of x .

27. a. $f(6) = 4(6) + 5 = 29$
 b. $f(x + 1) = 4(x + 1) + 5 = 4x + 9$
 c. $f(-x) = 4(-x) + 5 = -4x + 5$
28. a. $f(4) = 3(4) + 7 = 19$
 b. $f(x + 1) = 3(x + 1) + 7 = 3x + 10$
 c. $f(-x) = 3(-x) + 7 = -3x + 7$
29. a. $g(-1) = (-1)^2 + 2(-1) + 3$
 $= 1 - 2 + 3$
 $= 2$
 b. $g(x + 5) = (x + 5)^2 + 2(x + 5) + 3$
 $= x^2 + 10x + 25 + 2x + 10 + 3$
 $= x^2 + 12x + 38$
 c. $g(-x) = (-x)^2 + 2(-x) + 3$
 $= x^2 - 2x + 3$
30. a. $g(-1) = (-1)^2 - 10(-1) - 3$
 $= 1 + 10 - 3$
 $= 8$
 b. $g(x + 2) = (x + 2)^2 - 10(x + 2) - 3$
 $= x^2 + 4x + 4 - 10x - 20 - 3$
 $= x^2 - 6x - 19$
 c. $g(-x) = (-x)^2 - 10(-x) - 3$
 $= x^2 + 10x - 3$
31. a. $h(2) = 2^4 - 2^2 + 1$
 $= 16 - 4 + 1$
 $= 13$
 b. $h(-1) = (-1)^4 - (-1)^2 + 1$
 $= 1 - 1 + 1$
 $= 1$
 c. $h(-x) = (-x)^4 - (-x)^2 + 1 = x^4 - x^2 + 1$
 d. $h(3a) = (3a)^4 - (3a)^2 + 1$
 $= 81a^4 - 9a^2 + 1$
32. a. $h(3) = 3^3 - 3 + 1 = 25$
 b. $h(-2) = (-2)^3 - (-2) + 1$
 $= -8 + 2 + 1$
 $= -5$
 c. $h(-x) = (-x)^3 - (-x) + 1 = -x^3 + x + 1$
 d. $h(3a) = (3a)^3 - (3a) + 1$
 $= 27a^3 - 3a + 1$
33. a. $f(-6) = \sqrt{6 + 6} + 3 = 0\sqrt{3} + 3 = 3$
 b. $f(10) = \sqrt{10 + 6} + 3$
 $= \sqrt{16} + 3$
 $= 4 + 3$
 $= 7$
 c. $f(x - 6) = \sqrt{x - 6 + 6} + 3 = x\sqrt{3} + 3$
34. a. $f(16) = \frac{25 - 16}{\sqrt{\quad}} - 6 = \frac{9}{\sqrt{\quad}} - 6 = 3 - 6 = -3$
 b. $f(-24) = \sqrt[3]{5 - (-24)} - 6$
 $= \sqrt[3]{49} - 6$
 $= 7 - 6 = 1$
 c. $f(25 - 2x) = \sqrt[3]{5 - (25 - 2x)} - 6$
 $= \sqrt[3]{2x - 6} - 6$
35. a. $f(2) = \frac{4(2)^2 - 1}{2^2} = \frac{15}{4}$
 $\frac{4(-2)^2 - 1}{(-2)^2} = \frac{15}{4}$
 b. $f(-2) = \frac{4(-2)^2 - 1}{(-2)^2} = \frac{15}{4}$
 c. $f(-x) = \frac{4(-x)^2 - 1}{(-x)^2} = \frac{4x^2 - 1}{x^2}$
 $\frac{4(2)^3 + 1}{2^3} = \frac{33}{8}$
36. a. $f(2) = \frac{4(-2)^3 + 1}{(-2)^3} = \frac{-31}{-8} = \frac{31}{8}$
 b. $f(-2) = \frac{4(-2)^3 + 1}{(-2)^3} = \frac{-31}{-8} = \frac{31}{8}$
 c. $f(-x) = \frac{4(-x)^3 + 1}{(-x)^3} = \frac{-4x^3 + 1}{-x^3}$
 $\frac{4x^3 - 1}{x^3}$
 or $\frac{4x^3 - 1}{x^3}$

37. a. $f(6) = \frac{6}{|6|} = 1$

b. $f(-6) = \frac{-6}{|-6|} = \frac{-6}{6} = -1$

c. $f(r^2) = \frac{r^2}{|r^2|} = \frac{r^2}{r^2} = 1$

38. a. $f(5) = \frac{|5+3|}{5+3} = \frac{|8|}{8} = 1$

b. $f(-5) = \frac{|-5+3|}{-5+3} = \frac{|-2|}{-2} = \frac{2}{-2} = -1$

c. $f(-9-x) = \frac{|-9-x+3|}{-9-x+3}$
 $= \frac{|-x-6|}{-x-6} = \begin{cases} 1, & \text{if } x < -6 \\ -1, & \text{if } x > -6 \end{cases}$

39.

x	$f(x) = x$	(x, y)
-2	$f(-2) = -2$	$(-2, -2)$
-1	$f(-1) = -1$	$(-1, -1)$
0	$f(0) = 0$	$(0, 0)$
1	$f(1) = 1$	$(1, 1)$
2	$f(2) = 2$	$(2, 2)$

x	$g(x) = x + 3$	(x, y)
-2	$g(-2) = -2 + 3 = 1$	$(-2, 1)$
-1	$g(-1) = -1 + 3 = 2$	$(-1, 2)$
0	$g(0) = 0 + 3 = 3$	$(0, 3)$
1	$g(1) = 1 + 3 = 4$	$(1, 4)$
2	$g(2) = 2 + 3 = 5$	$(2, 5)$

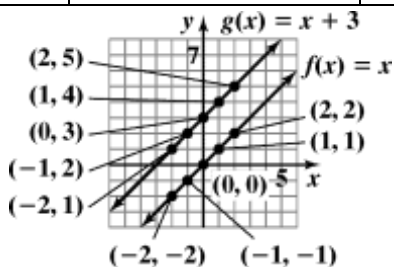

The graph of g is the graph of f shifted up 3 units.

40.

x	$f(x) = x$	(x, y)
-2	$f(-2) = -2$	$(-2, -2)$
-1	$f(-1) = -1$	$(-1, -1)$
0	$f(0) = 0$	$(0, 0)$
1	$f(1) = 1$	$(1, 1)$
2	$f(2) = 2$	$(2, 2)$

x	$g(x) = x - 4$	(x, y)
-2	$g(-2) = -2 - 4 = -6$	$(-2, -6)$
-1	$g(-1) = -1 - 4 = -5$	$(-1, -5)$
0	$g(0) = 0 - 4 = -4$	$(0, -4)$
1	$g(1) = 1 - 4 = -3$	$(1, -3)$
2	$g(2) = 2 - 4 = -2$	$(2, -2)$

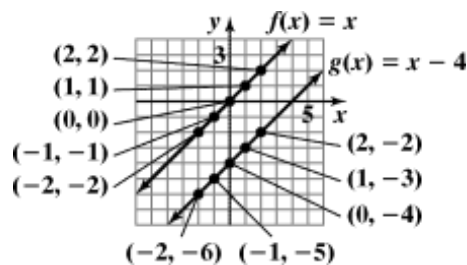

The graph of g is the graph of f shifted down 4 units.

41.

x	$f(x) = -2x$	(x, y)
-2	$f(-2) = -2(-2) = 4$	$(-2, 4)$
-1	$f(-1) = -2(-1) = 2$	$(-1, 2)$
0	$f(0) = -2(0) = 0$	$(0, 0)$
1	$f(1) = -2(1) = -2$	$(1, -2)$
2	$f(2) = -2(2) = -4$	$(2, -4)$

x	$g(x) = -2x - 1$	(x, y)
-2	$g(-2) = -2(-2) - 1 = 3$	$(-2, 3)$
-1	$g(-1) = -2(-1) - 1 = 1$	$(-1, 1)$
0	$g(0) = -2(0) - 1 = -1$	$(0, -1)$
1	$g(1) = -2(1) - 1 = -3$	$(1, -3)$
2	$g(2) = -2(2) - 1 = -5$	$(2, -5)$

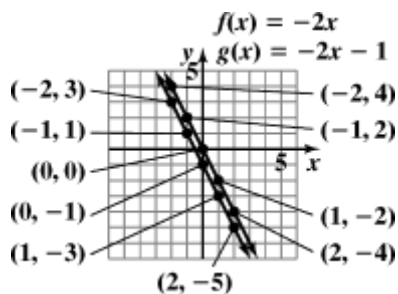

The graph of g is the graph of f shifted down 1 unit.

42.

x	$f(x) = -2x$	(x, y)
-2	$f(-2) = -2(-2) = 4$	$(-2, 4)$
-1	$f(-1) = -2(-1) = 2$	$(-1, 2)$
0	$f(0) = -2(0) = 0$	$(0, 0)$
1	$f(1) = -2(1) = -2$	$(1, -2)$
2	$f(2) = -2(2) = -4$	$(2, -4)$

x	$g(x) = -2x + 3$	(x, y)
-2	$g(-2) = -2(-2) + 3 = 7$	$(-2, 7)$
-1	$g(-1) = -2(-1) + 3 = 5$	$(-1, 5)$
0	$g(0) = -2(0) + 3 = 3$	$(0, 3)$
1	$g(1) = -2(1) + 3 = 1$	$(1, 1)$
2	$g(2) = -2(2) + 3 = -1$	$(2, -1)$

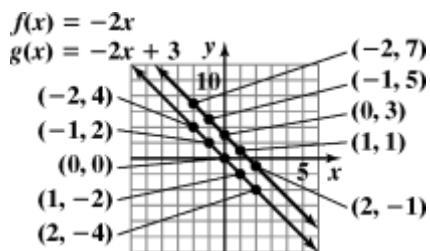

The graph of g is the graph of f shifted up 3 units.

43.

x	$f(x) = x^2$	(x, y)
-2	$f(-2) = (-2)^2 = 4$	$(-2, 4)$
-1	$f(-1) = (-1)^2 = 1$	$(-1, 1)$
0	$f(0) = (0)^2 = 0$	$(0, 0)$
1	$f(1) = (1)^2 = 1$	$(1, 1)$
2	$f(2) = (2)^2 = 4$	$(2, 4)$

x	$g(x) = x^2 + 1$	(x, y)
-2	$g(-2) = (-2)^2 + 1 = 5$	$(-2, 5)$
-1	$g(-1) = (-1)^2 + 1 = 2$	$(-1, 2)$
0	$g(0) = (0)^2 + 1 = 1$	$(0, 1)$
1	$g(1) = (1)^2 + 1 = 2$	$(1, 2)$
2	$g(2) = (2)^2 + 1 = 5$	$(2, 5)$

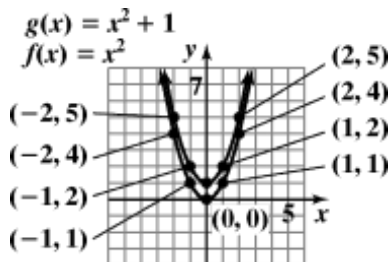

The graph of g is the graph of f shifted up 1 unit.

44.

x	$f(x) = x^2$	(x, y)
-2	$f(-2) = (-2)^2 = 4$	$(-2, 4)$
-1	$f(-1) = (-1)^2 = 1$	$(-1, 1)$
0	$f(0) = (0)^2 = 0$	$(0, 0)$
1	$f(1) = (1)^2 = 1$	$(1, 1)$
2	$f(2) = (2)^2 = 4$	$(2, 4)$

x	$g(x) = x^2 - 2$	(x, y)
-2	$g(-2) = (-2)^2 - 2 = 2$	$(-2, 2)$
-1	$g(-1) = (-1)^2 - 2 = -1$	$(-1, -1)$
0	$g(0) = (0)^2 - 2 = -2$	$(0, -2)$
1	$g(1) = (1)^2 - 2 = -1$	$(1, -1)$
2	$g(2) = (2)^2 - 2 = 2$	$(2, 2)$

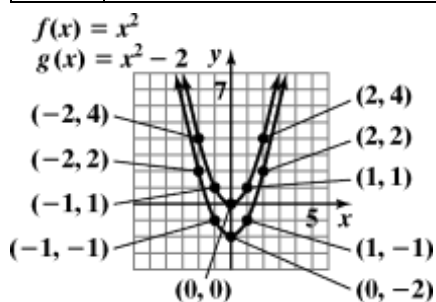

The graph of g is the graph of f shifted down 2 units.

45.

x	$f(x) = x $	(x, y)
-2	$f(-2) = -2 = 2$	$(-2, 2)$
-1	$f(-1) = -1 = 1$	$(-1, 1)$
0	$f(0) = 0 = 0$	$(0, 0)$
1	$f(1) = 1 = 1$	$(1, 1)$
2	$f(2) = 2 = 2$	$(2, 2)$

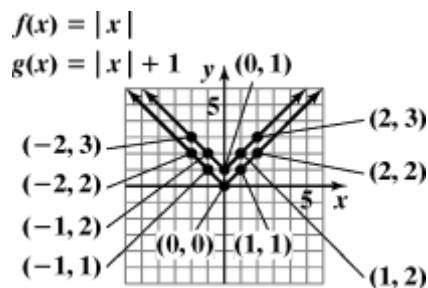

The graph of g is the graph of f shifted up 1 unit.

47.

x	$f(x) = x^3$	(x, y)
-2	$f(-2) = (-2)^3 = -8$	$(-2, -8)$
-1	$f(-1) = (-1)^3 = -1$	$(-1, -1)$
0	$f(0) = (0)^3 = 0$	$(0, 0)$
1	$f(1) = (1)^3 = 1$	$(1, 1)$
2	$f(2) = (2)^3 = 8$	$(2, 8)$

x	$g(x) = x^3 + 2$	(x, y)
-2	$g(-2) = (-2)^3 + 2 = -6$	$(-2, -6)$
-1	$g(-1) = (-1)^3 + 2 = 1$	$(-1, 1)$
0	$g(0) = (0)^3 + 2 = 2$	$(0, 2)$
1	$g(1) = (1)^3 + 2 = 3$	$(1, 3)$
2	$g(2) = (2)^3 + 2 = 10$	$(2, 10)$

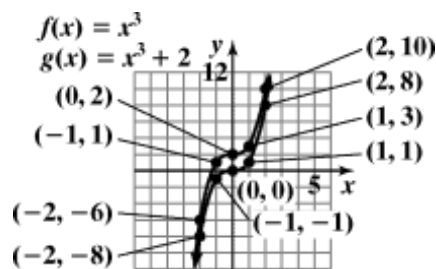

The graph of g is the graph of f shifted up 2 units.

x	$g(x) = x - 2$	(x, y)
-2	$g(-2) = -2 - 2 = 0$	$(-2, 0)$
-1	$g(-1) = -1 - 2 = -1$	$(-1, -1)$
0	$g(0) = 0 - 2 = -2$	$(0, -2)$
1	$g(1) = 1 - 2 = -1$	$(1, -1)$
2	$g(2) = 2 - 2 = 0$	$(2, 0)$

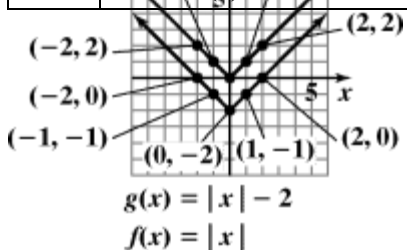

The graph of g is the graph of f shifted down 2 units.

x	$f(x) = x$	(x, y)
-2	$f(-2) = -2 = -2$	$(-2, -2)$
-1	$f(-1) = -1 = -1$	$(-1, -1)$
0	$f(0) = 0 = 0$	$(0, 0)$
1	$f(1) = 1 = 1$	$(1, 1)$
2	$f(2) = 2 = 2$	$(2, 2)$

46.

x	$g(x) = x + 1$	(x, y)
-2	$g(-2) = -2 + 1 = 3$	$(-2, 3)$
-1	$g(-1) = -1 + 1 = 2$	$(-1, 2)$
0	$g(0) = 0 + 1 = 1$	$(0, 1)$
1	$g(1) = 1 + 1 = 2$	$(1, 2)$
2	$g(2) = 2 + 1 = 3$	$(2, 3)$

48.

x	$f(x) = x^3$	(x, y)
-2	$f(-2) = (-2)^3 = -8$	$(-2, -8)$
-1	$f(-1) = (-1)^3 = -1$	$(-1, -1)$
0	$f(0) = (0)^3 = 0$	$(0, 0)$
1	$f(1) = (1)^3 = 1$	$(1, 1)$
2	$f(2) = (2)^3 = 8$	$(2, 8)$

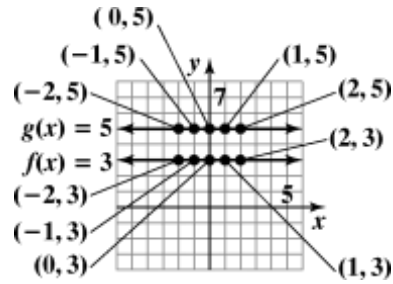

The graph of g is the graph of f shifted up 2 units.

x	$g(x) = x^3 - 1$	(x, y)
-2	$g(-2) = (-2)^3 - 1 = -9$	$(-2, -9)$
-1	$g(-1) = (-1)^3 - 1 = -2$	$(-1, -2)$
0	$g(0) = (0)^3 - 1 = -1$	$(0, -1)$
1	$g(1) = (1)^3 - 1 = 0$	$(1, 0)$
2	$g(2) = (2)^3 - 1 = 7$	$(2, 7)$

50.

x	$f(x) = -1$	(x, y)
-2	$f(-2) = -1$	$(-2, -1)$
-1	$f(-1) = -1$	$(-1, -1)$
0	$f(0) = -1$	$(0, -1)$
1	$f(1) = -1$	$(1, -1)$
2	$f(2) = -1$	$(2, -1)$

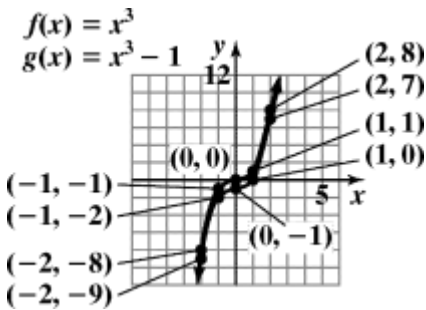

The graph of g is the graph of f shifted down 1 unit.

x	$g(x) = 4$	(x, y)
-2	$g(-2) = 4$	$(-2, 4)$
-1	$g(-1) = 4$	$(-1, 4)$
0	$g(0) = 4$	$(0, 4)$
1	$g(1) = 4$	$(1, 4)$
2	$g(2) = 4$	$(2, 4)$

49.

x	$f(x) = 3$	(x, y)
-2	$f(-2) = 3$	$(-2, 3)$
-1	$f(-1) = 3$	$(-1, 3)$
0	$f(0) = 3$	$(0, 3)$
1	$f(1) = 3$	$(1, 3)$
2	$f(2) = 3$	$(2, 3)$

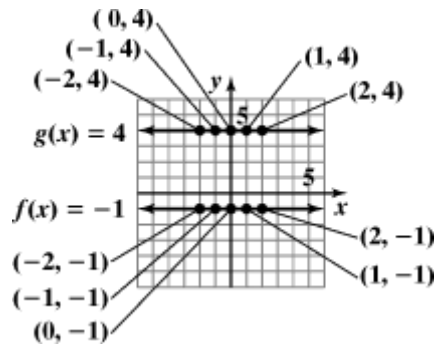

The graph of g is the graph of f shifted up 5 units.

x	$g(x) = 5$	(x, y)
-2	$g(-2) = 5$	$(-2, 5)$
-1	$g(-1) = 5$	$(-1, 5)$
0	$g(0) = 5$	$(0, 5)$
1	$g(1) = 5$	$(1, 5)$
2	$g(2) = 5$	$(2, 5)$

51.

x	$f(x) = \sqrt{x}$	(x, y)
0	$f(0) = \sqrt{0} = 0$	(0, 0)
1	$f(1) = \sqrt{1} = 1$	(1, 1)
4	$f(4) = \sqrt{4} = 2$	(4, 2)
9	$f(9) = \sqrt{9} = 3$	(9, 3)

x	$g(x) = \sqrt{x} - 1$	(x, y)
0	$g(0) = \sqrt{0} - 1 = -1$	(0, -1)
1	$g(1) = \sqrt{1} - 1 = 0$	(1, 0)
4	$g(4) = \sqrt{4} - 1 = 1$	(4, 1)
9	$g(9) = \sqrt{9} - 1 = 2$	(9, 2)

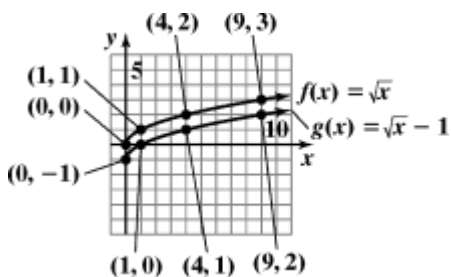

The graph of g is the graph of f shifted down 1 unit.

52.

x	$f(x) = \sqrt{x}$	(x, y)
0	$f(0) = \sqrt{0} = 0$	(0, 0)
1	$f(1) = \sqrt{1} = 1$	(1, 1)
4	$f(4) = \sqrt{4} = 2$	(4, 2)
9	$f(9) = \sqrt{9} = 3$	(9, 3)

x	$g(x) = \sqrt{x} + 2$	(x, y)
0	$g(0) = \sqrt{0} + 2 = 2$	(0, 2)
1	$g(1) = \sqrt{1} + 2 = 3$	(1, 3)
4	$g(4) = \sqrt{4} + 2 = 4$	(4, 4)
9	$g(9) = \sqrt{9} + 2 = 5$	(9, 5)

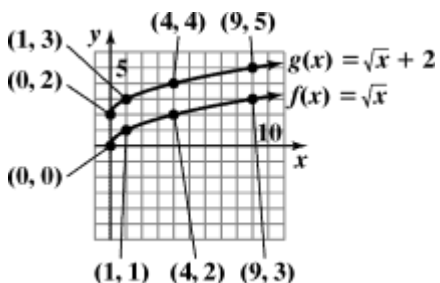

The graph of g is the graph of f shifted up 2 units.

53.

x	$f(x) = \sqrt{x}$	(x, y)
0	$f(0) = \sqrt{0} = 0$	(0, 0)
1	$f(1) = \sqrt{1} = 1$	(1, 1)
4	$f(4) = \sqrt{4} = 2$	(4, 2)
9	$f(9) = \sqrt{9} = 3$	(9, 3)

x	$g(x) = \sqrt{x-1}$	(x, y)
1	$g(1) = \sqrt{1-1} = 0$	(1, 0)
2	$g(2) = \sqrt{2-1} = 1$	(2, 1)
5	$g(5) = \sqrt{5-1} = 2$	(5, 2)
10	$g(10) = \sqrt{10-1} = 3$	(10, 3)

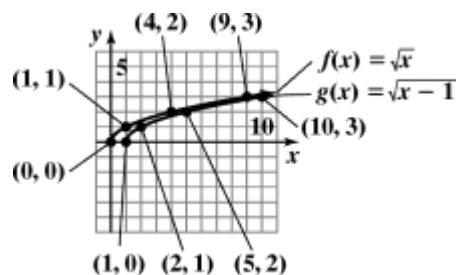

The graph of g is the graph of f shifted right 1 unit.

54.

x	$f(x) = \sqrt{x}$	(x, y)
0	$f(0) = \sqrt{0} = 0$	(0, 0)
1	$f(1) = \sqrt{1} = 1$	(1, 1)
4	$f(4) = \sqrt{4} = 2$	(4, 2)
9	$f(9) = \sqrt{9} = 3$	(9, 3)

x	$g(x) = \sqrt{x+2}$	(x, y)
-2	$g(-2) = \sqrt{-2+2} = 0$	(-2, 0)
-1	$g(-1) = \sqrt{-1+2} = 1$	(-1, 1)
2	$g(2) = \sqrt{2+2} = 2$	(2, 2)
7	$g(7) = \sqrt{7+2} = 3$	(7, 3)

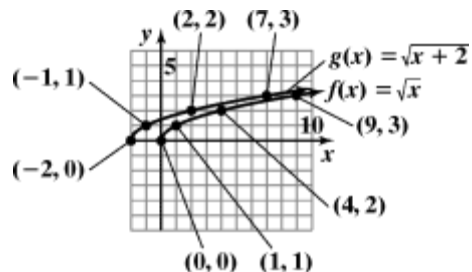

The graph of g is the graph of f shifted left 2 units.

Chapter 2 Functions and Graphs

55. function
56. function
57. function
58. not a function
59. not a function
60. not a function
61. function
62. not a function
63. function
64. function
65. $f(-2) = -4$
66. $f(2) = -4$
67. $f(4) = 4$
68. $f(-4) = 4$
69. $f(-3) = 0$
70. $f(-1) = 0$
71. $g(-4) = 2$
72. $g(2) = -2$
73. $g(-10) = 2$
74. $g(10) = -2$
75. When $x = -2$, $g(x) = 1$.
76. When $x = 1$, $g(x) = -1$.
77. a. domain: $(-\infty, \infty)$
- b. range: $[-4, \infty)$
- c. x -intercepts: -3 and 1
- d. y -intercept: -3
- e. $f(-2) = -3$ and $f(2) = 5$
78. a. domain: $(-\infty, \infty)$
- b. range: $(-\infty, 4]$
- c. x -intercepts: -3 and 1
- d. y -intercept: 3
- e. $f(-2) = 3$ and $f(2) = -5$
79. a. domain: $(-\infty, \infty)$
- b. range: $[1, \infty)$
- c. x -intercept: none
- d. y -intercept: 1
- e. $f(-1) = 2$ and $f(3) = 4$
80. a. domain: $(-\infty, \infty)$
- b. range: $[0, \infty)$
- c. x -intercept: -1
- d. y -intercept: 1
- e. $f(-4) = 3$ and $f(3) = 4$
81. a. domain: $[0, 5)$
- b. range: $[-1, 5)$
- c. x -intercept: 2
- d. y -intercept: -1
- e. $f(3) = 1$
82. a. domain: $(-6, 0]$
- b. range: $[-3, 4)$
- c. x -intercept: -3.75
- d. y -intercept: -3
- e. $f(-5) = 2$
83. a. domain: $[0, \infty)$
- b. range: $[1, \infty)$
- c. x -intercept: none
- d. y -intercept: 1
- e. $f(4) = 3$

84. a. domain: $[-1, \infty)$
 b. range: $[0, \infty)$
 c. x -intercept: -1
 d. y -intercept: 1
 e. $f(3) = 2$
85. a. domain: $[-2, 6]$
 b. range: $[-2, 6]$
 c. x -intercept: 4
 d. y -intercept: 4
 e. $f(-1) = 5$
86. a. domain: $[-3, 2]$
 b. range: $[-5, 5]$
 c. x -intercept: $-\frac{1}{2}$
 d. y -intercept: 1
 e. $f(-2) = -3$
87. a. domain: $(-\infty, \infty)$
 b. range: $(-\infty, -2]$
 c. x -intercept: none
 d. y -intercept: -2
 e. $f(-4) = -5$ and $f(4) = -2$
88. a. domain: $(-\infty, \infty)$
 b. range: $[0, \infty)$
 c. x -intercept: $\{x \mid x \leq 0\}$
 d. y -intercept: 0
 e. $f(-2) = 0$ and $f(2) = 4$
89. a. domain: $(-\infty, \infty)$
 b. range: $(0, \infty)$
 c. x -intercept: none
 d. y -intercept: 1.5
 e. $f(4) = 6$
90. a. domain: $(-\infty, 1) \cup (1, \infty)$
 b. range: $(-\infty, 0) \cup (0, \infty)$
 c. x -intercept: none
 d. y -intercept: -1
 e. $f(2) = 1$
91. a. domain: $\{-5, -2, 0, 1, 3\}$
 b. range: $\{2\}$
 c. x -intercept: none
 d. y -intercept: 2
 e. $f(-5) + f(3) = 2 + 2 = 4$
92. a. domain: $\{-5, -2, 0, 1, 4\}$
 b. range: $\{-2\}$
 c. x -intercept: none
 d. y -intercept: -2
 e. $f(-5) + f(4) = -2 + (-2) = -4$
93. $g(1) = 3(1) - 5 = 3 - 5 = -2$
 $f(g(1)) = f(-2) = (-2)^2 - (-2) + 4$
 $= 4 + 2 + 4 = 10$
94. $g(-1) = 3(-1) - 5 = -3 - 5 = -8$
 $f(g(-1)) = f(-8) = (-8)^2 - (-8) + 4$
 $= 64 + 8 + 4 = 76$
95. $\sqrt{3 - (-1)} - (-6)^2 + 6 \div (-6) \cdot 4$
 $= \sqrt{3 + 1} - 36 + 6 \div (-6) \cdot 4$
 $= 4\sqrt{1} - 36 + -1 \cdot 4$
 $= 2 - 36 + -4$
 $= -34 + -4$
 $= -38$
96. $|-4 - (-1)| - (-3)^2 + -3 \div 3 \cdot -6$
 $= |-4 + 1| - 9 + -3 \div 3 \cdot -6$
 $= |-3| - 9 + -1 \cdot -6$
 $= 3 - 9 + 6 = -6 + 6 = 0$
97. $f(-x) - f(x)$
 $= (-x)^3 + (-x) - 5 - (x^3 + x - 5)$
 $= -x^3 - x - 5 - x^3 - x + 5 = -2x^3 - 2x$

98. $f(-x) - f(x)$
 $= (-x)^2 - 3(-x) + 7 - (x^2 - 3x + 7)$
 $= x^2 + 3x + 7 - x^2 + 3x - 7$
 $= 6x$
99. a. {(Iceland, 9.7), (Finland, 9.6), (New Zealand, 9.6), (Denmark, 9.5)}
- b. Yes, the relation is a function because each country in the domain corresponds to exactly one corruption rating in the range.
- c. {(9.7, Iceland), (9.6, Finland), (9.6, New Zealand), (9.5, Denmark)}
- d. No, the relation is not a function because 9.6 in the domain corresponds to two countries in the range, Finland and New Zealand.
100. a. {(Bangladesh, 1.7), (Chad, 1.7), (Haiti, 1.8), (Myanmar, 1.8)}
- b. Yes, the relation is a function because each country in the domain corresponds to exactly one corruption rating in the range.
- c. {(1.7, Bangladesh), (1.7, Chad), (1.8, Haiti), (1.8, Myanmar)}
- d. No, the relation is not a function because 1.7 in the domain corresponds to two countries in the range, Bangladesh and Chad.
101. a. $f(70) = 83$ which means the chance that a 60-year old will survive to age 70 is 83%.
- b. $g(70) = 76$ which means the chance that a 60-year old will survive to age 70 is 76%.
- c. Function f is the better model.
102. a. $f(90) = 25$ which means the chance that a 60-year old will survive to age 90 is 25%.
- b. $g(90) = 10$ which means the chance that a 60-year old will survive to age 90 is 10%.
- c. Function f is the better model.
103. a. $G(30) = -0.01(30)^2 + (30) + 60 = 81$
 In 2010, the wage gap was 81%. This is represented as (30, 81) on the graph.
- b. $G(30)$ underestimates the actual data shown by the bar graph by 2%.
104. a. $G(10) = -0.01(10)^2 + (10) + 60 = 69$
 In 1990, the wage gap was 69%. This is represented as (10, 69) on the graph.
- b. $G(10)$ underestimates the actual data shown by the bar graph by 2%.
105. $C(x) = 100,000 + 100x$
 $C(90) = 100,000 + 100(90) = \$109,000$
 It will cost \$109,000 to produce 90 bicycles.
106. $V(x) = 22,500 - 3200x$
 $V(3) = 22,500 - 3200(3) = \$12,900$
 After 3 years, the car will be worth \$12,900.
107. $T(x) = \frac{40}{x} + \frac{40}{x+30}$
 $T(30) = \frac{40}{30} + \frac{40}{30+30}$
 $= \frac{80}{60} + \frac{40}{60}$
 $= \frac{120}{60}$
 $= 2$
 If you travel 30 mph going and 60 mph returning, your total trip will take 2 hours.
108. $S(x) = 0.10x + 0.60(50 - x)$
 $S(30) = 0.10(30) + 0.60(50 - 30) = 15$
 When 30 mL of the 10% mixture is mixed with 20 mL of the 60% mixture, there will be 15 mL of sodium-iodine in the vaccine.
109. – 117. Answers will vary.
118. makes sense
119. does not make sense; Explanations will vary. Sample explanation: The parentheses used in function notation, such as $f(x)$, do not imply multiplication.

120. does not make sense; Explanations will vary.
Sample explanation: The domain is the number of years worked for the company.

121. does not make sense; Explanations will vary.

Sample explanation: This would not be a function because some elements in the domain would correspond to more than one age in the range.

122. false; Changes to make the statement true will vary.
A sample change is: The domain is $[-4, 4]$.

123. false; Changes to make the statement true will vary.
A sample change is: The range is $[-2, 2]$.

124. true

125. false; Changes to make the statement true will vary.
A sample change is: $f(0) = 0.8$

126. $f(a + h) = 3(a + h) + 7 = 3a + 3h + 7$

$$f(a) = 3a + 7$$

$$\frac{f(a + h) - f(a)}{h}$$

$$= \frac{(3a + 3h + 7) - (3a + 7)}{h}$$

$$= \frac{3a + 3h + 7 - 3a - 7}{h} = \frac{3h}{h} = 3$$

127. Answers will vary.
An example is $\{(1,1), (2,1)\}$

128. It is given that $f(x + y) = f(x) + f(y)$ and $f(1) = 3$.

To find $f(2)$, rewrite 2 as $1 + 1$.

$$f(2) = f(1+1) = f(1) + f(1)$$

$$= 3 + 3 = 6$$

Similarly:

$$f(3) = f(2+1) = f(2) + f(1)$$

$$= 6 + 3 = 9$$

$$f(4) = f(3+1) = f(3) + f(1)$$

$$= 9 + 3 = 12$$

While $f(x + y) = f(x) + f(y)$ is true for this function, it is not true for all functions. It is not true

for $f(x) = x^2$, for example.

129. $-1 + 3(x - 4) = 2x$

$$-1 + 3x - 12 = 2x$$

$$3x - 13 = 2x$$

$$-13 = -x$$

130. $\frac{x-3}{(x-3)^5} - \frac{x-4}{(x-4)} = 5$

$$10 \left(\frac{1}{5} \right)^{-10} \left(\frac{1}{2} \right)^{-10} = 10(5)$$

$$2x - 6 - 5x + 20 = 50$$

$$-3x + 14 = 50$$

$$-3x = 36$$

$$x = -12$$

The solution set is $\{-12\}$.

131. Let x = the number of deaths by snakes, in thousands, in 2014

Let $x + 661$ = the number of deaths by mosquitoes, in thousands, in 2014

Let $x + 106$ = the number of deaths by snails, in thousands, in 2014

$$x + (x + 661) + (x + 106) = 1049$$

$$x + x + 661 + x + 106 = 1049$$

$$3x + 767 = 1049$$

$$3x = 282$$

$$x = 94$$

$x = 94$, thousand deaths by snakes

$x + 661 = 755$, thousand deaths by mosquitoes

$x + 106 = 200$, thousand deaths by snails

132. $C(t) = 20 + 0.40(t - 60)$

$$C(100) = 20 + 0.40(100 - 60)$$

$$= 20 + 0.40(40)$$

$$= 20 + 16$$

$$= 36$$

For 100 calling minutes, the monthly cost is \$36.

133. $f(x) = x + 2, x \leq 1$

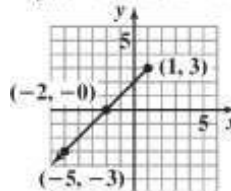

134. $2(x + h) + 3(x + h) + 5 - (2x + 3x + 5)$

$$2$$

$$2$$

$$2(x + h) + 3(x + h) + 5 - (2x + 3x + 5)$$

$$13 = x$$

The solution set is $\{13\}$.

Chapter 2 *Functions and Graphs*

$$= 2(x^2 + 2xh + h^2) + 3x + 3h + 5 - 2x^2 - 3x - 5$$

$$= 2x^2 + 4xh + 2h^2 + 3x + 3h + 5 - 2x^2 - 3x - 5$$

$$= 2x^2 - 2x^2 + 4xh + 2h^2 + 3x - 3x + 3h + 5 - 5$$

$$= 4xh + 2h^2 + 3h$$

Section 2.2

Check Point Exercises

1. The function is increasing on the interval $(-\infty, -1)$, decreasing on the interval $(-1, 1)$, and increasing on the interval $(1, \infty)$.

2. Test for symmetry with respect to the y -axis.

$$y = x^2 - 1$$

$$y = (-x)^2 - 1$$

$$y = x^2 - 1$$

The resulting equation is equivalent to the original. Thus, the graph is symmetric with respect to the y -axis.

Test for symmetry with respect to the x -axis.

$$y = x^2 - 1$$

$$-y = x^2 - 1$$

$$y = -x^2 + 1$$

The resulting equation is not equivalent to the original. Thus, the graph is not symmetric with respect to the x -axis.

Test for symmetry with respect to the origin.

$$y = x^2 - 1$$

$$-y = (-x)^2 - 1$$

$$-y = x^2 - 1$$

$$y = -x^2 + 1$$

The resulting equation is not equivalent to the original. Thus, the graph is not symmetric with respect to the origin.

3. Test for symmetry with respect to the y -axis.

$$y^5 = x^3$$

$$y^5 = (-x)^3$$

$$y^5 = -x^3$$

The resulting equation is not equivalent to the

original. Thus, the graph is not symmetric with respect to the y -axis.

Test for symmetry with respect to the x -axis.

$$y^5 = x^3$$

$$(-y)^5 = x^3$$

$$-y^5 = x^3$$

$$y^5 = -x^3$$

The resulting equation is not equivalent to the original. Thus, the graph is not symmetric with

Test for symmetry with respect to the origin.

$$y^5 = x^3$$

$$(-y)^5 = (-x)^3$$

$$-y^5 = -x^3$$

$$y^5 = x^3$$

The resulting equation is equivalent to the original. Thus, the graph is symmetric with respect to the origin.

4. a. The graph passes the vertical line test and is therefore the graph of a function. The graph is symmetric with respect to the y -axis. Therefore, the graph is that of an even function.
- b. The graph passes the vertical line test and is therefore the graph of a function. The graph is neither symmetric with respect to the y -axis nor the origin. Therefore, the graph is that of a function which is neither even nor odd.
- c. The graph passes the vertical line test and is therefore the graph of a function. The graph is symmetric with respect to the origin. Therefore, the graph is that of an odd function.

5. a. $f(-x) = (-x)^2 + 6 = x^2 + 6 = f(x)$

The function is even. The graph is symmetric with respect to the y -axis.

- b. $g(-x) = 7(-x)^3 - (-x) = -7x^3 + x = -f(x)$

The function is odd. The graph is symmetric with respect to the origin.

- c. $h(-x) = (-x)^5 + 1 = -x^5 + 1$

The function is neither even nor odd. The graph is neither symmetric to the y -axis nor the origin.

$$\lfloor 20 \qquad \qquad \qquad \text{if } 0 \leq t \leq 60$$

6. $C(t) = \begin{cases} 20 + 0.40(t - 60) & \text{if } t > 60 \end{cases}$

- a. Since $0 \leq 40 \leq 60$, $C(40) = 20$ respect to the x -axis.

Chapter 2 Functions and Graphs

With 40 calling minutes,
the cost is \$20. This is
represented by $(40, 20)$.

- b.** Since $80 > 60$,
 $C(80) = 20 + 0.40(80 - 60) = 28$
With 80 calling minutes,
the cost is \$28. This is
represented by $(80, 28)$.

7.

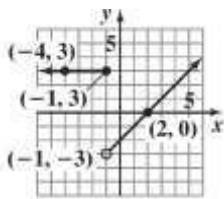

$$f(x) = \begin{cases} 3 & \text{if } x \leq -1 \\ x - 2 & \text{if } x > -1 \end{cases}$$

8. a. $f(x) = -2x^2 + x + 5$
 $f(x+h) = -2(x+h)^2 + (x+h) + 5$
 $= -2(x^2 + 2xh + h^2) + x + h + 5$
 $= -2x^2 - 4xh - 2h^2 + x + h + 5$

b. $\frac{f(x+h) - f(x)}{h}$
 $\frac{-2x^2 - 4xh - 2h^2 + x + h + 5 - (-2x^2 + x + 5)}{h}$
 $= \frac{-4xh - 2h^2 + h}{h}$
 $= \frac{h(-4x - 2h + 1)}{h}$
 $= -4x - 2h + 1, h \neq 0$

Concept and Vocabulary Check 2.2

1. $<f(x_2) ; >f(x_2) ; =f(x_2)$
2. maximum; minimum
3. y-axis
4. x-axis
5. origin
6. $f(x)$; y-axis
7. $-f(x)$; origin
8. piecewise
9. less than or equal to x ; 2; -3 ; 0
10. difference quotient; $x + h$;
11. false
12. false

Exercise Set 2.2

1. a. increasing: $(-1, \infty)$
 b. decreasing: $(-\infty, -1)$
 c. constant: none
2. a. increasing: $(-\infty, -1)$
 b. decreasing: $(-1, \infty)$
 c. constant: none
3. a. increasing: $(0, \infty)$
 b. decreasing: none
 c. constant: none
4. a. increasing: $(-1, \infty)$
 b. decreasing: none
 c. constant: none
5. a. increasing: none
 b. decreasing: $(-2, 6)$
 c. constant: none
6. a. increasing: $(-3, 2)$
 b. decreasing: none
 c. constant: none
7. a. increasing: $(-\infty, -1)$
 b. decreasing: none
 c. constant: $(-1, \infty)$
8. a. increasing: $(0, \infty)$
 b. decreasing: none
 c. constant: $(-\infty, 0)$
9. a. increasing: $(-\infty, 0)$ or $(1.5, 3)$
 b. decreasing: $(0, 1.5)$ or $(3, \infty)$

Chapter 2 Functions and Graphs

$f(x) ; h; h$

c.
con

stant: none

10. a. increasing: $(-5, -4)$ or $(-2, 0)$ or $(2, 4)$

b. decreasing: $(-4, -2)$ or $(0, 2)$ or $(4, 5)$

c. constant: none

11. a. increasing: $(-2, 4)$

b. decreasing: none

c. constant: $(-\infty, -2)$ or $(4, \infty)$

12. a. increasing: none

b. decreasing: $(-4, 2)$

c. constant: $(-\infty, -4)$ or $(2, \infty)$

13. a. $x = 0$, relative maximum = 4

b. $x = -3$, 3, relative minimum = 0

14. a. $x = 0$, relative maximum = 2

b. $x = -3$, 3, relative minimum = -1

15. a. $x = -2$, relative maximum = 21

b. $x = 1$, relative minimum = -6

16. a. $x = 1$, relative maximum = 30

b. $x = 4$, relative minimum = 3

17. Test for symmetry with respect to the y -axis.

$$y = x^2 + 6$$

$$y = (-x)^2 + 6$$

$$y = x^2 + 6$$

The resulting equation is equivalent to the original.

Thus, the graph is symmetric with respect to the y -axis.

Test for symmetry with respect to the x -axis.

$$y = x^2 + 6$$

$$-y = x^2 + 6$$

$$y = -x^2 - 6$$

The resulting equation is not equivalent to the original. Thus, the graph is not symmetric with respect to the x -axis.

Test for symmetry with respect to the origin.

$$y = x^2 + 6$$

$$-y = (-x)^2 + 6$$

$$-y = x^2 + 6$$

$$y = -x^2 - 6$$

The resulting equation is not equivalent to the original. Thus, the graph is not symmetric with respect to the origin.

18. Test for symmetry with respect to the y -axis.

$$y = x^2 - 2$$

$$y = (-x)^2 - 2$$

$$y = x^2 - 2$$

The resulting equation is equivalent to the original. Thus, the graph is symmetric with respect to the y -axis.

Test for symmetry with respect to the x -axis.

$$y = x^2 - 2$$

$$-y = x^2 - 2$$

$$y = -x^2 + 2$$

The resulting equation is not equivalent to the original. Thus, the graph is not symmetric with respect to the x -axis.

Test for symmetry with respect to the origin.

$$y = x^2 - 2$$

$$-y = (-x)^2 - 2$$

$$-y = x^2 - 2$$

$$y = -x^2 + 2$$

The resulting equation is not equivalent to the original. Thus, the graph is not symmetric with respect to the origin.

19. Test for symmetry with respect to the y -axis.

$$x = y^2 + 6$$

$$-x = y^2 + 6$$

$$x = -y^2 - 6$$

The resulting equation is not equivalent to the original. Thus, the graph is not symmetric with respect to the y -axis.

Test for symmetry with respect to the x -axis.

$$x = y^2 + 6$$

$$x = (-y)^2 + 6$$

$$x = y^2 + 6$$

The resulting equation is equivalent to the original. Thus, the graph is symmetric with respect to the x -axis.

Test for symmetry with respect to the origin.

$$x = y^2 + 6$$

$$-x = (-y)^2 + 6$$

$$-x = y^2 + 6$$

$$x = -y^2 - 6$$

The resulting equation is not equivalent to the original. Thus, the graph is not symmetric with respect to the origin.

20. Test for symmetry with respect to the y -axis.

$$x = y^2 - 2$$

$$-x = y^2 - 2$$

$$x = -y^2 + 2$$

The resulting equation is not equivalent to the original. Thus, the graph is not symmetric with respect to the y -axis.

Test for symmetry with respect to the x -axis.

$$x = y^2 - 2$$

$$x = (-y)^2 - 2$$

$$x = y^2 - 2$$

The resulting equation is equivalent to the original. Thus, the graph is symmetric with respect to the x -axis.

Test for symmetry with respect to the origin.

$$x = y^2 - 2$$

$$-x = (-y)^2 - 2$$

$$-x = y^2 - 2$$

$$x = -y^2 + 2$$

The resulting equation is not equivalent to the original. Thus, the graph is not symmetric with respect to the origin.

21. Test for symmetry with respect to the y -axis.

$$y^2 = x^2 + 6$$

$$y^2 = (-x)^2 + 6$$

$$y^2 = x^2 + 6$$

The resulting equation is equivalent to the original. Thus, the graph is symmetric with respect to the y -axis.

Test for symmetry with respect to the x -axis.

$$y^2 = x^2 + 6$$

$$(-y)^2 = x^2 + 6$$

$$y^2 = x^2 + 6$$

The resulting equation is equivalent to the original. Thus, the graph is symmetric with respect to the x -axis.

Test for symmetry with respect to the origin.

$$y^2 = x^2 + 6$$

$$(-y)^2 = (-x)^2 + 6$$

$$y = x^2 + 6$$

The resulting equation is equivalent to the original. Thus, the graph is symmetric with respect to the origin.

22. Test for symmetry with respect to the y -axis.

$$y^2 = x^2 - 2$$

$$y^2 = (-x)^2 - 2$$

$$y^2 = x^2 - 2$$

The resulting equation is equivalent to the original. Thus, the graph is symmetric with respect to the y -axis.

Test for symmetry with respect to the x -axis.

$$y^2 = x^2 - 2$$

$$(-y)^2 = x^2 - 2$$

$$y^2 = x^2 - 2$$

The resulting equation is equivalent to the original. Thus, the graph is symmetric with respect to the x -axis.

Test for symmetry with respect to the origin.

$$y^2 = x^2 - 2$$

$$(-y)^2 = (-x)^2 - 2$$

$$y = x^2 - 2$$

The resulting equation is equivalent to the original. Thus, the graph is symmetric with respect to the origin.

23. Test for symmetry with respect to the y -axis.

$$y = 2x + 3$$

$$y = 2(-x) + 3$$

$$y = -2x + 3$$

The resulting equation is not equivalent to the original. Thus, the graph is not symmetric with respect to the y -axis.

Test for symmetry with respect to the x -axis.

$$y = 2x + 3$$

$$-y = 2x + 3$$

$$y = -2x - 3$$

The resulting equation is not equivalent to the original. Thus, the graph is not symmetric with respect to the x -axis.

Test for symmetry with respect to the origin.

$$y = 2x + 3$$

$$-y = 2(-x) + 3$$

$$y = 2x - 3$$

The resulting equation is not equivalent to the original. Thus, the graph is not symmetric with respect to the origin.

24. Test for symmetry with respect to the y -axis.

$$y = 2x + 5$$

$$y = 2(-x) + 5$$

$$y = -2x + 5$$

The resulting equation is not equivalent to the original. Thus, the graph is not symmetric with respect to the y -axis.

Test for symmetry with respect to the x -axis.

$$y = 2x + 5$$

$$-y = 2x + 5$$

$$y = -2x - 5$$

The resulting equation is not equivalent to the original. Thus, the graph is not symmetric with respect to the x -axis.

Test for symmetry with respect to the origin.

$$y = 2x + 5$$

$$-y = 2(-x) + 5$$

$$y = 2x - 5$$

The resulting equation is not equivalent to the original. Thus, the graph is not symmetric with respect to the origin.

25. Test for symmetry with respect to the y -axis.

$$x_2^2 - y_3^3 = 2$$

$$(-x) - y = 2$$

$$x^2 - y^3 = 2$$

The resulting equation is equivalent to the original. Thus, the graph is symmetric with respect to the y -axis.

Test for symmetry with respect to the x -axis.

$$x^2 - y^3 = 2$$

$$x^2 - (-y)^3 = 2$$

$$x^2 + y^3 = 2$$

The resulting equation is not equivalent to the original. Thus, the graph is not symmetric with respect to the x -axis.

Test for symmetry with respect to the origin.

$$x^2 - y^3 = 2$$

$$(-x)^2 - (-y)^3 = 2$$

$$x^2 + y^3 = 2$$

The resulting equation is not equivalent to the original. Thus, the graph is not symmetric with respect to the origin.

26. Test for symmetry with respect to the y -axis.

$$x_3^3 - y^2 = 5$$

$$(-x) - y^2 = 5$$

$$-x^3 - y^2 = 5$$

The resulting equation is not equivalent to the original. Thus, the graph is not symmetric with respect to the y -axis.

Test for symmetry with respect to the x -axis.

$$x^3 - y^2 = 5$$

$$x^3 - (-y)^2 = 5$$

$$x^3 - y^2 = 5$$

The resulting equation is equivalent to the original. Thus, the graph is symmetric with respect to the x -axis.

Test for symmetry with respect to the origin.

$$x^3 - y^2 = 5$$

$$(-x)^3 - (-y)^2 = 5$$

$$-x^3 - y^2 = 5$$

The resulting equation is not equivalent to the original. Thus, the graph is not symmetric with respect to the origin.

27. Test for symmetry with respect to the y -axis.

$$x^2 + y^2 = 100$$

$$(-x)^2 + y^2 = 100$$

$$x^2 + y^2 = 100$$

The resulting equation is equivalent to the original. Thus, the graph is symmetric with respect to the y -axis.

Test for symmetry with respect to the x -axis.

$$x^2 + y^2 = 100$$

$$x^2 + (-y)^2 = 100$$

$$x^2 + y^2 = 100$$

The resulting equation is equivalent to the original. Thus, the graph is symmetric with respect to the x -axis.

Test for symmetry with respect to the origin.

$$x^2 + y^2 = 100$$

$$(-x)^2 + (-y)^2 = 100$$

$$x^2 + y^2 = 100$$

The resulting equation is equivalent to the original. Thus, the graph is symmetric with respect to the origin.

28. Test for symmetry with respect to the y-axis.

$$x^2 + y^2 = 49$$

$$(-x)^2 + y^2 = 49$$

$$x^2 + y^2 = 49$$

The resulting equation is equivalent to the original. Thus, the graph is symmetric with respect to the y-axis.

Test for symmetry with respect to the x-axis.

$$x^2 + y^2 = 49$$

$$x^2 + (-y)^2 = 49$$

$$x^2 + y^2 = 49$$

The resulting equation is equivalent to the original. Thus, the graph is symmetric with respect to the x-axis.

Test for symmetry with respect to the origin.

$$x^2 + y^2 = 49$$

$$(-x)^2 + (-y)^2 = 49$$

$$x^2 + y^2 = 49$$

The resulting equation is equivalent to the original. Thus, the graph is symmetric with respect to the origin.

29. Test for symmetry with respect to the y-axis.

$$x^2 y^2 + 3xy = 1$$

$$(-x)^2 y^2 + 3(-x)y = 1$$

$$x^2 y^2 - 3xy = 1$$

The resulting equation is not equivalent to the original. Thus, the graph is not symmetric with respect to the y-axis.

Test for symmetry with respect to the x-axis.

$$x^2 y^2 + 3xy = 1$$

$$x^2 (-y)^2 + 3x(-y) = 1$$

$$x^2 y^2 - 3xy = 1$$

The resulting equation is equivalent to the original. Thus, the graph is symmetric with respect to the x-axis.

Test for symmetry with respect to the origin.

$$x^2 y^2 + 3xy = 1$$

$$(-x)^2 (-y)^2 + 3(-x)(-y) = 1$$

$$x^2 y^2 + 3xy = 1$$

The resulting equation is equivalent to the original. Thus, the graph is symmetric with respect to the origin.

Test for symmetry with respect to the y-axis.

$$x^2 y^2 + 5xy = 2$$

$$(-x)^2 y^2 + 5(-x)y = 2$$

$$x^2 y^2 - 5xy = 2$$

The resulting equation is not equivalent to the original. Thus, the graph is not symmetric with respect to the y-axis.

Test for symmetry with respect to the x-axis.

$$x^2 y^2 + 5xy = 2$$

$$x^2 (-y)^2 + 5x(-y) = 2$$

$$x^2 y^2 - 5xy = 2$$

The resulting equation is equivalent to the original. Thus, the graph is symmetric with respect to the x-axis.

Test for symmetry with respect to the origin.

$$x^2 y^2 + 5xy = 2$$

$$(-x)^2 (-y)^2 + 5(-x)(-y) = 2$$

$$x^2 y^2 + 5xy = 2$$

The resulting equation is equivalent to the original. Thus, the graph is symmetric with respect to the origin.

Test for symmetry with respect to the y-axis.

$$y^4 = x^3 + 6$$

$$y^4 = (-x)^3 + 6$$

$$y^4 = -x^3 + 6$$

The resulting equation is not equivalent to the original. Thus, the graph is not symmetric with respect to the y-axis.

Test for symmetry with respect to the x-axis.

$$y^4 = x^3 + 6$$

$$(-y)^4 = x^3 + 6$$

$$y^4 = x^3 + 6$$

The resulting equation is equivalent to the original. Thus, the graph is symmetric with respect to the x-axis.

Test for symmetry with respect to the origin.

$$y^4 = x^3 + 6$$

$$(-y)^4 = (-x)^3 + 6$$

$$y^4 = -x^3 + 6$$

The resulting equation is not equivalent to the original. Thus, the graph is not symmetric with respect to the origin.

32. Test for symmetry with respect to the y-axis.

$$y^5 = x^4 + 2$$

$$y^5 = (-x)^4 + 2$$

$$y^5 = x^4 + 2$$

The resulting equation is equivalent to the original. Thus, the graph is symmetric with respect to the y-axis.

Test for symmetry with respect to the x-axis.

$$y^5 = x^4 + 2$$

$$(-y)^5 = x^4 + 2$$

$$-y^5 = x^4 + 2$$

$$y^5 = -x^4 - 2$$

The resulting equation is not equivalent to the original. Thus, the graph is not symmetric with respect to the x-axis.

Test for symmetry with respect to the origin.

$$y^4 = x^3 + 6$$

$$(-y)^4 = (-x)^3 + 6$$

$$y^4 = -x^3 + 6$$

The resulting equation is not equivalent to the original. Thus, the graph is not symmetric with respect to the origin.

33. The graph is symmetric with respect to the y-axis. The function is even.
34. The graph is symmetric with respect to the origin. The function is odd.
35. The graph is symmetric with respect to the origin. The function is odd.
36. The graph is not symmetric with respect to the y-axis or the origin. The function is neither even nor odd.
37. $f(x) = x^3 + x$
 $f(-x) = (-x)^3 + (-x)$
 $f(-x) = -x^3 - x = -(x^3 + x)$
 $f(-x) = -f(x)$, odd function

38. $f(x) = x^3 - x$
 $f(-x) = (-x)^3 - (-x)$
 $f(-x) = -x^3 + x = -(x^3 - x)$
 $f(-x) = -f(x)$, odd function

39. $g(x) = x^2 + x$
 $g(-x) = (-x)^2 + (-x)$
 $g(-x) = x^2 - x$, neither

40. $g(x) = x^2 - x$
 $g(-x) = (-x)^2 - (-x)$
 $g(-x) = x^2 + x$, neither

41. $h(x) = x^2 - x^4$
 $h(-x) = (-x)^2 - (-x)^4$
 $h(-x) = x^2 - x^4$
 $h(-x) = h(x)$, even function

42. $h(x) = 2x^2 + x^4$
 $h(-x) = 2(-x)^2 + (-x)^4$
 $h(-x) = 2x^2 + x^4$
 $h(-x) = h(x)$, even function

43. $f(x) = x^2 - x^4 + 1$
 $f(-x) = (-x)^2 - (-x)^4 + 1$
 $f(-x) = x^2 - x^4 + 1$
 $f(-x) = f(x)$, even function

44. $f(x) = 2x^2 + x^4 + 1$
 $f(-x) = 2(-x)^2 + (-x)^4 + 1$
 $f(-x) = 2x^2 + x^4 + 1$
 $f(-x) = f(x)$, even function

45. $f(x) = \frac{1}{5}x^6 - 3x^2$
 $f(-x) = \frac{1}{5}(-x)^6 - 3(-x)^2$
 $f(-x) = \frac{1}{5}x^6 - 3x^2$
 $f(-x) = f(x)$, even function

46. $f(x) = 2x^3 - 6x^5$
 $f(-x) = 2(-x)^3 - 6(-x)^5$
 $f(-x) = -2x^3 + 6x^5$
 $f(-x) = -(2x^3 - 6x^5)$
 $f(-x) = -f(x)$, odd function

47. $f(x) = x\sqrt{1-x^2}$
 $f(-x) = -x\sqrt{1-(-x)^2}$
 $f(-x) = -x\sqrt{1-x^2}$
 $= -(x\sqrt{1-x^2})$
 $f(-x) = -f(x)$, odd function

48. $f(x) = x^2\sqrt{1-x^2}$
 $f(-x) = (-x)^2\sqrt{1-(-x)^2}$
 $f(-x) = x^2\sqrt{1-x^2}$
 $f(-x) = f(x)$, even function

49. a. domain: $(-\infty, \infty)$
 b. range: $[-4, \infty)$
 c. x -intercepts: 1, 7
 d. y -intercept: 4
 e. $(4, \infty)$
 f. $(0, 4)$
 g. $(-\infty, 0)$
 h. $x = 4$
 i. $y = -4$
 j. $f(-3) = 4$
 k. $f(2) = -2$ and $f(6) = -2$
 l. neither ; $f(-x) \neq x$, $f(-x) \neq -x$

50. a. domain: $(-\infty, \infty)$

- d. y -intercept: 1
 e. $(-\infty, -2)$ or $(0, 3)$
 f. $(-2, 0)$ or $(3, \infty)$
 g. $(-\infty, -4]$ or $[4, \infty)$
 h. $x = -2$ and $x = 3$
 i. $f(-2) = 4$ and $f(3) = 2$
 j. $f(-2) = 4$
 k. $x = -4$ and $x = 4$
 l. neither ; $f(-x) \neq x$, $f(-x) \neq -x$

51. a. domain: $(-\infty, 3]$

- b. range: $(-\infty, 4]$
 c. x -intercepts: $-3, 3$
 d. $f(0) = 3$
 e. $(-\infty, 1)$
 f. $(1, 3)$
 g. $(-\infty, -3]$
 h. $f(1) = 4$
 i. $x = 1$
 j. positive; $f(-1) = +2$

52. a. domain: $(-\infty, 6]$

- b. range: $(-\infty, 1]$
 c. zeros of f : $-3, 3$
 d. $f(0) = 1$

b. range: $(-\infty, 4]$

c. x -intercepts: $-4, 4$

e. $(-\infty, -2)$

f. $(2, 6)$

g. $(-2, 2)$

- h. $(-3, 3)$
- i. $x = -5$ and $x = 5$
- j. negative; $f(4) = -1$
- k. neither
- l. no; $f(2)$ is not greater than the function values to the immediate left.

53. a. $f(-2) = 3(-2) + 5 = -1$

b. $f(0) = 4(0) + 7 = 7$

c. $f(3) = 4(3) + 7 = 19$

54. a. $f(-3) = 6(-3) - 1 = -19$

b. $f(0) = 7(0) + 3 = 3$

c. $f(4) = 7(4) + 3 = 31$

55. a. $g(0) = 0 + 3 = 3$

b. $g(-6) = -(-6 + 3) = -(-3) = 3$

c. $g(-3) = -3 + 3 = 0$

56. a. $g(0) = 0 + 5 = 5$

b. $g(-6) = -(-6 + 5) = -(-1) = 1$

c. $g(-5) = -5 + 5 = 0$

57. a. $h(5) = \frac{5^2 - 9}{5 - 3} = \frac{25 - 9}{2} = \frac{16}{2} = 8$

b. $h(0) = \frac{0^2 - 9}{0 - 3} = \frac{-9}{-3} = 3$

c. $h(3) = 6$

58. a. $h(7) = \frac{7^2 - 25}{7 - 5} = \frac{49 - 25}{2} = \frac{24}{2} = 12$

b. $h(0) = \frac{0^2 - 25}{0 - 5} = \frac{-25}{-5} = 5$

c. $h(5) = 10$

59. a.

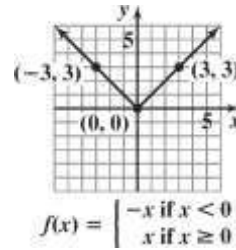

b. range: $[0, \infty)$

60. a.

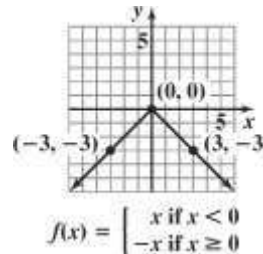

b. range: $(-\infty, 0]$

61. a.

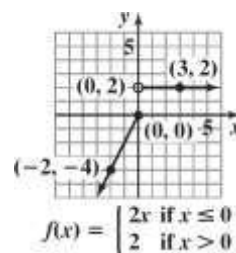

b. range: $(-\infty, 0] \cup \{2\}$

62. a.

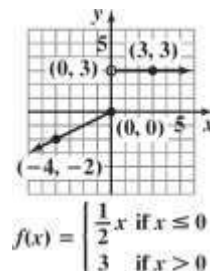

b. range: $(-\infty, 0] \cup \{3\}$

63. a.

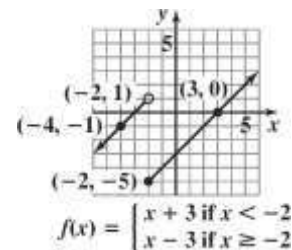

b. range: $(-\infty, \infty)$

64. a.

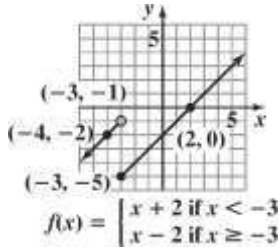

b. range: $(-\infty, \infty)$

65. a.

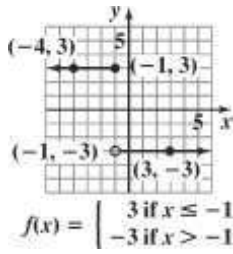

b. range: $\{-3, 3\}$

66. a.

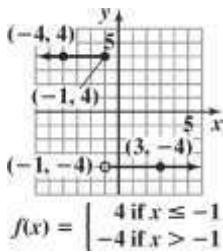

b. range: $\{-4, 4\}$

67. a.

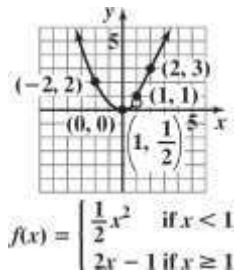

b. range: $[0, \infty)$

68. a.

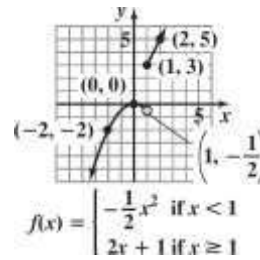

b. range: $(-\infty, 0] \cup [3, \infty)$

69. a.

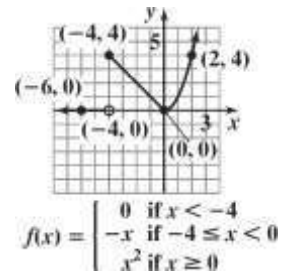

b. range: $[0, \infty)$

70. a.

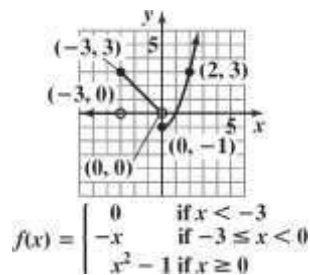

b. range: $[-1, \infty)$

71.
$$\begin{aligned} & \frac{f(x+h) - f(x)}{h} \\ &= \frac{4(x+h) - 4x}{h} \\ &= \frac{4x + 4h - 4x}{h} \\ &= \frac{4h}{h} \\ &= 4 \end{aligned}$$

$$\begin{aligned}
 72. \quad & \frac{f(x+h)-f(x)}{h} \\
 &= \frac{7(x+h)-7x}{h} \\
 &= \frac{7x+7h-7x}{h} \\
 &= \frac{7h}{h} \\
 &= 7
 \end{aligned}$$

$$\begin{aligned}
 73. \quad & \frac{f(x+h)-f(x)}{h} \\
 &= \frac{3(x+h)+7-(3x+7)}{h} \\
 &= \frac{3x+3h+7-3x-7}{h} \\
 &= \frac{3h}{h} \\
 &= 3
 \end{aligned}$$

$$\begin{aligned}
 74. \quad & \frac{f(x+h)-f(x)}{h} \\
 &= \frac{6(x+h)+1-(6x+1)}{h} \\
 &= \frac{6x+6h+1-6x-1}{h} \\
 &= \frac{6h}{h} \\
 &= 6
 \end{aligned}$$

$$\begin{aligned}
 75. \quad & \frac{f(x+h)-f(x)}{(x+h)^2-x^2} \\
 &= \frac{h}{x^2+2xh+h^2-x^2} \\
 &= \frac{2xh+h^2}{h} \\
 &= \frac{h(2x+h)}{h} \\
 &= 2x+h
 \end{aligned}$$

$$\begin{aligned}
 76. \quad & \frac{f(x+h)-f(x)}{h} \\
 &= \frac{2(x+h)^2-2x^2}{h} \\
 &= \frac{2(x^2+2xh+h^2)-2x^2}{h} \\
 &= \frac{2x^2+4xh+2h^2-2x^2}{h} \\
 &= \frac{4xh+2h^2}{h} \\
 &= \frac{h(4x+2h)}{h} \\
 &= 4x+2h
 \end{aligned}$$

$$\begin{aligned}
 & \frac{f(x+h)-f(x)}{h} \\
 77. \quad & \frac{h}{(x+h)^2-4(x+h)+3-(x^2-4x+3)} \\
 &= \frac{x^2+2xh+h^2-4x-4h+3-x^2+4x-3}{h} \\
 &= \frac{2xh+h^2-4h}{h} \\
 &= \frac{h(2x+h-4)}{h} \\
 &= 2x+h-4
 \end{aligned}$$

$$\begin{aligned}
 78. \quad & \frac{f(x+h)-f(x)}{h} \\
 &= \frac{(x+h)^2-5(x+h)+8-(x^2-5x+8)}{h} \\
 &= \frac{x^2+2xh+h^2-5x-5h+8-x^2+5x-8}{h} \\
 &= \frac{2xh+h^2-5h}{h} \\
 &= \frac{h(2x+h-5)}{h} \\
 &= 2x+h-5
 \end{aligned}$$

$$\begin{aligned}
 79. \quad & \frac{f(x+h) - f(x)}{h} \\
 &= \frac{2(x+h)^2 + (x+h) - 1 - (2x^2 + x - 1)}{h} \\
 &= \frac{2x^2 + 4xh + 2h^2 + x + h - 1 - 2x^2 - x + 1}{h} \\
 &= \frac{4xh + 2h^2 + h}{h} \\
 &= \frac{h(4x + 2h + 1)}{h} \\
 &= 4x + 2h + 1
 \end{aligned}$$

$$\begin{aligned}
 80. \quad & \frac{f(x+h) - f(x)}{h} \\
 &= \frac{3(x+h)^2 + (x+h) + 5 - (3x^2 + x + 5)}{h} \\
 &= \frac{3x^2 + 6xh + 3h^2 + x + h + 5 - 3x^2 - x - 5}{h} \\
 &= \frac{6xh + 3h^2 + h}{h} \\
 &= \frac{h(6x + 3h + 1)}{h} \\
 &= 6x + 3h + 1
 \end{aligned}$$

$$\begin{aligned}
 81. \quad & \frac{f(x+h) - f(x)}{h} \\
 &= \frac{-(x+h)^2 + 2(x+h) + 4 - (-x^2 + 2x + 4)}{h} \\
 &= \frac{-x^2 - 2xh - h^2 + 2x + 2h + 4 + x^2 - 2x - 4}{h} \\
 &= \frac{-2xh - h^2 + 2h}{h} \\
 &= \frac{h(-2x - h + 2)}{h} \\
 &= -2x - h + 2
 \end{aligned}$$

$$\begin{aligned}
 82. \quad & \frac{f(x+h) - f(x)}{h} \\
 &= \frac{-(x+h)^2 - 3(x+h) + 1 - (-x^2 - 3x + 1)}{h} \\
 &= \frac{-x^2 - 2xh - h^2 - 3x - 3h + 1 + x^2 + 3x - 1}{h} \\
 &= \frac{-2xh - h^2 - 3h}{h} \\
 &= \frac{h(-2x - h - 3)}{h} \\
 &= -2x - h - 3
 \end{aligned}$$

$$\begin{aligned}
 83. \quad & \frac{f(x+h) - f(x)}{h} \\
 &= \frac{-2(x+h)^2 + 5(x+h) + 7 - (-2x^2 + 5x + 7)}{h} \\
 &= \frac{-2x^2 - 4xh - 2h^2 + 5x + 5h + 7 + 2x^2 - 5x - 7}{h} \\
 &= \frac{-4xh - 2h^2 + 5h}{h} \\
 &= \frac{h(-4x - 2h + 5)}{h} \\
 &= -4x - 2h + 5
 \end{aligned}$$

$$\begin{aligned}
 84. \quad & \frac{f(x+h) - f(x)}{h} \\
 &= \frac{-3(x+h)^2 + 2(x+h) - 1 - (-3x^2 + 2x - 1)}{h} \\
 &= \frac{-3x^2 - 6xh - 3h^2 + 2x + 2h - 1 + 3x^2 - 2x + 1}{h} \\
 &= \frac{-6xh - 3h^2 + 2h}{h} \\
 &= \frac{h(-6x - 3h + 2)}{h} \\
 &= -6x - 3h + 2
 \end{aligned}$$

$$\begin{aligned}
 85. \quad & \frac{f(x+h)-f(x)}{h} \\
 & \frac{-2(x+h)^2 - (x+h) + 3 - (-2x^2 - x + 3)}{h} \\
 & = \frac{-2x^2 - 4xh - 2h^2 - x - h + 3 + 2x^2 + x - 3}{h} \\
 & = \frac{-4xh - 2h^2 - h}{h} \\
 & = \frac{h(-4x - 2h - 1)}{h} \\
 & = -4x - 2h - 1
 \end{aligned}$$

$$\begin{aligned}
 86. \quad & \frac{f(x+h)-f(x)}{h} \\
 & \frac{-3(x+h)^2 + (x+h) - 1 - (-3x^2 + x - 1)}{h} \\
 & = \frac{-3x^2 - 6xh - 3h^2 + x + h - 1 + 3x^2 - x + 1}{h} \\
 & = \frac{-6xh - 3h^2 + h}{h} \\
 & = \frac{h(-6x - 3h + 1)}{h} \\
 & = -6x - 3h + 1
 \end{aligned}$$

$$\frac{f(x+h)-f(x)}{h} = \frac{6-6}{0} = 0$$

$$87. \quad \frac{f(x+h)-f(x)}{h} = \frac{7-7}{h} = \frac{0}{h} = 0$$

$$88. \quad \frac{f(x+h)-f(x)}{h} = \frac{7-7}{h} = \frac{0}{h} = 0$$

$$\begin{aligned}
 89. \quad & \frac{f(x+h)-f(x)}{h} \\
 & \frac{\frac{1}{x+h} - \frac{1}{x}}{h} \\
 & = \frac{\frac{x - (x+h)}{x(x+h)}}{h} \\
 & = \frac{\frac{x - x - h}{x(x+h)}}{h} \\
 & = \frac{\frac{-h}{x(x+h)}}{h} \\
 & = \frac{-h}{h \cdot x(x+h)} \\
 & = \frac{-1}{x(x+h)}
 \end{aligned}$$

$$\begin{aligned}
 90. \quad & \frac{f(x+h)-f(x)}{h} \\
 & \frac{\frac{1}{2(x+h)} - \frac{1}{2x}}{h} \\
 & = \frac{\frac{x - (x+h)}{2x(x+h)}}{h} \\
 & = \frac{\frac{-h}{2x(x+h)}}{h} \\
 & = \frac{-h}{2x(x+h) \cdot h} \\
 & = \frac{-1}{2x(x+h)}
 \end{aligned}$$

$$\begin{aligned}
 91. \quad & \frac{f(x+h)-f(x)}{h} \\
 & \frac{\sqrt{x+h} - \sqrt{x}}{h} \\
 & = \frac{\sqrt{x+h} - \sqrt{x}}{h} \cdot \frac{\sqrt{x+h} + \sqrt{x}}{\sqrt{x+h} + \sqrt{x}} \\
 & = \frac{x+h-x}{h(\sqrt{x+h} + \sqrt{x})} \\
 & = \frac{h}{h(\sqrt{x+h} + \sqrt{x})} \\
 & = \frac{1}{\sqrt{x+h} + \sqrt{x}}
 \end{aligned}$$

$$\begin{aligned}
 92. \quad & \frac{f(x+h)-f(x)}{h} \\
 & \frac{\sqrt{x+h-1} - \sqrt{x-1}}{h} \\
 & = \frac{\sqrt{x+h-1} - \sqrt{x-1}}{h} \cdot \frac{\sqrt{x+h-1} + \sqrt{x-1}}{\sqrt{x+h-1} + \sqrt{x-1}} \\
 & = \frac{x+h-1 - (x-1)}{h(\sqrt{x+h-1} + \sqrt{x-1})} \\
 & = \frac{x+h-1-x+1}{h(\sqrt{x+h-1} + \sqrt{x-1})} \\
 & = \frac{h}{h(\sqrt{x+h-1} + \sqrt{x-1})} \\
 & = \frac{1}{\sqrt{x+h-1} + \sqrt{x-1}}
 \end{aligned}$$

$$= \frac{h}{-h} \cdot \frac{1}{1}$$

$$= \frac{x(x+h)h}{x(x+h)}$$

$$= \frac{h}{h(\sqrt{x+h-1} + \sqrt{x-1})}$$

$$= \frac{1}{\sqrt{x+h-1} + \sqrt{x-1}}$$

93. $\sqrt{f(-1.5) + f(-0.9)} - [f(\pi)]^2 + f(-3) \div f(1) \cdot f(-\pi)$
 $= \sqrt{1+0} - [-4]^2 + 2 \div (-2) \cdot 3$
 $= \sqrt{1} - 16 + (-1) \cdot 3$
 $= 1 - 16 - 3$
 $= -18$

94. $\sqrt{f(-2.5) - f(1.9)} - [f(-\pi)]^2 + f(-3) \div f(1) \cdot f(\pi)$
 $\sqrt{f(-2.5) - f(1.9)} - [f(-\pi)]^2 + f(-3) \div f(1) \cdot f(\pi)$
 $= \sqrt{2 - (-2)} - [3]^2 + 2 \div (-2) \cdot (-4)$
 $= \sqrt{4} - 9 + (-1)(-4)$
 $= 2 - 9 + 4$
 $= -3$

95. $30 + 0.30(t - 120) = 30 + 0.3t - 36 = 0.3t - 6$

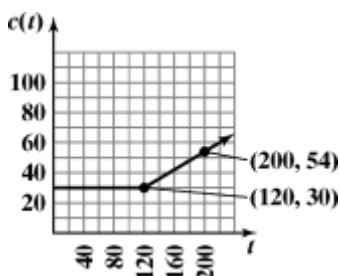

96. $40 + 0.30(t - 200) = 40 + 0.3t - 60 = 0.3t - 20$

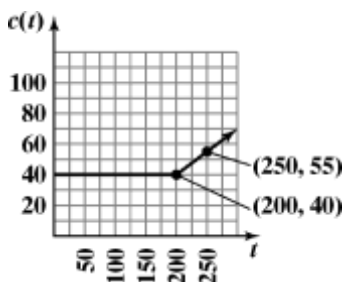

97. $C(t) = \begin{cases} 50 & \text{if } 0 \leq t \leq 400 \\ 50 + 0.30(t - 400) & \text{if } t > 400 \end{cases}$

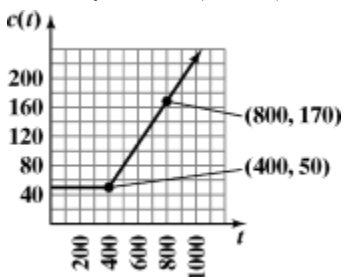

98. $C(t) = \begin{cases} 60 & \text{if } 0 \leq t \leq 450 \\ 60 + 0.35(t - 450) & \text{if } t > 450 \end{cases}$

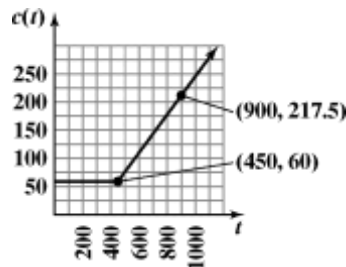

99. increasing: (25, 55); decreasing: (55, 75)

100. increasing: (25, 65); decreasing: (65, 75)

101. The percent body fat in women reaches a maximum at age 55. This maximum is 38%.

102. The percent body fat in men reaches a maximum at age 65. This maximum is 26%.

103. domain: [25, 75]; range: [34, 38]

104. domain: [25, 75]; range: [23, 26]

105. This model describes percent body fat in men.

106. This model describes percent body fat in women.

107. $T(20,000) = 850 + 0.15(20,000 - 8500)$
 $= 2575$

A single taxpayer with taxable income of \$20,000 owes \$2575.

108. $T(50,000) = 4750 + 0.25(50,000 - 34,500)$
 $= 8625$

A single taxpayer with taxable income of \$50,000 owes \$8625.

109. $42,449 + 0.33(x - 174,400)$

110. $110,016.50 + 0.35(x - (x - 379,150))$

111. $f(3) = 0.93$

The cost of mailing a first-class letter weighing 3 ounces is \$0.93.

112. $f(3.5) = 1.05$

The cost of mailing a first-class letter weighing 3.5 ounces is \$1.05.

113. The cost to mail a letter weighing 1.5 ounces is \$0.65.

114. The cost to mail a letter weighing 1.8 ounces is \$0.65.

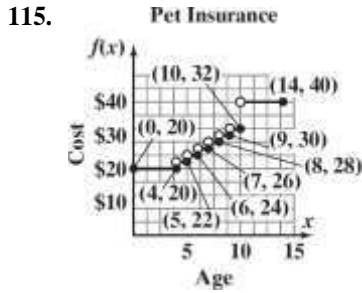

116. – 124. Answers will vary.

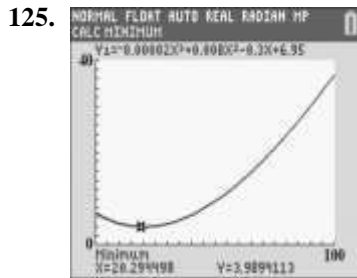

The number of doctor visits decreases during childhood and then increases as you get older. The minimum is (20.29, 3.99), which means that the minimum number of doctor visits, about 4, occurs at around age 20.

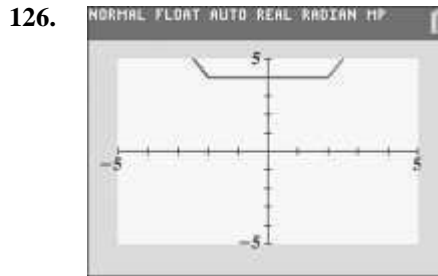

Increasing: $(-\infty, 2)$ or $(3, \infty)$
 Decreasing: $(2, 3)$

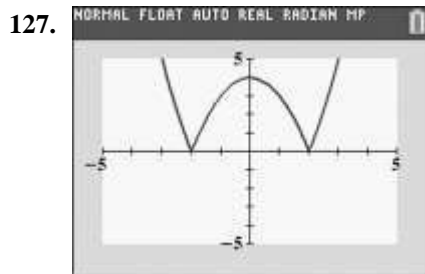

Increasing: $(-2, 0)$ or $(2, \infty)$
 Decreasing: $(-\infty, -2)$ or $(0, 2)$

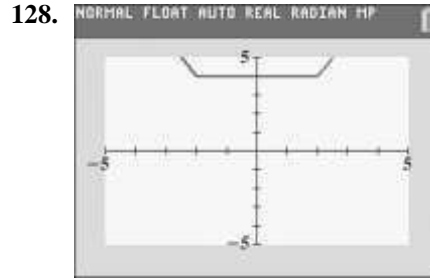

Increasing: $(2, \infty)$
 Decreasing: $(-\infty, 2)$
 Constant: $(-2, 2)$

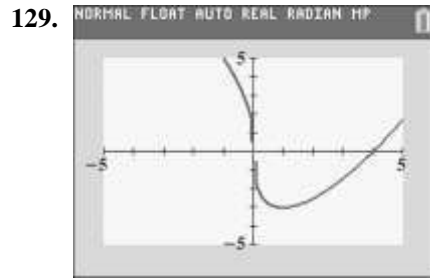

Increasing: $(1, \infty)$
 Decreasing: $(-\infty, 1)$

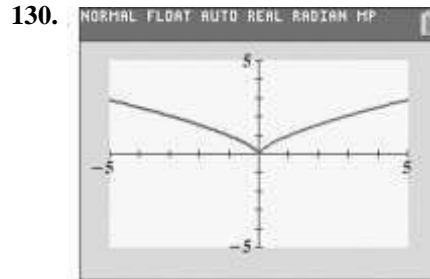

Increasing: $(0, \infty)$
 Decreasing: $(-\infty, 0)$

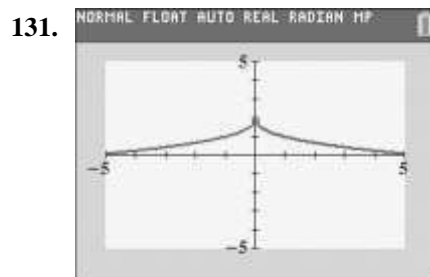

Increasing: $(-\infty, 0)$
 Decreasing: $(0, \infty)$

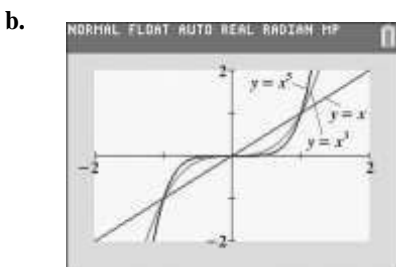
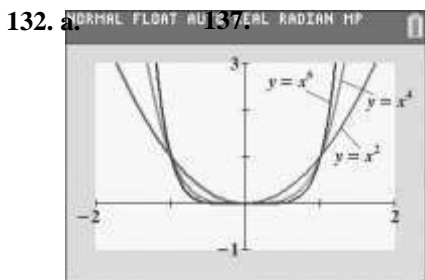

c. Increasing: $(0, \infty)$
Decreasing: $(-\infty, 0)$

d. $f(x) = x^n$ is increasing from $(-\infty, \infty)$ when n is odd.

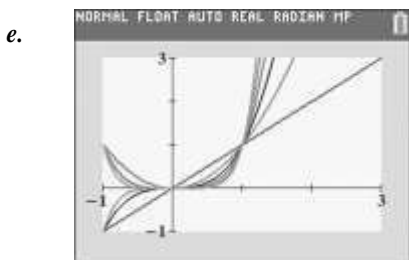

133. does not make sense; Explanations will vary.
Sample explanation: It's possible the graph is not defined at a .

134. makes sense

135. makes sense

136. makes sense

answers will vary

138. answers will vary

139. a. h is even if both f and g are even or if both f and g are odd.

f and g are both even:

$$h(-x) = \frac{f(-x)}{g(-x)} = \frac{f(x)}{g(x)} = h(x)$$

f and g are both odd:

$$h(-x) = \frac{f(-x)}{g(-x)} = \frac{-f(x)}{-g(x)} = \frac{f(x)}{g(x)} = h(x)$$

b. h is odd if f is odd and g is even or if f is even and g is odd.

f is odd and g is even:

$$h(-x) = \frac{f(-x)}{g(-x)} = \frac{-f(x)}{g(x)} = -\frac{f(x)}{g(x)} = -h(x)$$

f is even and g is odd:

$$h(-x) = \frac{f(-x)}{g(-x)} = \frac{f(x)}{-g(x)} = -\frac{f(x)}{g(x)} = -h(x)$$

140. Let x = the amount invested at 5%.

Let $80,000 - x$ = the amount invested at 7%.

$$0.05x + 0.07(80,000 - x) = 5200$$

$$0.05x + 5600 - 0.07x = 5200$$

$$-0.02x + 5600 = 5200$$

$$-0.02x = -400$$

$$x = 20,000$$

$$80,000 - x = 60,000$$

\$20,000 was invested at 5% and \$60,000 was invested at 7%.

141. $C = A + Ar$

$$C = A + Ar$$

$$C = A(1 + r)$$

$$\frac{C}{1 + r} = A$$

142. $5x^2 - 7x + 3 = 0$
 $a = 5, b = -7, c = 3$
 $x = \frac{-b \pm \sqrt{b^2 - 4ac}}{2a}$

$$x = \frac{-(-7) \pm \sqrt{(-7)^2 - 4(5)(3)}}{2(5)}$$

$$x = \frac{7 \pm \sqrt{49 - 60}}{10}$$

$$x = \frac{7 \pm \sqrt{11}}{10}$$

$$x = \frac{7 \pm i\sqrt{11}}{10}$$

$$x = \frac{7}{10} \pm i \frac{\sqrt{11}}{10}$$

The solution set is $\left\{ \frac{7}{10} + i \frac{\sqrt{11}}{10}, \frac{7}{10} - i \frac{\sqrt{11}}{10} \right\}$

143. $\frac{y_2 - y_1}{x_2 - x_1} = \frac{4 - 1}{-2 - (-3)} = \frac{3}{1}$

144. When $y = 0$:

$$4x - 3y - 6 = 0$$

$$4x - 3(0) - 6 = 0$$

$$4x - 6 = 0$$

$$4x = 6$$

$$x = \frac{3}{2}$$

The point is $\left(\frac{3}{2}, 0 \right)$

When $x = 0$:

$$4x - 3y - 6 = 0$$

$$4(0) - 3y - 6 = 0$$

$$-3y - 6 = 0$$

$$-3y = 6$$

$$y = -2$$

The point is $(0, -2)$.

145. $3x + 2y - 4 = 0$
 $2y = -3x + 4$
 $y = \frac{-3x + 4}{2}$

Section 2.3

Check Point Exercises

1. a. $m = \frac{-2 - 4}{-4 - (-3)} = \frac{-6}{-1} = 6$

b. $m = \frac{5 - (-2)}{-1 - 4} = \frac{7}{-5} = -\frac{7}{5}$

2. Point-slope form:

$$y - y_1 = m(x - x_1)$$

$$y - (-5) = 6(x - 2)$$

$$y + 5 = 6(x - 2)$$

Slope-intercept form:

$$y + 5 = 6(x - 2)$$

$$y + 5 = 6x - 12$$

$$y = 6x - 17$$

3. $m = \frac{-6 - (-1)}{-1 - (-2)} = \frac{-5}{1} = -5$,

so the slope is -5 .

Using the point $(-2, -1)$, we get the following point-slope equation:

$$y - y_1 = m(x - x_1)$$

$$y - (-1) = -5[x - (-2)]$$

$$y + 1 = -5(x + 2)$$

Using the point $(-1, -6)$, we get the following point-slope equation:

$$y - y_1 = m(x - x_1)$$

$$y - (-6) = -5[x - (-1)]$$

$$y + 6 = -5(x + 1)$$

Solve the equation for y :

$$y + 1 = -5(x + 2)$$

$$y + 1 = -5x - 10$$

$$y = -5x - 11.$$

4. The slope m is $\frac{3}{5}$ and the y -intercept is 1, so one point on the line is $(0, 1)$. We can find a second point on the line by using the slope $m = \frac{\text{Rise}}{\text{Run}}$ starting at the point $(0, 1)$, move 3 units up and 5 units to the right, to obtain the point $(5, 4)$.

or

$$y = -\frac{3}{2}x + 2$$

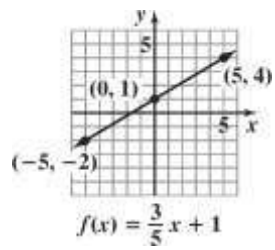

5. $y = 3$ is a horizontalline.

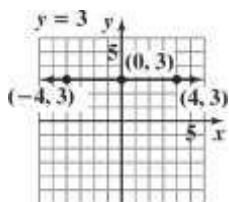

6. All ordered pairs that are solutions of $x = -3$ have a value of x that is always -3 . Any value can be used for y .

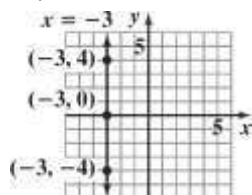

7. $3x + 6y - 12 = 0$

$$6y = -3x + 12$$

$$y = \frac{-3}{6}x + \frac{12}{6}$$

$$y = -\frac{1}{2}x + 2$$

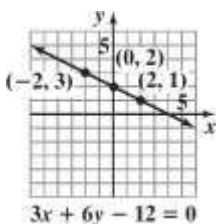

The slope is $-\frac{1}{2}$ and the y -intercept is 2.

8. Find the x -intercept:

$$3x - 2y - 6 = 0$$

$$3x - 2(0) - 6 = 0$$

$$3x - 6 = 0$$

$$3x = 6$$

$$x = 2$$

Find the y -intercept:

$$3x - 2y - 6 = 0$$

$$3(0) - 2y - 6 = 0$$

$$-2y - 6 = 0$$

$$-2y = 6$$

$$y = -3$$

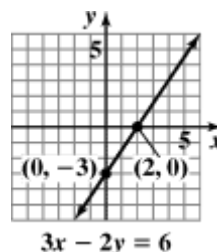

9. First find the slope.

$$m = \frac{\text{Change in } y}{\text{Change in } x} = \frac{57.64 - 57.04}{354 - 317} = \frac{0.6}{37} \approx 0.016$$

Use the point-slope form and then find slope-intercept form.

$$y - y_1 = m(x - x_1)$$

$$y - 57.04 = 0.016(x - 317)$$

$$y - 57.04 = 0.016x - 5.072$$

$$y = 0.016x + 51.968$$

$$f(x) = 0.016x + 52.0$$

Find the temperature at a concentration of 600 parts per million.

$$f(x) = 0.016x + 52.0$$

$$f(600) = 0.016(600) + 52.0$$

$$= 61.6$$

The temperature at a concentration of 600 parts per million would be 61.6°F .

Concept and Vocabulary Check 2.3

1. scatter plot; regression

2. $\frac{y_2 - y_1}{x_2 - x_1}$

3. positive

4. negative

5. zero

6. undefined

7. $y - y_1 = m(x - x_1)$

Chapter 2 Functions and Graphs

8. $y = mx + b$; slope; y-intercept

9. $(0, 3)$; 2; 5

10. horizontal

11. vertical

12. general

Exercise Set 2.3

1. $m = \frac{10-7}{8-4} = \frac{3}{4}$; rises

2. $m = \frac{4-1}{3-2} = \frac{3}{1} = 3$; rises

3. $m = \frac{2-1}{2-(-2)} = \frac{1}{4}$; rises

4. $m = \frac{4-3}{2-(-1)} = \frac{1}{3}$; rises

5. $m = \frac{2-(-2)}{3-4} = \frac{0}{-1} = 0$; horizontal

6. $m = \frac{-1-(-1)}{3-4} = \frac{0}{-1} = 0$; horizontal

7. $m = \frac{-1-4}{-1-(-2)} = \frac{-5}{1} = -5$; falls

8. $m = \frac{-2-(-4)}{4-6} = \frac{2}{-2} = -1$; falls

9. $m = \frac{-2-3}{5-5} = \frac{-5}{0}$ undefined; vertical

10. $m = \frac{5-(-4)}{3-3} = \frac{9}{0}$ undefined; vertical

11. $m = 2, x_1 = 3, y_1 = 5$;

13. $m = 6, x_1 = -2, y_1 = 5$;
point-slope form: $y - 5 = 6(x + 2)$;
slope-intercept form: $y - 5 = 6x + 12$
 $y = 6x + 17$

14. point-slope form: $y + 1 = 8(x - 4)$;
 $m = 8, x_1 = 4, y_1 = -1$;
slope-intercept form: $y = 8x - 33$

15. $m = -3, x_1 = -2, y_1 = -3$;
point-slope form: $y + 3 = -3(x + 2)$;
slope-intercept form: $y + 3 = -3x - 6$
 $y = -3x - 9$

16. point-slope form: $y + 2 = -5(x + 4)$;
 $m = -5, x_1 = -4, y_1 = -2$;
slope-intercept form: $y = -5x - 22$

17. $m = -4, x_1 = -4, y_1 = 0$;
point-slope form: $y - 0 = -4(x + 4)$;
slope-intercept form: $y = -4(x + 4)$
 $y = -4x - 16$

18. point-slope form: $y + 3 = -2(x - 0)$
 $m = -2, x_1 = 0, y_1 = -3$;
slope-intercept form: $y = -2x - 3$

19. $m = -1, x_1 = 2, y_1 = -2$;
point-slope form: $y + 2 = -1(x - 2)$;
slope-intercept form: $y + 2 = -x - \frac{1}{2}$

20. point-slope form: $y + \frac{1}{4} = -1(x + 4)$;
 $m = -1, x_1 = -4, y_1 = -\frac{1}{4}$;
slope-intercept form: $y = -x - \frac{17}{4}$

point-slope form: $y - 5 = 2(x - 3)$;

slope-intercept form: $y - \frac{1}{5}, x = 0, y = 0;$ 4

form: $y - \frac{1}{5}, x = 0, y = 0;$
 $5 = 2x - 6$

21.

$m =$

$y = 2x - 1$

12. point-slope form: $y - 3 = 4(x - 1);$

$m = 4, x_1 = 1, y_1 = 3;$

slope-intercept form: $y = 4x - 1$

point-slope form: $y - 0 = \frac{1}{2}(x - 0);$

slope-intercept form: $y = \frac{1}{2}x$

22. point-slope form: $y - 0 = \frac{1}{3}(x - 0)$;
 $m = \frac{1}{3}, x = 0, y = 0$;

slope-intercept form: $y = \frac{1}{3}x$

23. $m = -\frac{2}{3}, x = 6, y = -2$;

point-slope form: $y + 2 = -\frac{2}{3}(x - 6)$;

slope-intercept form: $y + 2 = -\frac{2}{3}x + 4$
 $y = -\frac{2}{3}x + 2$

24. point-slope form: $y + 4 = -\frac{3}{5}(x - 10)$;

$m = -\frac{3}{5}, x_1 = 10, y_1 = -4$;

slope-intercept form: $y = -\frac{3}{5}x + 2$

25. $m = \frac{10 - 2}{5 - 1} = \frac{8}{4} = 2$;

point-slope form: $y - 2 = 2(x - 1)$ using
 $(x_1, y_1) = (1, 2)$, or $y - 10 = 2(x - 5)$ using
 $(x_1, y_1) = (5, 10)$;

slope-intercept form: $y - 2 = 2x - 2$ or

$y - 10 = 2x - 10$,
 $y = 2x$

26. $m = \frac{15 - 5}{8 - 3} = \frac{10}{5} = 2$;

point-slope form: $y - 5 = 2(x - 3)$ using
 $(x_1, y_1) = (3, 5)$, or $y - 15 = 2(x - 8)$ using

$(x_1, y_1) = (8, 15)$;

slope-intercept form: $y = 2x - 1$

27. $m = \frac{3 - 0}{0 - (-3)} = \frac{3}{3} = 1$;

$0 - (-3) = 3$

28. $m = \frac{2 - 0}{0 - (-2)} = \frac{2}{2} = 1$;

point-slope form: $y - 0 = 1(x + 2)$ using

$(x_1, y_1) = (-2, 0)$, or $y - 2 = 1(x - 0)$ using

$(x_1, y_1) = (0, 2)$;

slope-intercept form: $y = x + 2$

29. $m = \frac{4 - (-1)}{2 - (-3)} = \frac{5}{5} = 1$;

point-slope form: $y + 1 = 1(x + 3)$ using

$(x_1, y_1) = (-3, -1)$, or $y - 4 = 1(x - 2)$ using

$(x_1, y_1) = (2, 4)$; slope-intercept form:

$y + 1 = x + 3$ or

$y - 4 = x - 2$

$y = x + 2$

30. $m = \frac{-1 - (-4)}{1 - (-2)} = \frac{3}{3} = 1$;

point-slope form: $y + 4 = 1(x + 2)$ using

$(x, y) = (-2, -4)$, or $y + 1 = 1(x - 1)$ using

$(x_1, y_1) = (1, -1)$

slope-intercept form: $y = x - 2$

31. $m = \frac{6 - (-2)}{3 - (-3)} = \frac{8}{6} = \frac{4}{3}$;

point-slope form: $y + 2 = \frac{4}{3}(x + 3)$ using

$(x, y) = (-3, -2)$, or $y - 6 = \frac{4}{3}(x - 3)$ using

$(x_1, y_1) = (3, 6)$;

slope-intercept form: $y + 2 = \frac{4}{3}x + 4$ or
 $y - 6 = \frac{4}{3}x - 4$,

$y = \frac{4}{3}x + 2$

32. $m = \frac{-2 - 6}{3 - (-3)} = \frac{-8}{6} = -\frac{4}{3}$;

point-slope form: $y - 0 = 1(x + 3)$ using

$(x_1, y_1) = (-3, 0)$, or $y - 3 = 1(x - 0)$ using

$(x_1, y_1) = (0, 3)$; slope-intercept form: $y = x + 3$
1 1

point-slope form: $y - 6 = -\frac{4}{3}(x + 3)$ using

$(x_1, y_1) = (-3, 6)$, or $y + 2 = -\frac{4}{3}(x - 3)$ using
3

$(x_1, y_1) = (3, -2)$;

slope-intercept form: $y = -\frac{4}{3}x + 2$

33. $m = \frac{-1 - (-1)}{4 - (-3)} = \frac{0}{7} = 0$;

point-slope form: $y + 1 = 0(x + 3)$ using $(x_1, y_1) = (-3, -1)$, or $y + 1 = 0(x - 4)$ using $(x_1, y_1) = (4, -1)$;

slope-intercept form: $y + 1 = 0$, so

$$y = -1$$

34. $m = \frac{-5 - (-5)}{6 - (-2)} = \frac{0}{8} = 0$;

point-slope form: $y + 5 = 0(x + 2)$ using $(x_1, y_1) = (-2, -5)$, or $y + 5 = 0(x - 6)$ using $(x_1, y_1) = (6, -5)$;

slope-intercept form: $y + 5 = 0$, so

$$y = -5$$

35. $m = \frac{0 - 4}{-2 - 2} = \frac{-4}{-4} = 1$;

$$-2 - 2 = -4$$

point-slope form: $y - 4 = 1(x - 2)$ using $(x_1, y_1) = (2, 4)$, or $y - 0 = 1(x + 2)$ using $(x_1, y_1) = (-2, 0)$;

slope-intercept form: $y - 9 = x - 2$, or

$$y = x + 2$$

36. $m = \frac{0 - (-3)}{-1 - 1} = \frac{3}{-2} = -\frac{3}{2}$

point-slope form: $y + 3 = -\frac{3}{2}(x - 1)$ using $(x, y) = (1, -3)$, or $y - 0 = -\frac{3}{2}(x + 1)$ using

$$(x_1, y_1) = (-1, 0)$$

slope-intercept form: $y + 3 = -\frac{3}{2}x + \frac{3}{2}$, or

$$y = -\frac{3}{2}x - \frac{3}{2}$$

37. $m = \frac{4 - 0}{0 - (-\frac{1}{2})} = \frac{4}{\frac{1}{2}} = 8$;

point-slope form: $y - 4 = 8(x - 0)$ using $(x_1, y_1) = (0, 4)$, or $y - 0 = 8(x + \frac{1}{2})$ using $(x_1, y_1) = (-\frac{1}{2}, 0)$; or $y - 0 = 8(x + \frac{1}{2})$

slope-intercept form: $y = 8x + 4$

38. $m = \frac{-2 - 0}{0 - 4} = \frac{-2}{-4} = \frac{1}{2}$;

point-slope form: $y - 0 = \frac{1}{2}(x - 4)$ using

$$(x_1, y_1) = (4, 0),$$

or $y + 2 = \frac{1}{2}(x - 0)$ using $(x, y) = (0, -2)$;

$$\frac{1}{2}x - 2$$

slope-intercept form: $y = \frac{1}{2}x - 2$

39. $m = 2; b = 1$

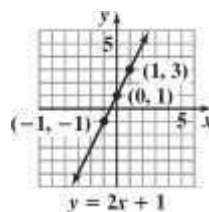

40. $m = 3; b = 2$

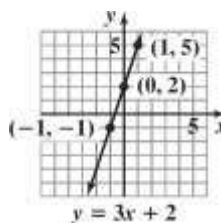

41. $m = -2; b = 1$

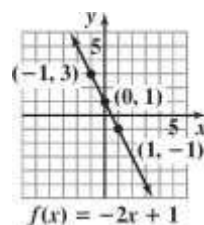

42. $m = -3; b = 2$

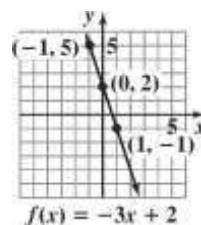

43. $m = \frac{3}{4}; b = -2$

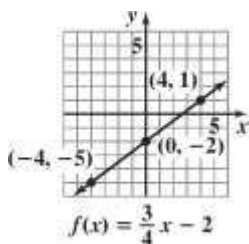

48. $m = -\frac{1}{3}; b = 0$

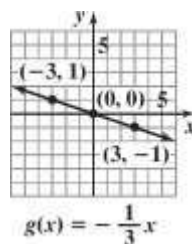

44. $m = \frac{3}{4}; b = -3$

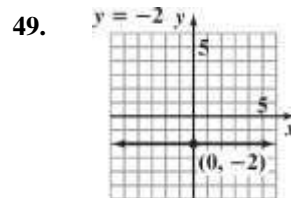
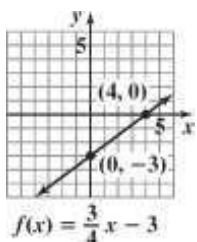

45. $m = -\frac{3}{5}; b = 7$

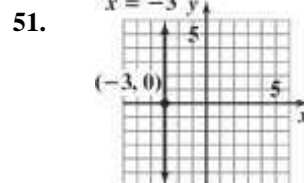
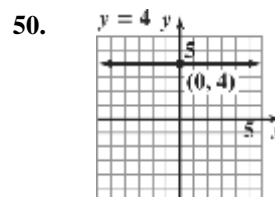
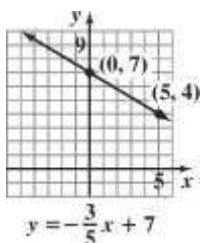

46. $m = -\frac{2}{5}; b = 6$

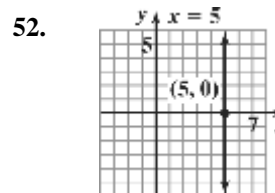
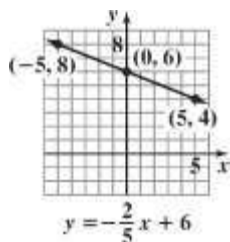

47. $m = -\frac{1}{2}; b = 0$

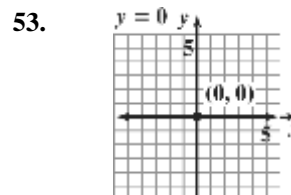
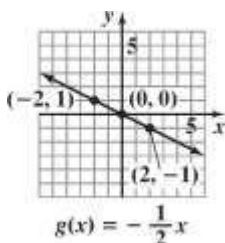

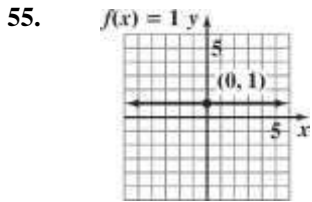
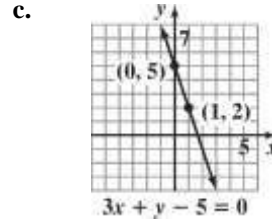
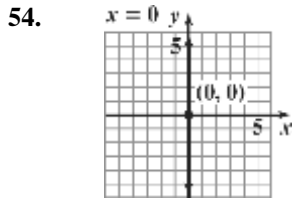

60. a. $4x + y - 6 = 0$
 $y - 6 = -4x$
 $y = -4x + 6$

b. $m = -4; b = 6$

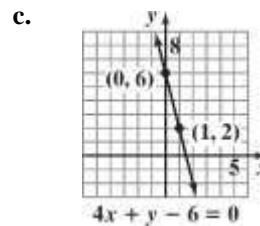
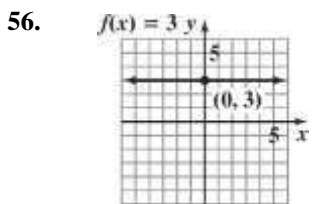

57. $3x - 18 = 0$
 $3x = 18$
 $x = 6$

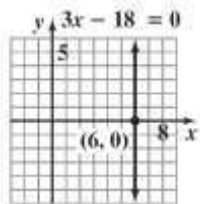

61. a. $2x + 3y - 18 = 0$
 $2x - 18 = -3y$
 $-3y = 2x - 18$
 $y = \frac{2}{-3}x - \frac{18}{-3}$
 $y = -\frac{2}{3}x + 6$

b. $m = -\frac{2}{3}; b = 6$

58. $3x + 12 = 0$
 $3x = -12$
 $x = -4$

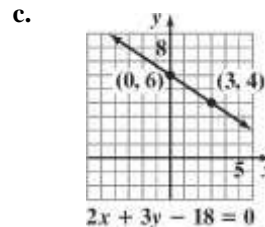
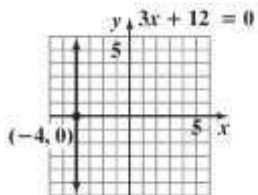

59. a. $3x + y - 5 = 0$
 $y - 5 = -3x$
 $y = -3x + 5$

b. $m = -3; b = 5$

62. a. $4x + 6y + 12 = 0$
 $4x + 12 = -6y$
 $-6y = 4x + 12$
 $y = \frac{4}{-6}x + \frac{12}{-6}$
 $y = -\frac{2}{3}x - 2$

b. $m = -\frac{2}{3}; b = -2$

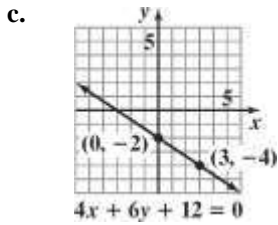

63. a. $8x - 4y - 12 = 0$
 $8x - 12 = 4y$
 $4y = 8x - 12$
 $y = \frac{8}{4}x - \frac{12}{4}$
 $y = 2x - 3$

b. $m = 2; b = -3$

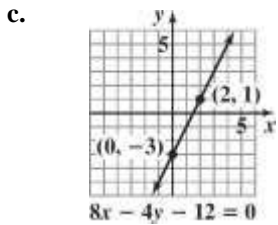

64. a. $6x - 5y - 20 = 0$
 $6x - 20 = 5y$
 $5y = 6x - 20$
 $y = \frac{6}{5}x - \frac{20}{5}$
 $y = \frac{6}{5}x - 4$
 6

b. $m = \frac{3}{5}; b = -4$

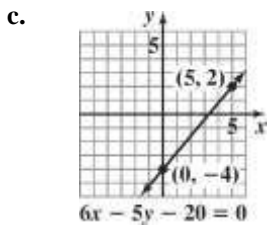

65. a. $3y - 9 = 0$
 $3y = 9$
 $y = 3$

b. $m = 0; b = 3$

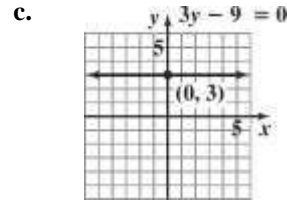

66. a. $4y + 28 = 0$
 $4y = -28$
 $y = -7$

b. $m = 0; b = -7$

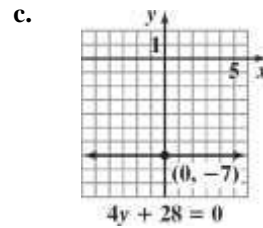

67. Find the x-intercept:
 $6x - 2y - 12 = 0$
 $6x - 2(0) - 12 = 0$
 $6x - 12 = 0$
 $6x = 12$
 $x = 2$

Find the y-intercept:
 $6x - 2y - 12 = 0$
 $6(0) - 2y - 12 = 0$
 $-2y - 12 = 0$
 $-2y = 12$
 $y = -6$

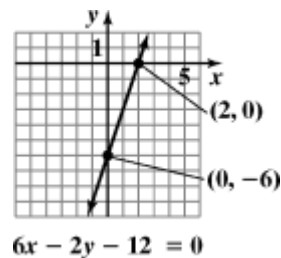

68. Find the x -intercept:

$$6x - 9y - 18 = 0$$

$$6x - 9(0) - 18 = 0$$

$$6x - 18 = 0$$

$$6x = 18$$

$$x = 3$$

- Find the y -intercept:

$$6x - 9y - 18 = 0$$

$$6(0) - 9y - 18 = 0$$

$$-9y - 18 = 0$$

$$-9y = 18$$

$$y = -2$$

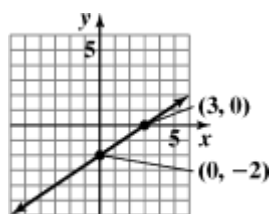

$$6x - 9y - 18 = 0$$

69. Find the x -intercept:

$$2x + 3y + 6 = 0$$

$$2x + 3(0) + 6 = 0$$

$$2x + 6 = 0$$

$$2x = -6$$

$$x = -3$$

- Find the y -intercept:

$$2x + 3y + 6 = 0$$

$$2(0) + 3y + 6 = 0$$

$$3y + 6 = 0$$

$$3y = -6$$

$$y = -2$$

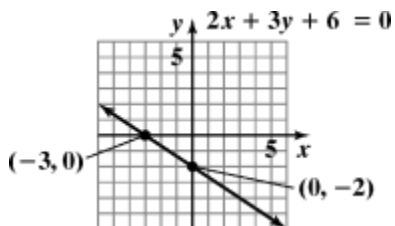

70. Find the x -intercept:

$$3x + 5y + 15 = 0$$

$$3x + 5(0) + 15 = 0$$

$$3x + 15 = 0$$

$$3x = -15$$

$$x = -5$$

- Find the y -intercept:

$$3x + 5y + 15 = 0$$

$$3(0) + 5y + 15 = 0$$

$$5y + 15 = 0$$

$$5y = -15$$

$$y = -3$$

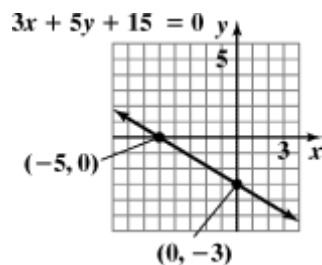

71. Find the x -intercept:

$$8x - 2y + 12 = 0$$

$$8x - 2(0) + 12 = 0$$

$$8x + 12 = 0$$

$$8x = -12$$

$$\frac{8x}{8} = \frac{-12}{8}$$

$$x = \frac{-3}{2}$$

- Find the y -intercept:

$$8x - 2y + 12 = 0$$

$$8(0) - 2y + 12 = 0$$

$$-2y + 12 = 0$$

$$-2y = -12$$

$$y = -6$$

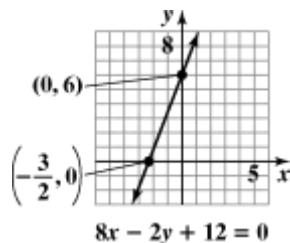

72. Find the x -intercept:

$$6x - 3y + 15 = 0$$

$$6x - 3(0) + 15 = 0$$

$$6x + 15 = 0$$

$$6x = -15$$

$$\frac{6x}{6} = \frac{-15}{6}$$

$$x = -\frac{5}{2}$$

Find the y -intercept:

$$6x - 3y + 15 = 0$$

$$6(0) - 3y + 15 = 0$$

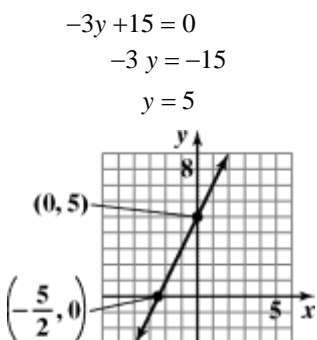

$$6x + 3y + 15 = 0$$

73. $m = \frac{0 - a}{b - 0} = \frac{-a}{b} = -\frac{a}{b}$

Since a and b are both positive, $-\frac{a}{b}$ is negative. Therefore, the line falls.

74. $m = \frac{-b - 0}{0 - (-a)} = \frac{-b}{a} = -\frac{b}{a}$

Since a and b are both positive, $-\frac{b}{a}$ is negative. Therefore, the line falls.

75. $m = \frac{(b+c) - b}{a - a} = \frac{c}{0}$

The slope is undefined.
The line is vertical.

76. $m = \frac{(a+c) - c}{a - (a-b)} = \frac{a}{b}$

Since a and b are both positive, $\frac{a}{b}$ is positive.
Therefore, the line rises.

77. $Ax + By = C$
 $By = -Ax + C$
 $y = -\frac{A}{B}x + \frac{C}{B}$

The slope is $-\frac{A}{B}$ and the y -intercept is $\frac{C}{B}$.

78. $Ax = By - C$
 $Ax + C = By$
 $\frac{A}{B}x + \frac{C}{B} = y$

The slope is $\frac{A}{B}$ and the y -intercept is $\frac{C}{B}$.

79. $-3 = \frac{4 - y}{1 - 3}$
 $-3 = \frac{4 - y}{-2}$
 $6 = 4 - y$
 $2 = -y$
 $-2 = y$

80. $\frac{1}{3} = \frac{-4 - y}{4 - (-2)}$
 $\frac{1}{3} = \frac{-4 - y}{4 + 2}$
 $\frac{1}{3} = \frac{-4 - y}{6}$
 $6 = 3(-4 - y)$
 $6 = -12 - 3y$
 $18 = -3y$
 $-6 = y$

81. $3x - 4f(x) = 6$
 $-4f(x) = -3x + 6$

$$f(x) = \frac{3}{4}x - \frac{3}{2}$$

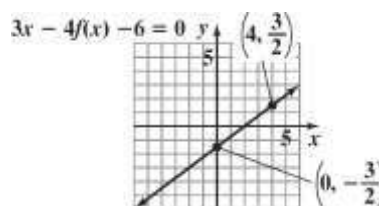

82. $6x - 5f(x) = 20$
 $-5f(x) = -6x + 20$
 $f(x) = \frac{6}{5}x - 4$

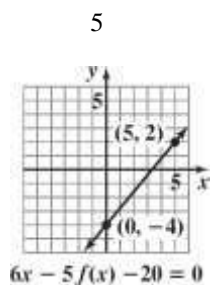

83. Using the slope-intercept form for the equation of a line:

$-1 = -2(3) + b$
 $-1 = -6 + b$
 $5 = b$

84. $-6 = -\frac{3}{2}(2) + b$
 $-6 = -3 + b$
 $-3 = b$

85. m_1, m_3, m_2, m_4

86. b_2, b_1, b_4, b_3

87. a. First, find the slope using (20, 38.9) and (30, 47.8).

$$m = \frac{47.8 - 38.9}{30 - 20} = \frac{8.9}{10} = 0.89$$

Then use the slope and one of the points to write the equation in point-slope form.

$y - y_1 = m(x - x_1)$
 $y - 47.8 = 0.89(x - 30)$

or

$y - 38.9 = 0.89(x - 20)$

b. $y - 47.8 = 0.89(x - 30)$
 $y - 47.8 = 0.89x - 26.7$
 $y = 0.89x + 21.1$
 $f(x) = 0.89x + 21.1$

c. $f(40) = 0.89(40) + 21.1 = 56.7$

The linear function predicts the percentage of never married American females, ages 25 – 29, to be 56.7% in 2020.

88. a. First, find the slope using (20, 51.7) and (30, 62.6).

$$m = \frac{51.7 - 62.6}{20 - 30} = \frac{-10.9}{-10} = 1.09$$

$20 - 30 = -10$

Then use the slope and one of the points to write the equation in point-slope form.

$y - y_1 = m(x - x_1)$
 $y - 62.6 = 1.09(x - 30)$

or

$y - 51.7 = 1.09(x - 20)$

b. $y - 62.6 = 1.09(x - 30)$

$y - 62.6 = 1.09x - 32.7$

$y = 1.09x + 29.9$

$f(x) = 1.09x + 29.9$

c. $f(35) = 1.09(35) + 29.9 = 68.05$

The linear function predicts the percentage of never married American males, ages 25 – 29, to be 68.05% in 2015.

89. a. Life Expectancy for United States Males, by Year of Birth

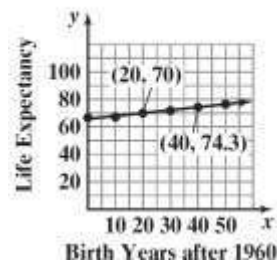

b. $m = \frac{\text{Change in } y}{\text{Change in } x} = \frac{74.3 - 70.0}{40 - 20} = 0.215$

$y - y_1 = m(x - x_1)$
 $y - 70.0 = 0.215(x - 20)$
 $y - 70.0 = 0.215x - 4.3$
 $y = 0.215x + 65.7$
 $E(x) = 0.215x + 65.7$

c. $E(x) = 0.215x + 65.7$
 $E(60) = 0.215(60) + 65.7$
 $= 78.6$

The life expectancy of American men born in 2020 is expected to be 78.6.

90. a. Life Expectancy for United States Females, by Year of Birth

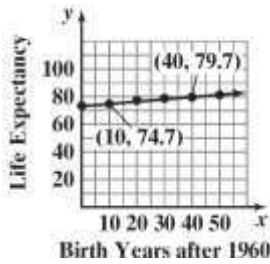

b. $m = \frac{\text{Change in } y}{\text{Change in } x} = \frac{79.7 - 74.7}{40 - 10} \approx 0.17$
 $y - y_1 = m(x - x_1)$

$y - 74.7 = 0.17(x - 10)$
 $y - 74.7 = 0.17x - 1.7$
 $y = 0.17x + 73$
 $E(x) = 0.17x + 73$

c. $E(x) = 0.17x + 73$
 $E(60) = 0.17(60) + 73$
 $= 83.2$

The life expectancy of American women born in 2020 is expected to be 83.2.

91. (10, 230) (60, 110) Points may vary.

$m = \frac{110 - 230}{60 - 10} = -\frac{120}{50} = -2.4$

$y - 230 = -2.4(x - 10)$
 $y - 230 = -2.4x + 24$
 $y = -2.4x + 254$

Answers will vary for predictions.

92. – 99. Answers will vary.

100. Two points are (0,4) and (10,24).

$m = \frac{24 - 4}{10 - 0} = \frac{20}{10} = 2.$

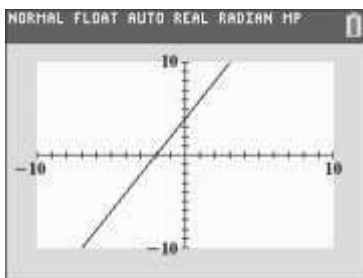

101. Two points are (0, 6) and (10, -24).

$m = \frac{-24 - 6}{10 - 0} = \frac{-30}{10} = -3.$

Check: $y = mx + b : y = -3x + 6.$

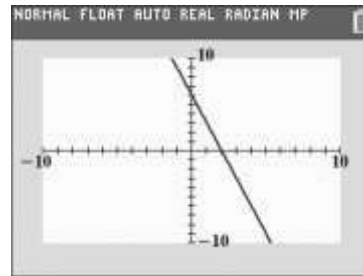

102. Two points are (0,-5) and (10,-10).

$m = \frac{-10 - (-5)}{10 - 0} = \frac{-5}{10} = -\frac{1}{2}.$

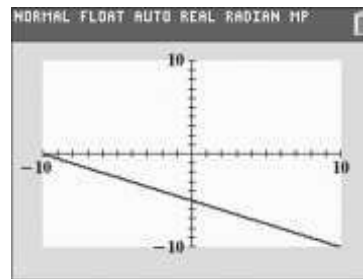

103. Two points are (0, -2) and (10, 5.5).

$m = \frac{5.5 - (-2)}{10 - 0} = \frac{7.5}{10} = 0.75 \text{ or } \frac{3}{4}.$

Check: $y = mx + b : y = \frac{3}{4}x - 2.$

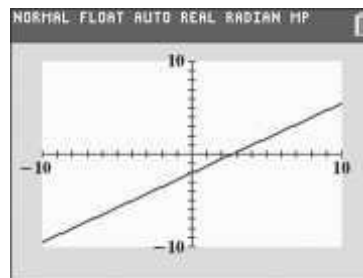

104. a. Enter data from table.

b.

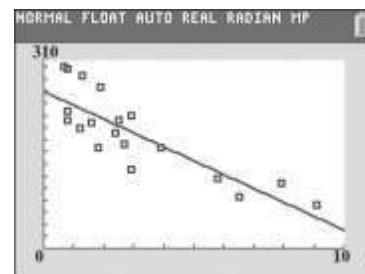

- c. $a = -22.96876741$
 $b = 260.5633751$
 $r = -0.8428126855$

d.

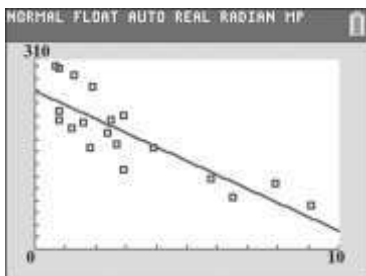

105. does not make sense; Explanations will vary.
 Sample explanation: Linear functions never change from increasing to decreasing.
106. does not make sense; Explanations will vary.
 Sample explanation: Since college cost are going up, this function has a positive slope.
107. does not make sense; Explanations will vary.

Sample explanation: The slope of line's whose equations are in this form can be determined in several ways. One such way is to rewrite the equation in slope-intercept form.

108. makes sense
109. false; Changes to make the statement true will vary.

110. A sample change is: It is possible for m to equal b .
 false; Changes to make the statement true will vary.

A sample change is: Slope-intercept form is $y = mx + b$. Vertical lines have equations of the form $x = a$. Equations of this form have undefined slope and cannot be written in slope-intercept form.

111. true
112. false; Changes to make the statement true will vary.
 A sample change is: The graph of $x = 7$ is a vertical line through the point $(7, 0)$.
113. We are given that the x -intercept is -2 and the y -intercept is 4 . We can use the points $(-2, 0)$ and $(0, 4)$ to find the slope.

$$m = \frac{4 - 0}{0 - (-2)} = \frac{4}{2} = 2$$

$$y - y_1 = m(x - x_1)$$

$$y - 0 = 2(x - (-2))$$

$$y = 2(x + 2)$$

$$y = 2x + 4$$

$$-2x + y = 4$$

Find the x - and y -coefficients for the equation of the line with right-hand-side equal to 12. Multiply both sides of $-2x + y = 4$ by 3 to obtain 12 on the right-hand-side.

$$-2x + y = 4$$

$$3(-2x + y) = 3(4)$$

$$-6x + 3y = 12$$

Therefore, the coefficient of x is -6 and the coefficient of y is 3 .

114. We are given that the y -intercept is -6 and the slope is $\frac{1}{2}$.

So the equation of the line is $y = \frac{1}{2}x - 6$.

We can put this equation in the form $ax + by = c$ to find the missing coefficients.

$$y = \frac{1}{2}x - 6$$

$$y - \frac{1}{2}x = -6$$

$$2\left(\frac{2}{y} - \frac{1}{x}\right) = 2(-6)$$

$$\left(\frac{2}{y} - \frac{1}{x}\right)$$

$$2y - x = -12$$

$$x - 2y = 12$$

Therefore, the coefficient of x is 1 and the coefficient of y is -2 .

115. Answers will vary.
116. Let $(25, 40)$ and $(125, 280)$ be ordered pairs (M, E) where M is degrees Madonna and E is degrees Elvis. Then
- $$m = \frac{280 - 40}{125 - 25} = \frac{240}{100} = 2.4$$
- Using $(x, y) = (25, 40)$ point-slope form tells us that

$$E - 40 = 2.4(M - 25) \text{ or}$$

$$E = 2.4M - 20.$$

Using the slope and one of the intercepts, we can write the line in point-slope form.

117. Answers will vary.

118. Let x = the number of years after 1994.

$$714 - 17x = 289$$

$$-17x = -425$$

$$x = 25$$

Violent crime incidents will decrease to 289 per 100,000 people 25 years after 1994, or 2019.

119.
$$\frac{x+3}{4} \geq \frac{x-2}{3} + 1$$

$$12\left(\frac{x+3}{4}\right) \geq 12\left(\frac{x-2}{3} + 1\right)$$

$$\left(\begin{array}{c} | \\ 4 \\ | \end{array} \right) \left(\begin{array}{c} | \\ 3 \\ | \end{array} \right)$$

$$3(x+3) \geq 4(x-2) + 12$$

$$3x + 9 \geq 4x - 8 + 12$$

$$3x + 9 \geq 4x + 4$$

$$5 \geq x$$

$$x \leq 5$$



The solution set is $\{x|x \leq 5\}$ or $(-\infty, 5]$.

120.
$$3|2x + 6| - 9 < 15$$

$$3|2x + 6| < 24$$

$$3|2x + 6| < 24$$

$$|2x + 6| < 8$$

$$|2x + 6| < 8$$

$$-8 < 2x + 6 < 8$$

$$-14 < 2x < 2$$

$$-7 < x < 1$$



The solution set is $\{x|-7 < x < 1\}$ or $(-7, 1)$.

121. Since the slope is the same as the slope of $y = 2x + 1$, then $m = 2$.

$$y - y_1 = m(x - x_1)$$

$$y - 1 = 2(x - (-3))$$

$$y - 1 = 2(x + 3)$$

$$y - 1 = 2x + 6$$

$$y = 2x + 7$$

122. Since the slope is the negative reciprocal of $-\frac{1}{4}$,

then $m = 4$.

$$y - y_1 = m(x - x_1)$$

$$y - (-5) = 4(x - 3)$$

$$y + 5 = 4x - 12$$

$$-4x + y + 17 = 0$$

$$4x - y - 17 = 0$$

123.
$$\frac{f(x_2) - f(x_1)}{x_2 - x_1} = \frac{f(4) - f(1)}{4 - 1}$$

$$= \frac{4^2 - 1^2}{4 - 1}$$

$$= \frac{15}{3}$$

$$= 5$$

Section 2.4

Check Point Exercises

1. The slope of the line $y = 3x + 1$ is 3.

$$y - y_1 = m(x - x_1)$$

$$y - 5 = 3(x - (-2))$$

$$y - 5 = 3(x + 2) \text{ point-slope}$$

$$y - 5 = 3x + 6$$

$$y = 3x + 11 \text{ slope-intercept}$$

2. a. Write the equation in slope-intercept form:

$$x + 3y - 12 = 0$$

$$3y = -x + 12$$

$$y = -\frac{1}{3}x + 4$$

The slope of this line is $-\frac{1}{3}$ thus the slope of

any line perpendicular to this line is 3.

b. Use $m = 3$ and the point $(-2, -6)$ to write the equation.

$$y - y_1 = m(x - x_1)$$

$$y - (-6) = 3(x - (-2))$$

$$y + 6 = 3(x + 2)$$

$$y + 6 = 3x + 6$$
$$-3x + y = 0$$
$$3x - y = 0 \text{ general form}$$

$$3. \quad m = \frac{\text{Change in } y}{\text{Change in } x} = \frac{15 - 11.2}{2013 - 2000} = \frac{3.8}{13} \approx 0.29$$

The slope indicates that the number of U.S. men living alone increased at a rate of 0.29 million each year.

The rate of change is 0.29 million men per year.

$$\frac{f(x_2) - f(x_1)}{x_2 - x_1} = \frac{1^3 - 0^3}{1 - 0}$$

$$4. \quad \text{a.} \quad \frac{2^3 - 1^3}{2 - 1} = \frac{8 - 1}{1} = 7$$

$$\text{b.} \quad \frac{f(x_2) - f(x_1)}{x_2 - x_1} = \frac{2^3 - 1^3}{2 - 1} = \frac{8 - 1}{1} = 7$$

$$\text{c.} \quad \frac{f(x_2) - f(x_1)}{x_2 - x_1} = \frac{0^3 - (-2)^3}{0 - (-2)} = \frac{8}{2} = 4$$

$$5. \quad \frac{f(x_2) - f(x_1)}{x_2 - x_1} = \frac{f(3) - f(1)}{3 - 1} = \frac{0.05 - 0.03}{3 - 1} = 0.01$$

The average rate of change in the drug's concentration between 1 hour and 3 hours is 0.01 mg per 100 mL per hour.

Concept and Vocabulary Check 2.4

1. the same

2. -1

1

3. $-\frac{1}{3}$; 3

1

4. -2; $\frac{1}{2}$

5. y ; x

$$6. \quad \frac{f(x_2) - f(x_1)}{x_2 - x_1}$$

Exercise Set 2.4

1. Since L is parallel to $y = 2x$, we know it will have slope $m = 2$. We are given that it passes through $(4, 2)$. We use the slope and point to write the equation in point-slope form.

$$y - y_1 = m(x - x_1)$$

$$y - 2 = 2(x - 4)$$

Solve for y to obtain slope-intercept form.

$$y - 2 = 2(x - 4)$$

$$y - 2 = 2x - 8$$

$$y = 2x - 6$$

In function notation, the equation of the line is

$$f(x) = 2x - 6.$$

2. L will have slope $m = -2$. Using the point and the slope, we have $y - 4 = -2(x - 3)$. Solve for y to obtain slope-intercept form.

$$y - 4 = -2x + 6$$

$$y = -2x + 10$$

$$f(x) = -2x + 10$$

3. Since L is perpendicular to $y = 2x$, we know it will have slope $m = -\frac{1}{2}$. We are given that it passes

through $(2, 4)$. We use the slope and point to write the equation in point-slope form.

$$y - y_1 = m(x - x_1)$$

$$y - 4 = -\frac{1}{2}(x - 2)$$

Solve for y to obtain slope-intercept form.

$$y - 4 = -\frac{1}{2}(x - 2)$$

$$y - 4 = -\frac{1}{2}x + 1$$

$$y = -\frac{1}{2}x + 5$$

In function notation, the equation of the line is

$$f(x) = -\frac{1}{2}x + 5.$$

4. L will have slope $m = \frac{1}{2}$. The line passes through

$(-1, 2)$. Use the slope and point to write the equation in point-slope form.

$$y - 2 = \frac{1}{2}(x - (-1))$$

$$y - 2 = \frac{1}{2}(x + 1)$$

Solve for y to obtain slope-intercept form.

$$y - 2 = \frac{1}{2}x + \frac{1}{2}$$

$$y = \frac{1}{2}x + \frac{1}{2} + 2$$

$$y = \frac{1}{2}x + \frac{5}{2}$$

$$f(x) = \frac{1}{2}x + \frac{5}{2}$$

5. $m = -4$ since the line is parallel to

$$y = -4x + 3; x_1 = -8, y_1 = -10;$$

point-slope form: $y + 10 = -4(x + 8)$
 slope-intercept form: $y + 10 = -4x - 32$
 $y = -4x - 42$

6. $m = -5$ since the line is parallel to $y = -5x + 4$;

$$x_1 = -2, y_1 = -7;$$

point-slope form: $y + 7 = -5(x + 2)$
 slope-intercept form: $y + 7 = -5x - 10$
 $y = -5x - 17$

7. $m = -5$ since the line is perpendicular to

$$y = \frac{1}{5}x + 6; x_1 = 2, y_1 = -3;$$

point-slope form: $y + 3 = -5(x - 2)$
 slope-intercept form: $y + 3 = -5x + 10$
 $y = -5x + 7$

8. $m = -3$ since the line is perpendicular to $y = \frac{1}{3}x + 7$;

$$x_1 = -4, y_1 = 2;$$

point-slope form: $y - 2 = -3(x + 4)$
 slope-intercept form: $y - 2 = -3x - 12$
 $y = -3x - 10$

9. $2x - 3y - 7 = 0$
 $-3y = -2x + 7$

$$y = \frac{2}{3}x - \frac{7}{3}$$

The slope of the given line is $\frac{2}{3}$, so $m = \frac{2}{3}$ since the

lines are parallel.

point-slope form: $y - 2 = \frac{2}{3}(x + 2)$

general form: $2x - 3y + 10 = 0$

10. $3x - 2y - 5 = 0$

$$-2y = -3x + 5$$

$$y = \frac{3}{2}x - \frac{5}{2}$$

The slope of the given line is $\frac{3}{2}$, so $m = \frac{3}{2}$ since the

lines are parallel.

point-slope form: $y - 3 = \frac{3}{2}(x + 1)$

general form: $3x - 2y + 9 = 0$

11. $x - 2y - 3 = 0$

$$-2y = -x + 3$$

$$y = \frac{1}{2}x - \frac{3}{2}$$

The slope of the given line is $\frac{1}{2}$, so $m = -2$ since the

lines are perpendicular.

point-slope form: $y + 7 = -2(x - 4)$

general form: $2x + y - 1 = 0$

12. $x + 7y - 12 = 0$

$$7y = -x + 12$$

$$y = -\frac{1}{7}x + \frac{12}{7}$$

The slope of the given line is $-\frac{1}{7}$, so $m = 7$ since the

lines are perpendicular.

point-slope form: $y + 9 = 7(x - 5)$

general form: $7x - y - 44 = 0$

13. $\frac{15-0}{5-0} = \frac{15}{5} = 3$ —

14. $\frac{24-0}{4-0} = \frac{24}{4} = 6$ —

$$15. \frac{5^2 + 2 \cdot 5 - (3^2 + 2 \cdot 3)}{5 - 3} = \frac{25 + 10 - (9 + 6)}{2} = \frac{20}{2} = 10$$

$$6^2 - 2(6) - (3^2 - 2 \cdot 3) = \frac{36 - 12 - (9 - 6)}{21}$$

$$16. \frac{\quad}{6 - 3} = 3 = \frac{\quad}{3} = 7$$

$$17. \frac{\sqrt{9} - \sqrt{4} - 2}{9 - 4} = \frac{1}{5}$$

$$18. \frac{16 - 9 - \sqrt{4} - 3}{16 - 9} = \frac{1}{7}$$

19. Since the line is perpendicular to $x = 6$ which is a vertical line, we know the graph of f is a horizontal line with 0 slope. The graph of f passes through $(-1, 5)$, so the equation of f is $f(x) = 5$.

20. Since the line is perpendicular to $x = -4$ which is a vertical line, we know the graph of f is a horizontal line with 0 slope. The graph of f passes through $(-2, 6)$, so the equation of f is $f(x) = 6$.

21. First we need to find the equation of the line with x -intercept of 2 and y -intercept of -4 . This line

We use these

will pass through $(2, 0)$ and $(0, -4)$.

points to find the slope.

$$m = \frac{-4 - 0}{0 - 2} = \frac{-4}{-2} = 2$$

Since the graph of f is perpendicular to this line, it

will have slope $m = -\frac{1}{2}$.

Use the point $(-6, 4)$ and the slope $-\frac{1}{2}$ to find the

equation of the line.

$$y - y_1 = m(x - x_1)$$

$$y - 4 = -\frac{1}{2}(x - (-6))$$

$$y - 4 = -\frac{1}{2}(x + 6)$$

$$y - 4 = -\frac{1}{2}x - 3$$

$$y = -\frac{1}{2}x + 1$$

$$f(x) = -\frac{1}{2}x + 1$$

22. First we need to find the equation of the line with x -intercept of 3 and y -intercept of -9 . This line will pass through $(3, 0)$ and $(0, -9)$. We use these points to find the slope.

$$m = \frac{-9 - 0}{0 - 3} = \frac{-9}{-3} = 3$$

Since the graph of f is perpendicular to this line, it

will have slope $m = -\frac{1}{3}$.

Use the point $(-5, 6)$ and the slope $-\frac{1}{3}$ to find the

$\frac{1}{3}$

equation of the line.

$$y - y_1 = m(x - x_1)$$

$$y - 6 = -\frac{1}{3}(x - (-5))$$

$$y - 6 = -\frac{1}{3}(x + 5)$$

$$y - 6 = -\frac{1}{3}x - \frac{5}{3}$$

$$y = -\frac{1}{3}x + \frac{13}{3}$$

$$f(x) = -\frac{1}{3}x + \frac{13}{3}$$

23. First put the equation $3x - 2y - 4 = 0$ in slope-intercept form.

$$3x - 2y - 4 = 0$$

$$-2y = -3x + 4$$

$$y = \frac{3}{2}x - 2$$

The equation of f will have slope $-\frac{2}{3}$ since it is

perpendicular to the line above and the same y -intercept -2 .

So the equation of f is $f(x) = -\frac{2}{3}x - 2$.

24. First put the equation $4x - y - 6 = 0$ in slope-intercept form.

$$4x - y - 6 = 0$$

$$-y = -4x + 6$$

$$y = 4x - 6$$

The equation of f will have slope $-\frac{1}{4}$ since it is

perpendicular to the line above and the same y -intercept -6 .

So the equation of f is $f(x) = -\frac{1}{4}x - 6$.

25. $p(x) = -0.25x + 22$

26. $p(x) = 0.22x + 3$

27. $m = \frac{1163 - 617}{1998 - 1994} = \frac{546}{4} \approx 137$

There was an average increase of approximately 137 discharges per year.

28. $m = \frac{623 - 1273}{2006 - 2001} = \frac{-650}{5} \approx -130$

There was an average decrease of approximately 130 discharges per year.

29. a. $f(x) = 1.1x^3 - 35x^2 + 264x + 557$
 $f(0) = 1.1(0)^3 - 35(0)^2 + 264(0) + 557 = 557$
 $f(4) = 1.1(4)^3 - 35(4)^2 + 264(4) + 557 = 1123.4$

$$m = \frac{1123.4 - 557}{4 - 0} \approx 142$$

30. a. $f(x) = 1.1x^3 - 35x^2 + 264x + 557$
 $f(0) = 1.1(7)^3 - 35(7)^2 + 264(7) + 557 = 1067.3$
 $f(12) = 1.1(12)^3 - 35(12)^2 + 264(12) + 557 = 585.8$

$$\frac{585.8 - 1067.3}{12 - 7}$$

$$m = \frac{585.8 - 1067.3}{12 - 7} \approx -96$$

- b. This underestimates the decrease by 34 discharges per year.

31. – 36. Answers will vary.

37. $y = \frac{1}{3}x + 1$

$$y = -3x - 2$$

- a. The lines are perpendicular because their slopes are negative reciprocals of each other. This is verified because product of their slopes is -1 .

- b. The lines do not appear to be perpendicular.

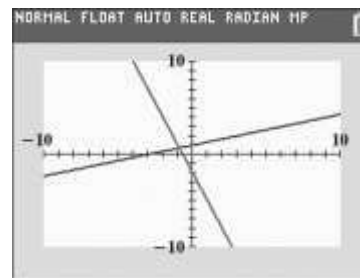

- c. The lines appear to be perpendicular. The calculator screen is rectangular and does not have the same width and height. This causes the scale of the x -axis to differ from the scale on the y -axis despite using the same scale in the window settings. In part (b), this causes the lines not to appear perpendicular when indeed they are. The zoom square feature compensates for this and in part (c), the lines appear to be perpendicular.

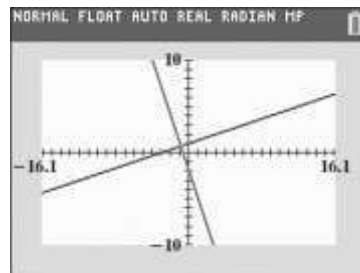

b. This overestimates by 5 discharges per year.

38. does not make sense; Explanations will vary.
Sample explanation: Perpendicular lines have slopes with opposite signs.

39. makes sense
40. does not make sense; Explanations will vary.
Sample explanation: Slopes can be used for segments of the graph.

41. makes sense
42. Write $Ax + By + C = 0$ in slope-intercept form.

$$Ax + By + C = 0$$

$$By = -Ax - C$$

$$\underline{By} = \underline{-Ax} - \underline{C}$$

$$B \quad B \quad B$$

$$A \quad C$$

$$y = -\frac{A}{B}x - \frac{C}{B}$$

The slope of the given line is $-\frac{A}{B}$.

The slope of any line perpendicular to

$$Ax + By + C = 0 \text{ is } \frac{B}{A}.$$

43. The slope of the line containing $(1, -3)$ and $(-2, 4)$ has slope $m = \frac{4 - (-3)}{-2 - 1} = \frac{4 + 3}{-3} = \frac{7}{-3} = -\frac{7}{3}$

Solve $Ax + y - 2 = 0$ for y to obtain slope-intercept form.

$$Ax + y - 2 = 0$$

$$y = -Ax + 2$$

So the slope of this line is $-A$.

This line is perpendicular to the line above so its

slope is $\frac{3}{7}$. Therefore, $-A = \frac{3}{7}$ so $A = -\frac{3}{7}$.

44. $24 + 3(x + 2) = 5(x - 12)$

$$24 + 3x + 6 = 5x - 60$$

$$3x + 30 = 5x - 60$$

$$90 = 2x$$

$$45 = x$$

The solution set is $\{45\}$.

45. Let x = the television's price before the reduction.

$$x - 0.30x = 980$$

$$0.70x = 980$$

46. $2x^{2/3} - 5x^{1/3} - 3 = 0$

$$\text{Let } t = x^{1/3}.$$

$$2t^2 - 5t - 3 = 0$$

$$(2t + 1)(t - 3) = 0$$

$$2t + 1 = 0 \text{ or } t - 3 = 0$$

$$2t = -1$$

$$t = -\frac{1}{2}$$

$$t = 3$$

$$x^{1/3} = -\frac{1}{2}$$

$$x^{1/3} = 3$$

$$\left(-\frac{1}{2}\right)^3$$

$$x = \left(-\frac{1}{2}\right)^3$$

$$x = 3^3$$

$$\left(-\frac{1}{8}\right)$$

$$x = -\frac{1}{8}$$

$$x = 27$$

$$\left(-\frac{1}{8}\right)$$

$$\left(27\right)$$

The solution set is $\left\{-\frac{1}{8}, 27\right\}$.

47. a.

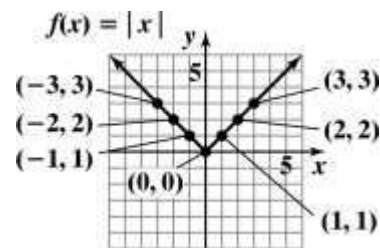

- b.

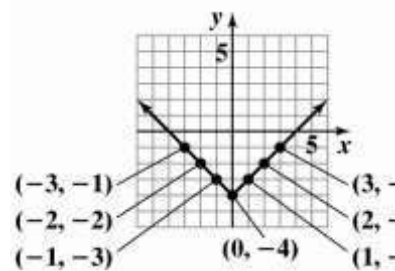

- c. The graph in part (b) is the graph in part (a) shifted down 4 units.

48. a.

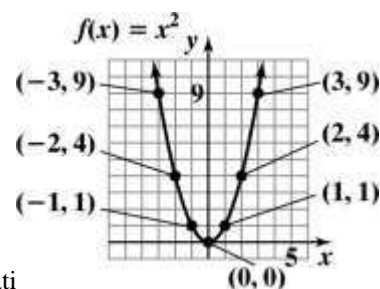

Chapter 2 Functions and Graphs

$$x = \frac{980}{0.70}$$

$$x = 1400$$

Before the reduction the television's price was \$1400.

b.

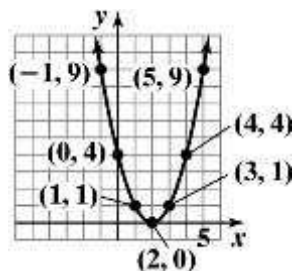

c. The graph in part (b) is the graph in part (a) shifted to the right 2 units.

49. a.

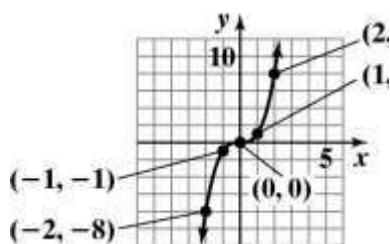

b.

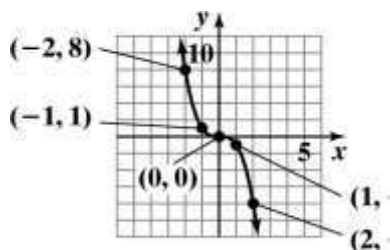

c. The graph in part (b) is the graph in part (a) reflected across the y-axis.

Mid-Chapter 2 Check Point

1. The relation is not a function.
The domain is $\{1, 2\}$.

The range is $\{-6, 4, 6\}$.

2. The relation is a function.
The domain is $\{0, 2, 3\}$.
The range is $\{1, 4\}$.

3. The relation is a function.
The domain is $\{x \mid -2 \leq x < 2\}$.
The range is $\{y \mid 0 \leq y \leq 3\}$.

4. The relation is not a function.
The domain is $\{x \mid -3 < x \leq 4\}$.

The range is $\{y \mid -1 \leq y \leq 2\}$.

5. The relation is not a function.
The domain is $\{-2, -1, 0, 1, 2\}$.
The range is $\{-2, -1, 1, 3\}$.

6. The relation is a function.
The domain is $\{x \mid x \leq 1\}$.
The range is $\{y \mid y \geq -1\}$.

7. $x^2 + y = 5$
 $y = -x^2 + 5$

For each value of x , there is one and only one value for y , so the equation defines y as a function of x .

8. $x + y^2 = 5$
 $y^2 = 5 - x$
 $y = \pm\sqrt{5 - x}$

Since there are values of x that give more than one value for y (for example, if $x = 4$, then $y = \pm\sqrt{5 - 4} = \pm 1$), the equation does not define y as a function of x .

9. No vertical line intersects the graph in more than one point. Each value of x corresponds to exactly one value of y .

10. Domain: $(-\infty, \infty)$

11. Range: $(-\infty, 4]$

12. x -intercepts: -6 and 2

13. y -intercept: 3

14. increasing: $(-\infty, -2)$

15. decreasing: $(-2, \infty)$

16. $x = -2$

17. $f(-2) = 4$

18. $f(-4) = 3$

19. $f(-7) = -2$ and $f(3) = -2$

20. $f(-6) = 0$ and $f(2) = 0$

21. $(-6, 2)$

22. $f(100)$ is negative.

23. neither; $f(-x) \neq x$ and $f(-x) \neq -x$

24. $\frac{f(x_2) - f(x_1)}{x_2 - x_1} = \frac{f(4) - f(-4)}{4 - (-4)} = \frac{-5 - 3}{4 + 4} = -1$

25. Test for symmetry with respect to the y-axis.

$$x = y^2 + 1$$

$$-x = y^2 + 1$$

$$x = -y^2 - 1$$

The resulting equation is not equivalent to the original. Thus, the graph is not symmetric with respect to the y-axis.

Test for symmetry with respect to the x-axis.

$$x = y^2 + 1$$

$$x = (-y)^2 + 1$$

$$x = y^2 + 1$$

The resulting equation is equivalent to the original. Thus, the graph is symmetric with respect to the x-axis.

Test for symmetry with respect to the origin.

$$x = y^2 + 1$$

$$-x = (-y)^2 + 1$$

$$-x = y^2 + 1$$

$$x = -y^2 - 1$$

The resulting equation is not equivalent to the original. Thus, the graph is not symmetric with respect to the origin.

26. Test for symmetry with respect to the y-axis.

$$y = x^3 - 1$$

$$y = (-x)^3 - 1$$

$$y = -x^3 - 1$$

The resulting equation is not equivalent to the original. Thus, the graph is not symmetric with respect to the y-axis.

Test for symmetry with respect to the x-axis.

$$y = x^3 - 1$$

$$-y = x^3 - 1$$

$$y = -x^3 + 1$$

The resulting equation is not equivalent to the original. Thus, the graph is not symmetric with respect to the x-axis.

Test for symmetry with respect to the origin.

$$y = x^3 - 1$$

$$-y = (-x)^3 - 1$$

$$-y =$$

$$y = x^3 + 1$$

The resulting equation is not equivalent to the original. Thus, the graph is not symmetric with respect to the origin.

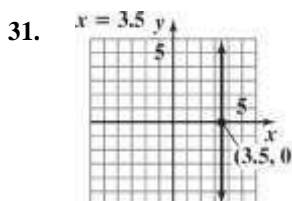
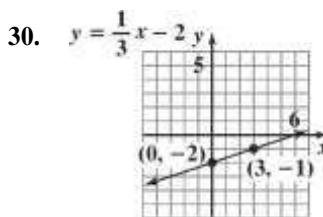
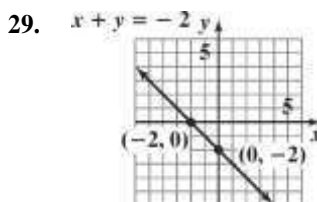
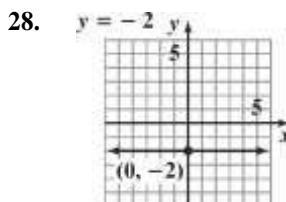
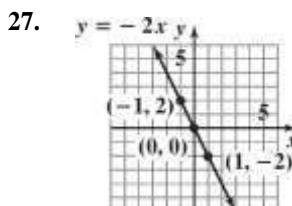

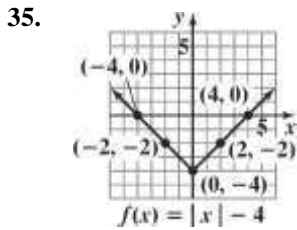
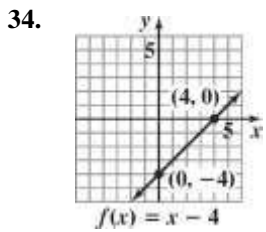
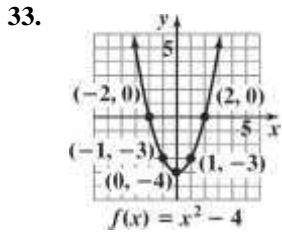
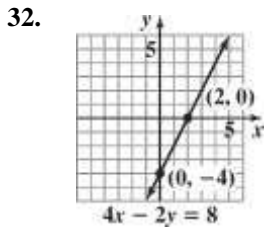

36. $5y = -3x$
 $y = -\frac{3}{5}x$

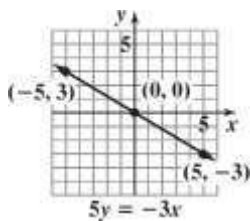

37. $5y = 20$

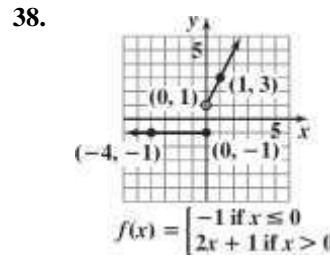
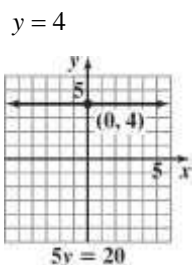

39. a. $f(-x) = -2(-x)^2 - x - 5$
 $= -2x^2 - x - 5$
 neither; $f(-x) \neq x$ and $f(-x) \neq -x$

b. $\frac{f(x+h) - f(x)}{h}$
 $= \frac{-2(x+h)^2 + (x+h) - 5 - (-2x^2 + x - 5)}{h}$
 $= \frac{-2x^2 - 4xh - 2h^2 + x + h - 5 + 2x^2 - x + 5}{h}$
 $= \frac{-4xh - 2h^2 + h}{h}$
 $= \frac{h(-4x - 2h + 1)}{h}$
 $= -4x - 2h + 1$

40. $C(x) = \begin{cases} 30 & \text{if } 0 \leq t \leq 200 \\ 30 + 0.40(t - 200) & \text{if } t > 200 \end{cases}$

a. $C(150) = 30$

b. $C(250) = 30 + 0.40(250 - 200) = 50$

41. $y - y_1 = m(x - x_1)$
 $y - 3 = -2(x - (-4))$
 $y - 3 = -2(x + 4)$
 $y - 3 = -2x - 8$
 $y = -2x - 5$
 $f(x) = -2x - 5$

42. $m = \frac{\text{Change in } y}{\text{Change in } x} = \frac{1 - (-5)}{2 - (-1)} = \frac{6}{3} = 2$

Change in x $2 - (-1) = 3$
 $y - y_1 = m(x - x_1)$
 $y - 1 = 2(x - 2)$
 $y - 1 = 2x - 4$
 $y = 2x - 3$
 $f(x) = 2x - 3$

43. $3x - y - 5 = 0$
 $-y = -3x + 5$
 $y = 3x - 5$

The slope of the given line is 3, and the lines are parallel, so $m = 3$.

$y - y_1 = m(x - x_1)$
 $y - (-4) = 3(x - 3)$
 $y + 4 = 3x - 9$

$y = 3x - 13$
 $f(x) = 3x - 13$

44. $2x - 5y - 10 = 0$
 $-5y = -2x + 10$
 $\frac{-5y}{-5} = \frac{-2x}{-5} + \frac{10}{-5}$
 $y = \frac{2}{5}x - 2$

The slope of the given line is $\frac{2}{5}$, and the lines are

perpendicular, so $m = -\frac{5}{2}$.

$y - y_1 = m(x - x_1)$
 $y - (-3) = -\frac{5}{2}(x - (-4))$
 $y + 3 = -\frac{5}{2}x - 10$
 $y = -\frac{5}{2}x - 13$
 $f(x) = -\frac{5}{2}x - 13$

45. $m_1 = \frac{\text{Change in } y}{\text{Change in } x} = \frac{0 - (-4)}{7 - 2} = \frac{4}{5}$

$m_2 = \frac{\text{Change in } y}{\text{Change in } x} = \frac{6 - 2}{1 - (-4)} = \frac{4}{5}$

The slope of the lines are equal thus the lines are parallel.

46. a. $m = \frac{\text{Change in } y}{\text{Change in } x} = \frac{42 - 26}{180 - 80} = \frac{16}{100} = 0.16$

b. For each minute of brisk walking, the percentage of patients with depression in remission increased by 0.16%. The rate of change is 0.16% per minute of brisk walking.

47. $\frac{f(x_2) - f(x_1)}{x_2 - x_1} = \frac{f(2) - f(-1)}{2 - (-1)}$
 $= \frac{(3(2)^2 - 2) - (3(-1)^2 - (-1))}{2 + 1}$
 $= 2$

Section 2.5

Check Point Exercises

1. Shift up vertically 3 units.

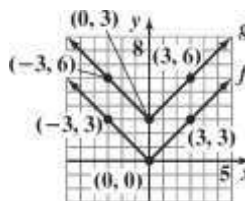

2. Shift to the right 4 units.

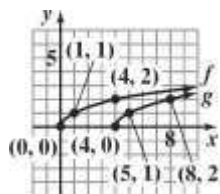

3. Shift to the right 1 unit and down 2 units.

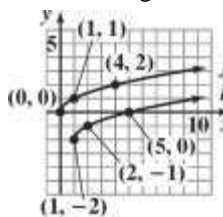

4. Reflect about the x-axis.

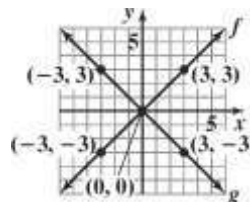

5. Reflect about the y -axis.

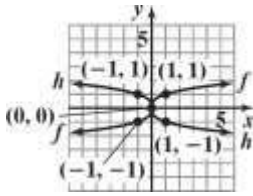

6. Vertically stretch the graph of $f(x) = x^2$.

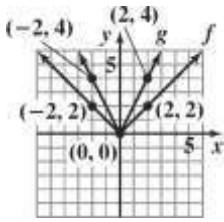

7. a. Horizontally shrink the graph of $y = f(x)$.

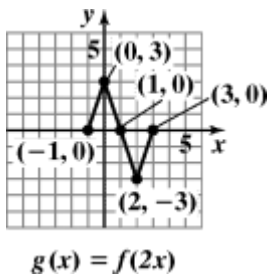

- b. Horizontally stretch the graph of $y = f(x)$.

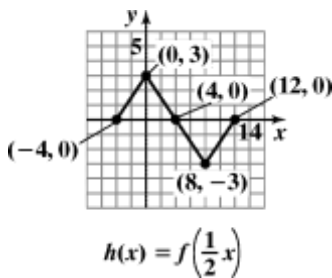

8. The graph of $y = f(x)$ is shifted 1 unit left, shrunk by a factor of $\frac{1}{3}$, reflected about the x -axis, then shifted down 2 units.

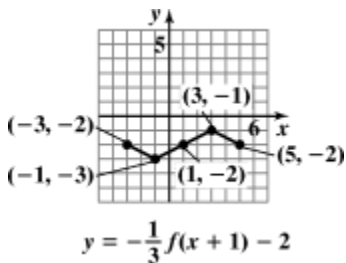

9. The graph of $f(x) = x^2$ is shifted 1 unit right, stretched by a factor of 2, then shifted up 3 units.

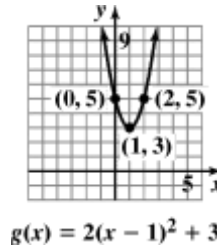

Concept and Vocabulary Check 2.5

- vertical; down
- horizontal; to the right
- x -axis
- y -axis
- vertical; y
- horizontal; x
- false

Exercise Set 2.5

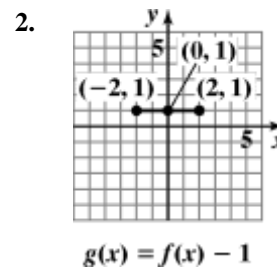
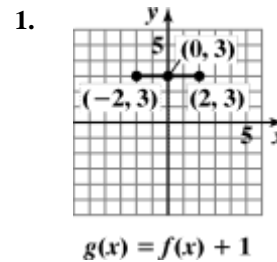

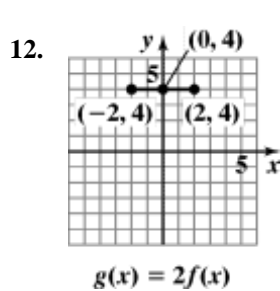
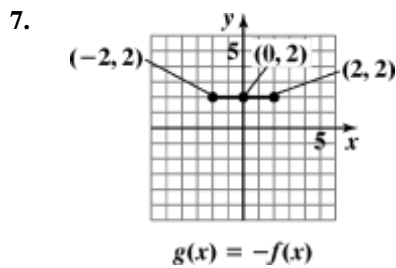
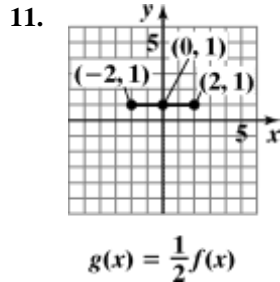
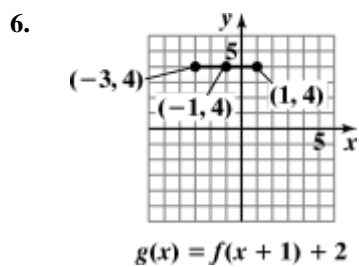
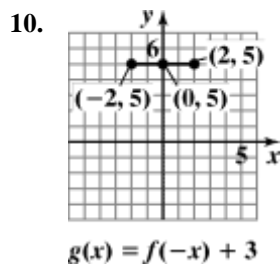
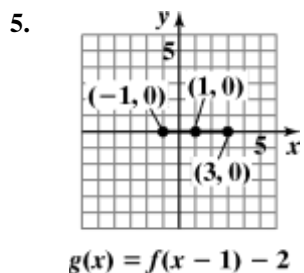
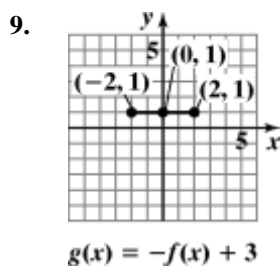
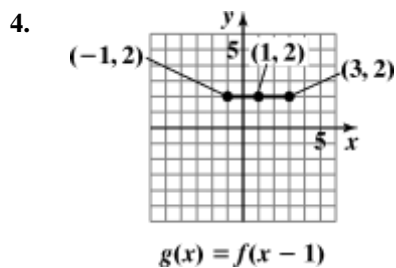
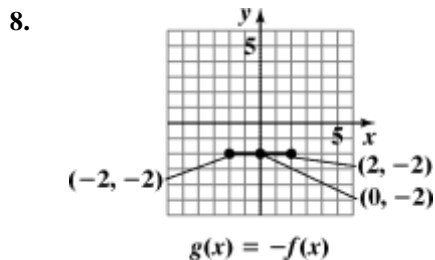
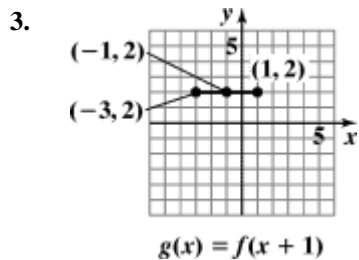

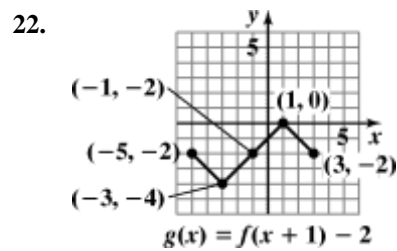
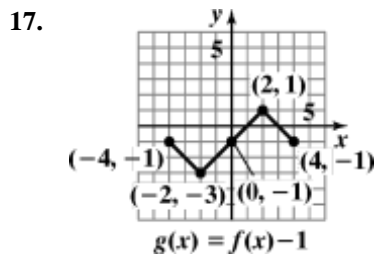
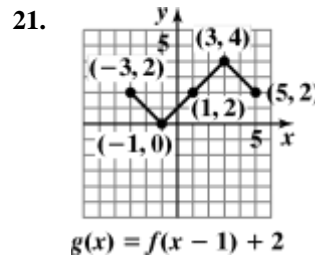
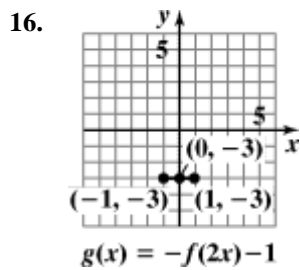
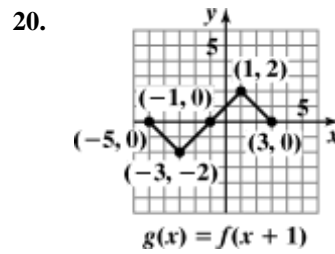
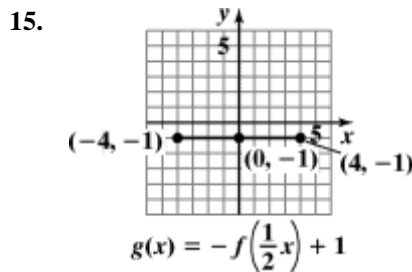
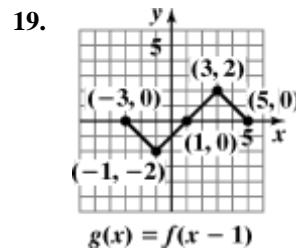
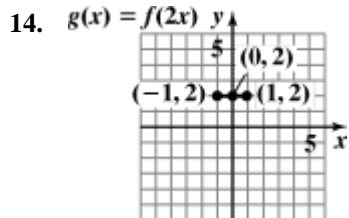
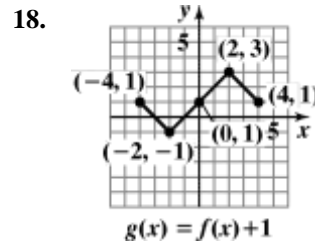
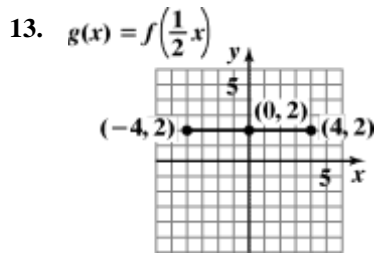

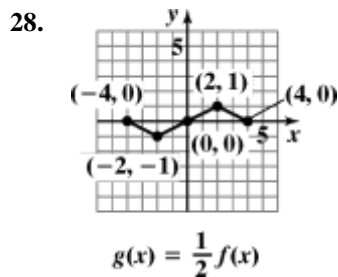
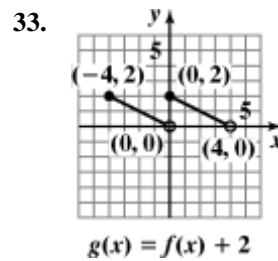
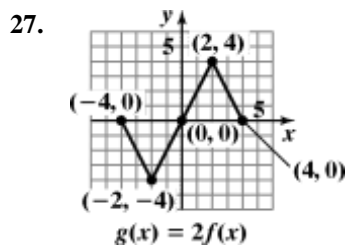
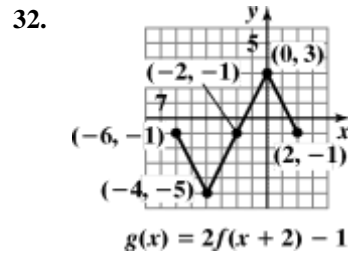
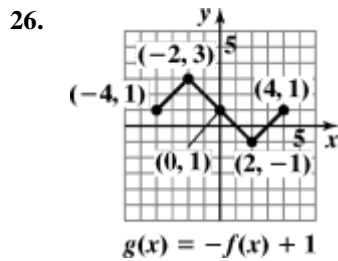
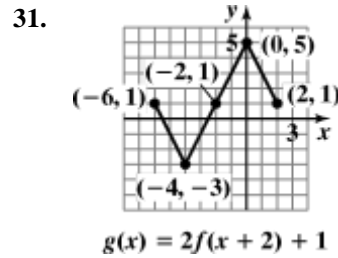
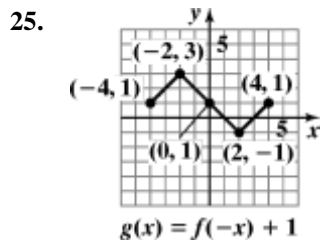
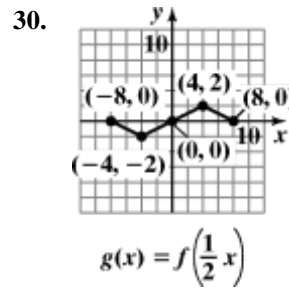
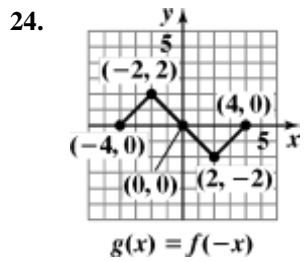
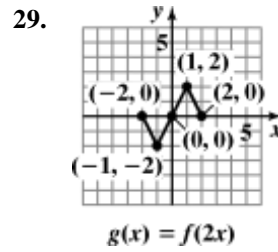
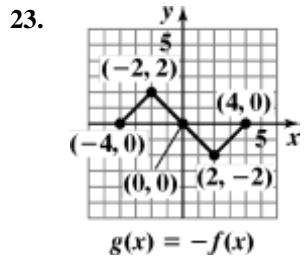

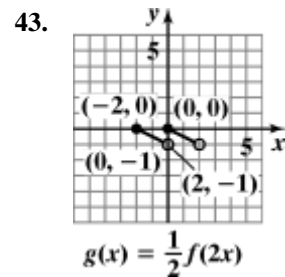
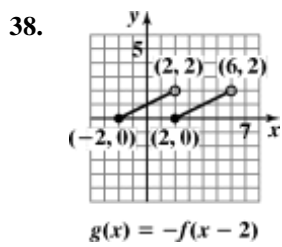
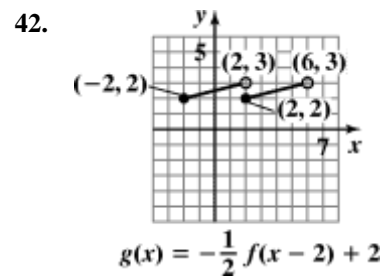
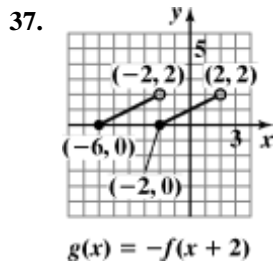
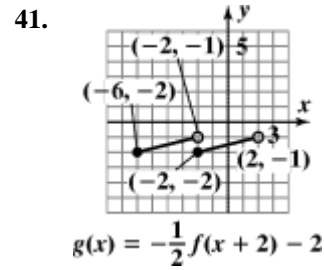
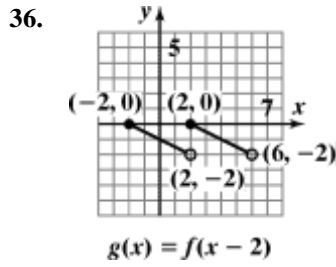
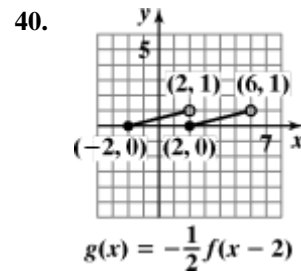
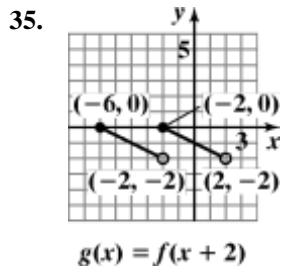
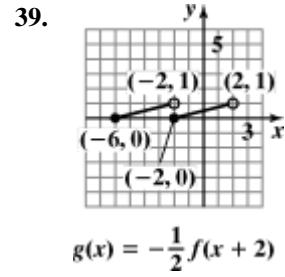
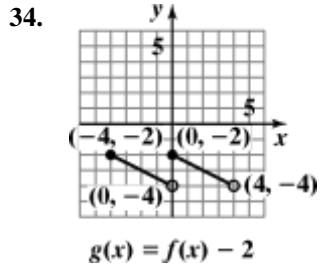

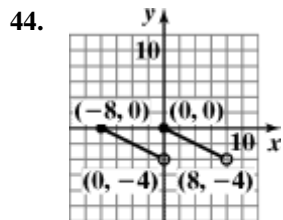

$$g(x) = 2f\left(\frac{1}{2}x\right)$$

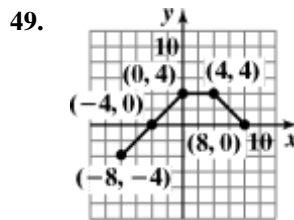

$$g(x) = 2f\left(\frac{1}{2}x\right)$$

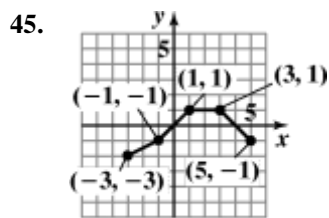

$$g(x) = f(x - 1) - 1$$

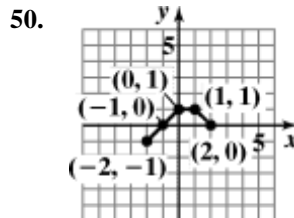

$$g(x) = \frac{1}{2}f(2x)$$

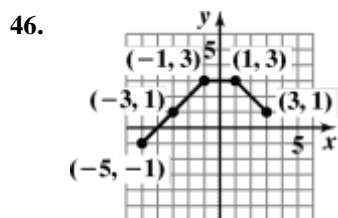

$$g(x) = f(x + 1) + 1$$

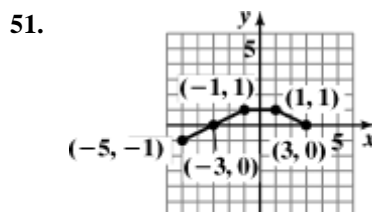

$$g(x) = \frac{1}{2}f(x + 1)$$

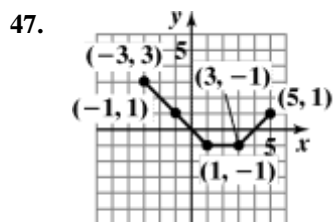

$$g(x) = -f(x - 1) + 1$$

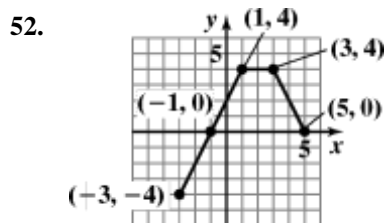

$$g(x) = 2f(x - 1)$$

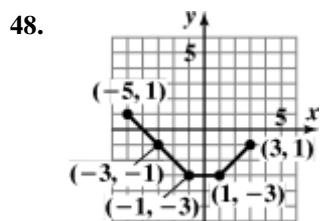

$$g(x) = -f(x + 1) - 1$$

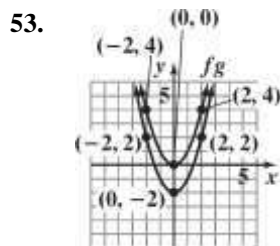

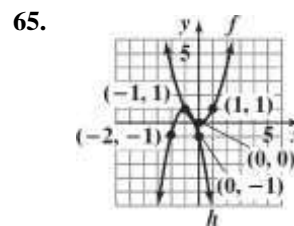
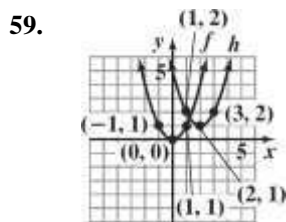
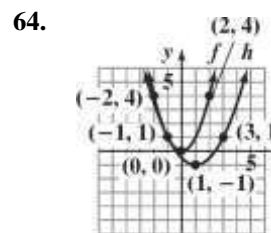
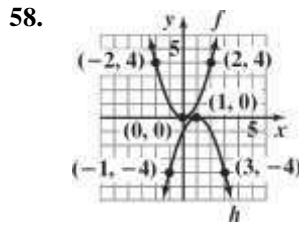
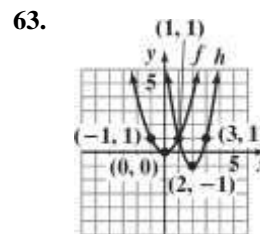
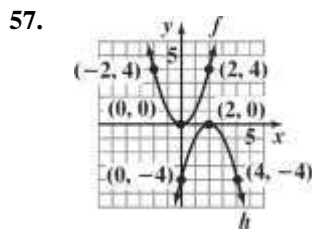
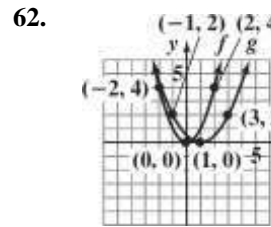
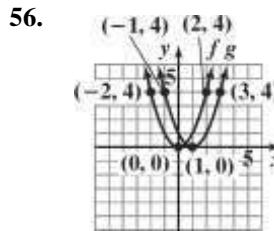
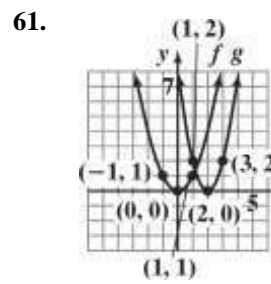
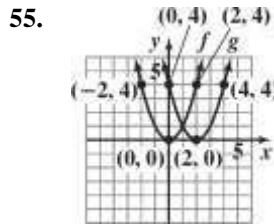
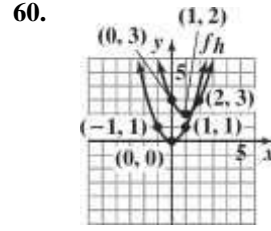
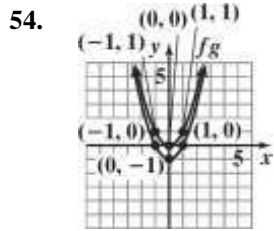

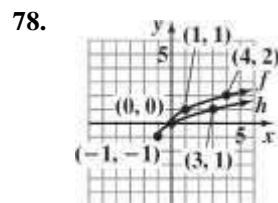
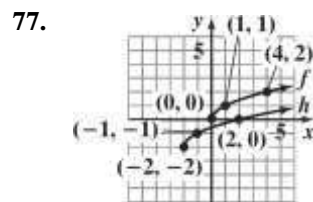
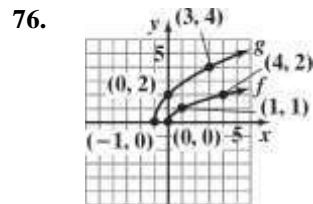
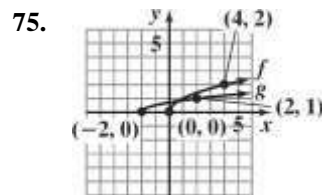
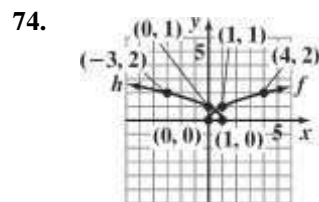
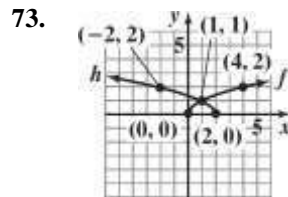
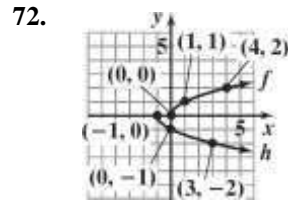
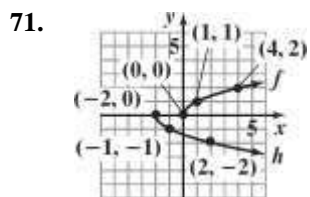
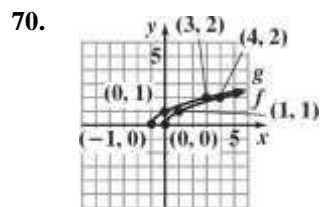
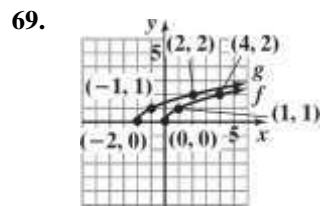
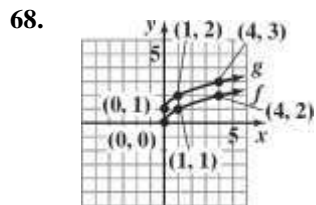
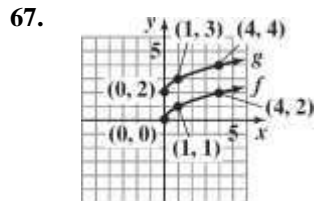
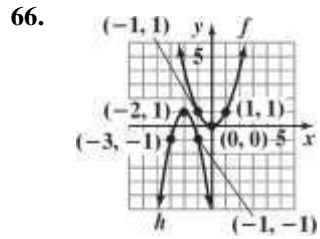

79.

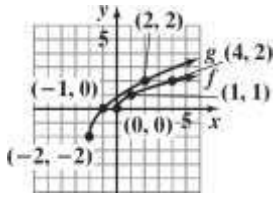

86.

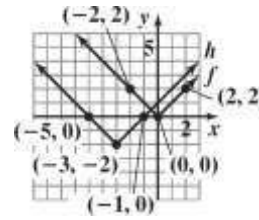

80.

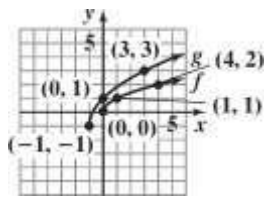

87.

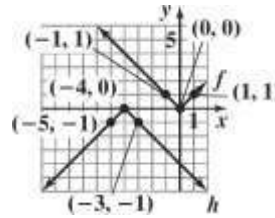

81.

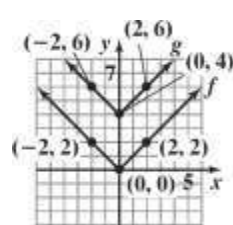

88.

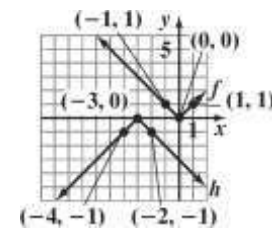

82.

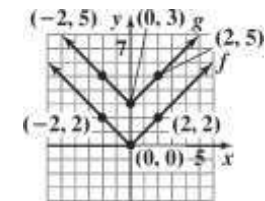

89.

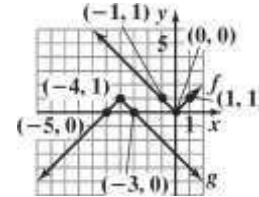

83.

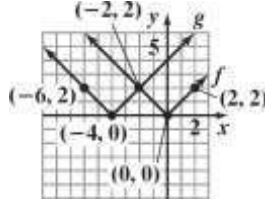

90.

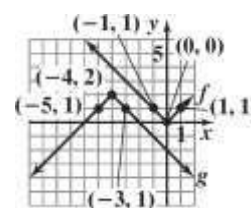

84.

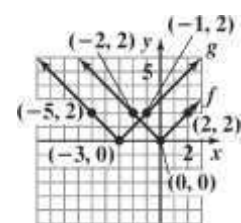

91.

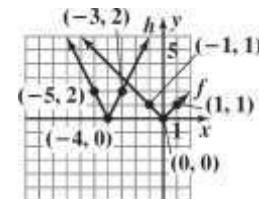

85.

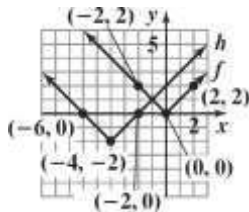

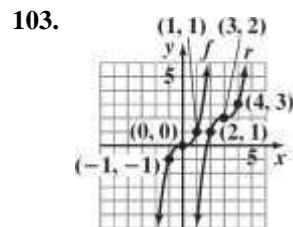
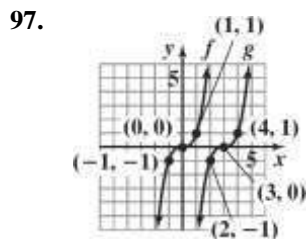
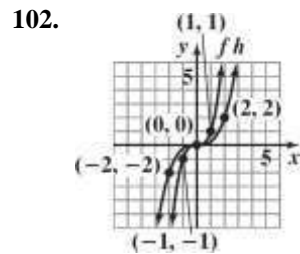
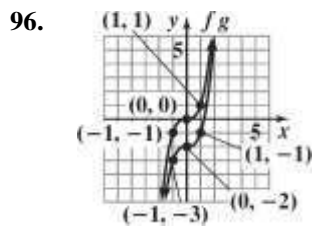
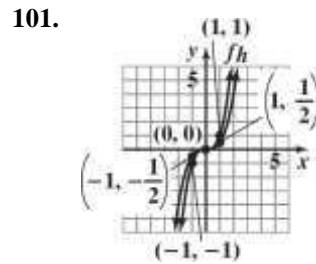
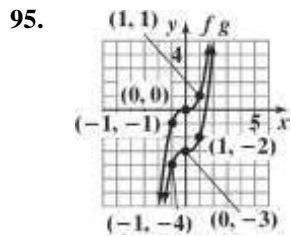
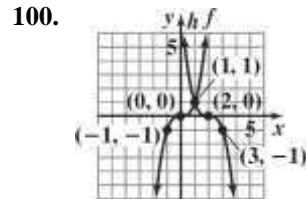
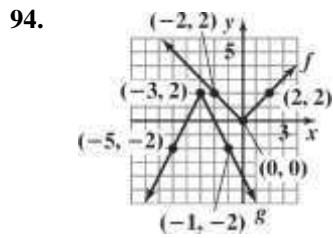
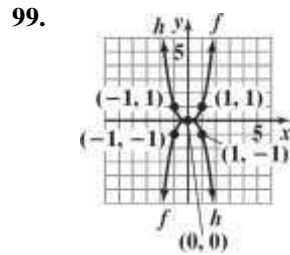
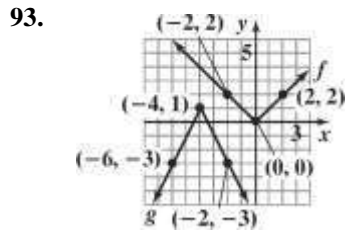
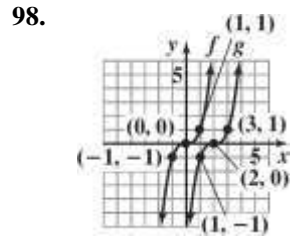
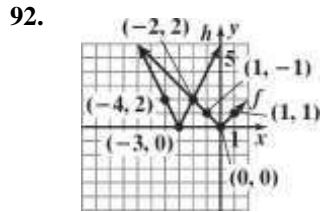

104.

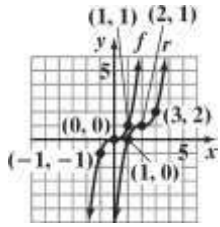

110.

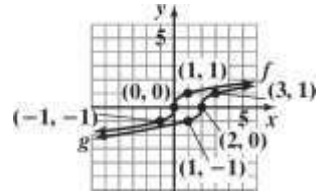

105.

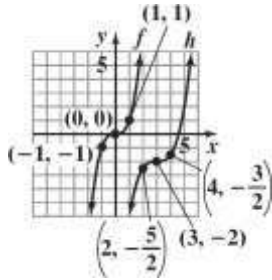

111.

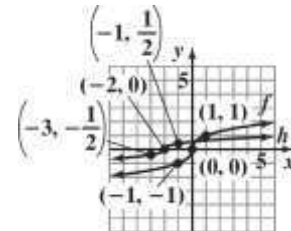

106.

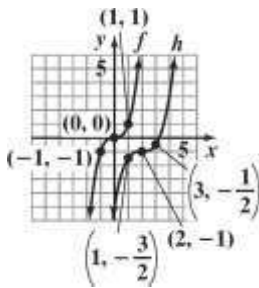

112.

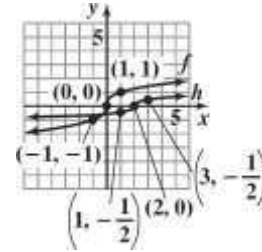

107.

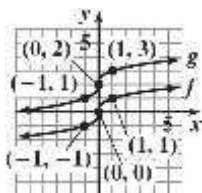

113.

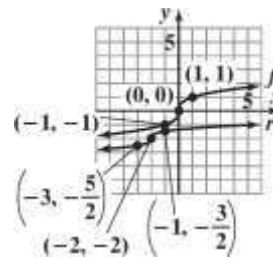

108.

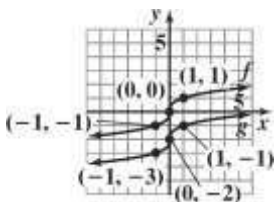

114.

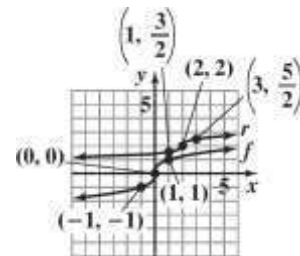

109.

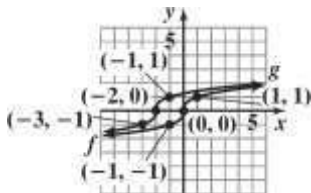

115.

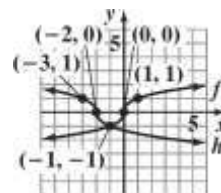

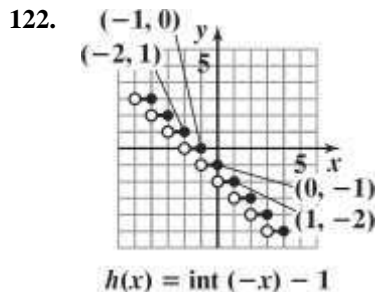
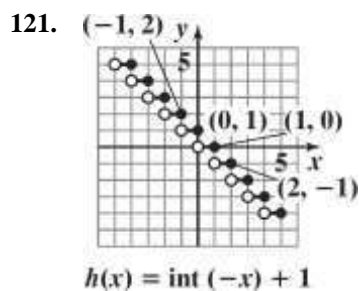
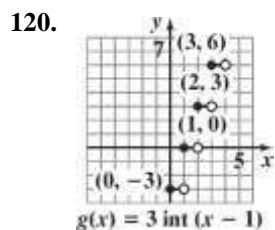
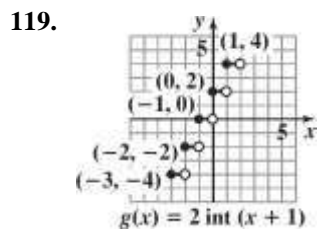
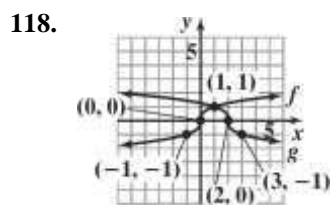
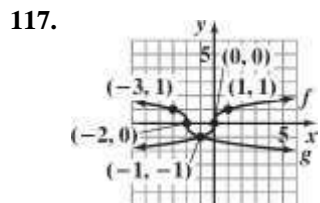
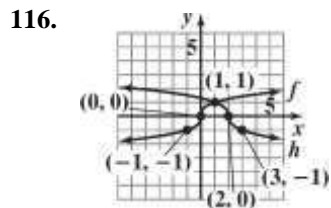

123. $y = \sqrt{x-2}$

124. $y = -x^3 + 2$

125. $y = (x+1)^2 - 4$

126. $y = \sqrt{x-2} + 1$

127. a. First, vertically stretch the graph of $f(x) = \sqrt{x}$ by the factor 2.9; then shift the result up 20.1 units.

b. $f(x) = 2.9\sqrt{x} + 20.1$

$f(48) = 2.9\sqrt{48} + 20.1 \approx 40.2$

The model describes the actual data very well.

c.
$$\frac{f(x_2) - f(x_1)}{x_2 - x_1}$$

$$= \frac{f(10) - f(0)}{10 - 0}$$

$$= \frac{(2.9\sqrt{10} + 20.1) - (2.9\sqrt{0} + 20.1)}{10 - 0}$$

$$= \frac{29.27 - 20.1}{10}$$

$$\approx 0.9$$

0.9 inches per month

d.
$$\frac{f(x_2) - f(x_1)}{x_2 - x_1}$$

$$= \frac{f(60) - f(50)}{60 - 50}$$

$$= \frac{(2.9\sqrt{60} + 20.1) - (2.9\sqrt{50} + 20.1)}{60 - 50}$$

$$= \frac{42.5633 - 40.6061}{10}$$

$$\approx 0.2$$

This rate of change is lower than the rate of change in part (c). The relative leveling off of the curve shows this difference.

128. a. First, vertically stretch the graph of $f(x) = \sqrt{x}$ by the factor 3.1; then shift the result up 19 units.

b. $f(x) = 3.1\sqrt{x} + 19$
 $f(48) = 3.1\sqrt{48} + 19 \approx 40.5$
 The model describes the actual data very well.

c.
$$\frac{f(x_2) - f(x_1)}{x_2 - x_1}$$

$$= \frac{f(10) - f(0)}{10 - 0}$$

$$= \frac{(3.1\sqrt{10} + 19) - (3.1\sqrt{0} + 19)}{10 - 0}$$

$$= \frac{28.8031 - 19}{10}$$

$$\approx 1.0$$
 1.0 inches per month

d.
$$\frac{f(x_2) - f(x_1)}{x_2 - x_1}$$

$$= \frac{f(60) - f(50)}{60 - 50}$$

$$= \frac{(3.1\sqrt{60} + 19) - (3.1\sqrt{50} + 19)}{60 - 50}$$

$$= \frac{43.0125 - 40.9203}{10}$$

$$\approx 0.2$$
 This rate of change is lower than the rate of change in part (c). The relative leveling off of the curve shows this difference.

129. – 134. Answers will vary.

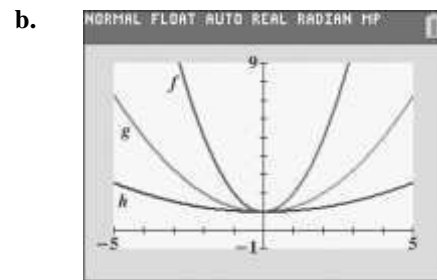
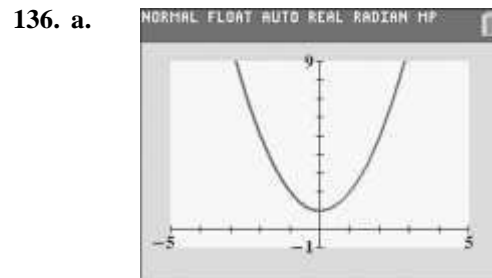
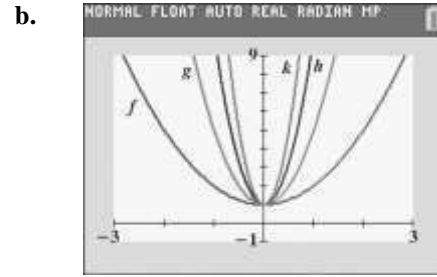
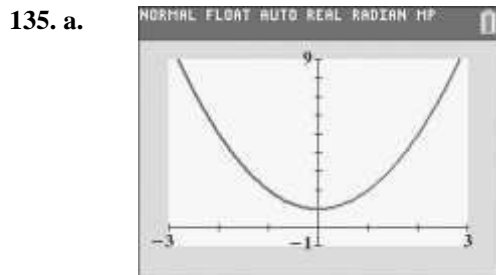

137. makes sense
 138. makes sense
 139. does not make sense; Explanations will vary. Sample explanation: The reprogram should be $y = f(t + 1)$.
 140. does not make sense; Explanations will vary. Sample explanation: The reprogram should be $y = f(t - 1)$.
 141. false; Changes to make the statement true will vary. A sample change is: The graph of g is a translation of f three units to the left and three units upward.
 142. false; Changes to make the statement true will vary. A sample change is: The graph of f is a reflection of the graph of $y = \sqrt{x}$ in the x-axis, while the graph of g is a reflection of the graph of $y = \sqrt{x}$ in the y-axis.
 143. false; Changes to make the statement true will vary. A sample change is: The stretch will be 5 units and the downward shift will be 10 units.

144. true

145. $g(x) = -(x + 4)^2$

146. $g(x) = -\frac{1}{2}x - 5\frac{1}{2} + 1$

147. $g(x) = -\sqrt{x-2} + 2$

148. $g(x) = -\frac{1}{4}\sqrt{16-x^2} - 1$

149. $(-a, b)$

150. $(a, 2b)$

151. $(a + 3, b)$

152. $(a, b - 3)$

153. Let x = the width of the rectangle.
Let $x + 13$ = the length of the rectangle.

$$\begin{aligned} 2l + 2w &= P \\ 2(x+13) + 2x &= 82 \end{aligned}$$

$$2x + 26 + 2x = 82$$

$$4x + 26 = 82$$

$$4x = 56$$

$$x = \frac{56}{4}$$

$$x = 14$$

$$x + 13 = 27$$

The dimensions of the rectangle are 14 yards by 27 yards.

154. $\sqrt{x+10} - 4 = x$
 $\sqrt{x+10} = x + 4$
 $(\sqrt{x+10})^2 = (x+4)^2$

$$x + 10 = x^2 + 8x + 16$$

$$0 = x^2 + 7x + 6$$

$$0 = (x + 6)(x + 1)$$

$$x + 6 = 0 \quad \text{or} \quad x + 1 = 0$$

$$x = -6 \quad \quad \quad x = -1$$

-6 does not check and must be rejected.

The solution set is $\{-1\}$.

155. $(3 - 7i)(5 + 2i) = 15 + 6i - 35i - 14i^2$
 $= 15 + 6i - 35i - 14(-1)$
 $= 15 + 6i - 35i + 14$
 $= 29 - 29i$

156. $(2x - 1)(x^2 + x - 2) = 2x(x^2 + x - 2) - 1(x^2 + x - 2)$
 $= 2x^3 + 2x^2 - 4x - x^2 - x + 2$
 $= 2x^3 + 2x^2 - x^2 - 4x - x + 2$
 $= 2x^3 + x^2 - 5x + 2$

157. $(f(x))^2 - 2f(x) + 6 = (3x - 4)^2 - 2(3x - 4) + 6$
 $= 9x^2 - 24x + 16 - 6x + 8 + 6$
 $= 9x^2 - 24x - 6x + 16 + 8 + 6$
 $= 9x^2 - 30x + 30$

158. $\frac{3}{x-1} = \frac{3x}{x-x} = \frac{3x}{3-x}$

Section 2.6

Check Point Exercises

1. a. The function $f(x) = x^2 + 3x - 17$ contains neither division nor an even root. The domain of f is the set of all real numbers or $(-\infty, \infty)$.

b. The denominator equals zero when $x = 7$ or $x = -7$. These values must be excluded from the domain.
 domain of $g = (-\infty, -7) \cup (-7, 7) \cup (7, \infty)$.

c. Since $h(x) = 9\sqrt{x-27}$ contains an even root; the quantity under the radical must be greater than or equal to 0.
 $9x - 27 \geq 0$

$$9x \geq 27$$

$$x \geq 3$$

Thus, the domain of h is $\{x \mid x \geq 3\}$, or the interval $[3, \infty)$.

d. Since the denominator of $j(x)$ contains an even root; the quantity under the radical must be greater than or equal to 0. But that quantity must also not be 0 (because we cannot have division by 0).

Thus, $24 - 3x$ must be strictly greater than 0.

$$24 - 3x > 0$$

$$-3x > -24$$

$$x < 8$$

Thus, the domain of j is $\{x \mid x < 8\}$, or the interval $(-\infty, 8)$.

2. a. $(f+g)(x) = f(x) + g(x)$
 $= x - 5 + (x^2 - 1)$
 $= x - 5 + x^2 - 1$
 $= -x^2 + x - 6$
 domain: $(-\infty, \infty)$

b. $(f-g)(x) = f(x) - g(x)$
 $= x - 5 - (x^2 - 1)$
 $= x - 5 - x^2 + 1$
 $= -x^2 + x - 4$
 domain: $(-\infty, \infty)$

c. $(fg)(x) = (x-5)(x^2-1)$
 $= x(x^2-1) - 5(x^2-1)$
 $= x^3 - x - 5x^2 + 5$
 $= x^3 - 5x^2 - x + 5$
 domain: $(-\infty, \infty)$

d. $\left(\frac{f}{g}\right)(x) = \frac{f(x)}{g(x)}$
 $= \frac{x-5}{x^2-1}, x \neq \pm 1$
 domain: $(-\infty, -1) \cup (-1, 1) \cup (1, \infty)$

3. a. $(f+g)(x) = f(x) + g(x)$
 $= \sqrt{x-3} + \sqrt{x+1}$

b. domain of f : $x - 3 \geq 0$
 $[3, \infty)$
 domain of g : $x + 1 \geq 0$
 $x \geq -1$

4. a. $(B+D)(x)$
 $= B(x) + D(x)$
 $= (-2.6x^2 + 49x + 3994) + (-0.6x^2 + 7x + 2412)$
 $= -2.6x^2 + 49x + 3994 - 0.6x^2 + 7x + 2412$
 $= -3.2x^2 + 56x + 6406$

b. $(B+D)(x) = -3.2x^2 + 56x + 6406$
 $(B+D)(5) = -3.2(3)^2 + 56(3) + 6406$
 $= 6545.2$

The number of births and deaths in the U.S. in 2003 was 6545.2 thousand.

c. $(B+D)(x)$ overestimates the actual number of births and deaths in 2003 by 7.2 thousand.

5. a. $(f \circ g)(x) = f(g(x))$
 $= 5(2x^2 - x - 1) + 6$
 $= 10x^2 - 5x - 5 + 6$
 $= 10x^2 - 5x + 1$

b. $(g \circ f)(x) = g(f(x))$
 $= 2(5x+6)^2 - (5x+6) - 1$
 $= 2(25x^2 + 60x + 36) - 5x - 6 - 1$
 $= 50x^2 + 120x + 72 - 5x - 6 - 1$
 $= 50x^2 + 115x + 65$

c. $(f \circ g)(x) = 10x^2 - 5x + 1$
 $(f \circ g)(-1) = 10(-1)^2 - 5(-1) + 1$
 $= 10 + 5 + 1$
 $= 16$

6. a. $(f \circ g)(x) = \frac{4}{x} = \frac{4x}{x^2}$
 $\frac{1}{x} + 2 = \frac{1+2x}{x}$

b. domain: $\{x \mid x \neq 0, x \neq -\frac{1}{2}\}$
 or $\left(-\infty, -\frac{1}{2}\right) \cup \left(-\frac{1}{2}, 0\right) \cup (0, \infty)$
 $\left(-\frac{1}{2}, \infty\right)$

The domain of $f + g$ is the set of all real numbers that are common to the domain of f and the domain of g . Thus, the domain of $f + g$ is $[3, \infty)$.

7. $h(x) = f \circ g$ where $f(x) = x$; $g(x) = x^2 + 5$

Concept and Vocabulary Check 2.6

1. zero
2. negative
3. $f(x) + g(x)$
4. $f(x) - g(x)$
5. $f(x) \cdot g(x)$
6. $\frac{f(x)}{g(x)}$; $g(x)$
7. $(-\infty, \infty)$
8. $(2, \infty)$
9. $(0, 3)$; $(3, \infty)$
10. composition; $f(g(x))$
11. f ; $g(x)$
12. composition; $g(f(x))$
13. g ; $f(x)$
14. false
15. false
16. 2

Exercise Set 2.6

1. The function contains neither division nor an even root. The domain = $(-\infty, \infty)$
2. The function contains neither division nor an even root. The domain = $(-\infty, \infty)$
3. The denominator equals zero when $x = 4$. This value must be excluded from the domain.
domain: $(-\infty, 4) \cup (4, \infty)$.
4. The denominator equals zero when $x = -5$. This value must be excluded from the domain.
domain: $(-\infty, -5) \cup (-5, \infty)$.

5. The function contains neither division nor an even root. The domain = $(-\infty, \infty)$
6. The function contains neither division nor an even root. The domain = $(-\infty, \infty)$
7. The values that make the denominator equal zero must be excluded from the domain.
domain: $(-\infty, -3) \cup (-3, 5) \cup (5, \infty)$
8. The values that make the denominator equal zero must be excluded from the domain.
domain: $(-\infty, -4) \cup (-4, 3) \cup (3, \infty)$
9. The values that make the denominators equal zero must be excluded from the domain.
domain: $(-\infty, -7) \cup (-7, 9) \cup (9, \infty)$
10. The values that make the denominators equal zero must be excluded from the domain.
domain: $(-\infty, -8) \cup (-8, 10) \cup (10, \infty)$
11. The first denominator cannot equal zero. The values that make the second denominator equal zero must be excluded from the domain.
domain: $(-\infty, -1) \cup (-1, 1) \cup (1, \infty)$
12. The first denominator cannot equal zero. The values that make the second denominator equal zero must be excluded from the domain.
domain: $(-\infty, -2) \cup (-2, 2) \cup (2, \infty)$
13. Exclude x for $x = 0$.

Exclude x for $\frac{3}{x} - 1 = 0$.

$$\begin{array}{l} x \left(\frac{3}{3^x} - 1 \right) = 0 \\ \quad \quad \quad | \quad -1 = x(0) \\ \quad \quad \quad \left(\frac{x}{3-x} \right) \\ \quad \quad \quad \quad \quad 3-x=0 \\ \quad \quad \quad \quad \quad -x=-3 \\ \quad \quad \quad \quad \quad x=3 \end{array}$$

domain: $(-\infty, 0) \cup (0, 3) \cup (3, \infty)$

14. Exclude x for $x = 0$.

Exclude x for $\frac{4}{x} - 1 = 0$.

$$\frac{4}{x} - 1 = 0$$

$$x \left(\frac{4}{x} - 1 \right) = x(0)$$

$$\left| \frac{4}{x} - 1 \right|$$

$$\left(\quad \right)$$

$$4 - x = 0$$

$$-x = -4$$

$$x = 4$$

domain: $(-\infty, 0) \cup (0, 4) \cup (4, \infty)$

15. Exclude x for $x - 1 = 0$.

$$x - 1 = 0$$

$$x = 1$$

Exclude x for $\frac{4}{x-1} - 2 = 0$.

$$\frac{4}{x-1} - 2 = 0$$

$$\left(\frac{x-1}{4} - 2 \right) = 0$$

$$(x-1) \left(\frac{4}{x-1} - 2 \right) = (x-1)(0)$$

$$4 - 2(x-1) = 0$$

$$4 - 2x + 2 = 0$$

$$-2x + 6 = 0$$

$$-2x = -6$$

$$x = 3$$

domain: $(-\infty, 1) \cup (1, 3) \cup (3, \infty)$

16. Exclude x for $x - 2 = 0$.

$$x - 2 = 0$$

$$x = 2$$

4

Exclude x for $\frac{4}{x-2} - 3 = 0$.

$$\frac{4}{x-2} - 3 = 0$$

$$(x-2) \left(\frac{4}{x-2} - 3 \right) = (x-2)(0)$$

$$\left(\frac{x-2}{4} - 3 \right) = 0$$

$$4 - 3(x-2) = 0$$

$$4 - 3x + 6 = 0$$

$$-3x + 10 = 0$$

$$-3x = -10$$

$$x = \frac{10}{3}$$

)

17. The expression under the radical must not be negative.

$$x - 3 \geq 0$$

$$x \geq 3$$

domain: $[3, \infty)$

18. The expression under the radical must not be negative.

$$x + 2 \geq 0$$

$$x \geq -2$$

domain: $[-2, \infty)$

19. The expression under the radical must be positive.

$$x - 3 > 0$$

$$x > 3$$

domain: $(3, \infty)$

20. The expression under the radical must be positive.

$$x + 2 > 0$$

$$x > -2$$

domain: $(-2, \infty)$

21. The expression under the radical must not be negative.

$$5x + 35 \geq 0$$

$$5x \geq -35$$

$$x \geq -7$$

domain: $[-7, \infty)$

22. The expression under the radical must not be negative.

$$7x - 70 \geq 0$$

$$7x \geq 70$$

$$x \geq 10$$

domain: $[10, \infty)$

23. The expression under the radical must not be negative.

$$24 - 2x \geq 0$$

$$-2x \geq -24$$

$$\frac{-2x}{-2} \leq \frac{-24}{-2}$$

$$x \leq 12$$

domain: $(-\infty, 12]$

$$\text{domain: } (-\infty, 2) \cup 2, \left(\frac{3}{10}, 10 \right) \cup (10, \infty)$$

$$\left(\frac{3}{3} \right) \left(\frac{3}{3} \right)$$

24. The expression under the radical must not be negative.

$$84 - 6x \geq 0$$

$$-6x \geq -84$$

$$\frac{-6x}{-6} \leq \frac{-84}{-6}$$

$$x \leq 14$$

$$\text{domain: } (-\infty, 14]$$

25. The expressions under the radicals must not be negative.

$$x - 2 \geq 0 \quad \text{and} \quad x + 3 \geq 0$$

$$x \geq 2 \quad \quad \quad x \geq -3$$

To make both inequalities true, $x \geq 2$.

$$\text{domain: } [2, \infty)$$

26. The expressions under the radicals must not be negative.

$$x - 3 \geq 0 \quad \text{and} \quad x + 4 \geq 0$$

$$x \geq 3 \quad \quad \quad x \geq -4$$

To make both inequalities true, $x \geq 3$.

$$\text{domain: } [3, \infty)$$

27. The expression under the radical must not be negative.

$$x - 2 \geq 0$$

$$x \geq 2$$

The denominator equals zero when $x = 5$.

$$\text{domain: } [2, 5) \cup (5, \infty)$$

28. The expression under the radical must not be negative.

$$x - 3 \geq 0$$

$$x \geq 3$$

The denominator equals zero when $x = 6$.

$$\text{domain: } [3, 6) \cup (6, \infty)$$

29. Find the values that make the denominator equal zero and must be excluded from the domain.

$$x^3 - 5x^2 - 4x + 20$$

$$= x^2(x - 5) - 4(x - 5)$$

$$= (x - 5)(x^2 - 4)$$

$$= (x - 5)(x + 2)(x - 2)$$

30. Find the values that make the denominator equal zero and must be excluded from the domain.

$$x^3 - 2x^2 - 9x + 18$$

$$= x^2(x - 2) - 9(x - 2)$$

$$= (x - 2)(x^2 - 9)$$

$$= (x - 2)(x + 3)(x - 3)$$

-3, 2, and 3 must be excluded.

$$\text{domain: } (-\infty, -3) \cup (-3, 2) \cup (2, 3) \cup (3, \infty)$$

31. $(f + g)(x) = 3x + 2$

$$\text{domain: } (-\infty, \infty)$$

$$(f - g)(x) = f(x) - g(x)$$

$$= (2x + 3) - (x - 1)$$

$$= x + 4$$

$$\text{domain: } (-\infty, \infty)$$

$$(fg)(x) = f(x) \cdot g(x)$$

$$= (2x + 3) \cdot (x - 1)$$

$$= 2x^2 + x - 3$$

$$\text{domain: } (-\infty, \infty)$$

$$\left(\frac{f}{g}\right)(x) = \frac{f(x)}{g(x)} = \frac{2x + 3}{x - 1}$$

$$\left(\frac{g}{f}\right)(x) = \frac{g(x)}{f(x)} = \frac{x - 1}{2x + 3}$$

$$\text{domain: } (-\infty, 1) \cup (1, \infty)$$

32. $(f + g)(x) = 4x - 2$

$$\text{domain: } (-\infty, \infty)$$

$$(f - g)(x) = (3x - 4) - (x + 2) = 2x - 6$$

$$\text{domain: } (-\infty, \infty)$$

$$(fg)(x) = (3x - 4)(x + 2) = 3x^2 + 2x - 8$$

$$\text{domain: } (-\infty, \infty)$$

$$\left(\frac{f}{g}\right)(x) = \frac{3x - 4}{x + 2}$$

$$\text{domain: } (-\infty, -2) \cup (-2, \infty)$$

33. $(f + g)(x) = 3x^2 + x - 5$

$$\text{domain: } (-\infty, \infty)$$

-2, 2, and 5 must be excluded.

$$\text{domain: } (-\infty, -2) \cup (-2, 2) \cup (2, 5) \cup (5, \infty)$$

$$(f - g)(x) = -3x^2 + x$$

- 5 domain: $(-\infty, \infty)$

$$(fg)(x) = (x - 5)(3x^2) = 3x^3 - 15x^2$$

domain: $(-\infty, \infty)$

$$\left. \begin{matrix} f \\ g \end{matrix} \right| (x) = \frac{x - 5}{3x^2}$$

domain: $(-\infty, 0) \cup (0, \infty)$

()

34. $(f + g)(x) = 5x^2 + x - 6$
 domain: $(-\infty, \infty)$
 $(f - g)(x) = -5x^2 + x - 6$
 domain: $(-\infty, \infty)$
 $(fg)(x) = (x - 6)(5x^2) = 5x^3 - 30x^2$
 domain: $(-\infty, \infty)$
 $\left(\frac{f}{g}\right)(x) = \frac{x - 6}{5x^2}$
 domain: $(-\infty, 0) \cup (0, \infty)$
35. $(f + g)(x) = 2x^2 - 2$
 domain: $(-\infty, \infty)$
 $(f - g)(x) = 2x^2 - 2x - 4$
 domain: $(-\infty, \infty)$
 $(fg)(x) = (2x^2 - x - 3)(x + 1)$
 $= 2x^3 + x^2 - 4x - 3$
 domain: $(-\infty, \infty)$
 $\left(\frac{f}{g}\right)(x) = \frac{2x^2 - x - 3}{x + 1}$
 $\left(\frac{f}{g}\right)(x) = \frac{(2x - 3)(x + 1)}{(x + 1)} = 2x - 3$
 domain: $(-\infty, -1) \cup (-1, \infty)$
36. $(f + g)(x) = 6x^2 - 2$
 domain: $(-\infty, \infty)$
 $(f - g)(x) = 6x^2 - 2x$
 domain: $(-\infty, \infty)$
 $(fg)(x) = (6x^2 - x - 1)(x - 1) = 6x^3 - 7x^2 + 1$
 domain: $(-\infty, \infty)$
 $\left(\frac{f}{g}\right)(x) = \frac{6x^2 - x - 1}{x - 1}$
 domain: $(-\infty, 1) \cup (1, \infty)$
37. $\left(\frac{f + g}{g}\right)(x) = \frac{(3 - x^2) + (x^2 + 2x - 15)}{2x - 12}$
 $= 2x - 12$
 domain: $(-\infty, \infty)$
 $(f - g)(x) = (3 - x^2) - (x^2 + 2x - 15)$
 $= -2x^2 - 2x + 18$
 domain: $(-\infty, \infty)$
 $(fg)(x) = (3 - x^2)(x^2 + 2x - 15)$
 $= -x^4 - 2x^3 + 18x^2 + 6x - 45$
 domain: $(-\infty, \infty)$
38. $(f + g)(x) = (5 - x^2) + (x^2 + 4x - 12)$
 $= 4x - 7$
 domain: $(-\infty, \infty)$
 $(f - g)(x) = (5 - x^2) - (x^2 + 4x - 12)$
 $= -2x^2 - 4x + 17$
 domain: $(-\infty, \infty)$
 $(fg)(x) = (5 - x^2)(x^2 + 4x - 12)$
 $= -x^4 - 4x^3 + 17x^2 + 20x - 60$
 domain: $(-\infty, \infty)$
 $\left(\frac{f}{g}\right)(x) = \frac{5 - x^2}{x^2 + 4x - 12}$
 domain: $(-\infty, -6) \cup (-6, 2) \cup (2, \infty)$
39. $(f + g)(x) = \sqrt{x} + x - 4$
 domain: $[0, \infty)$
 $(f - g)(x) = \sqrt{x} - x + 4$
 domain: $[0, \infty)$
 $(fg)(x) = x\sqrt{x} - 4$
 domain: $[0, \infty)$
 $\left(\frac{f}{g}\right)(x) = \frac{x\sqrt{x}}{x - 4}$
 domain: $[0, 4) \cup (4, \infty)$
40. $(f + g)(x) = \sqrt{x} + x - 5$
 domain: $[0, \infty)$
 $(f - g)(x) = \sqrt{x} - x + 5$
 domain: $[0, \infty)$
 $(fg)(x) = \sqrt{x}(x - 5)$
 domain: $[0, \infty)$
 $\left(\frac{f}{g}\right)(x) = \frac{\sqrt{x}}{x - 5}$
 $\left(\frac{f}{g}\right)(x) = \frac{3 - x^2}{x^2 + 2x - 15}$
 domain: $(-\infty, -5) \cup (-5, 3) \cup (3, \infty)$

domain: $[0,5) \cup (5, \infty)$

41. $(f+g)(x) = 2 + \frac{1}{x} + \frac{1}{x} = 2 + \frac{2}{x} = \frac{2x+2}{x}$

domain: $(-\infty, 0) \cup (0, \infty)$

$(f-g)(x) = 2 + \frac{1}{x} - \frac{1}{x} = 2$

domain: $(-\infty, 0) \cup (0, \infty)$

$(fg)(x) = \left(2 + \frac{1}{x}\right) \left(\frac{1}{x} + 2\right) = \frac{2}{x} + \frac{1}{x^2} + \frac{2}{x} + 2 = \frac{2x+1}{x^2}$

domain: $(-\infty, 0) \cup (0, \infty)$

$\left(\frac{f}{g}\right)(x) = \frac{2 + \frac{1}{x}}{\frac{1}{x} + 2}$

$\left(\frac{g}{f}\right)(x) = \frac{\frac{1}{x}}{2 + \frac{1}{x}} = \frac{1}{2x+1}$

domain: $(-\infty, 0) \cup (0, \infty)$

42. $(f+g)(x) = 6 - \frac{1}{x} + \frac{1}{x} = 6$

domain: $(-\infty, 0) \cup (0, \infty)$

$(f-g)(x) = 6 - \frac{1}{x} - \frac{1}{x} = 6 - \frac{2}{x} = \frac{6x-2}{x}$

domain: $(-\infty, 0) \cup (0, \infty)$

$(fg)(x) = \left(6 - \frac{1}{x}\right) \left(\frac{1}{x} + 6\right) = \frac{6}{x} - \frac{1}{x^2} + \frac{6}{x} + 6 = \frac{6x-1}{x^2}$

domain: $(-\infty, 0) \cup (0, \infty)$

$\left(\frac{f}{g}\right)(x) = \frac{6x - \frac{1}{x}}{\frac{1}{x} + 6} = \frac{6x^2 - 1}{6x + 1}$

$\left(\frac{g}{f}\right)(x) = \frac{\frac{1}{x}}{6x - \frac{1}{x}} = \frac{1}{6x^2 - 1}$

domain: $(-\infty, 0) \cup (0, \infty)$

43. $(f+g)(x) = f(x) + g(x) = \frac{5x+1}{x^2-9} + \frac{4x-2}{x^2-9}$

$= \frac{x^2-9}{x^2-9} \cdot \frac{5x+1}{x^2-9} + \frac{x^2-9}{x^2-9} \cdot \frac{4x-2}{x^2-9} = \frac{9x-1}{x^2-9}$

domain: $(-\infty, -3) \cup (-3, 3) \cup (3, \infty)$

$(f-g)(x) = f(x) - g(x)$

$= \frac{5x+1}{x^2-9} - \frac{4x-2}{x^2-9} = \frac{x^2-9}{x^2-9} \cdot \frac{x+3}{x^2-9} = \frac{x+3}{x^2-9}$

$= \frac{1}{x-3}$

$x-3$

domain: $(-\infty, -3) \cup (-3, 3) \cup (3, \infty)$

$(fg)(x) = f(x) \cdot g(x)$

$= \frac{5x+1}{x^2-9} \cdot \frac{4x-2}{x^2-9}$

$\frac{x^2-9}{x^2-9} \cdot \frac{x^2-9}{x^2-9}$

$= \frac{(5x+1)(4x-2)}{x^2-9}$

domain: $(-\infty, -3) \cup (-3, 3) \cup (3, \infty)$

$5x+1$

$\left(\frac{f}{g}\right)(x) = \frac{x^2-9}{\frac{4x-2}{x^2-9}}$

$\left(\frac{g}{f}\right)(x) = \frac{\frac{4x-2}{x^2-9}}{x-9}$

$= \frac{5x+1}{x^2-9} \cdot \frac{x-9}{4x-2}$

$= \frac{5x+1}{x^2-9} \cdot \frac{x-9}{4x-2}$

$= \frac{5x+1}{4x-2}$

$= \frac{5x+1}{4x-2}$

The domain must exclude -3 , 3 , and any values that make $4x-2=0$.

$4x-2=0$

$4x=2$

$x = \frac{1}{2}$

domain: $(-\infty, -3) \cup (-3, \frac{1}{2}) \cup (\frac{1}{2}, 3) \cup (3, \infty)$

44. $(f + g)(x) = f(x) + g(x)$

$$= \frac{3x+1}{x^2-25} + \frac{2x-4}{x^2-25}$$

$$= \frac{5x-3}{x^2-25}$$
 domain: $(-\infty, -5) \cup (-5, 5) \cup (5, \infty)$
 $(f - g)(x) = f(x) - g(x)$

$$= \frac{3x+1}{x^2-25} - \frac{2x-4}{x^2-25}$$

$$= \frac{x+5}{x^2-25}$$

$$= \frac{1}{x-5}$$

domain: $(-\infty, -5) \cup (-5, 5) \cup (5, \infty)$

$(fg)(x) = f(x) \cdot g(x)$

$$= \frac{3x+1}{x^2-25} \cdot \frac{2x-4}{x^2-25}$$

$$= \frac{(3x+1)(2x-4)}{(x^2-25)^2}$$

domain: $(-\infty, -5) \cup (-5, 5) \cup (5, \infty)$

(f)
$$\frac{3x+1}{x^2-25}$$

 (g)
$$\frac{2x-4}{x^2-25}$$

$$= \frac{3x+1}{x^2-25} \cdot \frac{2x-4}{x^2-25}$$

$$= \frac{3x+1}{2x-4}$$

The domain must exclude -5, 5, and any values that make $2x - 4 = 0$.

$2x - 4 = 0$

$2x = 4$

$x = 2$

domain: $(-\infty, -5) \cup (-5, 2) \cup (2, 5) \cup (5, \infty)$

45. $(f + g)(x) = f(x) + g(x)$

$$= \frac{8x}{x-2} + \frac{6}{x+3}$$

$$= \frac{8x(x+3)}{(x-2)(x+3)} + \frac{6(x-2)}{(x-2)(x+3)}$$

$$= \frac{8x^2 + 24x}{(x-2)(x+3)} + \frac{6x-12}{(x-2)(x+3)}$$

$$= \frac{8x^2 + 30x - 12}{(x-2)(x+3)}$$
 domain: $(-\infty, -3) \cup (-3, 2) \cup (2, \infty)$
 $(f + g)(x) = f(x) - g(x)$

$$= \frac{8x}{x-2} - \frac{6}{x+3}$$

$$= \frac{8x(x+3)}{(x-2)(x+3)} - \frac{6(x-2)}{(x-2)(x+3)}$$

$$= \frac{8x^2 + 18x + 12}{(x-2)(x+3)}$$

domain: $(-\infty, -3) \cup (-3, 2) \cup (2, \infty)$

$(fg)(x) = f(x) \cdot g(x)$

$$= \frac{8x}{x-2} \cdot \frac{6}{x+3}$$

$$= \frac{48x}{(x-2)(x+3)}$$

domain: $(-\infty, -3) \cup (-3, 2) \cup (2, \infty)$

$$\left(\frac{f}{g}\right)(x) = \frac{\frac{8x}{x-2}}{\frac{6}{x+3}}$$

$$= \frac{8x}{x-2} \cdot \frac{x+3}{6}$$

$$= \frac{4x(x+3)}{3(x-2)}$$

The domain must exclude -3, 2, and any values that make $3(x - 2) = 0$.

$3(x - 2) = 0$

$3x - 6 = 0$

$3x = 6$

$x = 2$

domain: $(-\infty, -3) \cup (-3, 2) \cup (2, \infty)$

46. $(f + g)(x) = f(x) + g(x)$

$$\begin{aligned} &= \frac{9x}{x-4} + \frac{7}{x+8} \\ &= \frac{9x(x+8)}{(x-4)(x+8)} + \frac{7(x-4)}{(x-4)(x+8)} \\ &= \frac{9x^2 + 72x}{(x-4)(x+8)} + \frac{7x - 28}{(x-4)(x+8)} \\ &= \frac{9x^2 + 79x - 28}{(x-4)(x+8)} \end{aligned}$$

domain: $(-\infty, -8) \cup (-8, 4) \cup (4, \infty)$

$(f + g)(x) = f(x) - g(x)$

$$\begin{aligned} &= \frac{9x}{x-4} - \frac{7}{x+8} \\ &= \frac{9x(x+8)}{(x-4)(x+8)} - \frac{7(x-4)}{(x-4)(x+8)} \\ &= \frac{9x^2 + 72x}{(x-4)(x+8)} - \frac{7x - 28}{(x-4)(x+8)} \\ &= \frac{9x^2 + 65x + 28}{(x-4)(x+8)} \end{aligned}$$

domain: $(-\infty, -8) \cup (-8, 4) \cup (4, \infty)$

$(fg)(x) = f(x) \cdot g(x)$

$$\begin{aligned} &= \frac{9x}{x-4} \cdot \frac{7}{x+8} \\ &= \frac{63x}{(x-4)(x+8)} \end{aligned}$$

domain: $(-\infty, -8) \cup (-8, 4) \cup (4, \infty)$

$$\begin{aligned} \left| \frac{f}{g} \right| (x) &= \frac{\frac{9x}{x-4}}{\frac{7}{x+8}} \\ &= \frac{9x}{x-4} \cdot \frac{x+8}{7} \\ &= \frac{9x(x+8)}{7(x-4)} \end{aligned}$$

The domain must exclude -8 , 4 , and any values that make $7(x-4) = 0$.

$7(x-4) = 0$

$7x - 28 = 0$

47. $(f + g)(x) = \sqrt{x+4} + \sqrt{x-1}$

domain: $[1, \infty)$

$(f - g)(x) = \sqrt{x+4} - \sqrt{x-1}$

domain: $[1, \infty)$

$(fg)(x) = \sqrt{x+4} \cdot \sqrt{x-1} = \sqrt{x^2 + 3x - 4}$

domain: $[1, \infty)$

$\left(\frac{f}{g} \right) (x) = \frac{\sqrt{x+4}}{\sqrt{x-1}}$

domain: $(1, \infty)$

48. $(f + g)(x) = \sqrt{x+6} + \sqrt{x-3}$
domain: $[3, \infty)$

$(f - g)(x) = \sqrt{x+6} - \sqrt{x-3}$

domain: $[3, \infty)$

$(fg)(x) = \sqrt{x+6} \cdot \sqrt{x-3} = \sqrt{x^2 + 3x - 18}$

domain: $[3, \infty)$

$\left(\frac{f}{g} \right) (x) = \frac{\sqrt{x+6}}{\sqrt{x-3}}$

domain: $(3, \infty)$

49. $(f + g)(x) = \sqrt{x-2} + \sqrt{2-x}$

domain: $\{2\}$

$(f - g)(x) = \sqrt{x-2} - \sqrt{2-x}$

domain: $\{2\}$

$(fg)(x) = \sqrt{x-2} \cdot \sqrt{2-x} = \sqrt{-x^2 + 4x - 4}$

domain: $\{2\}$

$\left| \frac{f}{g} \right| (x) = \frac{\sqrt{x-2}}{\sqrt{2-x}}$

$7x = 28$

$x = 4$

domain: $(-\infty, -8) \cup (-8, 4) \cup (4, \infty)$

()
 domain: \emptyset

50. $(f + g)(x) =$ +
 domain: $\{5\}$

$$\sqrt{x-5} + \sqrt{5-x}$$

$(f - g)(x) =$ -
 domain: $\{5\}$

$$\sqrt{x-5} - \sqrt{5-x}$$

$(fg)(x) = x - 5 \cdot$ =
 domain: $\{5\}$

$$\sqrt{\quad} \sqrt{5-x} \sqrt{-x^2 + 10x - 25}$$

$(\frac{f}{g})(x) =$
 ()
 domain: \emptyset

$$\left| \frac{\sqrt{x-5}}{\sqrt{5-x}} \right|$$

51. $f(x) = 2x$; $g(x) = x + 7$

a. $(f \circ g)(x) = 2(x + 7) = 2x + 14$

b. $(g \circ f)(x) = 2x + 7$

c. $(f \circ g)(2) = 2(2) + 14 = 18$

52. $f(x) = 3x$; $g(x) = x - 5$

a. $(f \circ g)(x) = 3(x - 5) = 3x - 15$

b. $(g \circ f)(x) = 3x - 5$

c. $(f \circ g)(2) = 3(2) - 15 = -9$

53. $f(x) = x + 4$; $g(x) = 2x + 1$

a. $(f \circ g)(x) = (2x + 1) + 4 = 2x + 5$

b. $(g \circ f)(x) = 2(x + 4) + 1 = 2x + 9$

c. $(f \circ g)(2) = 2(2) + 5 = 9$

54. $f(x) = 5x + 2$; $g(x) = 3x - 4$

a. $(f \circ g)(x) = 5(3x - 4) + 2 = 15x - 18$

b. $(g \circ f)(x) = 3(5x + 2) - 4 = 15x + 2$

c. $(f \circ g)(2) = 15(2) - 18 = 12$

55. $f(x) = 4x - 3$; $g(x) = 5x^2 - 2$

a. $(f \circ g)(x) = 4(5x^2 - 2) - 3$
 $= 20x^2 - 11$

b. $(g \circ f)(x) = 5(4x - 3)^2 - 2$
 $= 5(16x^2 - 24x + 9) - 2$
 $= 80x^2 - 120x + 43$

c. $(f \circ g)(2) = 20(2)^2 - 11 = 69$

56. $f(x) = 7x + 1$; $g(x) = 2x^2 - 9$

a. $(f \circ g)(x) = 7(2x^2 - 9) + 1 = 14x^2 - 62$

b. $(g \circ f)(x) = 2(7x + 1)^2 - 9$
 $= 2(49x^2 + 14x + 1) - 9$
 $= 98x^2 + 28x - 7$

c. $(f \circ g)(2) = 14(2)^2 - 62 = -6$

57. $f(x) = x^2 + 2$; $g(x) = x^2 - 2$

a. $(f \circ g)(x) = (x^2 - 2)^2 + 2$
 $= x^4 - 4x^2 + 4 + 2$
 $= x^4 - 4x^2 + 6$

b. $(g \circ f)(x) = (x^2 + 2)^2 - 2$
 $= x^4 + 4x^2 + 4 - 2$
 $= x^4 + 4x^2 + 2$

c. $(f \circ g)(2) = 2^4 - 4(2)^2 + 6 = 6$

58. $f(x) = x^2 + 1$; $g(x) = x^2 - 3$

a. $(f \circ g)(x) = (x^2 - 3)^2 + 1$
 $= x^4 - 6x^2 + 9 + 1$
 $= x^4 - 6x^2 + 10$

b. $(g \circ f)(x) = (x^2 + 1)^2 - 3$
 $= x^4 + 2x^2 + 1 - 3$
 $= x^4 + 2x^2 - 2$

c. $(f \circ g)(2) = 2^4 - 6(2)^2 + 10 = 2$

59. $f(x) = 4 - x$; $g(x) = 2x^2 + x + 5$

a. $(f \circ g)(x) = 4 - (2x^2 + x + 5)$
 $= 4 - 2x^2 - x - 5$
 $= -2x^2 - x - 1$

b. $(g \circ f)(x) = 2(4 - x)^2 + (4 - x) + 5$
 $= 2(16 - 8x + x^2) + 4 - x + 5$
 $= 32 - 16x + 2x^2 + 4 - x + 5$
 $= 2x^2 - 17x + 41$

c. $(f \circ g)(2) = -2(2)^2 - 2 - 1 = -11$

60. $f(x) = 5x - 2; g(x) = -x^2 + 4x - 1$

a. $(f \circ g)(x) = 5(-x^2 + 4x - 1) - 2$
 $= -5x^2 + 20x - 5 - 2$
 $= -5x^2 + 20x - 7$

b. $(g \circ f)(x) = -(5x - 2)^2 + 4(5x - 2) - 1$
 $= -(25x^2 - 20x + 4) + 20x - 8 - 1$
 $= -25x^2 + 20x - 4 + 20x - 8 - 1$
 $= -25x^2 + 40x - 13$

c. $(f \circ g)(2) = -5(2)^2 + 20(2) - 7 = 13$

61. $f(x) = \sqrt{x}; g(x) = x - 1$

a. $(f \circ g)(x) = \sqrt{x-1}$

b. $(g \circ f)(x) = \sqrt{x} - 1$

c. $(f \circ g)(2) = \sqrt{2-1} = \sqrt{1} = 1$

62. $f(x) = \sqrt{x}; g(x) = x + 2$

a. $(f \circ g)(x) = \sqrt{x+2}$

b. $(g \circ f)(x) = \sqrt{x} + 2$

c. $(f \circ g)(2) = \sqrt{2+2} = \sqrt{4} = 2$

63. $f(x) = 2x - 3; g(x) = \frac{x+3}{2}$

a. $(f \circ g)(x) = 2\left(\frac{x+3}{2}\right) - 3$
 $= x + 3 - 3$
 $= x$

b. $(g \circ f)(x) = \frac{(2x-3)+3}{2} = \frac{2x}{2} = x$

c. $(f \circ g)(2) = 2$

64. $f(x) = 6x - 3; g(x) = \frac{x+3}{6}$

a. $(f \circ g)(x) = \left(\frac{x+3}{6}\right) - 3 = x + 3 - 3 = x$

b. $(g \circ f)(x) = \frac{6x-3+3}{6} = \frac{6x}{6} = x$

c. $(f \circ g)(2) = 2$

65. $f(x) = \frac{1}{x}; g(x) = \frac{1}{x}$

a. $(f \circ g)(x) = \frac{1}{\frac{1}{x}} = x$

b. $(g \circ f)(x) = \frac{1}{\frac{1}{x}} = x$

c. $(f \circ g)(2) = 2$

66. $f(x) = \frac{2}{x}; g(x) = \frac{2}{x}$

a. $(f \circ g)(x) = \frac{2}{\frac{2}{x}} = x$

b. $(g \circ f)(x) = \frac{2}{\frac{2}{x}} = x$

c. $(f \circ g)(2) = 2$

67. a. $(f \circ g)(x) = f\left(\frac{1}{x}\right) = \frac{1}{\frac{1}{x} + 3} = \frac{x}{1 + 3x}, x \neq 0$

b. We must exclude 0 because it is excluded from g .
 We must exclude $-\frac{1}{3}$

because it causes the

denominator of $f \circ g$ to be 0.
domain: $(-\infty, -1) \cup (-1, 0) \cup (0, \infty)$.

$$\left(\quad \quad \right) \cup \left(\quad \quad \right)$$

68. a. $f \circ g(x) = f\left(\frac{1}{x}\right) = \frac{5}{\frac{1}{x} + 4} = \frac{5x}{1+4x}$

b. We must exclude 0 because it is excluded from g .

We must exclude $-\frac{1}{4}$ because it causes the denominator of $f \circ g$ to be 0.

domain: $\left(-\infty, -\frac{1}{4}\right) \cup \left(-\frac{1}{4}, 0\right) \cup (0, \infty)$.

69. a. $(f \circ g)(x) = f\left(\frac{4}{x}\right) = \frac{4x^{-1}}{\frac{4}{x} + 1} = \frac{4x}{4x + 1}$

$x \neq -4$

b. We must exclude 0 because it is excluded from g . We must exclude -4 because it causes the denominator of $f \circ g$ to be 0.

domain: $(-\infty, -4) \cup (-4, 0) \cup (0, \infty)$.

70. a. $f \circ g(x) = f\left(\frac{6}{x}\right) = \frac{x^6}{\frac{6}{x} + 5} = \frac{6x^6}{6+5x}$

b. We must exclude 0 because it is excluded from g .

We must exclude $-\frac{6}{5}$ because it causes the

denominator of $f \circ g$ to be 0.
domain: $\left(-\infty, -\frac{6}{5}\right) \cup \left(-\frac{6}{5}, 0\right) \cup (0, \infty)$.

71. a. $f \circ g(x) = f(x-2) = \sqrt{x-2}$

b. The expression under the radical in $f \circ g$ must not be negative.

b. The expression under the radical in $f \circ g$ must not be negative.

$x - 3 \geq 0$

$x \geq 3$

domain: $[3, \infty)$.

73. a. $(f \circ g)(x) = f(\sqrt{-x}) = \left(\frac{1}{\sqrt{-x}}\right)^2 + 4 = 1 - x + 4 = 5 - x$

b. The domain of $f \circ g$ must exclude any values that are excluded from g .

$1 - x \geq 0$

$-x \geq -1$

domain: $(-\infty, 1]$.

74. a. $(f \circ g)(x) = f(\sqrt{2-x}) = \sqrt{2-x} + 1 = 2 - x + 1 = 3 - x$

b. The domain of $f \circ g$ must exclude any values that are excluded from g .

$2 - x \geq 0$

$-x \geq -2$

$x \leq 2$

domain: $(-\infty, 2]$.

75. $f(x) = x^4$ $g(x) = 3x - 1$

76. $f(x) = x^3$; $g(x) = 2x - 5$

77. $f(x) = \sqrt[3]{x}$ $g(x) = x^2 - 9$

78. $f(x) = \sqrt{x}$; $g(x) = 5x^2 + 3$

79. $f(x) = |x|$ $g(x) = 2x - 5$

80. $f(x) = |x|$; $g(x) = 3x - 4$

Chapter 2 Functions and Graphs

$$x - 2 \geq 0$$

$$x \geq 2$$

domain: $[2, \infty)$.

72. a. $f \circ g(x) = f(x-3) = \sqrt{x-3}$

81. $f(x) = \frac{1}{x}$ $g(x) = 2x - 3$

82. $f(x) = \frac{1}{x}$; $g(x) = 4x + 5$

83. $(f + g)(-3) = f(-3) + g(-3) = 4 + 1 = 5$

84. $(g - f)(-2) = g(-2) - f(-2) = 2 - 3 = -1$

85. $(fg)(2) = f(2)g(2) = (-1)(1) = -1$

86. $\left(\frac{g}{f}\right)(3) = \frac{g(3)}{f(3)} = \frac{0}{-3} = 0$

87. The domain of $f + g$ is $[-4, 3]$.

88. The domain of $\frac{f}{g}$ is $(-4, 3)$.

89. The graph of $f + g$

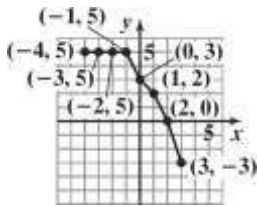

90. The graph of $f - g$

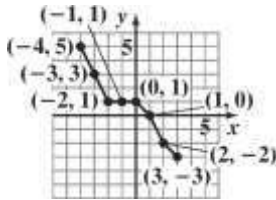

91. $(f \circ g)(-1) = f(g(-1)) = f(-3) = 1$

92. $(f \circ g)(1) = f(g(1)) = f(-5) = 3$

93. $(g \circ f)(0) = g(f(0)) = g(2) = -6$

94. $(g \circ f)(-1) = g(f(-1)) = g(1) = -5$

95. $(f \circ g)(x) = 7$

$$2(x^2 - 3x + 8) - 5 = 7$$

$$2x^2 - 6x + 16 - 5 = 7$$

$$2x^2 - 6x + 11 = 7$$

$$2x^2 - 6x + 4 = 0$$

$$x^2 - 3x + 2 = 0$$

$$(x-1)(x-2) = 0$$

$$x-1 = 0 \text{ or } x-2 = 0$$

$$x = 1 \qquad x = 2$$

96. $(f \circ g)(x) = -5$

$$1 - 2(3x^2 + x - 1) = -5$$

$$1 - 6x^2 - 2x + 2 = -5$$

$$-6x^2 - 2x + 3 = -5$$

$$-6x^2 - 2x + 8 = 0$$

$$3x^2 + x - 4 = 0$$

$$(3x+4)(x-1) = 0$$

$$3x+4 = 0 \text{ or } x-1 = 0$$

$$3x = -4 \qquad x = 1$$

$$x = -\frac{4}{3}$$

97. a. $(M + F)(x) = M(x) + F(x)$

$$= (1.48x + 115.1) + (1.44x + 120.9)$$

$$= 2.92x + 236$$

b. $(M + F)(x) = 2.92x + 236$

$$(M + F)(25) = 2.92(25) + 236$$

$$= 309$$

The total U.S. population in 2010 was 309 million.

c. It is the same.

98. a. $(F - M)(x) = F(x) - M(x)$

$$= (1.44x + 120.9) - (1.48x + 115.1)$$

$$= -0.04x + 5.8$$

b. $(F - M)(x) = -0.04x + 5.8$

$$(F - M)(25) = -0.04(25) + 5.8$$

$$= 4.8$$

In 2010 there were 4.8 million more women than men.

c. The result in part (b) underestimates the actual difference by 0.2 million.

99. $(R - C)(20,000)$
 $= 65(20,000) - (600,000 + 45(20,000))$
 $= -200,000$

The company lost \$200,000 since costs exceeded revenues.

$(R - C)(30,000)$
 $= 65(30,000) - (600,000 + 45(30,000))$
 $= 0$

The company broke even.

$(R - C)(40,000)$
 $= 65(40,000) - (600,000 + 45(40,000))$
 $= 200,000$

The company gained \$200,000 since revenues exceeded costs.

100. a. The slope for f is -0.44 . This is the decrease in profits for the first store for each year after 2012.

b. The slope of g is 0.51 . This is the increase in profits for the second store for each year after 2012.

c. $f + g = -0.44x + 13.62 + 0.51x + 11.14$
 $= 0.07x + 24.76$
 The slope for $f + g$ is 0.07 . This is the profit for the two stores combined for each year after 2012.

101. a. f gives the price of the computer after a \$400 discount. g gives the price of the computer after a 25% discount.

b. $(f \circ g)(x) = 0.75x - 400$
 This models the price of a computer after first a 25% discount and then a \$400 discount.

c. $(g \circ f)(x) = 0.75(x - 400)$
 This models the price of a computer after first a \$400 discount and then a 25% discount.

d. The function $f \circ g$ models the greater discount, since the 25% discount is taken on the regular price first.

102. a. f gives the cost of a pair of jeans for which a \$5 rebate is offered.
 g gives the cost of a pair of jeans that has been discounted 40%.

b. $(f \circ g)(x) = 0.6x - 5$
 The cost of a pair of jeans is 60% of the regular

c. $(g \circ f)(x) = 0.6(x - 5)$
 $= 0.6x - 3$
 The cost of a pair of jeans is 60% of the regular price minus a \$3 rebate.

d. $f \circ g$ because of a \$5 rebate.

103. – 107. Answers will vary.

108. When your trace reaches $x = 0$, the y value disappears because the function is not defined at $x = 0$.

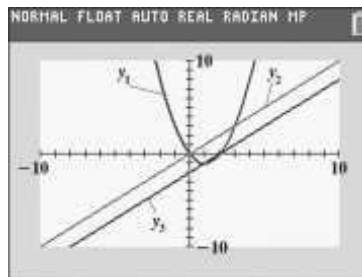

109.

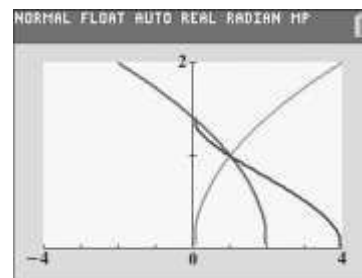

$(f \circ g)(x) = \sqrt{2 - \sqrt{x}}$

The domain of g is $[0, \infty)$.

The expression under the radical in $f \circ g$ must not be negative.

$2 - \sqrt{x} \geq 0$

$-\sqrt{x} \geq -2$

$\sqrt{x} \leq 2$

$x \leq 4$

domain: $[0, 4]$

110. makes sense

111. makes sense

112. does not make sense; Explanations will vary.
 Sample explanation: It is common that $f \circ g$ and

price minus a \$5 rebate.

$g \circ f$ are not the same.

113. does not make sense; Explanations will vary.
Sample explanation: The diagram illustrates

$$g(f(x)) = x^2 + 4.$$

114. false; Changes to make the statement true will vary.

$$\begin{aligned} \text{A sample change is: } (f \circ g)(x) &= f\left(\sqrt{x^2 - 4}\right) \\ &= \left(\sqrt{x^2 - 4} - 4\right) \\ &= x^2 - 4 - 4 \\ &= x^2 - 8 \end{aligned}$$

115. false; Changes to make the statement true will vary.
A sample change is:

$$\begin{aligned} f(x) &= 2x; g(x) = 3x \\ (f \circ g)(x) &= f(g(x)) = f(3x) = 2(3x) = 6x \\ (g \circ f)(x) &= g(f(x)) = g(2x) = 3(2x) = 6x \end{aligned}$$

116. false; Changes to make the statement true will vary.
A sample change is:

$$(f \circ g)(4) = f(g(4)) = f(7) = 5$$

117. true

$$118. (f \circ g)(x) = (f \circ g)(-x)$$

$$\begin{aligned} f(g(x)) &= f(g(-x)) \quad \text{since } g \text{ is even} \\ f(g(x)) &= f(g(x)) \text{ so } f \circ g \text{ is even} \end{aligned}$$

119. Answers will vary.

$$\frac{x-1}{5} - \frac{x+3}{2} = 1 - \frac{x}{4}$$

120.

$$20 \left(\frac{x-1}{5} - \frac{x+3}{2} \right) = 20 \left(1 - \frac{x}{4} \right)$$

$$\begin{aligned} 4(x-1) - 10(x+3) &= 20 - 5x \\ 4x - 4 - 10x - 30 &= 20 - 5x \\ -6x - 34 &= 20 - 5x \\ -6x + 5x &= 20 + 34 \\ -1x &= 54 \\ x &= -54 \end{aligned}$$

The solution set is $\{-54\}$.

121. Let x = the number of bridge crossings at which the costs of the two plans are the same.

$$\begin{array}{l} \text{No Pass} \quad \text{Discount Pass} \\ 6x = 30 + 4x \end{array}$$

$$\begin{aligned} 6x - 4x &= 30 \\ 2x &= 30 \\ x &= 15 \end{aligned}$$

The two plans cost the same for 15 bridge crossings.
The monthly cost is $\$6(15) = \90 .

122. $Ax + By = Cy + D$ By

$$\begin{aligned} -Cy &= D - Ax \quad (B \\ -C) &= D - Ax \\ y &= \frac{D - Ax}{B - C} \end{aligned}$$

123. $\{(4, -2), (1, -1), (1, 1), (4, 2)\}$

The element 1 in the domain corresponds to two elements in the range.
Thus, the relation is not a function.

$$\begin{aligned} 124. \quad x &= \frac{5}{y} + 4 \\ y(x) &= y \left(\frac{5}{y} + 4 \right) \\ &= \left(\begin{array}{l} y \\ y \end{array} \right) \\ xy &= 5 + 4y \\ xy - 4y &= 5 \\ y(x - 4) &= 5 \end{aligned}$$

$$y = \frac{5}{x - 4}$$

125. $x = y^2 - 1$

$$x + 1 = y^2$$

$$\begin{aligned} \sqrt{x+1} &= \sqrt{y^2} \\ \sqrt{x+1} &= y \\ y &= \sqrt{x+1} \end{aligned}$$

Section 2.7

Check Point Exercises

1. $f(g(x)) = 4 \left(\frac{x+7}{4} \right) - 7$
 $\left(4 \right)$
 $= x + 7 - 7$
 $= x$
 $g(f(x)) = \frac{(4x-7)+7}{4}$
 $= \frac{4x-7+7}{4}$
 4
 $= \frac{4x}{4}$
 $= x$
 $f(g(x)) = g(f(x)) = x$

2. $f(x) = 2x + 7$

Replace $f(x)$ with y :

$y = 2x + 7$

Interchange x and y :

$x = 2y + 7$

Solve for y :

$x = 2y + 7$

$x - 7 = 2y$

$\frac{x-7}{2} = y$

2

Replace y with $f^{-1}(x)$:

$f^{-1}(x) = \frac{x-7}{2}$

3. $f(x) = 4x^3 - 1$

Replace $f(x)$ with y :

$y = 4x^3 - 1$

Interchange x and y :

$x = 4y^3 - 1$

Solve for y :

$x = 4y^3 - 1$

$x + 1 = 4y^3$

$\frac{x+1}{4} = y^3$

$\sqrt[3]{\frac{x+1}{4}} = y$

Replace y with $f^{-1}(x)$:

Alternative form for answer:

$f(x)^{-1} = \sqrt[3]{\frac{x+1}{4}} = \frac{\sqrt[3]{x+1}}{\sqrt[3]{4}}$
 $= \frac{\sqrt[3]{x+1} \cdot \sqrt[3]{2}}{\sqrt[3]{4} \cdot \sqrt[3]{2}} = \frac{\sqrt[3]{2x+2}}{\sqrt[3]{8}}$
 $= \frac{\sqrt[3]{2x+2}}{2}$

4. $f(x) = \frac{x+1}{x-5}, x \neq 5$

Replace $f(x)$ with y :

$y = \frac{x+1}{x-5}$

Interchange x and y :

$x = \frac{y+1}{y-5}$

Solve for y :

$x = \frac{y+1}{y-5}$

$x(y-5) = y+1$

$xy - 5x = y + 1$

$xy - y = 5x + 1$

$y(x-1) = 5x + 1$

$y = \frac{5x+1}{x-1}$

Replace y with $f^{-1}(x)$:

$f^{-1}(x) = \frac{5x+1}{x-1}$

5. The graphs of (b) and (c) pass the horizontal line test and thus have an inverse.

6. Find points of f^{-1} .

$f(x)$	$f^{-1}(x)$
$(-2, -2)$	$(-2, -2)$
$(-1, 0)$	$(0, -1)$
$(1, 2)$	$(2, 1)$

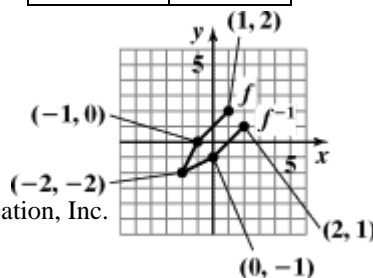

$$f(x) = \sqrt[3]{\frac{x+1}{4}}$$

7. $f(x) = x^2 + 1$
 Replace $f(x)$ with y :

$$y = x^2 + 1$$

Interchange x and y :

$$x = y^2 + 1$$

Solve for y :

$$x = y^2 + 1$$

$$x - 1 = y^2$$

$$\sqrt{x-1} = y$$

Replace y with $f^{-1}(x)$:
 $f^{-1}(x) = \sqrt{x-1}$

f

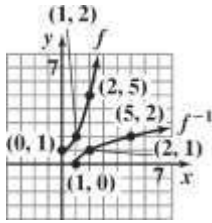

Concept and Vocabulary Check 2.7

1. inverse
2. x ; x
3. horizontal; one-to-one
4. $y = x$

Exercise Set 2.7

1. $f(x) = 4x$; $g(x) = \frac{x}{4}$

$$f(g(x)) = 4 \left(\frac{x}{4} \right) = x$$

$$g(f(x)) = \frac{4x}{4} = x$$

f and g are inverses.

2. $f(x) = 6x$; $g(x) = \frac{x}{6}$

3. $f(x) = 3x + 8$; $g(x) = \frac{x-8}{3}$

$$f(g(x)) = 3 \left(\frac{x-8}{3} \right) + 8 = x - 8 + 8 = x$$

$$g(f(x)) = \frac{(3x+8)-8}{3} = \frac{3x}{3} = x$$

f and g are inverses.

4. $f(x) = 4x + 9$; $g(x) = \frac{x-9}{4}$

$$f(g(x)) = 4 \left(\frac{x-9}{4} \right) + 9 = x - 9 + 9 = x$$

f and g are inverses.

5. $f(x) = 5x - 9$; $g(x) = \frac{x+5}{9}$

$$f(g(x)) = 5 \left(\frac{x+5}{9} \right) - 9 = \frac{5x+25}{9} - 9 = \frac{5x-56}{9}$$

$$g(f(x)) = \frac{5x-9+5}{9} = \frac{5x-4}{9}$$

f and g are not inverses.

6. $f(x) = 3x - 7$; $g(x) = \frac{x+3}{7}$

$$f(g(x)) = 3 \left(\frac{x+3}{7} \right) - 7 = \frac{3x+9}{7} - 7 = \frac{3x-40}{7}$$

$$g(f(x)) = \frac{3x-7+3}{7} = \frac{3x-4}{7}$$

f and g are not inverses.

7. $f(x) = \frac{3}{x-4}$; $g(x) = \frac{3}{x} + 4$

$$f(g(x)) = \frac{3}{\frac{3}{x} + 4 - 4} = \frac{3}{\frac{3}{x}} = x$$

$$g(f(x)) = \frac{3}{\frac{3}{x-4}} + 4 = x$$

Chapter 2 Functions and Graphs

$$f(g(x)) = 6\left(\frac{x}{6}\right) = x$$

$$g(f(x)) = \frac{6x}{6} = x$$

f and g are inverses.

$$\left(\frac{x}{3}\right)$$
$$= x - 4 + 4$$

$$= x$$

f and g are inverses.

$$8. \quad f(x) = \frac{2}{x-5}; g(x) = \frac{2}{x} + 5$$

$$f(g(x)) = \frac{2}{\left(\frac{2}{x} + 5\right) - 5} = \frac{2x}{2} = x$$

$$g(f(x)) = \frac{2}{\frac{2}{x-5}} + 5 = 2\left(\frac{x-5}{2}\right) + 5 = x - 5 + 5 = x$$

f and g are inverses.

$$9. \quad f(x) = -x; g(x) = -x$$

$$f(g(x)) = -(-x) = x$$

$$g(f(x)) = -(-x) = x$$

f and g are inverses.

$$10. \quad f(x) = \sqrt[3]{x-4}; g(x) = x^3 + 4$$

$$f(g(x)) = \sqrt[3]{x^3 + 4 - 4} = \sqrt[3]{x^3} = x$$

$$g(f(x)) = \left(\sqrt[3]{x-4}\right)^3 + 4 = x - 4 + 4 = x$$

f and g are inverses.

$$11. \quad \text{a.} \quad f(x) = x + 3$$

$$y = x + 3$$

$$x = y + 3$$

$$y = x - 3$$

$$f^{-1}(x) = x - 3$$

$$\text{b.} \quad f(f^{-1}(x)) = x - 3 + 3 = x$$

$$f^{-1}(f(x)) = x + 3 - 3 = x$$

$$12. \quad \text{a.} \quad f(x) = x + 5$$

$$y = x + 5$$

$$x = y + 5$$

$$y = x - 5$$

$$f^{-1}(x) = x - 5$$

$$\text{b.} \quad f(f^{-1}(x)) = x - 5 + 5 = x$$

$$f^{-1}(f(x)) = x + 5 - 5 = x$$

$$13. \quad \text{a.} \quad f(x) = 2x$$

$$y = 2x$$

$$x = \frac{y}{2}$$

$$y = \frac{x}{2}$$

$$f^{-1}(x) = \frac{x}{2}$$

$$f^{-1}(x) = \frac{x}{2}$$

$$\text{b.} \quad f(f^{-1}(x)) = 2\left(\frac{x}{2}\right) = x$$

$$f^{-1}(f(x)) = \frac{2x}{2} = x$$

$$14. \quad \text{a.} \quad f(x) = 4x$$

$$y = 4x$$

$$x = \frac{y}{4}$$

$$y = \frac{x}{4}$$

$$f^{-1}(x) = \frac{x}{4}$$

$$\text{b.} \quad f(f^{-1}(x)) = 4\left(\frac{x}{4}\right) = x$$

$$f^{-1}(f(x)) = \frac{x}{4} = x$$

$$15. \quad \text{a.} \quad f(x) = 2x + 3$$

$$y = 2x + 3$$

$$x = \frac{y - 3}{2}$$

$$x - 3 = \frac{y - 3}{2}$$

$$y = \frac{x - 3}{2}$$

$$f^{-1}(x) = \frac{x - 3}{2}$$

$$\text{b.} \quad f(f^{-1}(x)) = 2\left(\frac{x - 3}{2}\right) + 3$$

$$= x - 3 + 3$$

$$= x$$

$$f^{-1}(f(x)) = \frac{2x + 3 - 3}{2} = \frac{2x}{2} = x$$

$$16. \quad \text{a.} \quad f(x) = 3x - 1$$

$$y = 3x - 1$$

$$x = \frac{y + 1}{3}$$

$$x + 1 = \frac{y + 1}{3}$$

$$y = \frac{x + 1}{3}$$

$$f^{-1}(x) = \frac{x + 1}{3}$$

$$\text{b.} \quad f(f^{-1}(x)) = 3\left(\frac{x + 1}{3}\right) - 1 = x + 1 - 1 = x$$

Chapter 2 Functions and Graphs

$$f^{-1}(f(x)) = \frac{3x}{3}$$
$$\frac{-1+1}{3} = \frac{3x}{3} = x$$

$$\begin{aligned}
 17. \quad \text{a.} \quad & f(x) = x^3 + 2 \\
 & y = x^3 + 2 \\
 & x = y^3 + 2 \\
 & x - 2 = y^3 \\
 & y = \sqrt[3]{x-2} \\
 & f^{-1}(x) = \sqrt[3]{x-2}
 \end{aligned}$$

$$\begin{aligned}
 \text{b.} \quad & f(f^{-1}(x)) = \left(\sqrt[3]{x-2}\right)^3 + 2 \\
 & = x - 2 + 2
 \end{aligned}$$

$$f^{-1}(f(x)) = \sqrt[3]{x^3 + 2 - 2} = \sqrt[3]{x^3} = x$$

$$\begin{aligned}
 18. \quad \text{a.} \quad & f(x) = x^3 - 1 \\
 & y = x^3 - 1 \\
 & x = y^3 - 1 \\
 & x + 1 = \sqrt[3]{y^3} \\
 & y = \sqrt[3]{x+1} \\
 & y = \sqrt[3]{x+1}
 \end{aligned}$$

$$\begin{aligned}
 \text{b.} \quad & f(f^{-1}(x)) = \left(\sqrt[3]{x+1}\right)^3 - 1 \\
 & = x + 1 - 1 \\
 & = x
 \end{aligned}$$

$$f^{-1}(f(x)) = \sqrt[3]{x^3 - 1 + 1} = \sqrt[3]{x^3} = x$$

$$\begin{aligned}
 19. \quad \text{a.} \quad & f(x) = (x+2)^3 \\
 & y = (x+2)^3 \\
 & x = (y+2)^3 \\
 & \sqrt[3]{x} = y + 2 \\
 & y = \sqrt[3]{x} - 2 \\
 & f^{-1}(x) = \sqrt[3]{x} - 2
 \end{aligned}$$

$$\begin{aligned}
 \text{b.} \quad & f(f^{-1}(x)) = \left(\sqrt[3]{x} - 2 + 2\right)^3 = \left(\sqrt[3]{x}\right)^3 = x \\
 & f^{-1}(f(x)) = \sqrt[3]{(x+2)^3} - 2 \\
 & = x + 2 - 2 \\
 & = x
 \end{aligned}$$

$$\begin{aligned}
 20. \quad \text{a.} \quad & f(x) = (x-1)^3 \\
 & y = (x-1)^3 \\
 & x = (y-1)^3 \\
 & \sqrt[3]{x} = y - 1 \\
 & \sqrt[3]{y} = \sqrt[3]{x} + 1
 \end{aligned}$$

$$\begin{aligned}
 \text{b.} \quad & f(f^{-1}(x)) = \left(\sqrt[3]{x} + 1 - 1\right)^3 = \left(\sqrt[3]{x}\right)^3 = x \\
 & f^{-1}(f(x)) = \sqrt[3]{(x-1)^3} + 1 = x - 1 + 1 = x
 \end{aligned}$$

$$\begin{aligned}
 21. \quad \text{a.} \quad & f(x) = \frac{1}{x} \\
 & y = \frac{1}{x} \\
 & x = \frac{1}{y} \\
 & xy = \frac{1}{1} \\
 & y = \frac{x}{1} \\
 & f^{-1}(x) = \frac{1}{x}
 \end{aligned}$$

$$\begin{aligned}
 \text{b.} \quad & f(f^{-1}(x)) = \frac{1}{\frac{1}{x}} = x \\
 & f^{-1}(f(x)) = \frac{\frac{1}{x}}{\frac{1}{x}} = x
 \end{aligned}$$

$$\begin{aligned}
 22. \quad \text{a.} \quad & f(x) = \frac{2}{x} \\
 & y = \frac{2}{x} \\
 & x = \frac{2}{y} \\
 & xy = \frac{2}{2}
 \end{aligned}$$

$$\begin{aligned}
 \text{b.} \quad & y = \frac{x}{2} \\
 & f^{-1}(x) = \frac{2}{x} \\
 & f^{-1}(f(x)) = \frac{2}{\frac{2}{x}} = 2 \cdot \frac{x}{2} = x \\
 & f^{-1}(f(x)) = \frac{2}{\frac{2}{x}} = 2 \cdot \frac{x}{2} = x
 \end{aligned}$$

23. a. $f(x) = \sqrt{x}$
 $y = \sqrt{x}$
 $x = \sqrt{y}$
 $y = x^2$
 $f^{-1}(x) = x^2, x \geq 0$

b. $f(f^{-1}(x)) = \sqrt{x^2} = |x| = x$ for $x \geq 0$.
 $f^{-1}(f(x)) = (\sqrt{x})^2 = x$

24. a. $f(x) = \sqrt[3]{x}$
 $y = \sqrt[3]{x}$
 $x = \sqrt[3]{y}$
 $y = x^3$
 $f^{-1}(x) = x^3$

b. $f(f^{-1}(x)) = \sqrt[3]{x^3} = x$
 $f^{-1}(f(x)) = (\sqrt[3]{x})^3 = x$

25. a. $f(x) = \frac{x+4}{x-2}$
 $y = \frac{x+4}{x-2}$
 $x = \frac{y+4}{y-2}$
 $xy - 2x = y + 4$
 $xy - y = 2x + 4$
 $y(x-1) = 2x + 4$
 $\frac{2x+4}{x-1}$

$$y = \frac{2x+4}{x-1}$$

$$f^{-1}(x) = \frac{2x+4}{x-1}, x \neq 1$$

b. $f(f^{-1}(x)) = \frac{\frac{2x+4}{x-1} + 4}{\frac{2x+4}{x-1} - 2}$
 $= \frac{2x+4+4(x-1)}{2x+4-2(x-1)}$
 $= \frac{6x}{6}$
 $= x$
 $f^{-1}(f(x)) = \frac{2(\frac{x+4}{x-2}) + 4}{\frac{x+4}{x-2} - 1}$

$$= \frac{2x+8+4(x-2)}{x+4-(x-2)}$$

$$= \frac{6x}{6}$$

$$= x$$

26. a. $f(x) = \frac{x+5}{x-6}$
 $y = \frac{x+5}{x-6}$
 $x = \frac{y+5}{y-6}$
 $xy - 6x = y + 5$
 $xy - y = 6x + 5$
 $y(x-1) = 6x + 5$
 $y = \frac{6x+5}{x-1}$
 $f^{-1}(x) = \frac{6x+5}{x-1}, x \neq 1$

$$x - 1$$

$$\begin{aligned} \text{b. } f(f^{-1}(x)) &= \frac{\frac{6x+5}{x-1} + 5}{\frac{6x+5}{x-1} - 6} \\ &= \frac{6x+5+5(x-1)}{6x+5-6(x-1)} \\ &= \frac{11x}{11} \\ &= x \end{aligned}$$

$$\begin{aligned} f^{-1}(f(x)) &= \frac{\frac{6\left(\frac{x+5}{-1}\right) + 5}{\frac{x+5}{-1} - 1}}{x-6} \\ &= \frac{6x+30+5(x-6)}{x+5-(x-6)} \\ &= \frac{11x}{11} \\ &= x \end{aligned}$$

$$\begin{aligned} \text{27. a. } (f)x &= \frac{2x+1}{x-3} \\ y &= \frac{2x+1}{x-3} \\ x &= \frac{2y+1}{y-3} \\ x(y-3) &= 2y+1 \\ xy-3x &= 2y+1 \\ xy-2y &= 3x+1 \\ y(x-2) &= 3x+1 \\ y &= \frac{3x+1}{x-2} \end{aligned}$$

$$f^{-1}(x) = \frac{3x+1}{x-2}$$

$$\begin{aligned} \text{b. } f(f^{-1}(x)) &= \frac{2\left(\frac{3x+1}{x-2}\right) + 1}{\frac{3x+1}{x-2} - 3} \\ &= \frac{2(3x+1) + x - 2}{3x+1 - 3x + 6} \\ &= \frac{7x}{7} = x \end{aligned}$$

$$\begin{aligned} f^{-1}(f(x)) &= \frac{3\left(\frac{2x+1}{x-3}\right) + 1}{\frac{2x+1}{x-3} - 2} \\ &= \frac{3(2x+1) + x - 3}{2x+1 - 2(x-3)} \\ &= \frac{6x+3+x-3}{2x+1-2x+6} = \frac{7x}{7} = x \end{aligned}$$

$$\begin{aligned} \text{28. a. } f(x) &= \frac{2x-3}{x+1} \\ y &= \frac{2x-3}{x+1} \\ x &= \frac{2y-3}{y+1} \\ xy+x &= 2y-3 \\ y(x-2) &= -x-3 \\ y &= \frac{-x-3}{x-2} \\ f^{-1}(x) &= \frac{-x-3}{x-2}, \quad x \neq 2 \end{aligned}$$

$$\begin{aligned} \text{b. } f(f^{-1}(x)) &= \frac{2\left(\frac{-x-3}{x-2}\right) - 3}{\frac{-x-3}{x-2} + 1} \\ &= \frac{-2x-6-3x+6}{-x-3+x-2} = \frac{-5x}{-5} = x \\ f^{-1}(f(x)) &= \frac{-\left(\frac{2x-3}{x+1}\right) - 3}{\frac{2x-3}{x+1} - 2} \\ &= \frac{-2x+3-3x-3}{2x-3-2x-2} = \frac{-5x}{-5} = x \end{aligned}$$

29. The function fails the horizontal line test, so it does not have an inverse function.

30. The function passes the horizontal line test, so it does

have an inverse function.

31. The function fails the horizontal line test, so it does not have an inverse function.
32. The function fails the horizontal line test, so it does not have an inverse function.
33. The function passes the horizontal line test, so it does have an inverse function.
34. The function passes the horizontal line test, so it does have an inverse function.

35.

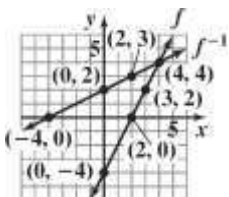

36.

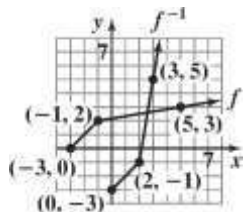

37.

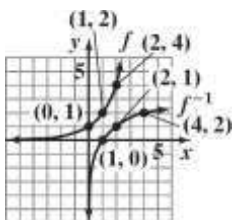

38.

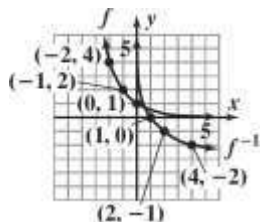

39. a. $f(x) = 2x - 1$
 $y = 2x - 1$
 $x = 2y - 1$
 $x + 1 = 2y$
 $\frac{x+1}{2} = y$
 $f^{-1}(x) = \frac{x+1}{2}$

b.

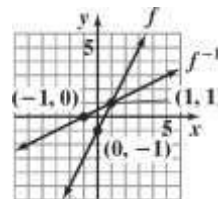

- c. domain of $f : (-\infty, \infty)$
 range of $f : (-\infty, \infty)$
 domain of $f^{-1} : (-\infty, \infty)$
 range of $f^{-1} : (-\infty, \infty)$

40. a. $f(x) = 2x - 3$
 $y = 2x - 3$
 $x = 2y - 3$
 $x + 3 = 2y$
 $\frac{x+3}{2} = y$
 $f^{-1}(x) = \frac{x+3}{2}$

b.

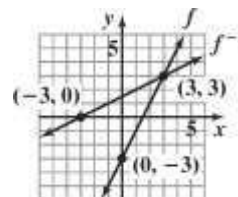

- c. domain of $f : (-\infty, \infty)$
 range of $f : (-\infty, \infty)$
 domain of $f^{-1} : (-\infty, \infty)$
 range of $f^{-1} : (-\infty, \infty)$

41. a. $f(x) = x^2 - 4y$
 $= x^2 - 4x$
 $= y^2 - 4$
 $x + 4 = y^2$
 $\sqrt{x+4} = y$
 $f^{-1}(x) = \sqrt{x+4}$

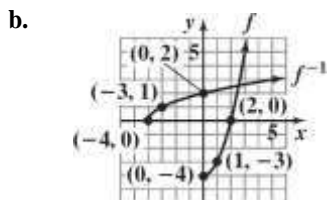

c. domain of $f: [0, \infty)$
 range of $f: [-4, \infty)$

domain of $f^{-1}: [-4, \infty)$
 range of $f^{-1}: [0, \infty)$

42. a. $f(x) = x^2 - 1$
 $y = x^2 - 1$
 $x = y^2 - 1$
 $x + 1 = y^2$
 $-\sqrt{x+1} = y$
 $f^{-1}(x) = -\sqrt{x+1}$

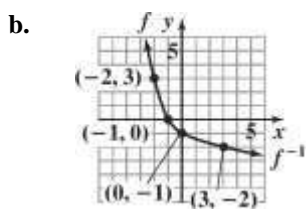

c. domain of $f: (-\infty, 0]$
 range of $f: [-1, \infty)$
 domain of $f^{-1}: [-1, \infty)$
 range of $f^{-1}: (-\infty, 0]$

43. a. $f(x) = (x-1)^2$
 $y = (x-1)^2$
 $x = (y-1)^2$
 $-\sqrt{x} = y - 1$
 $-\sqrt{x} + 1 = y$
 $f^{-1}(x) = 1 - \sqrt{x}$

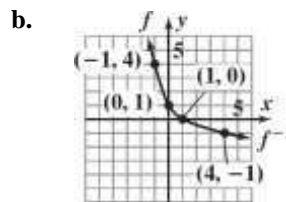

c. domain of $f: (-\infty, 1]$
 range of $f: [0, \infty)$
 domain of $f^{-1}: [0, \infty)$
 range of $f^{-1}: (-\infty, 1]$

44. a. $f(x) = (x-1)^2$
 $y = (x-1)^2$
 $x = (y-1)^2$

$\sqrt{x} = y - 1$
 $\sqrt{x} + 1 = y$
 $f^{-1}(x) = 1 + \sqrt{x}$

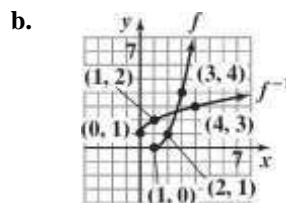

c. domain of $f: [1, \infty)$
 range of $f: [0, \infty)$
 domain of $f^{-1}: [0, \infty)$
 range of $f^{-1}: [1, \infty)$

45. a. $f(x) = x^3 - 1$
 $y = x^3 - 1$
 $x = y^3 - 1$
 $x + 1 = y^3$

$\sqrt[3]{x+1} = y$
 $f^{-1}(x) = \sqrt[3]{x+1}$

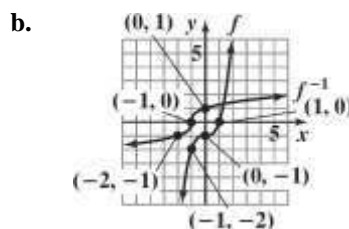

- c. domain of $f: (-\infty, \infty)$
 range of $f: (-\infty, \infty)$
 domain of $f^{-1}: (-\infty, \infty)$
 range of $f^{-1}: (-\infty, \infty)$

46. a. $f(x) = x^3 + 1$
 $y = x^3 + 1$
 $x = y^3 + 1$
 $x - 1 = y^3$
 $\sqrt[3]{x - 1} = y$
 $f^{-1}(x) = \sqrt[3]{x - 1}$

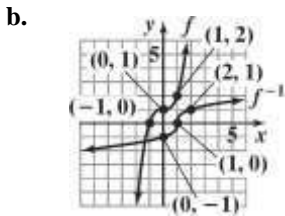

- c. domain of $f: (-\infty, \infty)$
 range of $f: (-\infty, \infty)$
 domain of $f^{-1}: (-\infty, \infty)$
 range of $f^{-1}: (-\infty, \infty)$

47. a. $f(x) = (x + 2)^3$
 $y = (x + 2)^3$
 $x = (y + 2)^3$
 $\sqrt[3]{x} = y + 2$
 $\sqrt[3]{x} - 2 = y$
 $f^{-1}(x) = \sqrt[3]{x} - 2$

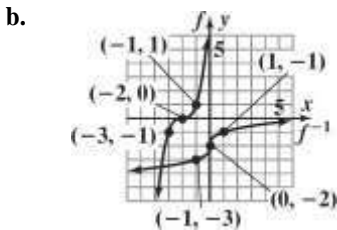

- c. domain of $f: (-\infty, \infty)$
 range of $f: (-\infty, \infty)$
 domain of $f^{-1}: (-\infty, \infty)$
 range of $f^{-1}: (-\infty, \infty)$

48. a. $f(x) = (x - 2)^3$
 $y = (x - 2)^3$
 $x = (y - 2)^3$
 $\sqrt[3]{x} = y - 2$
 $\sqrt[3]{x} + 2 = y$
 $f^{-1}(x) = \sqrt[3]{x} + 2$

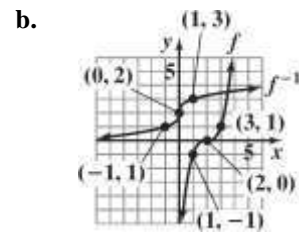

- c. domain of $f: (-\infty, \infty)$
 range of $f: (-\infty, \infty)$
 domain of $f^{-1}: (-\infty, \infty)$
 range of $f^{-1}: (-\infty, \infty)$

49. a. $f(x) = \sqrt{x - 1}$
 $y = \sqrt{x - 1}$
 $x = \sqrt{y - 1}$

$$x^2 = y - 1$$

$$x^2 + 1 = y$$

$$f^{-1}(x) = x^2 + 1$$

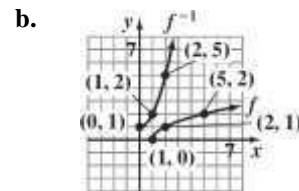

- c. domain of $f: [1, \infty)$
 range of $f: [0, \infty)$
 domain of $f^{-1}: [0, \infty)$
 range of $f^{-1}: [1, \infty)$

50. a. $f(x) = \sqrt{x} + 2$
 $y = \sqrt{x} + 2$
 $\sqrt{y} = x + 2$
 $x - 2 = \sqrt{y}$

$$(x - 2)^2 = y$$

$$f^{-1}(x) = (x - 2)^2$$

b.

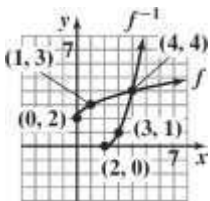

c. domain of $f: [0, \infty)$
 range of $f: [2, \infty)$
 domain of $f^{-1}: [2, \infty)$

range of $f^{-1}: [0, \infty)$

51. a.

$$f(x) = \sqrt[3]{x} + 1$$

$$y = \sqrt[3]{x} + 1$$

$$x = \sqrt[3]{y} + 1$$

$$x - 1 = \sqrt[3]{y}$$

$$(x - 1)^3 = y$$

$$f^{-1}(x) = (x - 1)^3$$

b.

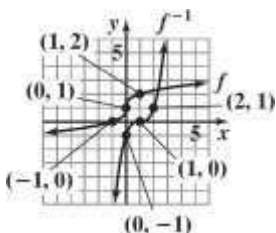

c. domain of $f: (-\infty, \infty)$
 range of $f: (-\infty, \infty)$
 domain of $f^{-1}: (-\infty, \infty)$

range of $f^{-1}: (-\infty, \infty)$

52. a.

$$f(x) = \sqrt[3]{x-1}$$

$$y = \sqrt[3]{x-1}$$

$$x = \sqrt[3]{y-1}$$

$$x^3 = y - 1$$

$$x^3 + 1 = y$$

$$f^{-1}(x) = x^3 + 1$$

b.

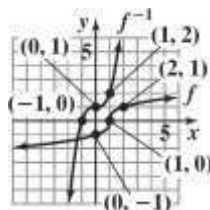

c. domain of $f: (-\infty, \infty)$
 range of $f: (-\infty, \infty)$
 domain of $f^{-1}: (-\infty, \infty)$
 range of $f^{-1}: (-\infty, \infty)$

53. $f(g(1)) = f(1) = 5$

54. $f(g(4)) = f(2) = -1$

55. $(g \circ f)(-1) = g(f(-1)) = g(1) = 1$

56. $(g \circ f)(0) = g(f(0)) = g(4) = 2$

57. $f^{-1}(g(10)) = f^{-1}(-1) = 2$, since $f(2) = -1$.

58. $f^{-1}(g(1)) = f^{-1}(1) = -1$, since $f(-1) = 1$.

59. $(f \circ g)(0) = f(g(0))$
 $= f(4 \cdot 0 - 1)$
 $= f(-1) = 2(-1) - 5 = -7$

60. $(g \circ f)(0) = g(f(0))$
 $= g(2 \cdot 0 - 5)$
 $= g(-5) = 4(-5) - 1 = -21$

61. Let $f^{-1}(1) = x$. Then

$$f(x) = 1$$

$$2x - 5 = 1$$

$$2x = 6$$

$$x = 3$$

Thus, $f^{-1}(1) = 3$

62. Let $g^{-1}(7) = x$. Then

$$g(x) = 7$$

$$4x - 1 = 7$$

$$4x = 8$$

$$x = 2$$

Thus, $g^{-1}(7) = 2$

$$\begin{aligned}
 63. \quad g(f[h(1)]) &= g(f[1^2 + 1 + 2]) \\
 &= g(f(4)) \\
 &= g(2 \cdot 4 - 5) \\
 &= g(3) \\
 &= 4 \cdot 3 - 1 = 11
 \end{aligned}$$

$$\begin{aligned}
 64. \quad f(g[h(1)]) &= f(g[1^2 + 1 + 2]) \\
 &= f(g(4)) \\
 &= f(4 \cdot 4 - 1) \\
 &= f(15) \\
 &= 2 \cdot 15 - 5 = 25
 \end{aligned}$$

65. a. {(Zambia, 4.2), (Colombia, 4.5), (Poland, 3.3), (Italy, 3.3), (United States, 2.5)}
- b. {(4.2, Zambia), (4.5, Colombia), (3.3, Poland), (3.3, Italy), (2.5, United States)}
- f is not a one-to-one function because the inverse of f is not a function.

66. a. {(Zambia, - 7.3), (Colombia, - 4.5), (Poland, - 2.8), (Italy, - 2.8), (United States, - 1.9)}
- b. {(- 7.3, Zambia), (- 4.5, Colombia), (- 2.8, Poland), (- 2.8, Italy), (- 1.9, United States)}
- g is not a one-to-one function because the inverse of g is not a function.

67. a. It passes the horizontal line test and is one-to-one.
- b. $f^{-1}(0.25) = 15$ If there are 15 people in the room, the probability that 2 of them have the same birthday is 0.25.
 $f^{-1}(0.5) = 21$ If there are 21 people in the room, the probability that 2 of them have the same birthday is 0.5.
 $f^{-1}(0.7) = 30$ If there are 30 people in the room, the probability that 2 of them have the same birthday is 0.7.

68. a. This function fails the horizontal line test. Thus, this function does not have an inverse.
- b. The average happiness level is 3 at 12 noon and at 7 p.m. These values can be represented as (12, 3) and (19, 3).
- c. The graph does not represent a one-to-one function. (12, 3) and (19, 3) are an example of two x -values that correspond to the same y -value.

$$\begin{aligned}
 69. \quad f(g(x)) &= 5 \left\lfloor 9 \left\lceil \frac{x}{5} \right\rceil - 32 \right\rfloor + 32 \\
 &= x - 32 + 32
 \end{aligned}$$

$$\begin{aligned}
 g(f(x)) &= 5 \left\lceil \left\lfloor \frac{x}{5} \right\rfloor - 32 \right\rceil - 32 \\
 &= x + 32 - 32 \\
 &= x
 \end{aligned}$$

f and g are inverses.

70. – 75. Answers will vary.

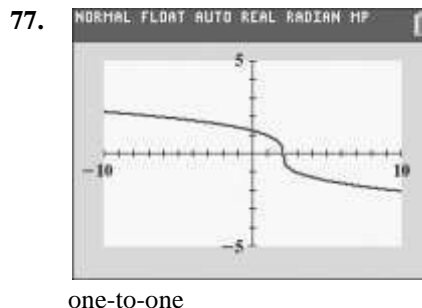
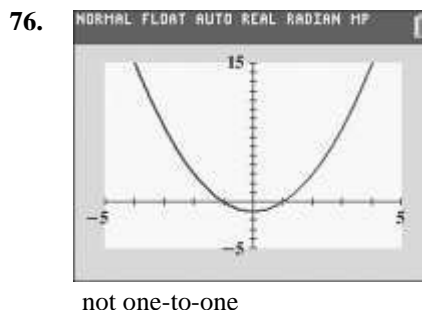

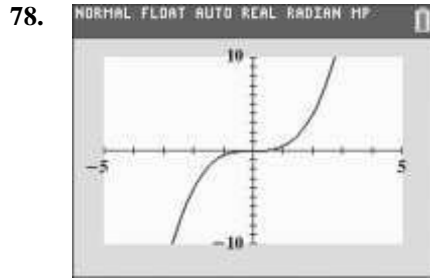

one-to-one

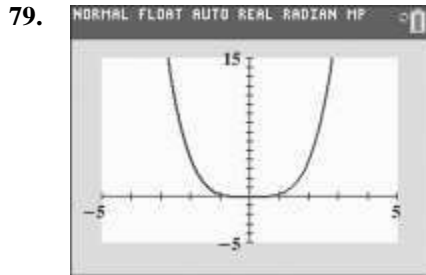

not one-to-one

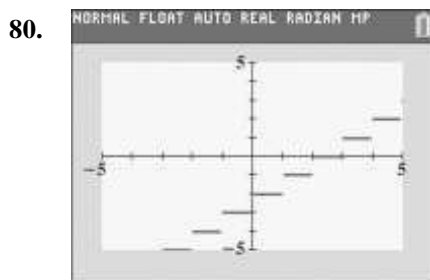

not one-to-one

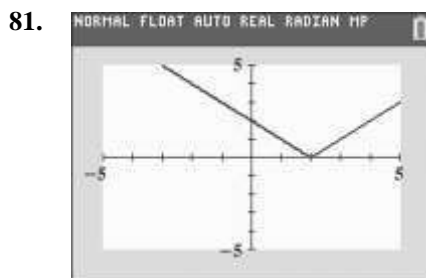

not one-to-one

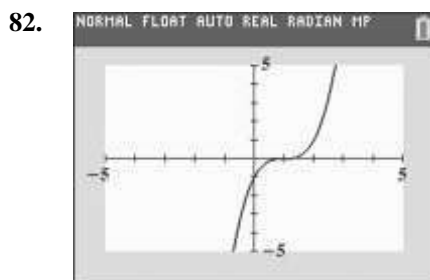

one-to-one

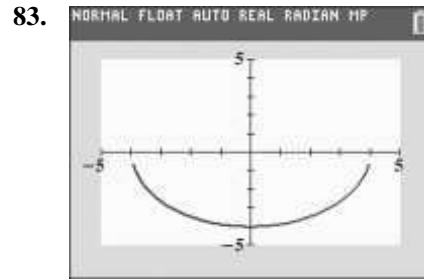

not one-to-one

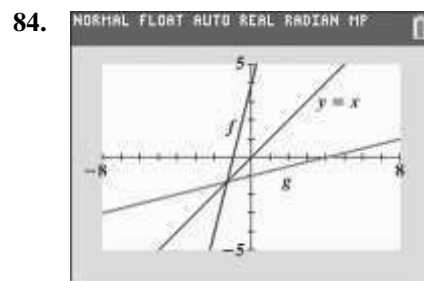

f and g are inverses

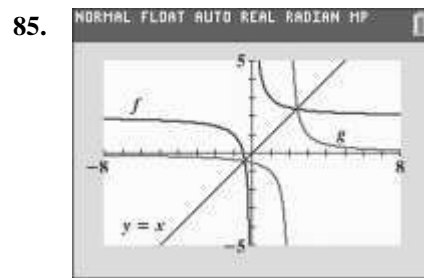

f and g are inverses

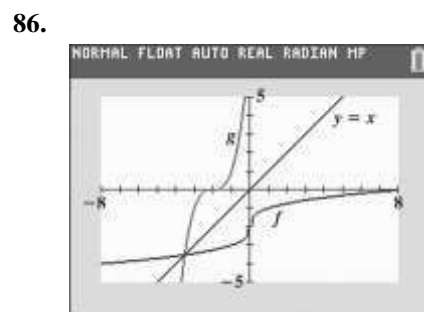

f and g are inverses

87. makes sense

88. makes sense

89. makes sense

90. does not make sense; Explanations will vary.
Sample explanation: The vertical line test is used to determine if a relation is a function, but does not tell us if a function is one-to-one.

91. false; Changes to make the statement true will vary. A sample change is: The inverse is $\{(4,1), (7, 2)\}$.

92. false; Changes to make the statement true will vary. A sample change is: $f(x) = 5$ is a horizontal line, so it does not pass the horizontal line test.

93. false; Changes to make the statement true will vary.

A sample change is: $f^{-1}(x) = \frac{x}{3}$.

94. true

95. $(f \circ g)(x) = 3(x + 5) = 3x + 15$.

$$y = 3x + 15$$

$$x = 3y + 15$$

$$y = \frac{x - 15}{3}$$

$$(f \circ g)^{-1}(x) = \frac{x - 15}{3}$$

$$g(x) = x + 5$$

$$y = x + 5$$

$$x = y + 5$$

$$y = x - 5$$

$$g^{-1}(x) = x - 5$$

$$f(x) = 3x$$

$$y = 3x$$

$$x = 3y$$

$$y = \frac{x}{3}$$

$$f^{-1}(x) = \frac{x}{3}$$

$$(g^{-1} \circ f^{-1})(x) = \frac{x}{3} - 5 = \frac{x - 15}{3}$$

96. $f(x) = \frac{3x - 2}{5x - 3}$

$$5x - 3$$

$$y = \frac{3x - 2}{5x - 3}$$

$$x = \frac{3y - 2}{5y - 3}$$

$$x(5y - 3) = 3y - 2$$

$$5xy - 3x = 3y - 2$$

$$5xy - 3y = 3x - 2$$

$$y(5x - 3) = 3x - 2$$

$$y = \frac{3x - 2}{5x - 3}$$

$$f^{-1}(x) = \frac{3x - 2}{5x - 3}$$

$$5x - 3$$

Note: An alternative approach is to show that

$$(f \circ f)(x) = x.$$

97. No, there will be 2 times when the spacecraft is at the same height, when it is going up and when it is coming down.

98. $8 + f^{-1}(x - 1) = 10$

$$f^{-1}(x - 1) = 2$$

$$f(2) = x - 1$$

$$6 = x - 1$$

$$7 = x$$

$$x = 7$$

99. Answers will vary.

100. $2x^2 - 5x + 1 = 0$
 $x^2 - \frac{5}{2}x + \frac{1}{2} = 0$

$$x^2 - \frac{5}{2}x = -\frac{1}{2}$$

$$x^2 - \frac{5}{2}x + \frac{25}{16} = -\frac{1}{2} + \frac{25}{16}$$

$$\left(x - \frac{5}{4}\right)^2 = \frac{17}{16}$$

$$x - \frac{5}{4} = \pm \sqrt{\frac{17}{16}}$$

$$x - \frac{5}{4} = \pm \frac{\sqrt{17}}{4}$$

$$x = \frac{5 \pm \sqrt{17}}{4}$$

The solution set is $\left\{ \frac{5 \pm \sqrt{17}}{4} \right\}$.

101. $5x^{3/4} - 15 = 0$

$$5x^{3/4} = 15$$

$$x^{3/4} = 3$$

$$\left(x^{3/4}\right)^{4/3} = \left(3\right)^{4/3}$$

$$x = 3^{4/3}$$

The solution set is $\{3^{4/3}\}$.

102. $3 \leq x - 1 \leq 21$

$$\begin{cases} 2x - 1 \geq 7 \\ 2x - 1 \leq -7 \end{cases} \quad 2x - 1 \geq 7$$

$$2x \leq -6 \quad \text{or} \quad 2x \geq 8$$

$$\frac{2x}{2} \leq \frac{-6}{2} \quad \frac{2x}{2} \geq \frac{8}{2}$$

$$x \leq -3 \quad x \geq 4$$

The solution set is $\{x | x \leq -3 \text{ or } x \geq 4\}$

or $(-\infty, -3] \cup [4, \infty)$.

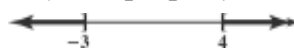

103. $\sqrt{(x_2 - x_1)^2 + (y_2 - y_1)^2} = \sqrt{(1 - 7)^2 + (-1 - 2)^2}$
 $= \sqrt{(-6)^2 + (-3)^2}$

$$= \sqrt{36 + 9}$$

$$= \sqrt{45}$$

$$= 3\sqrt{5}$$

104.

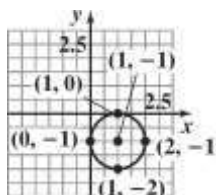

105. $y^2 - 6y - 4 = 0$

$$y^2 - 6y = 4$$

$$y^2 - 6y + 9 = 4 + 9$$

$$(y - 3)^2 = 13$$

$$y - 3 = \pm\sqrt{13}$$

$$y = 3 \pm \sqrt{13}$$

Solutionset: $\{3 \pm \sqrt{13}\}$

Section 2.8

Check Point Exercises

$$1. \quad d = \sqrt{(x_2 - x_1)^2 + (y_2 - y_1)^2}$$

$$d = \sqrt{(2 - (-1))^2 + (3 - (-3))^2}$$

$$= \sqrt{3^2 + 6^2}$$

$$= \sqrt{9 + 36}$$

$$= \sqrt{45}$$

$$= 3\sqrt{5}$$

$$\approx 6.71$$

$$2. \quad \left(\frac{1+7}{2}, \frac{2+6}{2} \right) = (4, 4)$$

$$\left(\frac{2}{2}, \frac{2}{2} \right) = (1, 1)$$

$$3. \quad h = 0, k = 0, r = 4;$$

$$(x - 0)^2 + (y - 0)^2 = 4^2$$

$$x^2 + y^2 = 16$$

$$4. \quad h = 0, k = -6, r = 10;$$

$$(x - 0)^2 + [y - (-6)]^2 = 10^2$$

$$(x - 0)^2 + (y + 6)^2 = 100$$

$$x^2 + (y + 6)^2 = 100$$

$$5. \quad a. \quad (x + 3)^2 + (y - 1)^2 = 4$$

$$[x - (-3)]^2 + (y - 1)^2 = 2^2$$

So in the standard form of the circle's equation $(x - h)^2 + (y - k)^2 = r^2$, we have $h = -3, k = 1, r = 2$.

center: $(h, k) = (-3, 1)$

radius: $r = 2$

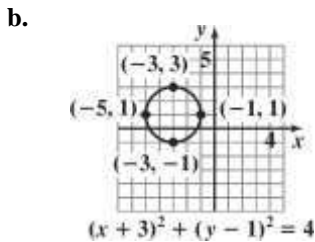

c. domain: $[-5, -1]$

range: $[-1, 3]$

$$6. \quad x^2 + y^2 + 4x - 4y - 1 = 0$$

$$x^2 + y^2 + 4x - 4y - 1 = 0$$

$$(x^2 + 4x) + (y^2 - 4y) = 1$$

$$(x^2 + 4x + 4) + (y^2 - 4y + 4) = 1 + 4 + 4$$

$$(x + 2)^2 + (y - 2)^2 = 9$$

$$[x - (-2)]^2 + (y - 2)^2 = 3^2$$

So in the standard form of the circle's equation $(x - h)^2 + (y - k)^2 = r^2$, we have $h = -2, k = 2, r = 3$.

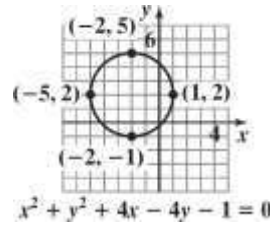

Concept and Vocabulary Check 2.8

$$1. \quad \sqrt{(x_2 - x_1)^2 + (y_2 - y_1)^2}$$

$$2. \quad \frac{x_1 + x_2}{2}; \quad \frac{y_1 + y_2}{2}$$

3. circle; center; radius

$$4. \quad (x - h)^2 + (y - k)^2 = r^2$$

5. general

6. 4; 16

Exercise Set 2.8

$$1. \quad d = \sqrt{(14 - 2)^2 + (8 - 3)^2}$$

$$= \sqrt{12^2 + 5^2}$$

$$= \sqrt{144 + 25}$$

$$= \sqrt{169}$$

$$= 13$$

$$\begin{aligned}
 2. \quad d &= \sqrt{(8-5)^2 + (5-1)^2} \\
 &= \sqrt{3^2 + 4^2} \\
 &= \sqrt{9+16} \\
 &= \sqrt{25} \\
 &= 5
 \end{aligned}$$

$$\begin{aligned}
 3. \quad d &= \sqrt{(-6-4)^2 + (3-(-1))^2} \\
 &= \sqrt{(-10)^2 + (4)^2} \\
 &= \sqrt{100+16} \\
 &= \sqrt{116} \\
 &= 2\sqrt{29} \\
 &\approx 10.77
 \end{aligned}$$

$$\begin{aligned}
 4. \quad d &= \sqrt{(-1-2)^2 + (5-(-3))^2} \\
 &= \sqrt{(-3)^2 + (8)^2} \\
 &= \sqrt{9+64} \\
 &= \sqrt{73} \\
 &\approx 8.54
 \end{aligned}$$

$$\begin{aligned}
 5. \quad d &= \sqrt{(-3-0)^2 + (4-0)^2} \\
 &= \sqrt{3^2 + 4^2} \\
 &= \sqrt{9+16} \\
 &= \sqrt{25} \\
 &= 5
 \end{aligned}$$

$$\begin{aligned}
 6. \quad d &= \sqrt{(3-0)^2 + (-4-0)^2} \\
 &= \sqrt{3^2 + (-4)^2} \\
 &= \sqrt{9+16} \\
 &= \sqrt{25} \\
 &= 5
 \end{aligned}$$

$$\begin{aligned}
 7. \quad d &= \sqrt{[3-(-2)]^2 + [-4-(-6)]^2} \\
 &= \sqrt{5^2 + 2^2} \\
 &= \sqrt{25+4} \\
 &= \sqrt{29} \\
 &\approx 5.39
 \end{aligned}$$

$$\begin{aligned}
 8. \quad d &= \sqrt{[2-(-4)]^2 + [-3-(-1)]^2} \\
 &= \sqrt{6^2 + (-2)^2} \\
 &= \sqrt{36+4} \\
 &= \sqrt{40} \\
 &= 2\sqrt{10} \\
 &\approx 6.32
 \end{aligned}$$

$$\begin{aligned}
 9. \quad d &= \sqrt{(4-0)^2 + [1-(-3)]^2} \\
 &= \sqrt{4^2 + 4^2} \\
 &= \sqrt{16+16} \\
 &= \sqrt{32} \\
 &= 4\sqrt{2} \\
 &\approx 5.66
 \end{aligned}$$

$$\begin{aligned}
 10. \quad d &= \sqrt{(4-0)^2 + [3-(-2)]^2} \\
 &= \sqrt{4^2 + [3+2]^2} \\
 &= \sqrt{16+5^2} \\
 &= \sqrt{16+25} \\
 &= \sqrt{41} \\
 &\approx 6.40
 \end{aligned}$$

$$\begin{aligned}
 11. \quad d &= \sqrt{(-.5-3.5)^2 + (6.2-8.2)^2} \\
 &= \sqrt{(-4)^2 + (-2)^2} \\
 &= \sqrt{16+4} \\
 &= \sqrt{20} \\
 &= \sqrt{4 \cdot 5} \\
 &= 2\sqrt{5} \\
 &\approx 4.47
 \end{aligned}$$

$$\begin{aligned}
 12. \quad d &= \sqrt{(1.6-2.6)^2 + (-5.7-1.3)^2} \\
 &= \sqrt{(-1)^2 + (-7)^2} \\
 &= \sqrt{1+49} \\
 &= \sqrt{50} \\
 &= 5\sqrt{2} \\
 &\approx 7.07
 \end{aligned}$$

$$\begin{aligned}
 13. \quad d &= \sqrt{(\sqrt{5}-0)^2 + [0 - (-3)]^2} \\
 &= \sqrt{(\sqrt{5})^2 + (3)^2} \\
 &= \sqrt{5+9} \\
 &= \sqrt{14} \\
 &= 2\sqrt{2} \\
 &\approx 2.83
 \end{aligned}$$

$$\begin{aligned}
 14. \quad d &= \sqrt{(\sqrt{7}-0)^2 + [0 - (-\sqrt{2})]^2} \\
 &= \sqrt{(\sqrt{7})^2 + [-\sqrt{2}]^2} \\
 &= \sqrt{7+2} \\
 &= \sqrt{9} \\
 &= 3
 \end{aligned}$$

$$\begin{aligned}
 15. \quad d &= \sqrt{(-\sqrt{3}-3)^2 + (4-5\sqrt{5})^2} \\
 &= \sqrt{(-4-\sqrt{3})^2 + (3-5\sqrt{5})^2} \\
 &= \sqrt{16(3)+9(5)} \\
 &= \sqrt{48+45} \\
 &= \sqrt{93} \\
 &\approx 9.64
 \end{aligned}$$

$$\begin{aligned}
 16. \quad d &= \sqrt{(-\sqrt{3}-2\sqrt{3})^2 + (5\sqrt{6}-\sqrt{6})^2} \\
 &= \sqrt{(-3\sqrt{3})^2 + (4\sqrt{6})^2} \\
 &= \sqrt{9 \cdot 3 + 16 \cdot 6} \\
 &= \sqrt{27+96} \\
 &= \sqrt{123} \\
 &\approx 11.09
 \end{aligned}$$

$$\begin{aligned}
 17. \quad d &= \sqrt{\left(\frac{1}{3}-\frac{7}{3}\right)^2 + \left(\frac{6}{5}-\frac{1}{5}\right)^2} \\
 &= \sqrt{(-2)^2 + 1^2} \\
 &= \sqrt{4+1} \\
 &= \sqrt{5} \\
 &\approx 2.24
 \end{aligned}$$

$$\begin{aligned}
 18. \quad d &= \sqrt{\left[\frac{3}{4}-\left(-\frac{1}{4}\right)\right]^2 + \left[\frac{6}{7}-\left(-\frac{1}{7}\right)\right]^2} \\
 &= \sqrt{\left(\frac{3}{4}+\frac{1}{4}\right)^2 + \left[\frac{6}{7}+\frac{1}{7}\right]^2} \\
 &= \sqrt{1^2 + 1^2} \\
 &= \sqrt{2} \\
 &\approx 1.41
 \end{aligned}$$

$$19. \quad \left(\frac{6+2}{2}, \frac{8+4}{2}\right) = (4, 6)$$

$$20. \quad \left(\frac{10+2}{2}, \frac{4+6}{2}\right) = (6, 5)$$

$$21. \quad \left(\frac{-2+(-6)}{2}, \frac{-8+(-2)}{2}\right) = (-4, -5)$$

$$22. \quad \left(\frac{-4+(-1)}{2}, \frac{-7+(-3)}{2}\right) = \left(-\frac{5}{2}, -5\right)$$

$$23. \quad \left(\frac{-3+6}{2}, \frac{-4+(-8)}{2}\right) = \left(\frac{3}{2}, -6\right)$$

$$24. \quad \left(\frac{-2+(-8)}{2}, \frac{-1+6}{2}\right) = \left(-5, \frac{5}{2}\right)$$

$$25. \quad \left(\frac{-7(5)+3(11)}{2}, \frac{6-4}{2}\right) = (-3, -2)$$

$$26. \left(\frac{2}{-1} + \frac{2}{-5} \right) \sqrt{15} = \left(\frac{4}{-15} \right) \sqrt{15}$$

$$= \left(-\frac{4}{15} \right) \sqrt{15} = \left(-\frac{4\sqrt{15}}{15} \right)$$

$$27. \left(\frac{8+(-6)}{2}, \frac{3\sqrt{5}-7}{2} \right) \sqrt{5}$$

$$= \left(\frac{2}{2}, \frac{3\sqrt{5}-7}{2} \right) \sqrt{5} = \left(1, \frac{3\sqrt{5}-7}{2} \right) \sqrt{5}$$

$$28. \left(\frac{7+3}{\sqrt{3}}, \frac{-6+(-2)}{\sqrt{3}} \right) = \left(\frac{10}{\sqrt{3}}, -\frac{8}{\sqrt{3}} \right)$$

$$= (5\sqrt{3}, -4)$$

$$29. \left(\frac{\sqrt{18} + \sqrt{24+4}}{2}, 0 \right) = \left(\frac{3\sqrt{2} + \sqrt{28}}{2}, 0 \right)$$

$$= \left(\frac{3\sqrt{2} + 2\sqrt{7}}{2}, 0 \right)$$

$$30. \left(\frac{\sqrt{50} + \sqrt{26+6}}{2}, \frac{2+0}{2} \right) = \left(\frac{5\sqrt{2} + \sqrt{32}}{2}, 1 \right)$$

$$= \left(\frac{5\sqrt{2} + 2\sqrt{2}}{2}, 1 \right) = (3\sqrt{2}, 1)$$

$$31. (x-0)^2 + (y-0)^2 = 7^2$$

$$x^2 + y^2 = 49$$

$$32. (x-0)^2 + (y-0)^2 = 8^2$$

$$x^2 + y^2 = 64$$

$$33. (x-3)^2 + (y-2)^2 = 5^2$$

$$(x-3)^2 + (y-2)^2 = 25$$

$$36. [x-(-3)]^2 + (y-5)^2 = 3^2$$

$$(x+3)^2 + (y-5)^2 = 9$$

$$37. [x-(-3)]^2 + [y-(-1)]^2 = (\sqrt{3})^2$$

$$(x+3)^2 + (y+1)^2 = 3$$

$$38. [x-(-5)]^2 + [y-(-3)]^2 = (\sqrt{5})^2$$

$$(x+5)^2 + (y+3)^2 = 5$$

$$39. [x-(-4)]^2 + (y-0)^2 = 10^2$$

$$(x+4)^2 + (y-0)^2 = 100$$

$$40. [x-(-2)]^2 + (y-0)^2 = 6^2$$

$$(x+2)^2 + y^2 = 36$$

$$41. x^2 + y^2 = 16$$

$$(x-0)^2 + (y-0)^2 = 4^2$$

$$h=0, k=0, r=4;$$

$$\text{center} = (0, 0); \text{radius} = 4$$

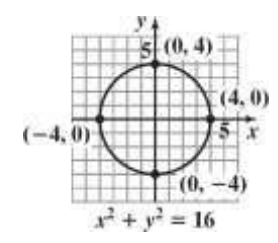

$$\text{domain: } [-4, 4]$$

$$\text{range: } [-4, 4]$$

$$42. x + y = 49$$

$$(x-0)^2 + (y-0)^2 = 7^2$$

$$34. (x-2)^2 + [y-(-1)]^2 = 4^2$$

$$(x-2)^2 + (y+1)^2 = 16$$

35. $[x - (-1)]^2 + (y - 4)^2 = 2^2$
 $(x + 1)^2 + (y - 4)^2 = 4$

$h = 0, k = 0, r = 7$;
 center = $(0, 0)$; radius = 7

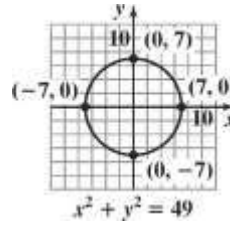

domain: $[-7, 7]$

range: $[-7, 7]$

43. $(x-3)^2 + (y-1)^2 = 36$
 $(x-3)^2 + (y-1)^2 = 6^2$
 $h = 3, k = 1, r = 6$;
 center = (3, 1); radius = 6

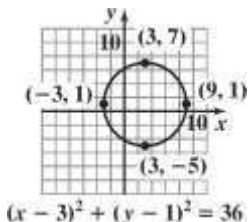

domain: $[-3, 9]$
 range: $[-5, 7]$

44. $(x-2)^2 + (y-3)^2 = 16$
 $(x-2)^2 + (y-3)^2 = 4^2$
 $h = 2, k = 3, r = 4$;
 center = (2, 3); radius = 4

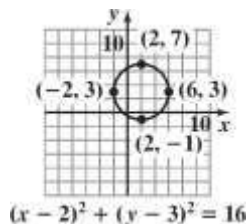

domain: $[-2, 6]$
 range: $[-1, 7]$

45. $(x+3)^2 + (y-2)^2 = 4$
 $[x - (-3)]^2 + (y - 2)^2 = 2^2$
 $h = -3, k = 2, r = 2$;
 center = (-3, 2); radius = 2

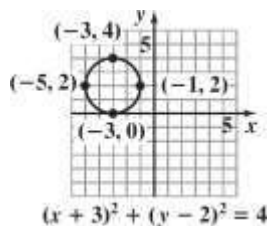

domain: $[-5, -1]$
 range: $[0, 4]$

46. $(x+1)^2 + (y-4)^2 = 25$
 $[x - (-1)]^2 + (y - 4)^2 = 5^2$
 $h = -1, k = 4, r = 5$;
 center = (-1, 4); radius = 5

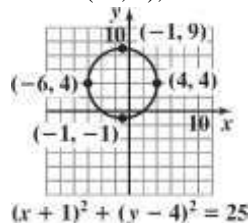

domain: $[-6, 4]$
 range: $[-1, 9]$

47. $(x+2)^2 + (y+2)^2 = 4$
 $[x - (-2)]^2 + [y - (-2)]^2 = 2^2$
 $h = -2, k = -2, r = 2$;
 center = (-2, -2); radius = 2

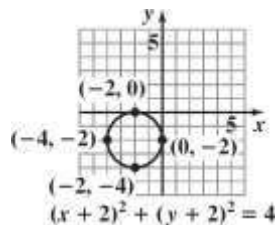

domain: $[-4, 0]$
 range: $[-4, 0]$

48. $(x+4)^2 + (y+5)^2 = 36$
 $[x - (-4)]^2 + [y - (-5)]^2 = 6^2$
 $h = -4, k = -5, r = 6$;
 center = (-4, -5); radius = 6

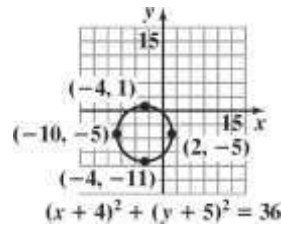

domain: $[-10, 2]$
 range: $[-11, 1]$

49. $x^2 + (y-1)^2 = 1$
 $h = 0, k = 1, r = 1$;
 center = $(0, 1)$; radius = 1

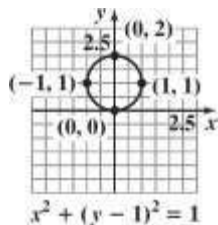

domain: $[-1, 1]$
 range: $[0, 2]$

50. $x^2 + (y-2)^2 = 4$
 $h = 0, k = 2, r = 2$;
 center = $(0, 2)$; radius = 2

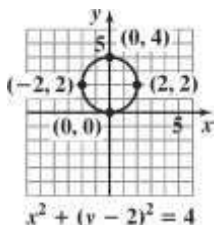

domain: $[-2, 2]$
 range: $[0, 4]$

51. $(x+1)^2 + y^2 = 25$
 $h = -1, k = 0, r = 5$;
 center = $(-1, 0)$; radius = 5

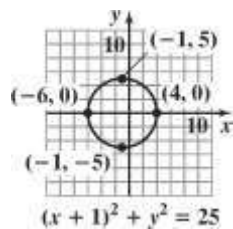

domain: $[-6, 4]$
 range: $[-5, 5]$

52. $(x+2)^2 + y^2 = 16$
 $h = -2, k = 0, r = 4$;
 center = $(-2, 0)$; radius = 4

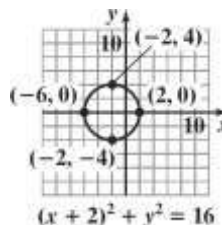

domain: $[-6, 2]$
 range: $[-4, 4]$

53. $x^2 + y^2 + 6x + 2y + 6 = 0$
 $(x^2 + 6x) + (y^2 + 2y) = -6$
 $(x^2 + 6x + 9) + (y^2 + 2y + 1) = 9 + 1 - 6$
 $(x+3)^2 + (y+1)^2 = 4$
 $[x - (-3)]^2 + [y - (-1)]^2 = 2^2$
 center = $(-3, -1)$; radius = 2

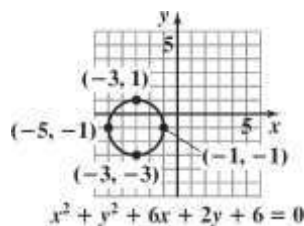

54. $x^2 + y^2 + 8x + 4y + 16 = 0$
 $(x^2 + 8x) + (y^2 + 4y) = -16$
 $(x^2 + 8x + 16) + (y^2 + 4y + 4) = 20 - 16$
 $(x+4)^2 + (y+2)^2 = 4$
 $[x - (-4)]^2 + [y - (-2)]^2 = 2^2$
 center = $(-4, -2)$; radius = 2

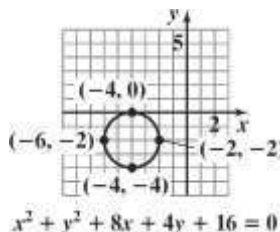

55. $x^2 + y^2 - 10x - 6y - 30 = 0$
 $(x^2 - 10x) + (y^2 - 6y) = 30$
 $(x^2 - 10x + 25) + (y^2 - 6y + 9) = 25 + 9 + 30$
 $(x - 5)^2 + (y - 3)^2 = 64$

$(x - 5)^2 + (y - 3)^2 = 8^2$
 center = (5, 3); radius = 8

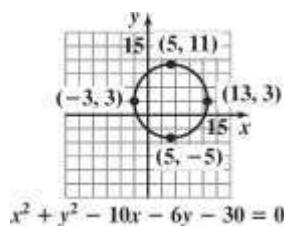

56. $x^2 + y^2 - 4x - 12y - 9 = 0$
 $(x^2 - 4x) + (y^2 - 12y) = 9$
 $(x^2 - 4x + 4) + (y^2 - 12y + 36) = 4 + 36 + 9$
 $(x - 2)^2 + (y - 6)^2 = 49$
 $(x - 2)^2 + (y - 6)^2 = 7^2$
 center = (2, 6); radius = 7

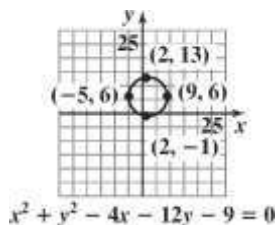

57. $x^2 + y^2 + 8x - 2y - 8 = 0$
 $(x^2 + 8x) + (y^2 - 2y) = 8$
 $(x^2 + 8x + 16) + (y^2 - 2y + 1) = 16 + 1 + 8$
 $(x + 4)^2 + (y - 1)^2 = 25$
 $[x - (-4)]^2 + (y - 1)^2 = 5^2$
 center = (-4, 1); radius = 5

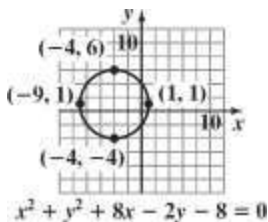

58. $x^2 + y^2 + 12x - 6y - 4 = 0$
 $(x^2 + 12x) + (y^2 - 6y) = 4$
 $(x^2 + 12x + 36) + (y^2 - 6y + 9) = 36 + 9 + 4$
 $[x - (-6)]^2 + (y - 3)^2 = 7^2$

center = (-6, 3); radius = 7

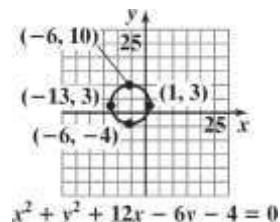

59. $x^2 - 2x + y^2 - 15 = 0$
 $(x^2 - 2x) + y^2 = 15$
 $(x^2 - 2x + 1) + (y - 0)^2 = 1 + 0 + 15$
 $(x - 1)^2 + (y - 0)^2 = 16$
 $(x - 1)^2 + (y - 0)^2 = 4^2$
 center = (1, 0); radius = 4

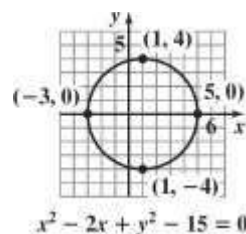

60. $x^2 + y^2 - 6y - 7 = 0$
 $x^2 + (y^2 - 6y) = 7$
 $(x - 0)^2 = (y^2 - 6y + 9) = 0 + 9 + 7$
 $(x - 0)^2 + (y - 3)^2 = 16$
 $(x - 0)^2 + (y - 3)^2 = 4^2$
 center = (0, 3); radius = 4

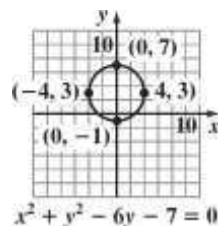

61. $x^2 + y^2 - x + 2y + 1 = 0$
 $x^2 - x + y^2 + 2y = -1$

$$x^2 - x + \frac{1}{4} + y^2 + 2y + 1 = -1 + \frac{1}{4} + 1$$

$$\left(x - \frac{1}{2}\right)^2 + (y + 1)^2 = 4$$

center = $\left(\frac{1}{2}, -1\right)$; radius = $\frac{1}{2}$

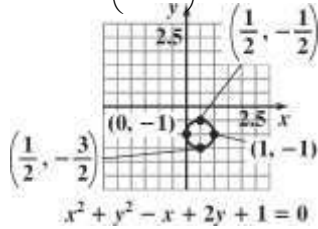

62. $x^2 + y^2 + x + y - \frac{1}{4} = 0$

$$x^2 + x + \frac{1}{4} + y^2 + y + \frac{1}{4} = \frac{1}{4} + \frac{1}{4} - \frac{1}{4}$$

$$\left(x + \frac{1}{2}\right)^2 + \left(y + \frac{1}{2}\right)^2 = \frac{1}{4}$$

center = $\left(-\frac{1}{2}, -\frac{1}{2}\right)$; radius = $\frac{1}{2}$

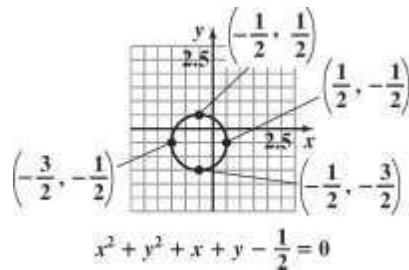

63. $x^2 + y^2 + 3x - 2y - 1 = 0$
 $x^2 + 3x + y^2 - 2y = 1$
 $x^2 + 3x + \frac{9}{4} + y^2 - 2y + 1 = 1 + \frac{9}{4} + 1$

$$\left(x + \frac{3}{2}\right)^2 + (y - 1)^2 = \frac{17}{4}$$

center = $\left(-\frac{3}{2}, 1\right)$; radius = $\frac{\sqrt{17}}{2}$

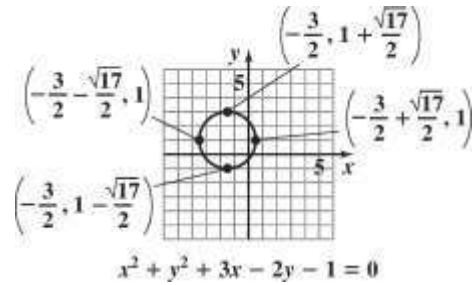

64. $x^2 + y^2 + 3x + 5y + \frac{9}{4} = 0$
 $x^2 + 3x + y^2 + 5y = -\frac{9}{4}$
 $x^2 + 3x + \frac{9}{4} + y^2 + 5y + \frac{25}{4} = -\frac{9}{4} + \frac{9}{4} + \frac{25}{4}$

$$\left(x + \frac{3}{2}\right)^2 + \left(y + \frac{5}{2}\right)^2 = \frac{25}{4}$$

center = $\left(-\frac{3}{2}, -\frac{5}{2}\right)$; radius = $\frac{5}{2}$

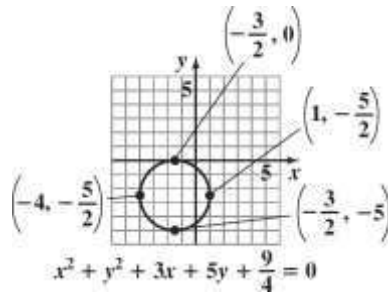

65. a. Since the line segment passes through the center, the center is the midpoint of the segment.

$$M = \left(\frac{x_1 + x_2}{2}, \frac{y_1 + y_2}{2}\right)$$

$$= \left(\frac{3 + 7 + 11}{2}, \frac{10 + 20}{2}\right)$$

$$= (5, 10)$$

The center is (5, 10).

- b. The radius is the distance from the center to one of the points on the circle. Using the point $(3, 9)$, we get:

$$\begin{aligned} d &= \sqrt{(5-3)^2 + (10-9)^2} \\ &= \sqrt{2^2 + 1^2} = \sqrt{4+1} \\ &= \sqrt{5} \end{aligned}$$

The radius is $\sqrt{5}$ units.

c. $(x-5)^2 + (y-10)^2 = (\sqrt{5})^2$
 $(x-5)^2 + (y-10)^2 = 5$

66. a. Since the line segment passes through the center, the center is the midpoint of the segment.

$$\begin{aligned} M &= \left(\frac{x_1 + x_2}{2}, \frac{y_1 + y_2}{2} \right) \\ &= \left(\frac{3 + 5}{2}, \frac{6 + 4}{2} \right) = \left(\frac{8}{2}, \frac{10}{2} \right) \\ &= (4, 5) \end{aligned}$$

The center is $(4, 5)$.

- b. The radius is the distance from the center to one of the points on the circle. Using the point $(3, 6)$, we get:

$$\begin{aligned} d &= \sqrt{(4-3)^2 + (5-6)^2} \\ &= \sqrt{1^2 + (-1)^2} = \sqrt{1+1} \\ &= \sqrt{2} \end{aligned}$$

The radius is $\sqrt{2}$ units.

c. $(x-4)^2 + (y-5)^2 = (\sqrt{2})^2$
 $(x-4)^2 + (y-5)^2 = 2$

67. $x^2 + y^2 = 16$
 $x - y = 4$

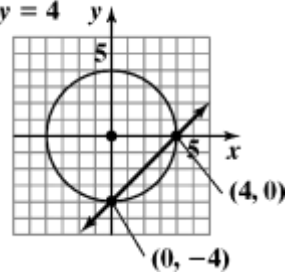

Intersection points: $(0, -4)$ and $(4, 0)$

Check $(0, -4)$:

$$\begin{aligned} 0^2 + (-4)^2 &= 16 & 0 - (-4) &= 4 \\ 16 &= 16 \text{ true} & 4 &= 4 \text{ true} \end{aligned}$$

Check $(4, 0)$:

$$\begin{aligned} 4^2 + 0^2 &= 16 & 4 - 0 &= 4 \\ 16 &= 16 \text{ true} & 4 &= 4 \text{ true} \end{aligned}$$

The solution set is $\{(0, -4), (4, 0)\}$.

68. $x^2 + y^2 = 9$
 $x - y = 3$

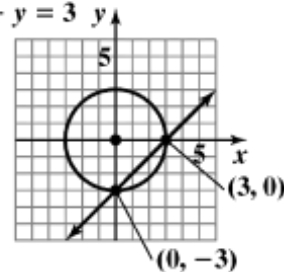

Intersection points: $(0, -3)$ and $(3, 0)$

Check $(0, -3)$:

$$\begin{aligned} 0^2 + (-3)^2 &= 9 & 0 - (-3) &= 3 \\ 9 &= 9 \text{ true} & 3 &= 3 \text{ true} \end{aligned}$$

Check $(3, 0)$:

$$\begin{aligned} 3^2 + 0^2 &= 9 & 3 - 0 &= 3 \\ 9 &= 9 \text{ true} & 3 &= 3 \text{ true} \end{aligned}$$

The solution set is $\{(0, -3), (3, 0)\}$.

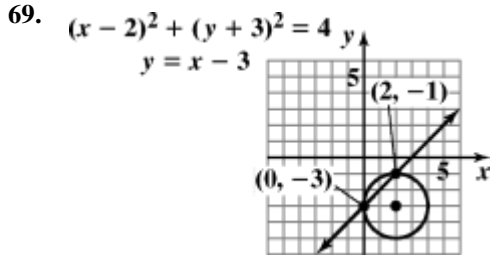

Intersection points: $(0, -3)$ and $(2, -1)$

Check $(0, -3)$:

$$\begin{aligned} (0-2)^2 + (-3+3)^2 &= 9 & -3 &= 0 - 3 \\ (-2)^2 + 0^2 &= 4 & -3 &= -3 \text{ true} \\ 4 &= 4 \\ &\text{true} \end{aligned}$$

Check $(2, -1)$:

$$\begin{aligned} (2-2)^2 + (-1+3)^2 &= 4 & -1 &= 2 - 3 \\ 0^2 + 2^2 &= 4 & -1 &= -1 \text{ true} \\ 4 &= 4 \\ &\text{true} \end{aligned}$$

The solution set is $\{(0, -3), (2, -1)\}$.

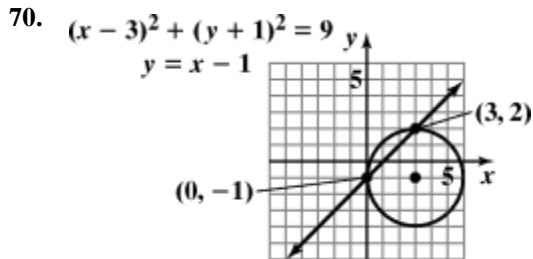

Intersection points: $(0, -1)$ and $(3, 2)$

Check $(0, -1)$:

$$\begin{aligned} (0-3)^2 + (-1+1)^2 &= 9 & -1 &= 0 - 1 \\ (-3)^2 + 0^2 &= 9 & -1 &= -1 \text{ true} \\ 9 &= 9 \\ &\text{true} \end{aligned}$$

Check $(3, 2)$:

$$\begin{aligned} (3-3)^2 + (2+1)^2 &= 9 \\ 0^2 + 3^2 &= 9 \\ 9 &= 9 \end{aligned}$$

71. $d = \sqrt{(8495 - 4422)^2 + (8720 - 1241)^2} \cdot \sqrt{0.1}$
 $d = \sqrt{2,524,770} \cdot \sqrt{0.1}$
 $d \approx 2693$

The distance between Boston and San Francisco is about 2693 miles.

72. $d = \sqrt{(8936 - 8448)^2 + (3542 - 2625)^2} \cdot \sqrt{0.1}$
 $d = \sqrt{1,079,033} \cdot \sqrt{0.1}$
 $d \approx 328$

The distance between New Orleans and Houston is about 328 miles.

73. If we place L.A. at the origin, then we want the equation of a circle with center at $(-2.4, -2.7)$ and radius 30.
 $(x - (-2.4))^2 + (y - (-2.7))^2 = 30^2$

$$(x + 2.4)^2 + (y + 2.7)^2 = 900$$

74. $C(0, 68 + 14) = (0, 82)$
 $(x - 0)^2 + (y - 82)^2 = 68^2$
 $x^2 + (y - 82)^2 = 4624$

75. – 82. Answers will vary.

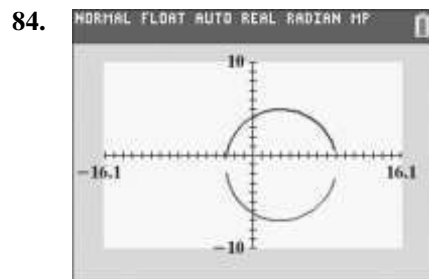
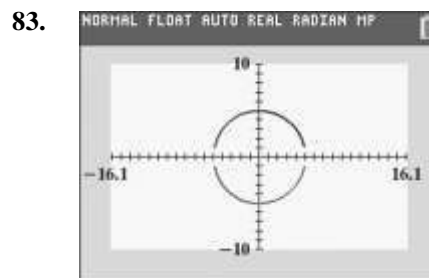

true

Chapter 2 Functions and Graphs

$$2 = 2 \text{ true}$$

$$2 = 3 - 1$$

The solution set is $\{(0, -1), (3, 2)\}$.

85.

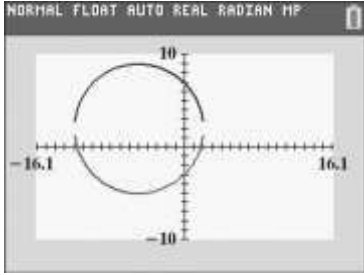

86. makes sense

87. makes sense

88. does not make sense; Explanations will vary.
Sample explanation: Since $r^2 = -4$ this is not the equation of a circle.

89. makes sense

90. false; Changes to make the statement true will vary.
A sample change is: The equation would be $x^2 + y^2 = 256$.

91. false; Changes to make the statement true will vary.
A sample change is: The center is at $(3, -5)$.

92. false; Changes to make the statement true will vary.
A sample change is: This is not an equation for a circle.

93. false; Changes to make the statement true will vary.
A sample change is: Since $r^2 = -36$ this is not the equation of a circle.

94. The distance for A to B:

$$\begin{aligned} \overline{AB} &= \sqrt{(3-1)^2 + [3+d-(1+d)]^2} \\ &= \sqrt{2^2 + 2^2} \\ &= \sqrt{4+4} \\ &= \sqrt{8} \\ &= 2\sqrt{2} \end{aligned}$$

The distance from B to C:

$$\begin{aligned} \overline{BC} &= \sqrt{(6-3)^2 + [3+d-(6+d)]^2} \\ &= \sqrt{3^2 + (-3)^2} \\ &= \sqrt{9+9} \\ &= \sqrt{18} \\ &= 3\sqrt{2} \end{aligned}$$

The distance for A to C:

$$\begin{aligned} \overline{AC} &= \sqrt{(6-1)^2 + [6+d-(1+d)]^2} \\ &= \sqrt{5^2 + 5^2} \\ &= \sqrt{25+25} \\ &= \sqrt{50} \\ &= 5\sqrt{2} \\ \overline{AB} + \overline{BC} &= \overline{AC} \\ 2\sqrt{2} + 3\sqrt{2} &= 5\sqrt{2} \\ 5\sqrt{2} &= 5\sqrt{2} \end{aligned}$$

95.

a. d_1 is distance from (x_1, x_2) to midpoint

$$\begin{aligned} d_1 &= \sqrt{\left(\frac{x_1+x_2}{2} - x_1\right)^2 + \left(\frac{y_1+y_2}{2} - y_1\right)^2} \\ d_1 &= \sqrt{\left(\frac{x_1+x_2-2x_1}{2}\right)^2 + \left(\frac{y_1+y_2-2y_1}{2}\right)^2} \\ d_1 &= \sqrt{\left(\frac{x_2-x_1}{2}\right)^2 + \left(\frac{y_2-y_1}{2}\right)^2} \\ d_1 &= \sqrt{\frac{x_2^2-2x_1x_2+x_1^2}{4} + \frac{y_2^2-2y_1y_2+y_1^2}{4}} \\ d_1 &= \sqrt{\frac{1}{4}(x_2^2-2x_1x_2+x_1^2+y_2^2-2y_1y_2+y_1^2)} \\ d_1 &= \frac{1}{2}\sqrt{x_2^2-2x_1x_2+x_1^2+y_2^2-2y_1y_2+y_1^2} \end{aligned}$$

d_2 is distance from midpoint to (x_2, y_2)

$$\begin{aligned} d_2 &= \sqrt{\left(\frac{x_1+x_2}{2} - x_2\right)^2 + \left(\frac{y_1+y_2}{2} - y_2\right)^2} \\ d_2 &= \sqrt{\left(\frac{x_1+x_2-2x_2}{2}\right)^2 + \left(\frac{y_1+y_2-2y_2}{2}\right)^2} \\ d_2 &= \sqrt{\left(\frac{x_1-x_2}{2}\right)^2 + \left(\frac{y_1-y_2}{2}\right)^2} \\ d_2 &= \sqrt{\frac{x_1^2-2x_1x_2+x_2^2}{4} + \frac{y_1^2-2y_1y_2+y_2^2}{4}} \\ d_2 &= \sqrt{\frac{1}{4}(x_1^2-2x_1x_2+x_2^2+y_1^2-2y_1y_2+y_2^2)} \\ d_2 &= \frac{1}{2}\sqrt{x_1^2-2x_1x_2+x_2^2+y_1^2-2y_1y_2+y_2^2} \\ d_1 &= d_2 \end{aligned}$$

b. d_3 is the distance from (x_1, y_1) to (x_2, y_2)

$$d_3 = \sqrt{(x_2 - x_1)^2 + (y_2 - y_1)^2}$$

$$d_3 = \sqrt{x_2^2 - 2x_1x_2 + x_1^2 + y_2^2 - 2y_1y_2 + y_1^2}$$

$$d + d = d \quad \text{because} \quad \frac{1}{-}\sqrt{a} + \frac{1}{-}\sqrt{a} = \sqrt{a}$$

1
2
3
2
2

96. Both circles have center $(2, -3)$. The smaller circle has radius 5 and the larger circle has radius 6. The smaller circle is inside of the larger circle. The area between them is given by

$$\pi(6)^2 - \pi(5)^2 = 36\pi - 25\pi$$

$$= 11\pi$$

$$\approx 34.56 \text{ square units.}$$

97. The circle is centered at $(0,0)$. The slope of the radius with endpoints $(0,0)$ and $(3,-4)$ is

$$m = -\frac{4-0}{3-0} = -\frac{4}{3}$$

The line perpendicular to the

radius has slope $\frac{3}{4}$. The tangent line has slope $\frac{3}{4}$ and

passes through $(3,-4)$, so its equation is:

$$y + 4 = \frac{3}{4}(x - 3)$$

98. $7(x - 2) + 5 = 7x - 9$

$$7x - 14 + 5 = 7x - 9$$

$$7x - 9 = 7x - 9$$

$$-9 = -9$$

The original equation is equivalent to the statement $-9 = -9$, which is true for every value of x .

The equation is an identity, and all real numbers are solutions. The solution set $\{x | x \text{ is a real number}\}$.

99. $\frac{4i+7}{5-2i} = \frac{4i+7}{5-2i} \cdot \frac{5+2i}{5+2i}$

$$= \frac{20i + 8i^2 + 35 + 14i}{25 + 10i - 10i - 4i^2}$$

$$= \frac{34i - 8 + 35}{25 + 4}$$

$$= \frac{34i + 27}{29}$$

$$= \frac{27}{29} + \frac{34}{29}i$$

100. $-9 \leq 4x - 1 < 15$

$$-8 \leq 4x < 16$$

$$-2 \leq x < 4$$

The solution set is $\{x | -2 \leq x < 4\}$ or $[-2, 4)$.



101. $0 = -2(x - 3)^2 + 8$

$$2(x - 3)^2 = 8$$

$$(x - 3)^2 = 4$$

$$x - 3 = \pm\sqrt{4}$$

$$x = 3 \pm 2$$

$$x = 1, 5$$

102. $-x^2 - 2x + 1 = 0$

$$x^2 + 2x - 1 = 0$$

$$x = \frac{-b \pm \sqrt{b^2 - 4ac}}{2a}$$

$$x = \frac{-(-2) \pm \sqrt{(-2)^2 - 4(1)(-1)}}{2(1)}$$

$$= \frac{2 \pm \sqrt{8}}{2}$$

$$= \frac{2 \pm 2\sqrt{2}}{2}$$

$$= 1 \pm \sqrt{2}$$

The solution set is $\{1 \pm \sqrt{2}\}$.

103. The graph of g is the graph of f shifted 1 unit up and 3 units to the left.

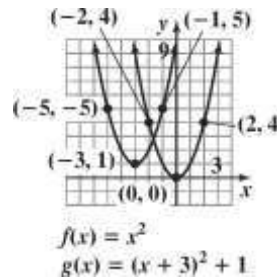

Chapter 2 Review Exercises

1. function

domain: $\{2, 3, 5\}$

range: $\{7\}$

2. function

domain: $\{1, 2, 13\}$

range: $\{10, 500, \pi\}$

3. not a function

domain: $\{12, 14\}$

range: $\{13, 15, 19\}$

4. $2x + y = 8$

$$y = -2x + 8$$

Since only one value of y can be obtained for each value of x , y is a function of x .

5. $3x^2 + y = 14$

$$y = -3x^2 + 14$$

Since only one value of y can be obtained for each value of x , y is a function of x .

6. $2x + y^2 = 6$

$$y^2 = -2x + 6$$

$$y = \pm \sqrt{-2x + 6}$$

Since more than one value of y can be obtained from some values of x , y is not a function of x .

7. $f(x) = 5 - 7x$

a. $f(4) = 5 - 7(4) = -23$

b. $f(x+3) = 5 - 7(x+3)$

$$= 5 - 7x - 21$$

$$= -7x - 16$$

c. $f(-x) = 5 - 7(-x) = 5 + 7x$

8. $g(x) = 3x^2 - 5x + 2$

a. $g(0) = 3(0)^2 - 5(0) + 2 = 2$

b. $g(-2) = 3(-2)^2 - 5(-2) + 2$

$$= 12 + 10 + 2$$

$$= 24$$

c. $g(x-1) = 3(x-1)^2 - 5(x-1) + 2$

$$= 3(x^2 - 2x + 1) - 5x + 5 + 2$$

$$= 3x^2 - 11x + 10$$

d. $g(-x) = 3(-x)^2 - 5(-x) + 2$

$$= 3x^2 + 5x + 2$$

9. a. $g(13) = \sqrt{13-4} = \sqrt{9} = 3$

b. $g(0) = 4 - 0 = 4$

c. $g(-3) = 4 - (-3) = 7$

10. a. $f(-2) = \frac{(-2)^2 - 1}{-2 - 1} = \frac{3}{-3} = -1$

b. $f(1) = 12$

c. $f(2) = \frac{2^2 - 1}{2 - 1} = \frac{3}{1} = 3$

11. The vertical line test shows that this is not the graph of a function.

12. The vertical line test shows that this is the graph of a function.

13. The vertical line test shows that this is the graph of a function.

14. The vertical line test shows that this is not the graph of a function.

15. The vertical line test shows that this is not the graph of a function.

16. The vertical line test shows that this is the graph of a function.

17. a. domain: $[-3, 5)$ b. range: $[-5, 0]$ c. x -intercept: -3 d. y -intercept: -2 e. increasing: $(-2, 0)$ or $(3, 5)$ decreasing: $(-3, -2)$ or $(0, 3)$ f. $f(-2) = -3$ and $f(3) = -5$

18. a. domain: $(-\infty, \infty)$

b. range: $(-\infty, 3]$

c. x -intercepts: -2 and 3

d. y -intercept: 3

e. increasing: $(-\infty, 0)$
decreasing: $(0, \infty)$

f. $f(-2) = 0$ and $f(6) = -3$

19. a. domain: $(-\infty, \infty)$

b. range: $[-2, 2]$

c. x -intercept: 0

d. y -intercept: 0

e. increasing: $(-2, 2)$
constant: $(-\infty, -2)$ or $(2, \infty)$

f. $f(-9) = -2$ and $f(14) = 2$

20. a. 0 , relative maximum -2

b. $-2, 3$, relative minimum $-3, -5$

21. a. 0 , relative maximum 3

b. none

22. Test for symmetry with respect to the y -axis.

$$y = x^2 + 8$$

$$y = (-x)^2 + 8$$

$$y = x^2 + 8$$

The resulting equation is equivalent to the original. Thus, the graph is symmetric with respect to the y -axis.

Test for symmetry with respect to the x -axis.

$$y = x^2 + 8$$

$$-y = x^2 + 8$$

$$y = -x^2 - 8$$

The resulting equation is not equivalent to the original. Thus, the graph is not symmetric with respect to the x -axis.

Test for symmetry with respect to the origin.

$$y = x^2 + 8$$

$$-y = (-x)^2 + 8$$

$$-y = x^2 + 8$$

$$y = -x^2 - 8$$

The resulting equation is not equivalent to the original. Thus, the graph is not symmetric with respect to the origin.

23. Test for symmetry with respect to the y -axis.

$$x^2 + y^2 = 17$$

$$(-x)^2 + y^2 = 17$$

$$x^2 + y^2 = 17$$

The resulting equation is equivalent to the original. Thus, the graph is symmetric with respect to the y -axis.

Test for symmetry with respect to the x -axis.

$$x^2 + y^2 = 17$$

$$x^2 + (-y)^2 = 17$$

$$x^2 + y^2 = 17$$

The resulting equation is equivalent to the original. Thus, the graph is symmetric with respect to the x -axis.

Test for symmetry with respect to the origin.

$$x^2 + y^2 = 17$$

$$(-x)^2 + (-y)^2 = 17$$

$$x^2 + y^2 = 17$$

The resulting equation is equivalent to the original. Thus, the graph is symmetric with respect to the origin.

24. Test for symmetry with respect to the y -axis.

$$x^3 - y^2 = 5$$

$$(-x)^3 - y^2 = 5$$

$$-x^3 - y^2 = 5$$

The resulting equation is not equivalent to the original. Thus, the graph is not symmetric with respect to the y -axis.

Test for symmetry with respect to the x -axis.

$$x^3 - y^2 = 5$$

$$x^3 - (-y)^2 = 5$$

$$x^3 - y^2 = 5$$

The resulting equation is equivalent to the original. Thus, the graph is symmetric with respect to the x -axis.

Test for symmetry with respect to the origin.

$$x^3 - y^2 = 5$$

$$(-x)^3 - (-y)^2 = 5$$

$$-x^3 - y^2 = 5$$

The resulting equation is not equivalent to the original. Thus, the graph is not symmetric with respect to the origin.

25. The graph is symmetric with respect to the origin. The function is odd.
26. The graph is not symmetric with respect to the y-axis or the origin. The function is neither even nor odd.
27. The graph is symmetric with respect to the y-axis. The function is even.
28. $f(x) = x^3 - 5x$
 $f(-x) = (-x)^3 - 5(-x)$
 $= -x^3 + 5x$
 $= -f(x)$
 The function is odd. The function is symmetric with respect to the origin.
29. $f(x) = x^4 - 2x^2 + 1$
 $f(-x) = (-x)^4 - 2(-x)^2 + 1$
 $= x^4 - 2x^2 + 1$
 $= f(x)$
 The function is even. The function is symmetric with respect to the y-axis.

30. $f(x) = 2x\sqrt{1-x^2}$
 $f(-x) = 2(-x)\sqrt{1-(-x)^2}$
 $= -2x\sqrt{1-x^2}$
 $= -f(x)$
 The function is odd. The function is symmetric with respect to the origin.

31. a.

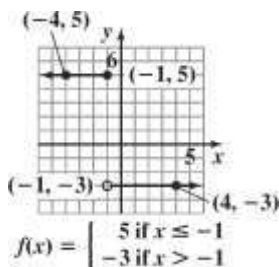

b. range: $\{-3, 5\}$

32. a.

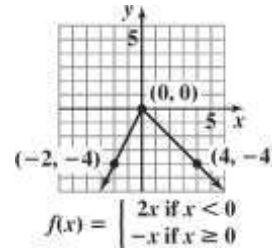

b. range: $\{y \mid y \leq 0\}$

33. $\frac{8(x+h) - 11 - (8x - 11)}{h}$
 $= \frac{8x + 8h - 11 - 8x + 11}{h}$
 $= \frac{8h}{h}$
 $= 8$

$$-2(x+h)^2 + (x+h) + 10 - (-2x^2 + x + 10)$$

34. $\frac{-2(x+h)^2 + (x+h) + 10 - (-2x^2 + x + 10)}{h}$
 $= \frac{-2(x^2 + 2xh + h^2) + x + h + 10 + 2x^2 - x - 10}{h}$
 $= \frac{-2x^2 - 4xh - 2h^2 + x + h + 10 + 2x^2 - x - 10}{h}$
 $= \frac{-4xh - 2h^2 + h}{h}$
 $= \frac{h(-4x - 2h + 1)}{h}$
 $= -4x - 2h + 1$

35. a. Yes, the eagle's height is a function of time since the graph passes the vertical line test.
- b. Decreasing: (3, 12)
 The eagle descended.
- c. Constant: (0, 3) or (12, 17)
 The eagle's height held steady during the first 3 seconds and the eagle was on the ground for 5 seconds.
- d. Increasing: (17, 30)
 The eagle was ascending.

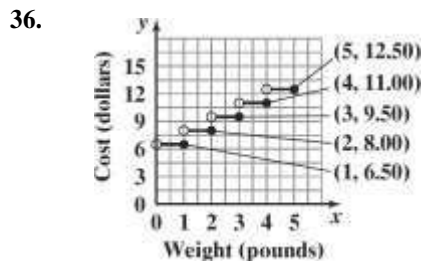

$$\frac{1-2}{-1} = \frac{-1}{-1} = 1$$

37. $m = \frac{5-3}{2} = \frac{2}{2} = 1$; falls

38. $m = \frac{-4-(-2)}{-3-(-1)} = \frac{-2}{-2} = 1$; rises

39. $m = \frac{\frac{1}{4}-\frac{1}{4}}{6-(-3)} = \frac{0}{9} = 0$; horizontal

40. $m = \frac{10-5}{-2-(-2)} = \frac{5}{0}$ undefined; vertical

41. point-slope form: $y - 2 = -6(x + 3)$
slope-intercept form: $y = -6x - 16$

42. $m = \frac{2-6}{-1-1} = \frac{-4}{-2} = 2$
point-slope form: $y - 6 = 2(x - 1)$
or $y - 2 = 2(x + 1)$
slope-intercept form: $y = 2x + 4$

43. $3x + y - 9 = 0$
 $y = -3x + 9$
 $m = -3$
point-slope form:
 $y + 7 = -3(x - 4)$
slope-intercept form:
 $y = -3x + 12 - 7$
 $y = -3x + 5$

44. perpendicular to $y = \frac{1}{3}x + 4$

$$m = -3$$

point-slope form:
 $y - 6 = -3(x + 3)$
slope-intercept form:
 $y = -3x - 9 + 6$
 $y = -3x - 3$

45. Write $6x - y - 4 = 0$ in slope intercept form.

$$6x - y - 4 = 0$$

$$-y = -6x + 4$$

$$y = 6x - 4$$

The slope of the perpendicular line is 6, thus the slope of the desired line is $m = -\frac{1}{6}$.

$$y - y_1 = m(x - x_1)$$

$$y - (-1) = -\frac{1}{6}(x - (-12))$$

$$y + 1 = -\frac{1}{6}(x + 12)$$

$$y + 1 = -\frac{1}{6}x - 2$$

$$6y + 6 = -x - 12$$

$$x + 6y + 18 = 0$$

46. slope: $\frac{2}{5}$; y-intercept: -1

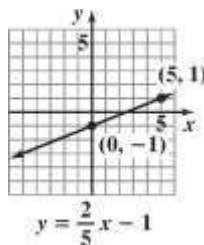

47. slope: -4 ; y-intercept: 5

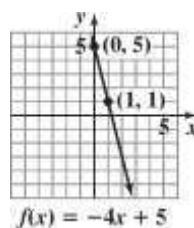

48. $2x + 3y + 6 = 0$
 $3y = -2x - 6$
 $y = -\frac{2}{3}x - 2$

slope: $-\frac{2}{3}$; y-intercept: -2

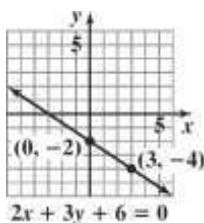

49. $2y - 8 = 0$

$2y = 8$

$y = 4$

slope: 0; y-intercept: 4

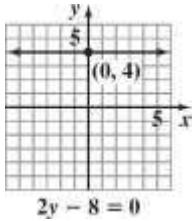

50. $2x - 5y - 10 = 0$

Find x-intercept:

$2x - 5(0) - 10 = 0$

$2x - 10 = 0$

$2x = 10$

$x = 5$

Find y-intercept:

$2(0) - 5y - 10 = 0$

$-5y - 10 = 0$

$-5y = 10$

$y = -2$

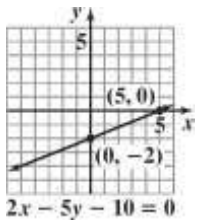

51. $2x - 10 = 0$

$2x = 10$

$x = 5$

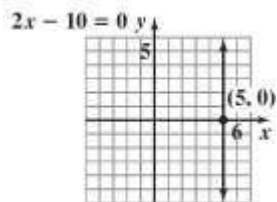

52. a. First, find the slope using the points (2, 28.2) and (4, 28.6).

$$m = \frac{28.6 - 28.2}{4 - 2} = \frac{0.4}{2} = 0.2$$

Then use the slope and one of the points to write

the equation in point-slope form.

$$y - y_1 = m(x - x_1)$$

$$y - 28.2 = 0.2(x - 2)$$

or

$$y - 28.6 = 0.2(x - 4)$$

b. Solve for y to obtain slope-intercept form.

$$y - 28.2 = 0.2(x - 2)$$

$$y - 28.2 = 0.2x - 0.4$$

$$y = 0.2x + 27.8$$

$$f(x) = 0.2x + 27.8$$

c. $f(x) = 0.2x + 27.8$

$$f(7) = 0.2(12) + 27.8$$

$$= 30.2$$

The linear function predicts men's average age of first marriage will be 30.2 years in 2020.

53. a. $m = \frac{27 - 21}{2010 - 1980} = \frac{6}{30} = 0.2$

b. For the period shown, the number of the percentage of liberal college freshman increased each year by approximately 0.2. The rate of change was 0.2% per year.

54. $\frac{f(x_2) - f(x_1)}{x_2 - x_1} = \frac{[9^2 - 4(9)] - [4^2 - 4 \cdot 5]}{9 - 5} = 10$

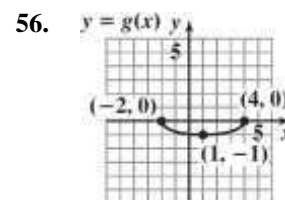
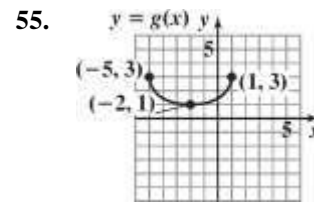

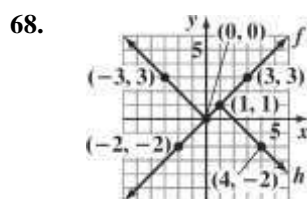
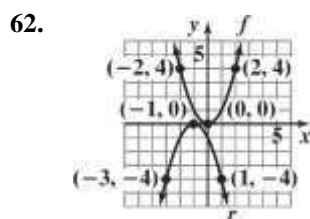
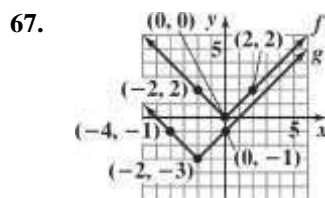
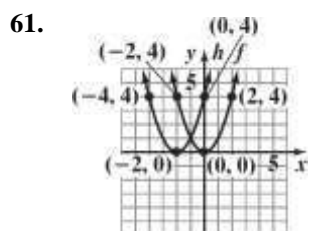
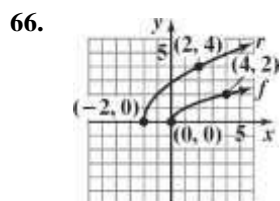
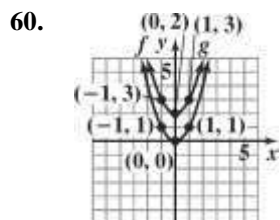
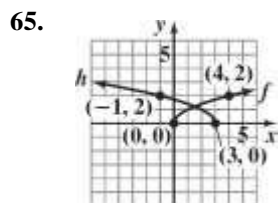
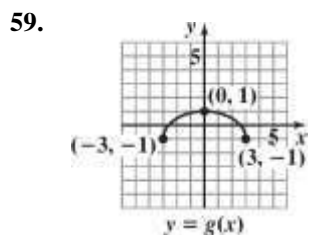
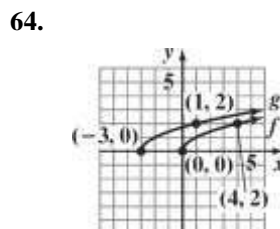
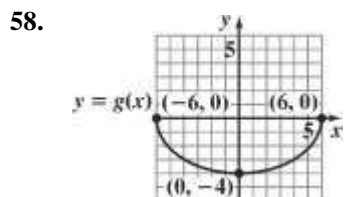
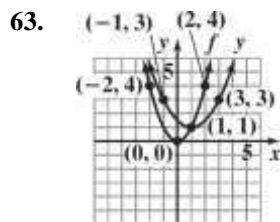
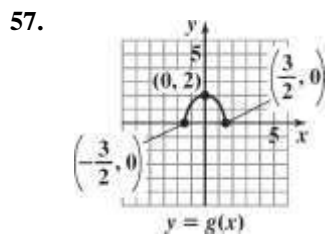

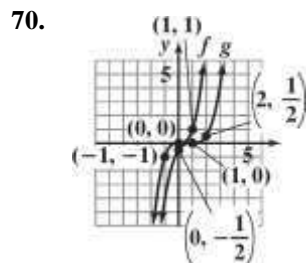
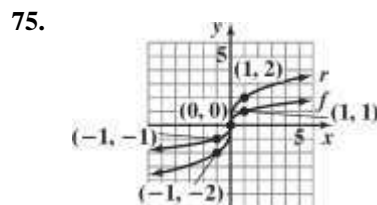
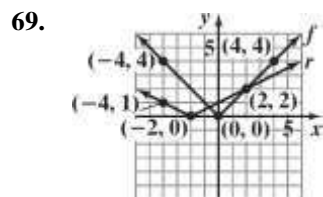

76. domain: $(-\infty, \infty)$

77. The denominator is zero when $x = 7$. The domain is $(-\infty, 7) \cup (7, \infty)$.

78. The expressions under each radical must not be negative.
 $8 - 2x \geq 0$
 $-2x \geq -8$
 $x \leq 4$
 domain: $(-\infty, 4]$.

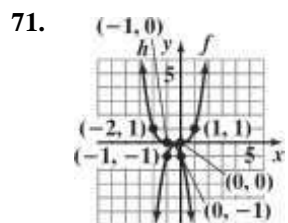

79. The denominator is zero when $x = -7$ or $x = 3$.
 domain: $(-\infty, -7) \cup (-7, 3) \cup (3, \infty)$

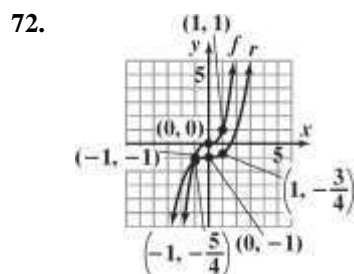

80. The expressions under each radical must not be negative. The denominator is zero when $x = 5$.
 $x - 2 \geq 0$
 $x \geq 2$
 domain: $[2, 5) \cup (5, \infty)$

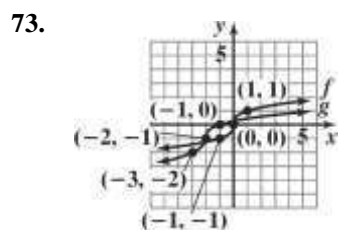

81. The expressions under each radical must not be negative.
 $x - 1 \geq 0$ and $x + 5 \geq 0$
 $x \geq 1$ and $x \geq -5$
 domain: $[1, \infty)$

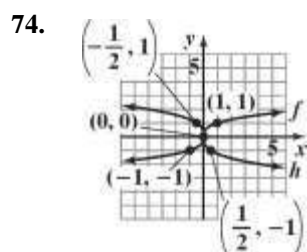

82. $f(x) = 3x - 1$; $g(x) = x - 5$
 $(f + g)(x) = 4x - 6$
 domain: $(-\infty, \infty)$
 $(f - g)(x) = (3x - 1) - (x - 5) = 2x + 4$
 domain: $(-\infty, \infty)$
 $(fg)(x) = (3x - 1)(x - 5) = 3x^2 - 16x + 5$
 domain: $(-\infty, \infty)$
 $\left(\frac{f}{g}\right)(x) = \frac{3x - 1}{x - 5}$
 domain: $(-\infty, 5) \cup (5, \infty)$

83. $f(x) = x^2 + x + 1$; $g(x) = x^2 - 1$
 $(f + g)(x) = 2x^2 + x$
 domain: $(-\infty, \infty)$
 $(f - g)(x) = (x^2 + x + 1) - (x^2 - 1) = x + 2$
 domain: $(-\infty, \infty)$
 $(fg)(x) = (x^2 + x + 1)(x^2 - 1)$
 $= x^4 + x^3 - x - 1$

$$\left(\frac{f}{g}\right)(x) = \frac{x^2 + x + 1}{x^2 - 1}$$

domain: $(-\infty, -1) \cup (-1, 1) \cup (1, \infty)$

84. $f(x) = \sqrt{x+7}$; $g(x) = \sqrt{x-2}$
 $(f + g)(x) = \sqrt{x+7} + \sqrt{x-2}$
 domain: $[2, \infty)$
 $(f - g)(x) = \sqrt{x+7} - \sqrt{x-2}$
 domain: $[2, \infty)$

$$(fg)(x) = \sqrt{x+7} \cdot \sqrt{x-2}$$

$$= \sqrt{x^2 + 5x - 14}$$

domain: $[2, \infty)$

$$\left(\frac{f}{g}\right)(x) = \frac{\sqrt{x+7}}{\sqrt{x-2}}$$

domain: $(2, \infty)$

85. $f(x) = x^2 + 3$; $g(x) = 4x - 1$

a. $(f \circ g)(x) = (4x - 1)^2 + 3$
 $= 16x^2 - 8x + 4$

b. $(g \circ f)(x) = 4(x^2 + 3) - 1$
 $= 4x^2 + 11$

c. $(f \circ g)(3) = 16(3)^2 - 8(3) + 4 = 124$

86. $f(x) = \sqrt{x}$; $g(x) = x + 1$

a. $(f \circ g)(x) = \sqrt{x+1}$

b. $(g \circ f)(x) = \sqrt{x} + 1$

c. $(f \circ g)(3) = \sqrt{3+1} = \sqrt{4} = 2$

87. a. $(f \circ g)(x) = f\left(\frac{1}{x}\right)$
 $= \frac{1}{1 + \frac{1}{x}} = \frac{x}{x+1}$
 $= \frac{1}{1 + \frac{1}{x}} = \frac{x}{x+1}$
 $= \frac{1}{1 + \frac{1}{x}} = \frac{x}{x+1}$
 $= \frac{1}{1 + \frac{1}{x}} = \frac{x}{x+1}$

b. $x \neq 0$ $1 - 2x \neq 0$
 1

$$(-\infty, 0) \cup \left(0, \frac{1}{2}\right) \cup \left(\frac{1}{2}, \infty\right)$$

88. a. $(f \circ g)(x) = f(x+3) = \sqrt{x+3-1} = \sqrt{x+2}$

b. $x + 2 \geq 0$ $[-2, \infty)$
 $x \geq -2$

89. $f(x) = x^4$ $g(x) = x^2 + 2x - 1$

90. $f(x) = 3x$ $g(x) = 7x + 4$

$$\sqrt{\quad}$$

91. $f(x) = \frac{3}{5}x + \frac{1}{2}$; $g(x) = \frac{5}{3}x - 2$

$$f(g(x)) = \frac{3}{5}\left(\frac{5}{3}x - 2\right) + \frac{1}{2}$$

$$= x - \frac{6}{5} + \frac{1}{2}$$

$$= x - \frac{10}{10} + \frac{5}{10}$$

$$= x - \frac{5}{10}$$

$$g(f(x)) = \frac{5}{3}\left(\frac{3}{5}x + \frac{1}{2}\right) - 2$$

$$= x + \frac{5}{6} - 2$$

$$= x - \frac{7}{6}$$

f and g are not inverses of each other.

92. $f(x) = 2 - 5x; g(x) = \frac{2-x}{5}$

$$f(g(x)) = 2 - 5\left(\frac{2-x}{5}\right)$$

$$= 2 - (2-x)$$

$$= x$$

$$g(f(x)) = \frac{2-(2-5x)}{5} = \frac{5x}{5} = x$$

f and g are inverses of each other.

93. a. $f(x) = 4x - 3$

$$y = 4x - 3$$

$$x = \frac{y+3}{4}$$

$$\frac{x+3}{4}$$

$$y = \frac{x+3}{4}$$

$$f^{-1}(x) = \frac{x+3}{4}$$

b. $f(f^{-1}(x)) = 4\left(\frac{x+3}{4}\right) - 3$

$$= x + 3 - 3$$

$$= x$$

$$f^{-1}(f(x)) = \frac{(4x-3)+3}{4} = \frac{4x}{4} = x$$

94. a. $f(x) = 8x^3 + 1$

$$y = 8x^3 + 1$$

$$x = \sqrt[3]{\frac{y-1}{8}}$$

$$x - 1 = \sqrt[3]{\frac{y-1}{8}} - 1$$

$$\frac{x-1}{2} = \sqrt[3]{\frac{y-1}{8}}$$

$$\sqrt[3]{\frac{x-1}{2}} = y$$

$$\frac{\sqrt[3]{x-1}}{2} = y$$

$$f^{-1}(x) = \frac{\sqrt[3]{x-1}}{2}$$

b. $f(f^{-1}(x)) = 8\left(\sqrt[3]{\frac{x-1}{8}}\right) + 1$

$$= 8\left(\frac{\sqrt[3]{x-1}}{2}\right) + 1$$

$$= 4\sqrt[3]{x-1} + 1$$

$$= x - 1 + 1$$

$$= x$$

$$f^{-1}(f(x)) = \frac{\sqrt[3]{8x^3+1}-1}{2}$$

$$= \frac{\sqrt[3]{8x^3}}{2}$$

$$= \frac{2x}{2}$$

$$= x$$

95. a.

$$f(x) = \frac{x-7}{x+2}$$

$$y = \frac{x-7}{x+2}$$

$$\frac{y-7}{y-2}$$

$$x = \frac{y-7}{y-2}$$

$$xy + 2x = y - 7$$

$$xy - y = -2x - 7$$

$$y(x-1) = -2x - 7$$

$$y = \frac{-2x-7}{x-1}$$

$$f^{-1}(x) = \frac{-2x-7}{x-1}, x \neq 1$$

$$\begin{aligned}
 & \frac{-2x-7}{x-1} - 7 \\
 \text{b. } f(f^{-1}(x)) &= \frac{\frac{x-1}{-2x-7} + 2}{\frac{x-1}{-2x-7} - 7} \\
 &= \frac{-2x-7+2(x-1)}{-2x-7-7(x-1)} \\
 &= \frac{-2x-7+2x-2}{-2x-7-7x+7} \\
 &= \frac{-9}{-9x} \\
 &= x \\
 f^{-1}(f(x)) &= \frac{-2\left(\frac{x-7}{x+2}\right) - 7}{\frac{x-7}{x+2} - 1} \\
 &= \frac{-2x+14-7(x+2)}{x-7-(x+2)} \\
 &= \frac{-9x-9}{-9} \\
 &= x
 \end{aligned}$$

96. The inverse function exists.

97. The inverse function does not exist since it does not pass the horizontal line test.

98. The inverse function exists.

99. The inverse function does not exist since it does not pass the horizontal line test.

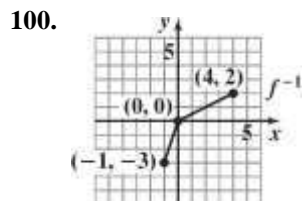

101. $f(x) = 1 - x^2$
 $y = 1 - x^2$
 $x = 1 - y^2$
 $y^2 = 1 - x$

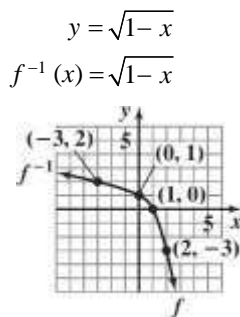

102. $f(x) = \sqrt{x} + 1$
 $y = \sqrt{x} + 1$
 $x = \sqrt{y} + 1$
 $x - 1 = \sqrt{y}$
 $(x - 1)^2 = y$
 $f^{-1}(x) = (x - 1)^2, x \geq 1$

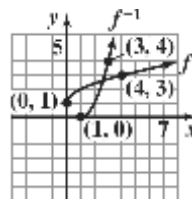

103. $d = \sqrt{[3 - (-2)]^2 + [9 - (-3)]^2}$
 $= \sqrt{5^2 + 12^2}$
 $= \sqrt{25 + 144}$
 $= \sqrt{169}$
 $= 13$

104. $d = \sqrt{[-2 - (-4)]^2 + (5 - 3)^2}$
 $= \sqrt{2^2 + 2^2}$
 $= \sqrt{4 + 4}$
 $= \sqrt{8}$
 $= 2\sqrt{2}$
 ≈ 2.83

105. $\left(\frac{2 + (-12)}{2}, \frac{6 + 4}{2}\right) = \left(\frac{-10}{2}, \frac{10}{2}\right) = (-5, 5)$

106. $\left(\left|\frac{4+(-15)}{2}, \frac{-6+2}{2}\right|\right) = \left(\frac{-11}{2}, \frac{-4}{2}\right) = \left(\frac{-11}{2}, -2\right)$

107. $x^2 + y^2 = 3^2$
 $x^2 + y^2 = 9$

108. $(x - (-2))^2 + (y - 4)^2 = 6^2$
 $(x + 2)^2 + (y - 4)^2 = 36$

109. center: (0, 0); radius: 1

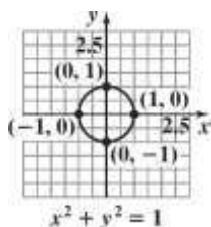

domain: $[-1, 1]$
 range: $[-1, 1]$

110. center: (-2, 3); radius: 3

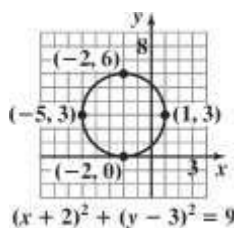

domain: $[-5, 1]$
 range: $[0, 6]$

111. $x^2 + y^2 - 4x + 2y - 4 = 0$
 $x^2 - 4x + y^2 + 2y = 4$
 $x^2 - 4x + 4 + y^2 + 2y + 1 = 4 + 4 + 1$
 $(x - 2)^2 + (y + 1)^2 = 9$
 center: (2, -1); radius: 3

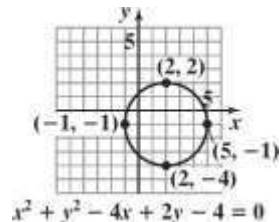

domain: $[-1, 5]$
 range: $[-4, 2]$

Chapter 2 Test

1. (b), (c), and (d) are not functions.
2. a. $f(4) - f(-3) = 3 - (-2) = 5$
 b. domain: $(-5, 6]$
 c. range: $[-4, 5]$
 d. increasing: $(-1, 2)$
 e. decreasing: $(-5, -1)$ or $(2, 6)$
 f. $2, f(2) = 5$
 g. $(-1, -4)$
 h. x-intercepts: $-4, 1,$ and $5.$
 i. y-intercept: -3
3. a. $-2, 2$
 b. $-1, 1$
 c. 0
 d. even; $f(-x) = f(x)$
 e. no; f fails the horizontal line test
 f. $f(0)$ is a relative minimum.

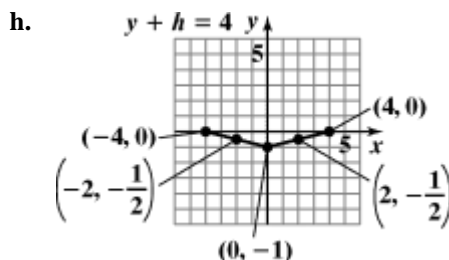
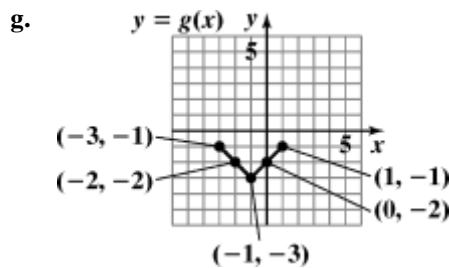

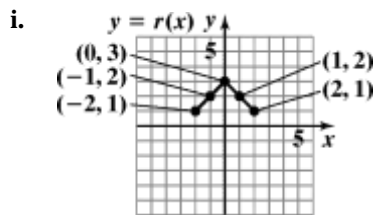

j.
$$\frac{f(x_2) - f(x_1)}{x_2 - x_1} = \frac{-1 - 0}{1 - (-2)} = -\frac{1}{3}$$

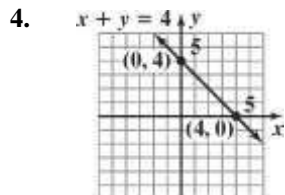

domain: $(-\infty, \infty)$
range: $(-\infty, \infty)$

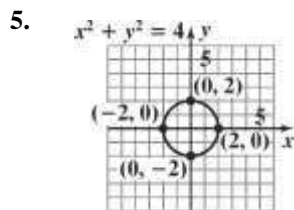

domain: $[-2, 2]$
range: $[-2, 2]$

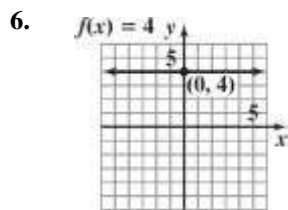

domain: $(-\infty, \infty)$
range: $\{4\}$

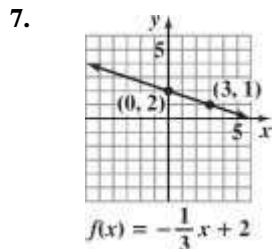

domain: $(-\infty, \infty)$
range: $(-\infty, \infty)$

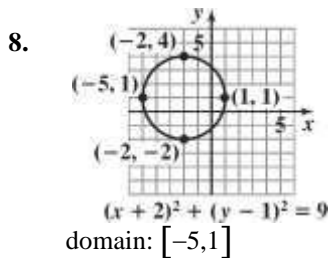

domain: $[-5, 1]$

range: $[-2, 4]$

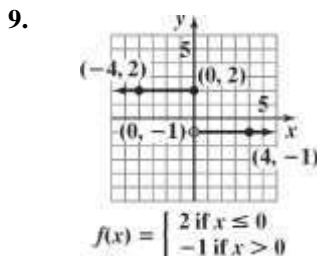

domain: $(-\infty, \infty)$

range: $\{-1, 2\}$

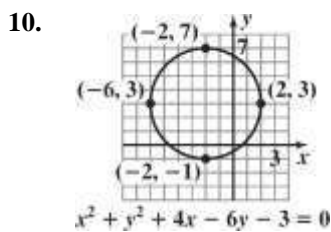

domain: $[-6, 2]$

range: $[-1, 7]$

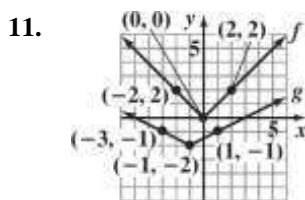

domain of f : $(-\infty, \infty)$

range of f : $[0, \infty)$

domain of g : $(-\infty, \infty)$

range of g : $[-2, \infty)$

12.

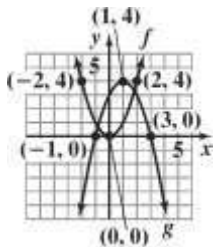

domain of f : $(-\infty, \infty)$

range of f : $[0, \infty)$

domain of g : $(-\infty, \infty)$

range of g : $(-\infty, 4]$

13.

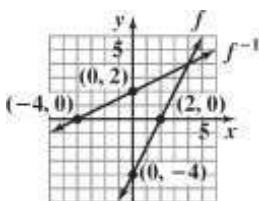

domain of f : $(-\infty, \infty)$

range of f : $(-\infty, \infty)$

domain of f^{-1} : $(-\infty, \infty)$

range of f^{-1} : $(-\infty, \infty)$

14.

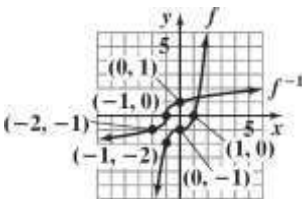

domain of f : $(-\infty, \infty)$

range of f : $(-\infty, \infty)$

domain of f^{-1} : $(-\infty, \infty)$

range of f^{-1} : $(-\infty, \infty)$

15.

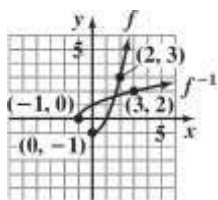

domain of f : $[0, \infty)$

range of f : $[-1, \infty)$

domain of f^{-1} : $[-1, \infty)$

16. $f(x) = x^2 - x - 4$

$$\begin{aligned} f(x-1) &= (x-1)^2 - (x-1) - 4 \\ &= x^2 - 2x + 1 - x + 1 - 4 \\ &= x^2 - 3x - 2 \end{aligned}$$

17. $\frac{f(x+h) - f(x)}{h}$

$$\begin{aligned} &= \frac{(x+h)^2 - (x+h) - 4 - (x^2 - x - 4)}{h} \\ &= \frac{x^2 + 2xh + h^2 - x - h - 4 - x^2 + x + 4}{h} \\ &= \frac{2xh + h^2 - h}{h} \\ &= \frac{h(2x + h - 1)}{h} \\ &= 2x + h - 1 \end{aligned}$$

18. $(g \circ f)(x) = 2x - 6 - (x^2 - x - 4)$

$$\begin{aligned} &= 2x - 6 - x^2 + x + 4 \\ &= -x^2 + 3x - 2 \end{aligned}$$

19. $\left(\frac{f}{g}\right)(x) = \frac{x^2 - x - 4}{2x - 6}$

domain: $(-\infty, 3) \cup (3, \infty)$

20. $(f \circ g)(x) = f(g(x))$

$$\begin{aligned} &= (2x - 6)^2 - (2x - 6) - 4 \\ &= 4x^2 - 24x + 36 - 2x + 6 - 4 \\ &= 4x^2 - 26x + 38 \end{aligned}$$

21. $(g \circ f)(x) = g(f(x))$

$$= 2(x^2 - x - 4) - 6$$

range of f^{-1} : $[0, \infty)$

22.

Chapter 2 Functions and Graphs

$$\begin{aligned} &= \\ &2x^2 \\ &- 2x \\ &- 8 \\ &- 6 \\ &= \\ &2x^2 \\ &- 2x \\ &- 14 \end{aligned}$$

$$\begin{aligned} g(f(-1)) &= \\ 2((-1)^2 - & \\ (-1) - 4) - 6 & \\ &= 2 \\ (1 + & \\ 1 - & \\ 4) & \\ - 6 & \\ = 2 & \\ (-2 & \\) - & \\ 6 & \\ = & \\ -4 & \\ - 6 & \\ = & \\ -10 & \end{aligned}$$

23. $f(x) = x^2 - x - 4$

$$f(-x) = (-x)^2 - (-x) - 4$$

$$= x^2 + x - 4$$

f is neither even nor odd.

24. Test for symmetry with respect to the y -axis.

$$x^2 + y^3 = 7$$

$$(-x)^2 + y^3 = 7$$

$$x^2 + y^3 = 7$$

The resulting equation is equivalent to the original. Thus, the graph is symmetric with respect to the y -axis.

Test for symmetry with respect to the x -axis.

$$x^2 + y^3 = 7$$

$$x^2 + (-y)^3 = 7$$

$$x^2 - y^3 = 7$$

The resulting equation is not equivalent to the original. Thus, the graph is not symmetric with respect to the x -axis.

Test for symmetry with respect to the origin.

$$x^2 + y^3 = 7$$

$$(-x)^2 + (-y)^3 = 7$$

$$x^2 - y^3 = 7$$

The resulting equation is not equivalent to the original. Thus, the graph is not symmetric with respect to the origin.

25. $m = \frac{-8-1}{-1-2} = \frac{-9}{-3} = 3$

point-slope form: $y - 1 = 3(x - 2)$

or $y + 8 = 3(x + 1)$

slope-intercept form: $y = 3x - 5$

26. $y = -\frac{1}{4}x + 5$ so $m = 4$

point-slope form: $y - 6 = 4(x + 4)$

slope-intercept form: $y = 4x + 22$

27. Write $4x + 2y - 5 = 0$ in slope intercept form.

$$4x + 2y - 5 = 0$$

$$2y = -4x + 5$$

$$y = -2x + \frac{5}{2}$$

The slope of the parallel line is -2 , thus the slope of

the desired line is $m = -2$.

$$y - y_1 = m(x - x_1)$$

$$y - (-10) = -2(x - (-7))$$

$$y + 10 = -2(x + 7)$$

$$y + 10 = -2x - 14$$

$$2x + y + 24 = 0$$

28. a. Find slope: $m = \frac{25.8 - 24.6}{20 - 10} = \frac{1.2}{10} = 0.12$

point-slope form:

$$y - y_1 = m(x - x_1)$$

$$y - 24.6 = 0.12(x - 10)$$

b. slope-intercept form:

$$y - 24.6 = 0.12(x - 10)$$

$$y - 24.6 = 0.12x - 1.2$$

$$y = 0.12x + 23.4$$

$$f(x) = 0.12x + 23.4$$

c. $f(x) = 0.12x + 23.4$

$$= 0.12(40) + 23.4$$

$$= 28.2$$

According to the model, 28.2% of U.S. households will be one-person households in 2020.

29. $\frac{3(10)^2 - 5 - [3(6)^2 - 5]}{10 - 6}$
 $= \frac{205 - 103}{4}$
 $= \frac{192}{4}$
 $= 48$

30. $g(-1) = 3 - (-1) = 4$

$$g(7) = \sqrt{7-3} = \sqrt{4} = 2$$

31. The denominator is zero when $x = 1$ or $x = -5$.

$$\text{domain: } (-\infty, -5) \cup (-5, 1) \cup (1, \infty)$$

32. The expressions under each radical must not be negative.

$$x + 5 \geq 0 \quad \text{and} \quad x - 1 \geq 0$$

$$x \geq -5 \quad \quad \quad x \geq 1$$

$$\text{domain: } [1, \infty)$$

10. $\frac{x}{4} - 3 \leq \frac{x}{2} + 2$

$$\frac{2}{4} \left(\frac{x}{2} - 3 \right) \leq \frac{2}{4} \left(\frac{x}{2} + 2 \right)$$

$$\left(\frac{x}{2} - 3 \right) \leq \left(\frac{x}{2} + 2 \right)$$

$$2x - 12 \leq x + 8$$

$$x \leq 20$$

The solution set is $(-\infty, 20]$.

11.

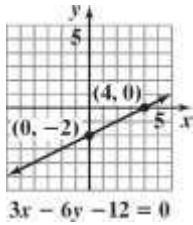

domain: $(-\infty, \infty)$

range: $(-\infty, \infty)$

12.

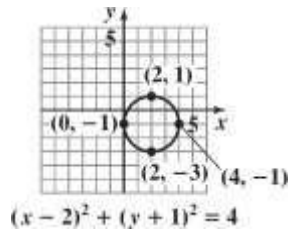

domain: $[0, 4]$

range: $[-3, 1]$

13.

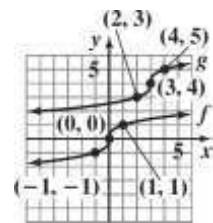

domain of f : $(-\infty, \infty)$

range of f : $(-\infty, \infty)$

domain of g : $(-\infty, \infty)$

range of g : $(-\infty, \infty)$

14.

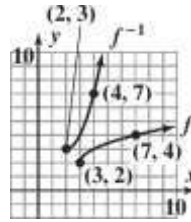

domain of f : $[3, \infty)$

range of f : $[2, \infty)$

domain of f^{-1} : $[2, \infty)$

range of f^{-1} : $[3, \infty)$

15.
$$\frac{f(x+h) - f(x)}{h}$$

$$= \frac{(4 - (x+h)^2) - (4 - x^2)}{h}$$

$$= \frac{4 - (x^2 + 2xh + h^2) - (4 - x^2)}{h}$$

$$= \frac{4 - x^2 - 2xh - h^2 - 4 + x^2}{h}$$

$$= \frac{-2xh - h^2}{h}$$

$$= \frac{h(-2x - h)}{h}$$

$$= -2x - h$$

16. $(f \circ g)(x) = f(g(x))$

$$(f \circ g)(x) = f(x+5)$$

$$0 = 4 - (x+5)^2$$

$$0 = 4 - (x^2 + 10x + 25)$$

$$0 = 4 - x^2 - 10x - 25$$

$$0 = -x^2 - 10x - 21$$

$$0 = x^2 + 10x + 21$$

$$0 = (x+7)(x+3)$$

The value of $(f \circ g)(x)$ will be 0 when $x = -3$ or $x = -7$.

1 1

17. $y = -\frac{x}{4} + 5$, so $m = -\frac{1}{4}$

point-slope form: $y - 5 = -\frac{1}{4}(x + 2)$

slope-intercept form: $y = -\frac{1}{4}x + 5 - \frac{1}{2}$

general form: $4x - y + 13 = 0$

18. $0.07x + 0.09(6000 - x) = 510$

$$0.07x + 540 - 0.09x = 510$$

$$-0.02x = -30$$

$$x = 1500$$

$$6000 - x = 4500$$

\$1500 was invested at 7% and \$4500 was invested at 9%.

19. $200 + 0.05x = .15x$

$$200 = 0.10x$$

$$2000 = x$$

For \$2000 in sales, the earnings will be the same.

20. width = w

$$\text{length} = 2w + 2$$

$$2(2w + 2) + 2w = 22$$

$$4w + 4 + 2w = 22$$

$$6w = 18$$

$$w = 3$$

$$2w + 2 = 8$$

The garden is 3 feet by 8 feet.