

Solution Manual for Computer Security Principles and Practice 3rd Edition by Stallings ISBN 0133773922 9780133773927

Full link download:

Solution Manual:

<https://testbankpack.com/p/solution-manual-for-computer-security-principles-and-practice-3rd-edition-by-stallings-isbn-0133773922-9780133773927/>

Test Bank:

<https://testbankpack.com/p/test-bank-for-computer-security-principles-and-practice-3rd-edition-by-stallings-isbn-0133773922-9780133773927/>

ANSWERS TO QUESTIONS

Confidentiality, Integrity and Availability are three key objectives that form the heart of computer security. These three are often referred to as the CIA triad.

Data integrity assures that information and programs are changed only in a specified and authorized manner whereas system integrity assures that a system performs its intended function in an unimpaired manner, free from deliberate or inadvertent unauthorized manipulation of the system.

Passive attacks have to do with eavesdropping on, or monitoring, transmissions. Electronic mail, file transfers, and client/server exchanges are examples of transmissions that can be monitored. Active attacks include the modification of transmitted data and attempts to gain unauthorized access to computer systems.

Passive attacks: release of message contents and traffic analysis. Active attacks: masquerade, replay, modification of messages, and denial of service.

Authentication: The assurance that the communicating entity is the one that it claims to be.

Access control: The prevention of unauthorized use of a resource (i.e., this service controls who can have access to a resource, under what conditions access can occur, and what those accessing the resource are allowed to do).

Data confidentiality: The protection of data from unauthorized disclosure.

Data integrity: The assurance that data received are exactly as sent by an authorized entity (i.e., contain no modification, insertion, deletion, or replay).

Nonrepudiation: Provides protection against denial by one of the entities involved in a communication of having participated in all or part of the communication.

Availability service: The property of a system or a system resource being accessible and usable upon demand by an authorized system entity, according to performance specifications for the system (i.e., a system is available if it provides services according to the system design whenever users request them).

Network attack surface refers to vulnerabilities over an enterprise network, wide- area network or the Internet whereas Software attack surface refers to vulnerabilities in application, utility or operating system code.

ANSWERS TO PROBLEMS

Apart from the card and USN, if the student needs to enter a pass key to access the information, then the system must keep the pass key confidential, both in the host system and during transmission for a transaction. It must protect the integrity of student records. Availability of the host system is important for maintaining the reputation of the Institution. The availability of SIS machines is of less concern.

The system has high requirements for integrity on individual data packet, as lasting damage can incur by occasionally losing a data packet. The integrity of routing algorithm and routing tables is also critical. Without these, the routing function would be defeated. A network routing system must also preserve the confidentiality of individual data packets, preventing one from accessing the contents of another.

- a. The system will have to assure confidentiality if it is being used to publish corporate proprietary material. The system will have to assure integrity if it is being used to laws or regulations. The system will have to assure availability if it is being used to publish a daily paper. Example from [NRC91].

a. An organization managing public information on its web server determines that there is no potential impact from a loss of confidentiality (i.e., confidentiality requirements are not applicable), a moderate potential impact from a loss of integrity, and a moderate potential impact from a loss of availability.

A law enforcement organization managing extremely sensitive investigative information determines that the potential impact from a loss of confidentiality is high, the potential impact from a loss of integrity is moderate, and the potential impact from a loss of availability is moderate.

A financial organization managing routine administrative information (not privacy-related information) determines that the potential

impact from a loss of confidentiality is low, the potential impact from a loss of integrity is low, and the potential impact from a loss of availability is low.

The management within the contracting organization determines that: (i) for the sensitive contract information, the potential impact from a loss of confidentiality is moderate, the potential impact from a loss of integrity is moderate, and the potential impact from a loss of availability is low; and (ii) for the routine administrative information (non-privacy-related information), the potential impact from a loss of confidentiality is low, the potential impact from a loss of integrity is low, and the potential impact from a loss of availability is low.

The management at the power plant determines that: (i) for the sensor data being acquired by the SCADA system, there is no potential impact from a loss of confidentiality, a high potential impact from a loss of integrity, and a high potential impact from a loss of availability; and (ii) for the administrative information being processed by the system, there is a low potential impact from a loss of confidentiality, a low potential impact from a loss of integrity, and a low potential impact from a loss of availability. Examples from FIPS 199.

a. At first glance, this code looks fine, but what happens if `IsAccessAllowed` fails? For example, what happens if the system runs out of memory, or object handles, when this function is called? The user can execute the privileged task because the function might return an error such as `ERROR NOT ENOUGH MEMORY`.

```
b. x  
DWORD dwRet = IsAccessAllowed(...); if (dwRet == NO_ERROR) {  
// Secure check OK.  
// Perform task.  
} else {  
// Security check failed.  
// Inform user that access is denied.  
}
```

In this case, if the call to `IsAccessAllowed` fails for any reason, the user is denied access to the privileged operation.

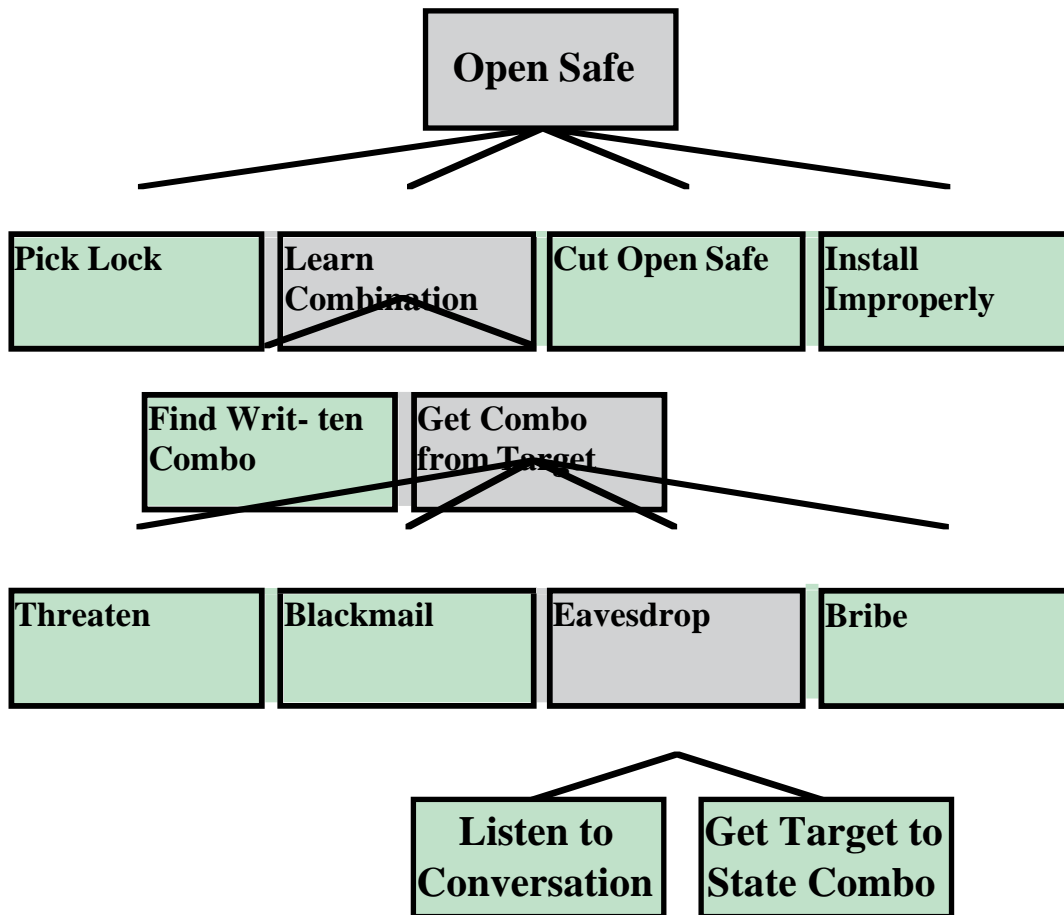

We present the tree in text form; call the company X:

Survivability Compromise: Disclosure of X proprietary secrets OR

1. Physically scavenge discarded items from X

OR

1. Inspect dumpster content on-site
2. Inspect refuse after removal from site

Monitor emanations from X machines

AND

1. Survey physical perimeter to determine optimal monitoring position

Acquire necessary monitoring equipment

Setup monitoring site

Monitor emanations from site

Recruit help of trusted X insider OR

1. Plant spy as trusted insider

Use existing trusted insider

Physically access X networks or machines

OR

1. Get physical, on-site access to Intranet

Get physical access to external machines

Attack X intranet using its connections with Internet

OR

1. Monitor communications over Internet for leakage

Get trusted process to send sensitive information to attacker over Internet

Gain privileged access to Web server

Attack X intranet using its connections with public telephone network (PTN) OR

1. Monitor communications over PTN for leakage of sensitive information

Gain privileged access to machines on intranet connected via Internet

CHAPTER 2 CRYPTOGRAPHIC TOOLS

ANSWERS TO QUESTIONS

Cryptanalysis, one of the approaches to attack symmetric encryption, relies on the nature of the encryption algorithm plus some knowledge of the general characteristics of the plaintext or even some sample plaintext-ciphertext pairs.

Brute-force attack, on the other hand, tries every possible key on a piece of ciphertext until an intelligible translation into plaintext is obtained.

In block cipher encryption, the input is processed one block of elements at a time, producing an output block for each input block whereas stream encryption processes the input elements continuously, producing output one element at a time, as it goes along.

(1) a strong encryption algorithm; (2) Sender and receiver must have obtained copies of the secret key in a secure fashion and must keep the key secure.

The two important aspects of data authentication are: (i) to verify that the contents of the message have not been altered and (ii) that the source is authentic.

One-way hash function is an alternative to Message Authentication Code (MAC). Like MAC, one-way hash function too accepts a variable-size message as input and produces a fixed-size message digest as output. It differs from MAC in several aspects, for instance, it does not take a secret key as input like MAC. Moreover, the messages are typically padded out to an integer multiple of some fixed length (e.g., 1024 bits) and the padding includes the value of the length of the original message in bits. The length field is a security measure to increase the difficulty for an attacker to produce an alternative message with the same hash value.

(a) A hash code is computed from the source message, encrypted using symmetric encryption and a secret key, and appended to the message. At the receiver, the same hash code is computed. The incoming code is decrypted using the same key and compared with the computed hash code. **(b)** This is the same procedure as in (a) except that public-key encryption is used; the sender encrypts the hash code with the sender's private key, and the receiver decrypts the hash code with the sender's public key. **(c)** A secret value is appended to a message and then a hash code is calculated using the message plus secret value as input. Then the message (without the secret value) and the hash code are transmitted. The receiver appends the same secret value to the message and computes the hash value over the message plus secret value. This is then compared to the received hash code.

1. H can be applied to a block of data of any size.

H produces a fixed-length output.

$H(x)$ is relatively easy to compute for any given x , making both hardware and software implementations practical.

For any given value h , it is computationally infeasible to find x such that $H(x) = h$.

For any given block x , it is computationally infeasible to find $y \neq x$ with $H(y) = H(x)$.

It is computationally infeasible to find any pair (x, y) such that $H(x) = H(y)$.

Plaintext: This is the readable message or data that is fed into the algorithm as input. **Encryption algorithm:** The encryption algorithm performs various transformations on the plaintext. **Public and private keys:** This is a pair of keys that have been selected so that if one is used for encryption, the other is used for decryption. The exact transformations performed by the encryption algorithm depend on the public or private key that is provided as input. **Ciphertext:** This is the scrambled message produced as output. It depends on the plaintext and the key. For a given message, two different keys will produce two different ciphertexts. **Decryption algorithm:** This algorithm accepts the ciphertext and the matching key and produces the original plaintext.

Encryption/decryption: The sender encrypts a message with the recipient's public key. **Digital signature:** The sender "signs" a message with its private key. Signing is achieved by a cryptographic algorithm applied to the message or to a small block of data that is a function of the message. **Key exchange:** Two sides cooperate to exchange a session key. Several different approaches are possible, involving the private key(s) of one or both parties.

The key used in conventional encryption is typically referred to as a **secret key**. The two keys used for public-key encryption are referred to as the **public key** and the **private key**.

No, digital signatures do not provide confidentiality, i.e., the message being sent is safe from alteration but not safe from eavesdropping.

A **public-key certificate** consists of a public key plus a User ID of the key owner, with the whole block signed by a trusted third party. Typically, the third party is a certificate authority (CA) that is trusted by the user community, such as a government agency or a financial institution.

Several different approaches are possible, involving the private key(s) of one or both parties. One approach is Diffie-Hellman key exchange. Another approach is for the sender to encrypt a secret key with the recipient's public key.

ANSWERS TO PROBLEMS

Yes. The eavesdropper is left with two strings, one sent in each direction, and their XOR is the secret key.

a.

2 8 10 7 9 6 3 1 4 5
 C R Y P T O G A H I

B	E	A	T	T	H	E	T	H	I
R	D	P	I	L	L	A	R	F	R
O	M	T	H	E	L	E	F	T	O
U	T	S	I	D	E	T	H	E	L
Y	C	E	U	M	T	H	E	A	T
R	E	T	O	N	I	G	H	T	A
T	S	E	V	E	N	I	F	Y	O
U	A	R	E	D	I	S	T	R	U
S	T	F	U	L	B	R	I	N	G
T	W	O	F	R	I	E	N	D	S

4 2 8 10 5 6 3 7 1 9
 N E T W O R K S C U

T	R	F	H	E	H	F	T	I	N
B	R	O	U	Y	R	T	U	S	T
E	A	E	T	H	G	I	S	R	E
H	F	T	E	A	T	Y	R	N	D
I	R	O	L	T	A	O	U	G	S
H	L	L	E	T	I	N	I	B	I
T	I	H	I	U	O	V	E	U	F
E	D	M	T	C	E	S	A	T	W
T	L	E	D	M	N	E	D	L	R
A	P	T	S	E	T	E	R	F	O

ISRNG BUTLF RRAFR LIDL PFTIYO NVSEE TBEHI HTETA EYHAT
 TUCME HRGTA IOENT TUSRU IEADR FOETO LHMET NTEDS IFWRO
 HUTEL EITDS

The two matrices are used in reverse order. First, the ciphertext is laid out in columns in the second matrix, taking into account the order dictated by the second memory word. Then, the contents of the second matrix are read left to right, top to bottom and laid out in columns in the first matrix, taking into account the order dictated by the first memory word. The plaintext is then read left to right, top to bottom.

Although this is a weak method, it may have use with time-sensitive information and an adversary without immediate access to good cryptanalysis (e.g., tactical use). Plus it doesn't require anything more than paper and pencil, and can be easily remembered.

a. Let $-X$ be the additive inverse of X . That is $-X + X = 0$. Then: +
 $P = (C + K_1) - K_0$

b. First, calculate $-C'$. Then $-C' = (P' \sqcup K_0) - (-K_1)$. We then have: +
 $C - C' = (P \sqcup K_0) + (P' \sqcup K_0)$

However, the operations $+$ and \sqcup are not associative or distributive with one another, so it is not possible to solve this equation for K_0 .

a. The constants ensure that encryption/decryption in each round is different.

First two rounds:
 L_0 R_0

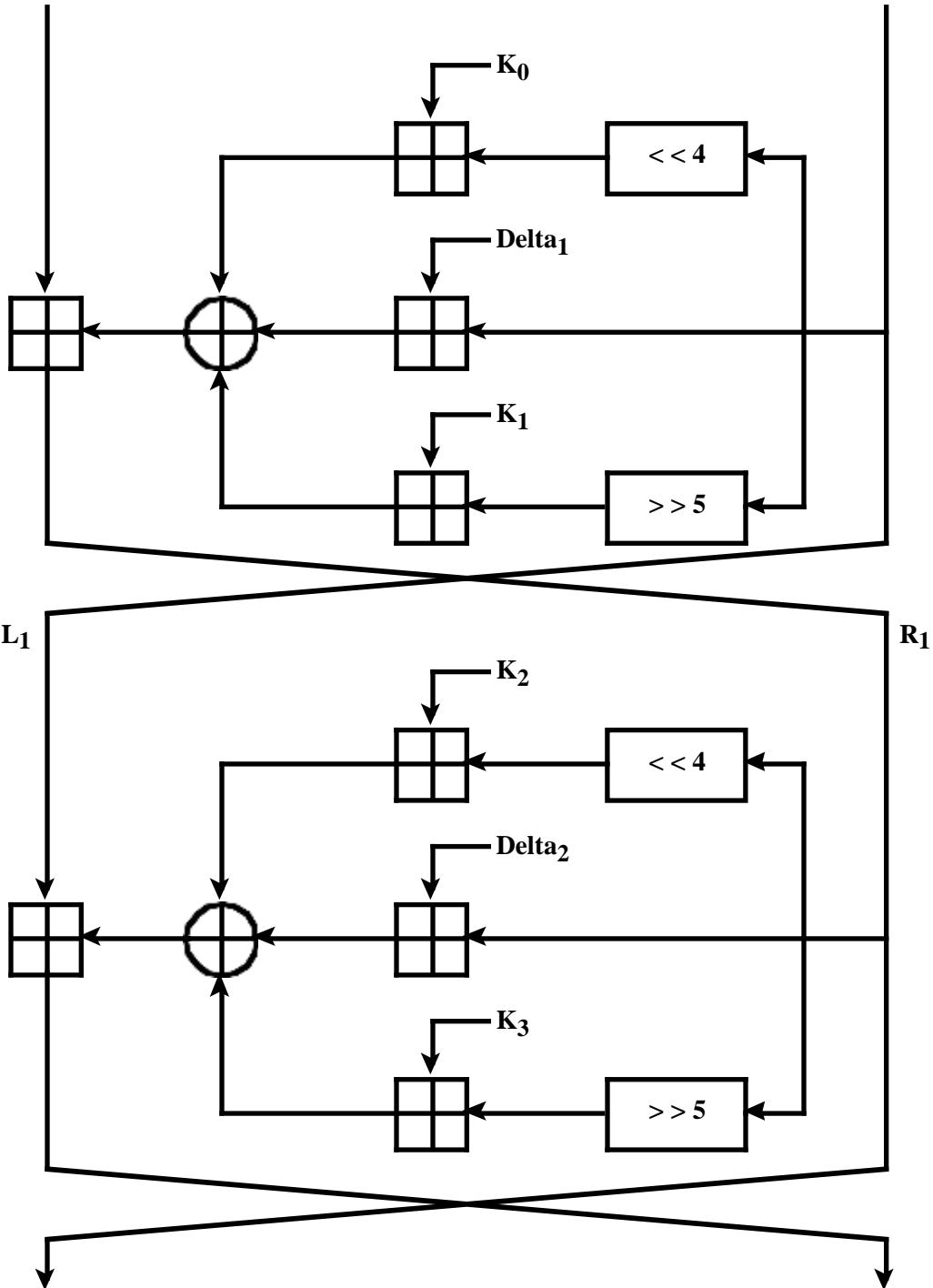

L_2 R_2

•
•
•

•
•
•

First, let's define the encryption process:

$$\begin{array}{l}
 L_2 = L_0 \quad R_2 = R_0 \\
 \boxed{R_0} \lll 4 \\
 \boxed{L_2} \lll 4 \\
 \boxed{K_0} \lrcorner [R_0 \\
 \boxed{+} \lrcorner 2 \\
 K_2] \boxed{+} \lrcorner \boxed{R_0} \ggg 5 \\
 \boxed{+} \lrcorner \boxed{L_2} \ggg 5 \\
 \boxed{K_1} \lrcorner \boxed{+}
 \end{array}$$

Now the decryption process. The input is the ciphertext (L₂, R₂), and the output is the plaintext (L₀, R₀). Decryption is essentially the same

as encryption, with the subkeys and delta values applied in reverse order. Also note that it is not necessary to use subtraction because there is an even number of additions in each equation.

$$\begin{array}{l}
 R_0 = R_2 \quad L_0 = L_2 \\
 \boxed{L_2} \lll 4 \\
 \boxed{R_0} \lll 4 \\
 K_2] \lrcorner [L_2 \quad K_0] \boxed{+} \lrcorner \boxed{L_2} \ggg 5 \\
 \boxed{+} \lrcorner R_0 \\
 \boxed{+} \\
 \boxed{K_1} \lrcorner \boxed{+} \lrcorner \boxed{R_0} \ggg 5 \\
 \boxed{K_1} \lrcorner \boxed{+}
 \end{array}$$

d.
L₀ R₀

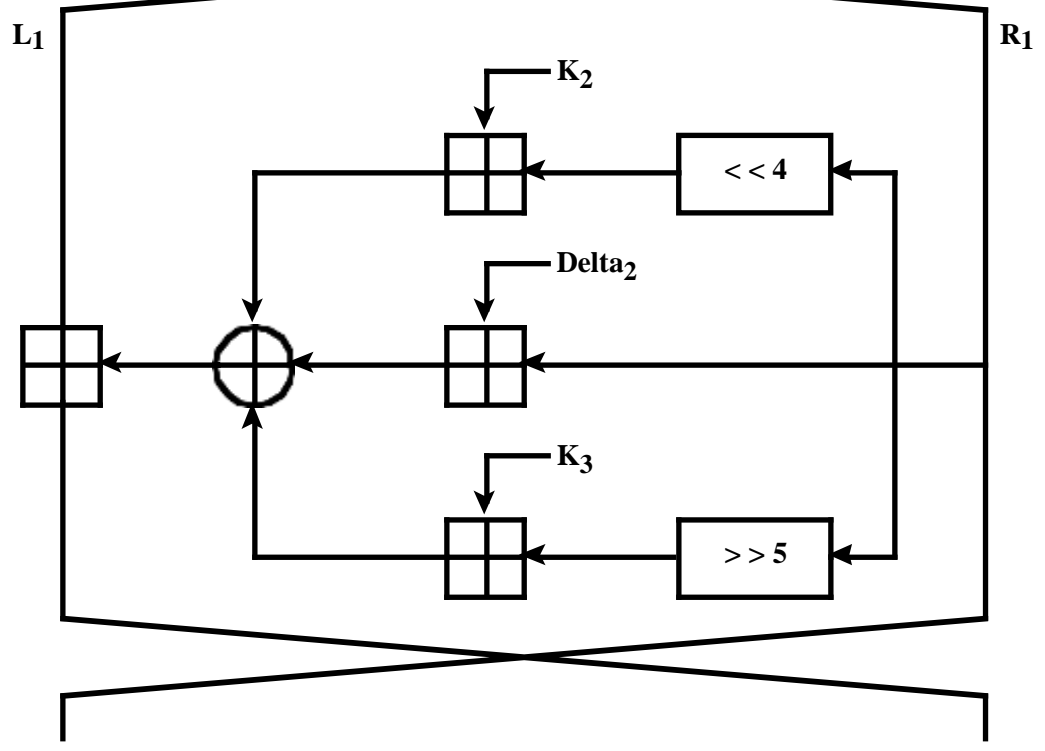
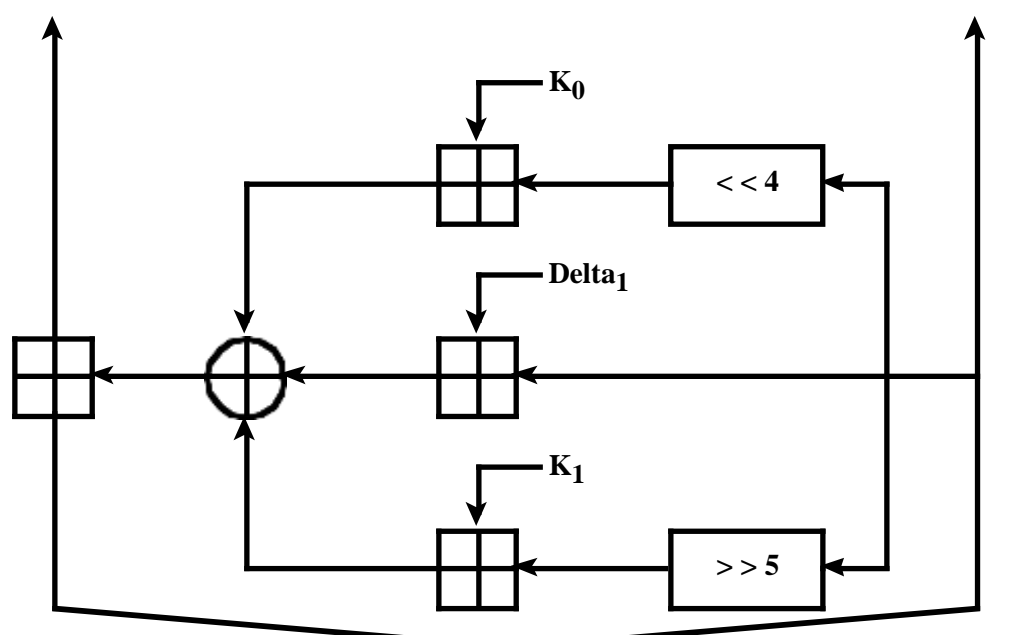

L₂ R₂

