

Full download at:

<https://testbankpack.com/p/solution-manual-for-data-communications-and-networking-5th-edition-by-forouzan-isbn-0073376221-9780073376226/>

CHAPTER 2: PRACTICE SET

Questions

- Q2-1.** To make the communication bidirectional, each layer needs to be able to provide two opposite tasks, one in each direction.
- Q2-2.** The link-layer switch is normally involved in the first two layers of the TCP/ IP protocol suite:
- a. the physical layer,
 - b. and the data-link layer.
- Q2-3.** The router is involved in:
- a. three physical layers,
 - b. three data-link layers,
 - c. and only one network layer.
- Q2-4.** The identical objects are the two messages: one sent and one received.
- Q2-5.**
- a. At the application layer, the unit of data is a *message*.
 - b. At the network layer, the unit of data is a *datagram*.
 - c. At the data-link layer, the unit of data is a *frame*.
- Q2-6.** A frame is a link -layer data unit. It encapsulates a data unit coming from the network layer. In this case, the data unit is a *datagram*.
- Q2-7.** A user datagram is a transport- layer data unit. It decapsulates a data unit going to the application layer. In this case, the data unit is a message.

- Q2-8.** The data unit should belong to layer 4. In this case, it is a user datagram.
- Q2-9.** We mentioned HTTP, FTP, SMTP, SNMP, TELNET, SSH, and DNS.
- Q2-10.** The transport-layer packet needs to include two port numbers: source and destination port numbers. The transport-layer header needs to be at least 32 bits (four bytes) long, but we will see in Chapter 24 that the header size is normally much longer because we need to include other pieces of information.
- Q2-11.**
- a. At the application layer, we normally use a name to define the destination-computer name and the name of the file we need to access. An example is *something@somewhere.com*.
 - b. At the network layer, we use two logical addresses (source and destination) to define the source and destination computers. These addresses are unique universally.
 - c. At the data-link layer, we use two link-layer addresses (source and destination) to define the source and destination connections to the link.
- Q2-12.** The answer is no. Multiplexing/demultiplexing at the transport layer does not mean combining several upper-layer packets (from the same or different applications) into one transport-layer packet. It only means that each of the transport-layer protocols (such as TCP or UDP) can carry a packet from any application-layer protocol that needs its service. However, a transport-layer packet can carry one, and only one, packet from an application-layer protocol. For example, UDP can carry a message from FTP in one user datagram and a message from HTTP in another user datagram.
- Q2-13.** The application layer is the top layer in the suite; it does not provide services to any layer, which means multiplexing/demultiplexing does not exist for this layer.
- Q2-14.** We do not need a link-layer switch because the communication in this case is automatically one-to-one. A link-layer switch is needed when we need to change a one-to-many communication to a one-to-one.
- Q2-15.** We do not need a router in this case because a router is needed when there is more than one path between the two hosts; the router is responsible for choosing the best path at each moment.

Problems

- P2-1.** The services provided in part a and part b are the opposite of each other.

- a. Layer 1 takes the ciphertext from layer 2, inserts (encapsulates) it in an envelope and sends it.
- b. Layer 1 receives the mail, removes (decapsulates) the ciphertext from the envelope and delivers it to layer 2.

P2-2. The services provided in part a and part b are the opposite of each other.

- a. Layer 2 takes the plaintext from layer 3, encrypts it, and delivers it to layer 1.
- b. Layer 2 takes the ciphertext from layer 1, decrypts it, and delivers it to layer 3.

P2-3. In 10 years, the number of hosts becomes about six times (1.20^{10} H 6.19) the number in 2010. This means the number of hosts connected to the Internet is more than three billion.

P2-4. The system transmits 150 bytes for a 100-byte message. The efficiency is $100/150$ or 66.66%.

P2-5. The advantage of using large packets is less overhead. When using large packets, the number of packets to be sent for a huge file becomes small. Since we are adding three headers to each packet, we are sending fewer extra bytes than in the case in which the number of packets is large. The disadvantage manifests itself when a packet is lost or corrupted during the transmission; we need to resend a large amount of data.

P2-6.

- a. The *network layer* is responsible for route determination.
- b. The *physical layer* is the only layer that is connected to the transmission media.
- c. The *application layer* provides services for the end users.

P2-7.

- a. User datagrams are created at the *transport layer*.
- b. The *data-link layer* is responsible for handling frames between adjacent nodes.
- c. The *physical layer* is responsible for transforming bits to electromagnetic signals.

P2-8. There should be an upper-layer identifier in the header of the IP protocol to define to which upper-layer protocol the encapsulated packet belongs. The identifier is called the *protocol field* (See Figure 19.2 in Chapter 19).

P2-9. The following shows the situation. If we think about multiplexing as *many-to-one* and demultiplexing as *one-to-many*, we have demultiplexing at the source node and multiplexing at the destination node in the data-link layer. However, some purists call these two *inverse multiplexing* and *inverse demultiplexing*.

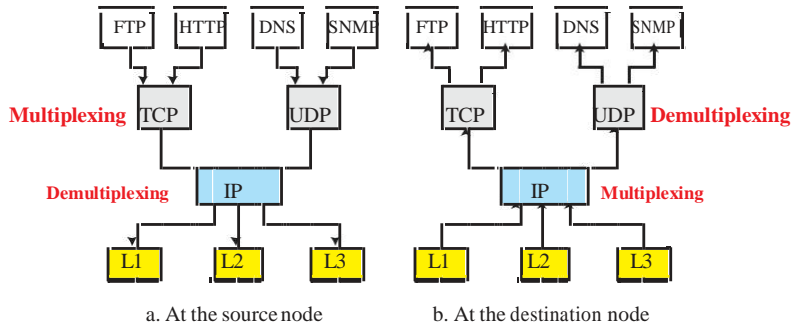

P2-10. Every time any packet at any layer is encapsulated inside another packet at the same layer, we can think of this as a new layer being added under that layer. The following shows the new suite.



P2-11. The following shows the layers. Note that we have not shown the security checking that you need to pass through because it does not have the counterpart when you arrive. It must be included in baggage/checking layer.

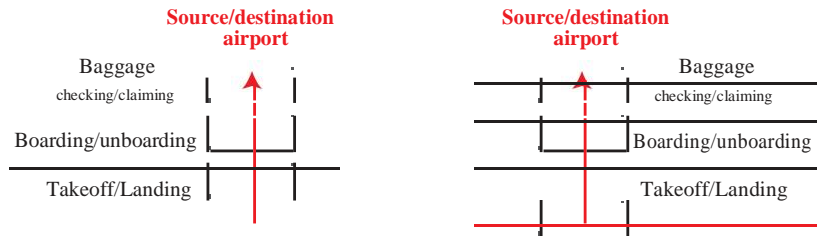

- P2-12.** The following shows the position of the presentation layer. The new layer is at the same position as the presentation layer in the OSI model if we ignore the session layer.

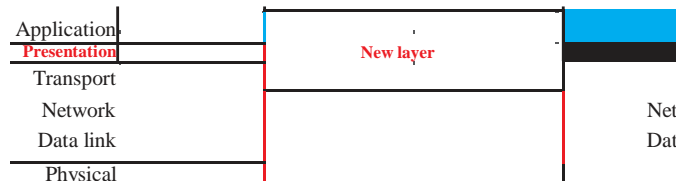

- P2-13.** The only two layers that need to be changed are the data-link layer and the physical layer. The new hardware and software need to be installed in all host, routers, and link-layer switches. As long as the new data-link layer can encapsulate and decapsulate datagrams from the network layer, there is no need to change any protocol in the upper three layers. This is one of the characteristics of the protocol layering.
- P2-14.** The reason for having several protocols in a layer is to provide different services to the upper-layer protocols. The services provided by UDP are different from the services provided by TCP. When we write an application program, we need to first define which transport-layer protocol is supposed to give services to this application program. Note that this does not violate the principle of layer independence. The independency of a layer means that we can change a protocol in a layer as long as the new one gives the same services as the old one. This does not mean that we can replace UDP by TCP, because they provide different services.
- P2-15.** The following shows the layers and the flow of data. Note that each host is involved in five layers, each switch in two layers, and each router in three layers.

