

**Solution Manual for Digital Systems Design Using VHDL 3rd Edition by Roth John
ISBN 1305635140 9781305635142**

Full link download:

Solution Manual:

<https://testbankpack.com/p/solution-manual-for-digital-systems-design-using-vhdl-3rd-edition-by-roth-john-isbn-1305635140-9781305635142/>

Chapter 2 Solutions

- 2.1 (a) VHDL - VHSIC Hardware Description Language
VHSIC - Very High Speed Integrated Circuit
- (b) VHDL has statements that execute concurrently since it must model real hardware in which the components are all in operation at the same time.
- (c) A hardware description language allows a digital system to be designed and debugged at a higher level of abstraction than schematic capture with gates, flip-flops, and standard MSI building blocks. The details of the gates and flip-flops do not need to be handled during early phases of design. Designs are more portable when low-level library-specific details are not included in the model. HDLs allow the creation of such portable high-level behavioral models.

- 2.2 (a) Legal: A_123, and1; Illegal: 123A (Starts with number), _A123 (starts with underscore), A123_ (ends with underscore), c1 c2 (adjacent underscores), and (reserved word).
- (b) They all equivalent. VHDL is not case sensitive.

- 2.3 (a)

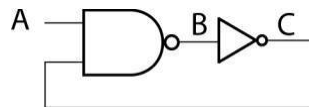

- (b)

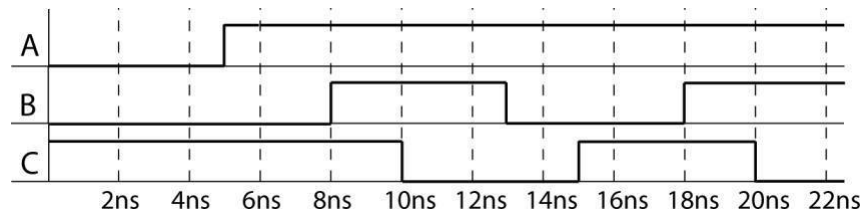

```
2.4 entity Comb is
  port(A, B, C, D : in bit;
        Z : out bit);
end Comb;
architecture Comb2_1 of Comb is
  signal E, F, G, H, I : bit;
begin
  H<=(A and B and C) after 5 ns;
  E<=H or D after 5 ns;
  G<=(B nor C) after 5 ns;
  F<=G nand A after 5 ns;
  I <= not F after 2 ns;
  Z<=E xor I after 5 ns;
end Comb2_1;
```

- 2.5 (a) entity one_bit_sub is
port(x, y, bin: in bit;
diff, bout: out bit);

```
end one_bit_sub;
architecture equ of one_bit_sub is
begin
    diff <= x xor y xor bin; -- difference. See problem 1.2 answer

    bout <= (not x and bin) or (not x and y)
            or (bin and y); -- borrow out. See problem 1.2 answer
```

```
end equ;
```

```
(b) entity four_bit_sub is
    port(a, b: in bit_vector(3 downto 0);
          bin: in bit;
          d: out bit_vector(3 downto 0);
          bout: out bit);
end four_bit_sub;

architecture test of four_bit_sub is
    signal bo: bit_vector(3 downto 0) := "0000"; -- borrow bits
    component one_bit_sub
        port(x, y, bin: in bit;
             diff, bout: out bit);
    end component;
begin
    FS0: one_bit_sub port map(a(0),b(0),bin,d(0),bo(1));
    FS1: one_bit_sub port map(a(1),b(1),bo(1),d(1),bo(2));
    FS2: one_bit_sub port map(a(2),b(2),bo(2),d(2),bo(3));
    FS3: one_bit_sub port map(a(3),b(3),bo(3),d(3),bout);
end test;
```

```
2.6 (a) entity circuit is
    port(A, B, C, D: in bit;
          G: out bit);
end circuit;

architecture internal of circuit is
    signal E, F: bit;
begin
    E <= A and B;
    F <= E or C;
    G <= D and F;
end internal;
```

```
(b) entity circuit is
    port(A, B, C, D: in bit;
          G: out bit);
end circuit;

architecture internal of circuit is
    signal E, F: bit;
begin
    process(A, B, C, D, E, F)
    begin
        E <= A and B;
        F <= E or C;
        G <= D and F;
    end process;
end internal;
```

2.7 A changes to 1 at 25 ns, B changes to 1 at $20 + \Delta$ ns, C does not change

2.8 (a) A falling-edge triggered D flip-flop with asynchronous active high clear and set

(b) Q = '0', because Clr = 1 has priority.

```
2.9 entity SR_Latch is
    port(S, R: in bit;
          Q, Qn: inout bit);
end SR_Latch;
```

```

architecture proc of SR_Latch is
begin
  process(S, R)
  begin
    if S = '1' then Q <= '1'; end if;
    if R = '1' then Q <= '0'; end if;
  end process;
  Qn <= not Q;
end proc;

```

2.10 entity MNFF is
 port(M, N, CLK, CLRn: in bit; Q: inout bit; Qn: out bit);
 end MNFF;

```

architecture MN of MNFF is
begin
  process(CLK, CLRn)
  begin
    if CLRn = '0' then Q <= '0';
    elsif CLK = '0' and CLK'event then
      if M = '0' and N = '0' then Q <= not Q;
      elsif M = '0' and N = '1' then Q <= '1';
      elsif M = '1' and N = '0' then Q <= '0';
      elsif M = '1' and N = '1' then Q <= Q; --
      optional end if;
    end if;
  end process;
  QN <= not Q;
end MN;

```

2.11 entity DDFD is
 port(R, S, D, Clk : in bit;
 Q : out bit);
 end DDFD;

```

architecture Behav of DDFD is
begin
  process(Clk, R, S)
  begin
    if R = '0' then Q <= '0';
    elsif S = '0' then Q <= '1';
    elsif Clk'event then Q <= D;
    end if;
  end process;
end Behav;

```

2.12 (a) entity ITFF is
 port(I0, I1, T, R: in bit;
 Q, QN: inout bit);
 end ITFF;

```

architecture behavior of ITFF is
begin
  process(T, R)
  begin
    if R = '1' then
      Q <= '0' after 5 ns;
    else
      if (I0 = '1' and T = '1' and T'event) or
      (I1 = '1' and T = '0' and T'event) then
        Q <= QN after 8 ns;
      end if;
    end if;
  end process;
end behavior;

```

```

end if;
end process;
QN <= not Q;
end behavior;

```

```

(b) add list *
add wave *
force T 0 0, 1 100 -repeat
200 force I1 0 0, 1 50, 0 450
force I0 0 0, 1 450
run 750 ns

```

2.13

ns	Δ	a	b	c	d	e	f
0	+0	0	0	0	0	0	0
5	+0	0	0	0	1	0	0
5	+1	1	0	0	1	0	0
5	+2	1	1	1	1	0	0
5	+3	1	1	1	0	0	0
10	+0	1	1	1	0	1	0
10	+1	0	1	1	0	1	0
10	+2	0	0	0	0	1	0

2.14

ns	Δ	a	b	c	d	e	f
0	+0	0	0	0	0	0	0
5	+0	0	0	0	1	0	0
5	+1	1	0	0	1	0	0
5	+2	1	1	1	1	0	0
5	+3	1	1	1	0	0	0
10	+0	1	1	1	0	1	0
10	+1	0	1	1	0	1	0
10	+2	0	0	0	0	1	0

2.15

ns	Δ	a	b	c	d	e	f
0	+0	0	0	0	0	0	0
5	+0	0	0	0	1	0	0
5	+1	1	0	0	1	0	0
5	+2	1	1	1	1	0	0
5	+3	1	1	1	0	0	0
10	+0	1	1	1	0	1	0
10	+1	0	1	1	0	1	0
10	+2	0	0	0	0	1	0

2.16

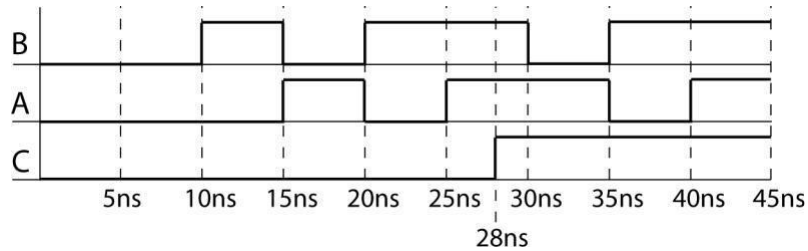

2.17

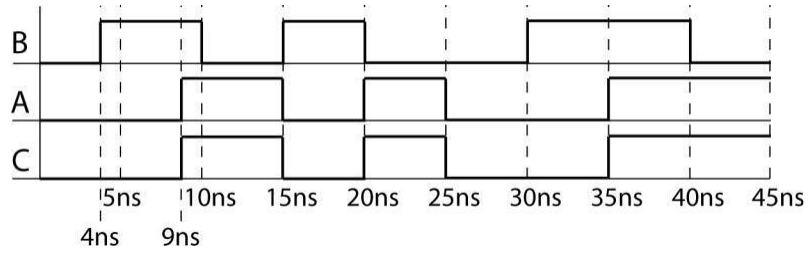

2.18

ns	Δ	a	b	c	d	
4	+0	0	0	0	0	
5	+0	1	0	0	0	P1 executes
10	+0	1	1	0	0	P2 executes
10	+1	0	1	0	1	P1 executes
12	+0	0	1	1	1	
15	+0	0	0	1	1	P2 executes
15	+1	1	0	1	1	P1 executes
17	+0	1	0	0	1	

2.19 (a) $101011 \text{ or } 011010 = 111011$

(b) $101 \text{ ror } 2 = 011$

(c) $101 \text{ sla } 2 = 111$

(d) $101 \& \text{not } 011 = 101 \& 100 = 101100$

$101100 \neq 111110$, so evaluates to false

(e) $101 \text{ or } 011 \text{ and } 010 = 111 \text{ and } 010 = 010$

2.20 (a)

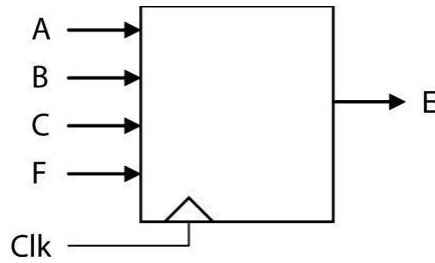

(b)

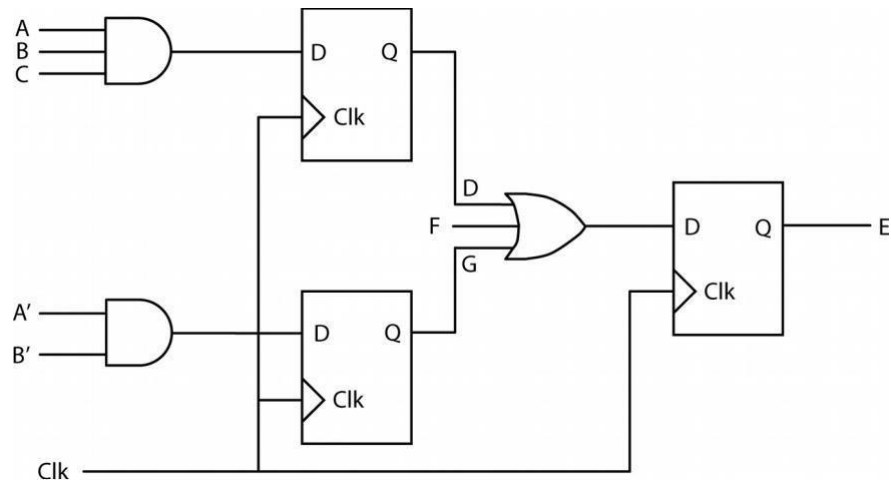

2.21

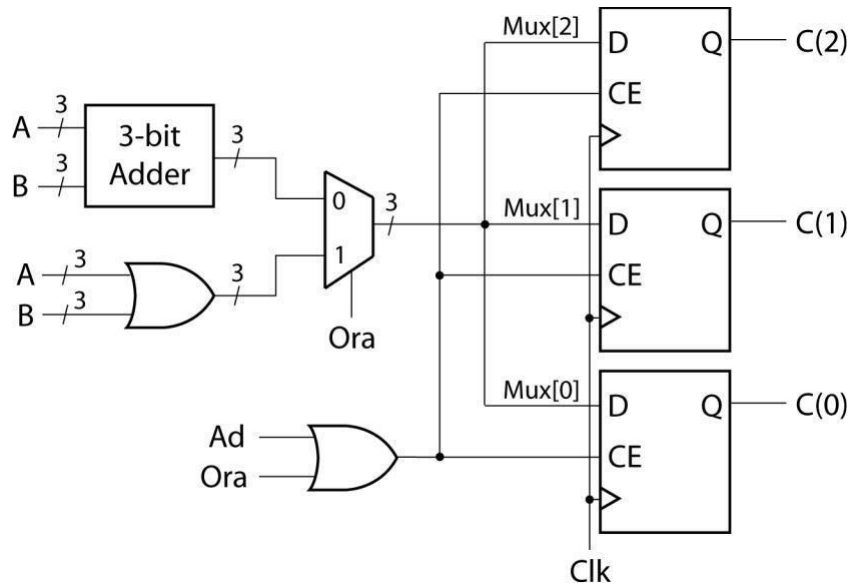

2.22

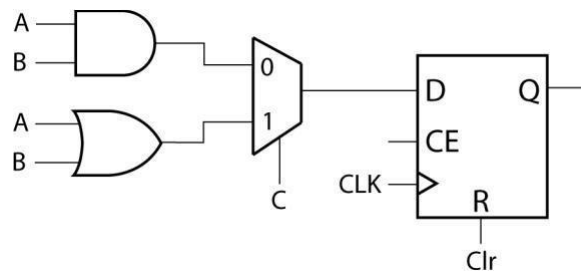

Unlike *Clr*, the output from the mux is only read on falling clock edges; therefore, adding *C* to the sensitivity list is not required for proper operation of the circuit.

- 2.23 (a)

```
sel <= C&D;
with sel select
  F <= not A after 10 ns when "00",
    B after 10 ns when "01",
    not B after 10 ns when "10",
    '0' after 10 ns when "11";
```
- (b)

```
F <= not A after 10 ns when C&D = "00"
    else B after 10 ns when C&D = "01"
    else not B after 10 ns when C&D =
    "10" else '0' after 10 ns;
```
- (c)

```
sel <= C&D;
process(sel)
begin
  case sel is
    when "00" => F <= not A after 10 ns;
    when "01" => F <= B after 10 ns; when
    "10" => F <= not B after 10 ns; when
    "11" => F <= '0' after 10 ns;
  end case;
end process;
```

```

2.24 (a) process (C, B1, B2, B3)
begin
  case C is
    when 1 => A <= B1;
    when 2 => A <= B2;
    when 3 => A <= B3;
    when others => A <= 0;
  end case;
end process;

```

or

```

process (C, B1, B2, B3)
begin
  if C = 1 then A <= B1;
  elsif C = 2 then A <= B2;
  elsif C = 3 then A <= B3;
  else A <= 0; end if;
end process;

```

(b)

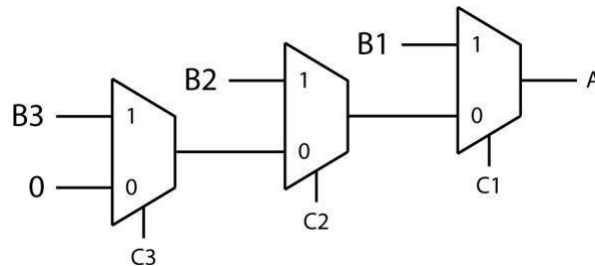

```

2.25 (a) entity Latch is
  port(S, R: in bit;
        P, Q: inout bit);
end Latch;

architecture conditional of Latch is
begin
  Q <= '1' when S = '1' -- Assume SR = 0
  else '0' when R = '1'
  else Q;
P
  <= not Q;
end conditional;

```

```

(b) architecture characteristic of Latch is
begin
  Q <= S or (not R and Q);
  P <= not Q;
end characteristic;

```

```

(c) architecture gate of Latch is
begin
  P <= S nor Q;
  Q <= R nor P;
end gate;

```

2.26 $S = "0101"$, $Co = '1'$

```

2.27 library IEEE;
    use IEEE.numeric_bit.all;

    entity Adder is
        port(A: in bit_vector(3 downto 0);
             B: in integer range 0 to 15;
             Sum: out bit_vector(4 downto 0));
    end Adder;

    architecture overloaded of Adder is
        signal sum5: unsigned(4 downto 0);
    begin
        sum5 <= '0' & UNSIGNED(A) + TO_UNSIGNED(B, 4); -- conv fns in Appndx
        B_Sum <= BIT_VECTOR(sum5);
    end overloaded;

```

2.28

```

(a) entity decoder_3to8_behavioral is port(A0,
    A1, A2, E1_bar, E2_bar, E3: in bit;
    Y0_bar, Y1_bar, Y2_bar, Y3_bar, Y4_bar, Y5_bar, Y6_bar, Y7_bar: out bit := '1'); end
decoder_3to8_behavioral;

```

architecture behavior of decoder_3to8_behavioral is

```

signal input_values:bit_vector(3 downto 0);

```

```

signal enable:bit;

```

```

begin

```

```

    enable<=E3 and (not E2_bar) and (not E1_bar);

```

```

    input_values<=(enable)&(A2)&(A1)&(A0);

```

```

    process (input_values) begin

```

```

        case input_values is

```

```

            when "1000" =>

```

```

                Y0_bar <='0';

```

```

                Y1_bar <='1';

```

```

                Y2_bar <='1';

```

```

                Y3_bar <='1';

```

```

                Y4_bar <='1';

```

```

                Y5_bar <='1';

```

```

                Y6_bar <='1';

```

```

                Y7_bar <='1';

```

```

            when "1001" =>

```

```

                Y0_bar <='1';

```

```

                Y1_bar <='0';

```

```

                Y2_bar <='1';

```

```

                Y3_bar <='1';

```

```

                Y4_bar <='1';

```

```

                Y5_bar <='1';

```

```

                Y6_bar <='1';

```

```

                Y7_bar <='1';

```

```

            when "1010" =>

```

```

                Y0_bar <='1';

```

```

                Y1_bar <='1';

```

```

                Y2_bar <='0';

```

```

                Y3_bar <='1';

```

```

                Y4_bar <='1';

```

```

                Y5_bar <='1';

```

```

                Y6_bar <='1';

```

```

                Y7_bar <='1';

```

```
when "1011" =>
  Y0_bar <='1';
  Y1_bar <='1';
  Y2_bar <='1';
  Y3_bar <='0';
  Y4_bar <='1';
  Y5_bar <='1';
  Y6_bar <='1';
  Y7_bar <='1';
when "1100" =>
  Y0_bar <='1';
  Y1_bar <='1';
  Y2_bar <='1';
  Y3_bar <='1';
  Y4_bar <='0';
  Y5_bar <='1';
  Y6_bar <='1';
  Y7_bar <='1';
when "1101" =>
  Y0_bar <='1';
  Y1_bar <='1';
  Y2_bar <='1';
  Y3_bar <='1';
  Y4_bar <='1';
  Y5_bar <='0';
  Y6_bar <='1';
  Y7_bar <='1';
when "1110" =>
  Y0_bar <='1';
  Y1_bar <='1';
  Y2_bar <='1';
  Y3_bar <='1';
  Y4_bar <='1';
  Y5_bar <='1';
  Y6_bar <='0';
  Y7_bar <='1';
when "1111" =>
  Y0_bar <='1';
  Y1_bar <='1';
  Y2_bar <='1';
  Y3_bar <='1';
  Y4_bar <='1';
  Y5_bar <='1';
  Y6_bar <='1';
  Y7_bar <='0';
when others
=>   Y0_bar
<='1';
  Y1_bar <='1';
  Y2_bar <='1';
  Y3_bar <='1';
  Y4_bar <='1';
  Y5_bar <='1';
  Y6_bar <='1';
  Y7_bar <='1';
end case;
end process;
```

end behavior;

```
(b) entity decoder_3to8_dataflow is port(A0,
    A1, A2, E1_bar, E2_bar, E3: in bit;
    Y0_bar, Y1_bar, Y2_bar, Y3_bar, Y4_bar, Y5_bar, Y6_bar, Y7_bar: out bit := '1');
end decoder_3to8_dataflow;
```

architecture dataflow of decoder_3to8_dataflow is

```
signal enable:bit;
begin
    enable<=(E3) and (not E2_bar) and (not E1_bar);
    Y0_bar<=not((enable)and(not A2)and(not A1)and(not A0));
    Y1_bar<=not((enable)and(not A2)and(not A1)and(A0));
    Y2_bar<=not((enable)and(not A2)and(A1)and(not A0));
    Y3_bar<=not((enable)and(not A2)and(A1)and(A0));
    Y4_bar<=not((enable)and(A2)and(not A1)and(not A0));
    Y5_bar<=not((enable)and(A2)and(not A1)and(A0));
    Y6_bar<=not((enable)and(A2)and(A1)and(not A0));
    Y7_bar<=not((enable)and(A2)and(A1)and(A0));
```

end dataflow;

```
(c) entity decoder_3to8_structural is port(A0,
    A1, A2, E1_bar, E2_bar, E3: in bit;
    Y0_bar, Y1_bar, Y2_bar, Y3_bar, Y4_bar, Y5_bar, Y6_bar, Y7_bar: out bit := '1');
end decoder_3to8_structural;
```

architecture structure of decoder_3to8_structural is

```
component inverter
    port(A: in bit; Z: out bit);
end component;
```

```
component and3
    port(A, B, C: in bit; Z: out bit);
end component;
```

```
component and4
    port(A, B, C, D: in bit; Z: out bit);
end component;
```

```
signal A2prime, A1prime, A0prime, invertA2prime, invertA1prime, invertA0prime, E1, E2, Y0, Y1,
    Y2, Y3, Y4, Y5, Y6, Y7, enable: bit;
```

```
begin
    I0:inverter port map(A2, A2prime);
    I1:inverter port map(A1, A1prime);
    I2:inverter port map(A0, A0prime);
    I3:inverter port map(E1_bar, E1);
    I4:inverter port map(E2_bar, E2);
    I5:inverter port map(A2prime, invertA2prime);
    I6:inverter port map(A1prime, invertA1prime);
    I7:inverter port map(A0prime, invertA0prime);
    I8:inverter port map(Y0, Y0_bar);
    I9:inverter port map(Y1, Y1_bar);
    I10:inverter port map(Y2, Y2_bar);
    I11:inverter port map(Y3, Y3_bar);
```

```

I12:inverter port map(Y4,Y4_bar);
I13:inverter port map(Y5,Y5_bar);
I14:inverter port map(Y6,Y6_bar);
I15:inverter port map(Y7,Y7_bar);
AG0:and4 port map(enable,A2prime,A1prime,A0prime,Y0);
AG1:and4 port map(enable,A2prime,A1prime,invertA0prime,Y1);
AG2:and4 port map(enable,A2prime,invertA1prime,A0prime,Y2);
AG3:and4 port map(enable,A2prime,invertA1prime,invertA0prime,Y3);
AG4:and4 port map(enable,invertA2prime,A1prime,A0prime,Y4);
AG5:and4 port map(enable,invertA2prime,A1prime,invertA0prime,Y5);
AG6:and4 port map(enable,invertA2prime,invertA1prime,A0prime,Y6);
AG7:and4 port map(enable,invertA2prime,invertA1prime,invertA0prime,Y7);
AG8:and3 port map(E1,E2,E3, enable);

```

```
end structure;
```

```

entity inverter is
port(A: in bit; Z: out bit);
end inverter;
architecture inv of inverter is
begin
Z <= not A;
end inv;

```

```

entity and3 is
port(A, B, C: in bit; Z: out bit);
end and3;
architecture concur of and3 is
begin
Z <= (A and B and C);
end concur;

```

```

entity and4 is
port(A, B, C, D: in bit; Z: out bit);
end and4;
architecture con of and4 is
begin
Z <= (A and B and C and D);
end con;

```

2.29

```

entity decoder_4to16_structural is
port(A0, A1, A2, A3, E1_bar, E2_bar, E3: in bit;
      Y0_bar, Y1_bar, Y2_bar, Y3_bar, Y4_bar, Y5_bar, Y6_bar, Y7_bar, Y8_bar, Y9_bar, Y10_bar, Y11_bar,
      Y12_bar, Y13_bar, Y14_bar, Y15_bar: out bit := '1');
end decoder_4to16_structural;

```

```

architecture decoder of decoder_4to16_structural is
component decoder_3to8_structural
port(A0, A1, A2, E1_bar, E2_bar, E3: in bit; Y0_bar, Y1_bar, Y2_bar, Y3_bar, Y4_bar, Y5_bar, Y6_bar,
      Y7_bar: out bit);
end component;

```

```

signal A2prime, A1prime, A0prime, invertA2prime, invertA1prime, invertA0prime, E1, E2, Y0, Y1,
      Y2, Y3, Y4, Y5, Y6, Y7, enable: bit;

```

```

begin
  D1:decoder_3to8_structural port map(A0, A1, A2, A3, E2_bar, E3, Y0_bar, Y1_bar, Y2_bar, Y3_bar,
    Y4_bar, Y5_bar, Y6_bar, Y7_bar);
  D2:decoder_3to8_structural port map(A0, A1, A2, E1_bar, E2_bar, A3, Y8_bar, Y9_bar, Y10_bar,
    Y11_bar, Y12_bar, Y13_bar, Y14_bar, Y15_bar);
end decoder;

```

2.30

(a) entity alu is

```

port(M,Cn:in bit;

      F: out bit_vector(3 downto 0);
      S: in bit_vector(3 downto 0));
end alu;

```

architecture unit of alu is

```

begin
  process(A,B,S,M,Cn) begin
    case S is
      when "0000"=>F<=not A;
      when "0001"=>F<=not(A and B);
      when "0010"=>F<=(not A) and B;
      when "0011"=>F<="0001";
      when "0100"=>F<=not (A or B);
      when "0101"=>F<=not B;
      when "0110"=>F<=not(A XOR B);
      when "0111"=>F<=A or (not B);
      when "1000"=>F<=(not A) and B;
      when "1001"=>F<=A XOR B;
      when "1010"=>F<=B;
      when "1011"=>F<=A or B;
      when "1100"=>F<="0000";
      when "1101"=>F<=A and (not B);
      when "1110"=>F<=A and B;
      when "1111"=>F<=A;
    end case;
  end process;

```

end unit;

(b) library IEEE;

use IEEE.numeric_bit.all;

entity alu is

```

port(M,Cn:in bit;
      A,B: in unsigned (3 downto 0);
      F:out unsigned (3 downto 0);
      S: in bit_vector(3 downto
0)); end alu;

```

architecture arithunit of alu is

```

begin
  process(A,B,S,M,Cn) begin

```

```

if(Cn='0') then
  case S is
    when "0000"=>F<=A-1;
    when "0001"=>F<=(A and B) - 1;
    when "0010"=>F<=(A and (not B)) -1;
    when "0011"=>F<="1111";
    when "0100"=>F<= A+(A or (not B));
    when "0101"=>F<= (A and B) + (A or (not B));
    when "0110"=>F<= A - B - 1;
    when "0111"=>F<= A or (not B);
    when "1000"=>F<= A + (A or B);
    when "1001"=>F<=A + B;
    when "1010"=>F<= (A and (not B))+(A or B);
    when "1011"=>F<=A or B;
    when "1100"=>F<=A + (A sll 1);
    when "1101"=>F<= (A and B) + A;
    when "1110"=>F<= (A and (not B)) + A;
    when "1111"=>F<=A;
  end case;
else
  case S is
    when "0000"=>F<=A;
    when "0001"=>F<=(A and B);
    when "0010"=>F<=(A and (not B));
    when "0011"=>F<="0000";
    when "0100"=>F<= A+(A or (not B))+1;
    when "0101"=>F<= (A and B) + (A or (not B)) + 1;
    when "0110"=>F<= A - B;
    when "0111"=>F<= A or (not B) + 1;
    when "1000"=>F<= A + (A or B) + 1;
    when "1001"=>F<=A + B + 1;
    when "1010"=>F<= (A and (not B))+(A or B) + 1;
    when "1011"=>F<=(A or B) +1;
    when "1100"=>F<=A + A + 1;
    when "1101"=>F<= (A and B) + A + 1;
    when "1110"=>F<= (A and (not B)) + A + 1;
    when "1111"=>F<=A + 1;
  end case;
end if;
end process;

```

end arithunit;

2.31 (a) library IEEE;

```

  use IEEE.numeric_bit.all;

  entity counter is
    port(d: in unsigned(3 downto 0);
         clk, clr, ent, enp, up, load: in bit;
         q: inout unsigned(3 downto 0); co: out bit);
  end counter;

  architecture test of counter is
  begin
    process(clk, clr)
    begin

```

```

if clr = '0' then Q <= "0000";
elsif clk = '1' and clk'event then

    if load = '0' then q <= d; -- load
    elsif (ent = '1' and enp = '1' and (not up) = '1') then
        if q = "0000" then q <= "1001"; -- wrap around
        else q <= q - 1; end if; --decrement
    elsif (ent = '1' and enp = '1' and up = '1') then
        if q = "1001" then q <= "0000"; -- wrap around
        else q <= q + 1; end if; --increment
    end if;
end if;
end process;

co <= '1' when (ent = '1') and ((up = '1' and (Q = "1001")) or
    (up = '0' and (Q ="0000"))) else '0';

end test;

```

(b) The block diagram is similar to Figure 2-47 with an "Up" input added to each counter. The VHDL description similar to Figure 2-48.

- 2.32** Students should look on the web for 74192 data sheet. CLR is active high. LOADB is active low. Counting up happens when UP has a rising edge and DOWN=1. Counting down happens when DOWN has a rising edge and UP=1. CARRY indicates terminal count in the up direction, i.e. 9. BORROW indicates terminal count in the down direction, i.e. 0.

Operating Mode	CLR	LOADB	UP	DOWN	D	Q	Borrow	Carry
Clear	1	X	X	0	XXXX	0000	0	1
	1	X	X	1	XXXX	0000	1	1
Load	0	0	X	X	XXXX	Q = D	1*	1*
Count Up	0	1	↑	1	XXXX	Q=Q+1	1	1**
Count Down	0	1	1	↑	XXXX	Q=Q-1	1**	1

* when loading, if the input is 0 and down = 0, borrow will be 0. If the input is 9 and up = 0, carry will be 0

** Borrow = 0 when the counter is in state 0 and down = 0. Carry = 0 when the counter is in state 9 and up = 0.

```

entity count74192 is
    port(DOWN, UP, CLR, LOADB: in bit;
        BORROW, CARRY: out bit;
        D: in integer range 0 to 15;
        Q: inout integer range 0 to 15);
end count74192;

architecture behav of count74192 is
begin
    process(DOWN, UP, CLR, LOADB)
    begin
        if CLR = '1' then Q <= 0;
        elsif LOADB = '0' then Q <= D;
        elsif UP'event and UP = '1' and DOWN = '1'
            then if Q = 9 then Q <= 0;
                else Q <= Q + 1; end if;
            elsif DOWN'event and DOWN = '1' and UP = '1' then
                if Q = 0 then Q <= 9;
                    else Q <= Q - 1; end if;
            end if;
        end process;

        -- borrow rises on rising edge of DOWN in state 0
        BORROW <= '0' when DOWN = '0' and Q = 0 else '1';

```

```

-- carry rises on rising edge of UP in state 9
CARRY <= '0' when UP = '0' and Q = 9 else '1';
end behave;

```

2.33 (a) entity shift8 is

```

port(Q: inout bit_vector(7 downto 0);
     D: in bit_vector(7 downto 0);
     CLR, CLK, S0, S1, LSI, RSI: in bit);
end shift8;

```

(b) architecture behave of shift8 is

```

begin
  process(CLK, CLR)
  begin
    if CLR = '1' then Q <= "00000000";
    elsif (CLK = '1' and CLK'event) then
      if (S0 = '1' and S1 = '1') then Q <=
        D; elsif (S0 = '0' and S1 = '1') then
        Q <= RSI & Q(7 downto 1); elsif
        (S0 = '1' and S1 = '0') then
        Q <= Q(6 downto 0) &
        LSI; end if;
      end if;
    end process;
  end behave;

```

(c)

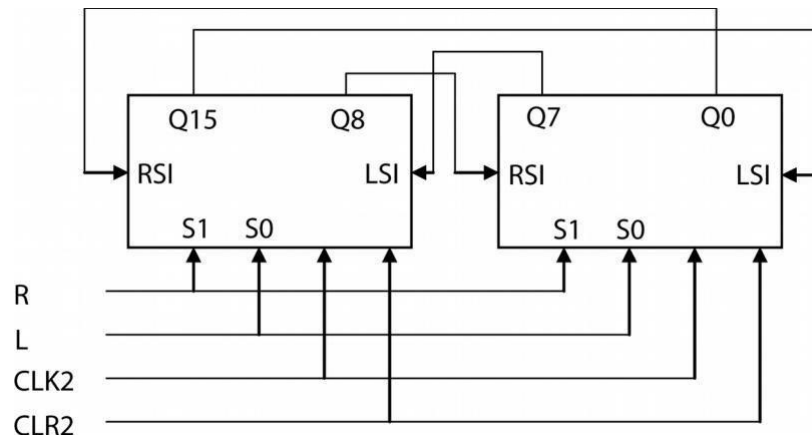

(d) entity shiftreg is

```

port(QQ: inout bit_vector(15 downto 0);
     DD: in bit_vector(15 downto 0);
     CLK2, CLR2, L, R: in bit);
end shiftreg;

```

(e) architecture struct of shiftreg is

```

component shift8 is
  port(Q: inout bit_vector(7 downto 0);
       D: in bit_vector(7 downto 0);
       CLR, CLK, S0, S1, LSI, RSI: in bit);
end component;
begin
  SR1: shift8 port map(QQ(15 downto 8), DD(15 downto 8),
    CLR2, CLK2, L, R, QQ(7), QQ(0));
  SR2: shift8 port map(QQ(7 downto 0), DD(7 downto 0),
    CLR2, CLK2, L, R, QQ(15), QQ(8));
end struct;

```



```

2.34 library IEEE;
use IEEE.numeric_bit.all;

entity countQ1 is
  port (clk, Ld8, Enable: in bit; S5: out bit;
        Q: out unsigned(3 downto 0));
end countQ1;

architecture counter of countQ1 is
  signal Qint: unsigned(3 downto 0);
begin
  process (clk)
  begin
    if clk'event and clk = '1' then
      if Ld8 = '1' then Qint <= "1000";
      elsif Enable = '1' then
        if Qint = "0011" then Qint <= "1000";
        else Qint <= Qint - 1; end if;
      end if;
    end if;
  end process;
  S5 <= '1' when Qint <= "0101" else '0';
  Q <= Qint;
end counter;

```

```

2.35 (a) library IEEE;
use IEEE.numeric_bit.all;

entity up_down is
  port (CLK, CLR, LD, UP: in bit; D: in unsigned(3 downto 0);
        Q: inout unsigned(3 downto 0));
end up_down;

architecture counter of up_down is
begin
  process
  begin
    wait until CLK = '0' and CLK'event;
    if CLR = '1' then Q <= "0000";
    elsif LD = '1' then Q <= D;
    elsif UP = '1' then Q <= Q + 1;
    else Q <= Q - 1;
    end if;
  end process;
end counter;

```

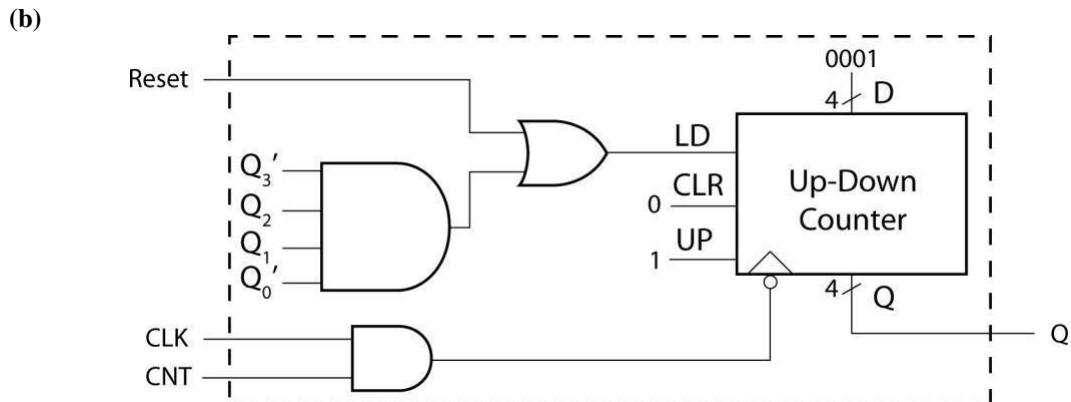

```

(c) library IEEE;
    use IEEE.numeric_bit.all;

    entity modulo6 is
        port(Q: inout unsigned(3 downto 0);
             CLK, Reset, CNT: in bit);
    end entity;

    architecture six of modulo6 is
        component up_down is
            port(CLK, CLR, LD, UP: in bit;
                 D: in unsigned(3 downto 0);
                 Q: inout unsigned(3 downto 0));
        end component;
        signal load, clock: bit;
    begin
        load <= Reset or (not Q(0) and Q(1) and Q(2) and not Q(3));
        clock <= CLK and CNT; --assume CNT changes when CLK is 0
        U0: up_down port map(CLOCK, '0', load, '1', "0001", Q);
    end six;

```

2.36 (a)

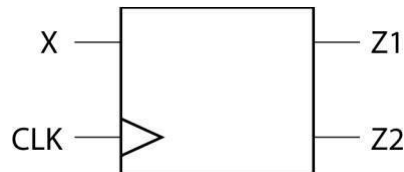

(b)

Present State	Next State		X = 0		X = 1	
	X = 0	X = 1	Z1	Z2	Z1	Z2
S0	S0	S1	1	0	0	0
S1	S1	S2	0	1	0	1
S2	S2	S3	0	1	0	1
S3	S0	S1	0	0	1	0

2.37 The following solutions utilize the solution for 1.13.

```

(a) entity P2_37 is
    port(X, CLK: in bit;
         S, V: out bit);

    end P2_37;

    architecture Table of P2_37 is
        type StateTable is array
            (integer range <>, bitrange <>) of integer;
        type OutTable is array
            (integer range <>, bitrange <>) of bit_vector(1 downto 0);
        signal State, NextState: integer := 0;
        signal SV: bit_vector(1 downto 0);
        constant ST: StateTable (0 to 5, '0' to '1') :=

            ((1,1), (2,4), (3,3), (0,0), (3,5), (0,0));
        constant OT: OutTable (0 to 5, '0' to '1') :=
            (("00", "10"), ("10", "00"), ("00", "10"), ("00", "10"),
            ("10", "00"), ("10", "01"));
    begin
        NextState <= ST(State, X);

        SV <= OT(State, X);
        S <= SV(1); -- Alternate method S <= OT(State,X)(1)
        V <= SV(0); -- V <= OT(State,X)(0)

        process (CLK)

```

```

begin
    if CLK'event and CLK = '0' then
        State <= NextState;
    end if;
end process;

end Table;

(b) entity P2_37 is
    port(X, CLK: in bit;
         S, V: out bit);

end P2_37;

architecture Equations of P2_37 is
    signal Q1, Q2, Q3: bit;
begin
    process(CLK)
    begin
        if CLK = '0' and CLK'event then

            Q1 <=not Q1 and Q3;
            Q2 <= (not Q2 and not Q3) or (X and not Q1 and Q2);

            Q3 <= (not Q1 and Q3) or (Q2 and not Q3);
        end if;
    end process;
    S<=(X and not Q2) or (not X and Q2);

    V<=(X and Q1 and Q2);

end Equations;

(c) entity P2_37 is
    port(X, CLK: in bit;
         S, V: out bit);

end P2_37;

architecture Structural of P2_37 is
    component DFF
        port(D, CLK: in bit; Q: out bit; QN: out bit := '1');
    end component;
    component And2
        port(A1, A2: in bit; Z: out bit);
    end component;
    component Or2
        port(A1, A2: in bit; Z: out bit);
    end component;
    component And3
        port(A1, A2, A3: in bit; Z: out bit);
    end component;
    component Inverter
        port(A: in bit; Z: out bit);
    end component;
    signal Q1, Q2, Q3: bit := '0';
    signal XN, Q1N, Q2N, Q3N: bit := '1';
    signal D1, D2, D3: bit := '0';
    signal A1, A2, A3, A4, A5, A6: bit := '0';
begin
    I1: Inverter port map (X, XN);
    G1: And2 port map (Q1N, Q3, D1);
    G2: And2 port map (Q2N, Q3N, A1);
    G3: And3 port map (X, Q1N, Q2, A2);
    G4: Or2 port map (A1, A2, D2);
    G5: And2 port map (Q1N, Q3, A3);
    G6: And2 port map (Q2, Q3N, A4);
    G7: Or2 port map (A3, A4, D3);

    G8: And2 port map (X, Q2N, A5);

```

```

G9: And2 port map (XN, Q2, A6);
G10: Or2 port map (A5, A6, S);
G11: And3 port map (X, Q1, Q2, V);
DFF1: DFF port map (D1, CLK, Q1, Q1N);
DFF2: DFF port map (D2, CLK, Q2, Q2N);
DFF3: DFF port map (D3, CLK, Q3, Q3N);
end Structural;

```

See Section 2.15 for the definition of the DFF component. The And3, And2, Or2, and Inverter components are all similar to the Nand3 component given on pages 109-110 (section 2.15).

2.38 The following solutions utilize the solution for 1.14.

```

(a) entity P2_38a is
    port(X, CLK: in bit;
         D, B: out bit);
end P2_38a;

architecture Table of P2_38a is
    signal State, NextState: integer range 0 to
5; begin
    process(State, X)
    begin
        case State is
            when 0 => if X = '0' then D <= '0'; B <= '0'; NextState <= 1;
                else D <= '1'; B <= '0'; NextState <= 1; end if;
            when 1 => if X = '0' then D <= '1'; B <= '0'; NextState <= 2;
                else D <= '0'; B <= '0'; NextState <= 3; end if;
            when 2 => if X = '0' then D <= '1'; B <= '0'; NextState <= 4;
                else D <= '0'; B <= '0'; NextState <= 5; end if;
            when 3 => if X = '0' then D <= '0'; B <= '0'; NextState <= 5;
                else D <= '1'; B <= '0'; NextState <= 5; end if;
            when 4 => if X = '0' then D <= '1'; B <= '1'; NextState <= 0;
                else D <= '0'; B <= '0'; NextState <= 0; end if;
            when 5 => if X = '0' then D <= '0'; B <= '0'; NextState <= 0;
                else D <= '1'; B <= '0'; NextState <= 0; end if;
        end case;
    end process;
    process(CLK)
    begin
        if (CLK = '0' and CLK'event) then
            State <= NextState; end if;
        end process;
end Table;

```

```

(b) entity P2_38b is
    port(X, CLK: in bit;
         D, B: out bit);
end P2_38b;

architecture Equations of P2_38b is
    signal Q1, Q2, Q3: bit;
begin
    process(CLK)
    begin
        if (CLK='0' and CLK'event) then
            Q1 <= (not Q1 and not Q3) or (not X and Q1 and not Q2);
            Q2 <= (not Q2 and Q3);
            Q3 <= not Q2 and (Q3 or Q1);
        end if;
    end process;
    D <= (not X and Q1) or (X and not Q1 and
Q3); B <= not X and Q1 and Q2;

```



```

        when others => null;
    end case;
end if;
end process;
end moore_mach_bhv;

```

2.40 entity P_40 is

```

    port(x1, x2, clk: in bit;
         z1, z2: out bit);
end P_40;

```

architecture behavioral of P_40 is

```

    signal state, next_state: integer range 1 to 3;
begin
    process(state, x1, x2)
    begin
        case state is
            when 1 => if ((x1 & x2) = "00") then next_state <= 3 after 10 ns;
                    elsif ((x1&x2) = "01") then next_state <= 2 after 10
                    ns; else next_state <= 1 after 10 ns; end if;
            when 2 => if ((x1 & x2) = "00") then next_state <= 2 after 10 ns;
                    elsif ((x1&x2) = "01") then next_state <= 1 after 10
                    ns; else next_state <= 3 after 10 ns; end if;
            when 3 => if ((x1 & x2) = "00") then next_state <= 1 after 10 ns;
                    elsif ((x1&x2) = "01") then next_state <= 2 after 10
                    ns; else next_state <= 3 after 10 ns; end if;

        end case;
    end process;
    process(clk)
    begin
        if (clk = '0' and clk'event) then
            state <= next_state after 5 ns; end if;
        end process;
        z1 <= '1' after 10 ns when state = 2 else '0' after 10 ns;
        z2 <= '1' after 10 ns when state = 3 else '0' after 10 ns;
    end behavioral;

```

2.41 (a) *nextstate* is not always assigned a new value in the conditional statements, else clauses are not specified. so a latch will be created to hold *nextstate* to its old value.

(b) The latch output would have the most recent value of *nextstate*.

(c) process(state, X)

```

begin
    case state is
        when 0 => if X = '1' then nextstate <= 1;
                else nextstate <= 0; end if;
        when 1 => if X = '0' then nextstate <= 2;
                else nextstate <= 1; end if;
        when 2 => if X = '1' then nextstate <= 0;
                else nextstate <= 2; end if;

    end case;
end process;

```

2.42

Signal or Variable	time	new value
A	20 ns	1
F	20 ns	6
A	20 ns	6
B	25 ns	7
C	30 ns	2
D	35 ns	5

Note: The change to A=1 is never visible.

2.43 *Sel* should be a variable, instead of a signal. Otherwise *sel* will not update for current use. It updates only at the end of a process so the case statement will get the wrong value.

2.44

ns	Δ	A	B	D
0	+0	0	0	0
5	+0	1	0	0
15	+0	1	0	1
15	+1	1	1	1
25	+0	1	1	0
25	+1	1	0	0
35	+0	1	0	1
35	+1	1	1	1
40	+0	0	1	1

2.45 Rising-edge triggered toggle flip-flop (T-flip-flop), with asynchronous active-high clear signal

```

2.46 (a) library IEEE;
        use IEEE.numeric_bit.all;

        entity ROM4_3 is
            port(ROMin: in unsigned(0 to 3);
                 ROMout: out unsigned(0 to 2));
        end ROM4_3;

        architecture Behavioral of ROM4_3 is
            type ROM16x3 is array (0 to 15) of unsigned(0 to 2);
            constant ROM1: ROM16x3 := ("000","001","001","010","001","010",
                                         "010","011","001","010","010","011","010","011","011","100");
            signal index: integer range 0 to 15;
        begin
            index <= to_integer(ROMin);
            ROMout <= ROM1(index);
        end Behavioral;

(b) library IEEE;
        use IEEE.numeric_bit.all;

        entity P_46 is
            port(A: in unsigned(11 downto 0);
                 count: out unsigned(3 downto 0));
        end P_46;

        architecture Behavioral of P_46 is
            component ROM4_3
                port(ROMin: in unsigned(0 to 3);
                     ROMout: out unsigned(0 to 2));
            end component;
            signal B, C, D: unsigned(0 to 2);
    
```

```

begin
  RO1: ROM4_3 port map (A(11 downto 8), B);
  RO2: ROM4_3 port map (A(7 downto 4), C);
  RO3: ROM4_3 port map (A(3 downto 0), D);
  count <= '0' & B + C + D;
end Behavioral;

```

(c)

```

ACountDCB 1111111111111111111100100100100
0101101011010111011010010
1000010111000101010010001

```

2.47

a	b	c	y7	y6	y5	y4	y3	y2	y1	y0
0	0	0	0	0	0	0	0	0	0	1
0	0	1	0	0	0	0	0	0	1	0
0	1	0	0	0	0	0	0	1	0	0
0	1	1	0	0	0	0	1	0	0	0
1	0	0	0	0	0	1	0	0	0	0
1	0	1	0	0	1	0	0	0	0	0
1	1	0	0	1	0	0	0	0	0	0
1	1	1	1	0	0	0	0	0	0	0

```

library IEEE;
use IEEE.numeric_bit.all;
entity decoder is
  port(A, B, C: in bit;
        X: out unsigned(7 downto 0));
end decoder;
architecture LUT of decoder is
  type ROM is array (0 to 7) of unsigned(7 downto 0);

  signal Table: ROM := ("00000001", "00000010", "00000100", "00001000",
                        "00010000", "00100000", "01000000",
                        "10000000"); signal index: unsigned(2 downto 0);
begin
  index <= A & B & C;
  X <= Table(to_integer(index));
end LUT;

```

2.48 (a) process(A)

```

variable Max: integer;
begin
  Max := A(1);
  for i in 2 to 20 loop
    if A(i) > Max then
      Max := A(i);
    end if;
  end loop;
end process;

```

(b) process(A)

```

variable Max, i: integer;
begin
  Max := A(1);
  i := 2;
  while i <= 20 loop
    if A(i) > Max then

```



```

        Max := A(i);
    end if;
    i := i + 1;
end loop;
end process;

```

2.49 architecture test1 of tester is

```

component Mealy
    port(X, CLK: in bit; Z: out bit);
end component;
signal XA: bit_vector(0 to 11) := "011011011100";
signal ZA: bit_vector(0 to 11) := "100110110110";
signal X, clk, Z: bit := '0';
begin
    clk <= not clk after 50 ns;
    M1: Mealy port map(X, clk, Z);
    process
    begin
        for i in 0 to 11 loop
            X <= XA(i) after 10 ns; --start first output
            immediately wait until clk = '1' and clk'event;
            assert (Z = ZA(i))
                report ("Error")
                severity error;
        end loop;
        report("sequence correct");
    end process;
end test1;

```

2.50 entity TestExcess3 is

```

end TestExcess3;

```

architecture test1 of TestExcess3 is

```

component Code_Converter is
    port(X, CLK: in bit;
        Z: out bit);
end component;
type bv_arr is array(1 to 10) of bit_vector(3 downto 0); constant
XA: bv_arr := ("0000", "0001", "0010", "0011", "0100",
    "0101", "0110", "0111", "1000", "1001"); constant ZA: bv_arr :=
("0011", "0100", "0101", "0110", "0111", "1000", "1001", "1010",
    "1011", "1100");
signal X, Z, CLK: bit := '0';
begin
    CLK <= not CLK after 50 ns;
    C1: Code_Converter port map (X, CLK, Z);
    process
    begin
        for i in 1 to 10 loop
            for j in 0 to 3 loop
                X <= XA(i)(j); --start first output immediately
                wait until clk'event and clk = '1';
                wait for 10 ns; --wait for gate delay
                assert (Z = ZA(i)(j))
                    report "sequence incorrect"
                    severity error;
                wait for 15 ns; --input will change 10+15 ns after
                edge end loop;
            end loop;
            report "all sequences correct";
        end process;
    end test1;

```

```

2.51 library IEEE;
    use IEEE.numeric_bit.all;

    entity testbench is
        port(time1: out time);
    end testbench;

    architecture test1 of testbench is
        signal clk, Ld8, Enable, S5: bit;
        signal Q: unsigned(3 downto 0);
        component countQ1 is
            port(ck1, Ld8, Enable: in bit; S5: out bit;
                Q: out unsigned(3 downto 0));
        end component;
    begin
        time1 <= now when S5 = '1' else 0 ns;
        clk <= not clk after 50 ns;
        Ld8 <= '1', '0' after 100 ns;
        Enable <= '0', '1' after 100 ns, '0' after 600 ns,
            '1' after 800 ns, '0' after 1800 ns;
        cnt1: countQ1 port map (clk, Ld8, Enable, S5, Q);
    end test1;

```

```

2.52 entity testSMQ1 is
    port(correct: inout Boolean);
end testSMQ1;
architecture testSM of test SMQ1 is
    component SMQ1
        port(X, CLK: in bit; Z: out bit);
    end component;
    constant answer: bit_vector(1 to 5) := "11010";
    signal X, Z, CLK: bit;
begin
    clk <= not clk after 50 ns;
    X <= '1', '0' after 100 ns, '1' after 300
    ns; SMQ1_1: SMQ1 port map (X, CLK, Z);
    process
    begin
        wait for 40 ns; --read output 10ns before rising edge of clock
        for i in 1 to 15 loop
            correct <= answer(i) = Z;
            wait for 100 ns;
            if correct = FALSE then exit; end if;
        end loop;
        wait;
    end process;
end testSM;

```

2.56

```

library IEEE;
use IEEE.numeric_bit.all;

entity bcd is
    port(Load, Clr, Enable, Clk, Up: in bit;
        D: in unsigned(3 downto 0);
        Cout: out bit; Q: out unsigned(3 downto 0));
end bcd;

architecture counter of bcd is
    signal Qout: unsigned(3 downto 0);

```

```

begin
  Q <= Qout;
  process(Clk,Clr)
  begin
    if Clr = '0' then Qout<="0000";
    elsif Clk'event and Clk = '1' then
      if Load = '1' and Enable = '1' then
        case D is
          when "1010"=> Qout<="0000" after 2 ns;
          when "1011"=> Qout<="0001" after 2 ns;
          when "1100"=> Qout<="0010" after 2 ns;
          when "1101"=> Qout<="0011" after 2 ns;
          when "1110"=> Qout<="0100" after 2 ns;
          when "1111"=> Qout<="0101" after 2 ns;
          when others => Qout <= D after 2 ns;
        end case;
      elsif Load = '0' and Enable = '1' and Up = '1' then
        if Qout = "1001" then Cout <= '1'; Qout<="0000" after 2
          ns; else Qout <= Qout + 1 after 2 ns; Cout <= '0';
        end if;
      elsif Load = '0' and Up = '0' and Enable = '1' then
        if Qout = "0000" then Cout <= '1'; Qout<="1001" after 2
          ns; else Qout <= Qout - 1 after 2 ns; Cout <= '0';
        end if;
      end if;
    end if;
  end process;
end counter;

```

2.57

```

library IEEE;
use IEEE.numeric_bit.all;

```

```

entity complex is
  port(clk50Mhz: in bit;
        clk: inout bit);
end complex;

```

```

architecture internal of complex is
  constant Fifty_Mil: integer := 50000000;
  signal counter_Big: integer range 1 to Fifty_Mil;

```

```

begin

  process(clk50Mhz)
  begin
    if clk50Mhz = '1' and clk50Mhz'event then
      if counter_Big = Fifty_Mil then counter_Big <= 1; clk<=not clk;
      else counter_Big<=counter_Big+1;
      end if;
    end if;
  end process;
end internal;

```

Lab Assignment #2

Guideline

This lab is to be done individually. Each person does his/her own assignment and turns it in.

Objective

To learn designing basic sequential circuits in VHDL and implementing them on an FPGA.

Problem 1: Excess-3 code converter design

In this problem, you will be designing an FSM using three different styles of VHDL coding: behavioral, dataflow, and structural. The following is the problem for which you will be designing the FSM:

A sequential circuit has one input (X), a clock input (CLK), and two outputs (S and V). X , S and V are all one-bit signals. X represents a 4-bit binary number N , which is input least significant bit first. S represents a 4-bit binary number equal to $N + 3$, which is output least significant bit first. At the time the fourth input occurs, $V = 1$ if $N + 3$ is too large to be represented by 4 bits; otherwise, $V = 0$. The value of S should be the proper value, not a don't care, in both cases. The circuit always resets after the fourth bit of X is received. Assume the sequential circuit is implemented with the following state table. The outputs are (S, V). All state changes occur on the falling edge of the clock pulse.

Present State	Next State		Output	
	X=0	X=1	X=0	X=1
S0	S1	S2	1,0	0,0
S1	S3	S4	1,0	0,0
S2	S4	S4	0,0	1,0
S3	S5	S5	0,0	1,0
S4	S5	S6	1,0	0,0
S5	S0	S0	0,0	1,0
S6	S0	S0	1,0	0,1

- a. Write a *behavioral VHDL description* using the state table shown above. Compile and simulate your code using the following test sequence:

$$X = 1011 \ 1100 \ 1101 \ \epsilon$$

The first input bit is at the far right. This is the LSB of the first 4-bit value. Therefore, you will be adding 3 to 13, then to 12, and then to 11. While simulating, keep the period of the CLK to be 10ns. Change X 1/4 clock period after the rising edge of the clock.

- b. Write a *data flow VHDL description* using the next state and output equations to describe the state machine. You can use Logic Aid to derive the logic equations. Assume the following state assignment:

$$S0 = 000, S1 = 010, S2 = 001, S3 = 101, S4 = 011, S5 = 100,$$

$S6 = 111$ Compile and simulate your code using the same test sequence and timing as (a).

- c. Write a *structural model* of the state machine in VHDL that contains the interconnection of gates and D flip-flops. Compile and simulate your code using the same test sequence and timing as (a).

Problem 2: BCD Counter Design

Implement a 1 digit BCD (binary coded decimal) counter. It should be a synchronous (4-bit) up/down decade counter with output Q that works as follows: All state changes occur on the rising edge of the CLK input, except the asynchronous clear (CLR). When $CLR = 0$, the counter is reset regardless of the values of the other inputs. You can keep the time period of the CLK signal to 10ns for simulating your design.

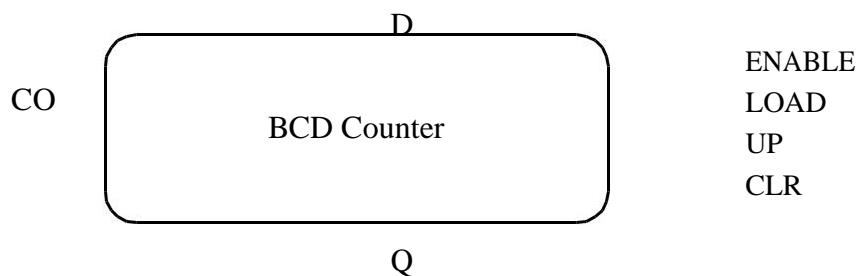

If the $LOAD = ENABLE = 1$, the data input D is loaded into the counter. If $LOAD = 0$ and $ENABLE = UP = 1$, the counter is incremented.

If $LOAD = 0$, $ENABLE = 1$, and $UP = 0$, the counter is decremented.

If $ENABLE = 1$ and $UP = 1$, the carry output (CO) = 1 when the counter's value is 9. If $ENABLE = 1$ and $UP = 0$, the carry output (CO) = 1 when the counter's value is 0.

- a. Write a VHDL description of the counter. You may implement your design in any style you wish. It will be easier to use a behavioral description which can be either written in the algorithmic way (eg. $Count \leq Count + 1$ – Figure 2.46 in the text) or a state machine way (eg. $State \leq Next_State$ – Figure 2.54/2.56 in the text). You may also use dataflow or structural descriptions, although that will be more work. Use the following simulation for your waveforms:

1. Load counter with 6
2. Increment counter four times. You should get 9 and then 0.
3. Decrement counter once. You should get 9.
4. Clear the counter.

- b. Write a VHDL description of a decimal counter that uses two of the above counters to form a two-decade decimal up/down counter that counts up from 00 to 99 or down from 99 to 00. In other words, instantiate (port map) two single digit counters in a top module (the two-digit counter). You may need some extra logic in the top module too other than these instantiations. The top module will have these inputs and outputs: CLR , CLK , $ENABLE$, $LOAD$, UP , $D1$, $D2$, $Q1$, $D2$, CO . Use the following simulation for your waveforms:

1. Load counter with 97
2. Increment counter five times.
3. Do nothing for 2 clock periods
3. Decrement counter four times.
4. Clear the counter.

Problem 3: Synthesizing and implementing the BCD counter on the FPGA

Use the code for the single digit BCD counter that you wrote in Problem 2a. Before you synthesize it and implement it on the board, you will have to modify your code a little bit. This is because the CLK signal available on the board is a high frequency signal (50 MHz). If you use this high frequency for your circuit, you will not be able to give proper inputs or see proper outputs to your design.

So, you need to add a clock divider to your VHDL description. Create two more entities in your design. Call one as *top* and another as *divider*. Make connections as shown in the following figure. Look at the codes given in the end of this document, understand them and see how they can be used as clock dividers.

Ensure that there are no latches in your design. Xilinx ISE will report these in the Synthesis report. You need to eliminate such warnings. You may want to read the synthesis guidelines “Tips for writing synthesizable code” available on Blackboard.

To look for latches in your synthesized design, open the synthesis report generated by ISE by clicking “View Synthesis Report” under the “Synthesize-XST” option. In the synthesis report, look for “Macro Statistics” and see if any latches are being shown. Alternatively, you can look for “cell usage” in the report and there should not be any cells under “Flip Flops/Latches” having names starting with “L”.

Also, after adding the counter/clock divider block to your design, simulate the top entity in Modelsim before directly synthesizing using ISE to ensure that the counter/divider works. And while simulating, reduce the large values (like 5000000) in the counter to small values (say 50), so that simulation takes less time and the waveforms are legible. Don't forget to switch to the correct (large) value before synthesizing.

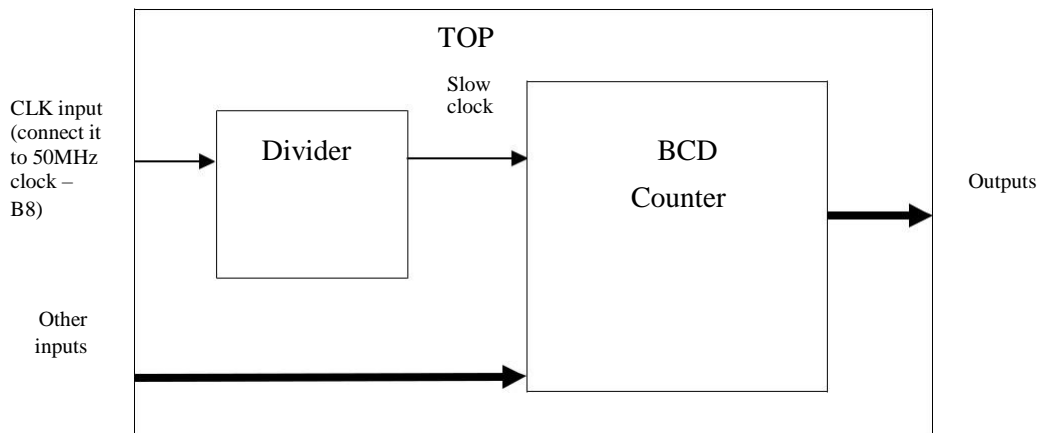

Synthesize the top module (which includes the divider and the 1-digit bcd counter) and use the following pin assignments. Download the design onto the board and make sure it works as expected.

LOAD	BTN0
D	SW[3:0]
ENABLE	SW4
UP	SW5
CLK	B8
COUNT	LED[3:0]
CO	LED4

CLR _____	SW6 _____
-----------	-----------

Useful Information

1. Don't limit your testing to the input sequences mentioned with the problem statement. During the checkouts, the TAs will apply several input combinations to test your design. So, make sure to do a thorough testing of your design using sufficient number of inputs.
2. While simulating your design, it is always a good idea to stagger your inputs with respect to the active clock edge. For example, if your active clock edge is occurring at 10ns, apply your inputs sometime before 10ns, say at 8ns. This ensures that when your design was clocked, the input was successfully read. If your active edge occurs at 10ns and your input also changes at 10ns, then it becomes hard to see whether the input was successfully captured by the clock edge or not.

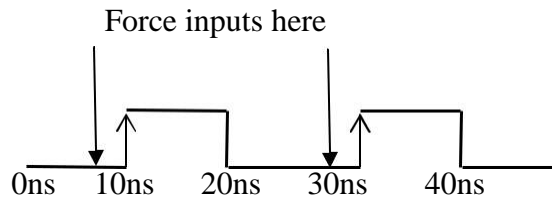

3. A state machine can be designed using either a single process statement (like Figure 2.56 in the text) or using two process statements (like Figure 2.54 in the text). Both ways are correct. However, it is easier to design it using a single process statement. Generally, the single process statement partakes less debugging effort. This is good guideline to observe during the entire semester.

Submission Details

All parts of this lab are to be submitted on Blackboard. No hard- copy submission is needed. For each problem, please zip all your files into a single folder with the following naming scheme: *Lastname_Problem#.zip*

Problem	Submission Requirements
1	VHDL file(s)
2	VHDL file(s)
3	Do-file VHDL file(s) Bit-file and UCF File

Checkout Details

During your checkout you will be expected to demonstrate each of the problems in the assignment and answer verbal questions about the assignment.

Example 1

```

library IEEE;
use IEEE.numeric_bit.ALL;

entity simpleCounter is
  Port ( clk50Mhz : in
         bit;
         led : out bit);
end simpleCounter;

architecture Behavioral of simpleCounter
is signal counter: unsigned (26 downto
0); signal cnt_temp: bit_vector(26
downto 0); begin

process (clk50Mhz)
begin
  if clk50MHZ = '1' and clk50Mhz'event then
    counter <= counter + 1;           --increment counter every 20 ns (1/ 50 Mhz) cycle.
  end if;
end process;

cnt_temp <= bit_vector(counter);
led <= cnt_temp(26);                 -- (2^26 / 50E6) = 1.34 seconds

end Behavioral;

```

Example 2

```

library IEEE;
use IEEE.numeric_bit.ALL;

entity complex is
  Port ( clk50Mhz : in
         bit; led : inout bit
         );
end complex;

architecture Behavioral of complex is
signal counter: integer range 1 to 50000000;
begin

process (clk50Mhz)
begin
if clk50MHZ = '1' and clk50Mhz'event then
  if counter = 50000000 then counter <= 1; led <= not
  led; else counter <= counter + 1;
  end if;
end if;

```



```
end process;  
end Behavioral;
```