

**Solution Manual for Engineering Design Process 3rd Edition Haik Sivaloganathan and Shahin ISBN 1305253280 9781305253285**

Full link download

Solution Manual: <https://testbankpack.com/p/solution-manual-for-engineering-design-process-3rd-edition-haik-sivaloganathan-and-shahin-isbn-1305253280-9781305253285/>

**Chapter 2**

1. Table 2.3 breaks down the number of major jobs or activities involved in painting a two-story house.

(a) Develop a CPM network.

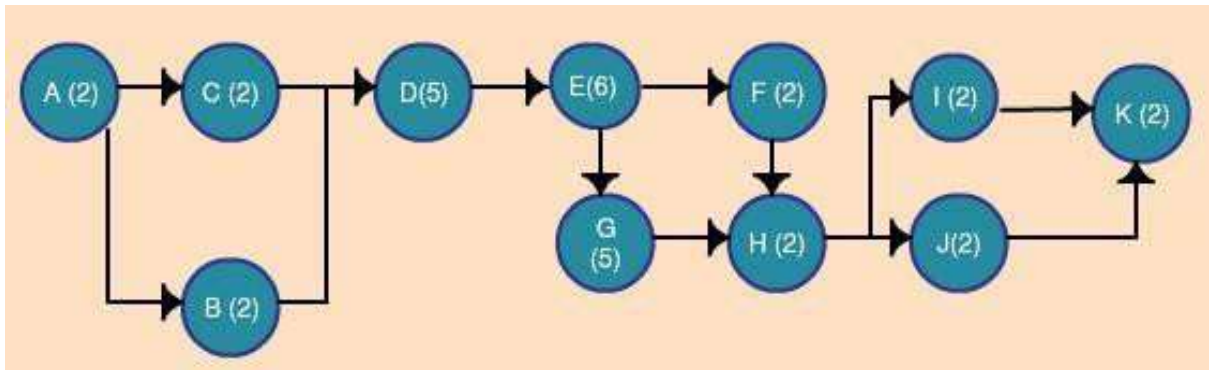

(b) Determine the critical path of the network.

A-C-D-E-G-H-J-K

(c) Determine the expected project’s duration time period.

26 weeks

**TABLE 2.3** Problem 1

Activity	Identification	Predecessor	Duration
Contract signed	A	—	2
Purchase of material	B	A	2
Ladder and staging in site	C	A	2
Preparation of surface	D	C,B	5

Base coat complete	E	D	6
Base coat inspected	F	E	2

Trim coat complete	G	E	5
Trim coat inspected	H	G,F	2
Final inspection	I	H	2
Removal of staging	J	H	2
Final cleanup	K	I,J	2

2. Assume that the optimistic, most likely, and pessimistic activity times are as given in Table 2.4.

(a) Complete the table.

$$T_e = \frac{T_o + 4T_m + T_p}{6}$$

$$\text{Use } s = \frac{T_p - T_o}{6}$$

$$V = s^2$$

(b) Determine the probability of finishing the job in 32 weeks.

$$Z = \frac{D - T_e}{s\sqrt{4.66}} = \frac{32 - 32.33}{s\sqrt{4.66}} = -0.07$$

**TABLE 2.4** Problem 2

Pessimistic	Most Likely	Optimistic	Expected Time	Variance
3	2	1	2	0.11
3	2	1	2	0.11
3	2	1	2	0.11
7	5	3	5	0.44

9	6	4	6.17	0.69
3	2	1	2	0.11
7	5	4	5.17	0.25
3	2	1	2	0.11
3	2	1	2	0.11
3	2	1	2	0.11
3	2	1	2	0.11

3. You should work on this activity during lab hours.

(a) Develop a CPM network and determine the critical path for the events defined in the Gantt chart in Figure 2.1.

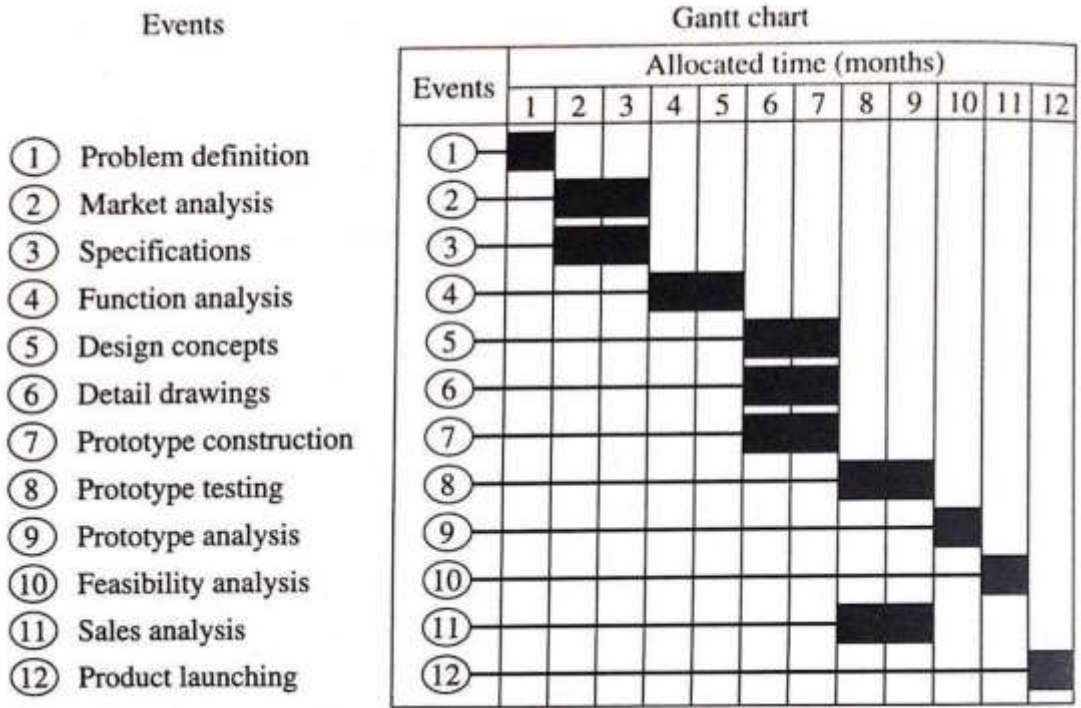

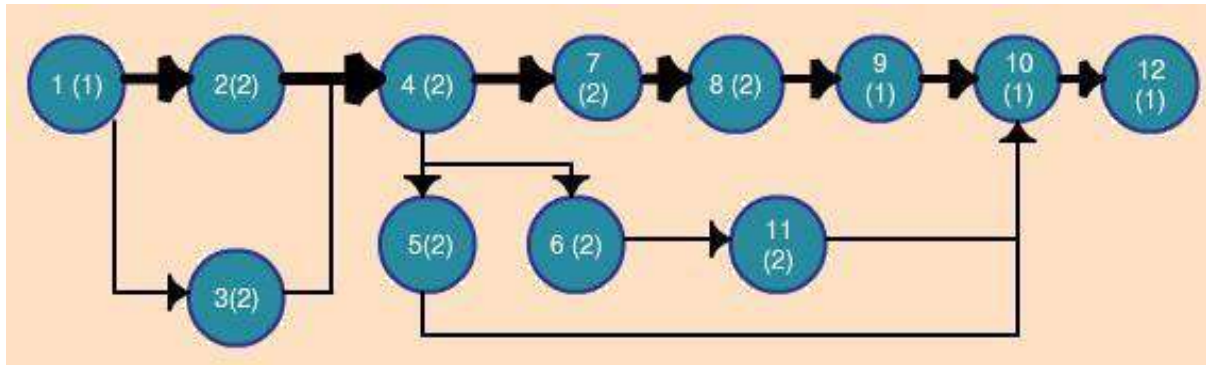

(b) Develop a Gantt chart for the events defined in Table 2.2.

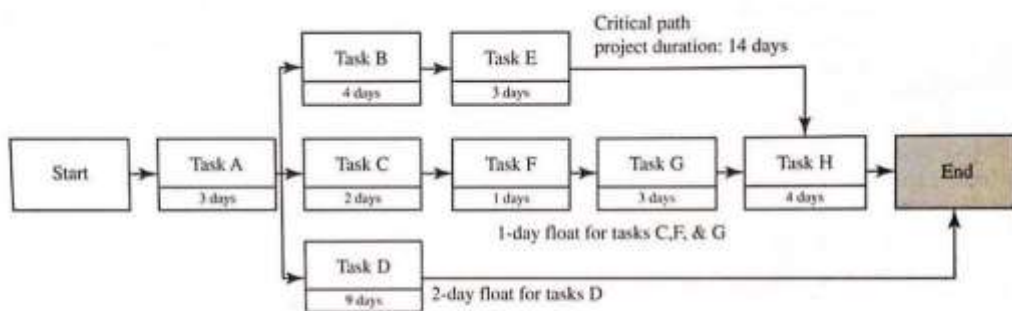

	1	2	3	4	5	6	7	8	9	10	11	12	13
Task A	█	█	█										
Task B			█	█	█	█	█						
Task C			█	█									
Task D			█	█	█	█	█	█	█	█	█	█	
Task E						█	█	█					
Task F					█								
Task G						█	█	█					
Task H									█	█	█	█	

(c) For the events defined in Table 2.5,

- i. Complete the table.
- ii. Draw the PERT network.

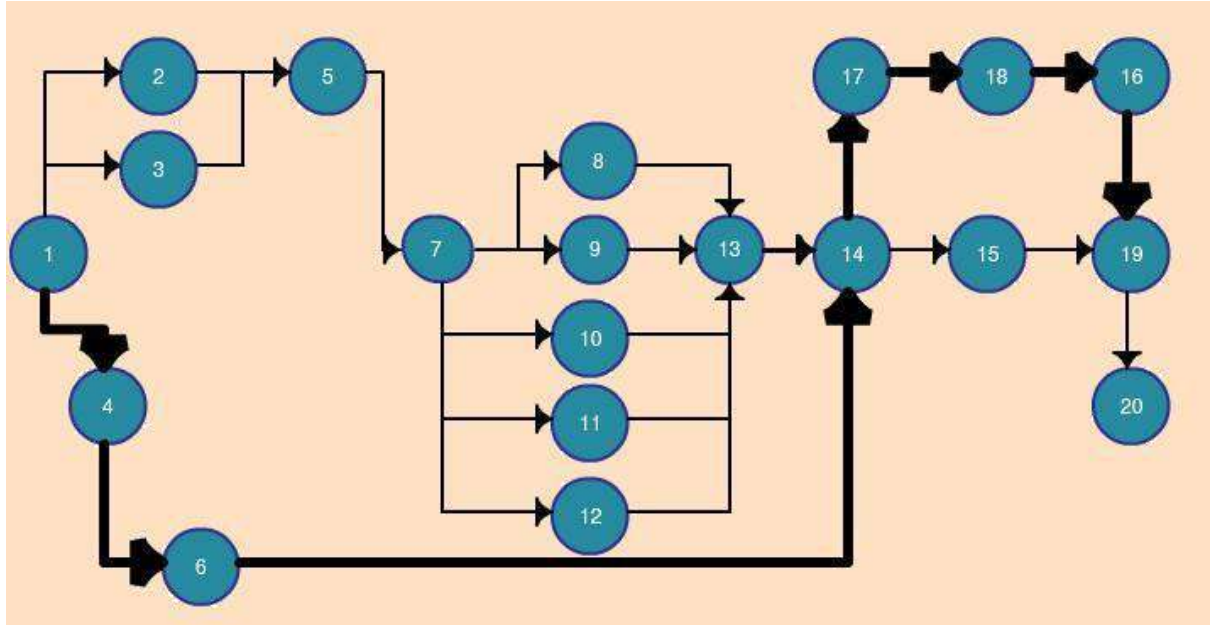

critical path 1-4-6-14-17-18-16-19-20

- iii. Determine the probability of finishing the task on time if the design due date is later than 95 days.

$$Z = \frac{D - T_e}{\sigma} = \frac{95 - 90.17}{\sqrt{8.17}} = 0.59$$

Use the table below to calculate  $T_e$  and  $\sigma$  for the critical path

**TABLE 2.5** Problem 3

Predecessor	Optimistic	Most Likely	Pessimistic	Expected	Stdev	Variance
1	3	5	8	5.17	0.83	0.69
1	4	6	9	6.17	0.83	0.69
3	3	4	5	4.00	0.33	0.11
2	2	3	4	3.00	0.33	0.11
5	3	4	5	4.00	0.33	0.11
1	8	12	14	11.67	1.00	1.00
4	14	18	21	17.83	1.17	1.36
7	5	10	14	9.83	1.50	2.25
7	5	10	14	9.83	1.50	2.25
7	5	10	14	9.83	1.50	2.25
7	5	10	14	9.83	1.50	2.25

7	5	10	14	9.83	1.50	2.25
12	4	6	10	6.33	1.00	1.00
11	4	6	10	6.33	1.00	1.00
10	4	6	10	6.33	1.00	1.00
9	4	6	10	6.33	1.00	1.00
8	4	6	10	6.33	1.00	1.00
13	10	12	18	12.67	1.33	1.78
6	16	18	24	18.67	1.33	1.78
14	7	10	15	10.33	1.33	1.78
14	10	15	22	15.33	2.00	4.00
17	5	9	9	8.33	0.67	0.44
18	4	6	8	6.00	0.67	0.44
16	6	8	12	8.33	1.00	1.00
15	3	8	12	7.83	1.50	2.25
19	3	4	5	4.00	0.33	0.11

#### 2.7.2 Individual Activities

4. Define the following terms:

(a) *CPM (Critical Path Method): Management tool that assumes that activities durations are known with certainty*

(b) *Gantt chart: A chart with series of blocks that account for activities in a project during an assigned period.*

(c) *PERT (Program Evaluation Review Technique): Management tool that assumes activity durations are random*

5. Assume that an engineering course term project is broken down into a number of major jobs or activities, as shown in Table 2.6.

(a) Draw a Gantt chart.

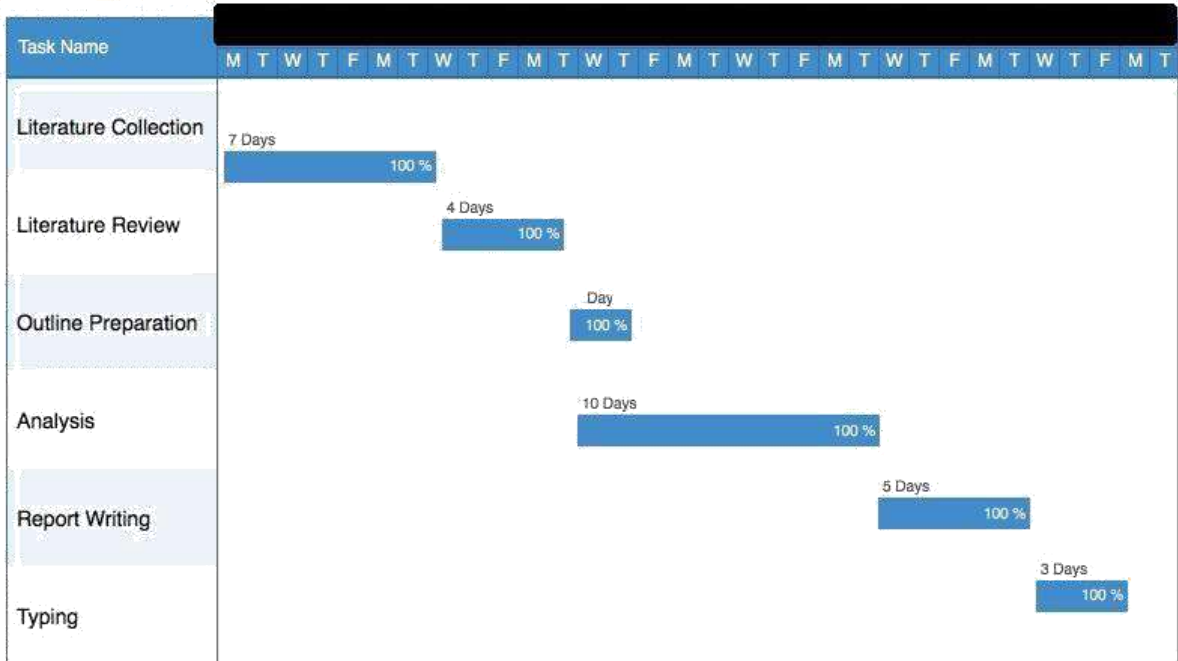

(b) Develop a CPM network.

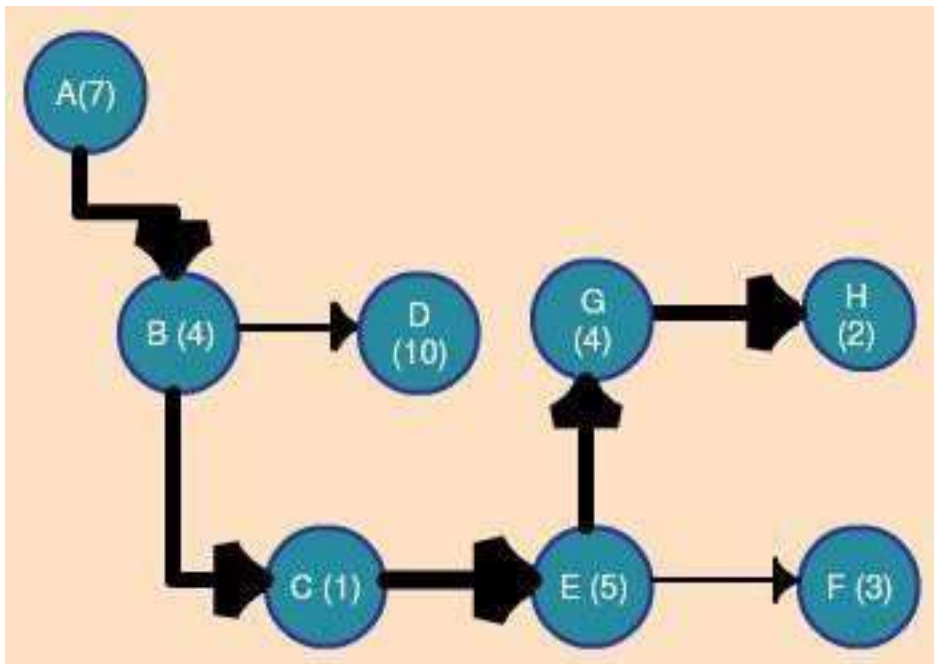

(c) Determine the critical path of the network.

(d) Determine the project duration time period.



**TABLE 2.6** Project

<b>Activity Description</b>	<b>Activity Identification</b>	<b>Immediate Predecessor Activity</b>	<b>Activity Duration (Days)</b>
Literature collection	A	—	7
Literature review	B	A	4
Outline preparation	C	B	1
Analysis	D	B	10
Report writing	E	C	5
Typing	F	E	3
Revision	G	E	4
Final draft	H	G	2

Assume that, for example, the optimistic, most likely, and pessimistic activity times are as shown in Table 2.7. Calculate each activity's expected time and variance along with the probability of accomplishing the design project in 2.5 weeks. In addition, calculate each event's earliest and latest event times.

**TABLE 2.7** Activity Time Estimates (Weeks)

<b>Pessimistic</b>	<b>Most Likely</b>	<b>Optimistic</b>	<b>Expected Time</b>	<b>Variance</b>
4	2	1	2.16	0.25
3	2	1	2	0.11
4	2	1	2.16	0.25
8	5	3	5.16	0.7
5	4	2	3.83	0.25
7	4	3	4.33	0.44
5	3	2	3.17	0.25
5	3	2	3.17	0.25
9	6	3	6	1
10	4	2	4.17	0.69



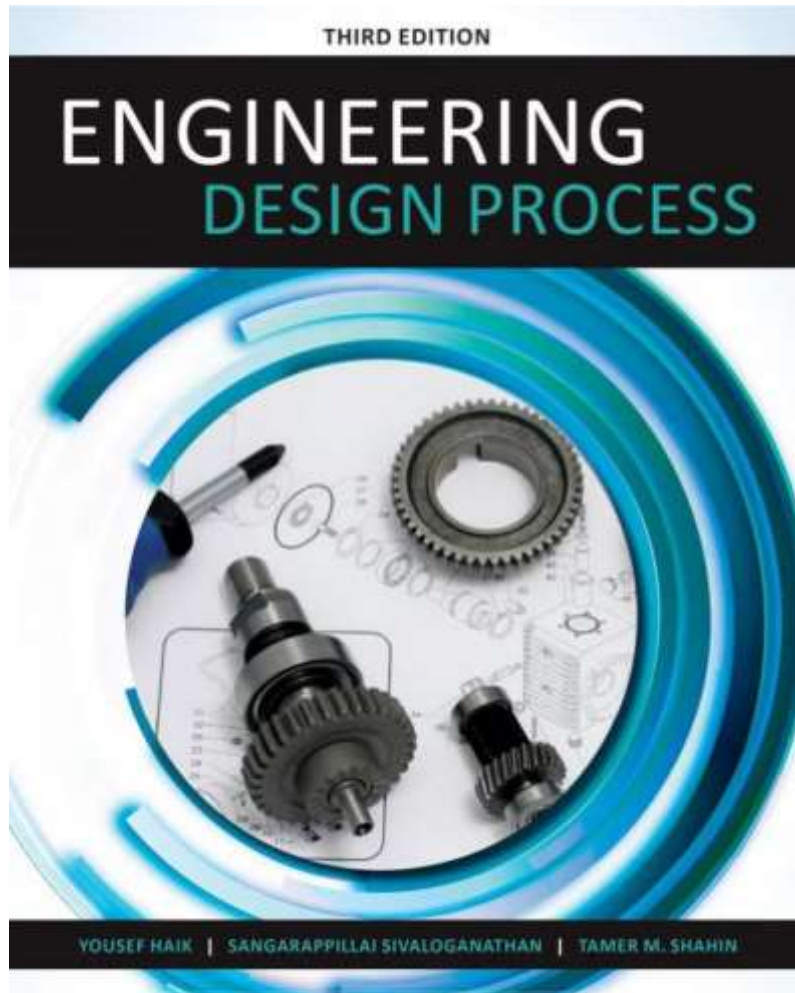

# Engineering Design Process

## Chapter 2: Essential Transferable Skills

## 2.1 – Objectives

1. Identify essential, prerequisite skills for design process.
2. Appreciate importance and dynamics of working in teams.
3. Develop a project schedule using existing tools.
4. Practice and improve research & communications skills.

## 2.2 – Working in Teams

- A team is a collection of individuals
  - Whose work is interdependent and
  - Who are collectively responsible for a performance outcome
- Features of a team include
  - Dynamic exchange of information & resources
  - Coordinated task activities
  - Continuous adjustment to team & task demands
  - Shared authority & accountability for performance

## 2.2 – Working in Teams

- Teams can be formed from various model. This textbook uses the brain model.
- 2.2.1 – Forming a team
  - The Hermann model is useful for classifying individuals into 4 basic thinking styles.
  - A team composed of members with all 4 thinking styles will be successful.
  - The 4 styles are analytical/logical, organized/planning, holistic/intuitive and social/communicative.

## 2.2 – Working in Teams

- 2.2.2 – Dynamics of a Team
  - Teams evolve according to 4 stages:
    1. Forming
    2. Storming
    3. Norming
    4. Performing
  - 4 behaviors are needed for effective team work
    1. Communication team behavior
    2. Decision making team behavior
    3. Collaboration team behavior
    4. Self management team behavior



## 2.2 – Working in Teams

- 2.2.2 – Dynamics of a Team
  - An effective 4-member team can organize into the following distinct roles:
    1. Captain – skilled in self-management team behavior
    2. Chief Engineer – skilled in decision making team behavior
    3. Human Resources person – skilled in collaboration team behavior
    4. Spokesperson – skilled in communication team behavior

## 2.3 – Scheduling

- 2.3.1 – Gantt Chart
  - The Gantt chart is a form of bar chart and is created as follows:
    1. List all project events/milestones in an ordered list
    2. Estimate the time required for each event
    3. List the starting & end time for each event
    4. Represent this information in a bar chart

# 2.3 – Scheduling

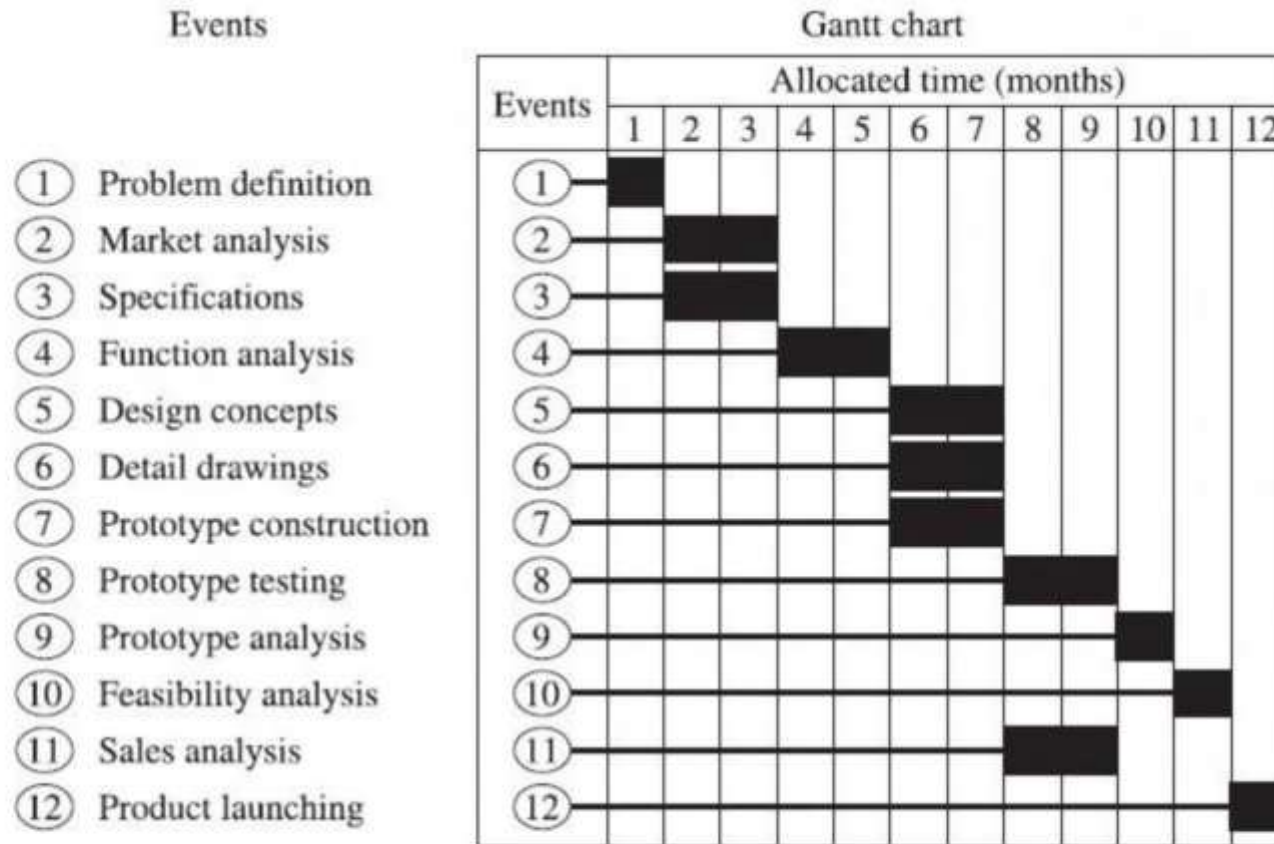

Figure 2.1: Gantt Chart

## 2.3 – Scheduling

- 2.3.2 – CPM/PERT
  - CPM – Critical Path Method
  - PERT- Program Evaluation & Review Technique
  - CPM/PERT is used over 65% of time in US manufacturing companies
  - CPM/PERT projects have following characteristics:
    1. Clearly defined activities/jobs in a project
    2. Activities/jobs proceed uninterrupted once started
    3. Activities/tasks are independent w.r.t starting, stopping, and performed in a prescribed sequence
    4. Activities/jobs are ordered in sequential manner

## 2.3 – Scheduling

- 2.3.3 – CPM/PERT Definitions
  1. Event (node) – represented by a circle and a number, this stands for an event such as starting or stopping of a stage
  2. Activity – effort needed to carry out a portion of project
  3. Network paths – Paths needed/used to reach event or project termination point
  4. Critical path – Longest path (w.r.t time) through the PERT/CPM network
  5. Earliest Event Time (EET) – Earliest time at which an event occurs if preceding events completed at schedule

## 2.3 – Scheduling

- 2.3.3 – CPM/PERT Definitions
  6. Latest Event Time (LET) – Latest time at which an event can be reached without delaying project completion
  7. Total float – Latest time of an event minus earliest time of preceding event and duration time of in-between activity

# 2.3 – Scheduling

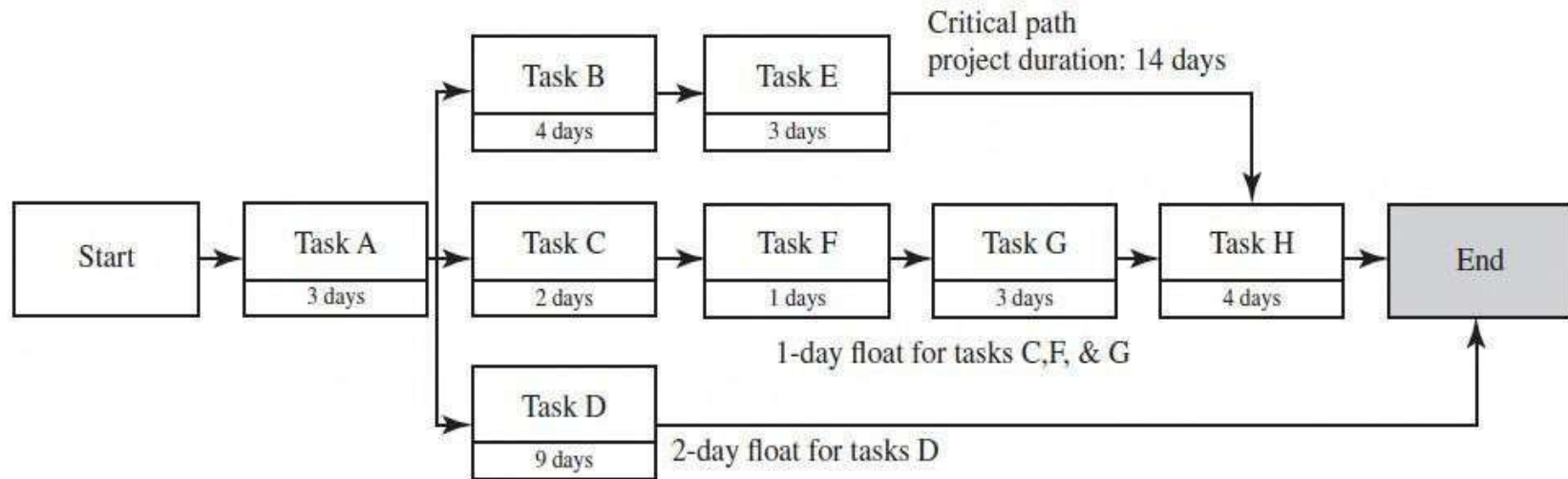

Figure 2.2: CPM/PERT Chart



## 2.3 – Scheduling

- 2.3.4 – CPM/PERT Network Development
  - The steps to develop a CPM network are:
    1. Break down design into individual activities.
    2. Estimate required time for each activity.
    3. Determine activity sequence.
    4. Construct CPM network using defined symbols.
    5. Determine critical path of the network.



## 2.3 – Scheduling

- 2.3.4 – CPM/PERT Network Development
  - The steps to develop a PERT network are:
    1. Break down design into individual activities.
    2. Determine activity sequence.
    3. Construct PERT network using defined symbols.
    4. Obtain expected time to perform each activity using the formula:

$$T_e = (x + 4y + z) / 6$$

5. Determine the critical network path.

## 2.3 – Scheduling

- 2.3.4 – CPM/PERT Network Development
  6. Compute variance associated with expected time of each activity with the formula

$$s^2 = \frac{x^2 + z^2 + x^2}{6}$$

6

7. Obtain probability of accomplishing design project on the stated date using the formula

$$W = \frac{T - T_L}{\sqrt{S_{cr}^2}}$$

## 2.3 – Scheduling

Table 2.1: Probability Table

<b>W</b>	<b>Probability</b>
-3.0	0.0013
-2.5	0.006
-2.0	0.023
-1.5	0.067
-1.0	0.159
0.5	0.309
0.0	0.5
0.5	0.69
1.0	0.84
1.5	0.933
2.0	0.977
2.5	0.994
3.0	0.999

## 2.4 – Research Skills

- In the design process, research is pursued at all stages, but especially during customer requirement collection and market analysis stages.
  - The Big6 method identifies 6 categories of research skills:
    1. Task definition
    2. Information seeking strategies
    3. Location and access
    4. Use of information
    5. Synthesis
    6. Evaluation

## 2.5 – Technical Writing & Presentation

- The end of the design process often requires a technical report, which is disseminated to a diverse audience.
- Readers often assume that the quality of the report reflects the quality of the design project.
- Therefore, effective report writing is essential to market the design to stakeholders.

## 2.5 – Technical Writing & Presentation

- The outline of a typical report format is:
  1. Cover Page – Title, Address, Author name(s)
  2. Summary – Intended for broad audience, including executives. Should have a conclusion
  3. Table of Contents
  4. List of figures, list of tables
  5. Introduction – provides background and possibly market analysis
  6. Design Process – provides details of procedures followed in design process

## 2.5 – Technical Writing & Presentation

- The outline of a typical report format is:
  7. Discussion – contains comprehensive examination of results. Subsections may include technical analysis, equipment used, details of mock-up model, procedures, details of final results etc
  8. Conclusion
  9. References
  10. Appendices – details deemed beyond the main scope of the report. Can contain as many subsections as necessary

## 2.5 – Technical Writing & Presentation

- 2.5.1 – Steps in Writing a Report
  1. **P** : Plan the Writing
  2. **O** : Outline the Report
  3. **W** : Write
  4. **E** : Edit
  5. **R** : Rewrite



## 2.5 – Technical Writing & Presentation

- 2.5.1 – Steps in Writing a Report
  - Some attributes of good report writing are:
    1. Objective, concise and methodical writing.
    2. Deliver written material on time.
    3. Strive for clarity in writing.
    4. Effectively answer readers' questions as they arise.
    5. Give a good first impression and read coherently.
    6. Contain effective introduction and summary.
    7. Avoid vague and superfluous phrases.

## 2.5 – Technical Writing & Presentation

- 2.5.2 – Illustration Guidelines
  - Some guidelines for preparing effective visuals/illustrations are
    1. Reference all illustrations in the text.
    2. Reference data sources.
    3. Specify all scales, axes, units etc., and provide a caption/title for every illustration.
    4. Carefully plan placement of visuals.
    5. Avoid putting too much data in one visual.
    6. Spell out words rather than use abbreviations.
    7. Use a list of figures if more than 5 illustrations are present in the report.

## 2.5 – Technical Writing & Presentation

- 2.5.3 – Mechanics of Writing
  - Paragraph Structure – use a topic sentence; use a single theme per paragraph
  - Sentence Length – keep sentences as short as possible, and convey one idea per sentence
  - Pronouns – Use nouns instead of 'it', 'this', 'that'. Avoid using personal pronouns like 'I', 'you', 'they'.
  - Spelling and Punctuation – these errors are inexcusable in the final draft of the report
  - Tense – Use past tense to describe work done in the past. Present tense should refer to ideas and items in the report. Future tense is for making predictions from data, or for results applicable in the future.

## 2.6 – Presentation Style

- 2.6.1 – Objective
  - Every presentation must have a clearly focused objective.
  - If everything goes perfectly, what do I intend to achieve?
  - Determine your audience and their education level.
  - Practice presentations in advance through role playing to evaluate if your objective is being achieved in your presentation.

## 2.6 – Presentation Style

- 2.6.2 – Oral Presentation Obstacles
  - Oral presentation requires lots of creativity.
  - You have to be confident in your idea/design to effectively sell it to others.
  - People tend to resist change, and may raise objections like:
    - We tried it before; its never been done before; the idea is unrealistic etc.
  - Only 70% of spoken word is initially understood – repetition and redundancy help audience understanding.
  - People like simple explanations, and tend to see things from their own perspective.

## 2.6 – Presentation Style

- 2.6.3 – Oral Presentation Do's and Don'ts
  - Know audience thoroughly, and make eye contact with them majority of the time.
  - Stay within the allotted time.
  - Avoid technical jargon. Use jokes/anecdotes etc., but only if you can effectively deliver them.
  - Practice repeatedly in advance.
  - Understand your message clearly.
  - The presentation should be presented in a logical order of messages.
  - Present the material in a clever way, but not in a cheap, sensational way.

## 2.6 – Presentation Style

- 2.6.4 – Oral Presentation Techniques
  - Visual aids convey information more effectively and efficiently than text in most cases.
  - Slides should be kept under 1 minute.
  - Slides should contain a single idea generally.
  - Never read directly from the slide.
  - Use well labeled graphs to show variations, trends etc.
  - Include title, outline and summary slides in your presentation.
  - Color should enhance communication, not distract from it.

## 2.6 – Presentation Style

- 2.6.5 – Question & Answer Session
  - Allow the questioner to complete the question before answering.
  - Avoid being argumentative.
  - Avoid making questioner feel the question is stupid.
  - Adjourn meeting if questions slack off.
  - Thank the audience one more time after the Q&A session



