

Solution Manual for Engineering Mechanics Statics in SI Units 14th Edition by Hibbeler ISBN 1292089237 9781292089232

Full download link at:

<https://testbankpack.com/p/solution-manual-for-engineering-mechanics-statics-in-si-units-14th-edition-by-hibbeler-isbn-1292089237-9781292089232/>



2-1.

Determine the magnitude of the resultant force $\mathbf{F}_R = \mathbf{F}_1 + \mathbf{F}_2$ and its direction, measured clockwise from the positive u axis.

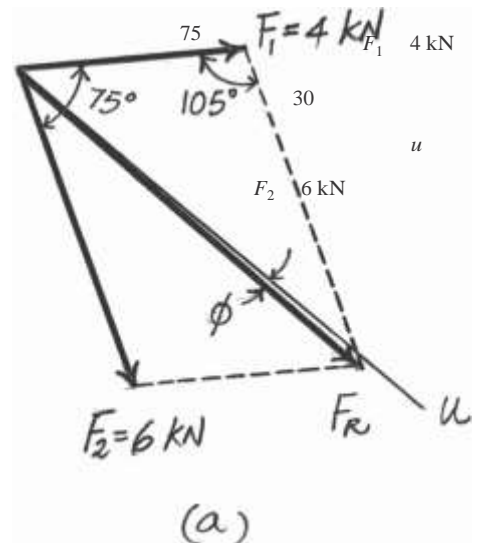

Ans.

Solution

Parallelogram Law. The parallelogram law of addition is shown in Fig. *a*,
Trigonometry. Applying Law of cosines by referring to Fig. *b*,

$$F_R = \sqrt{24^2 + 6^2 - 2(4)(6) \cos 105} = 8.026 \text{ kN} = 8.03 \text{ kN}$$

Using this result to apply Law of sines, Fig. *b*,

$$\frac{\sin u}{6} = \frac{\sin 105}{8.026}; \quad u = 46.22$$

Thus, the direction \mathbf{f} of \mathbf{F}_R measured clockwise from the positive u axis is

$$\mathbf{f} = 46.22 - 45 = 1.22$$

Ans.

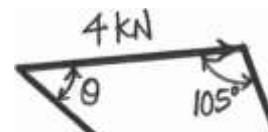

Ans:
f = 1.22

2-2.

Resolve the force F_1 into components acting along the u and v axes and determine the magnitudes of the components.

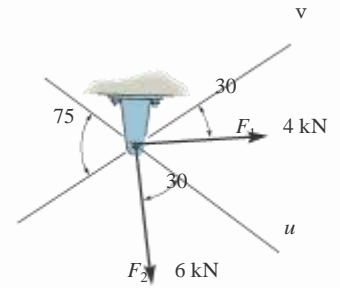

Solution

Parallelogram Law. The parallelogram law of addition is shown in Fig. *a*,
Trigonometry. Applying the sines law by referring to Fig. *b*.

$$\frac{(F_1)_v}{\sin 45} = \frac{4}{\sin 105} ; \quad (F_1)_v = 2.928 \text{ kN} = 2.93 \text{ kN}$$

$$\frac{(F_1)_u}{\sin 30} = \frac{4}{\sin 105} ; \quad (F_1)_u = 2.071 \text{ kN} = 2.07 \text{ kN}$$

Ans.

Ans.

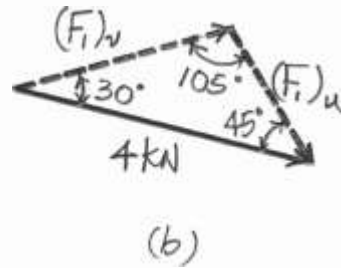
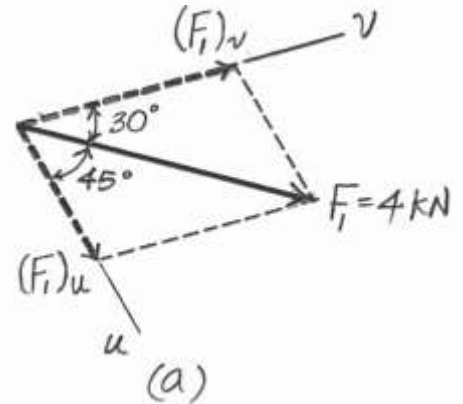

Ans:

$$(F_1)_v = 2.93 \text{ kN}$$

$$(F_1)_u = 2.07 \text{ kN}$$

2-3.

Resolve the force F_2 into components acting along the u and v axes and determine the magnitudes of the components.

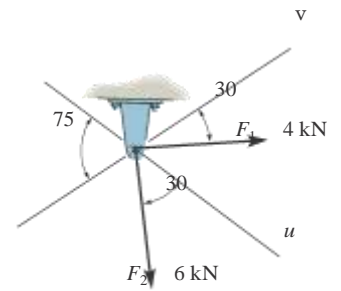

Solution

Parallelogram Law. The parallelogram law of addition is shown in Fig. *a*,
Trigonometry. Applying the sines law of referring to Fig. *b*,

$$\frac{(F_2)_u}{\sin 75} = \frac{6}{\sin 75} ; \quad (F_2)_u = 6.00 \text{ kN} \quad \text{Ans.}$$

$$\frac{(F_2)_v}{\sin 30} = \frac{6}{\sin 75} ; \quad (F_2)_v = 3.106 \text{ kN} = 3.11 \text{ kN} \quad \text{Ans.}$$

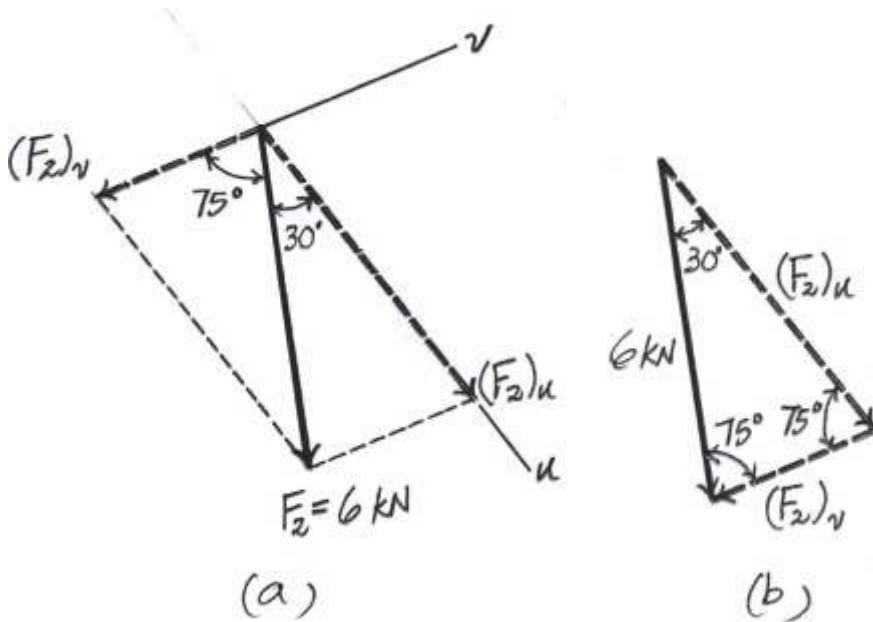

Ans:
 $(F_2)_u = 6.00 \text{ kN}$
 $(F_2)_v = 3.11 \text{ kN}$

*2-4.

If $\theta = 60^\circ$ and $F = 450 \text{ N}$, determine the magnitude of the resultant force and its direction, measured counterclockwise from the positive x axis.

SOLUTION

The parallelogram law of addition and the triangular rule are shown in Figs. *a* and *b*, respectively.

Applying the law of cosines to Fig. *b*,

$$F_R = \sqrt{700^2 + 450^2 - 2(700)(450) \cos 45^\circ}$$

$$= 497.01 \text{ N} \quad 497 \text{ N}$$

Ans.

This yields

$$\frac{\sin \alpha}{700} = \frac{\sin 45^\circ}{497.01} \quad \alpha = 95.19^\circ$$

Thus, the direction of angle ϕ of \mathbf{F}_R measured counterclockwise from the positive x axis, is

$$\phi = \alpha + 60^\circ = 95.19^\circ + 60^\circ = 155^\circ$$

Ans.

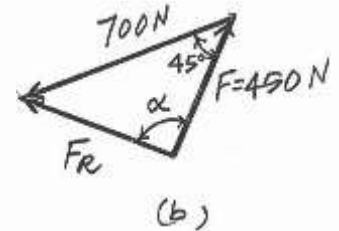
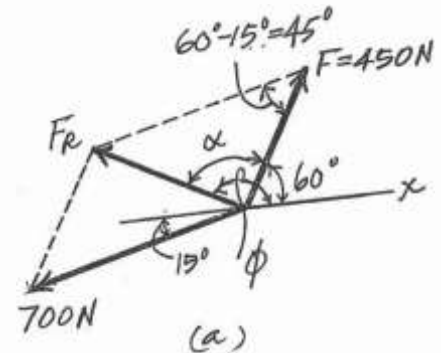
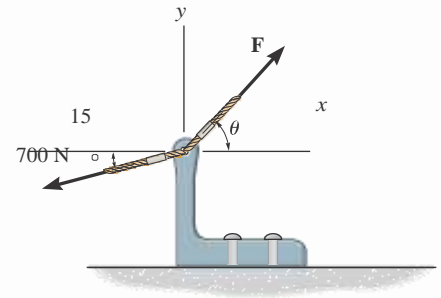

Ans:
 $F_R = 497 \text{ N}$

2-5.

If the magnitude of the resultant force is to be 500 N, directed along the positive y axis, determine the magnitude of force **F** and its direction u .

SOLUTION

The parallelogram law of addition and the triangular rule are shown in Figs. *a* and *b*, respectively.

Applying the law of cosines to Fig. *b*,

$$F = \sqrt{500^2 + 700^2 - 2(500)(700) \cos 105^\circ}$$

$$= 959.78 \text{ N} = 960 \text{ N}$$

Applying the law of sines to Fig. *b*, and using this result, yields

$$\frac{\sin(90^\circ + u)}{700} = \frac{\sin 105^\circ}{959.78}$$

$$u = 45.2^\circ$$

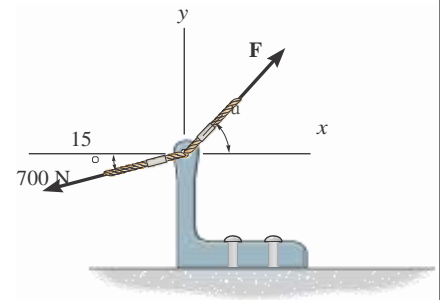

Ans.

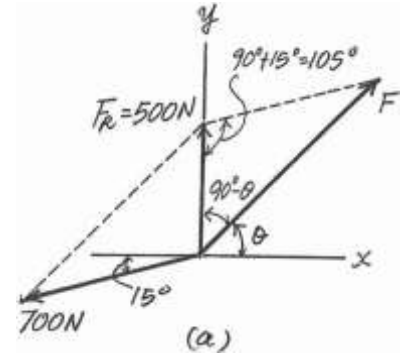

Ans.

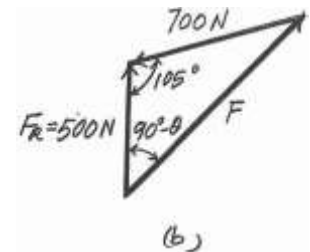

Ans:

$$F = 960 \text{ N}$$
$$u = 45.2$$

2-6. If $F_B = 2 \text{ kN}$ and the resultant force acts along the positive u axis, determine the magnitude of the resultant force and the angle u .

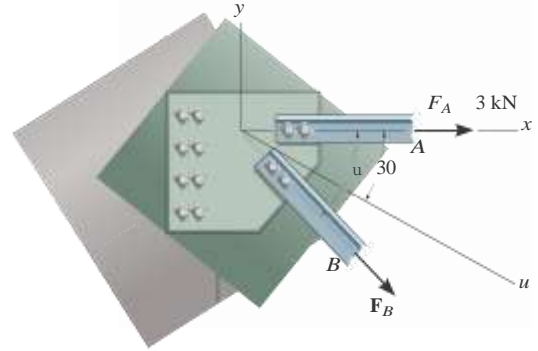

Solution

The parallelogram law of addition and the triangular rule are shown in Figs. *a* and *b*, respectively.

Applying the law of sines to Fig. *b*, yields

$$\frac{\sin f}{3} = \frac{\sin 30}{3} \quad f = 48.59$$

Thus,

$$u = 30 + f = 30 + 48.59 = 78.59 = 78.6 \quad \text{Ans.}$$

With the result $u = 78.59$, applying the law of sines to Fig. *b* again, yields

$$\frac{F_R}{\sin(180 - 78.59)} = \frac{2}{\sin 30} \quad F_R = 3.92 \text{ kN} \quad \text{Ans.}$$

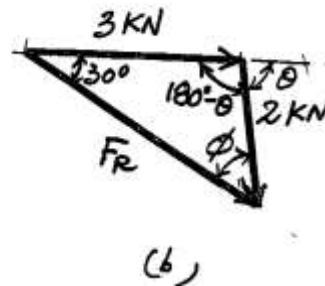
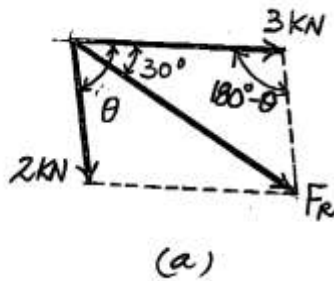

Ans:
78.6°
 $F_R = 3.92 \text{ kN}$

2-7. If the resultant force is required to act along the positive u axis and have a magnitude of 5 kN, determine the required magnitude of F_B and its direction u .

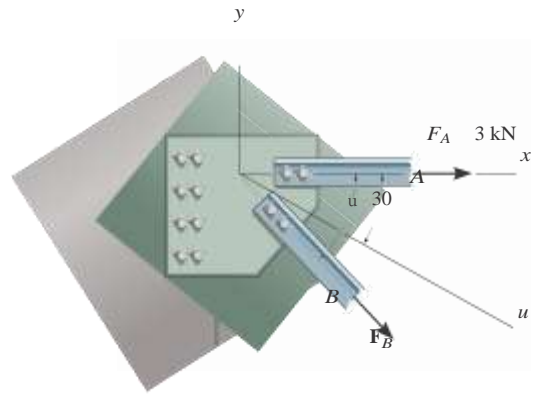

Solution

The parallelogram law of addition and the triangular rule are shown in Figs. *a* and *b*, respectively.

Applying the law of cosines to Fig. *b*,

$$F_B = \sqrt{2^2 + 5^2 - 2(2)(5) \cos 30}$$

$$= 2.832 \text{ kN} = 2.83 \text{ kN}$$

Ans.

Using this result and realizing that $\sin(180^\circ - u) = \sin u$, the application of the sine law to Fig. *b*, yields

$$\frac{\sin u}{5} = \frac{\sin 30}{2.832}$$

$$u = 62.0$$

Ans.

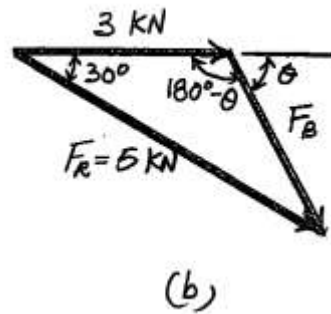
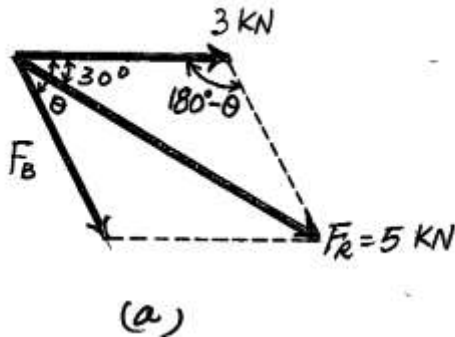

Ans:
2.83 kN
 $u = 62.0$

*2-8. Determine the magnitude of the resultant force $\mathbf{F}_R = \mathbf{F}_1 + \mathbf{F}_2$ and its direction, measured clockwise from the positive x axis.

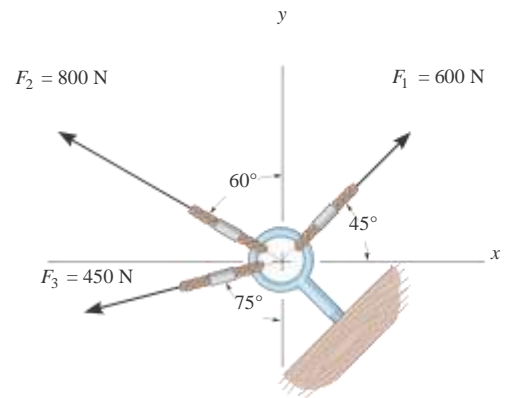

Solution

$$F_R = \sqrt{(600)^2 + (800)^2 - 2(600)(800)\cos 75} = 866.91 = 867 \text{ N}$$

Ans.

$$\frac{866.91}{\sin 75} = \frac{800}{\sin u}$$

$$\sin 75 = \sin u$$

$$u = 63.05$$

$$\mathbf{f} = 63.05 + 45 = 108$$

Ans.

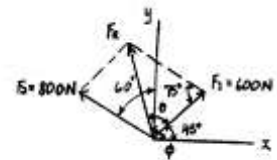

Ans:
u = 108

2-9.

Resolve F_1 into components along the u and v axes and determine the magnitudes of these components.

SOLUTION

Sine law:

$$\frac{F_{1v}}{\sin 30^\circ} = \frac{250}{\sin 105^\circ} \quad F_{1v} = 129 \text{ N}$$

$$\frac{F_{1u}}{\sin 45^\circ} = \frac{250}{\sin 105^\circ} \quad F_{1u} = 183 \text{ N}$$

Ans.

Ans.

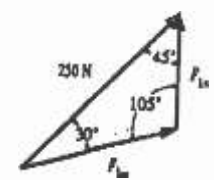
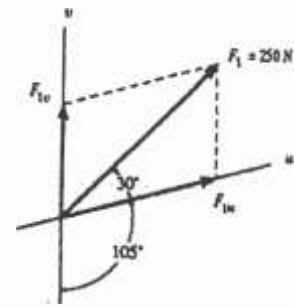
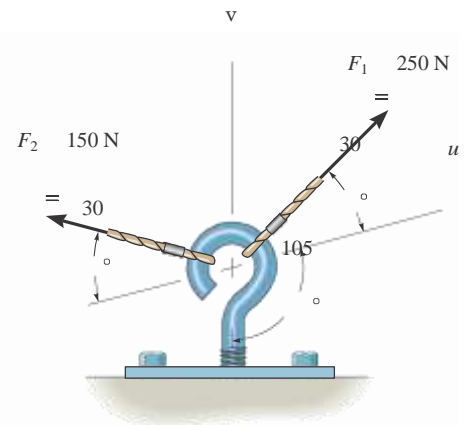

Ans:
 $F_{1v} = 129 \text{ N}$
 $F_{1u} = 183 \text{ N}$

2-10.

Resolve F_2 into components along the u and v axes and determine the magnitudes of these components.

SOLUTION

Sine law:

$$\frac{F_{2v}}{\sin 30^\circ} = \frac{150}{\sin 75^\circ} \quad F_{2v} = 77.6 \text{ N}$$

$$\frac{F_{2u}}{\sin 75^\circ} = \frac{150}{\sin 75^\circ} \quad F_{2u} = 150 \text{ N}$$

Ans.

Ans.

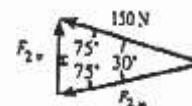
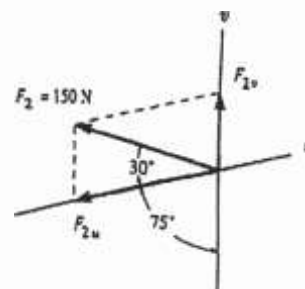
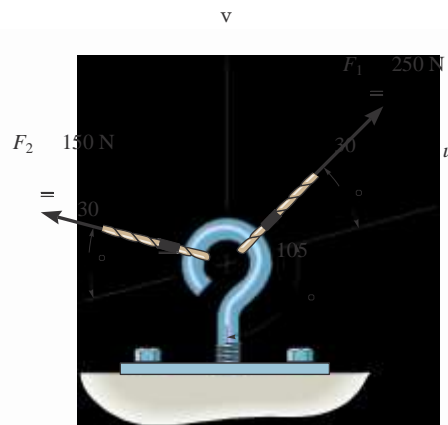

Ans:
 $F_{2v} = 77.6 \text{ N}$
 $F_{2u} = 150 \text{ N}$

2-11. The device is used for surgical replacement of the knee joint. If the force acting along the leg is 360 N, determine its components along the x and y_i axes.

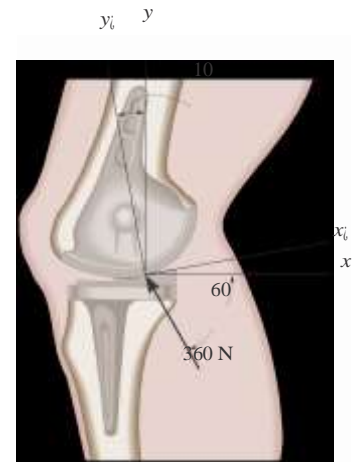

Solution

$$\frac{-F_x}{\sin 20} = \frac{360}{\sin 100}; \quad F_x = -125 \text{ N} \quad \text{Ans.}$$

$$\frac{F_y}{\sin 60} = \frac{360}{\sin 100}; \quad F_y = 317 \text{ N} \quad \text{Ans.}$$

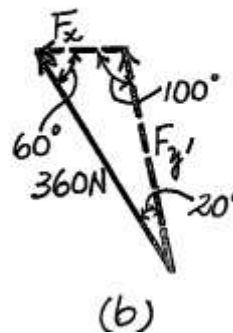
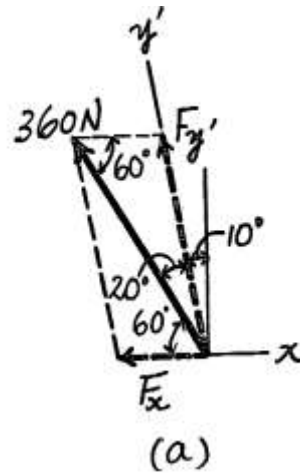

Ans:
 $F_x = -125 \text{ N}$
 $F_y = 317 \text{ N}$

*2-12. The device is used for surgical replacement of the knee joint. If the force acting along the leg is 360 N, determine its components along the x_i and y axes.

Solution

$$\frac{-F_x}{\sin 30} = \frac{360}{\sin 80}, \quad F_x = -183 \text{ N}$$

$$\frac{F_y}{\sin 70} = \frac{360}{\sin 80}, \quad F_y = 344 \text{ N}$$

Ans.

Ans.

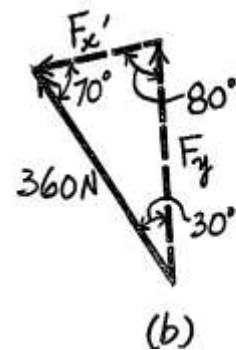
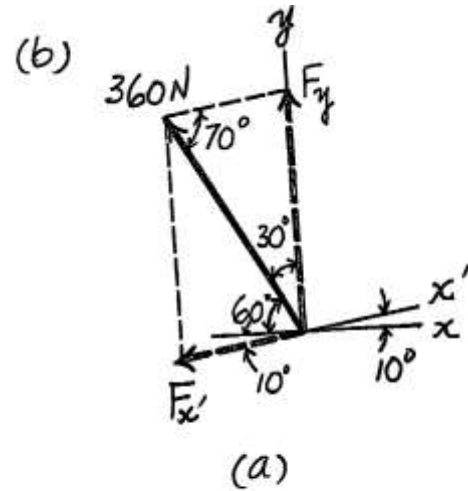
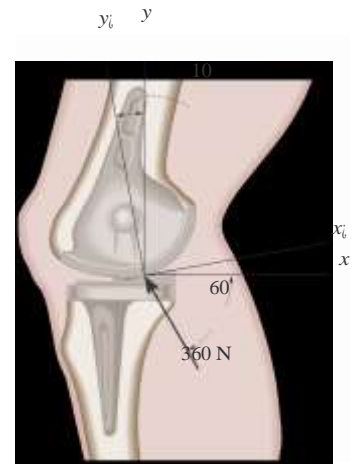

Ans:

$$F_x = -183 \text{ N}$$

$$F_y = 344 \text{ N}$$

2-13.

If the tension in the cable is 400 N, determine the magnitude and direction of the resultant force acting on the pulley. This angle defines the same angle of line AB on the tailboard block.

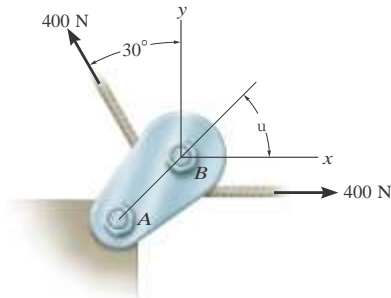

Solution

$$F_R = \sqrt{F_1^2 + F_2^2 - 2F_1F_2\cos 90^\circ}$$

$$\begin{aligned} \theta &= 30^\circ \\ F_R &= 400 \text{ N} \end{aligned}$$

$$\frac{\sin 90^\circ}{F_R} = \frac{\sin \theta}{F_1}$$

$$90^\circ = \arcsin \left(\frac{F_R}{F_1} \sin \theta \right)$$

$$60^\circ$$

Ans.

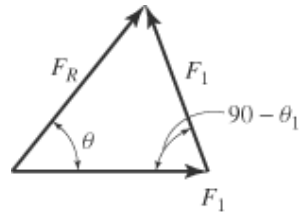
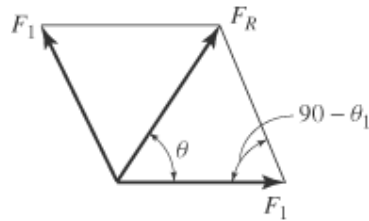

2-14. The truck is to be towed using two ropes. Determine the magnitude of forces F_A and F_B acting on each rope in order to develop a resultant force of 950 N directed along the positive x axis. Set $\alpha = 50^\circ$.

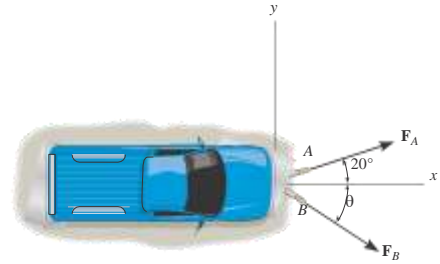

Solution

Parallelogram Law: The parallelogram law of addition is shown in Fig. (a).

Trigonometry: Using law of sines [Fig. (b)], we have

$$\frac{F_A}{\sin 50^\circ} = \frac{950}{\sin 110^\circ}$$

$$F_A = 774 \text{ N}$$

$$\frac{F_B}{\sin 20^\circ} = \frac{950}{\sin 110^\circ}$$

$$F_B = 346 \text{ N}$$

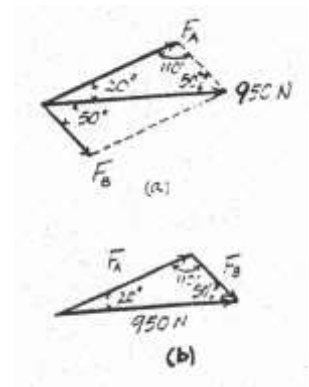

Ans.

Ans.

Ans:

$$F_A = 774 \text{ N}$$

$$F_B = 346 \text{ N}$$

2-15.

The plate is subjected to the two forces at A and B as shown. If $u = 60^\circ$, determine the magnitude of the resultant of these two forces and its direction measured clockwise from the horizontal.

SOLUTION

Parallelogram Law: The parallelogram law of addition is shown in Fig. a .

Trigonometry: Using law of cosines (Fig. b), we have

$$F_R = \sqrt{8^2 + 6^2 - 2(8)(6) \cos 100^\circ}$$

$$= 10.80 \text{ kN} = 10.8 \text{ kN}$$

The angle u can be determined using law of sines (Fig. b).

$$\frac{\sin u}{6} = \frac{\sin 100^\circ}{10.80}$$

$$\sin u = 0.5470$$

$$u = 33.16^\circ$$

Thus, the direction f of F_R measured from the x axis is

$$f = 33.16^\circ - 30^\circ = 3.16^\circ$$

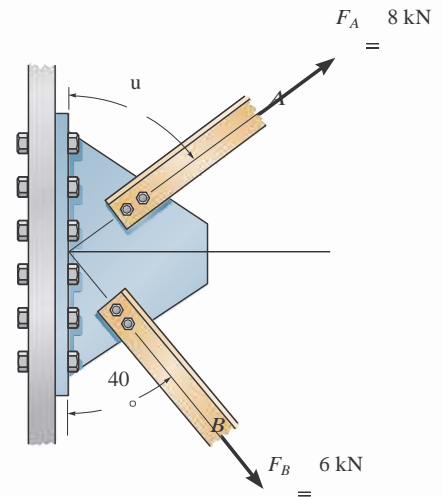

Ans.

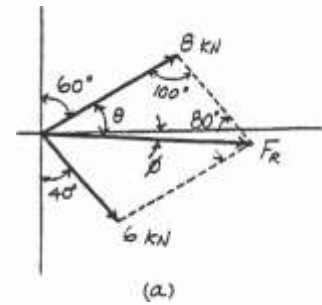

Ans.

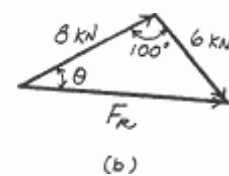

Ans:
 $F_R = 10.8 \text{ kN}$
 $f = 3.16$

***2-16.**

Determine the angle of u for connecting member A to the plate so that the resultant force of F_A and F_B is directed horizontally to the right. Also, what is the magnitude of the resultant force?

SOLUTION

Parallelogram Law: The parallelogram law of addition is shown in Fig. *a*.

Trigonometry: Using law of sines (Fig. *b*), we have

$$\frac{\sin(90^\circ - u)}{6} = \frac{\sin 50^\circ}{8}$$

$$\begin{aligned} \sin(90^\circ - u) &= 0.5745 \\ u &= 54.93^\circ = 54.9^\circ \end{aligned}$$

From the triangle, $\theta = 180^\circ - (90^\circ - 54.93^\circ) - 50^\circ = 94.93^\circ$. Thus, using law of cosines, the magnitude of F_R is

$$\begin{aligned} F_R &= \sqrt{8^2 + 6^2 - 2(8)(6) \cos 94.93^\circ} \\ &= 10.4 \text{ kN} \end{aligned}$$

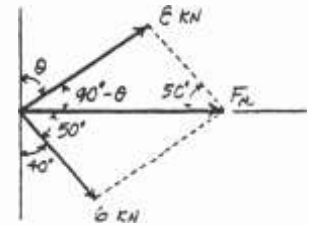
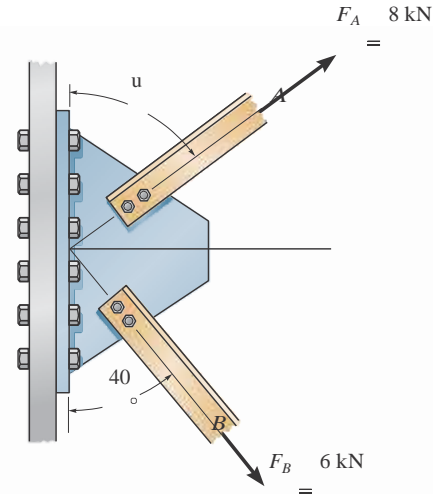

Ans.

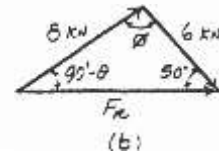

Ans.

Ans:
 $u = 54.9$
 $F_R = 10.4 \text{ kN}$

2-17.

Two forces act on the screw eye. If $F_1 = 400\text{ N}$ and $F_2 = 600\text{ N}$, determine the angle $u(0^\circ \dots u \dots 180^\circ)$ between them, so that the resultant force has a magnitude of $F_R = 800\text{ N}$.

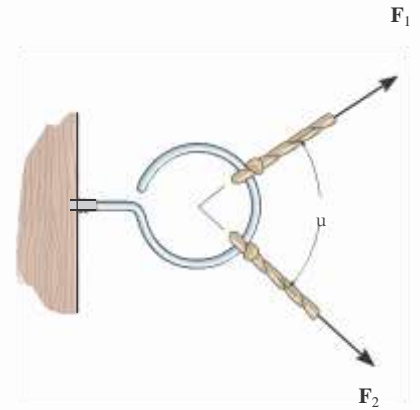

SOLUTION

The parallelogram law of addition and triangular rule are shown in Figs. *a* and *b*, respectively. Applying law of cosines to Fig. *b*,

$$800 = \sqrt{400^2 + 600^2 - 2(400)(600) \cos (180^\circ - u)}$$

$$800^2 = 400^2 + 600^2 - 480000 \cos (180^\circ - u)$$

$$\cos (180^\circ - u) = -0.25$$

$$180^\circ - u = 104.48$$

$$u = 75.52^\circ = 75.5^\circ$$

Ans.

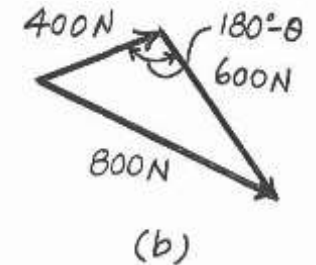
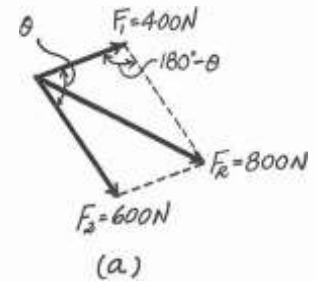

Ans:
 $u = 75.5$

2-18.

Two forces F_1 and F_2 act on the screw eye. If their lines of action are at an angle u apart and the magnitude of each force is $F_1 = F_2 = F$, determine the magnitude of the resultant force F_R and the angle between F_R and F_1 .

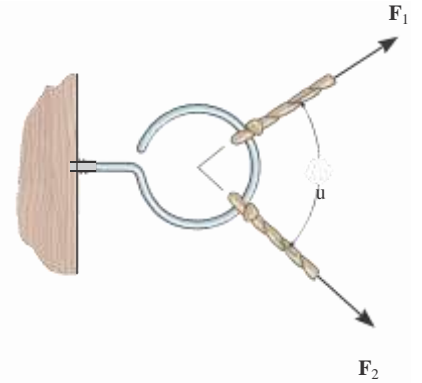

SOLUTION

$$\frac{F}{\sin f} = \frac{F}{\sin(u - f)}$$

$$\sin(u - f) = \sin f$$

$$u - f = f$$

$$f = \frac{u}{2}$$

$$F_R = \sqrt{(F)^2 + (F)^2 - 2(F)(F) \cos(180^\circ - u)}$$

Since $\cos(180^\circ - u) = -\cos u$

$$F_R = F \sqrt{2 + 2 \cos u}$$

Since $\cos \frac{u}{2} = \frac{1 + \cos u}{2}$

Then

$$F_R = 2F \cos \frac{u}{2}$$

Ans.

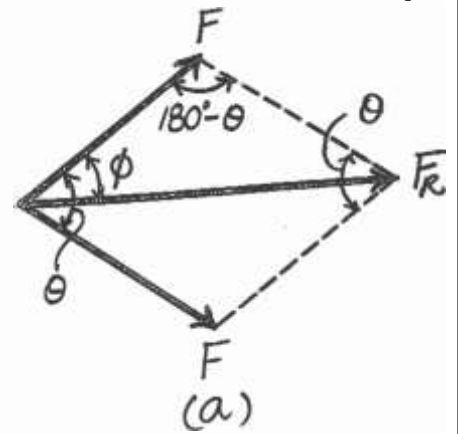

Ans.

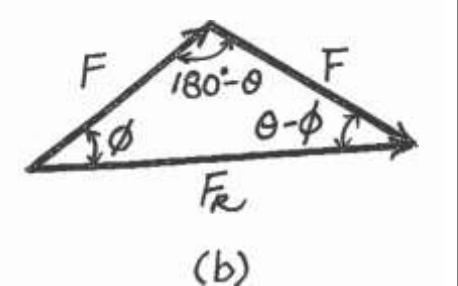

Ans:

$$f = \frac{u}{2}$$

$$F_R = 2F \cos \frac{u}{2}$$

2-19.

Determine the magnitude and direction of the resultant force, F_R measured counterclockwise from the positive x axis. Solve the problem by first finding the resultant $F = F_1 + F_2$ and then forming $F_R = F + F_3$.

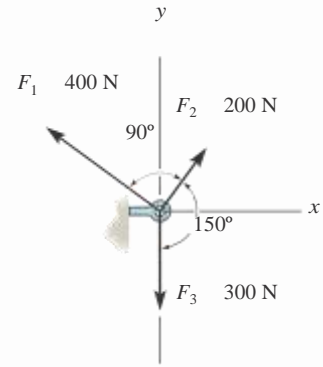

Solution

Parallelogram Law. The parallelogram law of addition for F_1 and F_2 and then their resultant F and F_3 are shown in Figs. *a* and *b*, respectively.

Trigonometry. Referring to Fig. *c*,

$$F = \sqrt{200^2 + 400^2} = 447.21\text{ N} \quad u = \tan^{-1} \frac{200}{400} = 26.57$$

$$\text{Thus } \phi = 90 - 30 - 26.57 = 33.43$$

Using these results to apply the law of cosines by referring to Fig. *d*,

$$F_R = \sqrt{300^2 + 447.21^2 - 2(300)(447.21) \cos 33.43} = 257.05\text{ N} = 257\text{ kN} \quad \text{Ans.}$$

Then, apply the law of sines,

$$\frac{\sin u}{300} = \frac{\sin 33.43}{257.05}; \quad u = 40.02$$

Thus, the direction ϕ of F_R measured counterclockwise from the positive x axis is

$$\phi = 90 + 33.43 + 40.02 = 163.45 = 163 \quad \text{Ans.}$$

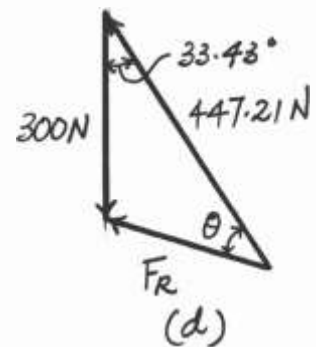
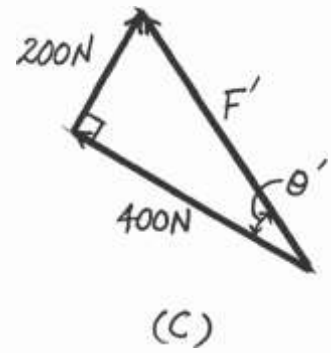
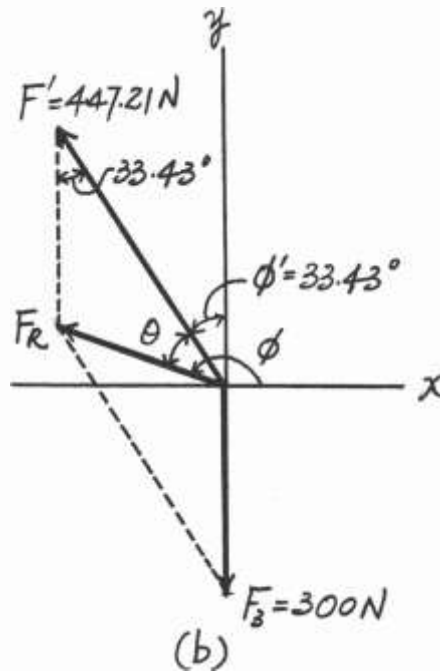
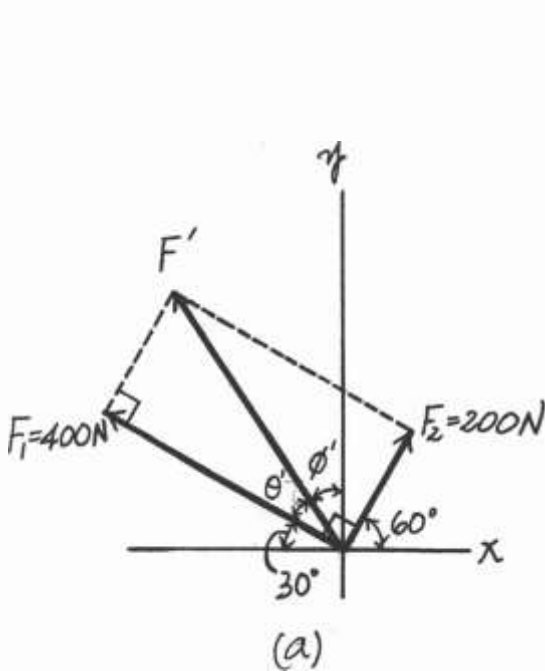

Ans:
 $F_R = 257\text{ N}$
 $\phi = 163$

*2-20. Determine the magnitude and direction of the resultant force, F_R measured counterclockwise from the positive x axis. Solve the problem by first finding the resultant $F \square = F_2 + F_3$ and then forming $F_R = F \square + F_1$.

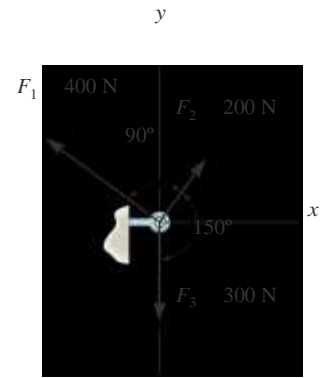

Solution

Parallelogram Law. The parallelogram law of addition for F_2 and F_3 and then their resultant F and F_1 are shown in Figs. *a* and *b*, respectively.

Trigonometry. Applying the law of cosines by referring to Fig. *c*,

$$F = \sqrt{200^2 + 300^2 - 2(200)(300)\cos 30} = 161.48 \text{ N} \quad \text{Ans.}$$

Using this result to apply the sines law, Fig. *c*,

$$\frac{\sin u}{200} = \frac{\sin 30}{161.48}; \quad u = 38.26$$

Using the results of F and u to apply the law of cosines by referring to Fig. *d*,

$$F_R = \sqrt{161.48^2 + 400^2 - 2(161.48)(400)\cos 21.74} = 257.05 \text{ N} = 257 \text{ N} \quad \text{Ans.}$$

Then, apply the sines law,

$$\frac{\sin u}{161.48} = \frac{\sin 21.74}{257.05}; \quad u = 13.45$$

Thus, the direction ϕ of F_R measured counterclockwise from the positive x axis is

$$\phi = 90 + 60 + 13.45 = 163.45 = 163 \quad \text{Ans.}$$

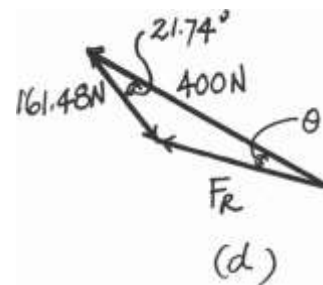
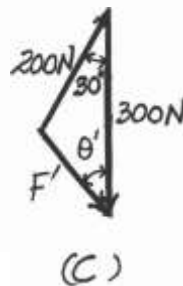
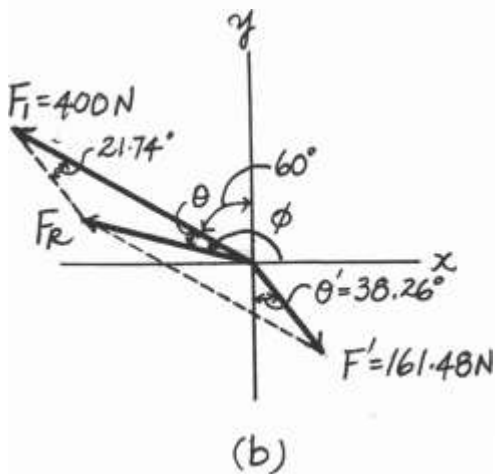
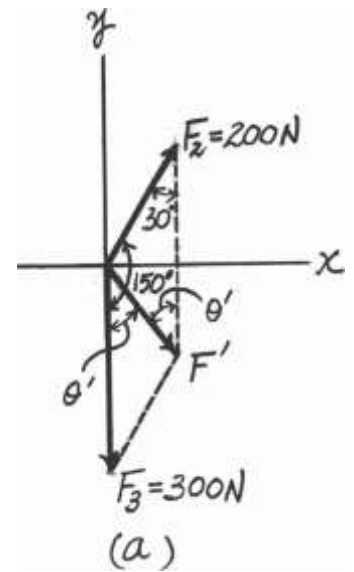

Ans:
 $\phi = 163$
 $F_R = 257 \text{ N}$

2-21. The log is being towed by two tractors *A* and *B*. Determine the magnitude of the two towing forces F_A and F_B if it is required that the resultant force have a magnitude $F_R = 10$ kN and be directed along the *x* axis. Set $\alpha = 15^\circ$.

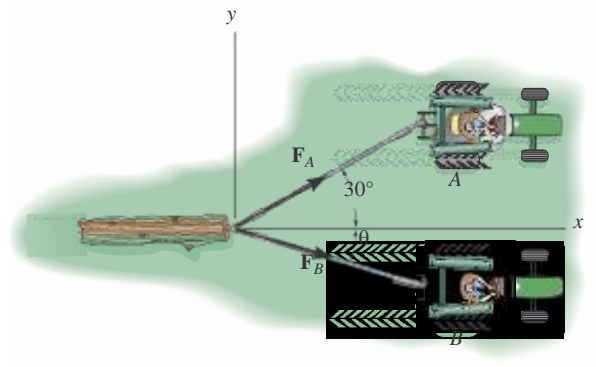

Solution

Parallelogram Law: The parallelogram law of addition is shown in Fig. (a).

Trigonometry: Using law of sines [Fig. (b)], we have

$$\frac{F_A}{\sin 15^\circ} = \frac{10}{\sin 135^\circ}$$

$$F_A = 3.66 \text{ kN}$$

Ans.

$$\frac{F_B}{\sin 30^\circ} = \frac{10}{\sin 135^\circ}$$

$$F_B = 7.07 \text{ kN}$$

Ans.

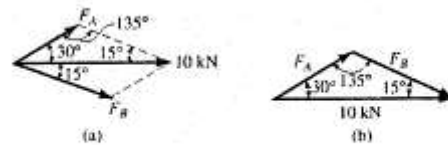

Ans:

$$F_A = 3.66 \text{ kN}$$

$$F_B = 7.07 \text{ kN}$$

2-22. If the resultant F_R of the two forces acting on the log is to be directed along the positive x axis and have a magnitude of 10 kN, determine the angle u of the cable, attached to B such that the force F_B in this cable is minimum. What is the magnitude of the force in each cable for this situation?

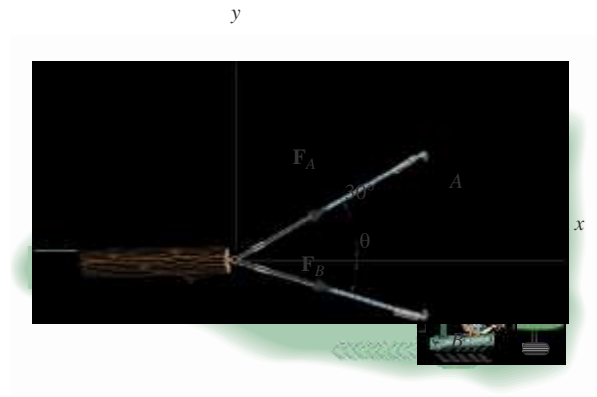

Solution

Parallelogram Law: In order to produce a *minimum* force, F_B , F_B has to act perpendicular to F_A . The parallelogram law of addition is shown in Fig. (a).

Trigonometry: Fig.(b).

$$F_B = 10 \sin 30 = 5.00 \text{ kN}$$

$$F_A = 10 \cos 30 = 8.66 \text{ kN}$$

The angle u is

$$u = 90 - 30 = 60.0$$

Ans.

Ans.

Ans.

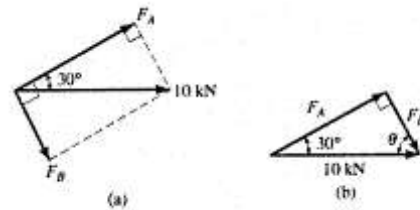

Ans:

$$F_B = 5.00 \text{ kN}$$

$$F_A = 8.66 \text{ kN}$$

$$u = 60.0$$

2-23.

Determine the magnitude and direction of the resultant $\mathbf{F}_R = \mathbf{F}_1 + \mathbf{F}_2 + \mathbf{F}_3$ of the three forces by first finding the resultant $\mathbf{F}_i = \mathbf{F}_1 + \mathbf{F}_2$ and then forming $\mathbf{F}_R = \mathbf{F}_i + \mathbf{F}_3$.

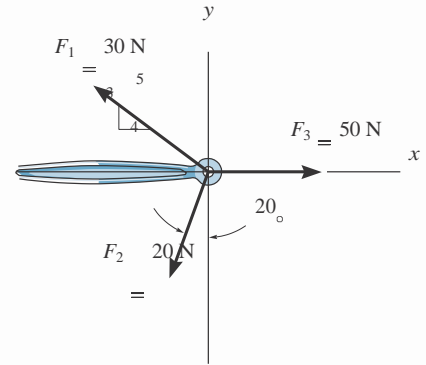

$$F_i = \sqrt{(20)^2 + (30)^2 - 2(20)(30) \cos 73.13^\circ} = 30.85 \text{ N}$$

$$\frac{30.85}{\sin 73.13^\circ} = \frac{30}{\sin (70^\circ - u)}; \quad u = 1.47^\circ$$

$$F_R = \sqrt{(30.85)^2 + (50)^2 - 2(30.85)(50) \cos 1.47^\circ} = 19.18 = 19.2 \text{ N}$$

$$\frac{19.18}{\sin 1.47^\circ} = \frac{30.85}{\sin u}; \quad u = 2.37^\circ \swarrow$$

Ans.

Ans.

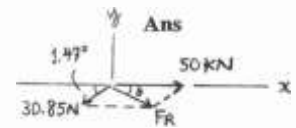
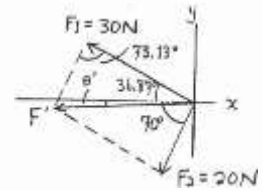

Ans:

$$F_R = 19.2 \text{ N}$$

$$u = 2.37^\circ \swarrow$$

***2-24.**

Determine the magnitude and direction of the resultant $\mathbf{F}_R = \mathbf{F}_1 + \mathbf{F}_2 + \mathbf{F}_3$ of the three forces by first finding the resultant $\mathbf{F}_i = \mathbf{F}_2 + \mathbf{F}_3$ and then forming $\mathbf{F}_R = \mathbf{F}_i + \mathbf{F}_1$.

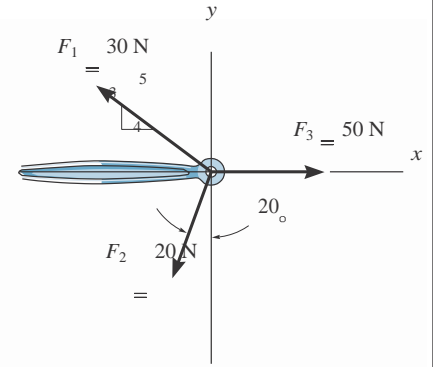

$$F_i = \sqrt{(20)^2 + (50)^2 - 2(20)(50) \cos 70^\circ} = 47.07\text{ N}$$

$$\frac{20}{\sin u} = \frac{47.07}{\sin 70^\circ}; \quad u = 23.53^\circ$$

$$F_R = \sqrt{(47.07)^2 + (30)^2 - 2(47.07)(30) \cos 13.34^\circ} = 19.18 = 19.2\text{ N} \quad \text{Ans.}$$

$$\frac{19.18}{\sin 13.34^\circ} = \frac{30}{\sin f}; \quad f = 21.15^\circ$$

$$u = 23.53^\circ - 21.15^\circ = 2.37^\circ \quad \text{Ans.}$$

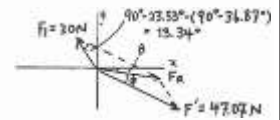
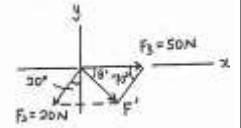

Ans:
 $F_R = 19.2\text{ N}$
 $u = 2.37^\circ$

2-25.

If the resultant force of the two tugboats is 3 kN, directed along the positive x axis, determine the required magnitude of force F_B and its direction u .

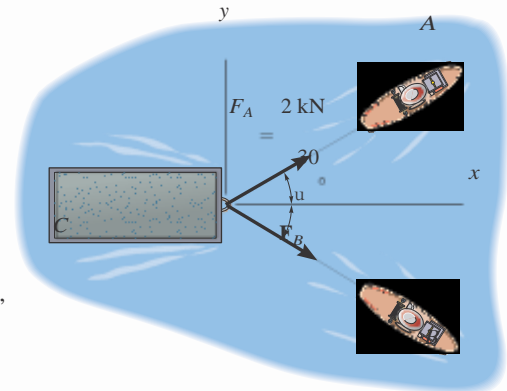

SOLUTION

The parallelogram law of addition and the triangular rule are shown in Figs. *a* and *b*, respectively.

Applying the law of cosines to Fig. *b*,

$$F_B = \sqrt{2^2 + 3^2 - 2(2)(3)\cos 30^\circ}$$

$$= 1.615 \text{ kN} = 1.61 \text{ kN}$$

Ans.

Using this result and applying the law of sines to Fig. *b*, yields

$$\frac{\sin u}{2} = \frac{\sin 30^\circ}{1.615} \quad u = 38.3^\circ$$

Ans.

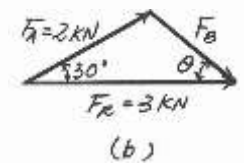
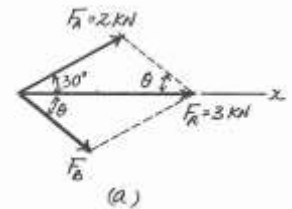

Ans:

$$F_B = 1.61 \text{ kN}$$

$$u = 38.3$$

2-26.

If $F_B = 3 \text{ kN}$ and $u = 45^\circ$, determine the magnitude of the resultant force of the two tugboats and its direction measured clockwise from the positive x axis.

SOLUTION

The parallelogram law of addition and the triangular rule are shown in Figs. *a* and *b*, respectively.

Applying the law of cosines to Fig. *b*,

$$F_R = \sqrt{2^2 + 3^2 - 2(2)(3) \cos 105^\circ}$$

$$= 4.013 \text{ kN} = 4.01 \text{ kN}$$

Ans.

Using this result and applying the law of sines to Fig. *b*, yields

$$\frac{\sin a}{3} = \frac{\sin 105^\circ}{4.013} \quad a = 46.22^\circ$$

Thus, the direction angle \mathbf{f} of F_R , measured clockwise from the positive x axis, is

$$\mathbf{f} = a - 30^\circ = 46.22^\circ - 30^\circ = 16.2^\circ$$

Ans.

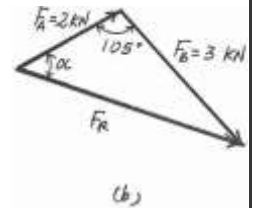
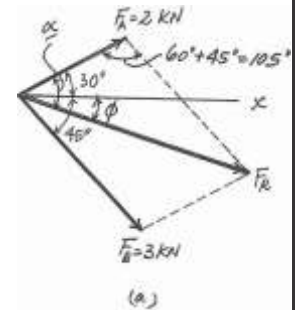
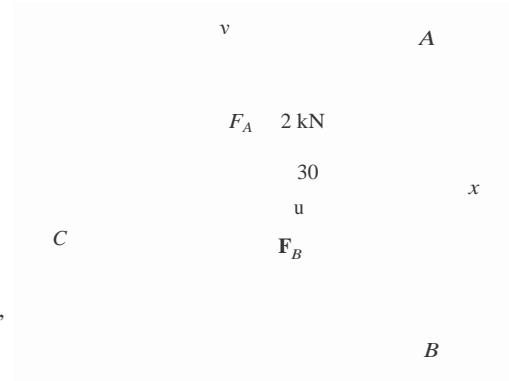

Ans:

$$F_R = 4.01 \text{ kN}$$

$$\mathbf{f} = 16.2$$

2-27.

If the resultant force of the two tugboats is required to be directed towards the positive x axis, and F_B is to be a minimum, determine the magnitude of F_R and F_B and the angle u .

SOLUTION

For F_B to be minimum, it has to be directed perpendicular to F_R . Thus,

$$u = 90^\circ$$

Ans.

The parallelogram law of addition and triangular rule are shown in Figs. *a* and *b*, respectively.

By applying simple trigonometry to Fig. *b*,

$$F_B = 2 \sin 30^\circ = 1 \text{ kN}$$

Ans.

$$F_R = 2 \cos 30^\circ = 1.73 \text{ kN}$$

Ans.

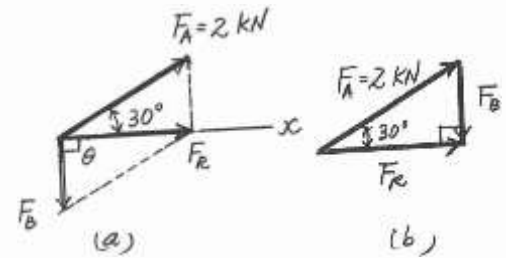
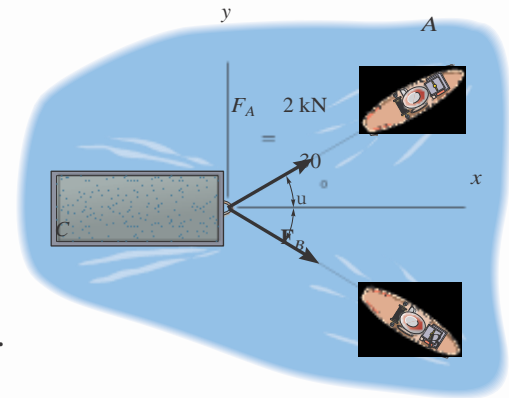

Ans:

$$u = 90$$

$$F_B = 1 \text{ kN}$$

$$F_R = 1.73 \text{ kN}$$

*2-28.

Determine the magnitude of force F so that the resultant F_R of the three forces is as small as possible. What is the minimum magnitude of F_R ?

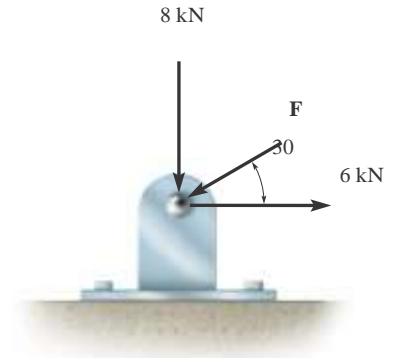

Solution

Parallelogram Law. The parallelogram laws of addition for 6 kN and 8 kN and then their resultant F' and F are shown in Figs. *a* and *b*, respectively. In order for F_R to be minimum, it must act perpendicular to F .

Trigonometry. Referring to Fig. *b*,

$$F' = \sqrt{6^2 + 8^2} = 10.0 \text{ kN} \quad \theta = \tan^{-1} \frac{8}{6} = 53.13^\circ$$

Referring to Figs. *c* and *d*,

$$F_R = 10.0 \sin 83.13^\circ = 9.928 \text{ kN} = 9.93 \text{ kN} \quad \text{Ans.}$$

$$F = 10.0 \cos 83.13^\circ = 1.196 \text{ kN} = 1.20 \text{ kN} \quad \text{Ans.}$$

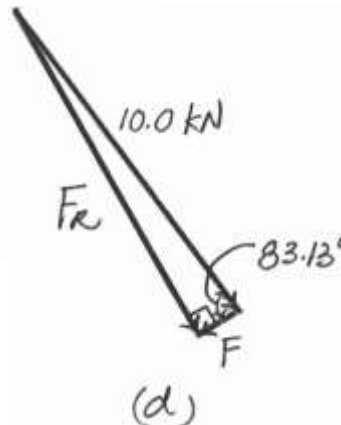
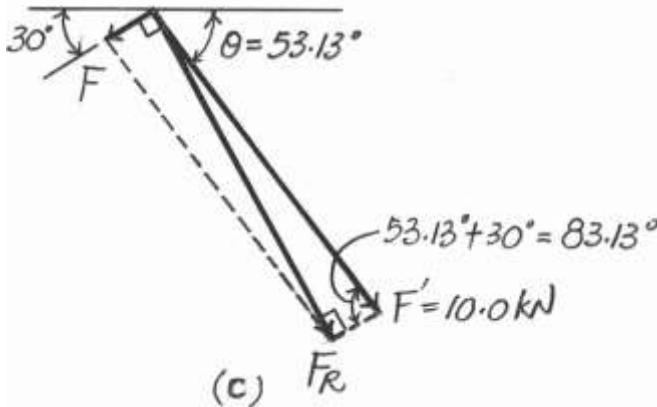
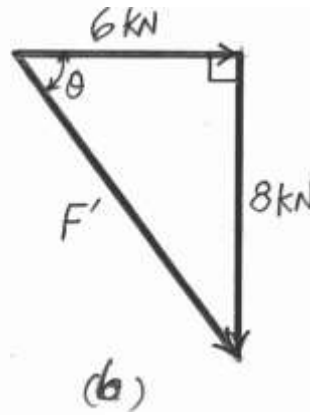
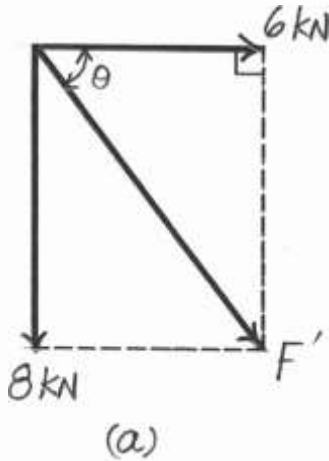

Ans:
 $F_R = 9.93 \text{ kN}$
 $F = 1.20 \text{ kN}$

2-29.

Determine the magnitude and direction u of \mathbf{F}_A so that the resultant force is directed along the positive x axis and has a magnitude of 1250 N.

SOLUTION

$$\downarrow + F_{R_x} = \Sigma F_x; \quad F_{R_x} = F_A \sin u + 800 \cos 30^\circ = 1250$$

$$+ \curvearrowright F_{R_y} = \Sigma F_y; \quad F_{R_y} = F_A \cos u - 800 \sin 30^\circ = 0$$

$$u = 54.3^\circ$$

$$F_A = 686 \text{ N}$$

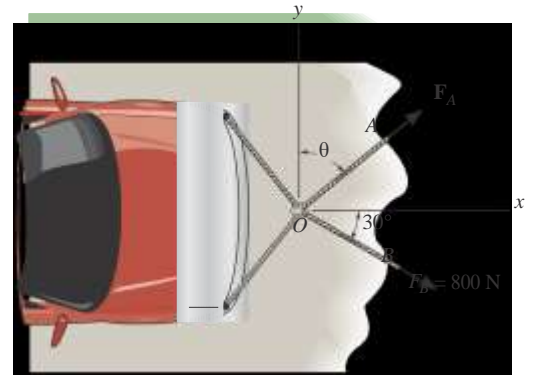

Ans.

Ans.

Ans:
 $u = 54.3$
 $F_A = 686 \text{ N}$

2-30.

Determine the magnitude and direction, measured counterclockwise from the positive x axis, of the resultant force acting on the ring at O , if $F_A = 750$ N and $\alpha = 45^\circ$.

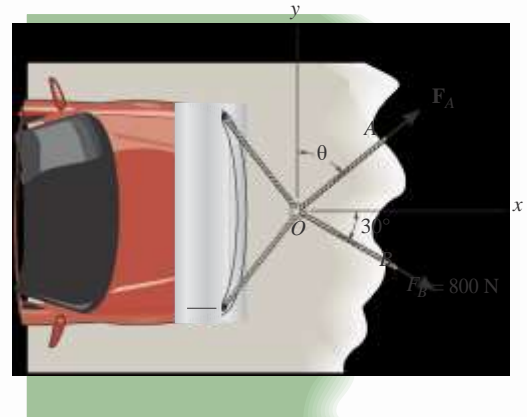

SOLUTION

Scalar Notation: Summing the force components algebraically, we have

$$\begin{aligned} \sum F_{R_x} = \sum F_x; \quad F_{R_x} &= 750 \sin 45^\circ + 800 \cos 30^\circ \\ &= 1223.15 \text{ N } \mathbf{S} \end{aligned}$$

$$\begin{aligned} + \sum F_{R_y} = \sum F_y; \quad F_{R_y} &= 750 \cos 45^\circ - 800 \sin 30^\circ \\ &= 130.33 \text{ N } \mathbf{c} \end{aligned}$$

The magnitude of the resultant force F_R is

$$\begin{aligned} F_R &= \sqrt{F_{R_x}^2 + F_{R_y}^2} \\ &= \sqrt{1223.15^2 + 130.33^2} = 1230 \text{ N} = 1.23 \text{ kN} \end{aligned}$$

The directional angle α measured counterclockwise from positive x axis is

$$\alpha = \tan^{-1} \frac{F_{R_y}}{F_{R_x}} = \tan^{-1} \frac{130.33}{1223.15} = 6.08^\circ$$

Ans.

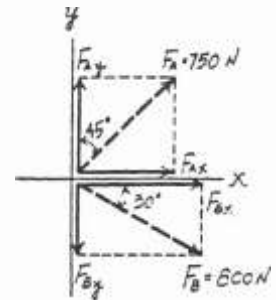

Ans.

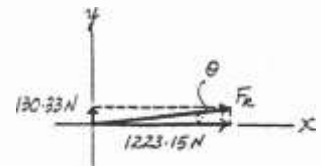

Ans:

$$\begin{aligned} F_R &= 1.23 \text{ kN} \\ \alpha &= 6.08 \end{aligned}$$

2-31.

Two forces act on the screw eye. If $F = 600$ N, determine the magnitude of the resultant force and the angle u if the resultant force is directed vertically upward.

SOLUTION

The parallelogram law of addition and triangular rule are shown in Figs. *a* and *b* respectively. Applying law of sines to Fig. *b*,

$$\frac{\sin u}{600} = \frac{\sin 30^\circ}{500}; \quad \sin u = 0.6 \quad u = 36.87^\circ = 36.9^\circ$$

Ans.

Using the result of u ,

$$f = 180^\circ - 30^\circ - 36.87^\circ = 113.13^\circ$$

Again, applying law of sines using the result of f ,

$$\frac{F_R}{\sin 113.13^\circ} = \frac{500}{\sin 30^\circ}; \quad F_R = 919.61 \text{ N} = 920 \text{ N}$$

Ans.

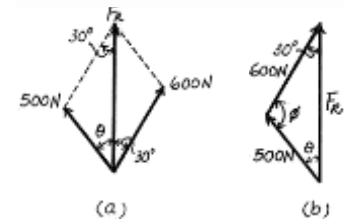
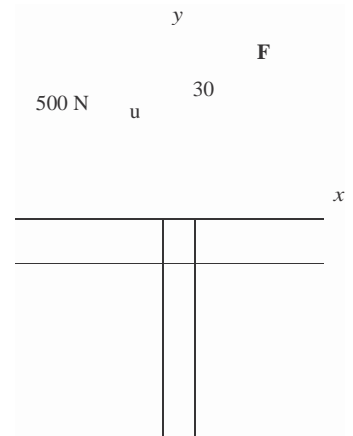

Ans:
 $u = 36.9$
 $F_R = 920 \text{ N}$

*2-32.

Resolve each force acting on the *gusset plate* into its *x* and *y* components, and express each force as a Cartesian vector.

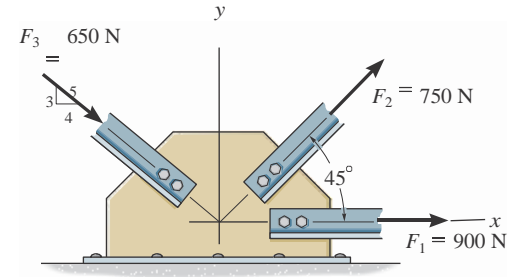

SOLUTION

$$\mathbf{F}_1 = \{900(+\mathbf{i})\} = \{900\mathbf{i}\} \text{ N}$$

Ans.

$$\begin{aligned} \mathbf{F}_2 &= \{750 \cos 45^\circ(+\mathbf{i}) + 750 \sin 45^\circ(+\mathbf{j})\} \text{ N} \\ &= \{530\mathbf{i} + 530\mathbf{j}\} \text{ N} \end{aligned}$$

Ans.

$$\begin{aligned} \mathbf{F}_3 &= e 650 a \frac{4}{5} b(+\mathbf{i}) + 650 a \frac{3}{5} b(-\mathbf{j}) f \text{ N} \\ &= \{520 \mathbf{i} - 390\mathbf{j}\} \text{ N} \end{aligned}$$

Ans.

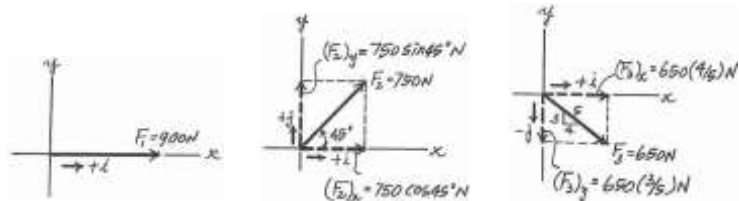

Ans:

$$\mathbf{F}_1 = 5900\mathbf{i}6 \text{ N}$$

$$\mathbf{F}_2 = 5530\mathbf{i} + 530\mathbf{j}6 \text{ N}$$

$$\mathbf{F}_3 = 5520\mathbf{i} - 390\mathbf{j}6 \text{ N}$$

2-33.

Determine the magnitude of the resultant force acting on the plate and its direction, measured counterclockwise from the positive x axis.

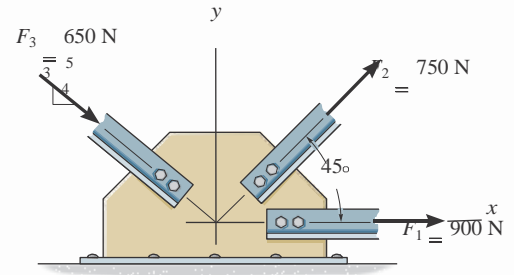

SOLUTION

Rectangular Components: By referring to Fig. a , the x and y components of F_1 , F_2 , and F_3 can be written as

$$\begin{aligned} (F_1)_x &= 900 \text{ N} & (F_1)_y &= 0 \\ (F_2)_x &= 750 \cos 45^\circ = 530.33 \text{ N} & (F_2)_y &= 750 \sin 45^\circ = 530.33 \text{ N} \\ (F_3)_x &= 650 a \frac{4}{5} b = 520 \text{ N} & (F_3)_y &= 650 a \frac{3}{5} b = 390 \text{ N} \end{aligned}$$

Resultant Force: Summing the force components algebraically along the x and y axes, we have

$$\begin{aligned} \oplus \circlearrowleft (F_R)_x &= \oplus F_x; & (F_R)_x &= 900 + 530.33 + 520 = 1950.33 \text{ N} \quad \ominus \\ + \circlearrowright (F_R)_y &= \ominus F_y; & (F_R)_y &= 530.33 - 390 = 140.33 \text{ N} \quad \oplus \end{aligned}$$

The magnitude of the resultant force F_R is _____

$$F_R = \sqrt{(F_R)_x^2 + (F_R)_y^2} = \sqrt{1950.33^2 + 140.33^2} = 1955 \text{ N} = 1.96 \text{ kN} \quad \text{Ans.}$$

The direction angle u of F_R , measured clockwise from the positive x axis, is

$$u = \tan^{-1} \frac{(F_R)_y}{(F_R)_x} = \tan^{-1} a \frac{140.33}{1950.33} b = 4.12^\circ \quad \text{Ans.}$$

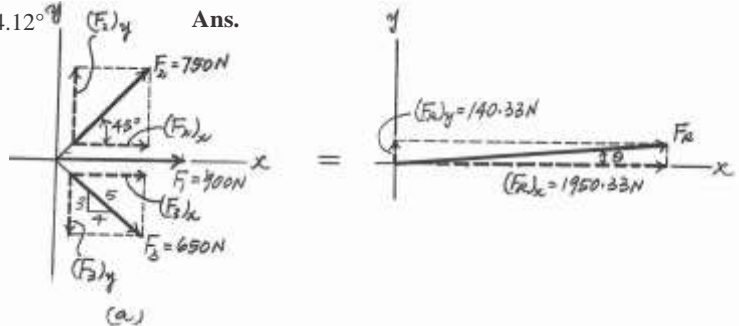

Ans:

$$F_R = 1.96 \text{ kN}$$
$$u = 4.12$$

2-34.

Resolve F_1 and F_2 into their x and y components.

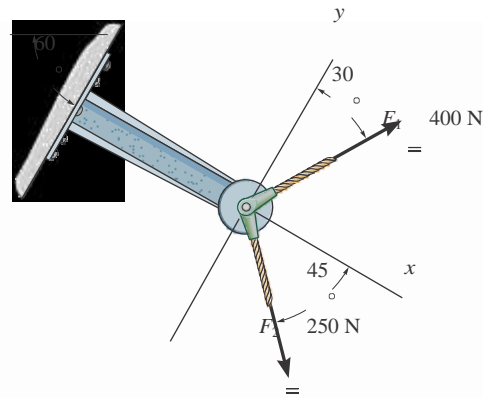

SOLUTION

$$\begin{aligned} \mathbf{F}_1 &= \{400 \sin 30^\circ(+\mathbf{i}) + 400 \cos 30^\circ(+\mathbf{j})\} \text{ N} \\ &= \{200\mathbf{i} + 346\mathbf{j}\} \text{ N} \end{aligned}$$

Ans.

$$\begin{aligned} \mathbf{F}_2 &= \{250 \cos 45^\circ(+\mathbf{i}) + 250 \sin 45^\circ(-\mathbf{j})\} \text{ N} \\ &= \{177\mathbf{i} - 177\mathbf{j}\} \text{ N} \end{aligned}$$

Ans.

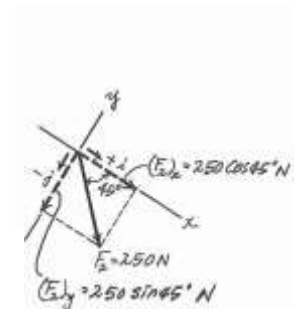
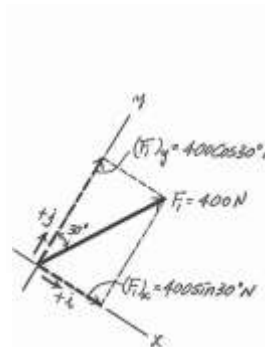

Ans:

$$\mathbf{F}_1 = 200\mathbf{i} + 346\mathbf{j} \text{ N}$$

$$\mathbf{F}_2 = 177\mathbf{i} - 177\mathbf{j} \text{ N}$$

2-35.

Determine the magnitude of the resultant force and its direction measured counterclockwise from the positive x axis.

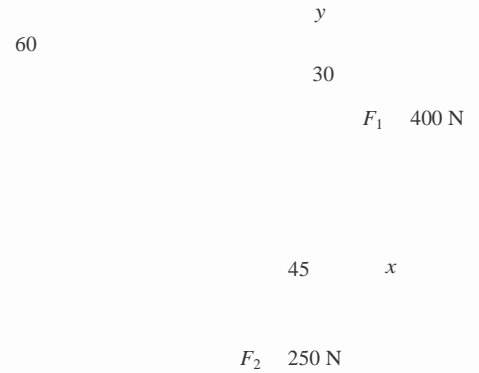

SOLUTION

Rectangular Components: By referring to Fig. a , the x and y components of \mathbf{F}_1 and \mathbf{F}_2 can be written as

$$(F_1)_x = 400 \sin 30^\circ = 200 \text{ N} \quad (F_1)_y = 400 \cos 30^\circ = 346.41 \text{ N}$$

$$(F_2)_x = 250 \cos 45^\circ = 176.78 \text{ N} \quad (F_2)_y = 250 \sin 45^\circ = 176.78 \text{ N}$$

Resultant Force: Summing the force components algebraically along the x and y axes, we have

$$\oplus \circledast (F_R)_x = \oplus F_x; \quad (F_R)_x = 200 + 176.78 = 376.78 \text{ N} \quad \text{Ans.}$$

$$\oplus \ominus \circledast (F_R)_y = \oplus F_y; \quad (F_R)_y = 346.41 - 176.78 = 169.63 \text{ N}$$

The magnitude of the resultant force \mathbf{F}_R is

$$F_R = \sqrt{(376.78)^2 + (169.63)^2} = 413 \text{ N}$$

The direction angle u of \mathbf{F}_R , Fig. b , measured counterclockwise from the positive axis, is

$$u = \tan^{-1} \frac{(F_R)_y}{(F_R)_x} = \tan^{-1} \frac{169.63}{376.78} = 24.2^\circ \quad \text{Ans.}$$

Ans:
 $F_R = 413 \text{ N}$
 $u = 24.2$

*2-36.

Determine the magnitude of the resultant force and its direction, measured counterclockwise from the positive x axis.

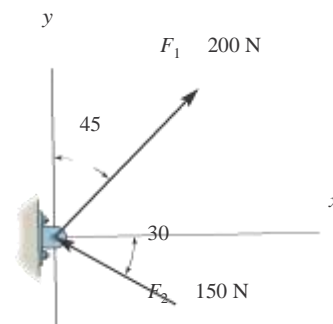

SOLUTION

$$+\circlearrowleft F_{Rx} = \circlearrowleft F_x; \quad F_{Rx} = -150 \cos 30^\circ + 200 \sin 45^\circ = 11.518 \text{ N}$$

$$+\circlearrowright F_{Ry} = \circlearrowright F_y; \quad F_{Ry} = 150 \sin 30^\circ + 200 \cos 45^\circ = 216.421 \text{ N}$$

$$F_R = \sqrt{(11.518)^2 + (216.421)^2} = 217 \text{ N}$$

$$u = \tan^{-1} \left(\frac{216.421}{11.518} \right) = 87.0^\circ$$

Ans.

Ans.

Ans:
 $F_R = 217 \text{ N}$
 $u = 87.0$

2-37.

Determine the magnitude of the resultant force and its direction, measured clockwise from the positive x axis.

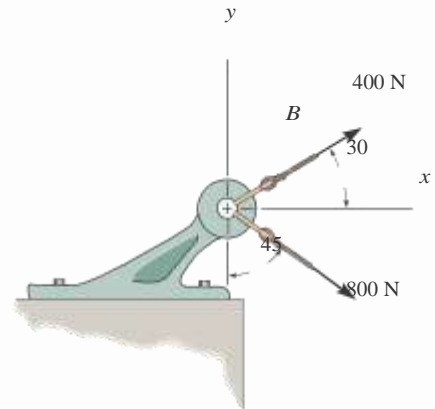

Solution

Scalar Notation. Summing the force components along x and y axes by referring to Fig. *a*,

$$\sum (F_R)_x = F_x; (F_R)_x = 400 \cos 30^\circ + 800 \sin 45^\circ = 912.10 \text{ N } \mathbf{S}$$

$$+\circlearrowleft (F_R)_y = F_y; (F_R)_y = 400 \sin 30^\circ - 800 \cos 45^\circ = -365.69 \text{ N} = 365.69 \text{ NT}$$

Referring to Fig. *b*, the magnitude of the resultant force is

$$F_R = \sqrt{(F_R)_x^2 + (F_R)_y^2} = \sqrt{912.10^2 + 365.69^2} = 982.67 \text{ N} = 983 \text{ N} \quad \mathbf{Ans.}$$

And its directional angle u measured clockwise from the positive x axis is

$$u = \tan^{-1} \frac{(F_R)_y}{(F_R)_x} = \tan^{-1} \frac{365.69}{912.10} = 21.84^\circ = 21.8^\circ \quad \mathbf{Ans.}$$

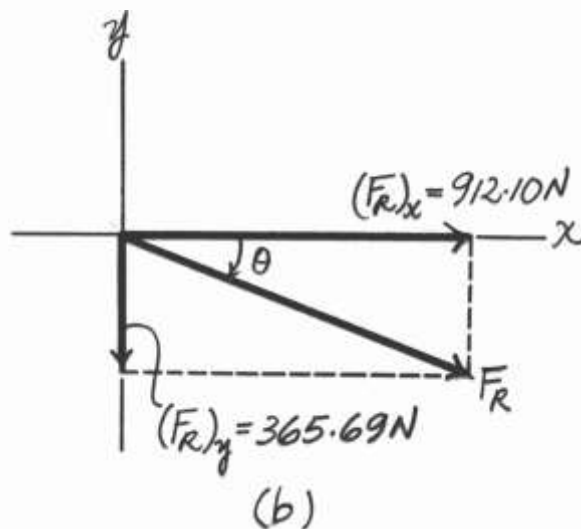
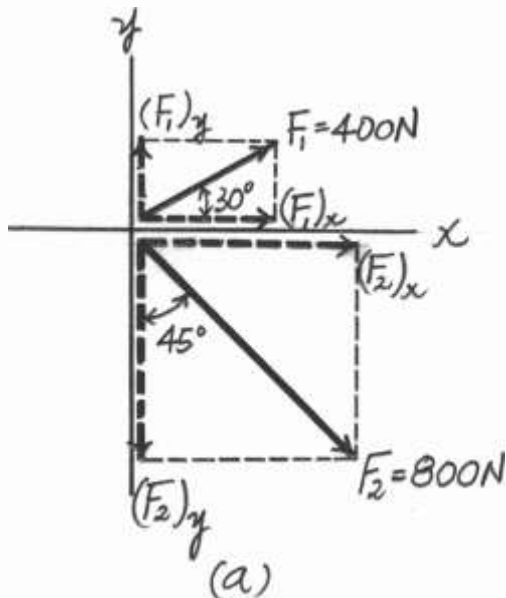

Ans:
 $F_R = 983 \text{ N}$
 $u = 21.8$

2-38.

Determine the magnitude of the resultant force and its direction, measured clockwise from the positive x axis.

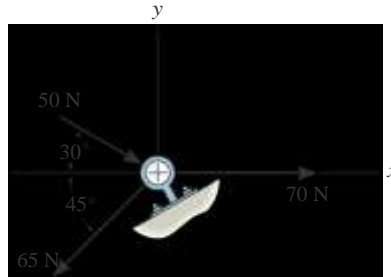

Solution

Given:

$$F_1 = 70 \text{ N}$$

$$F_2 = 50 \text{ N}$$

$$F_3 = 65 \text{ N}$$

$$30$$

$$45$$

$$F_{Rx} = F_x; \quad F_{RX} = F_1 + F_2 \cos \quad F_3 \cos$$

$$F_{Ry} = F_y; \quad F_{RY} = F_2 \sin \quad F_3 \sin$$

$$F_R = \sqrt{F_{RX}^2 + F_{RY}^2}$$

$$\text{atan} \frac{|F_{RY}|}{|F_{RX}|}$$

$$F_R = 97.8 \text{ N}$$

Ans.

$$46.5$$

Ans.

Ans:
 $F_R = 97.8 \text{ N}$
 $\alpha = 46.5$

2-39.

Express \mathbf{F}_1 , \mathbf{F}_2 , and \mathbf{F}_3 as Cartesian vectors.

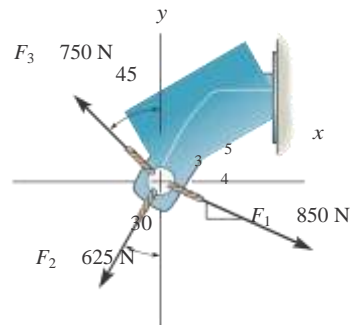

SOLUTION

$$\mathbf{F}_1 = \frac{4}{5}(850) \mathbf{i} - \frac{3}{5}(850) \mathbf{j}$$

$$= \{680 \mathbf{i} - 510 \mathbf{j}\} \text{ N}$$

Ans.

$$\mathbf{F}_2 = -625 \sin 30^\circ \mathbf{i} - 625 \cos 30^\circ \mathbf{j}$$

$$= \{-312 \mathbf{i} - 541 \mathbf{j}\} \text{ N}$$

Ans.

$$\mathbf{F}_3 = -750 \sin 45^\circ \mathbf{i} + 750 \cos 45^\circ \mathbf{j}$$

$$= \{-530 \mathbf{i} + 530 \mathbf{j}\} \text{ N}$$

Ans.

Ans:
 $\mathbf{F}_1 = \{680\mathbf{i} - 510\mathbf{j}\} \text{ N}$
 $\mathbf{F}_2 = \{-312\mathbf{i} - 541\mathbf{j}\} \text{ N}$
 $\mathbf{F}_3 = \{-530\mathbf{i} + 530\mathbf{j}\} \text{ N}$

*2-40.

Determine the magnitude of the resultant force and its direction measured counterclockwise from the positive x axis.

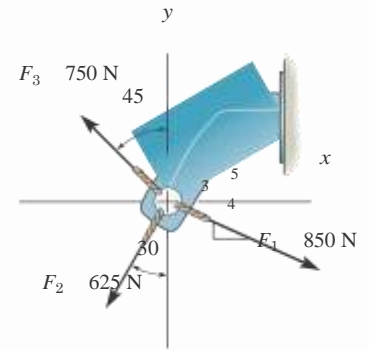

SOLUTION

$$\sum F_{Rx} = \sum F_x ; \quad F_{Rx} = \frac{4}{5}(850) - 625 \sin 30^\circ - 750 \sin 45^\circ = -162.83 \text{ N}$$

$$+ \sum F_{Ry} = \sum F_y ; \quad F_{Ry} = -\frac{3}{5}(850) - 625 \cos 30^\circ + 750 \cos 45^\circ = -520.94 \text{ N}$$

$$F_R = \sqrt{(-162.83)^2 + (-520.94)^2} = 546 \text{ N} \quad \text{Ans.}$$

$$\phi = \tan^{-1} \frac{520.94}{162.83} = 72.64^\circ$$

$$u = 180^\circ + 72.64^\circ = 253^\circ \quad \text{Ans.}$$

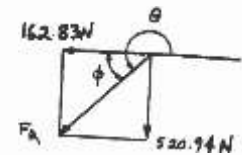

Ans:
 $F_R = 546 \text{ N}$
 $u = 253$

2-41.

Determine the magnitude and direction u of the resultant force F_R . Express the result in terms of the magnitudes of the components F_1 and F_2 and the angle f .

SOLUTION

$$F_R^2 = F_1^2 + F_2^2 - 2F_1F_2 \cos (180^\circ - f)$$

Since $\cos (180^\circ - f) = -\cos f$,

$$F_R = \sqrt{F_1^2 + F_2^2 + 2F_1F_2 \cos f}$$

From the figure,

$$\tan u = \frac{F_1 \sin f}{F_2 + F_1 \cos f}$$

$$u = \tan^{-1} \left(\frac{F_1 \sin f}{F_2 + F_1 \cos f} \right)$$

Ans.

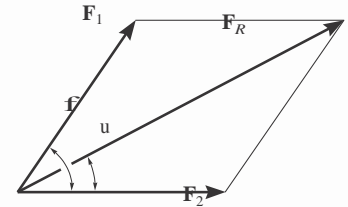

Ans.

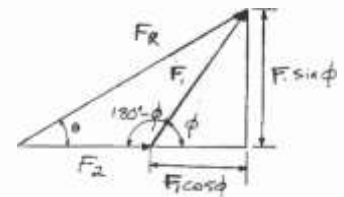

Ans:

$$F_R = \sqrt{F_1^2 + F_2^2 + 2F_1F_2 \cos f}$$

$$u = \tan^{-1} a \frac{F_1 \sin f}{F_2 + F_1 \cos f} b$$

2-42.

Determine the magnitude of the resultant force and its direction, measured counterclockwise from the positive x axis.

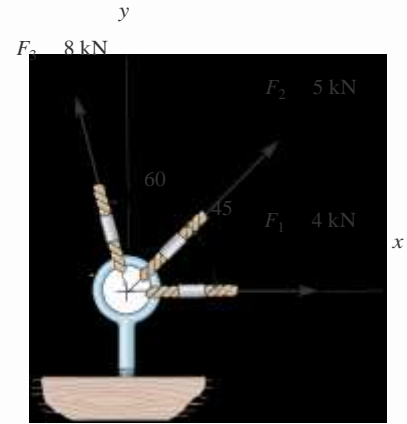

Solution

Scalar Notation. Summing the force components along x and y axes algebraically by referring to Fig. a ,

$$\sum (F_R)_x = F_x; \quad (F_R)_x = 4 + 5 \cos 45^\circ - 8 \sin 15^\circ = 5.465 \text{ kN } S$$

$$+\circlearrowleft (F_R)_y = F_y; \quad (F_R)_y = 5 \sin 45^\circ + 8 \cos 15^\circ = 11.263 \text{ kN } c$$

By referring to Fig. b , the magnitude of the resultant force F_R is

$$F_R = \sqrt{(F_R)_x^2 + (F_R)_y^2} = \sqrt{5.465^2 + 11.263^2} = 12.52 \text{ kN} = 12.5 \text{ kN} \quad \text{Ans.}$$

And the directional angle u of F_R measured counterclockwise from the positive x axis is

$$u = \tan^{-1} \frac{(F_R)_y}{(F_R)_x} = \tan^{-1} \frac{11.263}{5.465} = 64.12^\circ = 64.1^\circ$$

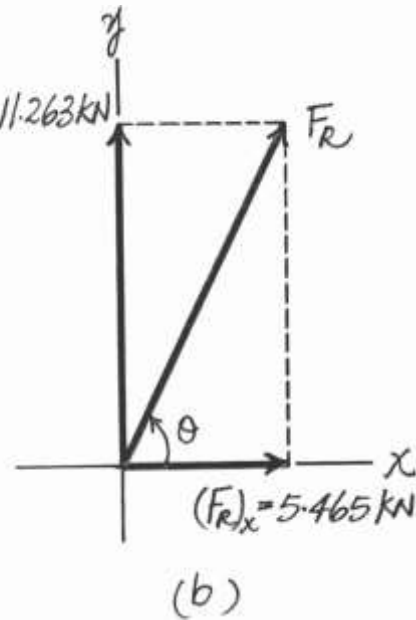
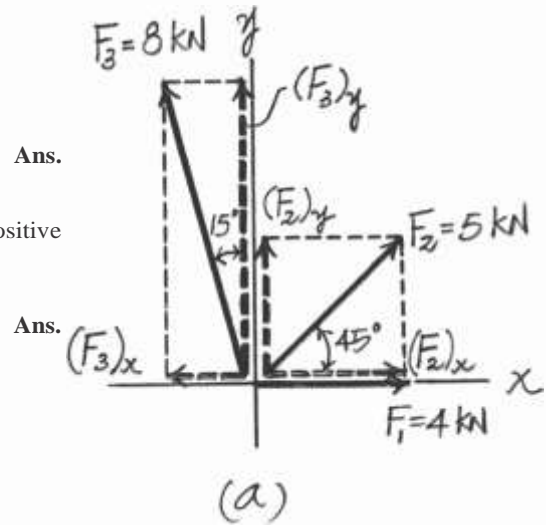

Ans:

$$F_R = 12.5 \text{ kN}$$

$$u = 64.1^\circ$$

2-43.

Determine the x and y components of F_1 and F_2 .

SOLUTION

$$F_{1x} = 200 \sin 45^\circ = 141 \text{ N}$$

$$F_{1y} = 200 \cos 45^\circ = 141 \text{ N}$$

$$F_{2x} = -150 \cos 30^\circ = -130 \text{ N}$$

$$F_{2y} = 150 \sin 30^\circ = 75 \text{ N}$$

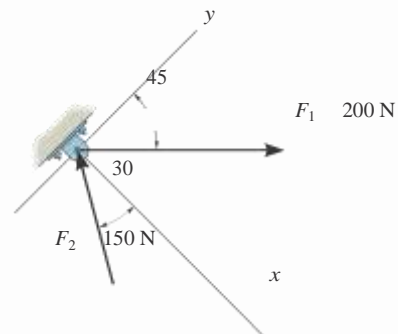

Ans.

Ans.

Ans.

Ans.

Ans:

$$F_{1x} = 141 \text{ N}$$

$$F_{1y} = 141 \text{ N}$$

$$F_{2x} = -130 \text{ N}$$

$$F_{2y} = 75 \text{ N}$$

*2-44.

Determine the magnitude of the resultant force and its direction, measured counterclockwise from the positive x axis.

SOLUTION

$$+R F_{Rx} = \odot F_x; \quad F_{Rx} = -150 \cos 30^\circ + 200 \sin 45^\circ = 11.518 \text{ N}$$

$$Q + F_{Ry} = \odot F_y; \quad F_{Ry} = 150 \sin 30^\circ + 200 \cos 45^\circ = 216.421 \text{ N}$$

$$F_R = \sqrt{(11.518)^2 + (216.421)^2} = 217 \text{ N}$$

$$u = \tan^{-1} \left(\frac{216.421}{11.518} \right) = 87.0^\circ$$

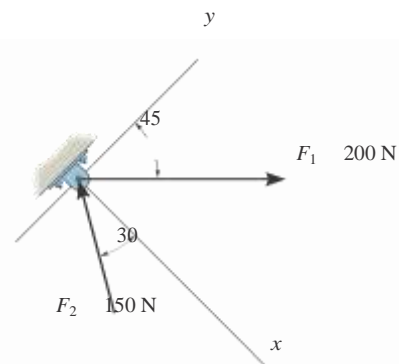

Ans.

Ans.

Ans:
 $F_R = 217 \text{ N}$
 $u = 87.0^\circ$

2-45.

Express each of the three forces acting on the support in Cartesian vector form and determine the magnitude of the resultant force and its direction, measured clockwise from positive x axis.

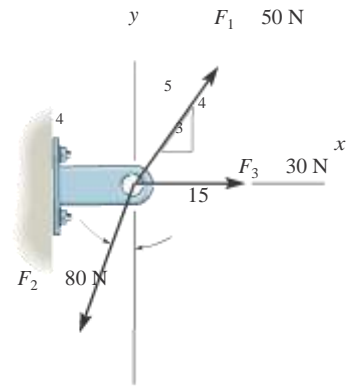

Solution

Cartesian Notation. Referring to Fig. *a*,

$$\mathbf{F}_1 = (F_1)_x \mathbf{i} + (F_1)_y \mathbf{j} = 50 a_{5/3} \mathbf{i} + 50 a_{4/5} \mathbf{j} = \{30 \mathbf{i} + 40 \mathbf{j}\} \text{ N} \quad \text{Ans.}$$

$$\begin{aligned} \mathbf{F}_2 &= -(F_2)_x \mathbf{i} - (F_2)_y \mathbf{j} = -80 \sin 15^\circ \mathbf{i} - 80 \cos 15^\circ \mathbf{j} \\ &= \{-20.71 \mathbf{i} - 77.27 \mathbf{j}\} \text{ N} \\ &= \{-20.7 \mathbf{i} - 77.3 \mathbf{j}\} \text{ N} \end{aligned}$$

$$\mathbf{F}_3 = (F_3)_x \mathbf{i} = \{30 \mathbf{i}\}$$

Thus, the resultant force is

$$\begin{aligned} \mathbf{F}_R &= \mathbf{F}_1 + \mathbf{F}_2 + \mathbf{F}_3 \\ &= (30 \mathbf{i} + 40 \mathbf{j}) + (-20.71 \mathbf{i} - 77.27 \mathbf{j}) + 30 \mathbf{i} \\ &= \{39.29 \mathbf{i} - 37.27 \mathbf{j}\} \text{ N} \end{aligned}$$

Referring to Fig. *b*, the magnitude of \mathbf{F}_R is

$$F_R = \sqrt{39.29^2 + 37.27^2} = 54.16 \text{ N} = 54.2 \text{ N}$$

And its directional angle u measured clockwise from the positive x axis is

$$u = \tan^{-1} a_{37.27/39.29} b = 43.49^\circ = 43.5^\circ$$

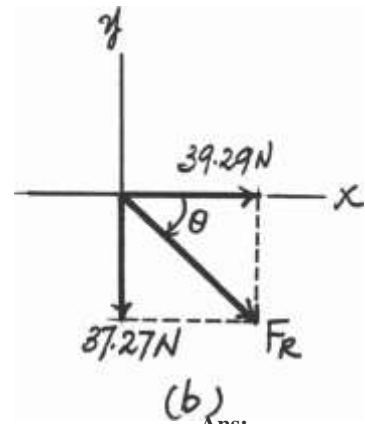
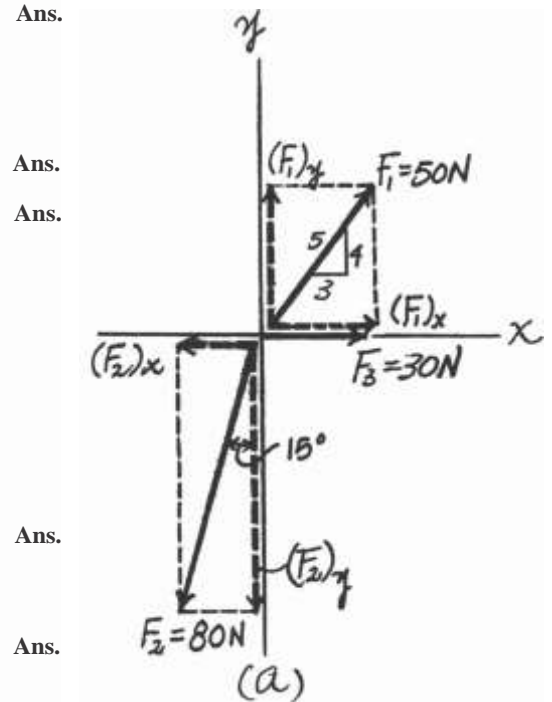

Ans:

$$\mathbf{F}_1 = \{30 \mathbf{i} + 40 \mathbf{j}\} \text{ N}$$

$$\mathbf{F}_2 = \{-20.7 \mathbf{i} - 77.3 \mathbf{j}\} \text{ N}$$

$$\mathbf{F}_3 = \{30 \mathbf{i}\}$$

$$F_R = 54.2 \text{ N}$$

$$u = 43.5^\circ$$

2-46.

Determine the x and y components of each force acting on the gusset plate of a bridge truss. Show that the resultant force is zero.

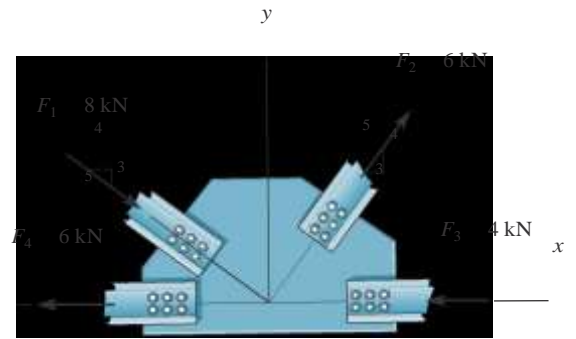

Solution

Scalar Notation. Referring to Fig. *a*, the x and y components of each forces are

$$(F_1)_x = 8 a \frac{4}{5} b = 6.40 \text{ kN } \mathbf{S} \quad \text{Ans.}$$

$$(F_1)_y = 8 a \frac{3}{5} b = 4.80 \text{ kN } \mathbf{T} \quad \text{Ans.}$$

$$(F_2)_x = 6 a \frac{3}{5} b = 3.60 \text{ kN } \mathbf{S} \quad \text{Ans.}$$

$$(F_2)_y = 6 a \frac{4}{5} b = 4.80 \text{ kN } \mathbf{c} \quad \text{Ans.}$$

$$(F_3)_x = 4 \text{ kN } \mathbf{d} \quad \text{Ans.}$$

$$(F_3)_y = 0 \quad \text{Ans.}$$

$$(F_4)_x = 6 \text{ kN } \mathbf{d} \quad \text{Ans.}$$

$$(F_4)_y = 0 \quad \text{Ans.}$$

Summing these force components along x and y axes algebraically,

$$\sum (F_R)_x = F_x; \quad (F_R)_x = 6.40 + 3.60 - 4 - 6 = 0$$

$$+ \sum (F_R)_y = F_y; \quad (F_R)_y = 4.80 - 4.80 = 0$$

Thus,

$$F_R = \sqrt{(F_R)_x^2 + (F_R)_y^2} = \sqrt{0^2 + 0^2} = 0 \quad \text{(Q.E.D)}$$

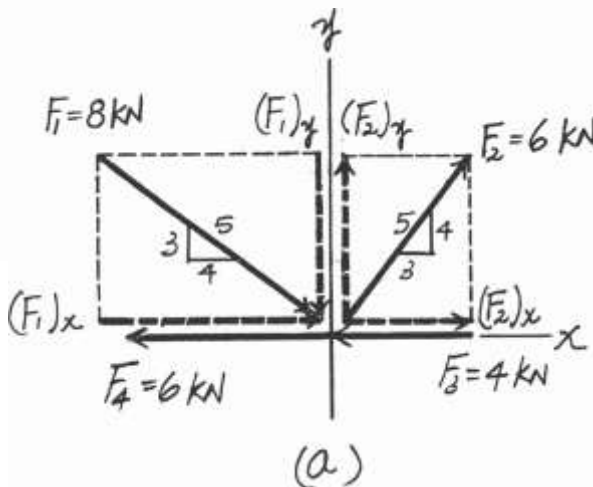

Ans:

$$(F_1)_x = 6.40 \text{ kN } \mathbf{S}$$

$$(F_1)_y = 4.80 \text{ kN } \mathbf{T}$$

$$(F_2)_x = 3.60 \text{ kN } \mathbf{S}$$

$$(F_2)_y = 4.80 \text{ kN } \mathbf{c}$$

$$(F_3)_x = 4 \text{ kN } \mathbf{d}$$

$$(F_3)_y = 0$$

$$(F_4)_x = 6 \text{ kN } \mathbf{d}$$

$$(F_4)_y = 0$$

2-47.

Express \mathbf{F}_1 , \mathbf{F}_2 , and \mathbf{F}_3 as Cartesian vectors.

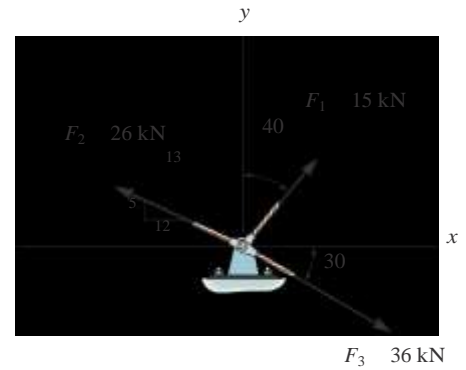

Solution

$$\mathbf{F}_1 = \{15 \sin 40 \mathbf{i} + 15 \cos 40 \mathbf{j}\} \text{ kN}$$

$$= \{9.6\mathbf{i} + 11.49\mathbf{j}\} \text{ kN}$$

Ans.

$$\mathbf{F}_2 = -26(12/13)\mathbf{i} + 26(5/13)\mathbf{j}$$

$$= \{-24\mathbf{i} + 10\mathbf{j}\} \text{ kN}$$

Ans.

$$\mathbf{F}_3 = 36 \cos 30 \mathbf{i} - 36 \sin 30 \mathbf{j}$$

$$= \{31.2\mathbf{i} + 18\mathbf{j}\} \text{ kN}$$

Ans.

Ans:

$$\mathbf{F}_1 = \{9.64\mathbf{i} + 11.5\mathbf{j}\} \text{ kN}$$

$$\mathbf{F}_2 = \{-24\mathbf{i} + 10\mathbf{j}\} \text{ kN}$$

$$\mathbf{F}_3 = \{31.2\mathbf{i} - 18\mathbf{j}\} \text{ kN}$$

*2-48.

Determine the magnitude of the resultant force and its direction measured counterclockwise from the positive x axis.

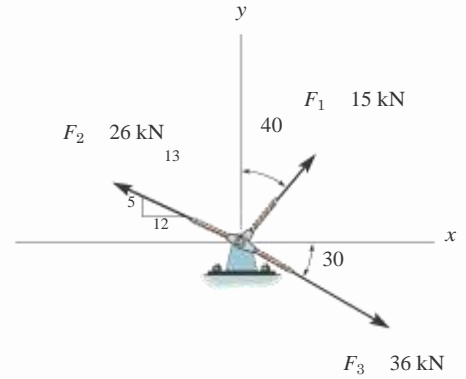

SOLUTION

$$\pm F_{Rx} = \odot F_x ; \quad F_{Rx} = 15 \sin 40^\circ - \frac{12}{13}(26) + 36 \cos 30^\circ = 16.82 \text{ kN}$$

$$+ \circ F_{Ry} = \odot F_y ; \quad F_{Ry} = 15 \cos 40^\circ + \frac{5}{13}(26) - 36 \sin 30^\circ = 3.491 \text{ kN}$$

$$F_R = \sqrt{(16.82)^2 + (3.491)^2} = 17.2 \text{ kN}$$

$$u = \tan^{-1} a \frac{3.491}{16.82} b = 11.7^\circ$$

Ans.

Ans.

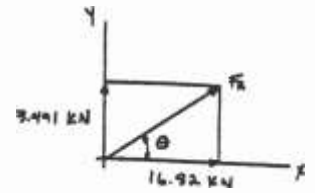

Also,

$$F_1 = \{15 \sin 40^\circ \mathbf{i} + 15 \cos 40^\circ \mathbf{j}\} \text{ kN} = \{9.64\mathbf{i} + 11.5\mathbf{j}\} \text{ kN}$$

$$F_2 = \left\{ -\frac{12}{13}(26)\mathbf{i} + \frac{5}{13}(26)\mathbf{j} \right\} \text{ kN} = \{-24\mathbf{i} + 10\mathbf{j}\} \text{ kN}$$

$$F_3 = \{36 \cos 30^\circ \mathbf{i} - 36 \sin 30^\circ \mathbf{j}\} \text{ kN} = \{31.2\mathbf{i} - 18\mathbf{j}\} \text{ kN}$$

$$F_R = F_1 + F_2 + F_3$$

$$= \{9.64\mathbf{i} + 11.5\mathbf{j}\} + \{-24\mathbf{i} + 10\mathbf{j}\} + \{31.2\mathbf{i} - 18\mathbf{j}\}$$

$$= \{16.8\mathbf{i} + 3.49\mathbf{j}\} \text{ kN}$$

Ans:

$$F_R = 17.2 \text{ kN}, u = 11.7$$

2-49.

If $F_1 = 300\text{ N}$ and $u = 10^\circ$, determine the magnitude and direction, measured counterclockwise from the positive x_i axis, of the resultant force acting on the bracket.

SOLUTION

$$\pm F_{Rx} = \odot F_x ; \quad F_{Rx} = 300 \sin 70^\circ - \frac{12}{13}(180) = 115.8\text{ N}$$

$$+ \circlearrowleft F_{Ry} = \odot F_y ; \quad F_{Ry} = 300 \cos 70^\circ + 200 + \frac{5}{13}(180) = 371.8\text{ N}$$

$$F_R = \sqrt{(115.8)^2 + (371.8)^2} = 389\text{ N}$$

$$\mathbf{f} = \tan^{-1} \frac{371.8}{115.8} \mathbf{k} = 72.71^\circ \quad \mathbf{au}$$

$$\mathbf{f}_i = 72.71^\circ - 30^\circ = 42.7^\circ$$

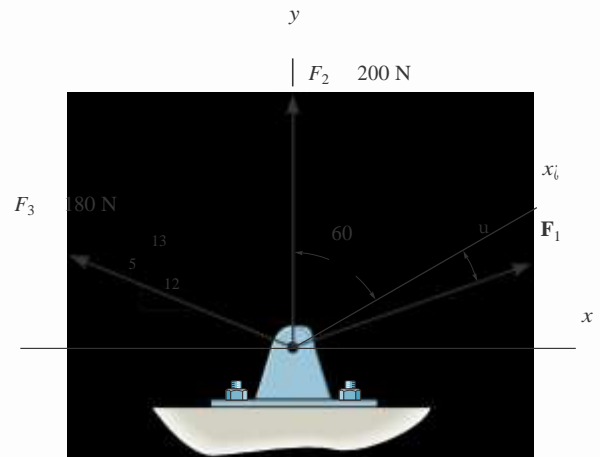

Ans.

Ans.

Ans:
 $F_R = 389\text{ N}$
 $\mathbf{f} = 42.7^\circ$

2-50.

Three forces act on the bracket. Determine the magnitude and direction u of F_1 so that the resultant force is directed along the positive x_i axis and has a magnitude of 800 N.

SOLUTION

$$\pm F_{Rx} = \circlearrowleft F_x ; \quad 800 \sin 60^\circ = F_1 \sin(60^\circ + u) - \frac{12}{13}(180)$$

$$+ \circlearrowright F_{Ry} = \circlearrowright F_y ; \quad 800 \cos 60^\circ = F_1 \cos(60^\circ + u) + 200 + \frac{5}{13}(180)$$

$$60^\circ + u = 81.34^\circ$$

$$u = 21.3^\circ$$

$$F_1 = 869 \text{ N}$$

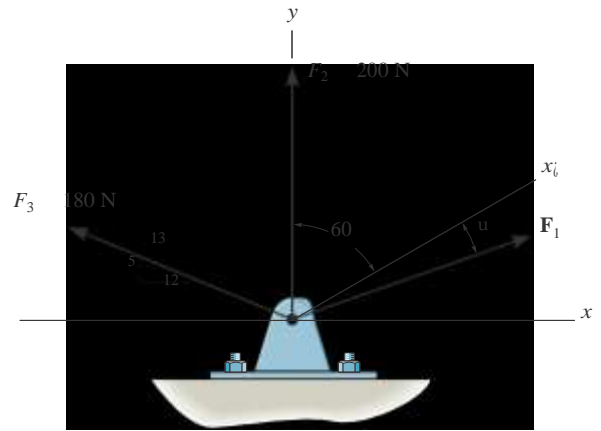

Ans.

Ans.

Ans:
 $u = 21.3$
 $F_1 = 869 \text{ N}$

2-51.

Determine the magnitude and orientation u of F_B so that the resultant force is directed along the positive y axis and has a magnitude of 1500 N.

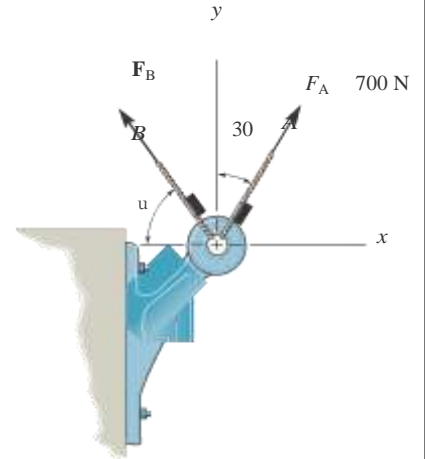

SOLUTION

Scalar Notation: Summing the force components algebraically, we have

$$\begin{aligned} \sum F_x &= \sum F_x; & 0 &= 700 \sin 30^\circ - F_B \cos u \\ F_B \cos u &= 350 & (1) \end{aligned}$$

$$\begin{aligned} \sum F_y &= \sum F_y; & 1500 &= 700 \cos 30^\circ + F_B \sin u \\ F_B \sin u &= 893.8 & (2) \end{aligned}$$

Solving Eq. (1) and (2) yields

$$u = 68.6^\circ \quad F_B = 960\text{ N} \quad \text{Ans.}$$

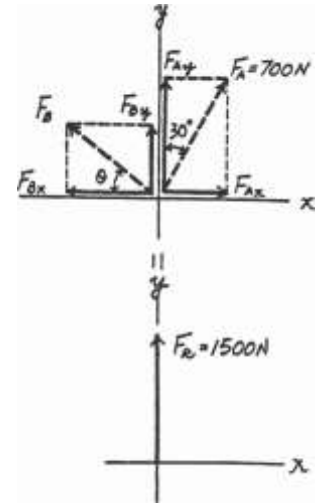

Ans:
 $u = 68.6$
 $F_B = 960\text{ N}$

*2-52.

Determine the magnitude and orientation, measured counterclockwise from the positive y axis, of the resultant force acting on the bracket, if $F_B = 600$ N and $u = 20^\circ$.

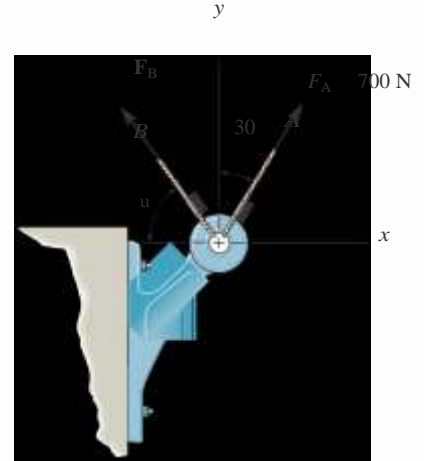

SOLUTION

Scalar Notation: Summing the force components algebraically, we have

$$\begin{aligned} \sum F_{R_x} = \Sigma F_x; \quad F_{R_x} &= 700 \sin 30^\circ - 600 \cos 20^\circ \\ &= -213.8 \text{ N} = 213.8 \text{ N} \quad \mathbf{d} \end{aligned}$$

$$\begin{aligned} + \curvearrowright F_{R_y} = \Sigma F_y; \quad F_{R_y} &= 700 \cos 30^\circ + 600 \sin 20^\circ \\ &= 811.4 \text{ N} \quad \mathbf{c} \end{aligned}$$

The magnitude of the resultant force F_R is

$$F_R = \sqrt{F_{R_x}^2 + F_{R_y}^2} = \sqrt{213.8^2 + 811.4^2} = 839 \text{ N}$$

The directional angle u measured counterclockwise from positive y axis is

$$u = \tan^{-1} \frac{F_{R_x}}{F_{R_y}} = \tan^{-1} \frac{213.8}{811.4} = 14.8^\circ$$

Ans.

Ans.

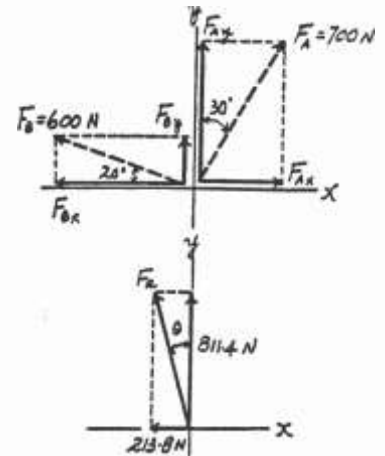

Ans:

$$\begin{aligned} F_R &= 839 \text{ N} \\ u &= 14.8 \end{aligned}$$

2-53.

Three forces act on the bracket. Determine the magnitude and direction u of \mathbf{F} so that the resultant force is directed along the positive x axis and has a magnitude of 8 kN.

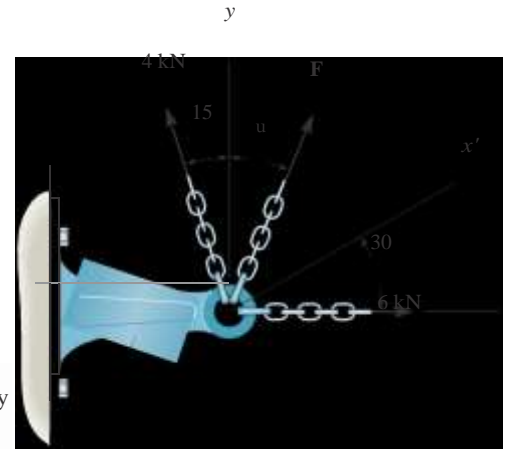

Solution

Scalar Notation. Equating the force components along the x and y axes algebraically by referring to Fig. a ,

$$\begin{aligned} \sum (F_R)_x = F_x; \quad 8 \cos 30 &= F \sin u + 6 - 4 \sin 15 \\ F \sin u &= 1.9635 \end{aligned} \tag{1}$$

$$\begin{aligned} +c(F_R)_y = F_y; \quad 8 \sin 30 &= F \cos u + 4 \cos 15 \\ F \cos u &= 0.1363 \end{aligned} \tag{2}$$

Divide Eq (1) by (2)

$$\tan u = 14.406 \quad u = 86.03^\circ = 86.0^\circ \quad \text{Ans.}$$

Substitute this result into Eq (1)

$$\begin{aligned} F \sin 86.03 &= 1.9635 \\ F &= 1.968 \text{ kN} = 1.97 \text{ kN} \quad \text{Ans.} \end{aligned}$$

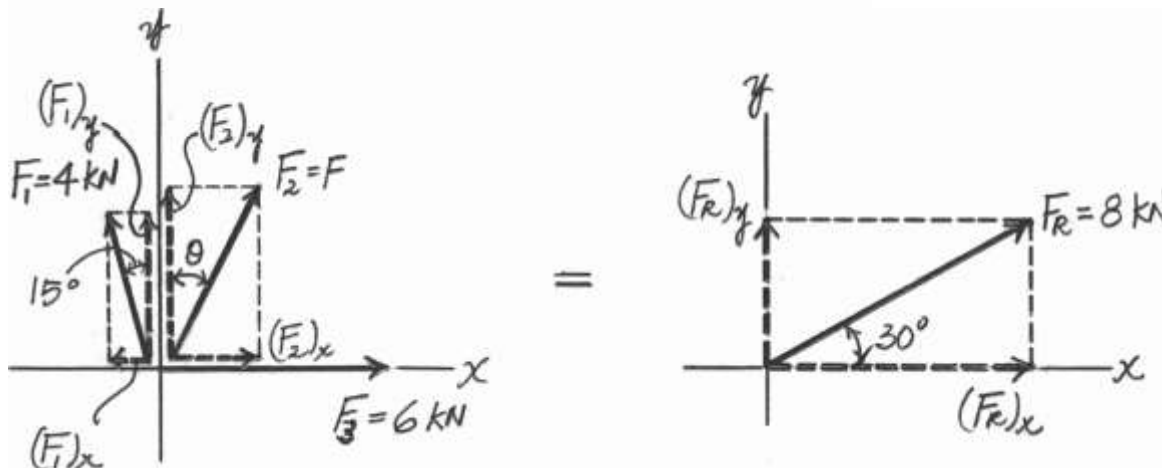

Ans:
 $u = 86.0$
 $F = 1.97 \text{ kN}$

2-54.

If $F = 5$ kN and $u = 30^\circ$, determine the magnitude of the resultant force and its direction, measured counterclockwise from the positive x axis.

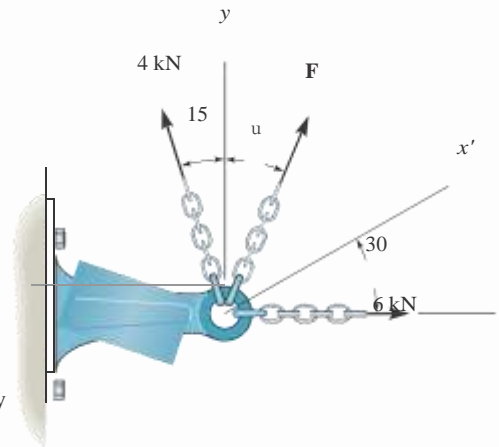

Solution

Scalar Notation. Summing the force components along x and y axes algebraically by referring to Fig. *a*,

$$\sum (F_R)_x = F_x; (F_R)_x = 5 \sin 30^\circ + 6 - 4 \sin 15^\circ = 7.465 \text{ kN} \quad \mathbf{S}$$

$$+ \sum (F_R)_y = F_y; (F_R)_y = 4 \cos 15^\circ + 5 \cos 30^\circ = 8.194 \text{ kN} \quad \mathbf{C}$$

By referring to Fig. *b*, the magnitude of the resultant force is

$$F_R = \sqrt{(F_R)_x^2 + (F_R)_y^2} = \sqrt{7.465^2 + 8.194^2} = 11.08 \text{ kN} = 11.1 \text{ kN} \quad \mathbf{Ans.}$$

And its directional angle u measured counterclockwise from the positive x axis is

$$u = \tan^{-1} \frac{(F_R)_y}{(F_R)_x} = \tan^{-1} \frac{8.194}{7.465} = 47.67^\circ = 47.7^\circ \quad \mathbf{Ans.}$$

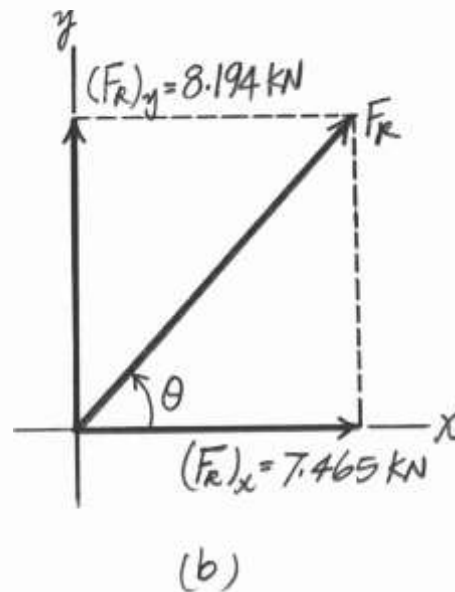
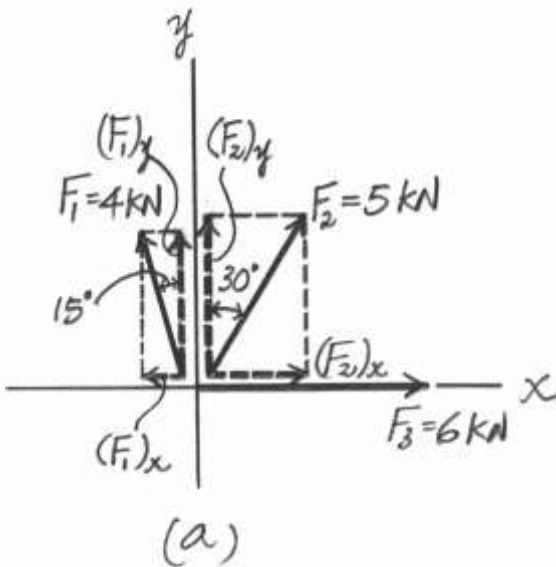

Ans:
 $F_R = 11.1 \text{ kN}$
 $u = 47.7^\circ$

2-55.

If the magnitude of the resultant force acting on the bracket is to be 450 N directed along the positive u axis, determine the magnitude of F_1 and its direction f .

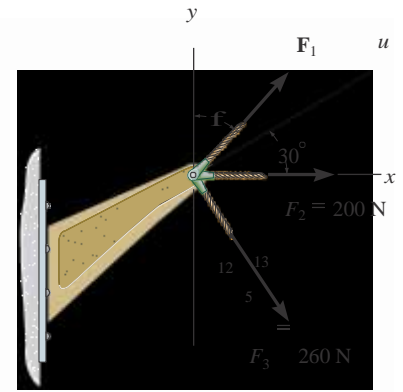

SOLUTION

Rectangular Components: By referring to Fig. *a*, the x and y components of F_1 , F_2 ,

F_3 , and F_R can be written as

$$\begin{aligned} (F_1)_x &= F_1 \sin f & (F_1)_y &= F_1 \cos f \\ (F_2)_x &= 200 \text{ N} & (F_2)_y &= 0 \\ (F_3)_x &= 260 \left(\frac{5}{13}\right) = 100 \text{ N} & (F_3)_y &= 260 \left(\frac{12}{13}\right) = 240 \text{ N} \\ (F_R)_x &= 450 \cos 30^\circ = 389.71 \text{ N} & (F_R)_y &= 450 \sin 30^\circ = 225 \text{ N} \end{aligned}$$

Resultant Force: Summing the force components algebraically along the x and y axes,

$$\begin{aligned} \pm \circlearrowleft (F_R)_x &= \circlearrowleft F_x; & 389.71 &= F_1 \sin f + 200 + 100 \\ & & F_1 \sin f &= 89.71 & (1) \\ + \circlearrowleft (F_R)_y &= \circlearrowleft F_y; & 225 &= F_1 \cos f - 240 \\ & & F_1 \cos f &= 465 & (2) \end{aligned}$$

Solving Eqs. (1) and (2), yields

$$f = 10.9^\circ \qquad F_1 = 474 \text{ N}$$

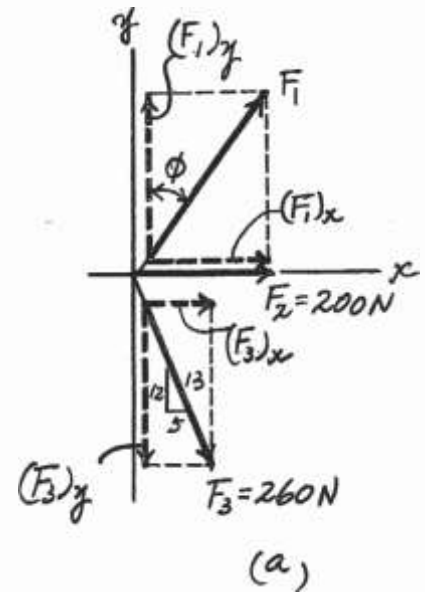

Ans.

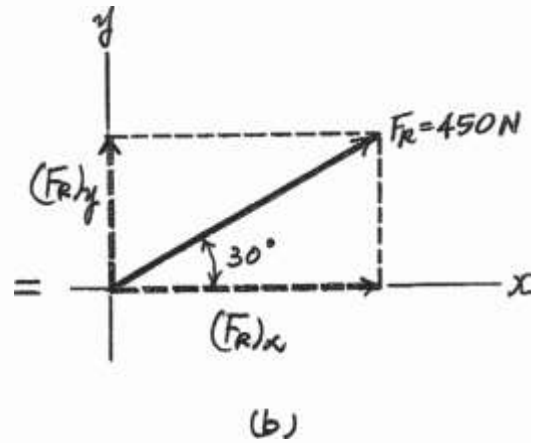

Ans:
 $f = 10.9$

$$F_1 = 474 \text{ N}$$

*2-56.

If the resultant force acting on the bracket is required to be a minimum, determine the magnitudes of F_1 and the resultant force. Set $\theta = 30^\circ$.

SOLUTION

Rectangular Components: By referring to Fig. a, the x and y components of F_1 , F_2 , and F_3 can be written as

$$(F_1)_x = F_1 \sin 30^\circ = 0.5F_1 \qquad (F_1)_y = F_1 \cos 30^\circ = 0.8660F_1$$

$$(F_2)_x = 200 \text{ N} \qquad (F_2)_y = 0$$

$$(F_3)_x = 260 \left(\frac{5}{13}\right) = 100 \text{ N} \qquad (F_3)_y = 260 \left(\frac{12}{13}\right) = 240 \text{ N}$$

Resultant Force: Summing the force components algebraically along the x and y axes,

$$\sum (F_R)_x = \sum F_x; \quad (F_R)_x = 0.5F_1 + 200 + 100 = 0.5F_1 + 300$$

$$\sum (F_R)_y = \sum F_y; \quad (F_R)_y = 0.8660F_1 - 240$$

The magnitude of the resultant force F_R is

$$\begin{aligned} F_R &= \sqrt{(F_R)_x^2 + (F_R)_y^2} \\ &= \sqrt{(0.5F_1 + 300)^2 + (0.8660F_1 - 240)^2} \\ &= \sqrt{F_1^2 - 115.69F_1 + 147\,600} \end{aligned} \qquad (1)$$

Thus,

$$F_R^2 = F_1^2 - 115.69F_1 + 147\,600 \qquad (2)$$

The first derivative of Eq. (2) is

$$2F_R \frac{dF_R}{dF_1} = 2F_1 - 115.69 \qquad (3)$$

For F_R to be minimum, $\frac{dF_R}{dF_1} = 0$. Thus, from Eq. (3)

$$2F_R \frac{dF_R}{dF_1} = 2F_1 - 115.69 = 0$$

$$F_1 = 57.846 \text{ N} = 57.8 \text{ N}$$

from Eq. (1),

$$F_R = \sqrt{(57.846)^2 - 115.69(57.846) + 147\,600} = 380 \text{ N}$$

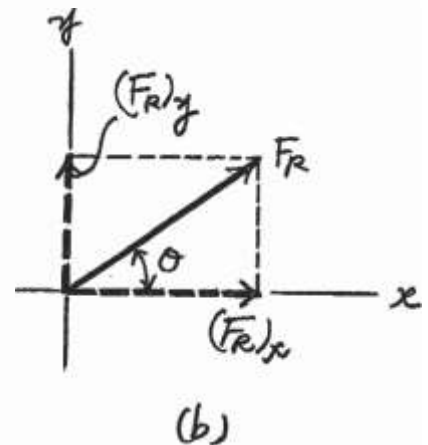
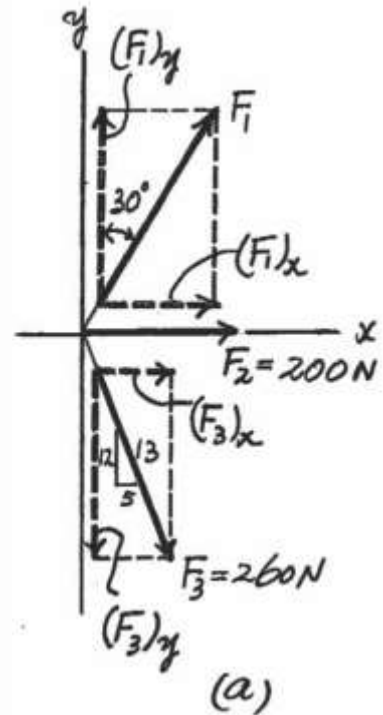
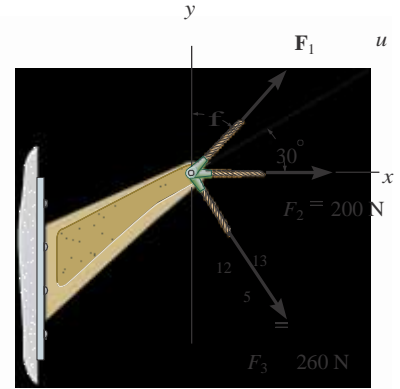

Ans.

Ans.

Ans:

$$F_1 = 57.8 \text{ N}$$

$$F_R = 380 \text{ N}$$

2-57.

Determine the magnitude of force F so that the resultant force of the three forces is as small as possible. What is the magnitude of the resultant force?

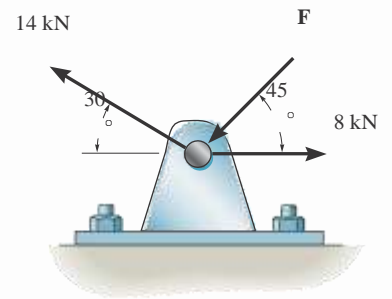

SOLUTION

$$\begin{aligned} \sum F_{Rx} = \ominus F_x; & \quad F_{Rz} = 8 - F \cos 45^\circ - 14 \cos 30^\circ \\ & = -4.1244 - F \cos 45^\circ \end{aligned}$$

$$\begin{aligned} \sum F_{Ry} = \omin� F_y; & \quad F_{Ry} = -F \sin 45^\circ + 14 \sin 30^\circ \\ & = 7 - F \sin 45^\circ \end{aligned}$$

$$F_R^2 = (-4.1244 - F \cos 45^\circ)^2 + (7 - F \sin 45^\circ)^2 \quad (1)$$

$$\frac{dF_R}{dF}$$

$$2F_R \frac{dF_R}{dF} = 2(-4.1244 - F \cos 45^\circ)(-\cos 45^\circ) + 2(7 - F \sin 45^\circ)(-\sin 45^\circ) = 0$$

$$F = 2.03 \text{ kN}$$

Ans.

From Eq. (1); $F_R = 7.87 \text{ kN}$

Ans.

Also, from the figure require

$$\begin{aligned} (F_R)_{x_i} = 0 = \omin� F_{x_i}; & \quad F + 14 \sin 15^\circ - 8 \cos 45^\circ = 0 \\ & \quad F = 2.03 \text{ kN} \end{aligned}$$

Ans.

$$\begin{aligned} (F_R)_{y_i} = \omin� F_{y_i}; & \quad F_R = 14 \cos 15^\circ - 8 \sin 45^\circ \\ & \quad F_R = 7.87 \text{ kN} \end{aligned}$$

Ans.

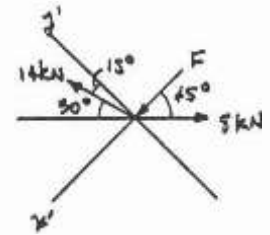
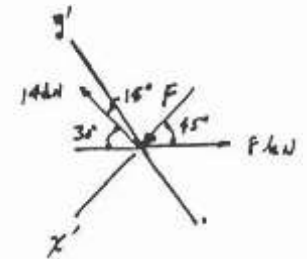

Ans:

$$F = 2.03 \text{ kN}$$

$$F_R = 7.87 \text{ kN}$$

2-58.

Express \mathbf{F}_1 and \mathbf{F}_2 as Cartesian vectors.

SOLUTION

$$\begin{aligned} \mathbf{F}_1 &= -30 \sin 30^\circ \mathbf{i} - 30 \cos 30^\circ \mathbf{j} \\ &= 5 - 15.0 \mathbf{i} - 26.0 \mathbf{j} \text{ kN} \end{aligned}$$

$$\begin{aligned} \mathbf{F}_2 &= -\frac{5}{13} 1262 \mathbf{i} + \frac{12}{13} 1262 \mathbf{j} \\ &= \{-10.0 \mathbf{i} + 24.0 \mathbf{j}\} \text{ kN} \end{aligned}$$

Ans.

Ans.

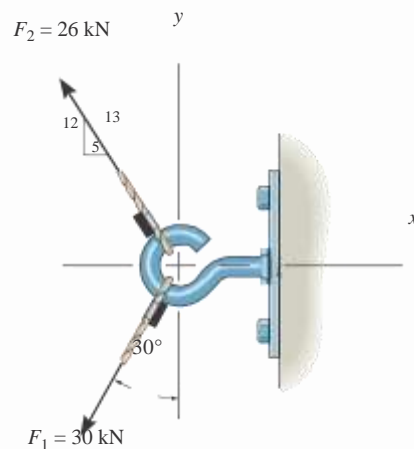

Ans:

$$\mathbf{F}_1 = \{-15.0\mathbf{i} - 26.0\mathbf{j}\} \text{ kN}$$

$$\mathbf{F}_2 = \{-10.0\mathbf{i} + 24.0\mathbf{j}\} \text{ kN}$$

2-59.

Determine the magnitude of the resultant force and its direction measured counterclockwise from the positive x axis.

SOLUTION

$$\begin{aligned} \pm F_{Rx} &= \odot F_x; & F_{Rx} &= -30 \sin 30^\circ - \frac{5}{13} 1262 = -25 \text{ kN} \\ + \circ F_{Ry} &= \odot F_y; & F_{Ry} &= -30 \cos 30^\circ + \frac{12}{13} 1262 = -1.981 \text{ kN} \\ F_R &= \sqrt{(-25)^2 + (-1.981)^2} = 25.1 \text{ kN} \\ \phi &= \tan^{-1} \frac{1.981}{25} = 4.53^\circ \\ u &= 180^\circ + 4.53^\circ = 185^\circ \end{aligned}$$

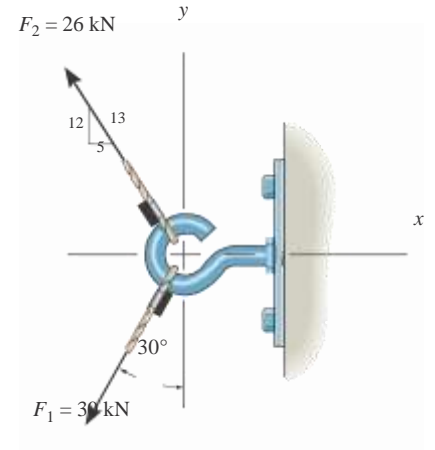

Ans.

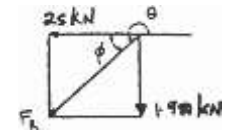

Ans.

Ans:
 $F_R = 25.1 \text{ kN}$
 $u = 185$

*2-60. Determine the coordinate angles for F_2 and then express each force acting on the bracket as a Cartesian vector.

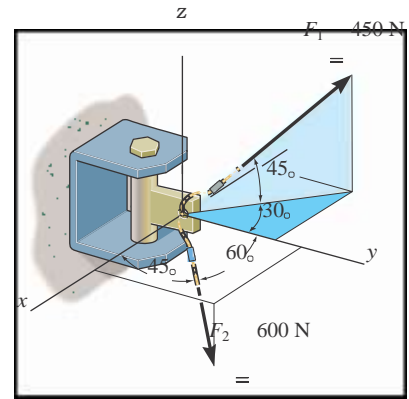

Solution

Rectangular Components: Since $\cos^2 \alpha_2 + \cos^2 \beta_2 + \cos^2 \gamma_2 = 1$, then $\cos \gamma_2 = \sqrt{1 - \cos^2 45^\circ - \cos^2 60^\circ} = 0.5$. However, it is required $\gamma_2 > 90^\circ$, thus, $\gamma_2 = \cos^{-1}(-0.5) = 120^\circ$. By resolving F_1 and F_2 into their x , y , and z components, as shown in Figs. *a* and *b*, respectively F_1 and F_2 can be expressed in Cartesian vector form as

$$F_1 = 450 \cos 45^\circ \sin 30^\circ (-i) + 450 \cos 45^\circ \cos 30^\circ (+j) + 450 \sin 45^\circ (+k)$$

$$= 5 - 159i + 276j + 318k \text{ N}$$

Ans.

$$F_2 = 600 \cos 45^\circ i + 600 \cos 60^\circ j + 600 \cos 120^\circ k$$

$$= 542i + 300j - 300k \text{ N}$$

Ans.

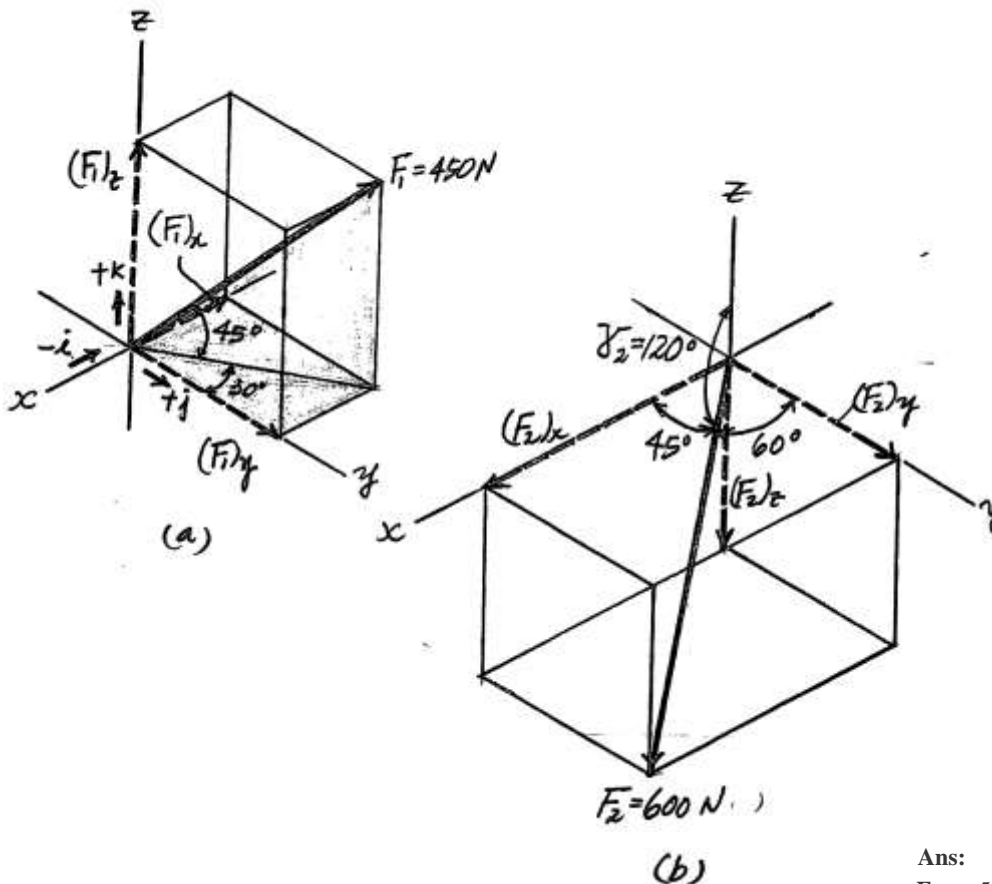

Ans:

$$F_1 = 5 - 159i + 276j + 318k \text{ N}$$

$$F_2 = 542i + 300j - 300k \text{ N}$$

2-61. Determine the magnitude and coordinate direction angles of the resultant force acting on the bracket.

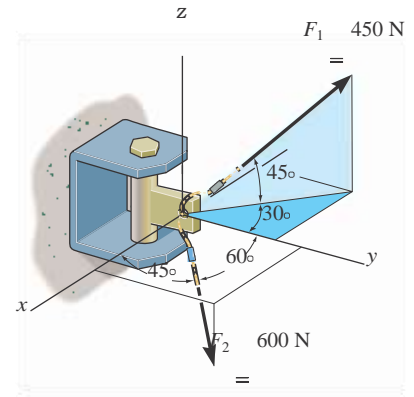

Solution

Rectangular Components: Since $\cos^2 a_2 + \cos^2 b_2 + \cos^2 g_2 = 1$, then $\cos g_{2z} = \sqrt{1 - \cos^2 45^\circ - \cos^2 60^\circ} = 0.52$. However, it is required $a_2 \geq 90^\circ$, thus, $g_2 = \cos^{-1}(-0.52) = 120^\circ$. By resolving \mathbf{F}_1 and \mathbf{F}_2 into their x , y , and z components, as shown in Figs. *a* and *b*, respectively \mathbf{F}_1 and \mathbf{F}_2 can be expressed in Cartesian vector form, as

$$\begin{aligned} \mathbf{F}_1 &= 450 \cos 45^\circ \sin 30^\circ (-\mathbf{i}) + 450 \cos 45^\circ \cos 30^\circ (+\mathbf{j}) + 450 \sin 45^\circ (+\mathbf{k}) \\ &= \{-159.10\mathbf{i} + 275.57\mathbf{j} + 318.20\mathbf{k}\} \text{ N} \end{aligned}$$

Ans.

$$\begin{aligned} \mathbf{F}_2 &= 600 \cos 45^\circ \mathbf{i} + 600 \cos 60^\circ \mathbf{j} + 600 \cos 120^\circ \mathbf{k} \\ &= \{424\mathbf{i} + 300\mathbf{j} - 300\mathbf{k}\} \text{ N} \end{aligned}$$

Ans.

Resultant Force: By adding \mathbf{F}_1 and \mathbf{F}_2 vectorally, we obtain \mathbf{F}_R .

$$\begin{aligned} \mathbf{F}_R &= \mathbf{F}_1 + \mathbf{F}_2 \\ &= (-159.10\mathbf{i} + 275.57\mathbf{j} + 318.20\mathbf{k}) + (424.26\mathbf{i} + 300\mathbf{j} - 300\mathbf{k}) \\ &= \{265.16\mathbf{i} + 575.57\mathbf{j} + 18.20\mathbf{k}\} \text{ N} \end{aligned}$$

The magnitude of \mathbf{F}_R is

$$\begin{aligned} F_R &= \sqrt{(F_R)_x^2 + (F_R)_y^2 + (F_R)_z^2} \\ &= \sqrt{265.16^2 + 575.57^2 + 18.20^2} = 633.97 \text{ N} \approx 634 \text{ N} \end{aligned}$$

Ans.

The coordinate direction angles of \mathbf{F}_R are

$$a = \cos^{-1} \frac{(F_R)_x}{F_R} = \cos^{-1} \frac{265.16}{633.97} = 65.3^\circ$$

Ans.

$$b = \cos^{-1} \frac{(F_R)_y}{F_R} = \cos^{-1} \frac{575.57}{633.97} = 24.8^\circ$$

Ans.

$$g = \cos^{-1} \frac{(F_R)_z}{F_R} = \cos^{-1} \frac{18.20}{633.97} = 88.4^\circ$$

Ans.

Ans:

$$\mathbf{F}_1 = \{-159.10\mathbf{i} + 275.57\mathbf{j} + 318.20\mathbf{k}\} \text{ N}$$

$$\mathbf{F}_2 = \{424\mathbf{i} + 300\mathbf{j} - 300\mathbf{k}\} \text{ N}$$

$$F_R = 634 \text{ N}$$

$$a = 65.3^\circ$$

$$b = 24.8^\circ$$

$$g = 88.4^\circ$$

2-62.

Determine the magnitude and coordinate direction angles of the force \mathbf{F} acting on the support. The component of \mathbf{F} in the x - y plane is 7 kN.

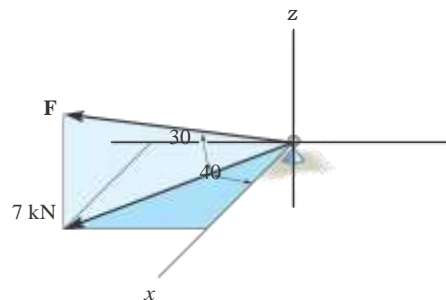

Solution

Coordinate Direction Angles. The unit vector of \mathbf{F} is

$$\begin{aligned} \mathbf{u}_F &= \cos 30 \cos 40 \mathbf{i} - \cos 30 \sin 40 \mathbf{j} + \sin 30 \mathbf{k} \\ &= \{0.6634\mathbf{i} - 0.5567\mathbf{j} + 0.5 \mathbf{k}\} \end{aligned}$$

Thus,

$$\cos a = 0.6634; \quad a = 48.44 = 48.4 \quad \text{Ans.}$$

$$\cos b = -0.5567; \quad b = 123.83 = 124 \quad \text{Ans.}$$

$$\cos g = 0.5; \quad g = 60 \quad \text{Ans.}$$

The magnitude of \mathbf{F} can be determined from

$$F \cos 30 = 7; \quad F = 8.083 \text{ kN} = 8.08 \text{ kN} \quad \text{Ans.}$$

Ans:
 $a = 48.4$
 $b = 124$
 $g = 60$
 $F = 8.08 \text{ kN}$

2-63.

The bolt is subjected to the force \mathbf{F} , which has components acting along the x , y , z axes as shown. If the magnitude of \mathbf{F} is 80 N, and $a = 60^\circ$ and $g = 45^\circ$, determine the magnitudes of its components.

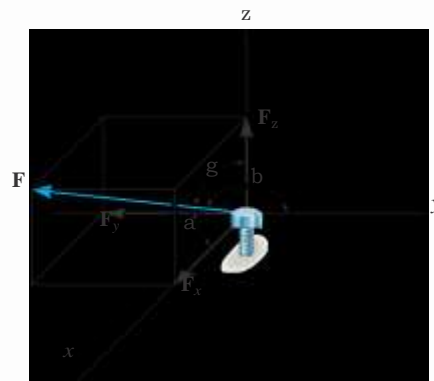

SOLUTION

$$\begin{aligned} \cos b &= \sqrt{1 - \cos^2 a - \cos^2 g} \\ &= \sqrt{1 - \cos^2 60^\circ - \cos^2 45^\circ} \end{aligned}$$

$$b = 120^\circ$$

$$F_x = |80 \cos 60^\circ| = 40 \text{ N}$$

Ans.

$$F_y = |80 \cos 120^\circ| = 40 \text{ N}$$

Ans.

$$F_z = |80 \cos 45^\circ| = 56.6 \text{ N}$$

Ans.

Ans:

$$F_x = 40 \text{ N}$$

$$F_y = 40 \text{ N}$$

$$F_z = 56.6 \text{ N}$$

*2-64.

The stock mounted on the lathe is subjected to a force of 60 N. Determine the coordinate direction angle b and express the force as a Cartesian vector.

SOLUTION

$$1 = \sqrt{\cos^2 a + \cos^2 b + \cos^2 c}$$

$$1 = \cos^2 60^\circ + \cos^2 b + \cos^2 45^\circ$$

$$\cos b = \pm 0.5$$

$$b = 60^\circ, 120^\circ$$

Use

$$b = 120^\circ$$

$$\begin{aligned} \mathbf{F} &= 60 \text{ N}(\cos 60^\circ \mathbf{i} + \cos 120^\circ \mathbf{j} + \cos 45^\circ \mathbf{k}) \\ &= \{30\mathbf{i} - 30\mathbf{j} + 42.4\mathbf{k}\} \text{ N} \end{aligned}$$

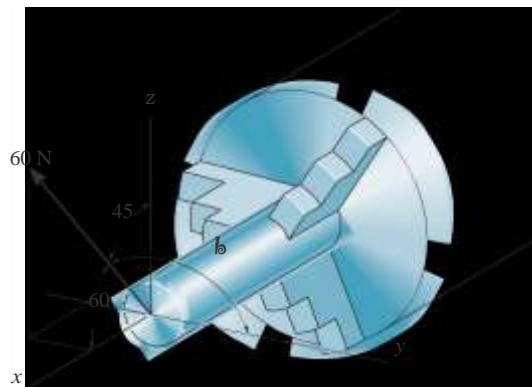

Ans.

Ans.

Ans:
 $b = 120^\circ$
 $\mathbf{F} = \{30\mathbf{i} - 30\mathbf{j} + 42.4\mathbf{k}\} \text{ N}$

2-65. Specify the magnitude F_3 and directions $a_3, b_3,$ and g_3 of \mathbf{F}_3 so that the resultant force of the three forces is $\mathbf{F}_R = \{9\mathbf{j}\}$ kN.

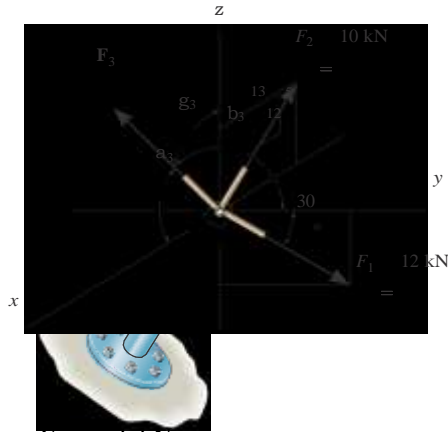

SOLUTION

Initial Guesses: $F_{3x} = 1$ kN, $F_{3y} = 1$ kN, $F_{3z} = 1$ kN

Given $\mathbf{F}_R = \{9\mathbf{j}\}$ kN

$$F_{3x} = 0$$

$$F_{3y} = F_1 \cos \theta = \frac{F_2}{\sqrt{c^2 + d^2}} \cdot c$$

$$F_{3z} = F_1 \sin \theta = \frac{F_2}{\sqrt{c^2 + d^2}} \cdot d$$

$F_1 = 12$ kN, $c = 5$

$F_2 = 10$ kN, $d = 12$

$\mathbf{F}_R = \{9\mathbf{j}\}$ kN

Find F_{3x}, F_{3y}, F_{3z}

$F_{3x} = 9.2$ kN

$F_{3y} = 1.4$ kN

$F_{3z} = 2.2$ kN

$\theta = 15.5^\circ$

$\alpha = \arccos \frac{F_{3x}}{F_3} = 98.4^\circ$

$\beta = 77.0^\circ$

Ans.

Ans:

$$\begin{aligned}F_3 &= 9.6 \text{ kN} \\a_3 &= 15.5 \\b_3 &= 98.4 \\g_3 &= 77.0\end{aligned}$$

2-66.

Determine the magnitude and coordinate direction angles of the resultant force, and sketch this vector on the coordinate system.

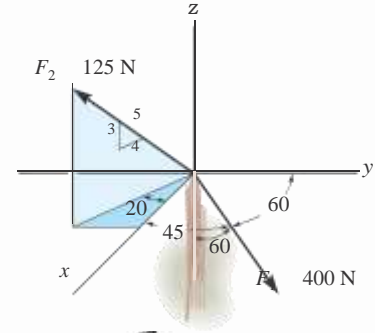

Solution

Cartesian Vector Notation. For \mathbf{F}_1 and \mathbf{F}_2 ,

$$\mathbf{F}_1 = 400 (\cos 45^\circ \mathbf{i} + \cos 60^\circ \mathbf{j} - \cos 60^\circ \mathbf{k}) = \{282.84\mathbf{i} + 200\mathbf{j} - 200\mathbf{k}\} \text{ N}$$

$$\mathbf{F}_2 = 125 \left(\frac{4}{5} (\cos 20^\circ) \mathbf{i} - \frac{4}{5} (\sin 20^\circ) \mathbf{j} + \frac{3}{5} \mathbf{k} \right) = \{93.97\mathbf{i} - 34.20\mathbf{j} + 75.0\mathbf{k}\}$$

Resultant Force.

$$\begin{aligned} \mathbf{F}_R &= \mathbf{F}_1 + \mathbf{F}_2 \\ &= \{282.84\mathbf{i} + 200\mathbf{j} - 200\mathbf{k}\} + \{93.97\mathbf{i} - 34.20\mathbf{j} + 75.0\mathbf{k}\} \\ &= \{376.81\mathbf{i} + 165.80\mathbf{j} - 125.00\mathbf{k}\} \text{ N} \end{aligned}$$

The magnitude of the resultant force is

$$\begin{aligned} F_R &= \sqrt{(F_R)_x^2 + (F_R)_y^2 + (F_R)_z^2} = \sqrt{376.81^2 + 165.80^2 + (-125.00)^2} \\ &= 430.23 \text{ N} = 430 \text{ N} \end{aligned}$$

The coordinate direction angles are

$$\cos a = \frac{(F_R)_x}{F_R} = \frac{376.81}{430.23}; \quad a = 28.86^\circ = 28.9^\circ$$

$$\cos b = \frac{(F_R)_y}{F_R} = \frac{165.80}{430.23}; \quad b = 67.33^\circ = 67.3^\circ$$

$$\cos g = \frac{(F_R)_z}{F_R} = \frac{-125.00}{430.23}; \quad g = 106.89^\circ = 107^\circ$$

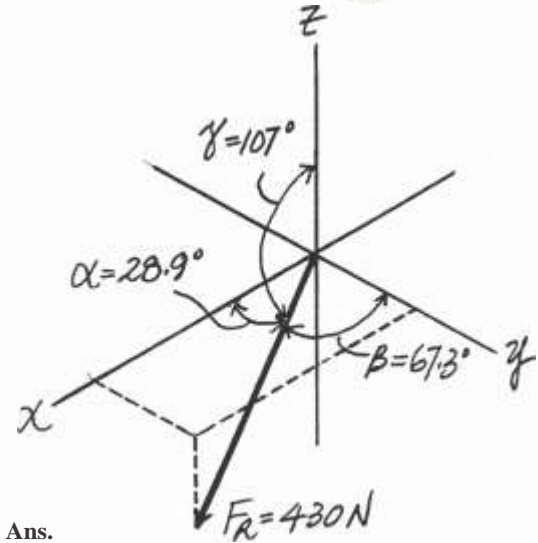

Ans.

Ans.

Ans.

Ans.

Ans:

$$\begin{aligned} F_R &= 430 \text{ N} \\ a &= 28.9 \\ b &= 67.3 \\ g &= 107 \end{aligned}$$

2-67.

Determine the magnitude and coordinate direction angles of the resultant force, and sketch this vector on the coordinate system.

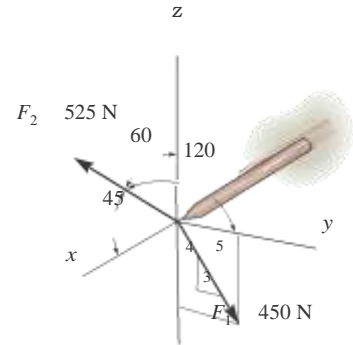

Solution

Cartesian Vector Notation. For F_1 and F_2 ,

$$F_1 = 450 a \frac{3}{5} \mathbf{j} - \frac{4}{5} \mathbf{k} b = \{270\mathbf{j} - 360\mathbf{k}\} \text{ N}$$

$$F_2 = 525 (\cos 45^\circ \mathbf{i} + \cos 120^\circ \mathbf{j} + \cos 60^\circ \mathbf{k}) = \{371.23\mathbf{i} - 262.5\mathbf{j} + 262.5\mathbf{k}\} \text{ N}$$

Resultant Force.

$$\begin{aligned} \mathbf{F}_R &= \mathbf{F}_1 + \mathbf{F}_2 \\ &= \{270\mathbf{j} - 360\mathbf{k}\} + \{371.23\mathbf{i} - 262.5\mathbf{j} + 262.5\mathbf{k}\} \\ &= \{371.23\mathbf{i} + 7.50\mathbf{j} - 97.5\mathbf{k}\} \text{ N} \end{aligned}$$

The magnitude of the resultant force is

$$\begin{aligned} F_R &= \sqrt{(F_R)_x^2 + (F_R)_y^2 + (F_R)_z^2} = \sqrt{371.23^2 + 7.50^2 + (-97.5)^2} \\ &= 383.89 \text{ N} = 384 \text{ N} \end{aligned}$$

The coordinate direction angles are

$$\cos a = \frac{(F_R)_x}{F_R} = \frac{371.23}{383.89}; \quad a = 14.76^\circ = 14.8^\circ$$

$$\cos b = \frac{(F_R)_y}{F_R} = \frac{7.50}{383.89}; \quad b = 88.88^\circ = 88.9^\circ$$

$$\cos g = \frac{(F_R)_z}{F_R} = \frac{-97.5}{383.89}; \quad g = 104.71^\circ = 105^\circ$$

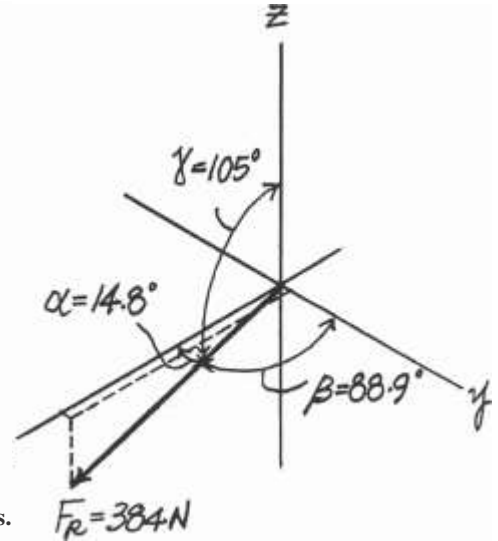

Ans.

Ans.

Ans.

Ans.

Ans:

$$\begin{aligned} F_R &= 384 \text{ N} \\ \cos a &= \frac{371.23}{383.89}; \quad a = 14.8^\circ \\ \cos b &= \frac{7.50}{383.89}; \quad b = 88.9^\circ \\ \cos g &= \frac{-97.5}{383.89}; \quad g = 105^\circ \end{aligned}$$

*2-68. Determine the magnitude and coordinate direction angles of F_3 so that the resultant of the three forces acts along the positive y axis and has a magnitude of 600 N.

SOLUTION

Given:

$$F = 600 \text{ N}$$

$$F_1 = 180 \text{ N}$$

$$F_2 = 300 \text{ N}$$

$$1 = 30^\circ$$

$$2 = 40^\circ$$

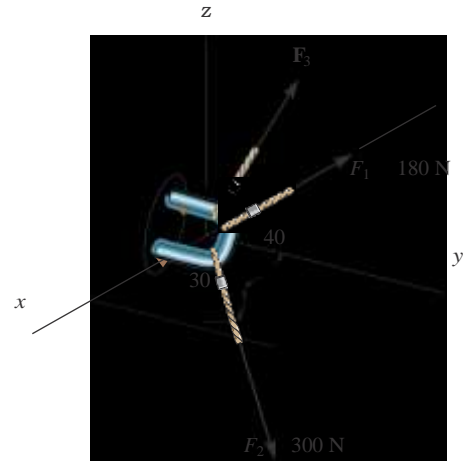

Initial guesses:

$$40 \quad 50$$

$$50 \quad F_3 = 45 \text{ N}$$

Given

$$F_{Rx} = F_x; \quad 0 = F_1 \cos 1 + F_2 \cos 2 + F_3 \cos 3$$

$$F_{Ry} = F_y; \quad F = F_2 \cos 1 \cos 2 + F_3 \cos 3$$

$$F_{Rz} = F_z; \quad 0 = F_2 \sin 1 + F_3 \cos 3$$

$$\cos^2 2 + \cos^2 1 + \cos^2 3 = 1$$

F_3

$$88.3$$

Find F_3

$$F_3 = 428 \text{ N}$$

$$20.6 \text{ deg}$$

$$69.5$$

Ans:

$$F_3 = 428 \text{ N}$$

$$a = 88.3$$

$$b = 20.6$$

$$g = 69.5$$

2-69. Determine the magnitude and coordinate direction angles of F_3 so that the resultant of the three forces is zero.

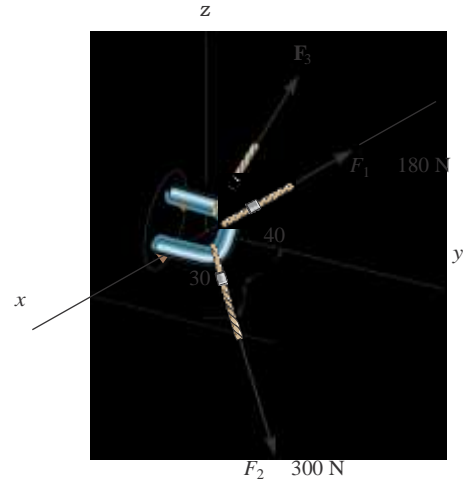

SOLUTION

Given:

$$F_1 = 180 \text{ N} \quad \alpha_1 = 30^\circ$$

$$F_2 = 300 \text{ N} \quad \alpha_2 = 40^\circ$$

Initial guesses:

$$F_3 = 45 \text{ N}$$

$$F_3 = 45 \text{ N}$$

Given

$$F_{Rx} = F_x; \quad 0 = F_1 \cos \alpha_1 \sin \alpha_2 + F_3 \cos \alpha_3$$

$$F_{Ry} = F_y; \quad 0 = F_2 \cos \alpha_2 + F_3 \cos \alpha_3$$

$$F_{Rz} = F_z; \quad 0 = F_1 \sin \alpha_1 + F_3 \cos \alpha_3$$

$$\cos^2 \alpha_1 + \cos^2 \alpha_2 + \cos^2 \alpha_3 = 1$$

F_3

$$87.0$$

Find F_3

$$F_3 = 250 \text{ N}$$

$$142.9 \text{ deg}$$

Ans.

$$53.1$$

Ans:

$$F_3 = 250 \text{ N}$$

$$a = 87.0$$

$$b = 142.9$$

2-70.

The screw eye is subjected to the two forces shown. Express each force in Cartesian vector form and then determine the resultant force. Find the magnitude and coordinate direction angles of the resultant force.

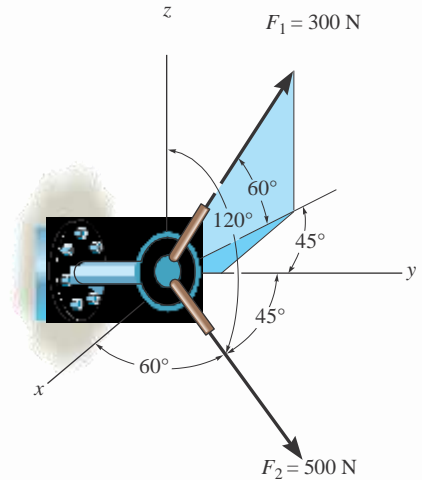

SOLUTION

$$\begin{aligned} \mathbf{F}_1 &= 300(-\cos 60^\circ \sin 45^\circ \mathbf{i} + \cos 60^\circ \cos 45^\circ \mathbf{j} + \sin 60^\circ \mathbf{k}) \\ &= \{-106.07\mathbf{i} + 106.07\mathbf{j} + 259.81\mathbf{k}\} \text{ N} \\ &= \{-106\mathbf{i} + 106\mathbf{j} + 260\mathbf{k}\} \text{ N} \end{aligned}$$

Ans.

$$\begin{aligned} \mathbf{F}_2 &= 500(\cos 60^\circ \mathbf{i} + \cos 45^\circ \mathbf{j} + \cos 120^\circ \mathbf{k}) \\ &= \{250.0\mathbf{i} + 353.55\mathbf{j} - 250.0\mathbf{k}\} \text{ N} \\ &= \{250\mathbf{i} + 354\mathbf{j} - 250\mathbf{k}\} \text{ N} \end{aligned}$$

Ans.

$$\begin{aligned} \mathbf{F}_R &= \mathbf{F}_1 + \mathbf{F}_2 \\ &= -106.07\mathbf{i} + 106.07\mathbf{j} + 259.81\mathbf{k} + 250.0\mathbf{i} + 353.55\mathbf{j} - 250.0\mathbf{k} \\ &= 143.93\mathbf{i} + 459.62\mathbf{j} + 9.81\mathbf{k} \\ &= \{144\mathbf{i} + 460\mathbf{j} + 9.81\mathbf{k}\} \text{ N} \end{aligned}$$

Ans.

$$F_R = \sqrt{143.93^2 + 459.62^2 + 9.81^2} = 481.73 \text{ N} = 482 \text{ N}$$

Ans.

$$\mathbf{u}_{F_R} = \frac{\mathbf{F}_R}{F_R} = \frac{143.93\mathbf{i} + 459.62\mathbf{j} + 9.81\mathbf{k}}{481.73} = 0.2988\mathbf{i} + 0.9541\mathbf{j} + 0.02036\mathbf{k}$$

$$\cos a = 0.2988 \quad a = 72.6^\circ$$

Ans.

$$\cos b = 0.9541 \quad b = 17.4^\circ$$

Ans.

$$\cos g = 0.02036 \quad g = 88.8^\circ$$

Ans.

Ans:

$$\mathbf{F}_1 = \{-106\mathbf{i} + 106\mathbf{j} + 260\mathbf{k}\} \text{ N}$$

$$\mathbf{F}_2 = \{250\mathbf{i} + 354\mathbf{j} - 250\mathbf{k}\} \text{ N}$$

$$\mathbf{F}_R = \{144\mathbf{i} + 460\mathbf{j} + 9.81\mathbf{k}\} \text{ N}$$

$$F_R = 482 \text{ N}$$

$$a = 72.6$$

$$b = 17.4$$

$$g = 88.8$$

2-71.

Determine the coordinate direction angles of \mathbf{F}_1 .

SOLUTION

$$\mathbf{F}_1 = 300(-\cos 60^\circ \sin 45^\circ \mathbf{i} + \cos 60^\circ \cos 45^\circ \mathbf{j} + \sin 60^\circ \mathbf{k})$$

$$= \{-106.07\mathbf{i} + 106.07\mathbf{j} + 259.81\mathbf{k}\} \text{ N}$$

$$= \{-106\mathbf{i} + 106\mathbf{j} + 260\mathbf{k}\} \text{ N}$$

$$\mathbf{u}_1 = \frac{\mathbf{F}_1}{300} = -0.3536\mathbf{i} + 0.3536\mathbf{j} + 0.8660\mathbf{k}$$

$$a_1 = \cos^{-1}(-0.3536) = 111^\circ$$

$$b_1 = \cos^{-1}(0.3536) = 69.3^\circ$$

$$g_1 = \cos^{-1}(0.8660) = 30.0^\circ$$

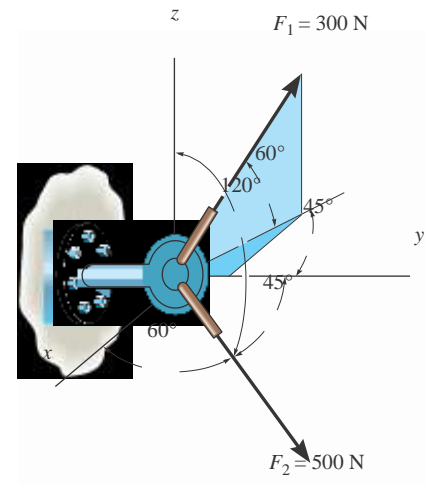

Ans.

Ans.

Ans.

Ans:

$$a_1 = 111$$

$$b_1 = 69.3$$

$$g_1 = 30.0$$

*2-72.

Determine the magnitude and coordinate direction angles of the resultant force, and sketch this vector on the coordinate system.

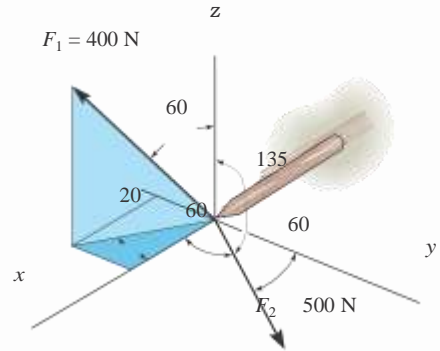

Solution

Cartesian Vector Notation. For F_1 and F_2 ,

$$\begin{aligned} F_1 &= 400 (\sin 60 \cos 20 \mathbf{i} - \sin 60 \sin 20 \mathbf{j} + \cos 60 \mathbf{k}) \\ &= \{325.52\mathbf{i} - 118.48\mathbf{j} + 200\mathbf{k}\} \text{ N} \end{aligned}$$

$$\begin{aligned} F_2 &= 500 (\cos 60 \mathbf{i} + \cos 60 \mathbf{j} + \cos 135 \mathbf{k}) \\ &= \{250\mathbf{i} + 250\mathbf{j} - 353.55\mathbf{k}\} \text{ N} \end{aligned}$$

Resultant Force.

$$\begin{aligned} F_R &= F_1 + F_2 \\ &= (325.52\mathbf{i} - 118.48\mathbf{j} + 200\mathbf{k}) + (250\mathbf{i} + 250\mathbf{j} - 353.55\mathbf{k}) \\ &= \{575.52\mathbf{i} + 131.52\mathbf{j} - 153.55\mathbf{k}\} \text{ N} \end{aligned}$$

The magnitude of the resultant force is

$$F_R = \sqrt{(F_R)_x^2 + (F_R)_y^2 + (F_R)_z^2} = \sqrt{2575.52^2 + 131.52^2 + (-153.55)^2} = 610.00 \text{ N} = 610 \text{ N} \quad \text{Ans.}$$

The coordinate direction angles are

$$\cos a = \frac{(F_R)_x}{F_R} = \frac{575.52}{610.00} \quad a = 19.36 = 19.4 \quad \text{Ans.}$$

$$\cos b = \frac{(F_R)_y}{F_R} = \frac{131.52}{610.00} \quad b = 77.549 = 77.5 \quad \text{Ans.}$$

$$\cos g = \frac{(F_R)_z}{F_R} = \frac{-153.55}{610.00} \quad g = 104.58 = 105 \quad \text{Ans.}$$

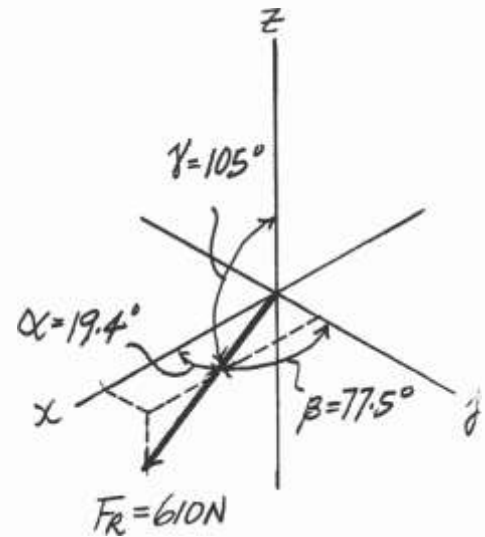

Ans:
 $F_R = 610 \text{ N}$
 $a = 19.4$
 $b = 77.5$
 $g = 105$

2-73.

Determine the coordinate direction angles of force \mathbf{F}_1 .

SOLUTION

Rectangular Components: By referring to Figs. *a*, the x , y , and z components of \mathbf{F}_1 can be written as

$$(F_1)_x = 600 \frac{4}{5} \cos 30^\circ \text{ N} \quad (F_1)_y = 600 \frac{4}{5} \sin 30^\circ \text{ N} \quad (F_1)_z = 600 \frac{3}{5} \text{ N}$$

Thus, \mathbf{F}_1 expressed in Cartesian vector form can be written as

$$\begin{aligned} \mathbf{F}_1 &= 600 \frac{4}{5} \cos 30^\circ (+\mathbf{i}) + \frac{4}{5} \sin 30^\circ (-\mathbf{j}) + \frac{3}{5} (600) \mathbf{k} \text{ N} \\ &= 600[0.6928\mathbf{i} - 0.4\mathbf{j} + 0.6\mathbf{k}] \text{ N} \end{aligned}$$

Therefore, the unit vector for \mathbf{F}_1 is given by

$$\mathbf{u}_{F_1} = \frac{\mathbf{F}_1}{F_1} = \frac{600(0.6928\mathbf{i} - 0.4\mathbf{j} + 0.6\mathbf{k})}{600} = 0.6928\mathbf{i} - 0.4\mathbf{j} + 0.6\mathbf{k}$$

The coordinate direction angles of \mathbf{F}_1 are

$$a = \cos^{-1}(\mathbf{u}_{F_1})_x = \cos^{-1}(0.6928) = 46.1^\circ$$

Ans.

$$b = \cos^{-1}(\mathbf{u}_{F_1})_y = \cos^{-1}(-0.4) = 114^\circ$$

Ans.

$$g = \cos^{-1}(\mathbf{u}_{F_1})_z = \cos^{-1}(0.6) = 53.1^\circ$$

Ans.

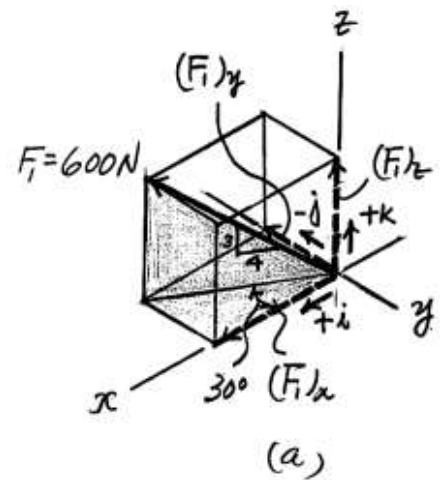
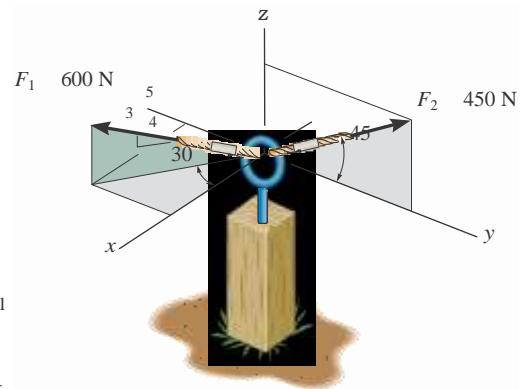

Ans:

$$\begin{aligned} a &= 46.1 \\ b &= 114 \text{ g} \\ &= 53.1 \end{aligned}$$

2-74.

Determine the magnitude and coordinate direction angles of the resultant force acting on the eyebolt.

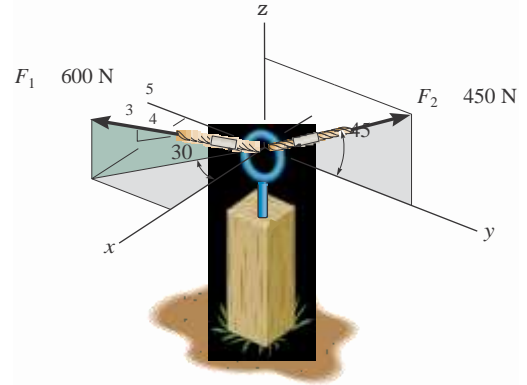

SOLUTION

Force Vectors: By resolving F_1 and F_2 into their x , y , and z components, as shown in Figs. *a* and *b*, respectively, they are expressed in Cartesian vector form as

$$\begin{aligned} F_1 &= 600a \frac{4}{5}b \cos 30^\circ(+i) + 600a \frac{4}{5}b \sin 30^\circ(-j) + 600a \frac{3}{5}b(+k) \\ &= 5415.69i - 240j + 360k \text{ N} \end{aligned}$$

$$\begin{aligned} F_2 &= 0i + 450 \cos 45^\circ(+j) + 450 \sin 45^\circ(+k) \\ &= 5318.20j + 318.20k \text{ N} \end{aligned}$$

Resultant Force: The resultant force acting on the eyebolt can be obtained by vectorially adding F_1 and F_2 . Thus,

$$\begin{aligned} F_R &= F_1 + F_2 \\ &= (415.69i - 240j + 360k) + (318.20j + 318.20k) \\ &= 5415.69i + 78.20j + 678.20k \text{ N} \end{aligned}$$

The magnitude of F_R is given by

$$\begin{aligned} F_R &= \sqrt{(F_R)_x^2 + (F_R)_y^2 + (F_R)_z^2} \\ &= \sqrt{(415.69)^2 + (78.20)^2 + (678.20)^2} = 799.29 \text{ N} = 799 \text{ N} \end{aligned}$$

The coordinate direction angles of F_R are

$$a = \cos^{-1} \frac{(F_R)_x}{F_R} = \cos^{-1} \frac{415.69}{799.29} = 58.7^\circ$$

$$b = \cos^{-1} \frac{(F_R)_y}{F_R} = \cos^{-1} \frac{78.20}{799.29} = 84.4^\circ$$

$$c = \cos^{-1} \frac{(F_R)_z}{F_R} = \cos^{-1} \frac{678.20}{799.29} = 32.0^\circ$$

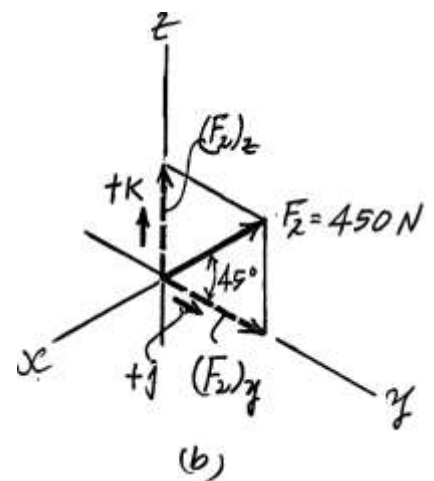
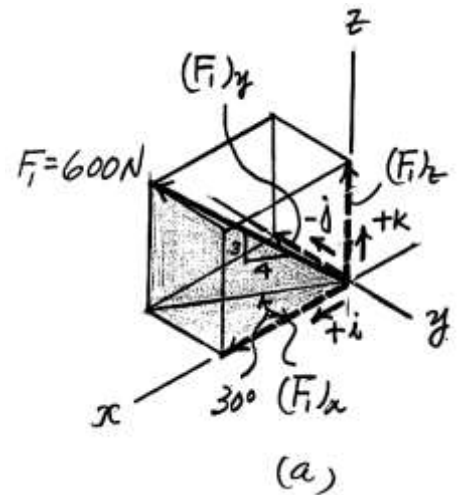

Ans.

Ans.

Ans.

Ans.

Ans:
 $F_R = 799 \text{ N}$
 $a = 58.7$
 $b = 84.4$

$$g = 32.0$$

2-75.

Express each force in Cartesian vector form.

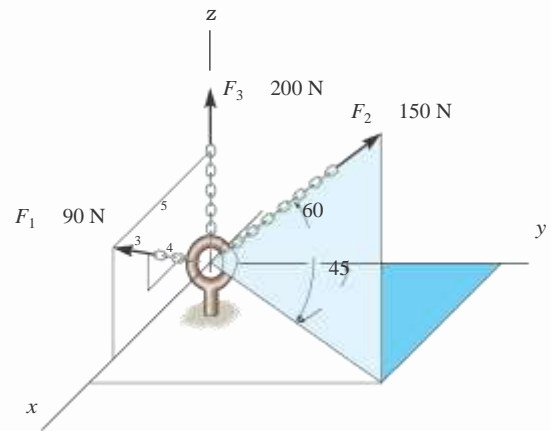

Solution

Cartesian Vector Notation. For F_1 , F_2 and F_3 ,

$$F_1 = 90 \text{ a } \frac{4}{5} \mathbf{i} + \frac{3}{5} \mathbf{k} \text{ b} = \{72.0\mathbf{i} + 54.0\mathbf{k}\} \text{ N}$$

$$F_2 = 150 (\cos 60 \sin 45 \mathbf{i} + \cos 60 \cos 45 \mathbf{j} + \sin 60 \mathbf{k})$$

$$= \{53.03\mathbf{i} + 53.03\mathbf{j} + 129.90\mathbf{k}\} \text{ N}$$

$$= \{53.0\mathbf{i} + 53.0\mathbf{j} + 130\mathbf{k}\} \text{ N}$$

$$F_3 = \{200 \mathbf{k}\}$$

Ans.

Ans.

Ans.

Ans:

$$F_1 = \{72.0\mathbf{i} + 54.0\mathbf{k}\} \text{ N}$$

$$F_2 = \{53.0\mathbf{i} + 53.0\mathbf{j} + 130\mathbf{k}\} \text{ N}$$

$$F_3 = \{200 \mathbf{k}\}$$

*2-76.

Determine the magnitude and coordinate direction angles of the resultant force, and sketch this vector on the coordinate system.

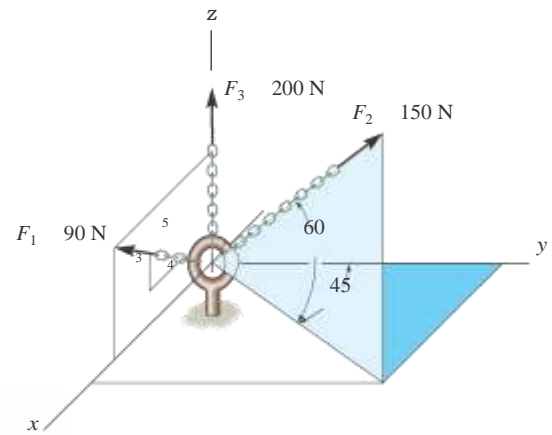

Solution

Cartesian Vector Notation. For \mathbf{F}_1 , \mathbf{F}_2 and \mathbf{F}_3 ,

$$\mathbf{F}_1 = 90 \frac{4}{5} \mathbf{i} + \frac{3}{5} \mathbf{k} = \{72.0\mathbf{i} + 54.0\mathbf{k}\} \text{ N}$$

$$\begin{aligned} \mathbf{F}_2 &= 150 (\cos 60 \sin 45 \mathbf{i} + \cos 60 \cos 45 \mathbf{j} + \sin 60 \mathbf{k}) \\ &= \{53.03\mathbf{i} + 53.03\mathbf{j} + 129.90\mathbf{k}\} \text{ N} \end{aligned}$$

$$\mathbf{F}_3 = \{200\mathbf{k}\} \text{ N}$$

Resultant Force.

$$\begin{aligned} \mathbf{F} &= \mathbf{F}_1 + \mathbf{F}_2 + \mathbf{F}_3 \\ &= (72.0\mathbf{i} + 54.0\mathbf{k}) + (53.03\mathbf{i} + 53.03\mathbf{j} + 129.90\mathbf{k}) + (200\mathbf{k}) \\ &= \{125.03\mathbf{i} + 53.03\mathbf{j} + 383.90\mathbf{k}\} \text{ N} \end{aligned}$$

The magnitude of the resultant force is

$$\begin{aligned} F_R &= \sqrt{(F_R)_x^2 + (F_R)_y^2 + (F_R)_z^2} = \sqrt{125.03^2 + 53.03^2 + 383.90^2} \\ &= 407.22 \text{ N} = 407 \text{ N} \end{aligned}$$

And the coordinate direction angles are

$$\cos a = \frac{(F_R)_x}{F_R} = \frac{125.03}{407.22}; \quad a = 72.12 = 72.1$$

Ans.

$$\cos b = \frac{(F_R)_y}{F_R} = \frac{53.03}{407.22}; \quad b = 82.52 = 82.5$$

Ans.

$$\cos g = \frac{(F_R)_z}{F_R} = \frac{383.90}{407.22}; \quad g = 19.48 = 19.5$$

Ans.

Ans.

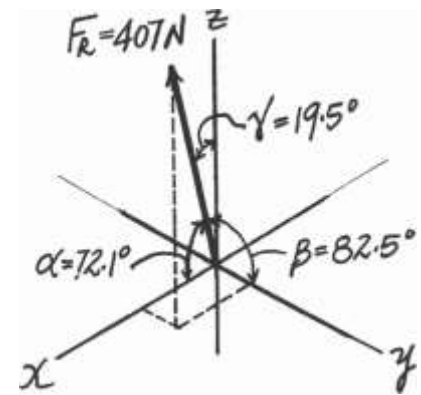

Ans:

$$\begin{aligned} F_R &= 407 \text{ N} \\ a &= 72.1 \\ b &= 82.5 \\ g &= 19.5 \end{aligned}$$

2-77.

The cables attached to the screw eye are subjected to the three forces shown. Express each force in Cartesian vector form and determine the magnitude and coordinate direction angles of the resultant force.

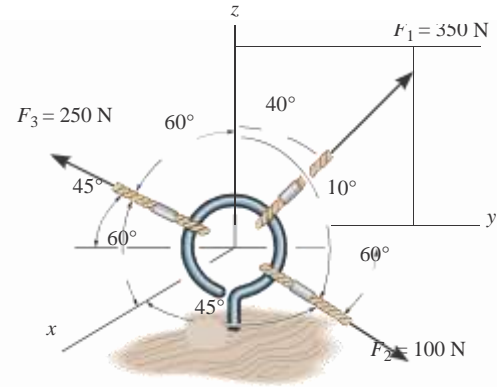

SOLUTION

Cartesian Vector Notation:

$$\begin{aligned} \mathbf{F}_1 &= 350\sin 40^\circ\mathbf{j} + \cos 40^\circ\mathbf{k} \text{ N} \\ &= 5224.98\mathbf{j} + 268.12\mathbf{k} \text{ N} \\ &= 5225\mathbf{j} + 268\mathbf{k} \text{ N} \end{aligned}$$

Ans.

$$\begin{aligned} \mathbf{F}_2 &= 100\cos 45^\circ\mathbf{i} + \cos 60^\circ\mathbf{j} + \cos 120^\circ\mathbf{k} \text{ N} \\ &= 570.71\mathbf{i} + 50.0\mathbf{j} - 50.0\mathbf{k} \text{ N} \\ &= 570.7\mathbf{i} + 50.0\mathbf{j} - 50.0\mathbf{k} \text{ N} \end{aligned}$$

Ans.

$$\begin{aligned} \mathbf{F}_3 &= 250\cos 60^\circ\mathbf{i} + \cos 135^\circ\mathbf{j} + \cos 60^\circ\mathbf{k} \text{ N} \\ &= 5125.0\mathbf{i} - 176.78\mathbf{j} + 125.0\mathbf{k} \text{ N} \\ &= 5125\mathbf{i} - 177\mathbf{j} + 125\mathbf{k} \text{ N} \end{aligned}$$

Ans.

Resultant Force:

$$\begin{aligned} \mathbf{F}_R &= \mathbf{F}_1 + \mathbf{F}_2 + \mathbf{F}_3 \\ &= 5170.71 + 125.02\mathbf{i} + 1224.98 + 50.0 - 176.782\mathbf{j} + 1268.12 - 50.0 + 125.02\mathbf{k} \text{ N} \\ &= 5195.71\mathbf{i} + 98.20\mathbf{j} + 343.12\mathbf{k} \text{ N} \end{aligned}$$

The magnitude of the resultant force is

$$\begin{aligned} F_R &= \sqrt{F_{R_x}^2 + F_{R_y}^2 + F_{R_z}^2} \\ &= \sqrt{5195.71^2 + 98.20^2 + 343.12^2} \\ &= 407.03 \text{ N} = 407 \text{ N} \end{aligned}$$

Ans.

The coordinate direction angles are

$$\cos a = \frac{F_{R_x}}{F_R} = \frac{5195.71}{407.03} \quad a = 61.3^\circ$$

Ans.

$$\cos b = \frac{F_{R_y}}{F_R} = \frac{98.20}{407.03} \quad b = 76.0^\circ$$

Ans.

$$\cos g = \frac{F_{R_z}}{F_R} = \frac{343.12}{407.03} \quad g = 32.5^\circ$$

Ans.

Ans:

$$\mathbf{F}_1 = \{225\mathbf{j} + 268\mathbf{k}\} \text{ N}$$

$$\mathbf{F}_2 = \{70.7\mathbf{i} + 50.0\mathbf{j} - 50.0\mathbf{k}\} \text{ N}$$

$$\mathbf{F}_3 = \{125\mathbf{i} - 177\mathbf{j} + 125\mathbf{k}\} \text{ N}$$

$$F_R = 407 \text{ N}$$

$$a = 61.3$$

$$b = 76.0$$

$$g = 32.5$$

2-78. The mast is subjected to the three forces shown. Determine the coordinate direction angles a_1, b_1, g_1 of \mathbf{F}_1 so that the resultant force acting on the mast is $\mathbf{F}_R = 5350\mathbf{i}6 \text{ N}$.

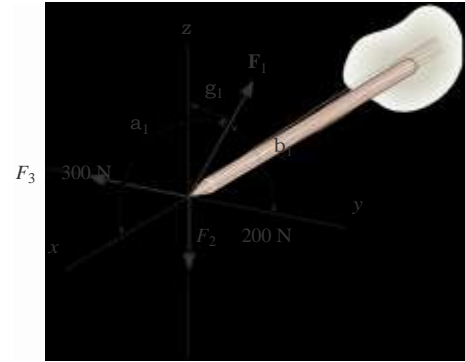

Solution

$$\mathbf{F}_1 = 500 \cos a_1 \mathbf{i} + 500 \cos b_1 \mathbf{j} + 500 \cos g_1 \mathbf{k}$$

$$\mathbf{F}_R = \mathbf{F}_1 + (-300\mathbf{j}) + (-200\mathbf{k})$$

$$350\mathbf{i} = 500 \cos a_1 \mathbf{i} + (500 \cos b_1 - 300)\mathbf{j} + (500 \cos g_1 - 200)\mathbf{k}$$

$$350 = 500 \cos a_1; \quad a_1 = 45.6$$

$$0 = 500 \cos b_1 - 300; \quad b_1 = 53.1$$

$$0 = 500 \cos g_1 - 200; \quad g_1 = 66.4$$

Ans.

Ans.

Ans.

Ans:
 $a_1 = 45.6$
 $b_1 = 53.1$
 $g_1 = 66.4$

2-79. The mast is subjected to the three forces shown.

Determine the coordinate direction angles a_1, b_1, g_1 of \mathbf{F}_1 so that the resultant force acting on the mast is zero.

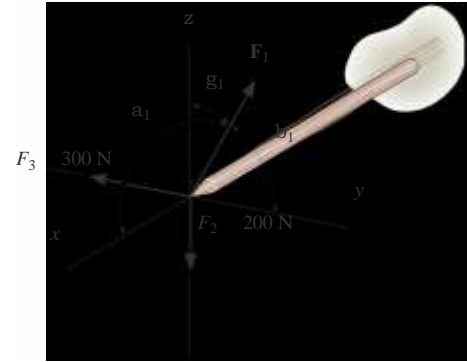

Solution

$$\mathbf{F}_1 = 500 \cos a_1 \mathbf{i} + 500 \cos b_1 \mathbf{j} + 500 \cos g_1 \mathbf{k} \text{ N}$$

$$\mathbf{F}_2 = 500 - 200 \mathbf{k} \text{ N}$$

$$\mathbf{F}_3 = 500 - 300 \mathbf{j} \text{ N}$$

$$\mathbf{F}_R = \mathbf{F}_1 + \mathbf{F}_2 + \mathbf{F}_3 = 0$$

$$500 \cos a_1 = 0; \quad a_1 = 90$$

$$500 \cos b_1 = 300; \quad b_1 = 53.1$$

$$500 \cos g_1 = 200; \quad g_1 = 66.4$$

Ans.

Ans.

Ans.

Ans:
 $a_1 = 90$
 $b_1 = 53.1$
 $g_1 = 66.4$

*2-80.

Express each force as a Cartesian vector.

SOLUTION

Rectangular Components: By referring to Figs. *a* and *b*, the *x*, *y*, and *z* components of \mathbf{F}_1 and \mathbf{F}_2 can be written as

$$(F_1)_x = 300 \cos 30^\circ = 259.8 \text{ N} \quad (F_2)_x = 500 \cos 45^\circ \sin 30^\circ = 176.78 \text{ N}$$

$$(F_1)_y = 0 \quad (F_2)_y = 500 \cos 45^\circ \cos 30^\circ = 306.19 \text{ N}$$

$$(F_1)_z = 300 \sin 30^\circ = 150 \text{ N} \quad (F_2)_z = 500 \sin 45^\circ = 353.55 \text{ N}$$

Thus, \mathbf{F}_1 and \mathbf{F}_2 can be written in Cartesian vector form as

$$\begin{aligned} \mathbf{F}_1 &= 259.81(+\mathbf{i}) + 0\mathbf{j} + 150(-\mathbf{k}) \\ &= \{260\mathbf{i} - 150\mathbf{k}\} \text{ N} \end{aligned}$$

$$\begin{aligned} \mathbf{F}_2 &= 176.78(+\mathbf{i}) + 306.19(+\mathbf{j}) + 353.55(-\mathbf{k}) \\ &= 2\{177\mathbf{i} + 306\mathbf{j} - 354\mathbf{k}\} \text{ N} \end{aligned}$$

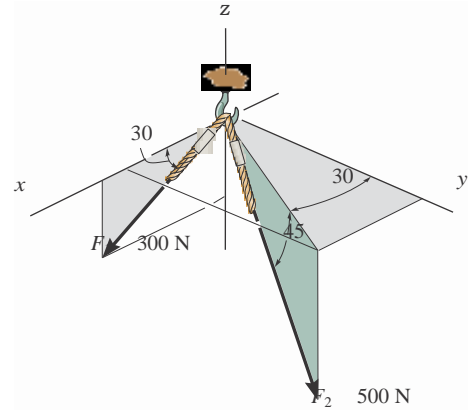

Ans.

Ans.

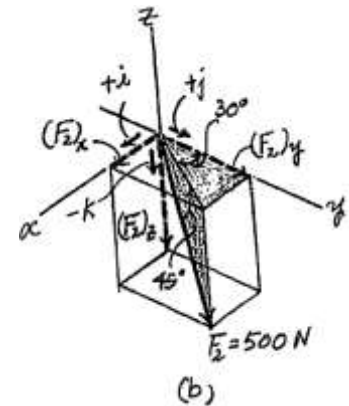
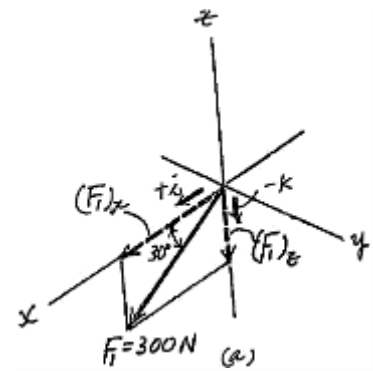

Ans:

$$\mathbf{F}_1 = \{260\mathbf{i} - 150\mathbf{k}\} \text{ N}$$

$$\mathbf{F}_2 = 2\{177\mathbf{i} + 306\mathbf{j} - 354\mathbf{k}\} \text{ N}$$

2-81.

Determine the magnitude and coordinate direction angles of the resultant force acting on the hook.

SOLUTION

Force Vectors: By resolving \mathbf{F}_1 and \mathbf{F}_2 into their x , y , and z components, as shown in Figs. *a* and *b*, respectively, \mathbf{F}_1 and \mathbf{F}_2 can be expressed in Cartesian vector form as

$$\begin{aligned} \mathbf{F}_1 &= 300 \cos 30^\circ(+\mathbf{i}) + 0\mathbf{j} + 300 \sin 30^\circ(-\mathbf{k}) \\ &= \{259.81\mathbf{i} - 150\mathbf{k}\} \text{ N} \end{aligned}$$

$$\begin{aligned} \mathbf{F}_2 &= 500 \cos 45^\circ \sin 30^\circ(+\mathbf{i}) + 500 \cos 45^\circ \cos 30^\circ(+\mathbf{j}) + 500 \sin 45^\circ(-\mathbf{k}) \\ &= \{176.78\mathbf{i} - 306.19\mathbf{j} - 353.55\mathbf{k}\} \text{ N} \end{aligned}$$

Resultant Force: The resultant force acting on the hook can be obtained by vectorally adding \mathbf{F}_1 and \mathbf{F}_2 . Thus,

$$\begin{aligned} \mathbf{F}_R &= \mathbf{F}_1 + \mathbf{F}_2 \\ &= (259.81\mathbf{i} - 150\mathbf{k}) + (176.78\mathbf{i} + 306.19\mathbf{j} - 353.55\mathbf{k}) \\ &= \{436.58\mathbf{i} + 306.19\mathbf{j} - 503.55\mathbf{k}\} \text{ N} \end{aligned}$$

The magnitude of \mathbf{F}_R is

$$\begin{aligned} F_R &= \sqrt{(F_R)_x^2 + (F_R)_y^2 + (F_R)_z^2} \\ &= \sqrt{(436.58)^2 + (306.19)^2 + (-503.55)^2} = 733.43 \text{ N} = 733 \text{ N} \quad \text{Ans.} \end{aligned}$$

The coordinate direction angles of \mathbf{F}_R are

$$u_x = \cos^{-1} \left(\frac{(F_R)_x}{F_R} \right) = \cos^{-1} \left(\frac{436.58}{733.43} \right) = 53.5^\circ \quad \text{Ans.}$$

$$u_y = \cos^{-1} \left(\frac{(F_R)_y}{F_R} \right) = \cos^{-1} \left(\frac{306.19}{733.43} \right) = 65.3^\circ \quad \text{Ans.}$$

$$u_z = \cos^{-1} \left(\frac{(F_R)_z}{F_R} \right) = \cos^{-1} \left(\frac{-503.55}{733.43} \right) = 133^\circ \quad \text{Ans.}$$

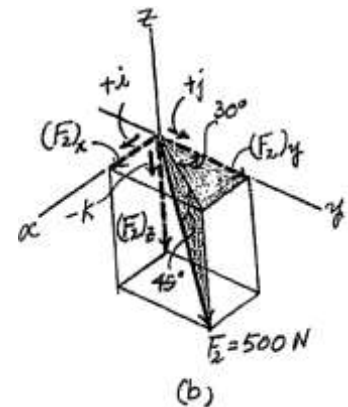
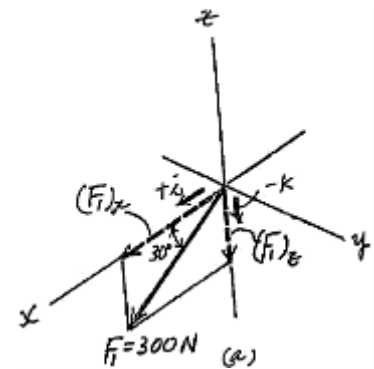
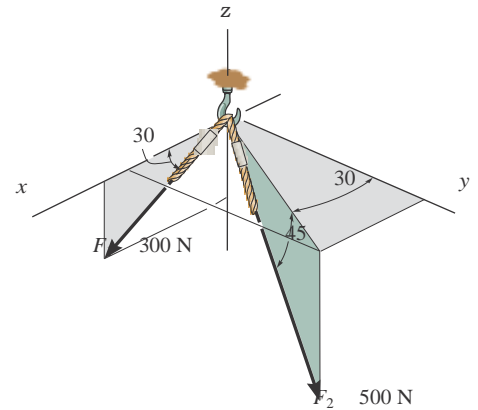

Ans:

$$\begin{aligned}F_R &= 733 \text{ N} \\u_x &= 53.5 \\u_y &= 65.3 \\u_z &= 133\end{aligned}$$

2-82.

Three forces act on the ring. If the resultant force F_R has a magnitude and direction as shown, determine the magnitude and the coordinate direction angles of force F_3 .

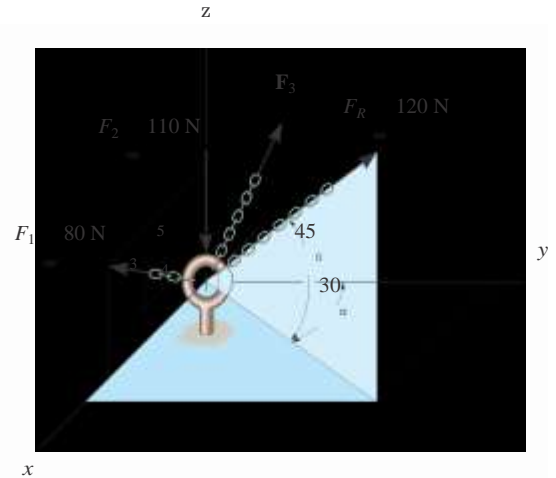

SOLUTION

Cartesian Vector Notation:

$$F_R = 120\{\cos 45^\circ \sin 30^\circ \mathbf{i} + \cos 45^\circ \cos 30^\circ \mathbf{j} + \sin 45^\circ \mathbf{k}\} \text{ N}$$

$$= \{42.43\mathbf{i} + 73.48\mathbf{j} + 84.85\mathbf{k}\} \text{ N}$$

$$F_1 = 80\left(\frac{4}{5}\mathbf{i} + \frac{3}{5}\mathbf{k}\right) \text{ N} = \{64.0\mathbf{i} + 48.0\mathbf{k}\} \text{ N}$$

$$F_2 = \{-110\mathbf{k}\} \text{ N}$$

$$F_3 = \{F_{3x}\mathbf{i} + F_{3y}\mathbf{j} + F_{3z}\mathbf{k}\} \text{ N}$$

Resultant Force:

$$F_R = F_1 + F_2 + F_3$$

$$\{42.43\mathbf{i} + 73.48\mathbf{j} + 84.85\mathbf{k}\} = \{64.0 + F_{3x}\}\mathbf{i} + \{F_{3y}\}\mathbf{j} + \{48.0 - 110 + F_{3z}\}\mathbf{k}$$

Equating \mathbf{i} , \mathbf{j} and \mathbf{k} components, we have

$$64.0 + F_{3x} = 42.43 \qquad F_{3x} = -21.57 \text{ N}$$

$$F_{3y} = 73.48 \text{ N}$$

$$48.0 - 110 + F_{3z} = 84.85 \qquad F_{3z} = 146.85 \text{ N}$$

The magnitude of force F_3 is

$$F_3 = \sqrt{F_{3x}^2 + F_{3y}^2 + F_{3z}^2}$$

$$= \sqrt{(-21.57)^2 + 73.48^2 + 146.85^2}$$

$$= 165.62 \text{ N} = 166 \text{ N}$$

Ans.

The coordinate direction angles for F_3 are

$$\cos a = \frac{F_{3x}}{F_3} = \frac{-21.57}{165.62} \qquad a = 97.5^\circ \qquad \text{Ans.}$$

$$\cos b = \frac{F_{3y}}{F_3} = \frac{73.48}{165.62} \qquad b = 63.7^\circ \qquad \text{Ans.}$$

$$\cos c = \frac{F_{3z}}{F_3} = \frac{146.85}{165.62} \qquad c = 27.5^\circ \qquad \text{Ans.}$$

Ans:
 $F_3 = 166 \text{ N}$
 $a = 97.5^\circ$

$$b = 63.7$$
$$g = 27.5$$

2-83.

Determine the coordinate direction angles of \mathbf{F}_1 and \mathbf{F}_R .

SOLUTION

Unit Vector of \mathbf{F}_1 and \mathbf{F}_R :

$$\mathbf{u}_{F_1} = \frac{4}{5} \mathbf{i} + \frac{3}{5} \mathbf{k} = 0.8\mathbf{i} + 0.6\mathbf{k}$$

$$\begin{aligned} \mathbf{u}_R &= \cos 45^\circ \sin 30^\circ \mathbf{i} + \cos 45^\circ \cos 30^\circ \mathbf{j} + \sin 45^\circ \mathbf{k} \\ &= 0.3536\mathbf{i} + 0.6124\mathbf{j} + 0.7071\mathbf{k} \end{aligned}$$

Thus, the coordinate direction angles \mathbf{F}_1 and \mathbf{F}_R are

$$\cos a_{F_1} = 0.8 \quad a_{F_1} = 36.9^\circ$$

$$\cos b_{F_1} = 0 \quad b_{F_1} = 90.0^\circ$$

$$\cos g_{F_1} = 0.6 \quad g_{F_1} = 53.1^\circ$$

$$\cos a_R = 0.3536 \quad a_R = 69.3^\circ$$

$$\cos b_R = 0.6124 \quad b_R = 52.2^\circ$$

$$\cos g_R = 0.7071 \quad g_R = 45.0^\circ$$

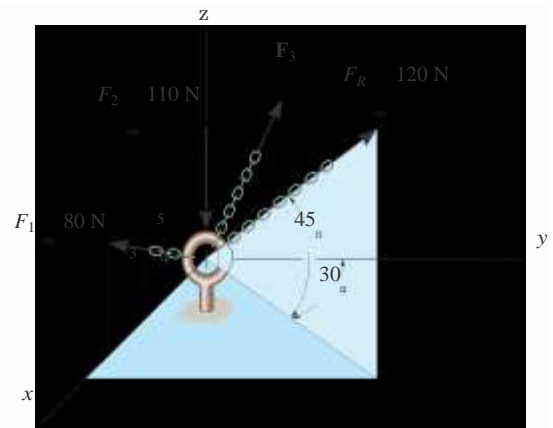

Ans.

Ans.

Ans.

Ans.

Ans.

Ans.

Ans:

$$a_{F_1} = 36.9$$

$$b_{F_1} = 90.0$$

$$g_{F_1} = 53.1$$

$$a_R = 69.3$$

$$b_R = 52.2$$

$$g_R = 45.0$$

***2-84.**

The pole is subjected to the force \mathbf{F} , which has components acting along the x , y , z axes as shown. If the magnitude of \mathbf{F} is 3 kN, $b = 30^\circ$, and $g = 75^\circ$, determine the magnitudes of its three components.

SOLUTION

$$\cos^2 a + \cos^2 b + \cos^2 g = 1$$

$$\cos^2 a + \cos^2 30^\circ + \cos^2 75^\circ = 1$$

$$a = 64.67^\circ$$

$$F_x = 3 \cos 64.67^\circ = 1.28 \text{ kN}$$

$$F_y = 3 \cos 30^\circ = 2.60 \text{ kN}$$

$$F_z = 3 \cos 75^\circ = 0.776 \text{ kN}$$

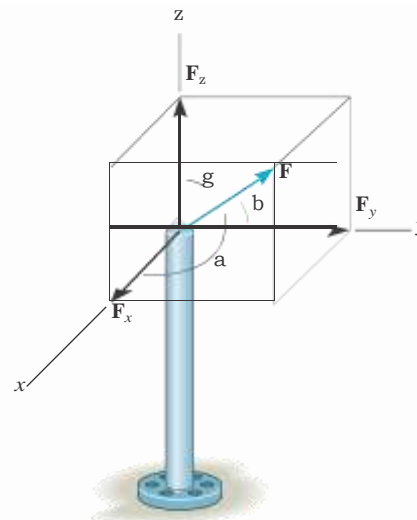

Ans.

Ans.

Ans.

Ans:

$$F_x = 1.28 \text{ kN}$$

$$F_y = 2.60 \text{ kN}$$

$$F_z = 0.776 \text{ kN}$$

2-85.

The pole is subjected to the force \mathbf{F} which has components $F_x = 1.5$ kN and $F_z = 1.25$ kN. If $\theta = 75^\circ$, determine the magnitudes of \mathbf{F} and F_y .

SOLUTION

$$\cos^2 a + \cos^2 b + \cos^2 g = 1$$

$$a \frac{1.5}{F} b^2 + \cos^2 75^\circ + a \frac{1.25}{F} b^2 = 1$$

$$F = 2.02 \text{ kN}$$

Ans.

$$F_y = 2.02 \cos 75^\circ = 0.523 \text{ kN}$$

Ans.

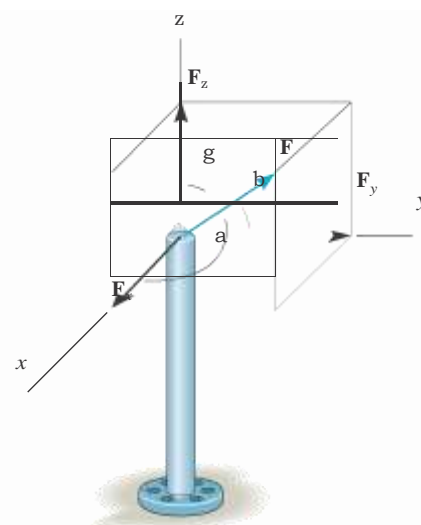

Ans:
 $F = 2.02$ kN, $F_y = 0.523$ kN

2-86.

Determine the lengths of wires AD , BD , and CD . The ring at D is midway between A and B .

SOLUTION

$$D \text{ a } \frac{2+0}{2}, \frac{0+2}{2}, \frac{1.5+0.5}{2} \text{ b m} = D(1, 1, 1) \text{ m}$$

$$\begin{aligned} \mathbf{r}_{AD} &= (1 - 2)\mathbf{i} + (1 - 0)\mathbf{j} + (1 - 1.5)\mathbf{k} \\ &= -1\mathbf{i} + 1\mathbf{j} - 0.5\mathbf{k} \end{aligned}$$

$$\begin{aligned} \mathbf{r}_{BD} &= (1 - 0)\mathbf{i} + (1 - 2)\mathbf{j} + (1 - 0.5)\mathbf{k} \\ &= 1\mathbf{i} - 1\mathbf{j} + 0.5\mathbf{k} \end{aligned}$$

$$\begin{aligned} \mathbf{r}_{CD} &= (1 - 0)\mathbf{i} + (1 - 0)\mathbf{j} + (1 - 2)\mathbf{k} \\ &= 1\mathbf{i} + 1\mathbf{j} - 1\mathbf{k} \end{aligned}$$

$$r_{AD} = \sqrt{(-1)^2 + 1^2 + (-0.5)^2} = 1.50 \text{ m}$$

$$r_{BD} = \sqrt{1^2 + (-1)^2 + 0.5^2} = 1.50 \text{ m}$$

$$r_{CD} = \sqrt{1^2 + 1^2 + (-1)^2} = 1.73 \text{ m}$$

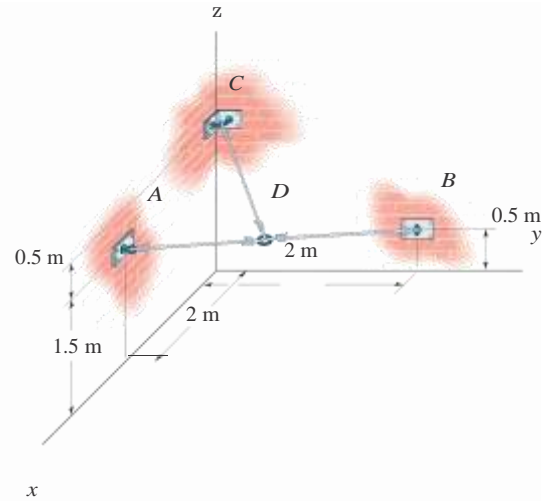

Ans.

Ans.

Ans.

Ans:

$$\begin{aligned}r_{AD} &= 1.50 \text{ m} \\r_{BD} &= 1.50 \text{ m} \\r_{CD} &= 1.73 \text{ m}\end{aligned}$$

2-87.

Determine the length of the connecting rod AB by first formulating a Cartesian position vector from A to B and then determining its magnitude.

Solution

Position Vector. The coordinates of points A and B are $A(-150 \cos 30^\circ, -150 \sin 30^\circ)$ mm and $B(0, 300)$ mm respectively. Then

$$\mathbf{r}_{AB} = [0 - (-150 \cos 30^\circ)]\mathbf{i} + [300 - (-150 \sin 30^\circ)]\mathbf{j}$$

$$= \{129.90\mathbf{i} + 375\mathbf{j}\} \text{ mm}$$

Thus, the magnitude of \mathbf{r}_{AB} is

$$r_{AB} = \sqrt{129.90^2 + 375^2} = 396.86 \text{ mm} = 397 \text{ mm}$$

Ans.

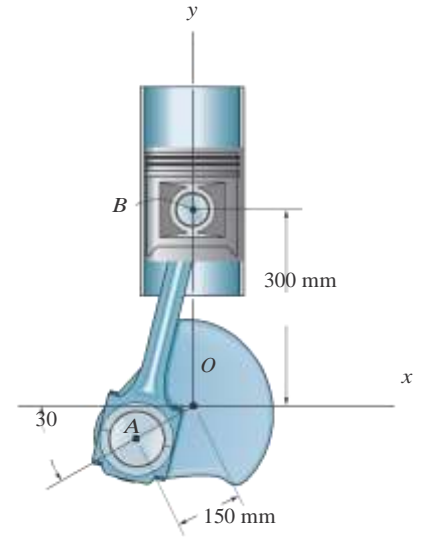

Ans:
 $r_{AB} = 397 \text{ mm}$

*2-88.

If $\mathbf{F} = 5350\mathbf{i} - 250\mathbf{j} - 450\mathbf{k}$ N and cable AB is 9 m long, determine the x , y , z coordinates of point A.

SOLUTION

Position Vector: The position vector \mathbf{r}_{AB} , directed from point A to point B, is given by

$$\begin{aligned}\mathbf{r}_{AB} &= [0 - (-x)]\mathbf{i} + (0 - y)\mathbf{j} + (0 - z)\mathbf{k} \\ &= x\mathbf{i} - y\mathbf{j} - z\mathbf{k}\end{aligned}$$

Unit Vector: Knowing the magnitude of \mathbf{r}_{AB} is 9 m, the unit vector for \mathbf{r}_{AB} is given by

$$\mathbf{u}_{AB} = \frac{\mathbf{r}_{AB}}{r_{AB}} = \frac{x\mathbf{i} - y\mathbf{j} - z\mathbf{k}}{9}$$

The unit vector for force \mathbf{F} is

$$\mathbf{u}_F = \frac{\mathbf{F}}{F} = \frac{350\mathbf{i} - 250\mathbf{j} - 450\mathbf{k}}{\sqrt{350^2 + (-250)^2 + (-450)^2}} = 0.5623\mathbf{i} - 0.4016\mathbf{j} - 0.7229\mathbf{k}$$

Since force \mathbf{F} is also directed from point A to point B, then

$$\mathbf{u}_{AB} = \mathbf{u}_F$$

$$\frac{x\mathbf{i} - y\mathbf{j} - z\mathbf{k}}{9} = 0.5623\mathbf{i} - 0.4016\mathbf{j} - 0.7229\mathbf{k}$$

Equating the \mathbf{i} , \mathbf{j} , and \mathbf{k} components,

$$\frac{x}{9} = 0.5623 \qquad x = 5.06 \text{ m} \qquad \text{Ans.}$$

$$\frac{-y}{9} = -0.4016 \qquad y = 3.61 \text{ m} \qquad \text{Ans.}$$

$$\frac{-z}{9} = 0.7229 \qquad z = 6.51 \text{ m} \qquad \text{Ans.}$$

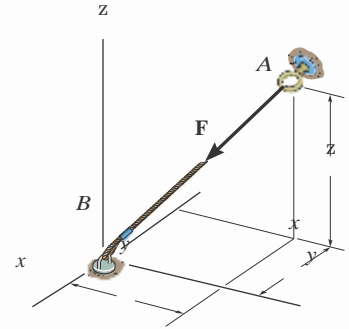

Ans:

$$x = 5.06 \text{ m}$$

$$y = 3.61 \text{ m}$$

$$z = 6.51 \text{ m}$$

2-89.

Determine the magnitude and coordinate direction angles of the resultant force acting at A.

SOLUTION

Force Vectors: The unit vectors \mathbf{u}_B and \mathbf{u}_C of \mathbf{F}_B and \mathbf{F}_C must be determined first. From Fig. a

$$\mathbf{u}_B = \frac{\mathbf{r}_B}{r_B} = \frac{(-1.5 - 0.5)\mathbf{i} + [-2.5 - (-1.5)]\mathbf{j} + (2 - 0)\mathbf{k}}{\sqrt{(-1.5 - 0.5)^2 + [-2.5 - (-1.5)]^2 + (2 - 0)^2}}$$

$$= -\frac{2}{3}\mathbf{i} - \frac{1}{3}\mathbf{j} + \frac{2}{3}\mathbf{k}$$

$$\mathbf{u}_C = \frac{\mathbf{r}_C}{r_C} = \frac{(-1.5 - 0.5)\mathbf{i} + [0.5 - (-1.5)]\mathbf{j} + (3.5 - 0)\mathbf{k}}{\sqrt{(-1.5 - 0.5)^2 + [0.5 - (-1.5)]^2 + (3.5 - 0)^2}}$$

$$= -\frac{4}{9}\mathbf{i} + \frac{4}{9}\mathbf{j} + \frac{7}{9}\mathbf{k}$$

Thus, the force vectors \mathbf{F}_B and \mathbf{F}_C are given by

$$\mathbf{F}_B = F_B \mathbf{u}_B = 600\mathbf{a} - \frac{2}{3}\mathbf{i} - \frac{1}{3}\mathbf{j} + \frac{2}{3}\mathbf{k} = 5 - 400\mathbf{i} - 200\mathbf{j} + 400\mathbf{k} \text{ N}$$

$$\mathbf{F}_C = F_C \mathbf{u}_C = 450\mathbf{a} - \frac{4}{9}\mathbf{i} + \frac{4}{9}\mathbf{j} + \frac{7}{9}\mathbf{k} = 5 - 200\mathbf{i} + 200\mathbf{j} + 350\mathbf{k} \text{ N}$$

Resultant Force:

$$\mathbf{F}_R = \mathbf{F}_B + \mathbf{F}_C = (-400\mathbf{i} - 200\mathbf{j} + 400\mathbf{k}) + (-200\mathbf{i} + 200\mathbf{j} + 350\mathbf{k})$$

$$= 5 - 600\mathbf{i} + 750\mathbf{k} \text{ N}$$

The magnitude of \mathbf{F}_R is _____

$$F_R = \sqrt{(F_R)_x^2 + (F_R)_y^2 + (F_R)_z^2}$$

$$= \sqrt{(-600)^2 + 0^2 + 750^2} = 960.47 \text{ N} = 960 \text{ N}$$

The coordinate direction angles of \mathbf{F}_R are

$$a = \cos^{-1} \frac{(F_R)_x}{F_R} = \cos^{-1} \frac{-600}{960.47} \quad b = 129^\circ$$

Ans.

$$b = \cos^{-1} \frac{(F_R)_y}{F_R} = \cos^{-1} \frac{0}{960.47} \quad b = 90^\circ$$

Ans.

$$g = \cos^{-1} \frac{(F_R)_z}{F_R} = \cos^{-1} \frac{750}{960.47} \quad b = 38.7^\circ$$

Ans.

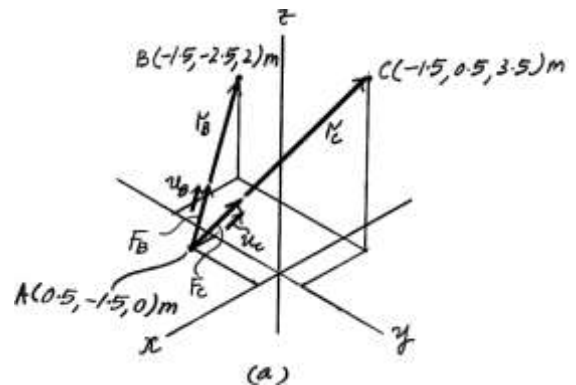
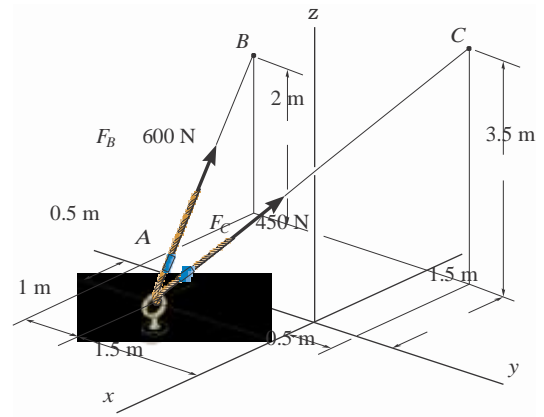

Ans:

a = 129
b = 90
g = 38.7

2-90. The door is held opened by means of two chains. If the tension in AB and CD is $F_A = 300$ N and $F_C = 250$ N, respectively, express each of these forces in Cartesian vector form.

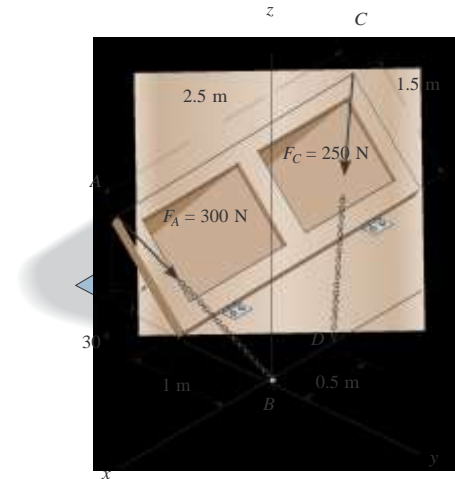

Solution

Unit Vector: First determine the position vector \mathbf{r}_{AB} and \mathbf{r}_{CD} . The coordinates of points A and C are

$$A[30, -(1 + 1.5 \cos 30^\circ), 1.5 \sin 30^\circ] \text{ m} = A(0, -2.299, 0.750) \text{ m}$$

$$C[-2.50, -(1 + 1.5 \cos 30^\circ), 1.5 \sin 30^\circ] \text{ m} = C(-2.50, -2.299, 0.750) \text{ m}$$

Then

$$\begin{aligned} \mathbf{r}_{AB} &= 5(0 - 0)\mathbf{i} + 30 - (-2.299)\mathbf{j} + (0 - 0.750)\mathbf{k} \text{ m} \\ &= 5(2.299\mathbf{j} - 0.750\mathbf{k}) \text{ m} \end{aligned}$$

$$r_{AB} = \sqrt{2(2.299)^2 + (-0.750)^2} = 2.418 \text{ m}$$

$$\mathbf{u}_{AB} = \frac{\mathbf{r}_{AB}}{r_{AB}} = \frac{2.299\mathbf{j} - 0.750\mathbf{k}}{2.418} = 0.9507\mathbf{j} - 0.3101\mathbf{k}$$

$$\begin{aligned} \mathbf{r}_{CD} &= 5[-0.5 - (-2.5)]\mathbf{i} + 30 - (-2.299)\mathbf{j} + (0 - 0.750)\mathbf{k} \text{ m} \\ &= 5(2.00\mathbf{i} + 2.299\mathbf{j} - 0.750\mathbf{k}) \text{ m} \end{aligned}$$

$$r_{CD} = \sqrt{2(2.00)^2 + 2.299^2 + (-0.750)^2} = 3.318 \text{ m}$$

$$\mathbf{u}_{CD} = \frac{\mathbf{r}_{CD}}{r_{CD}} = \frac{2.00\mathbf{i} + 2.299\mathbf{j} - 0.750\mathbf{k}}{3.318} = 0.6373\mathbf{i} + 0.7326\mathbf{j} - 0.2390\mathbf{k}$$

Force Vector:

$$\begin{aligned} \mathbf{F}_A &= F_A \mathbf{u}_{AB} = 300(0.9507\mathbf{j} - 0.3101\mathbf{k}) \text{ N} \\ &= 5285.21\mathbf{j} - 93.04\mathbf{k} \text{ N} \\ &= 5285\mathbf{j} - 93.0\mathbf{k} \text{ N} \end{aligned}$$

Ans.

$$\begin{aligned} \mathbf{F}_C &= F_C \mathbf{u}_{CD} = 250(0.6373\mathbf{i} + 0.7326\mathbf{j} - 0.2390\mathbf{k}) \text{ N} \\ &= 5159.33\mathbf{i} + 183.15\mathbf{j} - 59.75\mathbf{k} \text{ N} \\ &= 5159\mathbf{i} + 183\mathbf{j} - 59.7\mathbf{k} \text{ N} \end{aligned}$$

Ans.

Ans:

$$\mathbf{F}_A = \{285\mathbf{j} - 93.0\mathbf{k}\} \text{ N}$$

$$\mathbf{F}_C = \{159\mathbf{i} + 183\mathbf{j} - 59.7\mathbf{k}\} \text{ N}$$

2-91.

If $F_B = 560 \text{ N}$ and $F_C = 700 \text{ N}$, determine the magnitude and coordinate direction angles of the resultant force acting on the flag pole.

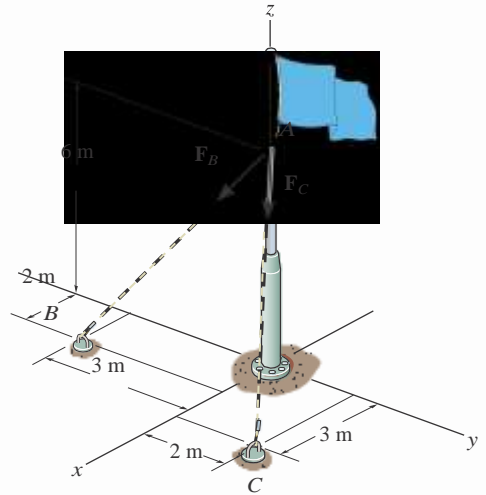

SOLUTION

Force Vectors: The unit vectors \mathbf{u}_B and \mathbf{u}_C of \mathbf{F}_B and \mathbf{F}_C must be determined first. From Fig. a

$$\mathbf{u}_B = \frac{\mathbf{r}_B}{r_B} = \frac{(2-0)\mathbf{i} + (-3-0)\mathbf{j} + (0-6)\mathbf{k}}{\sqrt{(2-0)^2 + (-3-0)^2 + (0-6)^2}} = \frac{2}{7}\mathbf{i} - \frac{3}{7}\mathbf{j} - \frac{6}{7}\mathbf{k}$$

$$\mathbf{u}_C = \frac{\mathbf{r}_C}{r_C} = \frac{(3-0)\mathbf{i} + (2-0)\mathbf{j} + (0-6)\mathbf{k}}{\sqrt{(3-0)^2 + (2-0)^2 + (0-6)^2}} = \frac{3}{7}\mathbf{i} + \frac{2}{7}\mathbf{j} - \frac{6}{7}\mathbf{k}$$

Thus, the force vectors \mathbf{F}_B and \mathbf{F}_C are given by

$$\mathbf{F}_B = F_B \mathbf{u}_B = 560 \left(\frac{2}{7}\mathbf{i} - \frac{3}{7}\mathbf{j} - \frac{6}{7}\mathbf{k} \right) = \{ 160\mathbf{i} - 240\mathbf{j} - 480\mathbf{k} \} \text{ N}$$

$$\mathbf{F}_C = F_C \mathbf{u}_C = 700 \left(\frac{3}{7}\mathbf{i} + \frac{2}{7}\mathbf{j} - \frac{6}{7}\mathbf{k} \right) = \{ 300\mathbf{i} + 200\mathbf{j} - 600\mathbf{k} \} \text{ N}$$

Resultant Force =

$$\mathbf{F}_R = \mathbf{F}_B + \mathbf{F}_C = (160\mathbf{i} - 240\mathbf{j} - 480\mathbf{k}) + (300\mathbf{i} + 200\mathbf{j} - 600\mathbf{k})$$

The magnitude of \mathbf{F}_R is

$$F_R = \sqrt{F_{R_x}^2 + F_{R_y}^2 + F_{R_z}^2} = \sqrt{(460)^2 + (-40)^2 + (-1080)^2} = 1174.56 \text{ N} = 1.17 \text{ kN}$$

The coordinate direction angles of \mathbf{F}_R are

$$\alpha = \cos^{-1} \left(\frac{F_{R_x}}{F_R} \right) = \cos^{-1} \left(\frac{460}{1174.56} \right) = 66.9^\circ$$

$$\beta = \cos^{-1} \left(\frac{F_{R_y}}{F_R} \right) = \cos^{-1} \left(\frac{-40}{1174.56} \right) = 92.0^\circ$$

$$\gamma = \cos^{-1} \left(\frac{F_{R_z}}{F_R} \right) = \cos^{-1} \left(\frac{-1080}{1174.56} \right) = 157^\circ$$

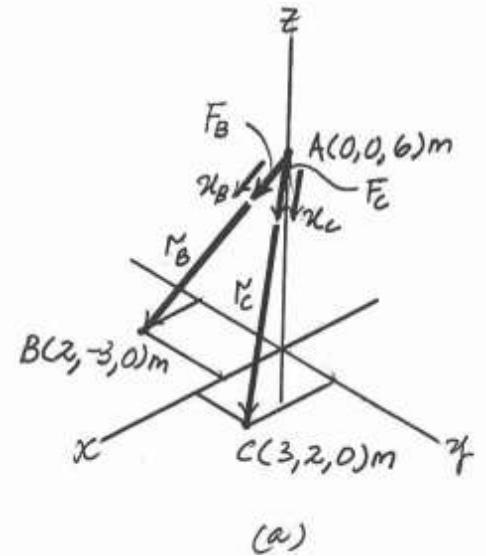

Ans.

Ans.

Ans.

Ans.

Ans:

$$F_R = 1.17 \text{ kN}$$

$$a = 66.9$$

$$b = 92.0$$

$$g = 157$$

*2-92.

If $F = 700$ N, and $F_C = 560$ N, determine the magnitude and coordinate direction angles of the resultant force acting on the flag pole.

SOLUTION

Force Vectors: The unit vectors \mathbf{u} and \mathbf{u}_C of \mathbf{F} and \mathbf{F}_C must be determined first. From Fig. *a*

$$\mathbf{u} = \frac{\mathbf{r}}{r} = \frac{(2-0)\mathbf{i} + (-3-0)\mathbf{j} + (0-6)\mathbf{k}}{\sqrt{(2-0)^2 + (-3-0)^2 + (0-6)^2}} = \frac{2}{7}\mathbf{i} - \frac{3}{7}\mathbf{j} - \frac{6}{7}\mathbf{k}$$

$$\mathbf{u}_C = \frac{\mathbf{r}_C}{r_C} = \frac{(3-0)\mathbf{i} + (2-0)\mathbf{j} + (0-6)\mathbf{k}}{\sqrt{(3-0)^2 + (2-0)^2 + (0-6)^2}} = \frac{3}{7}\mathbf{i} + \frac{2}{7}\mathbf{j} - \frac{6}{7}\mathbf{k}$$

Thus, the force vectors \mathbf{F} and \mathbf{F}_C are given by

$$\mathbf{F} = F \mathbf{u} = 700 \left(\frac{2}{7}\mathbf{i} - \frac{3}{7}\mathbf{j} - \frac{6}{7}\mathbf{k} \right) = \{200\mathbf{i} - 300\mathbf{j} - 600\mathbf{k}\} \text{ N}$$

$$\mathbf{F}_C = F_C \mathbf{u}_C = 560 \left(\frac{3}{7}\mathbf{i} + \frac{2}{7}\mathbf{j} - \frac{6}{7}\mathbf{k} \right) = \{240\mathbf{i} + 160\mathbf{j} - 480\mathbf{k}\} \text{ N}$$

Resultant Force:

$$\begin{aligned} \mathbf{F}_R &= \mathbf{F} + \mathbf{F}_C = (200\mathbf{i} - 300\mathbf{j} - 600\mathbf{k}) + (240\mathbf{i} + 160\mathbf{j} - 480\mathbf{k}) \\ &= \{440\mathbf{i} - 140\mathbf{j} - 1080\mathbf{k}\} \text{ N} \end{aligned}$$

The magnitude of \mathbf{F} is

$$\begin{aligned} F_R &= \sqrt{F_{R_x}^2 + F_{R_y}^2 + F_{R_z}^2} \\ &= \sqrt{(440)^2 + (-140)^2 + (-1080)^2} = 1174.56 \text{ N} = 1.17 \text{ kN} \end{aligned}$$

The coordinate direction angles of \mathbf{F} are

$$\alpha = \cos^{-1} \left[\frac{F_{R_x}}{F_R} \right] = \cos^{-1} \left(\frac{440}{1174.56} \right) = 68.0^\circ$$

$$\beta = \cos^{-1} \left[\frac{F_{R_y}}{F_R} \right] = \cos^{-1} \left(\frac{-140}{1174.56} \right) = 96.8^\circ$$

$$\gamma = \cos^{-1} \left[\frac{F_{R_z}}{F_R} \right] = \cos^{-1} \left(\frac{-1080}{1174.56} \right) = 157^\circ$$

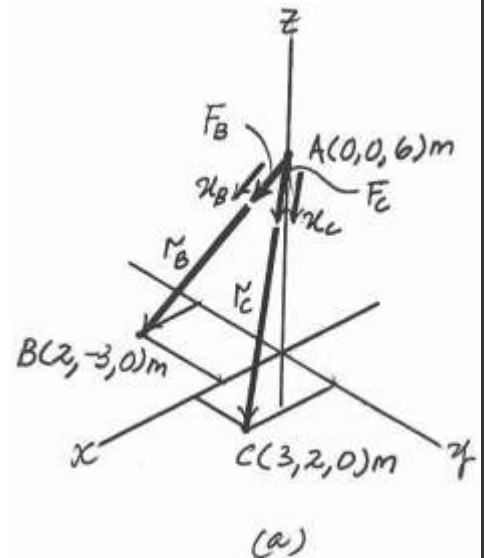
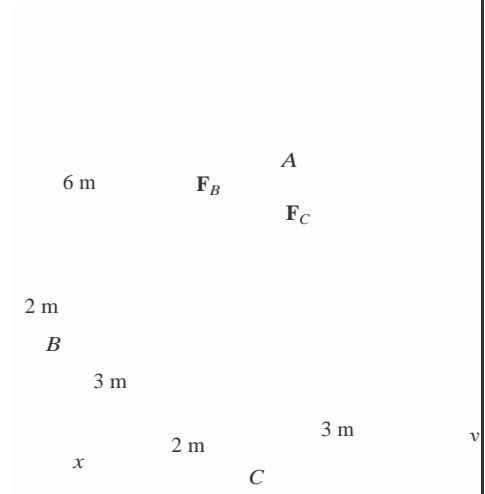

Ans.

Ans.

Ans.

Ans.

Ans:

$F_R = 1.17$ kN

$\alpha = 68.0$

$\beta = 96.8$

$\gamma = 157$

2-93.

Express each of the forces in Cartesian vector form and determine the magnitude and coordinate direction angles of the resultant force.

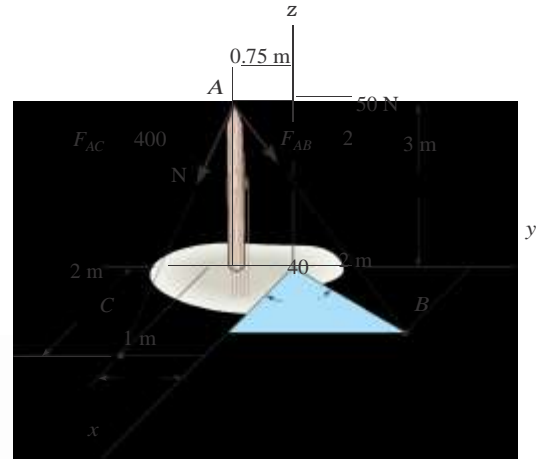

Solution

Unit Vectors. The coordinates for points A, B and C are $(0, -0.75, 3)$ m, $B(2 \cos 40^\circ, 2 \sin 40^\circ, 0)$ m and $C(2, -1, 0)$ m respectively.

$$\begin{aligned} \mathbf{u}_{AB} &= \frac{\mathbf{r}_{AB}}{r_{AB}} = \frac{(2 \cos 40^\circ - 0)\mathbf{i} + [2 \sin 40^\circ - (-0.75)]\mathbf{j} + (0 - 3)\mathbf{k}}{\sqrt{(2 \cos 40^\circ - 0)^2 + [2 \sin 40^\circ - (-0.75)]^2 + (0 - 3)^2}} \\ &= 0.3893\mathbf{i} + 0.5172\mathbf{j} - 0.7622\mathbf{k} \end{aligned}$$

$$\begin{aligned} \mathbf{u}_{AC} &= \frac{\mathbf{r}_{AC}}{r_{AC}} = \frac{(2 - 0)\mathbf{i} + [-1 - (-0.75)]\mathbf{j} + (0 - 3)\mathbf{k}}{\sqrt{(2 - 0)^2 + [-1 - (-0.75)]^2 + (0 - 3)^2}} \\ &= 0.5534\mathbf{i} - 0.0692\mathbf{j} - 0.8301\mathbf{k} \end{aligned}$$

Force Vectors

$$\begin{aligned} \mathbf{F}_{AB} &= F_{AB} \mathbf{u}_{AB} = 250(0.3893\mathbf{i} + 0.5172\mathbf{j} - 0.7622\mathbf{k}) \\ &= \{97.32\mathbf{i} + 129.30\mathbf{j} - 190.56\mathbf{k}\} \text{ N} \\ &= \{97.3\mathbf{i} + 129\mathbf{j} - 191\mathbf{k}\} \text{ N} \end{aligned}$$

Ans.

$$\begin{aligned} \mathbf{F}_{AC} &= F_{AC} \mathbf{u}_{AC} = 400(0.5534\mathbf{i} - 0.06917\mathbf{j} - 0.8301\mathbf{k}) \\ &= \{221.35\mathbf{i} - 27.67\mathbf{j} - 332.02\mathbf{k}\} \text{ N} \\ &= \{221\mathbf{i} - 27.7\mathbf{j} - 332\mathbf{k}\} \text{ N} \end{aligned}$$

Ans.

Resultant Force

$$\begin{aligned} \mathbf{F}_R &= \mathbf{F}_{AB} + \mathbf{F}_{AC} \\ &= \{97.32\mathbf{i} + 129.30\mathbf{j} - 190.56\mathbf{k}\} + \{221.35\mathbf{i} - 27.67\mathbf{j} - 332.02\mathbf{k}\} \\ &= \{318.67\mathbf{i} + 101.63\mathbf{j} - 522.58\mathbf{k}\} \text{ N} \end{aligned}$$

The magnitude of \mathbf{F}_R is

$$\begin{aligned} F_R &= \sqrt{(F_R)_x^2 + (F_R)_y^2 + (F_R)_z^2} = \sqrt{318.67^2 + 101.63^2 + (-522.58)^2} \\ &= 620.46 \text{ N} = 620 \text{ N} \end{aligned}$$

And its coordinate direction angles are

$$\cos a = \frac{(F_R)_x}{F_R} = \frac{318.67}{620.46}; \quad a = 59.10^\circ = 59.1^\circ$$

Ans.

$$\cos b = \frac{(F_R)_y}{F_R} = \frac{101.63}{620.46}; \quad b = 80.57^\circ = 80.6^\circ$$

Ans.

$$\mathbf{F}_{AB} = \{97.3\mathbf{i} - 129\mathbf{j} - 191\mathbf{k}\} \text{ N}$$

$$\mathbf{F}_{AC} = \{221\mathbf{i} - 27.7\mathbf{j} - 332\mathbf{k}\} \text{ N}$$

$$\cos g = \frac{(F_R)_z}{F_R} = \frac{-522.58}{620.46}; \quad g = 147.38^\circ = 147^\circ$$

Ans.

$$\begin{aligned} \cos a &= 59.1 \\ \cos b &= 80.6 \\ \cos g &= 147 \end{aligned}$$

2-94.

The 8-m-long cable is anchored to the ground at A . If $x = 4$ m and $y = 2$ m, determine the coordinate z to the highest point of attachment along the column.

Solution

$$\mathbf{r} = (4\mathbf{i} + 2\mathbf{j} + z\mathbf{k}) \text{ m}$$

$$r = \sqrt{(4)^2 + (2)^2 + (z)^2} = 8$$

$$z = 6.63 \text{ m}$$

Ans.

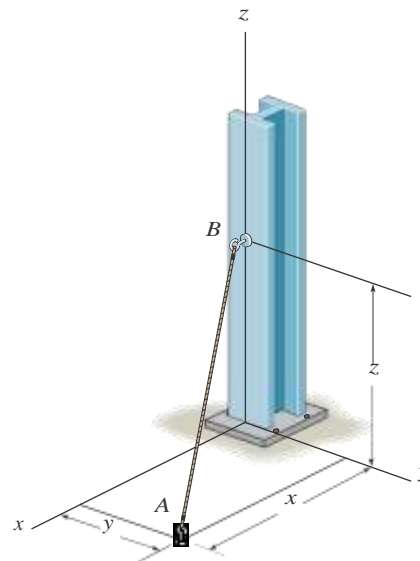

Ans:
6.63 m

2-95.

The 8-m-long cable is anchored to the ground at A . If $z = 5$ m, determine the location $+x, +y$ of point A . Choose a value such that $x = y$.

Solution

$$\mathbf{r} = (x\mathbf{i} + y\mathbf{j} + 5\mathbf{k}) \text{ m}$$

$$r = \sqrt{(x)^2 + (y)^2 + (5)^2} = 8$$

$x = y$, thus

$$2x^2 = 8^2 - 5^2$$

$$x = y = 4.42 \text{ m}$$

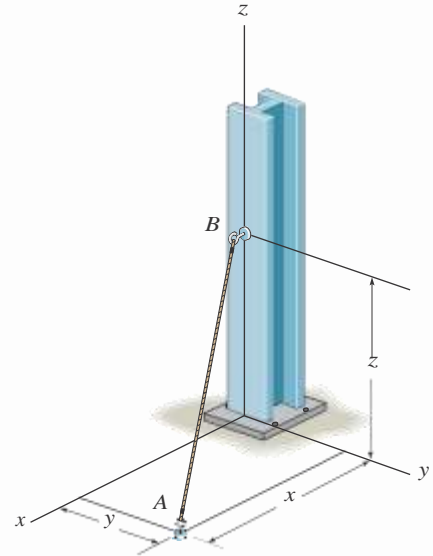

Ans.

Ans:
4.42 m

***2-96.**

Determine the magnitude and coordinate direction angles of the resultant force acting at point A on the post.

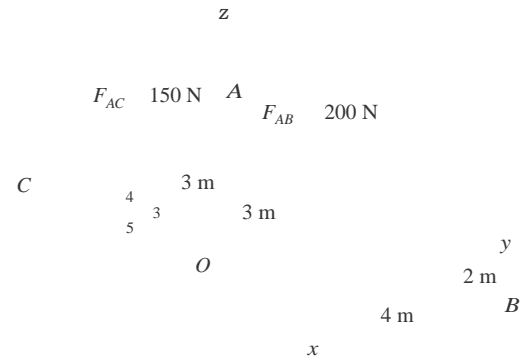

Solution

Unit Vector. The coordinates for points A, B and C are $A(0, 0, 3)$ m, $B(2, 4, 0)$ m and $C(-3, -4, 0)$ m respectively

$$\mathbf{r}_{AB} = (2 - 0)\mathbf{i} + (4 - 0)\mathbf{j} + (0 - 3)\mathbf{k} = (2\mathbf{i} + 4\mathbf{j} - 3\mathbf{k}) \text{ m}$$

$$\mathbf{u}_{AB} = \frac{\mathbf{r}_{AB}}{r_{AB}} = \frac{2\mathbf{i} + 4\mathbf{j} - 3\mathbf{k}}{\sqrt{2^2 + 4^2 + (-3)^2}} = \frac{2}{29}\mathbf{i} + \frac{4}{29}\mathbf{j} - \frac{3}{29}\mathbf{k}$$

$$\mathbf{r}_{AC} = (-3 - 0)\mathbf{i} + (-4 - 0)\mathbf{j} + (0 - 3)\mathbf{k} = (-3\mathbf{i} - 4\mathbf{j} - 3\mathbf{k}) \text{ m}$$

$$\mathbf{u}_{AC} = \frac{\mathbf{r}_{AC}}{r_{AC}} = \frac{-3\mathbf{i} - 4\mathbf{j} - 3\mathbf{k}}{\sqrt{(-3)^2 + (-4)^2 + (-3)^2}} = -\frac{3}{34}\mathbf{i} - \frac{4}{34}\mathbf{j} - \frac{3}{34}\mathbf{k}$$

Force Vectors

$$\begin{aligned} \mathbf{F}_{AB} &= F_{AB} \mathbf{u}_{AB} = 200 \text{ a} \frac{2}{29}\mathbf{i} + \frac{4}{29}\mathbf{j} - \frac{3}{29}\mathbf{k} \text{ b} \\ &= (74.28\mathbf{i} + 148.56\mathbf{j} - 111.42\mathbf{k}) \text{ N} \end{aligned}$$

$$\begin{aligned} \mathbf{F}_{AC} &= F_{AC} \mathbf{u}_{AC} = 150 \text{ a} -\frac{3}{34}\mathbf{i} - \frac{4}{34}\mathbf{j} - \frac{3}{34}\mathbf{k} \text{ b} \\ &= (-77.17\mathbf{i} - 102.90\mathbf{j} - 77.17\mathbf{k}) \text{ N} \end{aligned}$$

Resultant Force

$$\begin{aligned} \mathbf{F}_R &= \mathbf{F}_{AB} + \mathbf{F}_{AC} \\ &= (74.28\mathbf{i} + 148.56\mathbf{j} - 111.42\mathbf{k}) + (-77.17\mathbf{i} - 102.90\mathbf{j} - 77.17\mathbf{k}) \\ &= (-2.896\mathbf{i} + 45.66\mathbf{j} - 188.59\mathbf{k}) \text{ N} \end{aligned}$$

The magnitude of the resultant force is

$$\begin{aligned} F_R &= \sqrt{(F_R)_x^2 + (F_R)_y^2 + (F_R)_z^2} = \sqrt{(-2.896)^2 + 45.66^2 + (-188.59)^2} \\ &= 194.06 \text{ N} = 194 \text{ N} \end{aligned} \quad \text{Ans.}$$

And its coordinate direction angles are

$$\cos a = \frac{(F_R)_x}{F_R} = \frac{-2.896}{194.06}; \quad a = 90.86^\circ = 90.9^\circ \quad \text{Ans.}$$

$$\cos b = \frac{(F_R)_y}{F_R} = \frac{45.66}{194.06}; \quad b = 76.39^\circ = 76.4^\circ \quad \text{Ans.}$$

$$\cos c = \frac{(F_R)_z}{F_R} = \frac{-188.59}{194.06}$$

Ans:

$$\cos g = \frac{F_R}{g} = \frac{194.06}{166.36} = 1.166$$

Ans.

$$\begin{aligned} F_R &= 194 \text{ N} \\ a &= 90.9 \\ b &= 76.4 \\ g &= 166 \end{aligned}$$

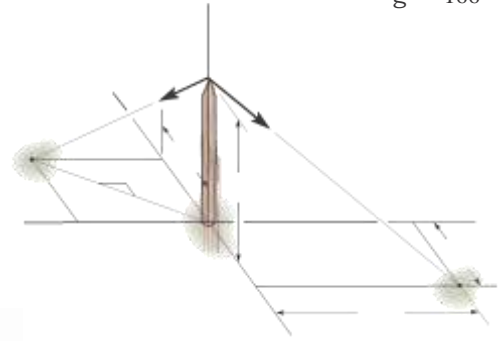

2-97. The cylindrical plate is subjected to the three cable forces which are concurrent at point D . Express each force which the cables exert on the plate as a Cartesian vector, and determine the magnitude and coordinate direction angles of the resultant force.

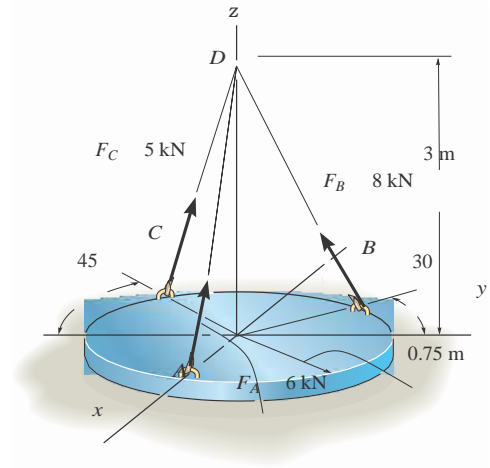

Solution

$$\mathbf{r}_A = (0 - 0.75)\mathbf{i} + (0 - 0)\mathbf{j} + (3 - 0)\mathbf{k} = -0.75\mathbf{i} + 0\mathbf{j} + 3\mathbf{k} \text{ m}$$

$$r_A = \sqrt{(-0.75)^2 + 0^2 + 3^2} = 3.0923 \text{ m}$$

$$\mathbf{F}_A = F_A \frac{\mathbf{r}_A}{r_A} = 6 \text{ a} \frac{-0.75\mathbf{i} + 3\mathbf{k}}{3.0923} \text{ b}$$

$$= 5 - 1.4552\mathbf{i} + 5.8209\mathbf{k} \text{ kN}$$

$$= 5 - 1.46\mathbf{i} + 5.82\mathbf{k} \text{ kN}$$

Ans.

$$\mathbf{r}_C = 30 - (0.75 \sin 45^\circ)\mathbf{i} + 30 - (-0.75 \cos 45^\circ)\mathbf{j} + (3 - 0)\mathbf{k}$$

$$= 50.5303\mathbf{i} + 0.5303\mathbf{j} + 3\mathbf{k} \text{ m}$$

$$r_C = \sqrt{(0.5303)^2 + (0.5303)^2 + 3^2} = 3.0923 \text{ m}$$

$$\mathbf{F}_C = F_C \frac{\mathbf{r}_C}{r_C} = 5 \text{ a} \frac{0.5303\mathbf{i} + 0.5303\mathbf{j} + 3\mathbf{k}}{3.0923} \text{ b}$$

$$= 50.8575\mathbf{i} + 0.8575\mathbf{j} + 4.8507\mathbf{k} \text{ kN}$$

$$= 50.857\mathbf{i} + 0.857\mathbf{j} + 4.85\mathbf{k} \text{ kN}$$

Ans.

$$\mathbf{r}_B = 30 - (0.75 \sin 30^\circ)\mathbf{i} + (0 - 0.75 \cos 30^\circ)\mathbf{j} + (3 - 0)\mathbf{k}$$

$$= 50.375\mathbf{i} - 0.6495\mathbf{j} + 3\mathbf{k} \text{ m}$$

$$r_B = \sqrt{(0.375)^2 + (-0.6495)^2 + 3^2} = 3.0923 \text{ m}$$

$$\mathbf{F}_B = F_B \frac{\mathbf{r}_B}{r_B} = 8 \text{ a} \frac{0.375\mathbf{i} - 0.6495\mathbf{j} + 3\mathbf{k}}{3.0923} \text{ b}$$

$$= 50.9701\mathbf{i} - 1.6803\mathbf{j} + 7.7611\mathbf{k} \text{ kN}$$

$$= 50.970\mathbf{i} - 1.68\mathbf{j} + 7.76\mathbf{k} \text{ kN}$$

Ans.

2-97 (Continued)

$$\mathbf{F}_R = \mathbf{F}_A + \mathbf{F}_B + \mathbf{F}_C$$

$$= 5-1.4552\mathbf{i} + 5.8209\mathbf{k} + 50.9701\mathbf{i} - 1.6803\mathbf{j} + 7.7611\mathbf{k} + 50.8575\mathbf{i} + 0.8575\mathbf{j} + 4.8507\mathbf{k}$$

$$= 50.3724\mathbf{i} - 0.8228\mathbf{j} + 18.4327\mathbf{k} \text{ kN}$$

$$F_R = \sqrt{(0.3724)^2 + (-0.8228)^2 + (18.4327)^2}$$

$$= 18.4548 \text{ kN} = 18.5 \text{ kN}$$

Ans.

$$u_R = \frac{\mathbf{F}_R}{F_R} = \frac{0.3724\mathbf{i} - 0.8228\mathbf{j} + 18.4327\mathbf{k}}{18.4548}$$

$$= 0.02018\mathbf{i} - 0.04459\mathbf{j} + 0.9988\mathbf{k}$$

$$\cos a = 0.02018 \quad a = 88.8$$

Ans.

$$\cos b = -0.04458 \quad b = 92.6$$

Ans.

$$\cos g = 0.9988 \quad g = 2.81$$

Ans.

Ans:

$$\mathbf{F}_A = \{-1.46\mathbf{i} + 5.82\mathbf{k}\} \text{ kN}$$

$$\mathbf{F}_C = \{0.857\mathbf{i} + 0.857\mathbf{j} + 4.85\mathbf{k}\} \text{ kN}$$

$$\mathbf{F}_B = \{0.970\mathbf{i} - 1.68\mathbf{j} + 7.76\mathbf{k}\} \text{ kN}$$

$$F_R = 18.5 \text{ kN}$$

$$a = 88.8$$

$$b = 92.6$$

$$g = 2.81$$

2-98. The cord exerts a force $\mathbf{F} = \{12\mathbf{i} + 9\mathbf{j} - 8\mathbf{k}\}$ kN on the hook. If the cord is 4 m long, determine the location x, y of the point of attachment B , and the height z of the hook.

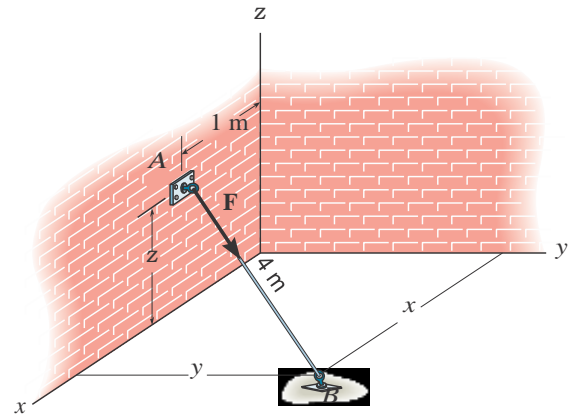

Solution

Given:

$$\mathbf{F} = \begin{bmatrix} 12 \\ 9 \\ -8 \end{bmatrix} \text{ N}$$

$$L = 4 \text{ m}$$

$$a = 1 \text{ m}$$

Initial guesses $x = 1 \text{ m}$ $y = 1 \text{ m}$ $z = 1 \text{ m}$

	x	a		x		x	3.82
Given	y	$= L \frac{ \mathbf{F} }{F}$		$y = \text{Find}(x \ y \ z)$		$y = 2.12 \text{ m}$	Ans.
	z			z		$z = 1.88$	

Ans:
 $x = 3.82 \text{ m}$
 $y = 2.12 \text{ m}$
 $z = 1.88 \text{ m}$

2-99.

The three supporting cables exert the forces shown on the sign. Represent each force as a Cartesian vector.

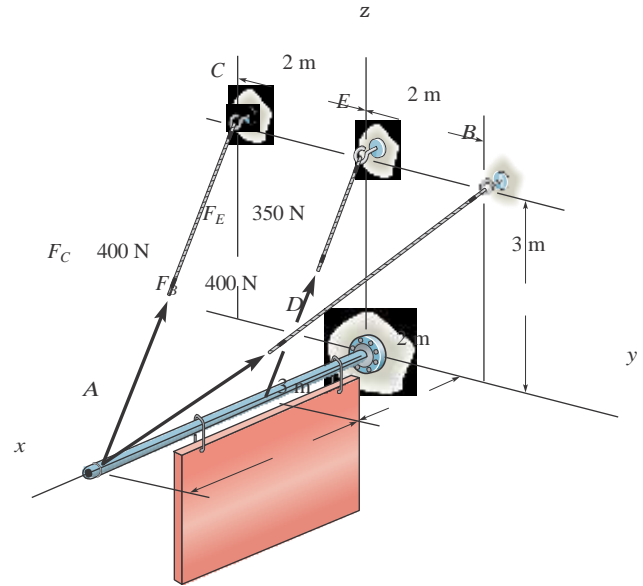

Solution

$$\mathbf{r}_C = (0 - 5)\mathbf{i} + (-2 - 0)\mathbf{j} + (3 - 0)\mathbf{k} = \{-5\mathbf{i} - 2\mathbf{j} + 3\mathbf{k}\} \text{ m}$$

$$r_C = \sqrt{(-5)^2 + (-2)^2 + 3^2} = \sqrt{38} \text{ m}$$

$$\mathbf{r}_B = (0 - 5)\mathbf{i} + (2 - 0)\mathbf{j} + (3 - 0)\mathbf{k} = \{-5\mathbf{i} + 2\mathbf{j} + 3\mathbf{k}\} \text{ m}$$

$$r_B = \sqrt{(-5)^2 + 2^2 + 3^2} = \sqrt{38} \text{ m}$$

$$\mathbf{r}_E = (0 - 2)\mathbf{i} + (0 - 0)\mathbf{j} + (3 - 0)\mathbf{k} = \{-2\mathbf{i} + 0\mathbf{j} + 3\mathbf{k}\} \text{ m}$$

$$r_E = \sqrt{(-2)^2 + 0^2 + 3^2} = \sqrt{13} \text{ m}$$

$$\mathbf{F} = F_{\mathbf{u}} = F \frac{\mathbf{r}}{r}$$

$$\mathbf{F}_C = 400 \text{ a } \frac{-5\mathbf{i} - 2\mathbf{j} + 3\mathbf{k}}{\sqrt{38}} \text{ b} = \{-324\mathbf{i} - 130\mathbf{j} + 195\mathbf{k}\} \text{ N}$$

Ans.

$$\mathbf{F}_B = 400 \text{ a } \frac{-5\mathbf{i} + 2\mathbf{j} + 3\mathbf{k}}{\sqrt{38}} \text{ b} = \{-324\mathbf{i} + 130\mathbf{j} + 195\mathbf{k}\} \text{ N}$$

Ans.

$$\mathbf{F}_E = 350 \text{ a } \frac{-2\mathbf{i} + 0\mathbf{j} + 3\mathbf{k}}{\sqrt{13}} \text{ b} = \{-194\mathbf{i} + 291\mathbf{k}\} \text{ N}$$

Ans.

Ans:

$$\mathbf{F}_C = \{-324\mathbf{i} - 130\mathbf{j} + 195\mathbf{k}\} \text{ N}$$

$$\mathbf{F}_B = \{-324\mathbf{i} + 130\mathbf{j} + 195\mathbf{k}\} \text{ N}$$

$$\mathbf{F}_E = \{-194\mathbf{i} + 291\mathbf{k}\} \text{ N}$$

***2-100.**

Determine the magnitude and coordinate direction angles of the resultant force of the two forces acting on the sign at point A.

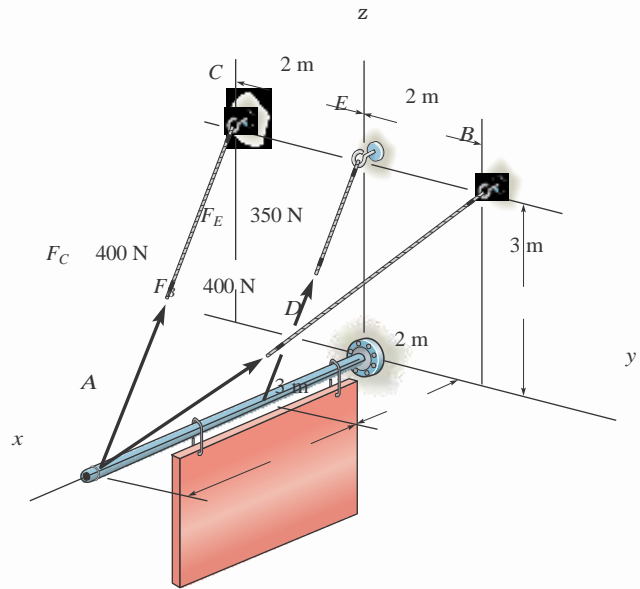

Solution

$$\mathbf{r}_C = (0 - 5)\mathbf{i} + (-2 - 0)\mathbf{j} + (3 - 0)\mathbf{k} = \{-5\mathbf{i} - 2\mathbf{j} + 3\mathbf{k}\}$$

$$r_C = \sqrt{(-5)^2 + (-2)^2 + (3)^2} = \sqrt{38} \text{ m}$$

$$\mathbf{F}_C = 400 \frac{\mathbf{r}_C}{r_C} = 400 \frac{(-5\mathbf{i} - 2\mathbf{j} + 3\mathbf{k})}{\sqrt{38}}$$

$$\mathbf{F}_C = (-324.4428\mathbf{i} - 129.777\mathbf{j} + 194.666\mathbf{k})$$

$$\mathbf{r}_B = (0 - 5)\mathbf{i} + (2 - 0)\mathbf{j} + (3 - 0)\mathbf{k} = \{-5\mathbf{i} + 2\mathbf{j} + 3\mathbf{k}\}$$

$$r_B = \sqrt{(-5)^2 + 2^2 + 3^2} = \sqrt{38} \text{ m}$$

$$\mathbf{F}_B = 400 \frac{\mathbf{r}_B}{r_B} = 400 \frac{(-5\mathbf{i} + 2\mathbf{j} + 3\mathbf{k})}{\sqrt{38}}$$

$$\mathbf{F}_B = (-324.443\mathbf{i} + 129.777\mathbf{j} + 194.666\mathbf{k})$$

$$\mathbf{F}_R = \mathbf{F}_C + \mathbf{F}_B = (-648.89\mathbf{i} + 389.33\mathbf{k})$$

$$F_R = \sqrt{(-648.89)^2 + (389.33)^2 + 0^2} = 756.7242$$

$$F_R = 757 \text{ N}$$

$$a = \cos^{-1} \frac{-648.89}{756.7242} = 149.03 = 149$$

$$b = \cos^{-1} \frac{0}{756.7242} = 90.0$$

$$g = \cos^{-1} \frac{389.33}{756.7242} = 59.036 = 59.0$$

Ans.

Ans.

Ans.

Ans.

Ans:

$$F_R = 757 \text{ N}$$

$$a = 149$$

$$b = 90.0$$

$$g = 59.0$$

2-101. The tower is held in place by three cables. If the force of each cable acting on the tower is shown, determine the magnitude and coordinate direction angles α, β, γ , of the resultant force. Take $x = 20$ m, $y = 15$ m.

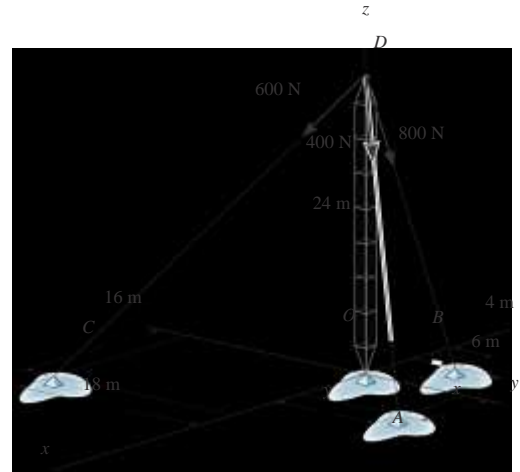

Solution

$$\mathbf{F}_{DA} = 400 \mathbf{a}_{\frac{2}{34.66} \mathbf{i} + \frac{15}{34.66} \mathbf{j} - \frac{24}{34.66} \mathbf{k}} \text{ N}$$

$$\mathbf{F}_{DB} = 800 \mathbf{a}_{\frac{-6}{25.06} \mathbf{i} + \frac{4}{25.06} \mathbf{j} - \frac{24}{25.06} \mathbf{k}} \text{ N}$$

$$\mathbf{F}_{DC} = 600 \mathbf{a}_{\frac{16}{34} \mathbf{i} + \frac{18}{34} \mathbf{j} - \frac{24}{34} \mathbf{k}} \text{ N}$$

$$\begin{aligned} \mathbf{F}_R &= \mathbf{F}_{DA} + \mathbf{F}_{DB} + \mathbf{F}_{DC} \\ &= 5321.66 \mathbf{i} - 16.82 \mathbf{j} - 1466.71 \mathbf{k} \text{ N} \end{aligned}$$

$$\begin{aligned} F_R &= \sqrt{(321.66)^2 + (-16.82)^2 + (-1466.71)^2} \\ &= 1501.66 \text{ N} = 1.50 \text{ kN} \end{aligned}$$

$$\alpha = \cos^{-1} \frac{321.66}{1501.66} \quad \beta = 77.6$$

$$\beta = \cos^{-1} \frac{-16.82}{1501.66} \quad \gamma = 90.6$$

$$\gamma = \cos^{-1} \frac{-1466.71}{1501.66} \quad \alpha = 168$$

Ans.

Ans.

Ans.

Ans.

Ans:
 $F_R = 1.50 \text{ kN}$
 $\alpha = 77.6$
 $\beta = 90.6$
 $\gamma = 168$

2-102.

The guy wires are used to support the telephone pole. Represent the force in each wire in Cartesian vector form. Neglect the diameter of the pole.

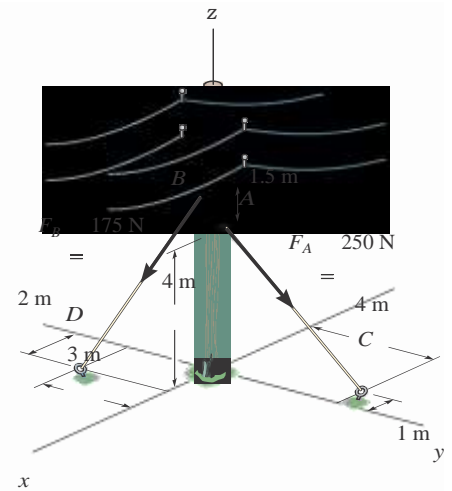

SOLUTION

Unit Vector:

$$\mathbf{r}_{AC} = \{(-1 - 0)\mathbf{i} + (4 - 0)\mathbf{j} + (0 - 4)\mathbf{k}\} \text{ m} = \{-1\mathbf{i} + 4\mathbf{j} - 4\mathbf{k}\} \text{ m}$$

$$r_{AC} = \sqrt{(-1)^2 + 4^2 + (-4)^2} = 5.745 \text{ m}$$

$$\mathbf{u}_{AC} = \frac{\mathbf{r}_{AC}}{r_{AC}} = \frac{-1\mathbf{i} + 4\mathbf{j} - 4\mathbf{k}}{5.745} = -0.1741\mathbf{i} + 0.6963\mathbf{j} - 0.6963\mathbf{k}$$

$$\mathbf{r}_{BD} = \{(2 - 0)\mathbf{i} + (-3 - 0)\mathbf{j} + (0 - 5.5)\mathbf{k}\} \text{ m} = \{2\mathbf{i} - 3\mathbf{j} - 5.5\mathbf{k}\} \text{ m}$$

$$r_{BD} = \sqrt{2^2 + (-3)^2 + (-5.5)^2} = 6.576 \text{ m}$$

$$\mathbf{u}_{BD} = \frac{\mathbf{r}_{BD}}{r_{BD}} = \frac{2\mathbf{i} - 3\mathbf{j} - 5.5\mathbf{k}}{6.576} = 0.3041\mathbf{i} - 0.4562\mathbf{j} - 0.8363\mathbf{k}$$

Force Vector:

$$\begin{aligned} \mathbf{F}_A &= F_A \mathbf{u}_{AC} = 250\{-0.1741\mathbf{i} + 0.6963\mathbf{j} - 0.6963\mathbf{k}\} \text{ N} \\ &= \{-43.52\mathbf{i} + 174.08\mathbf{j} - 174.08\mathbf{k}\} \text{ N} \\ &= \{-43.5\mathbf{i} + 174\mathbf{j} - 174\mathbf{k}\} \text{ N} \end{aligned}$$

Ans.

$$\begin{aligned} \mathbf{F}_B &= F_B \mathbf{u}_{BD} = 175\{0.3041\mathbf{i} - 0.4562\mathbf{j} - 0.8363\mathbf{k}\} \text{ N} \\ &= \{53.22\mathbf{i} - 79.83\mathbf{j} - 146.36\mathbf{k}\} \text{ N} \\ &= \{53.2\mathbf{i} - 79.8\mathbf{j} - 146\mathbf{k}\} \text{ N} \end{aligned}$$

Ans.

Ans:

$$\mathbf{F}_A = \{-43.5\mathbf{i} + 174\mathbf{j} - 174\mathbf{k}\} \text{ N}$$

$$\mathbf{F}_B = \{53.2\mathbf{i} - 79.8\mathbf{j} - 146\mathbf{k}\} \text{ N}$$

2-103.

Determine the magnitude and coordinate direction angles of the resultant force acting at point *A*.

SOLUTION

$$\mathbf{r}_{AC} = \{3\mathbf{i} - 0.5\mathbf{j} - 4\mathbf{k}\} \text{ m}$$

$$|\mathbf{r}_{AC}| = \sqrt{3^2 + (-0.5)^2 + (-4)^2} = \sqrt{25.25} = 5.02494$$

$$\mathbf{F}_2 = 200 \frac{3\mathbf{i} - 0.5\mathbf{j} - 4\mathbf{k}}{5.02494} = (119.4044\mathbf{i} - 19.9007\mathbf{j} - 159.2059\mathbf{k})$$

$$\mathbf{r}_{AB} = (3 \cos 60^\circ \mathbf{i} + (1.5 + 3 \sin 60^\circ)\mathbf{j} - 4\mathbf{k})$$

$$\mathbf{r}_{AB} = (1.5\mathbf{i} + 4.0981\mathbf{j} + 4\mathbf{k})$$

$$|\mathbf{r}_{AB}| = \sqrt{(1.5)^2 + (4.0981)^2 + (-4)^2} = 5.9198$$

$$\mathbf{F}_1 = 150 \frac{1.5\mathbf{i} + 4.0981\mathbf{j} - 4\mathbf{k}}{5.9198} = (38.0079\mathbf{i} + 103.8396\mathbf{j} - 101.3545\mathbf{k})$$

$$\mathbf{F}_R = \mathbf{F}_1 + \mathbf{F}_2 = (157.4124\mathbf{i} + 83.9389\mathbf{j} - 260.5607\mathbf{k})$$

$$F_R = \sqrt{(157.4124)^2 + (83.9389)^2 + (-260.5607)^2} = 315.7786 = 316 \text{ N} \quad \text{Ans.}$$

$$\alpha = \cos^{-1} \frac{157.4124}{315.7786} = 60.100^\circ = 60.1^\circ \quad \text{Ans.}$$

$$\beta = \cos^{-1} \frac{83.9389}{315.7786} = 74.585^\circ = 74.6^\circ \quad \text{Ans.}$$

$$\gamma = \cos^{-1} \frac{-260.5607}{315.7786} = 145.60^\circ = 146^\circ \quad \text{Ans.}$$

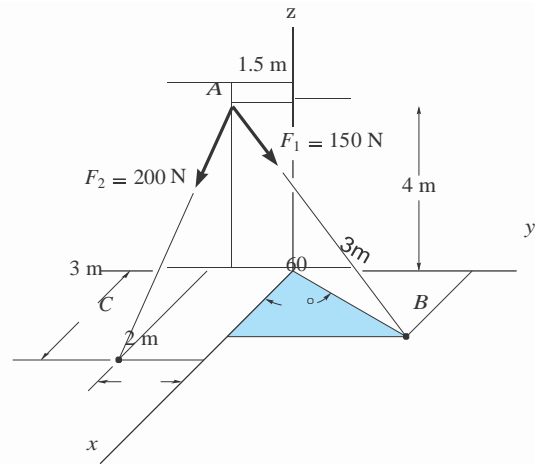

Ans:
 $F_R = 316 \text{ N}$
 $\alpha = 60.1$
 $\beta = 74.6$
 $\gamma = 146$

*2-104. Two cables are used to secure the overhang boom in position and support the 1500-N load. If the resultant force is directed along the boom from point A towards O , determine the magnitudes of the resultant force and forces F_B and F_C . Set $x = 3$ m and $z = 2$ m.

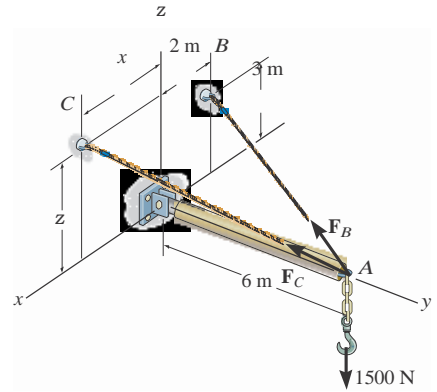

Solution

Force Vectors: The unit vectors u_B and u_C must be determined first. From Fig. a ,

$$u_B = \frac{\underline{r}_B}{r_B} = \frac{(-2 - 0)\mathbf{i} + (0 - 6)\mathbf{j} + (3 - 0)\mathbf{k}}{\sqrt{(-2 - 0)^2 + (0 - 6)^2 + (3 - 0)^2}} = -\frac{2}{7}\mathbf{i} - \frac{6}{7}\mathbf{j} + \frac{3}{7}\mathbf{k}$$

$$u_C = \frac{\underline{r}_C}{r_C} = \frac{(3 - 0)\mathbf{i} + (0 - 6)\mathbf{j} + (2 - 0)\mathbf{k}}{\sqrt{(3 - 0)^2 + (0 - 6)^2 + (2 - 0)^2}} = \frac{3}{7}\mathbf{i} - \frac{6}{7}\mathbf{j} + \frac{2}{7}\mathbf{k}$$

Thus, the force vectors F_B and F_C are given by

$$\underline{F}_B = F_B u_B = -\frac{2}{7}F_B \mathbf{i} - \frac{6}{7}F_B \mathbf{j} + \frac{3}{7}F_B \mathbf{k}$$

$$\underline{F}_C = F_C u_C = \frac{3}{7}F_C \mathbf{i} - \frac{6}{7}F_C \mathbf{j} + \frac{2}{7}F_C \mathbf{k}$$

Since the resultant force F_R is directed along the negative y axis, and the load W is directed along the z axis, these two forces can be written as

$$\underline{F}_R = -F_R \mathbf{j} \quad \text{and} \quad \underline{W} = [-1500\mathbf{k}] \text{ N}$$

Resultant Force: The vector addition of F_B , F_C , and W is equal to F_R . Thus,

$$\begin{aligned} \underline{F}_R &= \underline{F}_B + \underline{F}_C + \underline{W} \\ -F_R \mathbf{j} &= \frac{2}{7}F_B \mathbf{i} - \frac{6}{7}F_B \mathbf{j} + \frac{3}{7}F_B \mathbf{k} + \frac{3}{7}F_C \mathbf{i} - \frac{6}{7}F_C \mathbf{j} + \frac{2}{7}F_C \mathbf{k} + (-1500\mathbf{k}) \\ -F_R \mathbf{j} &= \frac{2}{7}F_B + \frac{3}{7}F_C \mathbf{i} + \frac{3}{7}F_B - \frac{6}{7}F_C \mathbf{j} + \frac{3}{7}F_B + \frac{2}{7}F_C - 1500 \mathbf{k} \end{aligned}$$

Equating the \mathbf{i} , \mathbf{j} , and \mathbf{k} components,

$$0 = -\frac{2}{7}F_B + \frac{3}{7}F_C \quad (1)$$

$$-F_R = -\frac{6}{7}F_B - \frac{6}{7}F_C \quad (2)$$

$$0 = \frac{3}{7}F_B + \frac{2}{7}F_C - 1500 \quad (3)$$

Solving Eqs. (1), (2), and (3) yields

$$F_C = 1615.38 \text{ N} = 1.62 \text{ kN} \quad \text{Ans.}$$

$$F_B = 2423.08 \text{ N} = 2.42 \text{ kN} \quad \text{Ans.}$$

$$F_R = 3461.53 \text{ N} = 3.46 \text{ kN} \quad \text{Ans.}$$

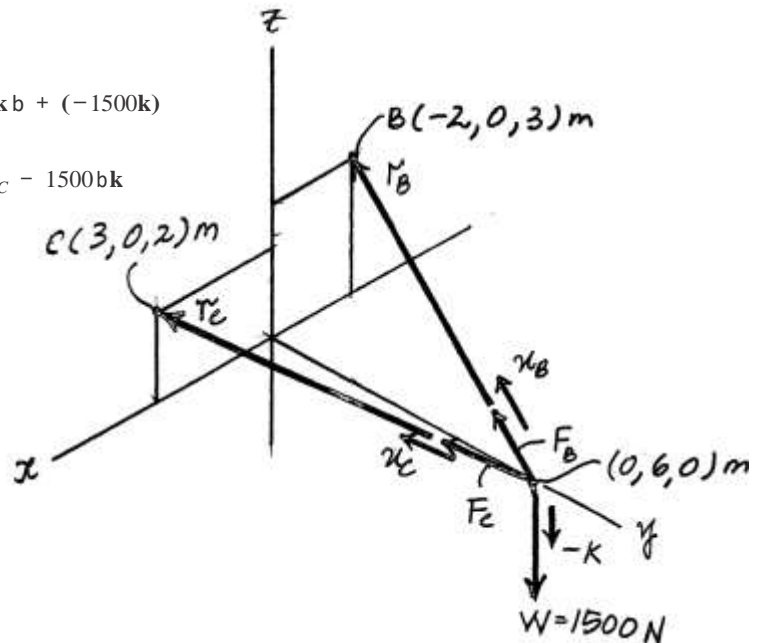

Ans:

$$F_C = 1.62 \text{ kN}$$

$$F_B = 2.42 \text{ kN}$$

$$F_R = 3.46 \text{ kN}$$

2-105. Two cables are used to secure the overhang boom in position and support the 1500-N load. If the resultant force is directed along the boom from point A towards O , determine the values of x and z for the coordinates of point C and the magnitude of the resultant force. Set $F_B = 1610$ N and $F_C = 2400$ N.

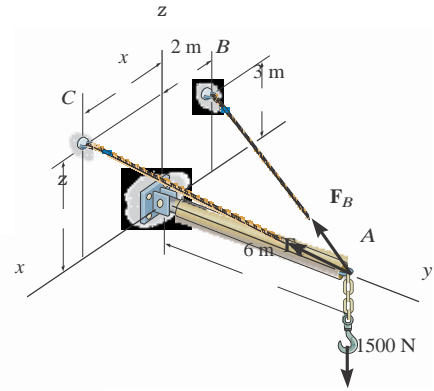

Solution

Force Vectors: From Fig. a ,

$$\mathbf{u}_B = \frac{\mathbf{r}_{B/O}}{r_B} = \frac{(-2 - 0)\mathbf{i} + (0 - 0)\mathbf{j} + (3 - 0)\mathbf{k}}{\sqrt{(-2)^2 + (0)^2 + (3)^2}} = -\frac{2}{7}\mathbf{i} - \frac{0}{7}\mathbf{j} + \frac{3}{7}\mathbf{k}$$

$$\mathbf{u}_C = \frac{\mathbf{r}_{C/O}}{r_C} = \frac{(x - 0)\mathbf{i} + (0 - 0)\mathbf{j} + (z - 0)\mathbf{k}}{\sqrt{x^2 + 0^2 + z^2}} = \frac{x}{\sqrt{x^2 + z^2}}\mathbf{i} - \frac{0}{\sqrt{x^2 + z^2}}\mathbf{j} + \frac{z}{\sqrt{x^2 + z^2}}\mathbf{k}$$

Thus,

$$\mathbf{F}_B = F_B \mathbf{u}_B = 1610 \left[-\frac{2}{7}\mathbf{i} - \frac{0}{7}\mathbf{j} + \frac{3}{7}\mathbf{k} \right] = -460\mathbf{i} - 1380\mathbf{j} + 690\mathbf{k} \text{ N}$$

$$\mathbf{F}_C = F_C \mathbf{u}_C = 2400 \left[\frac{x}{\sqrt{x^2 + z^2}}\mathbf{i} - \frac{0}{\sqrt{x^2 + z^2}}\mathbf{j} + \frac{z}{\sqrt{x^2 + z^2}}\mathbf{k} \right]$$

$$= \frac{2400x}{\sqrt{x^2 + z^2}}\mathbf{i} - \frac{14400}{\sqrt{x^2 + z^2}}\mathbf{j} + \frac{2400z}{\sqrt{x^2 + z^2}}\mathbf{k}$$

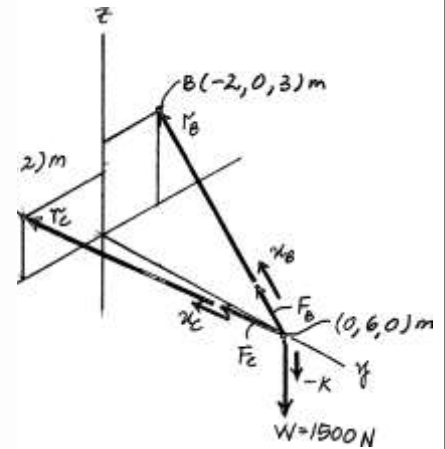

Since the resultant force F_R is directed along the negative y axis, and the load is directed along the z axis, these two forces can be written as

$$\mathbf{F}_R = -F_R \mathbf{j} \quad \text{and} \quad \mathbf{W} = [-1500\mathbf{k}] \text{ N}$$

Resultant Force:

$$\mathbf{F}_R = \mathbf{F}_B + \mathbf{F}_C + \mathbf{W}$$

$$-F_R \mathbf{j} = (-460\mathbf{i} - 1380\mathbf{j} + 690\mathbf{k}) + a \frac{2400x}{\sqrt{x^2 + z^2}}\mathbf{i} - \frac{14400}{\sqrt{x^2 + z^2}}\mathbf{j} + \frac{2400z}{\sqrt{x^2 + z^2}}\mathbf{k} + (-1500\mathbf{k})$$

$$-F_R \mathbf{j} = a \frac{2400x}{\sqrt{x^2 + z^2}}\mathbf{i} - 460\mathbf{i} - a \frac{14400}{\sqrt{x^2 + z^2}}\mathbf{j} + 1380\mathbf{j} + \frac{2400z}{\sqrt{x^2 + z^2}}\mathbf{k} - 1500\mathbf{k}$$

Equating the \mathbf{i} , \mathbf{j} , and \mathbf{k} components,

$$0 = \frac{2400x}{\sqrt{x^2 + z^2}} - 460 \quad \frac{2400x}{\sqrt{x^2 + z^2}} = 460 \quad (1)$$

$$-F_R = -a \frac{14400}{\sqrt{x^2 + z^2}} + 1380 \quad F_R = a \frac{14400}{\sqrt{x^2 + z^2}} + 1380 \quad (2)$$

$$0 = 690 + \frac{2400z}{\sqrt{x^2 + z^2}} - 1500 \quad \frac{2400z}{\sqrt{x^2 + z^2}} = 810 \quad (3)$$

2-105 (Continued)

Dividing Eq. (1) by Eq. (3), yields

$$x = 0.5679 \quad (4)$$

Substituting Eq. (4) into Eq. (1), and solving

$$z = 2.197 \text{ m} = 2.20 \text{ m} \quad \text{Ans.}$$

Substituting $z = 2.197 \text{ m}$ into Eq. (4), yields,

$$x = 1.248 \text{ m} = 1.25 \text{ m} \quad \text{Ans.}$$

Substituting $x = 1.248 \text{ m}$ and $z = 2.197 \text{ m}$ into Eq. (2), yields

$$F_R = 3591.85 \text{ N} = 3.59 \text{ kN} \quad \text{Ans.}$$

$$\begin{aligned} \text{Ans:} \\ Z &= 2.20 \text{ m} \\ X &= 1.25 \text{ m} \\ F_R &= 3.59 \text{ kN} \end{aligned}$$

2-106.

Given the three vectors \mathbf{A} , \mathbf{B} , and \mathbf{D} , show that $\mathbf{A} \cdot (\mathbf{B} + \mathbf{D}) = (\mathbf{A} \cdot \mathbf{B}) + (\mathbf{A} \cdot \mathbf{D})$.

SOLUTION

Since the component of $(\mathbf{B} + \mathbf{D})$ is equal to the sum of the components of \mathbf{B} and \mathbf{D} , then

$$\mathbf{A} \cdot (\mathbf{B} + \mathbf{D}) = \mathbf{A} \cdot \mathbf{B} + \mathbf{A} \cdot \mathbf{D} \quad (\text{QED})$$

Also,

$$\begin{aligned} \mathbf{A} \cdot (\mathbf{B} + \mathbf{D}) &= (A_x \mathbf{i} + A_y \mathbf{j} + A_z \mathbf{k}) \cdot [(B_x + D_x)\mathbf{i} + (B_y + D_y)\mathbf{j} + (B_z + D_z)\mathbf{k}] \\ &= A_x (B_x + D_x) + A_y (B_y + D_y) + A_z (B_z + D_z) \\ &= (A_x B_x + A_y B_y + A_z B_z) + (A_x D_x + A_y D_y + A_z D_z) \\ &= (\mathbf{A} \cdot \mathbf{B}) + (\mathbf{A} \cdot \mathbf{D}) \quad (\text{QED}) \end{aligned}$$

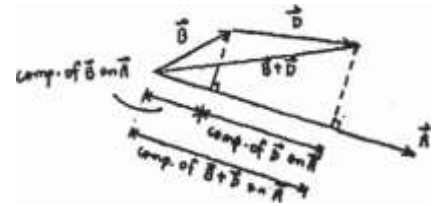

2-107. Determine the design angle u ($0^\circ \dots u \dots 90^\circ$) for strut AB so that the 400-N horizontal force has a component of 500 N directed from A towards C . What is the component of force acting along member AB ? Take $f = 40^\circ$.

Solution

Parallelogram Law: The parallelogram law of addition is shown in Fig. (a).

Trigonometry: Using law of sines [Fig. (b)], we have

$$\frac{\sin u}{500} = \frac{\sin 40^\circ}{400}$$

$$\sin u = 0.8035$$

$$u = 53.46^\circ = 53.5^\circ$$

Thus, $f = 180^\circ - 40^\circ - 53.46^\circ = 86.54^\circ$

Using law of sines [Fig. (b)]

$$\frac{F_{AB}}{\sin 86.54^\circ} = \frac{400}{\sin 40^\circ}$$

$$F_{AB} = 621 \text{ N}$$

400 N A

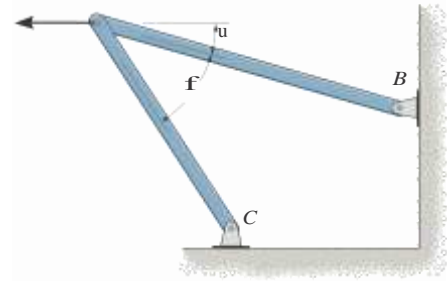

Ans.

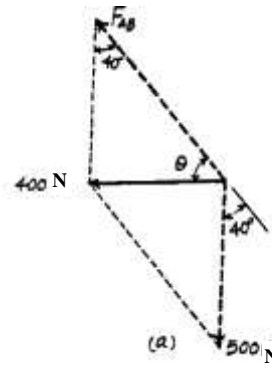

Ans.

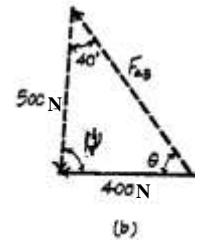

Ans:
 $u = 53.5^\circ$
 $F_{AB} = 621 \text{ N}$

*2-108.

Determine the projection of the force \mathbf{F} along the pole.

SOLUTION

$$\text{Proj } \mathbf{F} = \mathbf{F} \cdot \mathbf{u}_a = 12\mathbf{i} + 4\mathbf{j} + 10\mathbf{k} \cdot \frac{2}{3}\mathbf{i} + \frac{2}{3}\mathbf{j} - \frac{1}{3}\mathbf{k}$$

$$\text{Proj } \mathbf{F} = 0.667 \text{ kN}$$

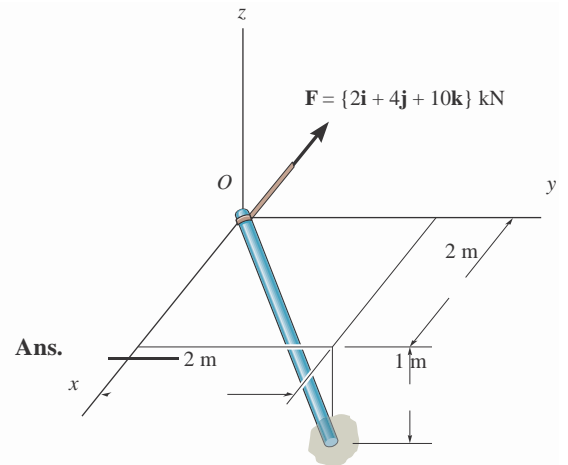

Ans:
Proj $\mathbf{F} = 0.667 \text{ kN}$

2-109.

Determine the angle u between the sides of the triangular plate.

SOLUTION

A

$$\mathbf{r}_{AC} = 5\mathbf{i} + 4\mathbf{j} - 1\mathbf{k} \text{ m}$$

$$\mathbf{r}_{AB} = 2\mathbf{j} + 3\mathbf{k} \text{ m}$$

$$r_{AB} = \sqrt{2^2 + 3^2} = 3.6056 \text{ m}$$

$$\mathbf{r}_{AC} \cdot \mathbf{r}_{AB} = 0 + 4(2) + 1(-3) = 5$$

$$u = \cos^{-1} \left(\frac{\mathbf{r}_{AC} \cdot \mathbf{r}_{AB}}{r_{AC} r_{AB}} \right) = \cos^{-1} \frac{5}{15.0990213.60562}$$

$$u = 74.219^\circ = 74.2^\circ$$

Ans.

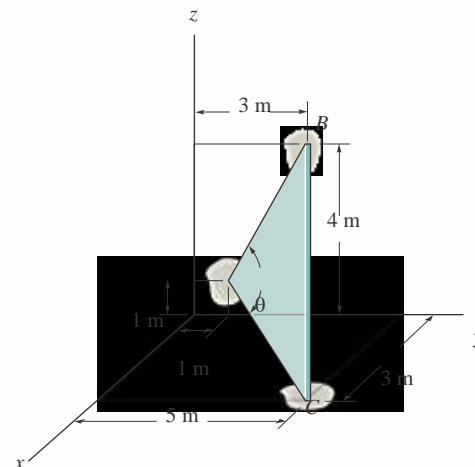

Ans:
 $u = 74.2$

2-110.

Determine the length of side BC of the triangular plate. Solve the problem by finding the magnitude of r_{BC} ; then check the result by first finding θ , r_{AB} , and r_{AC} and then using the cosine law.

SOLUTION

$$r_{BC} = \{3\mathbf{i} + 2\mathbf{j} - 4\mathbf{k}\} \text{ m}$$

$$r_{BC} = \sqrt{2(3)^2 + (2)^2 + (-4)^2} = 5.39 \text{ m}$$

Also,

$$r_{AC} = \{3\mathbf{i} + 4\mathbf{j} - 1\mathbf{k}\} \text{ m}$$

$$r_{AC} = \sqrt{2(3)^2 + (4)^2 + (-1)^2} = 5.0990 \text{ m}$$

$$r_{AB} = \{2\mathbf{j} + 3\mathbf{k}\} \text{ m}$$

$$r_{AB} = \sqrt{2(2)^2 + (3)^2} = 3.6056 \text{ m}$$

$$r_{AC} \cdot r_{AB} = 0 + 4(2) + (-1)(3) = 5$$

$$u = \cos^{-1} \frac{r_{AC} \cdot r_{AB}}{r_{AC} r_{AB}} = \cos^{-1} \frac{5}{(5.0990)(3.6056)}$$

$$u = 74.219^\circ$$

$$r_{BC} = \sqrt{(5.0990)^2 + (3.6056)^2 - 2(5.0990)(3.6056) \cos 74.219^\circ}$$

$$r_{BC} = 5.39 \text{ m}$$

Ans.

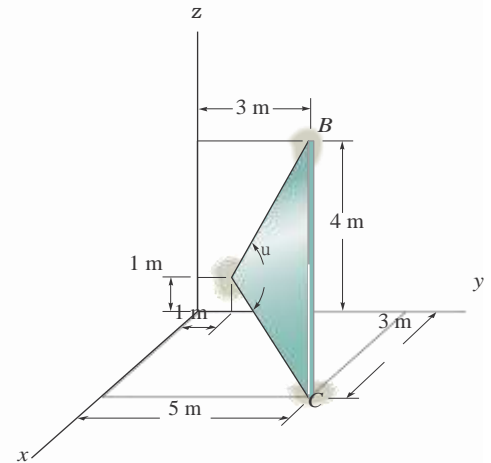

Ans.

Ans:

$$r_{BC} = 5.39 \text{ m}$$

2-111. Determine the magnitude of the projected component of \mathbf{r}_1 along \mathbf{r}_2 , and the projection of \mathbf{r}_2 along \mathbf{r}_1 .

SOLUTION

Given:

$$r_1 = 9 \text{ m}$$

$$r_2 = 6 \text{ m}$$

$$60^\circ$$

$$45^\circ$$

$$120^\circ$$

$$30^\circ$$

$$40^\circ$$

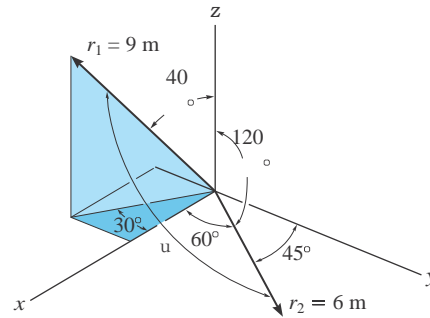

Write the vectors and unit vectors

$$\mathbf{r}_{1v} = r_1 \begin{pmatrix} \sin 40^\circ \cos 30^\circ \\ \sin 40^\circ \sin 30^\circ \\ \cos 40^\circ \end{pmatrix} = \begin{pmatrix} 5.01 \\ 2.89 \\ 6.89 \end{pmatrix} \text{ m}$$

$$\mathbf{r}_{2v} = r_2 \begin{pmatrix} \cos 45^\circ \\ \sin 45^\circ \\ 0 \end{pmatrix} = \begin{pmatrix} 4.24 \\ 4.24 \\ 0 \end{pmatrix} \text{ m}$$

$$\mathbf{u}_1 = \frac{\mathbf{r}_{1v}}{r_1} = \begin{pmatrix} 0.557 \\ 0.321 \\ 0.766 \end{pmatrix}, \quad \mathbf{u}_2 = \frac{\mathbf{r}_{2v}}{r_2} = \begin{pmatrix} 0.5 \\ 0.5 \\ 0 \end{pmatrix}$$

The magnitude of the projection of \mathbf{r}_1 along \mathbf{r}_2 is $|\mathbf{r}_{1v} \cdot \mathbf{u}_2| = 2.99 \text{ m}$ **Ans.**

The magnitude of the projection of \mathbf{r}_2 along \mathbf{r}_1 is $|\mathbf{r}_{2v} \cdot \mathbf{u}_1| = 1.99 \text{ m}$ **Ans.**

Ans:

$$|r_1 \uparrow_2| = 2.99 \text{ m}, |r_2 \uparrow_1| = 1.99 \text{ m}$$

*2-112.

Determine the angle between the two cords.

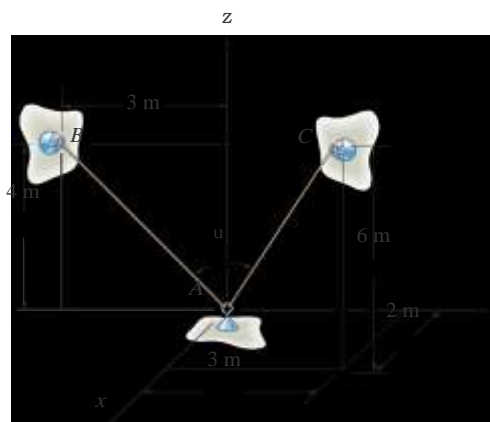

SOLUTION

Given:

$a = 3 \text{ m}$

$b = 2 \text{ m}$

$c = 6 \text{ m}$

$d = 3 \text{ m}$

$e = 4 \text{ m}$

$$\cos \theta = \frac{\mathbf{r}_{AC} \cdot \mathbf{r}_{AB}}{|\mathbf{r}_{AC}| |\mathbf{r}_{AB}|} = \frac{a \cdot d + b \cdot e + c \cdot 0}{\sqrt{a^2 + b^2 + c^2} \sqrt{d^2 + e^2}} = \frac{3 \cdot 3 + 2 \cdot 4 + 6 \cdot 0}{\sqrt{3^2 + 2^2 + 6^2} \sqrt{3^2 + 4^2}} = \frac{17}{\sqrt{49} \sqrt{25}} = \frac{17}{7 \cdot 5} = \frac{17}{35}$$

$\theta = \cos^{-1} \left(\frac{17}{35} \right) = 64.6^\circ$ **Ans.**

Ans:
64.6°

2-113.

Determine the magnitudes of the components of $F = 600 \text{ N}$ acting along and perpendicular to segment DE of the pipe assembly.

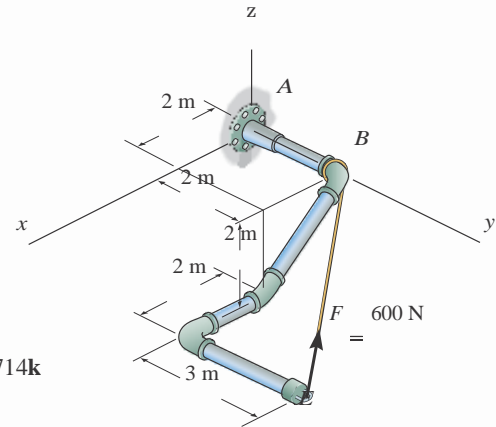

SOLUTION

Unit Vectors: The unit vectors \mathbf{u}_{EB} and \mathbf{u}_{ED} must be determined first. From Fig. *a*,

$$\mathbf{u}_{EB} = \frac{\mathbf{r}_{EB}}{r_{EB}} = \frac{(0 - 4)\mathbf{i} + (2 - 5)\mathbf{j} + [0 - (-2)]\mathbf{k}}{\sqrt{(0 - 4)^2 + (2 - 5)^2 + [0 - (-2)]^2}} = -0.7428\mathbf{i} - 0.5571\mathbf{j} + 0.3714\mathbf{k}$$

$$\mathbf{u}_{ED} = -\mathbf{j}$$

Thus, the force vector \mathbf{F} is given by

$$\mathbf{F} = F\mathbf{u}_{EB} = 600(-0.7428\mathbf{i} - 0.5571\mathbf{j} + 0.3714\mathbf{k}) = [-445.66\mathbf{i} - 334.25\mathbf{j} + 222.83\mathbf{k}] \text{ N}$$

Vector Dot Product: The magnitude of the component of \mathbf{F} parallel to segment DE of the pipe assembly is

$$\begin{aligned} (F_{ED})_{\text{para}} &= \mathbf{F} \cdot \mathbf{u}_{ED} = [-445.66\mathbf{i} - 334.25\mathbf{j} + 222.83\mathbf{k}] \cdot [-\mathbf{j}] \\ &= (-445.66)(0) + (-334.25)(-1) + (222.83)(0) \\ &= 334.25 = 334 \text{ N} \end{aligned} \quad \text{Ans.}$$

The component of \mathbf{F} perpendicular to segment DE of the pipe assembly is

$$(F_{ED})_{\text{per}} = \sqrt{F^2 - (F_{ED})_{\text{para}}^2} = \sqrt{600^2 - 334.25^2} = 498 \text{ N} \quad \text{Ans.}$$

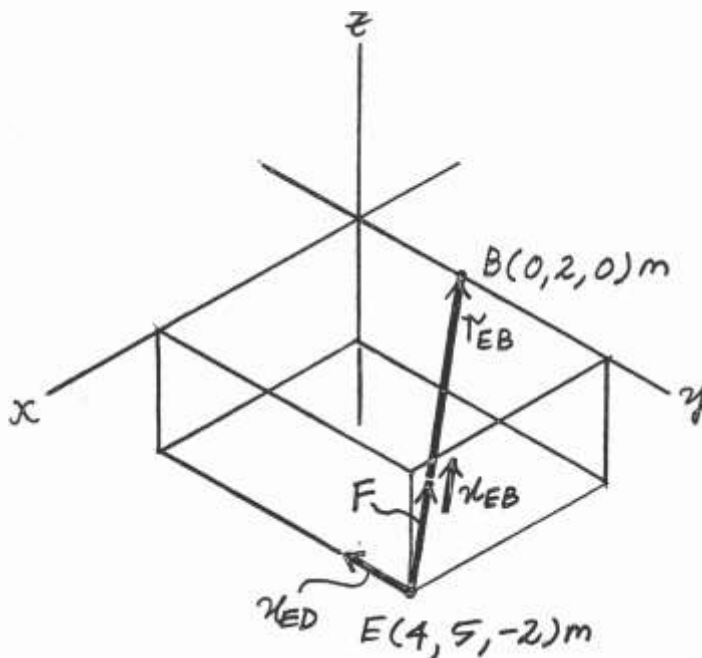

Ans:

$$(F_{ED}) = 334 \text{ N}$$

$$(F_{ED})_{\#} = 498 \text{ N}$$

2-114.

Determine the angle u between the two cables.

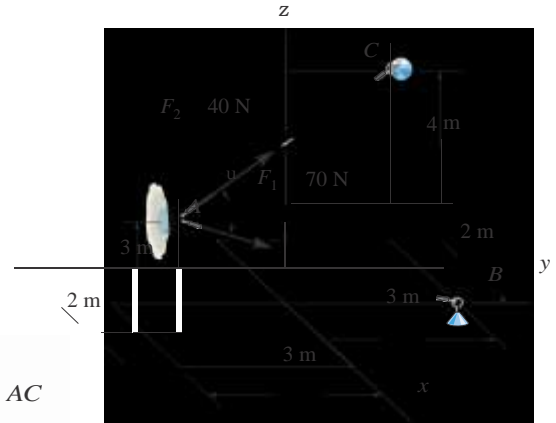

Solution

Unit Vectors. Here, the coordinates of points A, B and C are $A(2, -3, 3)$ m, $B(0, 3, 0)$ and $C(-2, 3, 4)$ m respectively. Thus, the unit vectors along AB and AC are

$$\mathbf{u}_{AB} = \frac{(0 - 2)\mathbf{i} + [3 - (-3)]\mathbf{j} + (0 - 3)\mathbf{k}}{\sqrt{(0 - 2)^2 + [3 - (-3)]^2 + (0 - 3)^2}} = -\frac{2}{7}\mathbf{i} + \frac{6}{7}\mathbf{j} - \frac{3}{7}\mathbf{k}$$

$$\mathbf{u}_{AC} = \frac{(-2 - 2)\mathbf{i} + [3 - (-3)]\mathbf{j} + (4 - 3)\mathbf{k}}{\sqrt{(-2 - 2)^2 + [3 - (-3)]^2 + (4 - 3)^2}} = -\frac{4}{\sqrt{53}}\mathbf{i} + \frac{6}{\sqrt{53}}\mathbf{j} + \frac{1}{\sqrt{53}}\mathbf{k}$$

The Angle u Between AB and AC .

$$\mathbf{u}_{AB} \cdot \mathbf{u}_{AC} = \left(-\frac{2}{7}\mathbf{i} + \frac{6}{7}\mathbf{j} - \frac{3}{7}\mathbf{k}\right) \cdot \left(-\frac{4}{\sqrt{53}}\mathbf{i} + \frac{6}{\sqrt{53}}\mathbf{j} + \frac{1}{\sqrt{53}}\mathbf{k}\right)$$

$$= \left(-\frac{2}{7}\right)\left(-\frac{4}{\sqrt{53}}\right) + \left(\frac{6}{7}\right)\left(\frac{6}{\sqrt{53}}\right) + \left(-\frac{3}{7}\right)\left(\frac{1}{\sqrt{53}}\right)$$

$$= \frac{41}{7\sqrt{53}}$$

Then

$$u = \cos^{-1}(\mathbf{u}_{AB} \cdot \mathbf{u}_{AC}) = \cos^{-1}\left(\frac{41}{7\sqrt{53}}\right) = 36.43^\circ = 36.4^\circ$$

Ans.

Ans:
 $u = 36.4$

2-115.

Determine the magnitude of the projection of the force \mathbf{F}_1 along cable AC .

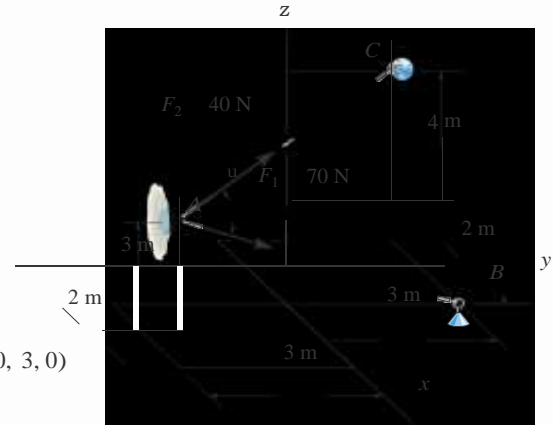

Solution

Unit Vectors. Here, the coordinates of points A, B and C are $A(2, -3, 3)\text{m}$, $B(0, 3, 0)$ and $C(-2, 3, 4)\text{m}$ respectively. Thus, the unit vectors along AB and AC are

$$\mathbf{u}_{AB} = \frac{(0 - 2)\mathbf{i} + [3 - (-3)]\mathbf{j} + (0 - 3)\mathbf{k}}{\sqrt{(0 - 2)^2 + [3 - (-3)]^2 + (0 - 3)^2}} = -\frac{2}{7}\mathbf{i} + \frac{6}{7}\mathbf{j} - \frac{3}{7}\mathbf{k}$$

$$\mathbf{u}_{AC} = \frac{(-2 - 2)\mathbf{i} + [3 - (-3)]\mathbf{j} + (4 - 3)\mathbf{k}}{\sqrt{(-2 - 2)^2 + [3 - (-3)]^2 + (4 - 3)^2}} = -\frac{4}{2\sqrt{53}}\mathbf{i} + \frac{6}{2\sqrt{53}}\mathbf{j} + \frac{1}{2\sqrt{53}}\mathbf{k}$$

Force Vector, For \mathbf{F}_1 ,

$$\mathbf{F}_1 = F_1 \mathbf{u}_{AB} = 70 \text{ a} - \frac{2}{7} \mathbf{i} + \frac{6}{7} \mathbf{j} - \frac{3}{7} \mathbf{k} \text{ b} = \{-20\mathbf{i} + 60\mathbf{j} - 30\mathbf{k}\} \text{ N}$$

Projected Component of \mathbf{F}_1 , Along AC , it is

$$\begin{aligned} (F_1)_{AC} &= \mathbf{F}_1 \cdot \mathbf{u}_{AC} = (-20\mathbf{i} + 60\mathbf{j} - 30\mathbf{k}) \cdot \left(-\frac{4}{2\sqrt{53}}\mathbf{i} + \frac{6}{2\sqrt{53}}\mathbf{j} + \frac{1}{2\sqrt{53}}\mathbf{k} \right) \\ &= (-20) \text{ a} - \frac{4}{2\sqrt{53}} \text{ b} + 60 \text{ a} \frac{6}{2\sqrt{53}} \text{ b} + (-30) \text{ a} \frac{1}{2\sqrt{53}} \text{ b} \end{aligned}$$

$$= 56.32 \text{ N} = 56.3 \text{ N}$$

Ans.

The positive sign indicates that this component points in the same direction as \mathbf{u}_{AC} .

Ans:
 $(F_1)_{AC} = 56.3 \text{ N}$

*2-116. A force of $F = 80 \text{ N}$ is applied to the handle of the wrench. Determine the angle u between the tail of the force and the handle AB .

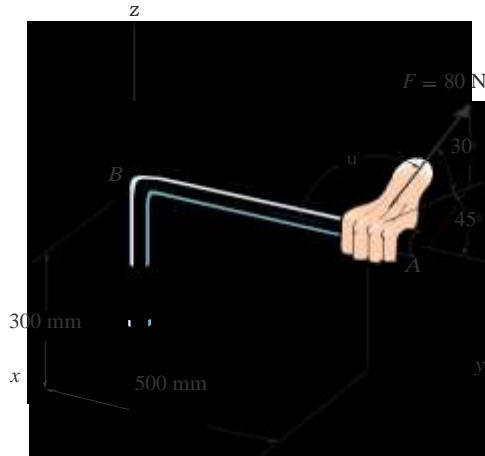

Solution

Given:

$$a = 300 \text{ mm}$$

$$b = 500 \text{ mm}$$

$$F = 80 \text{ N}$$

$$1 = 30^\circ$$

$$2 = 45^\circ$$

$$\cos 1 \sin 2 = 0$$

$$\mathbf{F}_v = F \cos 1 \cos 2 \quad \mathbf{u}_{ab} = 1$$

$$\sin 1 = 0$$

$$\text{acos} \frac{\mathbf{F}_v \cdot \mathbf{u}_{ab}}{F} = 127.8^\circ \quad \text{Ans.}$$

Ans:

2-117.

Determine the angle μ between the cables AB and AC .

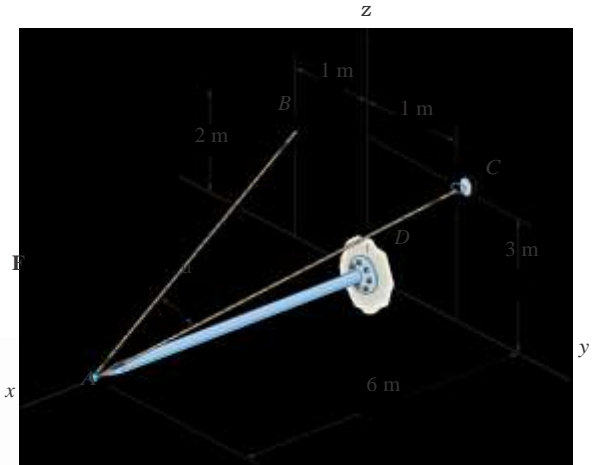

Solution

Unit Vectors. Here, the coordinates of points A, B and C are $A(6, 0, 0)$ m, $B(0, -1, 2)$ m and $C(0, 1, 3)$ respectively. Thus, the unit vectors along AB and AC are

$$\mathbf{u}_{AB} = \frac{(0 - 6)\mathbf{i} + (-1 - 0)\mathbf{j} + (2 - 0)\mathbf{k}}{\sqrt{(0 - 6)^2 + (-1 - 0)^2 + (2 - 0)^2}} = -\frac{6}{\sqrt{41}}\mathbf{i} - \frac{1}{\sqrt{41}}\mathbf{j} + \frac{2}{\sqrt{41}}\mathbf{k}$$

$$\mathbf{u}_{AC} = \frac{(0 - 6)\mathbf{i} + (1 - 0)\mathbf{j} + (3 - 0)\mathbf{k}}{\sqrt{(0 - 6)^2 + (1 - 0)^2 + (3 - 0)^2}} = -\frac{6}{\sqrt{46}}\mathbf{i} + \frac{1}{\sqrt{46}}\mathbf{j} + \frac{3}{\sqrt{46}}\mathbf{k}$$

The Angle μ Between AB and AC .

$$\mathbf{u}_{AB} \cdot \mathbf{u}_{AC} = \left(-\frac{6}{\sqrt{41}}\mathbf{i} - \frac{1}{\sqrt{41}}\mathbf{j} + \frac{2}{\sqrt{41}}\mathbf{k}\right) \cdot \left(-\frac{6}{\sqrt{46}}\mathbf{i} + \frac{1}{\sqrt{46}}\mathbf{j} + \frac{3}{\sqrt{46}}\mathbf{k}\right)$$

$$= \left(-\frac{6}{\sqrt{41}}\right)\left(-\frac{6}{\sqrt{46}}\right) + \left(-\frac{1}{\sqrt{41}}\right)\left(\frac{1}{\sqrt{46}}\right) + \left(\frac{2}{\sqrt{41}}\right)\left(\frac{3}{\sqrt{46}}\right)$$

$$= \frac{41}{\sqrt{1886}}$$

Then

$$\mu = \cos^{-1}(\mathbf{u}_{AB} \cdot \mathbf{u}_{AC}) = \cos^{-1}\left(\frac{41}{\sqrt{1886}}\right) = 19.24998^\circ = 19.2^\circ \quad \text{Ans.}$$

Ans:
 $u = 19.2$

2-118.

Determine the magnitude of the projected component of the force $\mathbf{F} = \{400\mathbf{i} - 200\mathbf{j} + 500\mathbf{k}\}$ N acting along the cable BA .

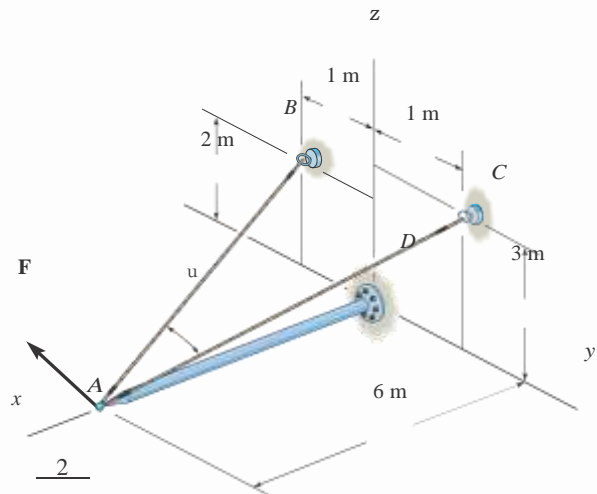

Solution

Unit Vector. Here, the coordinates of points A and B are $A(6, 0, 0)$ m and $B(0, -1, 2)$ m respectively. Thus the unit vector along BA is

$$\mathbf{r}_{BA} = \frac{(6 - 0)\mathbf{i} + [0 - (-1)]\mathbf{j} + (0 - 2)\mathbf{k}}{\sqrt{6^2 + 1^2 + 2^2}}$$

$$\mathbf{u}_{BA} = \frac{\mathbf{r}_{BA}}{r_{BA}} = \frac{6\mathbf{i} + \mathbf{j} - 2\mathbf{k}}{\sqrt{2(6^2 + 1^2 + 2^2)}} = \frac{6}{241}\mathbf{i} + \frac{1}{241}\mathbf{j} - \frac{2}{241}\mathbf{k}$$

Projected component of \mathbf{F} . Along BA , it is

$$\begin{aligned} F_{BA} &= \mathbf{F} \cdot \mathbf{u}_{BA} = (400\mathbf{i} - 200\mathbf{j} + 500\mathbf{k}) \cdot \left(\frac{6}{241}\mathbf{i} + \frac{1}{241}\mathbf{j} - \frac{2}{241}\mathbf{k} \right) \\ &= 400 \left(\frac{6}{241} \right) + (-200) \left(\frac{1}{241} \right) + 500 \left(-\frac{2}{241} \right) \\ &= 187.41 \text{ N} = 187 \text{ N} \end{aligned}$$

Ans.

The positive sign indicates that this component points in the same direction as \mathbf{u}_{BA} .

Ans:
 $F_{BA} = 187 \text{ N}$

2-119.

Determine the magnitude of the projected component of the force $\mathbf{F} = \{400\mathbf{i} - 200\mathbf{j} + 500\mathbf{k}\}$ N acting along the cable CA .

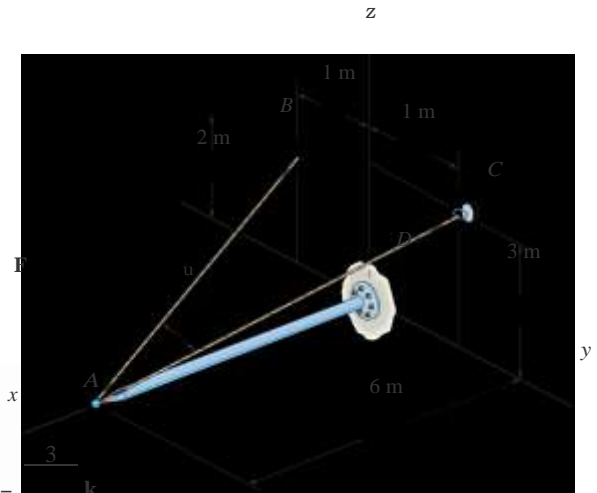

Solution

Unit Vector. Here, the coordinates of points A and C are $A(6, 0, 0)$ m and $C(0, 1, 3)$ m respectively. Thus, the unit vector along CA is

$$\mathbf{u}_{CA} = \frac{\mathbf{r}_{CA}}{r_{CA}} = \frac{(6 - 0)\mathbf{i} + (0 - 1)\mathbf{j} + (0 - 3)\mathbf{k}}{\sqrt{2(6 - 0)^2 + (0 - 1)^2 + (0 - 3)^2}} = \frac{6}{246}\mathbf{i} - \frac{1}{246}\mathbf{j} - \frac{3}{246}\mathbf{k}$$

Projected component of \mathbf{F} . Along CA , it is

$$\begin{aligned} \mathbf{F}_{CA} &= \mathbf{F} \cdot \mathbf{u}_{CA} = (400\mathbf{i} - 200\mathbf{j} + 500\mathbf{k}) \cdot \left(\frac{6}{246}\mathbf{i} - \frac{1}{246}\mathbf{j} - \frac{3}{246}\mathbf{k} \right) \\ &= 400 \left(\frac{6}{246} \right) + (-200) \left(-\frac{1}{246} \right) + 500 \left(-\frac{3}{246} \right) \\ &= 162.19 \text{ N} = 162 \text{ N} \end{aligned}$$

Ans.

The positive sign indicates that this component points in the same direction as \mathbf{u}_{CA} .

Ans:
 $F_{CA} = 162 \text{ N}$

*2-120. Determine the magnitude of the projected component of force \mathbf{F}_{AB} acting along the z axis.

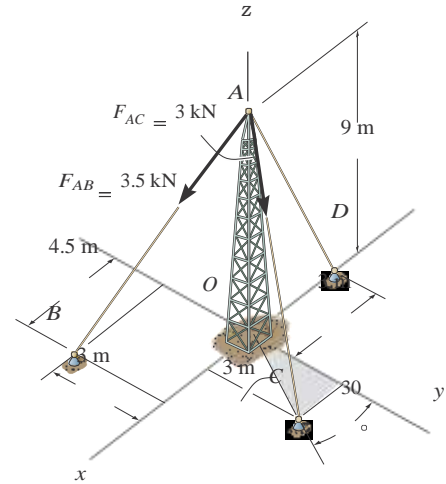

Solution

Unit Vector: The unit vector \mathbf{u}_{AB} must be determined first. From Fig. *a*,

$$\mathbf{u}_{AB} = \frac{\mathbf{r}_{AB}}{r_{AB}} = \frac{(4.5-0)\mathbf{i} + (-3-0)\mathbf{j} + (0-9)\mathbf{k}}{\sqrt{(4.5-0)^2 + (-3-0)^2 + (0-9)^2}} = \frac{3}{7}\mathbf{i} - \frac{2}{7}\mathbf{j} - \frac{6}{7}\mathbf{k}$$

Thus, the force vector \mathbf{F}_{AB} is given by

$$\mathbf{F}_{AB} = F_{AB}\mathbf{u}_{AB} = 3.5 \left(\frac{3}{7}\mathbf{i} - \frac{2}{7}\mathbf{j} - \frac{6}{7}\mathbf{k} \right) = \{1.5\mathbf{i} - 1\mathbf{j} - 3\mathbf{k}\} \text{ kN}$$

Vector Dot Product: The projected component of \mathbf{F}_{AB} along the z axis is

$$\begin{aligned} (F_{AB})_z &= \mathbf{F}_{AB} \cdot \mathbf{k} = (1.5\mathbf{i} - 1\mathbf{j} - 3\mathbf{k}) \cdot \mathbf{k} \\ &= -3 \text{ kN} \end{aligned}$$

The negative sign indicates that $(F_{AB})_z$ is directed towards the negative z axis. Thus

$$(F_{AB})_z = 3 \text{ kN}$$

Ans.

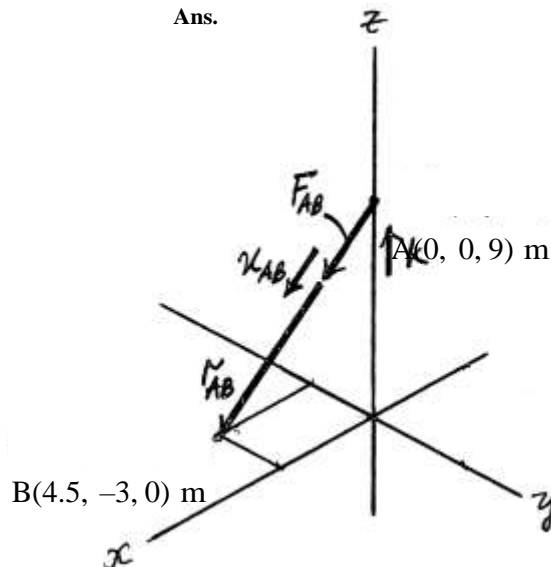

Ans:

$$(F_{AB})_z = 3 \text{ kN}$$

2-121. Determine the magnitude of the projected component of force \mathbf{F}_{AC} acting along the z axis.

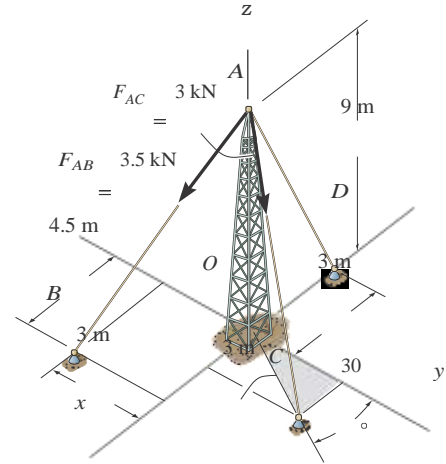

Solution

Unit Vector: The unit vector \mathbf{u}_{AC} must be determined first. From Fig. *a*,

$$\mathbf{u}_{AC} = \frac{\mathbf{r}_{AC}}{r_{AC}} = \frac{(3 \sin 30^\circ - 0)\mathbf{i} + (3 \cos 30^\circ - 0)\mathbf{j} + (0 - 9)\mathbf{k}}{\sqrt{(3 \sin 30^\circ - 0)^2 + (3 \cos 30^\circ - 0)^2 + (0 - 9)^2}} = 0.1581\mathbf{i} + 0.2739\mathbf{j} - 0.9487\mathbf{k}$$

Thus, the force vector \mathbf{F}_{AC} is given by

$$\mathbf{F}_{AC} = F_{AC}\mathbf{u}_{AC} = 3(0.1581\mathbf{i} + 0.2739\mathbf{j} - 0.9487\mathbf{k}) = \{0.4743\mathbf{i} + 0.8217\mathbf{j} - 2.8461\mathbf{k}\} \text{ kN}$$

Vector Dot Product: The projected component of \mathbf{F}_{AC} along the z axis is

$$\begin{aligned} (F_{AC})_z &= \mathbf{F}_{AC} \cdot \mathbf{k} = (0.4743\mathbf{i} + 0.8217\mathbf{j} - 2.8461\mathbf{k}) \cdot \mathbf{k} \\ &= -2.8461 \text{ kN} \end{aligned}$$

The negative sign indicates that $(F_{AC})_z$ is directed towards the negative z axis. Thus

$$(F_{AC})_z = 2.846 \text{ kN} \quad \text{Ans.}$$

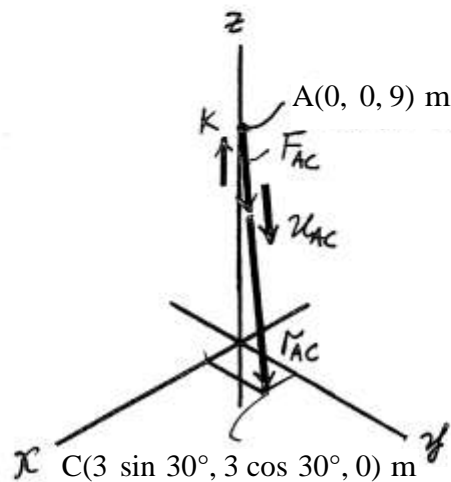

Ans:
 $1F_{AC}2_z = 2.846 \text{ kN}$

2-122.

Determine the components of \mathbf{F} that act along rod AC and perpendicular to it. Point B is located at the midpoint of the rod.

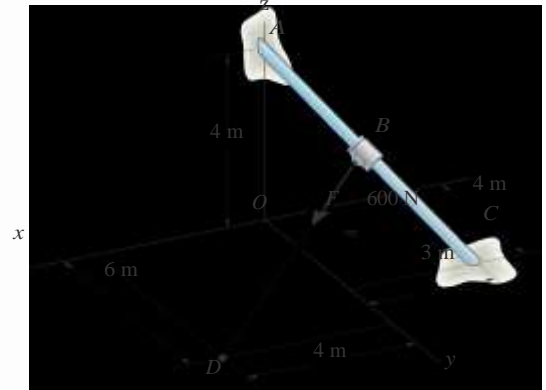

SOLUTION

$$\mathbf{r}_{AC} = (-3\mathbf{i} + 4\mathbf{j} - 4\mathbf{k}), \quad r_{AC} = \sqrt{(-3)^2 + 4^2 + (-4)^2} = \underline{241} \text{ m}$$

$$\mathbf{r}_{AB} = \frac{\mathbf{r}_{AC}}{2} = \frac{-3\mathbf{i} + 4\mathbf{j} + 4\mathbf{k}}{2} = -1.5\mathbf{i} + 2\mathbf{j} - 2\mathbf{k}$$

$$\mathbf{r}_{AD} = \mathbf{r}_{AB} + \mathbf{r}_{BD}$$

$$\begin{aligned} \mathbf{r}_{BD} &= \mathbf{r}_{AD} - \mathbf{r}_{AB} \\ &= (4\mathbf{i} + 6\mathbf{j} - 4\mathbf{k}) - (-1.5\mathbf{i} + 2\mathbf{j} - 2\mathbf{k}) \\ &= \underline{\{5.5\mathbf{i} + 4\mathbf{j} - 2\mathbf{k}\} \text{ m}} \end{aligned}$$

$$r_{BD} = \sqrt{(5.5)^2 + (4)^2 + (-2)^2} = 7.0887 \text{ m}$$

$$\mathbf{F} = 600 \frac{\mathbf{r}_{BD}}{r_{BD}} = 465.528\mathbf{i} + 338.5659\mathbf{j} - 169.2829\mathbf{k}$$

Component of \mathbf{F} along \mathbf{r}_{AC} is $F_{||}$

$$F_{||} = \frac{\mathbf{F} \cdot \mathbf{r}_{AC}}{r_{AC}} = \frac{(465.528\mathbf{i} + 338.5659\mathbf{j} - 169.2829\mathbf{k}) \cdot (-3\mathbf{i} + 4\mathbf{j} - 4\mathbf{k})}{241}$$

$$F_{||} = 99.1408 = 99.1 \text{ N}$$

Ans.

Component of F perpendicular to \mathbf{r}_{AC} is F^\perp

$$F^{\perp 2} + F_{||}^2 = F^2 = 600^2$$

$$F^{\perp 2} = 600^2 - 99.1408^2$$

$$F^\perp = 591.75 = 592 \text{ N}$$

Ans.

Ans:

$$F_{||} = 99.1 \text{ N}$$

$$F_{\#} = 592 \text{ N}$$

2-123.

Determine the components of \mathbf{F} that act along rod AC and perpendicular to it. Point B is located 3 m along the rod from end C .

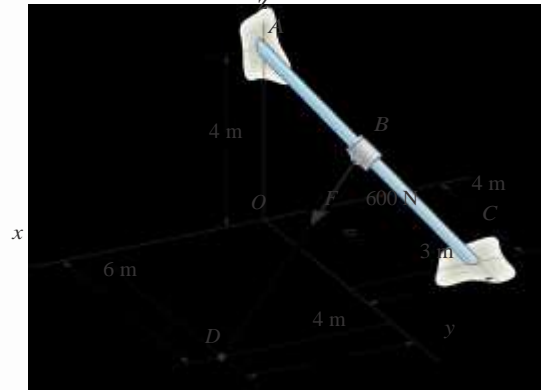

SOLUTION

$$\mathbf{r}_{CA} = 3\mathbf{i} - 4\mathbf{j} + 4\mathbf{k}$$

$$r_{CA} = 6.403124$$

$$\mathbf{r}_{CB} = \frac{3}{6.403124} (\mathbf{r}_{CA}) = 1.40556\mathbf{i} - 1.874085\mathbf{j} + 1.874085\mathbf{k}$$

$$\begin{aligned} \mathbf{r}_{OB} &= \mathbf{r}_{OC} + \mathbf{r}_{CB} \\ &= -3\mathbf{i} + 4\mathbf{j} + \mathbf{r}_{CB} \\ &= -1.59444\mathbf{i} + 2.1259\mathbf{j} + 1.874085\mathbf{k} \end{aligned}$$

$$\mathbf{r}_{OD} = \mathbf{r}_{OB} + \mathbf{r}_{BD}$$

$$\begin{aligned} \mathbf{r}_{BD} &= \mathbf{r}_{OD} - \mathbf{r}_{OB} = (4\mathbf{i} + 6\mathbf{j}) - \mathbf{r}_{OB} \\ &= 5.5944\mathbf{i} + 3.8741\mathbf{j} - 1.874085\mathbf{k} \end{aligned}$$

$$r_{BD} = \sqrt{(5.5944)^2 + (3.8741)^2 + (-1.874085)^2} = 7.0582$$

$$\mathbf{F} = 600 \left(\frac{\mathbf{r}_{BD}}{r_{BD}} \right) = 475.568\mathbf{i} + 329.326\mathbf{j} - 159.311\mathbf{k}$$

$$\mathbf{r}_{AC} = (-3\mathbf{i} + 4\mathbf{j} - 4\mathbf{k}), \quad r_{AC} = \sqrt{241}$$

Component of \mathbf{F} along \mathbf{r}_{AC} is $\mathbf{F}_{||}$

$$\mathbf{F}_{||} = \frac{\mathbf{F} \cdot \mathbf{r}_{AC}}{r_{AC}} = \frac{(475.568\mathbf{i} + 329.326\mathbf{j} - 159.311\mathbf{k}) \cdot (-3\mathbf{i} + 4\mathbf{j} - 4\mathbf{k})}{\sqrt{241}}$$

$$F_{||} = 82.4351 = 82.4 \text{ N}$$

Ans.

Component of \mathbf{F} perpendicular to \mathbf{r}_{AC} is \mathbf{F}^\perp

$$F^2 + F_{||}^2 = F^2 = 600^2$$

$$F^\perp = 600^2 - 82.4351^2$$

$$F^\perp = 594 \text{ N}$$

Ans.

Ans:
 $F_{||} = 82.4 \text{ N}$
 $F^\perp = 592 \text{ N}$

*2-124.

Determine the magnitudes of the projected components of the force $\mathbf{F} = [60\mathbf{i} + 12\mathbf{j} - 40\mathbf{k}]$ N along the cables AB and AC .

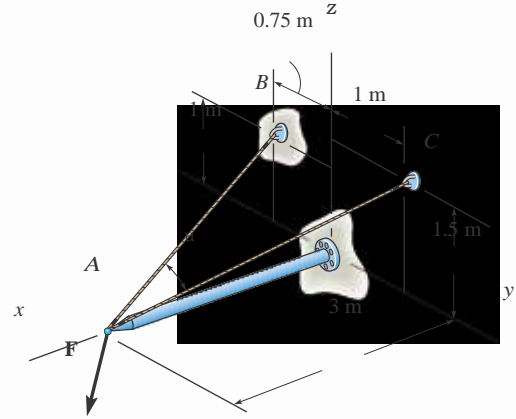

Solution

$$\mathbf{F} = \{60\mathbf{i} + 12\mathbf{j} - 40\mathbf{k}\} \text{ N}$$

$$\begin{aligned} \mathbf{u}_{AB} &= \frac{-3\mathbf{i} - 0.75\mathbf{j} + 1\mathbf{k}}{\sqrt{(-3)^2 + (-0.75)^2 + (1)^2}} \\ &= -0.9231\mathbf{i} - 0.2308\mathbf{j} + 0.3077\mathbf{k} \end{aligned}$$

$$\begin{aligned} \mathbf{u}_{AC} &= \frac{-3\mathbf{i} + 1\mathbf{j} + 1.5\mathbf{k}}{\sqrt{(-3)^2 + (1)^2 + (1.5)^2}} \\ &= -0.8571\mathbf{i} + 0.2857\mathbf{j} + 0.4286\mathbf{k} \end{aligned}$$

$$\begin{aligned} \text{Proj } F_{AB} &= \mathbf{F} \cdot \mathbf{u}_{AB} = (60)(-0.9231) + (12)(-0.2308) + (-40)(0.3077) \\ &= -70.46 \text{ N} \end{aligned}$$

$$|\text{Proj } F_{AB}| = 70.5 \text{ N}$$

$$\begin{aligned} \text{Proj } F_{AC} &= \mathbf{F} \cdot \mathbf{u}_{AC} = (60)(-0.8571) + (12)(0.2857) + (-40)(0.4286) \\ &= -65.14 \text{ N} \end{aligned}$$

$$|\text{Proj } F_{AC}| = 65.1 \text{ N}$$

Ans.

Ans.

Ans:

$$|\text{Proj } F_{AB}| = 70.5 \text{ N}$$

$$|\text{Proj } F_{AC}| = 65.1 \text{ N}$$

2-125.

Determine the angle u between cables AB and AC .

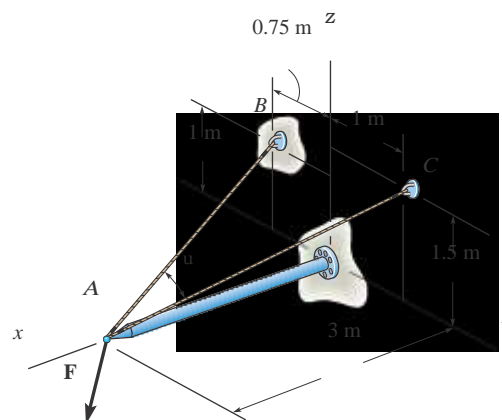

Solution

$$\mathbf{r}_{AB} = \{-3\mathbf{i} - 0.75\mathbf{j} + 1\mathbf{k}\} \text{ m}$$

$$r_{AB} = \sqrt{(-3)^2 + (-0.75)^2 + (1)^2} = 3.25 \text{ m}$$

$$\mathbf{r}_{AC} = \{-3\mathbf{i} + 1\mathbf{j} + 1.5\mathbf{k}\} \text{ m}$$

$$r_{AC} = \sqrt{(-3)^2 + (1)^2 + (1.5)^2} = 3.50 \text{ m}$$

$$\mathbf{r}_{AB} \cdot \mathbf{r}_{AC} = (-3)(-3) + (-0.75)(1) + (1)(1.5) = 9.75$$

$$u = \cos^{-1} \frac{\mathbf{r}_{AB} \cdot \mathbf{r}_{AC}}{r_{AB} r_{AC}} = \cos^{-1} \frac{9.75}{(3.25)(3.50)}$$

$$u = 31.0$$

Ans.

Ans:
 $u = 31.0$

2-126.

Determine the angles u and \mathbf{f} made between the axes OA of the flag pole and AB and AC , respectively, of each cable.

SOLUTION

$$\mathbf{r}_{AC} = \{-2\mathbf{i} - 4\mathbf{j} + 1\mathbf{k}\} \text{ m}; \quad r_{AC} = 4.58 \text{ m}$$

$$\mathbf{r}_{AB} = \{1.5\mathbf{i} - 4\mathbf{j} + 3\mathbf{k}\} \text{ m}; \quad r_{AB} = 5.22 \text{ m}$$

$$\mathbf{r}_{AO} = \{-4\mathbf{j} - 3\mathbf{k}\} \text{ m}; \quad r_{AO} = 5.00$$

m

$$\mathbf{r}_{AB} \cdot \mathbf{r}_{AO} = (1.5)(0) + (-4)(-4) + (3)(-3) = 7$$

$$u = \cos^{-1} \left(\frac{\mathbf{r}_{AB} \cdot \mathbf{r}_{AO}}{r_{AB} r_{AO}} \right)$$

$$= \cos^{-1} \left(\frac{7}{5.22(5.00)} \right) = 74.4^\circ$$

$$\mathbf{r}_{AC} \cdot \mathbf{r}_{AO} = (-2)(0) + (-4)(-4) + (1)(-3) = 13$$

$$\mathbf{f} = \cos^{-1} \left(\frac{\mathbf{r}_{AC} \cdot \mathbf{r}_{AO}}{r_{AC} r_{AO}} \right)$$

$$= \cos^{-1} \left(\frac{13}{4.58(5.00)} \right) = 55.4^\circ$$

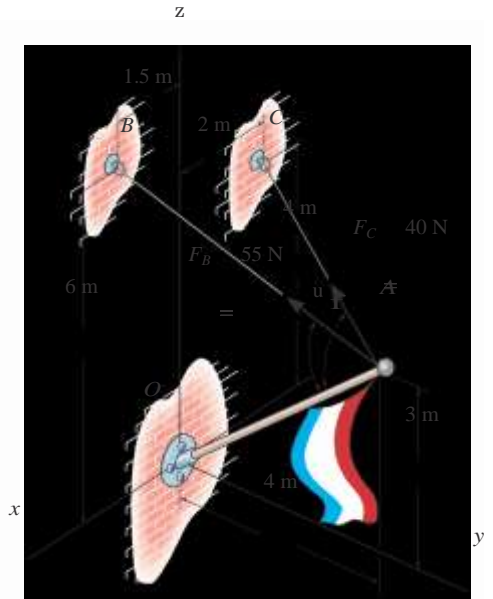

Ans.

Ans.

Ans:
u = 74.4

2-127.

Determine the angle u between BA and BC .

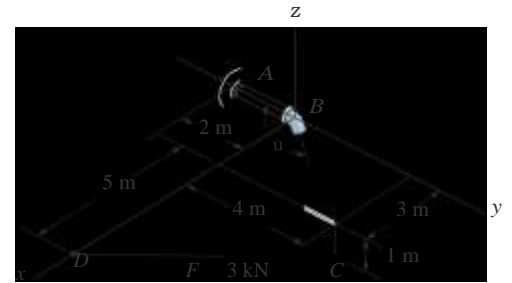

Solution

Unit Vectors. Here, the coordinates of points A , B and C are $A(0, -2, 0)$ m, $B(0, 0, 0)$ m and $C(3, 4, -1)$ m respectively. Thus, the unit vectors along BA and BC are

$$\mathbf{u}_{BA} = -\mathbf{j} \quad \mathbf{u}_{BC} = \frac{(3 - 0)\mathbf{i} + (4 - 0)\mathbf{j} + (-1 - 0)\mathbf{k}}{\sqrt{(3 - 0)^2 + (4 - 0)^2 + (-1 - 0)^2}} = \frac{3}{\sqrt{26}}\mathbf{i} + \frac{4}{\sqrt{26}}\mathbf{j} - \frac{1}{\sqrt{26}}\mathbf{k}$$

The Angle U Between BA and BC .

$$\begin{aligned} \mathbf{u}_{BA} \cdot \mathbf{u}_{BC} &= (-\mathbf{j}) \cdot \left[\frac{3}{\sqrt{26}}\mathbf{i} + \frac{4}{\sqrt{26}}\mathbf{j} - \frac{1}{\sqrt{26}}\mathbf{k} \right] \\ &= (-1) \left(\frac{4}{\sqrt{26}} \right) = -\frac{4}{\sqrt{26}} \end{aligned}$$

Then

$$u = \cos^{-1}(\mathbf{u}_{BA} \cdot \mathbf{u}_{BC}) = \cos^{-1} \left(-\frac{4}{\sqrt{26}} \right) = 141.67^\circ = 142^\circ \quad \text{Ans.}$$

Ans:
u = 142

*2-128.

Determine the magnitude of the projected component of the 3 kN force acting along the axis BC of the pipe.

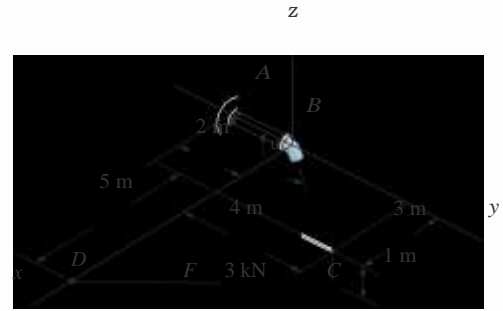

Solution

Unit Vectors. Here, the coordinates of points B , C and D are $B(0, 0, 0)$ m, $C(3, 4, -1)$ m and $D(8, 0, 0)$. Thus the unit vectors along BC and CD are

$$\mathbf{u}_{BC} = \frac{(3 - 0)\mathbf{i} + (4 - 0)\mathbf{j} + (-1 - 0)\mathbf{k}}{\sqrt{(3 - 0)^2 + (4 - 0)^2 + (-1 - 0)^2}} = \frac{3}{\sqrt{26}}\mathbf{i} + \frac{4}{\sqrt{26}}\mathbf{j} - \frac{1}{\sqrt{26}}\mathbf{k}$$

$$\mathbf{u}_{CD} = \frac{(8 - 3)\mathbf{i} + (0 - 4)\mathbf{j} + [0 - (-1)]\mathbf{k}}{\sqrt{(8 - 3)^2 + (0 - 4)^2 + [0 - (-1)]^2}} = \frac{5}{\sqrt{242}}\mathbf{i} - \frac{4}{\sqrt{242}}\mathbf{j} + \frac{1}{\sqrt{242}}\mathbf{k}$$

Force Vector. For \mathbf{F} ,

$$\mathbf{F} = F\mathbf{u}_{CD} = 3 \left[\frac{5}{\sqrt{242}}\mathbf{i} - \frac{4}{\sqrt{242}}\mathbf{j} + \frac{1}{\sqrt{242}}\mathbf{k} \right]$$

$$= \frac{15}{\sqrt{242}}\mathbf{i} - \frac{12}{\sqrt{242}}\mathbf{j} + \frac{3}{\sqrt{242}}\mathbf{k} \text{ kN}$$

Projected Component of \mathbf{F} Along BC , it is

$$(F_{BC}) = \mathbf{F} \cdot \mathbf{u}_{BC} = \left[\frac{15}{\sqrt{242}}\mathbf{i} - \frac{12}{\sqrt{242}}\mathbf{j} + \frac{3}{\sqrt{242}}\mathbf{k} \right] \cdot \left[\frac{3}{\sqrt{26}}\mathbf{i} + \frac{4}{\sqrt{26}}\mathbf{j} - \frac{1}{\sqrt{26}}\mathbf{k} \right]$$

$$= \frac{15}{\sqrt{242}} \frac{3}{\sqrt{26}} - \frac{12}{\sqrt{242}} \frac{4}{\sqrt{26}} + \frac{3}{\sqrt{242}} \frac{-1}{\sqrt{26}}$$

$$= \frac{45}{\sqrt{6252}} - \frac{48}{\sqrt{6252}} - \frac{3}{\sqrt{6252}} = \frac{-6}{\sqrt{1092}} = -0.1816 \text{ kN} = 0.182 \text{ kN} \quad \text{Ans.}$$

The negative signs indicate that this component points in the direction opposite to that of \mathbf{u}_{BC} .

Ans:
0.182 kN

2-129.

Determine the angles α and β between the axis OA of the pole and each cable, AB and AC .

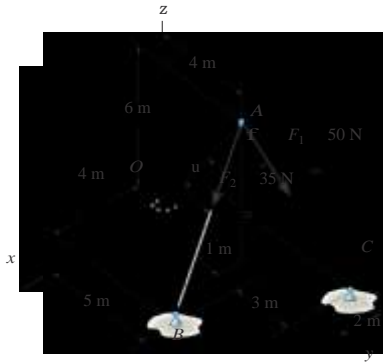

Solution

Given:

$F_1 = 50\text{ N}$

$F_2 = 35\text{ N}$

$a = 1\text{ m}$

$b = 3\text{ m}$

$c = 2\text{ m}$

$d = 5\text{ m}$

$e = 4\text{ m}$

$f = 6\text{ m}$

$g = 4\text{ m}$

$$\begin{matrix} & 0 & e & c \\ \mathbf{r_{AO}} & g & \mathbf{r_{AB}} & a & \mathbf{r_{AC}} & a & b \\ & f & & f & & f \end{matrix}$$

$$\alpha = \arccos \frac{\mathbf{r_{AO}} \cdot \mathbf{r_{AB}}}{|\mathbf{r_{AO}}| |\mathbf{r_{AB}}|} = 52.4^\circ \quad \text{Ans.}$$

$$\beta = \arccos \frac{\mathbf{r_{AO}} \cdot \mathbf{r_{AC}}}{|\mathbf{r_{AO}}| |\mathbf{r_{AC}}|} = 68.2^\circ \quad \text{Ans.}$$

$$u = 52.4$$
$$f = 68.2$$

2-130.

The two cables exert the forces shown on the pole. Determine the magnitude of the projected component of each force acting along the axis OA of the pole.

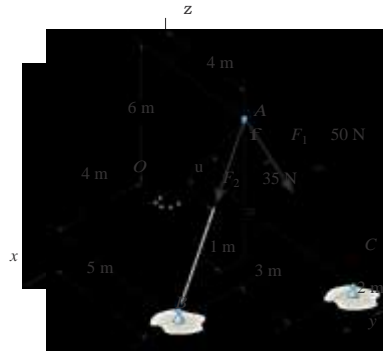

Solution

Given:

$F_1 = 50 \text{ N}$

$F_2 = 35 \text{ N}$

$a = 1 \text{ m}$

$b = 3 \text{ m}$

$c = 2 \text{ m}$

$d = 5 \text{ m}$

$e = 4 \text{ m}$

$f = 6 \text{ m}$

$g = 4 \text{ m}$

$$\mathbf{r}_{AB} = \frac{a}{f} \mathbf{i} + \frac{b}{f} \mathbf{j} + \frac{c}{f} \mathbf{k} \quad \mathbf{r}_{AC} = \frac{a}{f} \mathbf{i} + \frac{b}{f} \mathbf{j} + \frac{c}{f} \mathbf{k} \quad \mathbf{r}_{AO} = \frac{g}{f} \mathbf{i} + \frac{e}{f} \mathbf{j} + \frac{0}{f} \mathbf{k} \quad \mathbf{u}_{AO} = \frac{\mathbf{r}_{AO}}{|\mathbf{r}_{AO}|}$$

$$\mathbf{F}_{1v} = F_1 \frac{|\mathbf{r}_{AC}|}{|\mathbf{r}_{AC}|} \quad F_{1AO} = \mathbf{F}_{1v} \cdot \mathbf{u}_{AO} \quad F_{1AO} = 18.5 \text{ N} \quad \text{Ans.}$$

$$\mathbf{F}_{2v} = F_2 \frac{|\mathbf{r}_{AB}|}{|\mathbf{r}_{AB}|} \quad F_{2AO} = \mathbf{F}_{2v} \cdot \mathbf{u}_{AO} \quad F_{2AO} = 21.3 \text{ N} \quad \text{Ans.}$$

Ans:
 $F_{1AO} = 18.5 \text{ N}$

$$F_{2AO} = 21.3 \text{ N}$$

2-131.

Determine the magnitude of the projection of force $F = 600 \text{ N}$ along the u axis.

SOLUTION

Unit Vectors: The unit vectors \mathbf{u}_{OA} and \mathbf{u}_u must be determined first. From Fig. *a*,

$$\mathbf{u}_{OA} = \frac{\mathbf{r}_{OA}}{r_{OA}} = \frac{(-2 - 0)\mathbf{i} + (4 - 0)\mathbf{j} + (4 - 0)\mathbf{k}}{\sqrt{(-2 - 0)^2 + (4 - 0)^2 + (4 - 0)^2}} = -\frac{1}{3}\mathbf{i} + \frac{2}{3}\mathbf{j} + \frac{2}{3}\mathbf{k}$$

$$\mathbf{u}_u = \sin 30^\circ \mathbf{i} + \cos 30^\circ \mathbf{j}$$

Thus, the force vectors \mathbf{F} is given by

$$\mathbf{F} = F \mathbf{u}_{OA} = 600 \text{ a} - \frac{1}{3}\mathbf{i} - \frac{2}{3}\mathbf{j} + \frac{2}{3}\mathbf{k} \text{ b} = 5 - 200\mathbf{i} + 400\mathbf{j} + 400\mathbf{k} \text{ 6 N}$$

Vector Dot Product: The magnitude of the projected component of \mathbf{F} along the u axis is

$$\begin{aligned} F_u &= F \mathbf{i} \cdot \mathbf{u}_u = (-200\mathbf{i} + 400\mathbf{j} + 400\mathbf{k}) \cdot (\sin 30^\circ \mathbf{i} + \cos 30^\circ \mathbf{j}) \\ &= (-200)(\sin 30^\circ) + 400(\cos 30^\circ) + 400(0) \\ &= 246 \text{ N} \end{aligned}$$

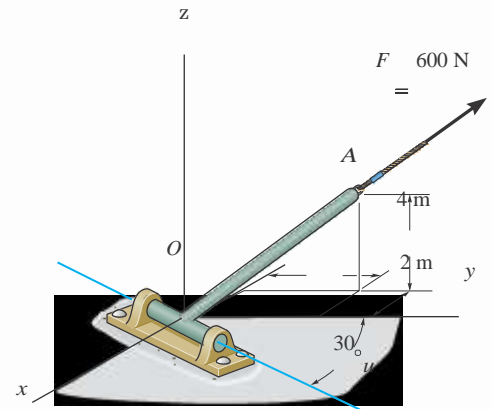

Ans.

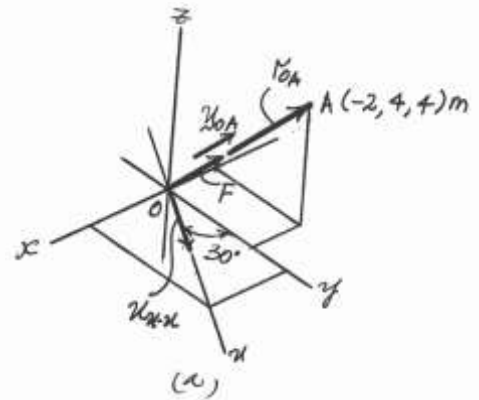

Ans:
 $F_u = 246 \text{ N}$

*2-132.

Determine the projected component of the force \mathbf{F} acting along the axis AB of the pipe.

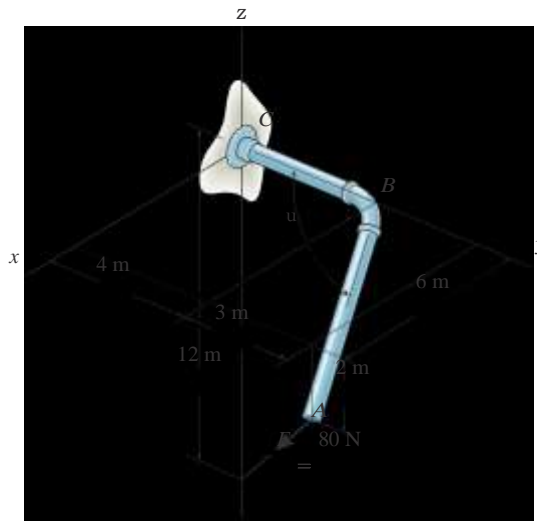

Solution

Given:

- $F = 80 \text{ N}$
- $a = 4 \text{ m}$
- $b = 3 \text{ m}$
- $c = 12 \text{ m}$
- $d = 2 \text{ m}$
- $e = 6 \text{ m}$

Find the force and the unit vector

	e	6			35.3
\mathbf{r}_A	a	b	\mathbf{r}_A	7 m	
	d	c		10	
	e	6			
\mathbf{r}_{AB}	b	3 m	\mathbf{u}_{AB}		0.4
	d	2			
					0.3
					58.8
					41.2 N

Now find the projection using the Dot product.

$F_{AB} = \mathbf{F}_v \cdot \mathbf{u}_{AB} = 31.1 \text{ N}$ **Ans.**

Ans:
 F_{AB} 31.1 N

2-133.

The cables each exert a force of 400 N on the post. Determine the magnitude of the projected component of \mathbf{F}_1 along the line of action of \mathbf{F}_2 .

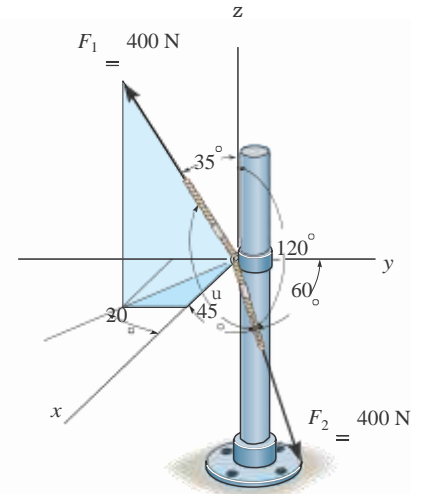

SOLUTION

Force Vector:

$$\begin{aligned} \mathbf{u}_{F_1} &= \sin 35^\circ \cos 20^\circ \mathbf{i} - \sin 35^\circ \sin 20^\circ \mathbf{j} + \cos 35^\circ \mathbf{k} \\ &= 0.5390\mathbf{i} - 0.1962\mathbf{j} + 0.8192\mathbf{k} \end{aligned}$$

$$\begin{aligned} \mathbf{F}_1 &= F_1 \mathbf{u}_{F_1} = 400(0.5390\mathbf{i} - 0.1962\mathbf{j} + 0.8192\mathbf{k}) \text{ N} \\ &= \{215.59\mathbf{i} - 78.47\mathbf{j} + 327.66\mathbf{k}\} \text{ N} \end{aligned}$$

Unit Vector: The unit vector along the line of action of \mathbf{F}_2 is

$$\begin{aligned} \mathbf{u}_{F_2} &= \cos 45^\circ \mathbf{i} + \cos 60^\circ \mathbf{j} + \cos 120^\circ \mathbf{k} \\ &= 0.7071\mathbf{i} + 0.5\mathbf{j} - 0.5\mathbf{k} \end{aligned}$$

Projected Component of \mathbf{F}_1 Along Line of Action of \mathbf{F}_2 :

$$\begin{aligned} (F_1)_{F_2} &= \mathbf{F}_1 \cdot \mathbf{u}_{F_2} = (215.59\mathbf{i} - 78.47\mathbf{j} + 327.66\mathbf{k}) \cdot (0.7071\mathbf{i} + 0.5\mathbf{j} - 0.5\mathbf{k}) \\ &= (215.59)(0.7071) + (-78.47)(0.5) + (327.66)(-0.5) \\ &= -50.6 \text{ N} \end{aligned}$$

Negative sign indicates that the force component $(\mathbf{F}_1)_{F_2}$ acts in the opposite sense of direction to that of \mathbf{u}_{F_2} .
thus the magnitude is $(F_1)_{F_2} = 50.6 \text{ N}$

Ans.

Ans:

$$1_{F_1}2_{F_2} = 50.6 \text{ N}$$

2-134.

Determine the angle u between the two cables attached to the post.

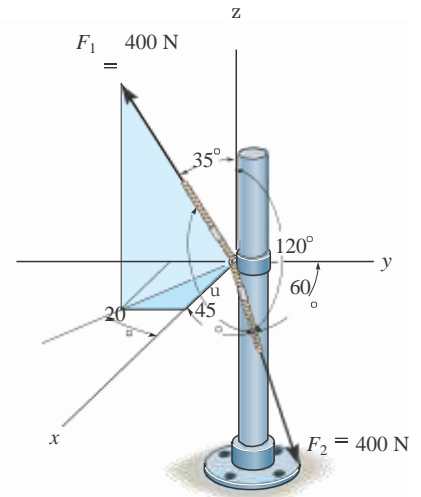

SOLUTION

Unit Vector:

$$\begin{aligned} \mathbf{u}_{F_1} &= \sin 35^\circ \cos 20^\circ \mathbf{i} - \sin 35^\circ \sin 20^\circ \mathbf{j} + \cos 35^\circ \mathbf{k} \\ &= 0.5390\mathbf{i} - 0.1962\mathbf{j} + 0.8192\mathbf{k} \end{aligned}$$

$$\begin{aligned} \mathbf{u}_{F_2} &= \cos 45^\circ \mathbf{i} + \cos 60^\circ \mathbf{j} + \cos 120^\circ \mathbf{k} \\ &= 0.7071\mathbf{i} + 0.5\mathbf{j} - 0.5\mathbf{k} \end{aligned}$$

The Angle Between Two Vectors u : The dot product of two unit vectors must be determined first.

$$\begin{aligned} \mathbf{u}_{F_1} \cdot \mathbf{u}_{F_2} &= (0.5390\mathbf{i} - 0.1962\mathbf{j} + 0.8192\mathbf{k}) \cdot (0.7071\mathbf{i} + 0.5\mathbf{j} - 0.5\mathbf{k}) \\ &= 0.5390(0.7071) + (-0.1962)(0.5) + 0.8192(-0.5) \\ &= -0.1265 \end{aligned}$$

Then,

$$u = \cos^{-1} \mathbf{u}_{F_1} \cdot \mathbf{u}_{F_2} = \cos^{-1}(-0.1265) = 97.3^\circ$$

Ans.

Ans:
 $u = 97.3$

2-135.

If the force $F = 100 \text{ N}$ lies in the plane $DBEC$, which is parallel to the $x-z$ plane, and makes an angle of 10° with the extended line DB as shown, determine the angle that F makes with the diagonal AB of the crate.

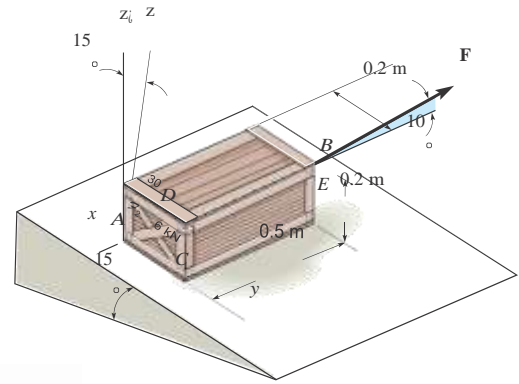

Solution

Use the x, y, z axes.

$$\mathbf{u}_{AB} = a \frac{-0.5\mathbf{i} + 0.2\mathbf{j} + 0.2\mathbf{k}}{0.57446} b$$

$$= -0.8704\mathbf{i} + 0.3482\mathbf{j} + 0.3482\mathbf{k}$$

$$\mathbf{F} = -100 \cos 10^\circ \mathbf{i} + 100 \sin 10^\circ \mathbf{k}$$

$$u = \cos^{-1} a \frac{\mathbf{F} \cdot \mathbf{u}_{AB}}{F u_{AB}} b$$

$$= \cos^{-1} a \frac{-100 (\cos 10^\circ)(-0.8704) + 0 + 100 \sin 10^\circ (0.3482)}{100(1)} b$$

$$= \cos^{-1}(0.9176) = 23.4$$

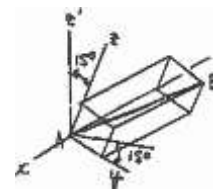

Ans.

Ans:
 $u = 23.4$

*2-136.

Determine the magnitudes of the projected components of the force $F = 300 \text{ N}$ acting along the x and y axes.

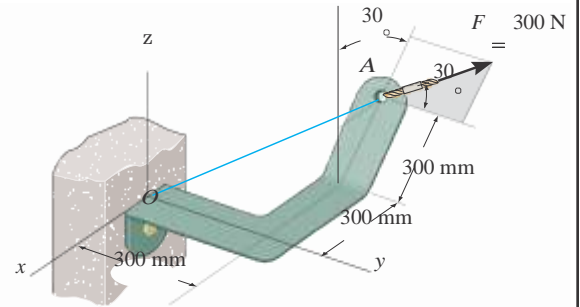

SOLUTION

Force Vector: The force vector \mathbf{F} must be determined first. From Fig. *a*,

$$\begin{aligned}\mathbf{F} &= -300 \sin 30^\circ \sin 30^\circ \mathbf{i} + 300 \cos 30^\circ \mathbf{j} + 300 \sin 30^\circ \cos 30^\circ \mathbf{k} \\ &= [-75\mathbf{i} + 259.81\mathbf{j} + 129.90\mathbf{k}] \text{ N}\end{aligned}$$

Vector Dot Product: The magnitudes of the projected component of \mathbf{F} along the x and y axes are

$$\begin{aligned}F_x &= \mathbf{F} \cdot \mathbf{i} = [-75\mathbf{i} + 259.81\mathbf{j} + 129.90\mathbf{k}] \cdot \mathbf{i} \\ &= -75(1) + 259.81(0) + 129.90(0) \\ &= -75 \text{ N}\end{aligned}$$

$$\begin{aligned}F_y &= \mathbf{F} \cdot \mathbf{j} = [-75\mathbf{i} + 259.81\mathbf{j} + 129.90\mathbf{k}] \cdot \mathbf{j} \\ &= -75(0) + 259.81(1) + 129.90(0) \\ &= 260 \text{ N}\end{aligned}$$

The negative sign indicates that F_x is directed towards the negative x axis. Thus

$$F_x = 75 \text{ N}, \quad F_y = 260 \text{ N} \quad \text{Ans.}$$

$$\begin{aligned}\text{Ans:} \\ F_x &= 75 \text{ N} \\ F_y &= 260 \text{ N}\end{aligned}$$

2-137.

Determine the magnitude of the projected component of the force $F = 300 \text{ N}$ acting along line OA .

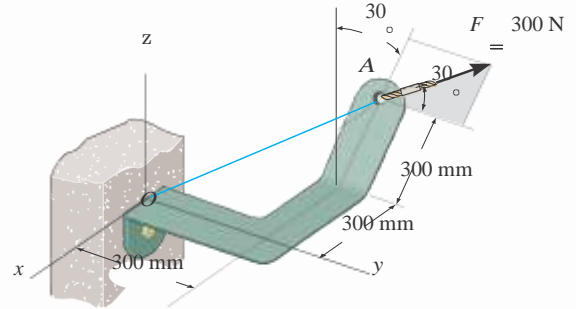

SOLUTION

Force and Unit Vector: The force vector \mathbf{F} and unit vector \mathbf{u}_{OA} must be determined first. From Fig. a

$$\begin{aligned} \mathbf{F} &= (-300 \sin 30^\circ \sin 30^\circ \mathbf{i} + 300 \cos 30^\circ \mathbf{j} + 300 \sin 30^\circ \cos 30^\circ \mathbf{k}) \\ &= \{-75\mathbf{i} + 259.81\mathbf{j} + 129.90\mathbf{k}\} \text{ N} \\ \mathbf{u}_{OA} &= \frac{\mathbf{r}_{OA}}{r_{OA}} = \frac{(-0.45 - 0)\mathbf{i} + (0.3 - 0)\mathbf{j} + (0.2598 - 0)\mathbf{k}}{\sqrt{(-0.45 - 0)^2 + (0.3 - 0)^2 + (0.2598 - 0)^2}} = -0.75\mathbf{i} + 0.5\mathbf{j} + 0.4330\mathbf{k} \end{aligned}$$

Vector Dot Product: The magnitude of the projected component of \mathbf{F} along line OA is

$$\begin{aligned} F_{OA} &= \mathbf{F} \cdot \mathbf{u}_{OA} = \{-75\mathbf{i} + 259.81\mathbf{j} + 129.90\mathbf{k}\} \cdot \{-0.75\mathbf{i} + 0.5\mathbf{j} + 0.4330\mathbf{k}\} \\ &= (-75)(-0.75) + 259.81(0.5) + 129.90(0.4330) \\ &= 242 \text{ N} \end{aligned} \quad \text{Ans.}$$

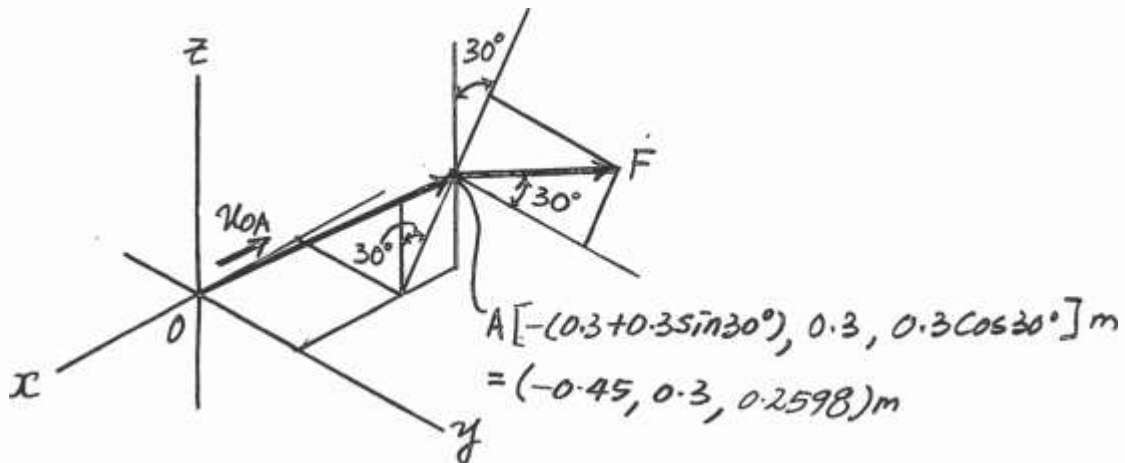

Ans:
 $F_{OA} = 242 \text{ N}$

2-138. Cable OA is used to support column OB . Determine the angle u it makes with beam OC .

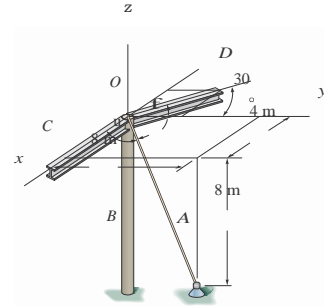

Solution

Unit Vector:

$$\begin{aligned} \mathbf{u}_{OC} &= \mathbf{i} \\ \mathbf{u}_{OA} &= \frac{(4 - 0)\mathbf{i} + (8 - 0)\mathbf{j} + (-8 - 0)\mathbf{k}}{\sqrt{(4 - 0)^2 + (8 - 0)^2 + (-8 - 0)^2}} \\ &= \frac{1}{3}\mathbf{i} + \frac{2}{3}\mathbf{j} - \frac{2}{3}\mathbf{k} \end{aligned}$$

The Angles Between Two Vectors U : —

$$\mathbf{u}_{OC} \cdot \mathbf{u}_{OA} = (\mathbf{i}) \cdot \left(\frac{1}{3}\mathbf{i} + \frac{2}{3}\mathbf{j} - \frac{2}{3}\mathbf{k} \right) = 1 \cdot \frac{1}{3} + 0 \cdot \frac{2}{3} + 0 \cdot \left(-\frac{2}{3}\right) = \frac{1}{3}$$

Then,

$$U = \cos^{-1}(\mathbf{u}_{OC} \cdot \mathbf{u}_{OA}) = \cos^{-1}\left(\frac{1}{3}\right) = 70.5 \quad \text{Ans.}$$

Ans:
u = 70.5

2-139. Cable OA is used to support column OB . Determine the angle \mathbf{f} it makes with beam OD .

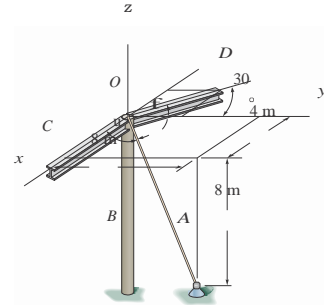

Solution

Unit Vector:

$$\mathbf{u}_{OD} = -\sin 30 \mathbf{i} + \cos 30 \mathbf{j} = -0.5\mathbf{i} + 0.8660\mathbf{j}$$

$$\begin{aligned} \mathbf{u}_{OA} &= \frac{(4 - 0)\mathbf{i} + (8 - 0)\mathbf{j} + (-8 - 0)\mathbf{k}}{\sqrt{(4 - 0)^2 + (8 - 0)^2 + (-8 - 0)^2}} \\ &= \frac{1}{3}\mathbf{i} + \frac{2}{3}\mathbf{j} - \frac{2}{3}\mathbf{k} \end{aligned}$$

The Angles Between Two Vectors F: –

$$\begin{aligned} \mathbf{u}_{OD} \cdot \mathbf{u}_{OA} &= (-0.5\mathbf{i} + 0.8660\mathbf{j}) \cdot \left(\frac{1}{3}\mathbf{i} + \frac{2}{3}\mathbf{j} - \frac{2}{3}\mathbf{k}\right) \\ &= (-0.5)\left(\frac{1}{3}\right) + (0.8660)\left(\frac{2}{3}\right) + 0\left(-\frac{2}{3}\right) \\ &= 0.4107 \end{aligned}$$

Then,

$$F = \cos^{-1}(\mathbf{u}_{OD} \cdot \mathbf{u}_{OA}) = \cos^{-1}0.4107 = 65.8$$

Ans.

Ans:
f = 65.8