

Test Bank for College Algebra Graphs and Models 6th Edition by Bittinger ISBN 013417903X 9780134179032

Full link download:

Test Bank:

<https://testbankpack.com/p/test-bank-for-college-algebra-graphs-and-models-6th-edition-by-bittinger-isbn-013417903x-9780134179032/>

Solution Manual:

<https://testbankpack.com/p/solution-manual-for-college-algebra-graphs-and-models-6th-edition-by-bittinger-isbn-013417903x-9780134179032/>

MULTIPLE CHOICE. Choose the one alternative that best completes the statement or answers the question.

Determine the intervals on which the function is increasing, decreasing, and constant.

1)

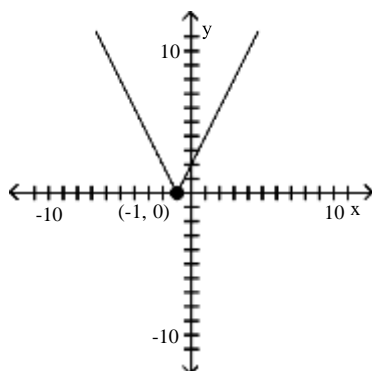

- A) Increasing on $(1, \infty)$; Decreasing on $(-\infty, 1)$
- B) Increasing on $(-\infty, -1)$; Decreasing on $(-1, \infty)$
- C) Increasing on $(-1, \infty)$; Decreasing on $(-\infty, -1)$
- D) Increasing on $(-\infty, 1)$; Decreasing on $(1, \infty)$

Answer: C

2)

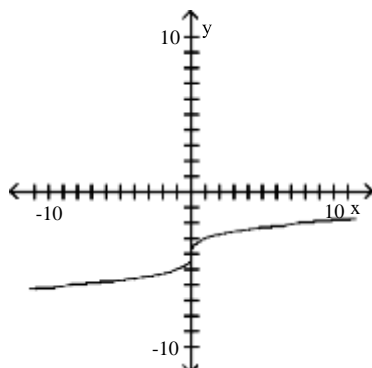

- A) Decreasing on $(-\infty, \infty)$

B) Increasing on $(-\infty, \infty)$

C) Increasing on $(0, \infty)$; Decreasing on $(-\infty, 0)$

D) Increasing on $(-\infty, 0)$; Decreasing on $(0, \infty)$

Answer: B

3)

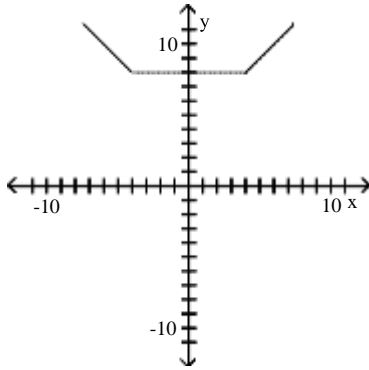

- A) Increasing on $(-\infty, 4)$; Decreasing on $(-4, \infty)$; Constant on $(4, \infty)$
- B) Increasing on $(4, \infty)$; Decreasing on $(-4, \infty)$; Constant on $(-4, 4)$
- C) Increasing on $(4, \infty)$; Decreasing on $(-\infty, -4)$; Constant on $(-4, 4)$
- D) Increasing on $(-\infty, 4)$; Decreasing on $(-\infty, -4)$; Constant on $(4, \infty)$

Answer: C

4)

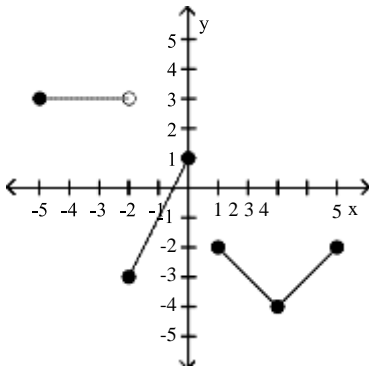

- A) Increasing on $(-2, 0)$ and $(3, 4)$; Decreasing on $(-5, -2)$ and $(1, 3)$
- B) Increasing on $(1, 3)$; Decreasing on $(-2, 0)$ and $(3, 5)$; Constant on $(2, 5)$
- C) Increasing on $(-2, 0)$ and $(3, 5)$; Decreasing on $(1, 3)$; Constant on $(-5, -2)$
- D) Increasing on $(-1, 0)$ and $(3, 5)$; Decreasing on $(0, 3)$; Constant on $(-5, -3)$

Answer: C

5)

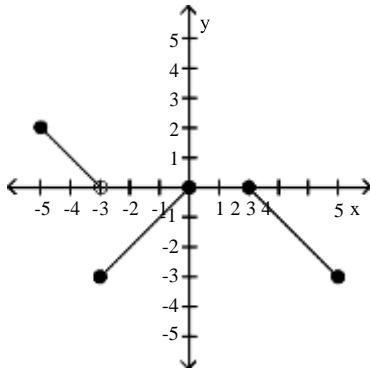

- A) Increasing on $(-3, -1)$; Decreasing on $(-5, -2)$ and $(2, 4)$; Constant on $(-1, 2)$
- B) Increasing on $(-3, 0)$; Decreasing on $(-5, -3)$ and $(2, 5)$; Constant on $(0, 2)$
- C) Increasing on $(-5, -3)$ and $(2, 5)$; Decreasing on $(-3, 0)$; Constant on $(0, 2)$
- D) Increasing on $(-3, 1)$; Decreasing on $(-5, -3)$ and $(0, 5)$; Constant on $(1, 2)$

Answer: B

Determine the domain and range of the function.

6)

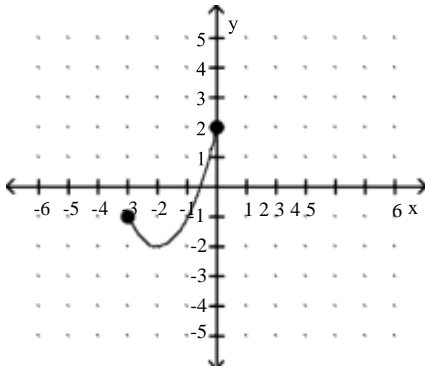

- A) domain: $[0, 3]$; range: $(-\infty, 2]$
- B) domain: $[-2, 2]$; range: $[-3, 0]$
- C) domain: $[-3, 0]$; range: $[-2, 2]$
- D) domain: $(-\infty, 2]$; range: $[0, 3]$

Answer: C

7)

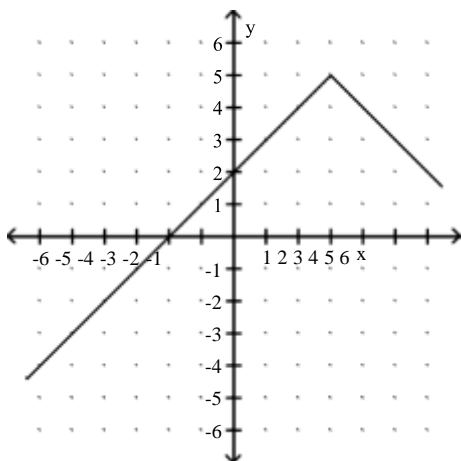

- A) domain: $(-\infty, \infty)$; range: $(-\infty, 5]$
- B) domain: $(-\infty, 3]$; range: $(-\infty, 5]$ C) domain: $(-\infty, \infty)$; range: $(-\infty, \infty)$
- D) domain: $(-\infty, 3) \cup (3, \infty)$; range: $(-\infty, 5) \cup (5, \infty)$

Answer: A

8)

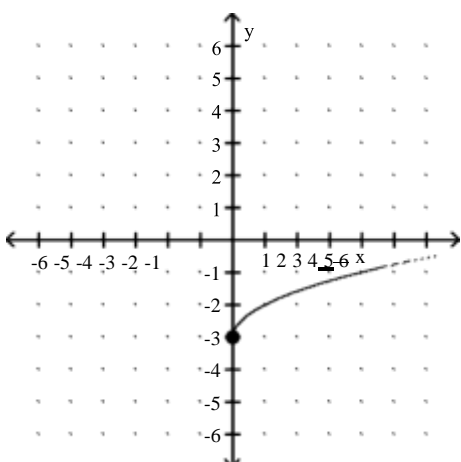

- A) domain: $[0, \infty)$; range: $(-\infty, \infty)$
- B) domain: $[0, \infty)$; range: $[0, \infty)$
- C) domain: $(-\infty, \infty)$; range: $[-3, \infty)$
- D) domain: $[0, \infty)$; range: $[-3, \infty)$

Answer: D

9)

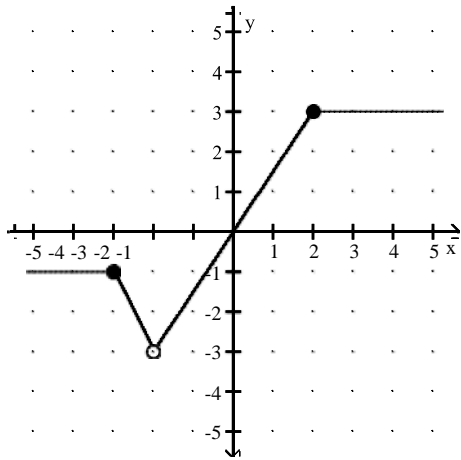

- A) domain: $(-3, 3]$; range: $(-\infty, \infty)$
- B) domain: $(-\infty, \infty)$; range: $[-3, 3]$
- C) domain: $(-\infty, \infty)$; range: $(-3, 3]$
- D) domain: $(-\infty, \infty)$; range: $[-3, 3)$

Answer: C

10)

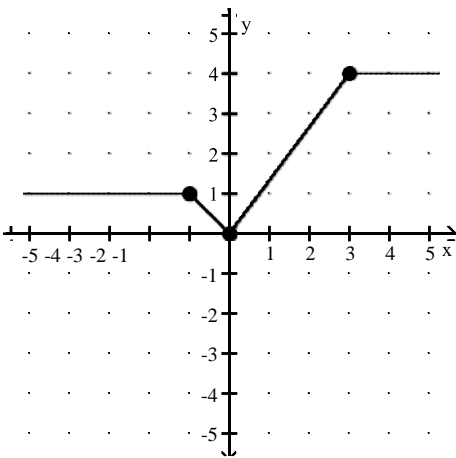

- A) domain: $(-\infty, \infty)$; range: $[0, 4]$
- B) domain: $(-\infty, \infty)$; range: $(0, 4)$
- C) domain: $(0, 4)$; range: $(-\infty, \infty)$
- D) domain: $[0, 4]$; range: $(-\infty, \infty)$

Answer: A

11)

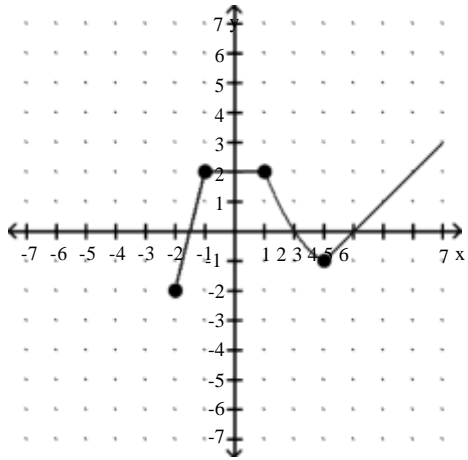

- A) domain: $[-2, 2]$; range: $[-2, \infty)$
- B) domain: $[-2, \infty)$; range: $[-2, 2]$
- C) domain: $[-2, \infty)$; range: $[-2, \infty)$
- D) domain: $(-2, \infty)$; range: $(-2, \infty)$

Answer: C

12)

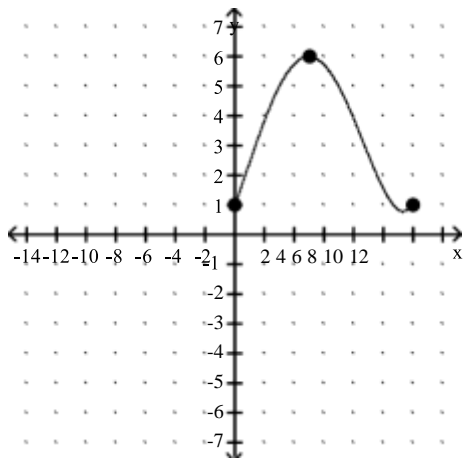

- A) domain: $(1, 6)$; range: $(0, 12)$
- B) domain: $[0, 12]$; range: $[1, 6]$
- C) domain: $[1, 6]$; range: $[0, 12]$
- D) domain: $(0, 12)$; range: $(1, 6)$

Answer: B

Using the graph, determine any relative maxima or minima of the function and the intervals on which the function is increasing or decreasing. Round to three decimal places when necessary.

13) $f(x) = x^2 - 6x + 7$

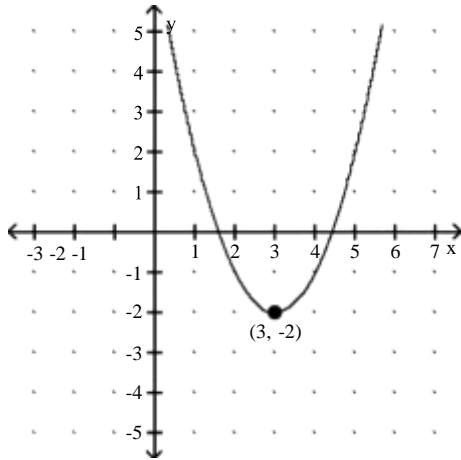

- A) relative maximum: 3 at $y = -2$; increasing $(-\infty, 3)$; decreasing $(3, \infty)$
- B) relative maximum: -2 at $x = 3$; increasing $(3, \infty)$; decreasing $(-\infty, 3)$
- C) relative minimum: 3 at $y = -2$; increasing $(-\infty, 3)$; decreasing $(3, \infty)$
- D) relative minimum: -2 at $x = 3$; increasing $(3, \infty)$; decreasing $(-\infty, 3)$

Answer: D

14) $f(x) = x^3 - 3x^2 + 1$

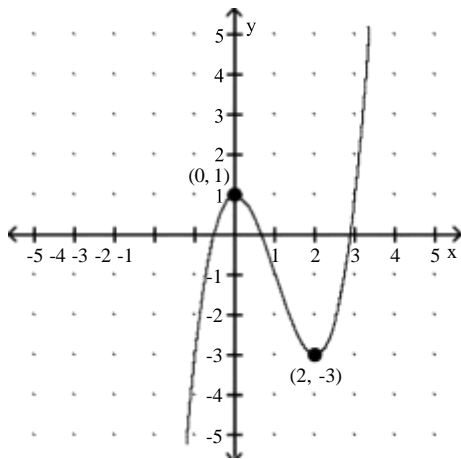

- A) no relative maxima; relative minimum: -3 at $x = 2$; increasing $(-\infty, 0), (2, \infty)$; decreasing $(0, 2)$
- B) relative maximum: 1 at $x = 0$; no relative minima; increasing $(-\infty, 0), (2, \infty)$; decreasing $(0, 2)$
- C) relative maximum: -3 at $x = 2$; relative minimum: 1 at $x = 0$; increasing $(0, 2)$; decreasing $(-\infty, 0), (2, \infty)$
- D) relative maximum: 1 at $x = 0$; relative minimum: -3 at $x = 2$; increasing $(-\infty, 0), (2, \infty)$; decreasing $(0, 2)$

Answer: D

15) $f(x) = x^3 - 12x + 2$

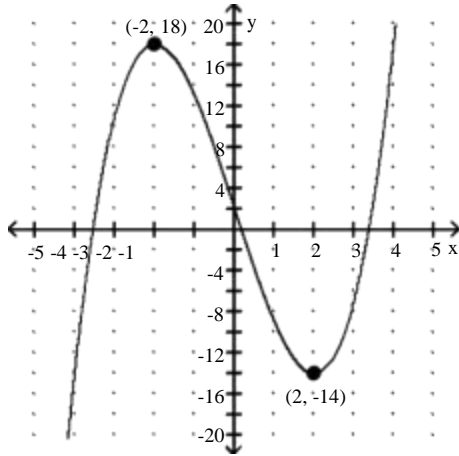

- A) relative maximum: 18 at $x = -2$; relative minimum: -14 at $x = 2$; increasing $(-\infty, -2)$, $(2, \infty)$; decreasing $(-2, 2)$
- B) no relative maxima or minima; increasing $(-\infty, -2)$, $(2, \infty)$; decreasing $(-2, 2)$
- C) relative maxima: 18 at $x = -2$ and 0 at $x = 0$; relative minimum: -14 at $x = 2$; increasing $(-\infty, -2)$, $(2, \infty)$; decreasing $(-2, 2)$
- D) relative maximum: -14 at $x = 2$; relative minimum: 18 at $x = -2$; increasing $(-2, 2)$; decreasing $(-\infty, -2)$, $(2, \infty)$

Answer: A

16) $f(x) = -\frac{1}{2}x^3 + \frac{1}{2}x^2 - x + 1$

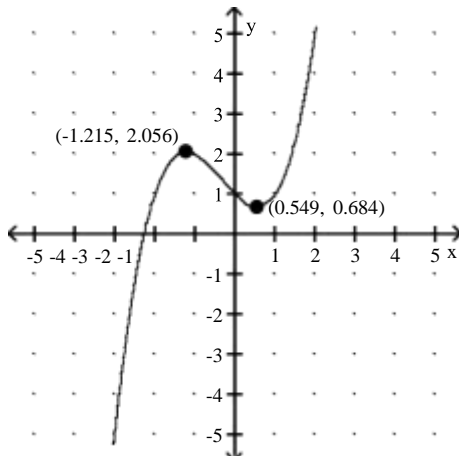

- A) no relative maxima or minima; increasing $(-\infty, -1.215)$, $(0.549, \infty)$; decreasing $(-1.215, 0.549)$
- B) relative maximum: 2.056 at $x = -1.215$; relative minimum: 0.684 at $x = 0.549$; increasing $(-\infty, -1.215)$, $(0.549, \infty)$; decreasing $(-1.215, 0.549)$
- C) relative maximum: 0.684 at $x = 0.549$; relative minimum: 2.056 at $x = -1.215$; increasing $(-1.215, 0.549)$; decreasing $(-\infty, -1.215)$, $(0.549, \infty)$
- D) relative maximum: 2.056 at $x = -1.215$; relative minima: 0.684 at $x = 0.549$ and 1 at $x = 0$; increasing $(-1.215, 0.549)$; decreasing $(-\infty, -1.215)$, $(0.549, \infty)$

Answer: B

17) $f(x) = -0.06x^3 - 0.3x^2 + 0.1x + 3$

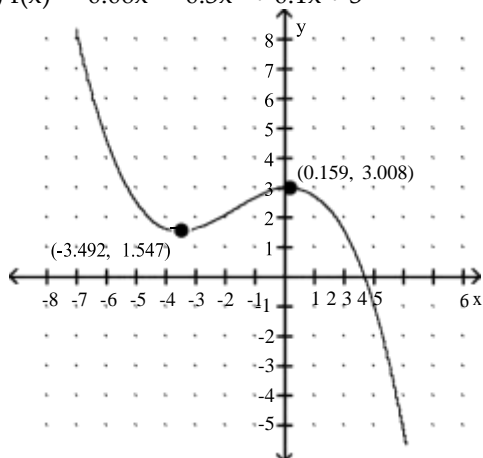

- A) relative maximum: 1.547 at $x = -3.492$; relative minimum: 3.008 at $x = 0.159$; increasing $(-3.492, 0.159)$; decreasing $(-\infty, -3.492), (0.159, \infty)$
- B) no relative maxima or minima; increasing $(-\infty, -3.492), (0.159, \infty)$; decreasing $(-3.492, 0.159)$
- C) relative maximum: 3.008 at $x = 0.159$; relative minimum: 1.547 at $x = -3.492$; increasing $(-3.492, 0.159)$; decreasing $(-\infty, -3.492), (0.159, \infty)$
- D) relative maxima: 3 at $x = 0$ and 3.008 at $x = 0.159$; relative minimum: 1.547 at $x = -3.492$; increasing $(-\infty, -3.492), (0.159, \infty)$; decreasing $(-3.492, 0.159)$

Answer: C

Graph the function. Use the graph to find any relative maxima or minima.

18) $f(x) = x^2 - 3$

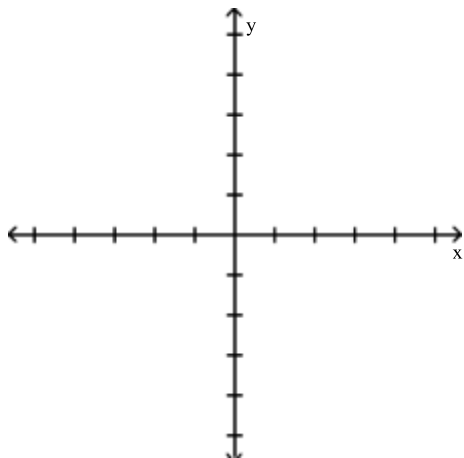

- A) Relative minimum of -3 at $x = 1$
- B) Relative minimum of -3 at $x = 0$
- C) No relative extrema
- D) Relative maximum of -3 at $x = 0$

Answer: B

19) $f(x) = -x^2 + 2$

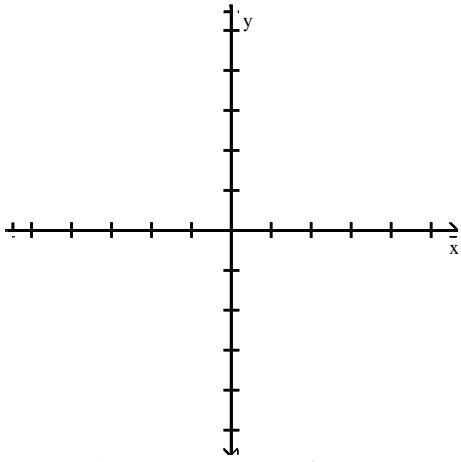

- A) Relative maximum of 2 at $x = 0$
- B) Relative maximum of 2 at $x = 0$ and relative minimum at $x = 3$
- C) No relative extrema
- D) Relative minimum of 2 at $x = 0$

Answer: A

20) $f(x) = -x^2 + 6x - 7$

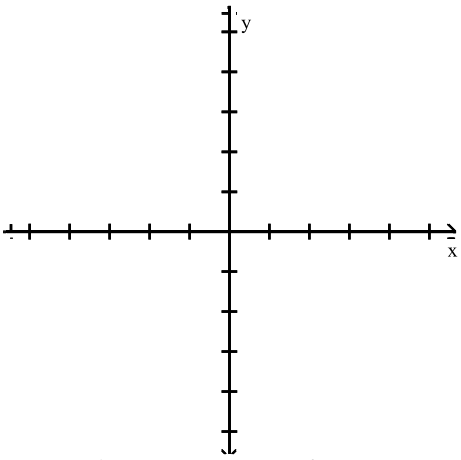

- A) Relative maximum of 3 at $x = 2$
- B) No relative extrema
- C) Relative maximum of 2 at $x = 3$
- D) Relative minimum of 2 at $x = 3$

Answer: C

21) $f(x) = x^2 + 8x + 14$

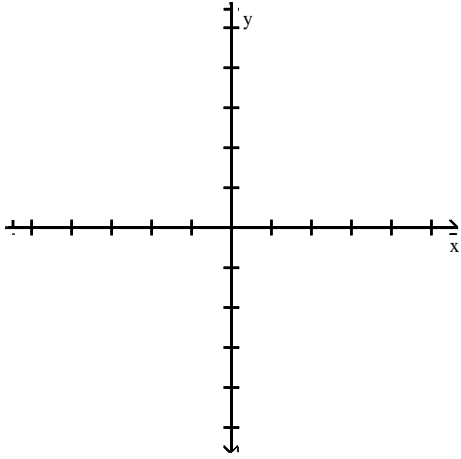

- A) Relative minimum of -2.2 at $x = -4.1$
- B) Relative maximum of -2.2 at $x = -4.1$
- C) Relative minimum of -2 at $x = -4$
- D) Relative maximum of -2 at $x = -4$

Answer: C

22) $f(x) = 4 - |x|$

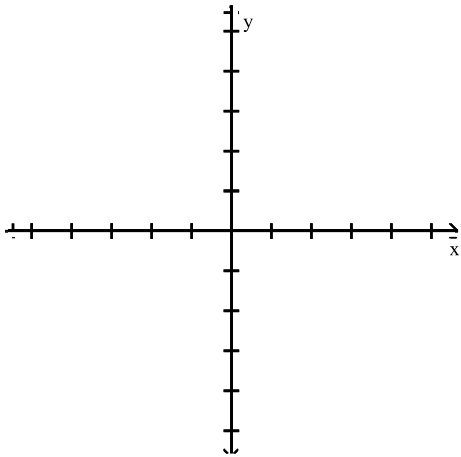

- A) Relative minimum of 4 at $x = 0$
- B) Relative maximum of 4.5 at $x = 0$
- C) Relative maximum of 4 at $x = 0$
- D) No relative extrema

Answer: C

23) $f(x) = |x + 4| - 2$

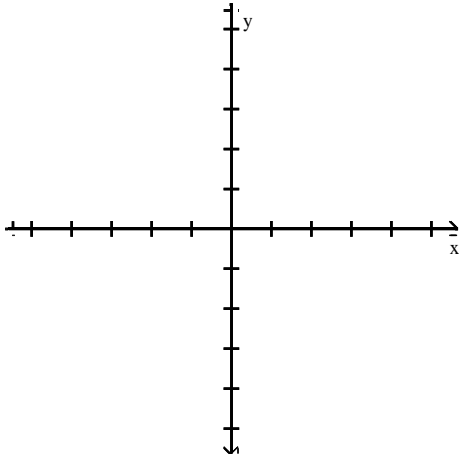

- A) Relative maximum of 2 at $x = -4$
- B) Relative minimum of 1.7 at $x = -4$
- C) Relative minimum of -2 at $x = -4$
- D) Relative minimum of 2.2 at $x = -4$

Answer: C

Solve.

24) Elissa wants to set up a rectangular dog run in her backyard. She has 34 feet of fencing to work with and wants to use it all. If the dog run is to be x feet long, express the area of the dog run as a function of x .

- A) $A(x) = 18x - x^2$
- B) $A(x) = 16x - x^2$
- C) $A(x) = 19x^2 - x$
- D) $A(x) = 17x - x^2$

Answer: D

25) Bob wants to fence in a rectangular garden in his yard. He has 70 feet of fencing to work with and wants to use it all. If the garden is to be x feet wide, express the area of the garden as a function of x .

- A) $A(x) = 37x^2 - x$
- B) $A(x) = 34x - x^2$
- C) $A(x) = 35x - x^2$
- D) $A(x) = 36x - x^2$

Answer: C

26) A rocket is shot straight up in the air from the ground at a rate of 53 feet per second. The rocket is tracked by a rangefinder that is 499 feet from the launch pad. Let d represent the distance from the rocket to the rangefinder and t represent the time, in seconds, since "blastoff". Express d as a function of t .

- A) $d(t) = 499 + 53t^2$
- B) $d(t) = \sqrt{499^2 + (53t)^2}$
- C) $d(t) = 499^2 + (53t)^2$
- D) $d(t) = \sqrt{53^2 + (499t)^2}$

Answer: B

27) Sue wants to put a rectangular garden on her property using 90 meters of fencing. There is a river that runs through her property so she decides to increase the size of the garden by using the river as one side of the rectangle. (Fencing is then needed only on the other three sides.) Let x represent the length of the side of the rectangle along the river. Express the garden's area as a function of x .

A) $A(x) = 44x - \frac{1}{4}x^2$

B) $A(x) = 45x - \frac{1}{2}x^2$

C) $A(x) = 46x - 2x^2$

D) $A(x) = 45x^2 - x$

Answer: B

28) A farmer's silo is the shape of a cylinder with a hemisphere as the roof. If the height of the silo is 94 feet and the radius of the hemisphere is r feet, express the volume of the silo as a function of r .

A) $V(r) = \pi(94 - r) + \frac{4}{3}\pi r^2$

B) $V(r) = 94\pi r^2 + \frac{8}{3}\pi r^3$

C) $V(r) = \pi(94 - r)r^2 + \frac{2}{3}\pi r^3$

D) $V(r) = \pi(94 - r)r^3 + \frac{4}{3}\pi r^2$

Answer: C

29) A farmer's silo is the shape of a cylinder with a hemisphere as the roof. If the radius of the hemisphere is 10 feet and the height of the silo is h feet, express the volume of the silo as a function of h .

A) $V(h) = 4100\pi(h - 10) + \frac{500}{7}\pi$

B) $V(h) = 100\pi(h - 10) + \frac{2000}{3}\pi$

C) $V(h) = 100\pi(h^2 - 10) + \frac{5000}{3}\pi$

D) $V(h) = 100\pi h + \frac{4000}{3}\pi h^2$

Answer: B

30) A rectangular sign is being designed so that the length of its base, in feet, is 8 feet less than 4 times the height, h . Express the area of the sign as a function of h .

A) $A(h) = -8h^2 + 2h$

B) $A(h) = -8h + h^2$

C) $A(h) = 8h - 2h^2$

D) $A(h) = -8h + 4h^2$

Answer: D

31) From a 20-inch by 20-inch piece of metal, squares are cut out of the four corners so that the sides can then be folded up to make a box. Let x represent the length of the sides of the squares, in inches, that are cut out. Express the volume of the box as a function of x .

A) $V(x) = 2x^3 - 60x^2$

B) $V(x) = 4x^3 - 80x^2$

C) $V(x) = 2x^3 - 60x^2 + 20x$

D) $V(x) = 4x^3 - 80x^2 + 400x$

Answer: D

32) A rectangular box with volume 233 cubic feet is built with a square base and top. The cost is \$1.50 per square foot for the top and the bottom and \$2.00 per square foot for the sides. Let x represent the length of a side of the base. Express the cost of the box as a function of x .

A) $C(x) = 2x^2 + \frac{1864}{x}$

B) $C(x) = 4x + \frac{1864}{x^2}$

C) $C(x) = 3x^2 + \frac{932}{x}$

D) $C(x) = 3x^2 + \frac{1864}{x}$

Answer: D

33) A rectangle that is x feet wide is inscribed in a circle of radius 27 feet. Express the area of the rectangle as a function of x .

A) $A(x) = x\sqrt{2187 - x}$

B) $A(x) = x^2\sqrt{458 - x^2}$

C) $A(x) = x(2916 - x^2)$

D) $A(x) = x\sqrt{2916 - x^2}$

Answer: D

34) From a 15-inch by 15-inch piece of metal, squares are cut out of the four corners so that the sides can then be folded up to make a box. Let x represent the length of the sides of the squares, in inches, that are cut out. Express the volume of the box as a function of x . Graph the function and from the graph determine the value of x , to the nearest tenth of an inch, that will yield the maximum volume.

A) 2.3 inches

B) 2.8 inches

C) 2.5 inches

D) 3.1 inches

Answer: C

- 35) From a 24-inch by 24-inch piece of metal, squares are cut out of the four corners so that the sides can then be folded up to make a box. Let x represent the length of the sides of the squares, in inches, that are cut out. Express the volume of the box as a function of x . Graph the function and from the graph determine the value of x , to the nearest tenth of an inch, that will yield the maximum volume.
- A) 3.8 inches
 - B) 4.0 inches
 - C) 3.7 inches
 - D) 4.1 inches

Answer: B

- 36) A rectangular box with volume 468 cubic feet is built with a square base and top. The cost is \$1.50 per square foot for the top and the bottom and \$2.00 per square foot for the sides. Let x represent the length of a side of the base in feet. Express the cost of the box as a function of x and then graph this function. From the graph find the value of x , to the nearest hundredth of a foot, which will minimize the cost of the box.
- A) 7.92 feet
 - B) 8.63 feet
 - C) 8.55 feet
 - D) 8.44 feet

Answer: C

- 37) A rectangular box with volume 517 cubic feet is built with a square base and top. The cost is \$1.50 per square foot for the top and the bottom and \$2.00 per square foot for the sides. Let x represent the length of a side of the base in feet. Express the cost of the box as a function of x and then graph this function. From the graph find the value of x , to the nearest hundredth of a foot, which will minimize the cost of the box.
- A) 8.49 feet
 - B) 8.79 feet
 - C) 8.83 feet
 - D) 8.91 feet

Answer: C

- 38) A rectangle that is x feet wide is inscribed in a circle of radius 20 feet. Express the area of the rectangle as a function of x . Graph the function and from the graph determine the value of x , to the nearest tenth of a foot, which will maximize the area of the rectangle.
- A) 28.3 feet
 - B) 29.1 feet
 - C) 27.9 feet
 - D) 28.7 feet

Answer: A

- 39) A rectangle that is x feet wide is inscribed in a circle of radius 32 feet. Express the area of the rectangle as a function of x . Graph the function and from the graph determine the value of x , to the nearest tenth of a foot, which will maximize the area of the rectangle.
- A) 44.5 feet
 - B) 45.3 feet
 - C) 44.9 feet
 - D) 45.7 feet

Answer: B

- 40) Elissa sells two breeds of dogs, Alaskan Malamutes and Great Pyrenees. She has 92 feet of fencing to enclose two adjacent rectangular dog kennels, one for each breed. An existing fence is to form one side of the kennels, as in the drawing below. Suppose the total length of the two kennels is x feet. Express the total area of the two kennels as a function of x . Graph the function and from the graph determine the value of x that will yield the maximum area.

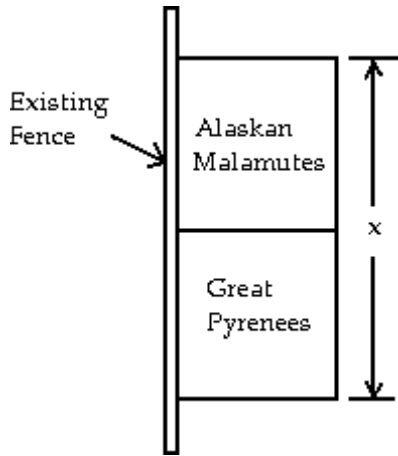

- A) 46 feet
 B) 48 feet
 C) $46\frac{1}{2}$ feet
 D) 45 feet

Answer: A

- 41) Elissa sells two breeds of dogs, Alaskan Malamutes and Great Pyrenees. She has 114 feet of fencing to enclose two adjacent rectangular dog kennels, one for each breed. An existing fence is to form one side of the kennels, as in the drawing below. Let x represent the measurement indicated. Express the total area of the two kennels as a function of x . Graph the function and from the graph determine the value of x , rounded to the hundredths place, that will yield the maximum area.

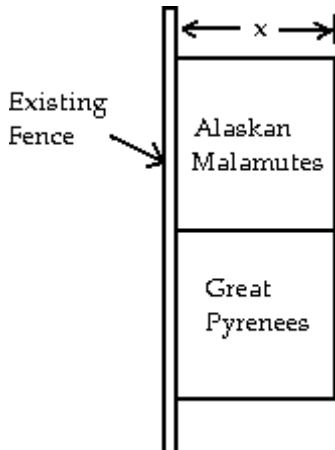

- A) 28.50 feet
 B) 19.33 feet
 C) 19.17 feet
 D) 19.00 feet

Answer: D

For the piecewise function, find the specified function value.

$$42) f(x) = \begin{cases} 9x, & \text{for } x \leq -1, \\ x - 2, & \text{for } x > -1 \end{cases}$$

$f(-8)$

- A) -72
- B) -10
- C) 6
- D) 72

Answer: A

$$43) f(x) = \begin{cases} x - 8, & \text{for } x < 2, \\ 4 - x, & \text{for } x \geq 2 \end{cases}$$

$f(0)$

- A) -8
- B) -6
- C) 2
- D) 4

Answer: A

$$44) f(x) = \begin{cases} 4x + 7, & \text{for } x \leq 0, \\ 7 - 4x, & \text{for } 0 < x < 4, \\ x, & \text{for } x \geq 4 \end{cases}$$

$f(5)$

- A) -13
- B) 4
- C) 27
- D) 5

Answer: D

$$45) f(x) = \begin{cases} 6x + 1, & \text{for } x < 1, \\ 7x, & \text{for } 7 \leq x \leq 9, \\ 7 - 5x, & \text{for } x > 9 \end{cases}$$

$f(7)$

- A) 7
- B) -28
- C) 46
- D) 49

Answer: D

$$46) f(x) = \begin{cases} 4x + 1, & \text{for } x < 9, \\ 9x, & \text{for } 9 \leq x \leq 12, \\ 9 - 5x, & \text{for } x > 12 \end{cases}$$

$f(-9)$

- A) -81
- B) -35
- C) 37
- D) 54

Answer: B

Graph the function.

$$47) f(x) = \begin{cases} 1, & \text{for } x \geq 1, \\ -3 - x, & \text{for } x < 1 \end{cases}$$

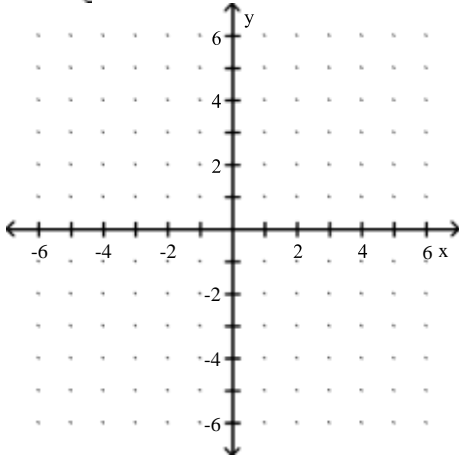

A)

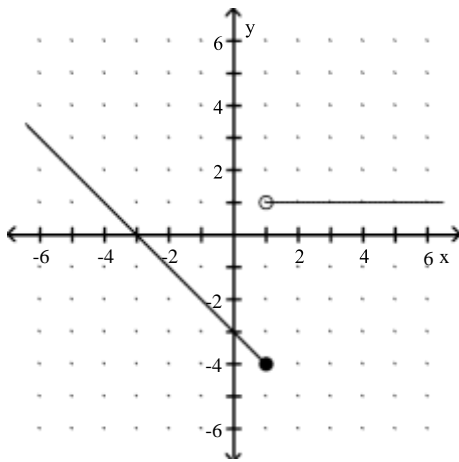

B)

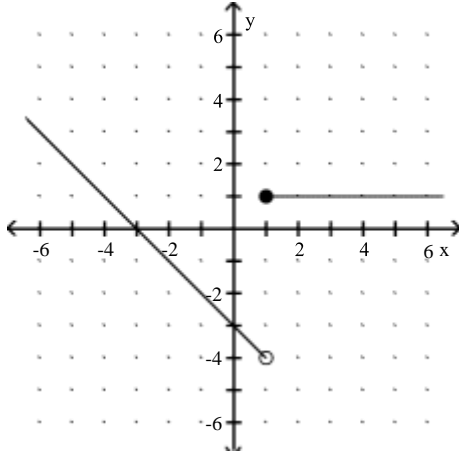

C)

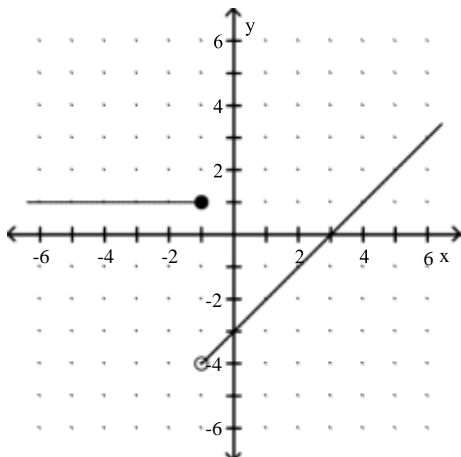

D)

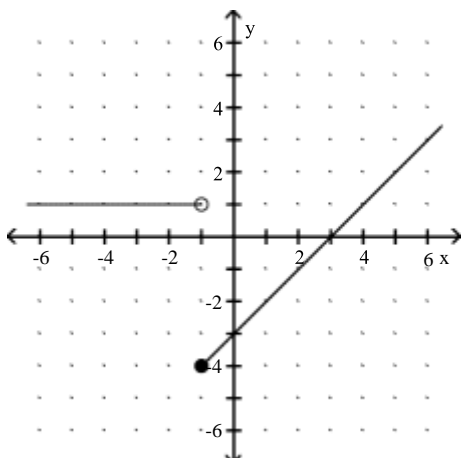

Answer: B

$$48) f(x) = \begin{cases} x - 5, & \text{for } x > 0, \\ 4, & \text{for } x \leq 0 \end{cases}$$

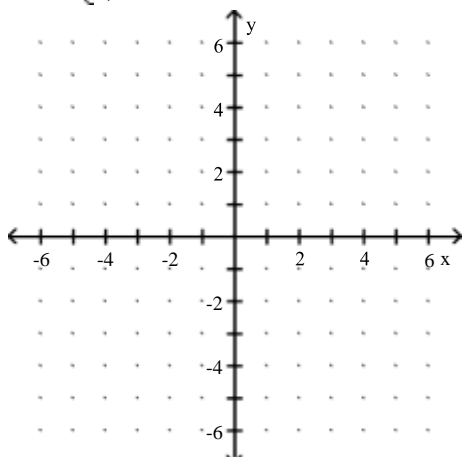

A)

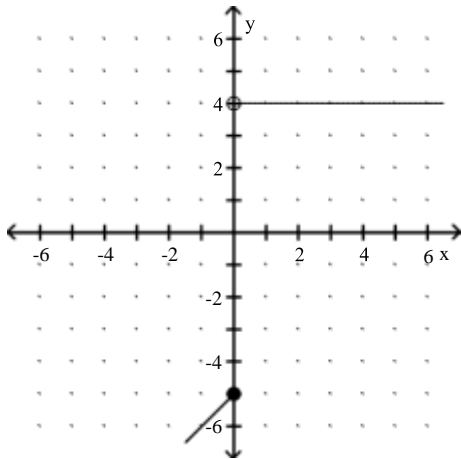

B)

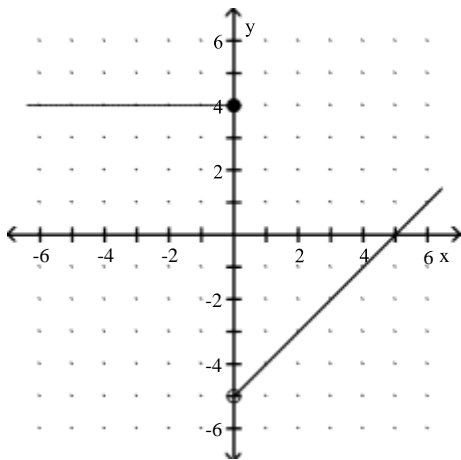

C)

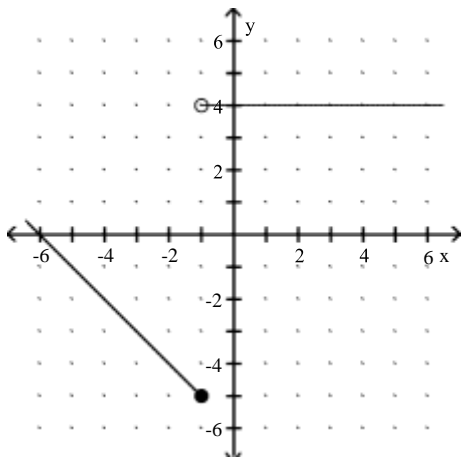

D)

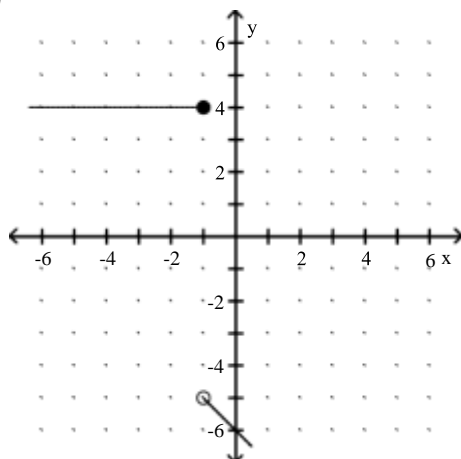

Answer: B

$$49) f(x) = \begin{cases} -1 - x, & \text{for } x \leq 2, \\ 1 + 3x, & \text{for } x > 2 \end{cases}$$

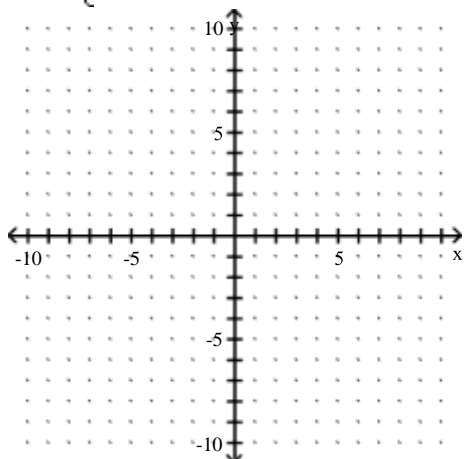

A)

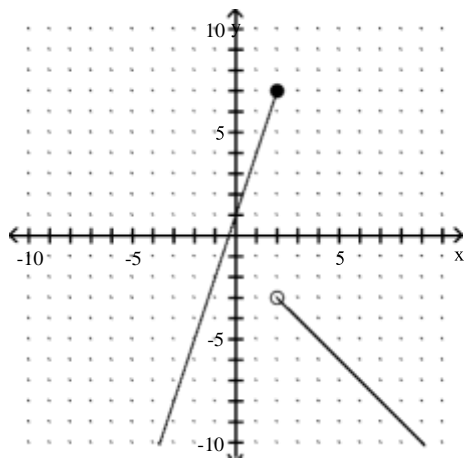

B)

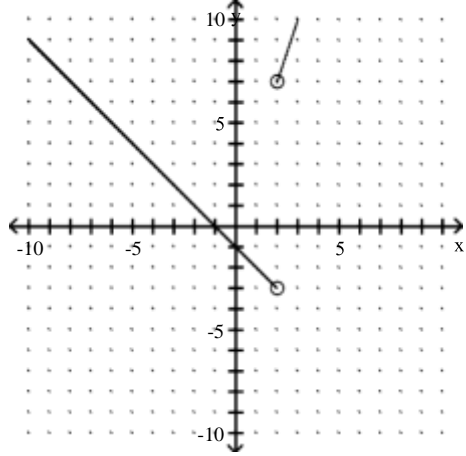

C)

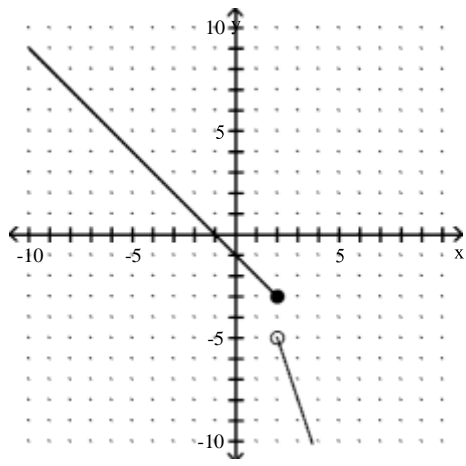

D)

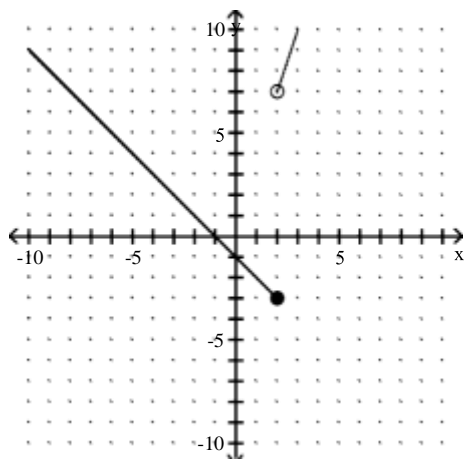

Answer: D

$$50) f(x) = \begin{cases} x + 2 & \text{for } -8 \leq x < 3 \\ -8 & \text{for } x = 3 \\ -x + 4 & \text{for } x > 3 \end{cases}$$

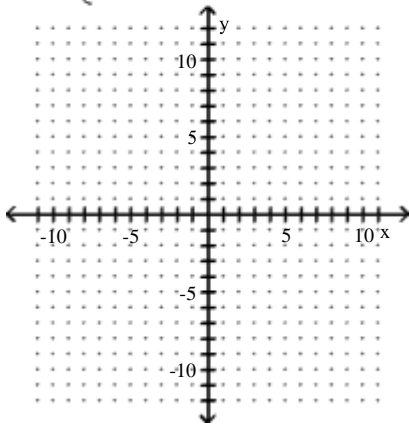

A)

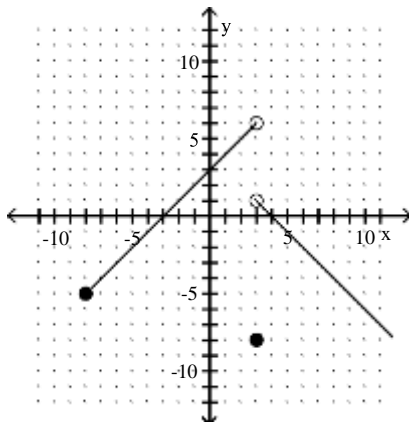

B)

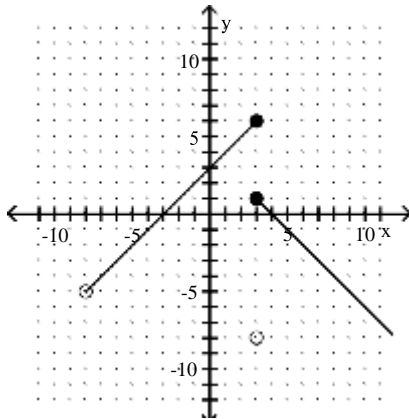

C)

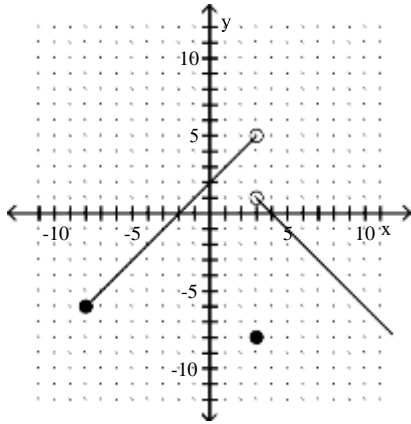

D)

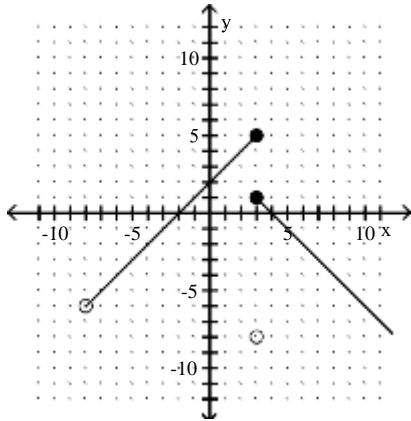

Answer: C

$$51) f(x) = \begin{cases} 3x + 2 & \text{for } x < -2 \\ x & \text{for } -2 \leq x \leq 3 \\ 2x - 1 & \text{for } x > 3 \end{cases}$$

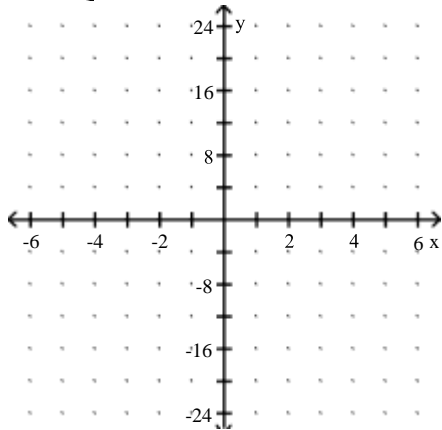

A)

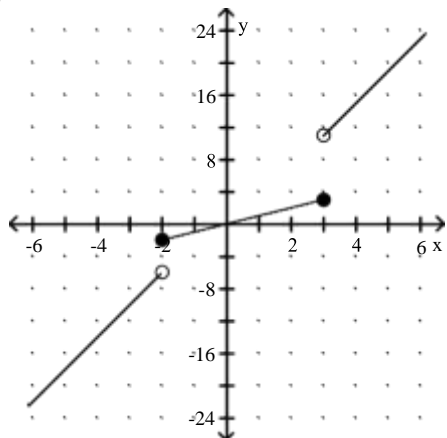

B)

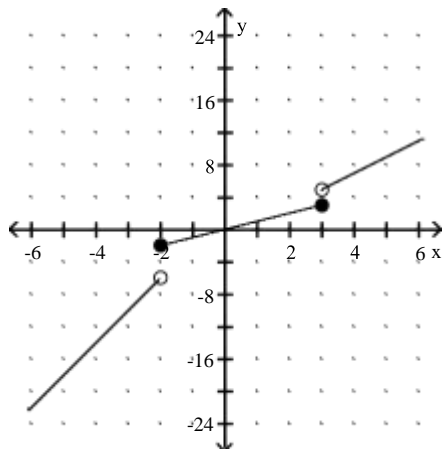

C)

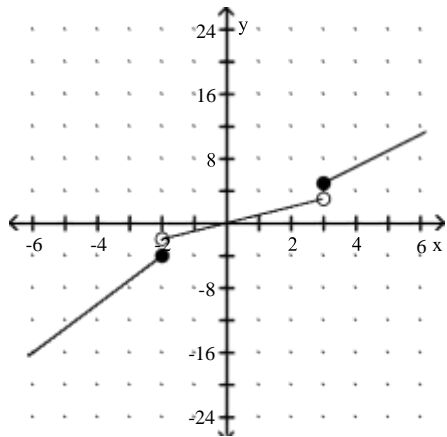

D)

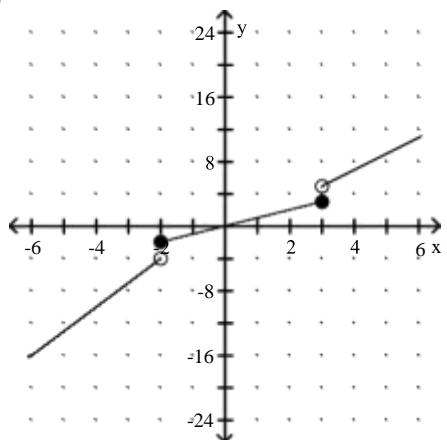

Answer: D

$$52) f(x) = \begin{cases} \frac{1}{x-2}, & \text{for } x \neq 2, \\ 2, & \text{for } x = 2 \end{cases}$$

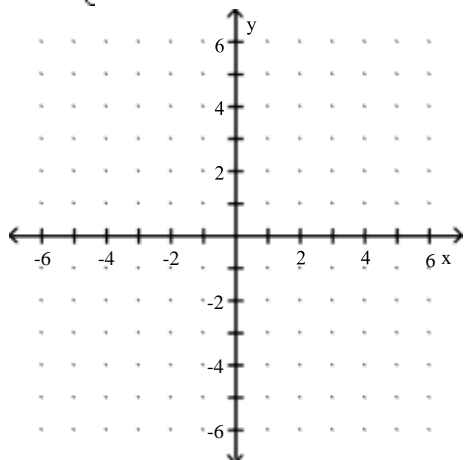

A)

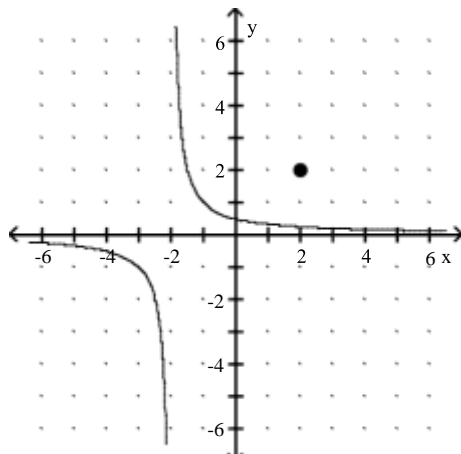

B)

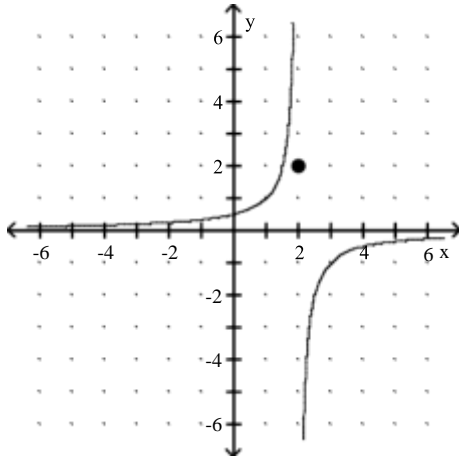

C)

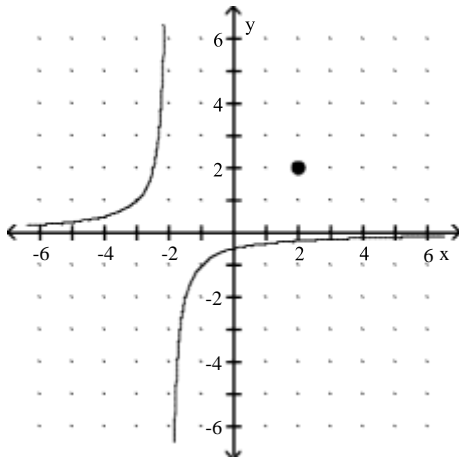

D)

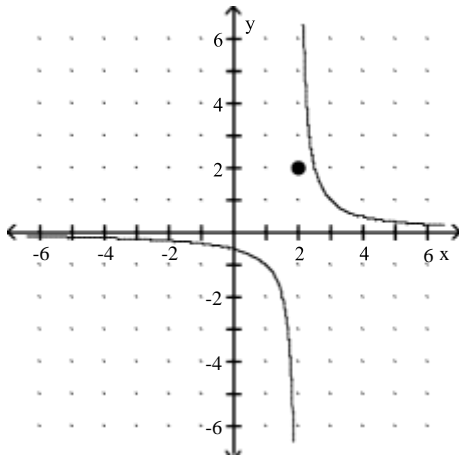

Answer: D

$$53) f(x) = \begin{cases} \frac{x^2 - 9}{x + 3}, & \text{for } x \neq -3, \\ 7, & \text{for } x = -3 \end{cases}$$

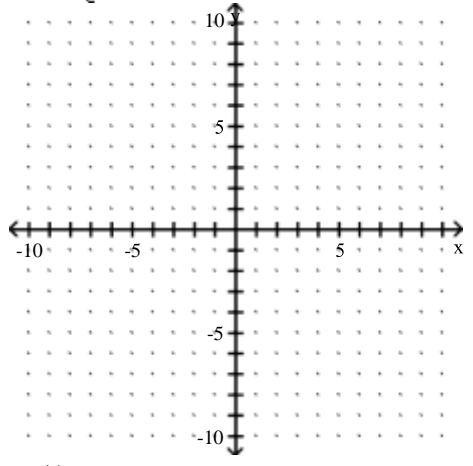

A)

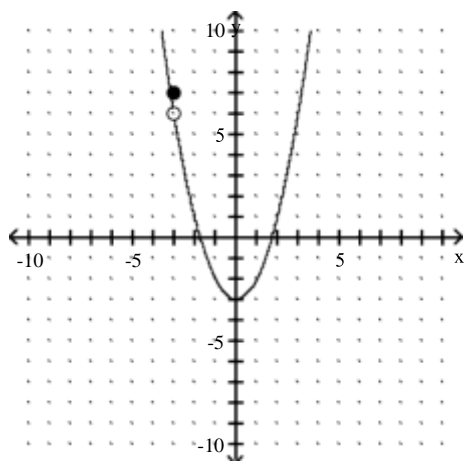

B)

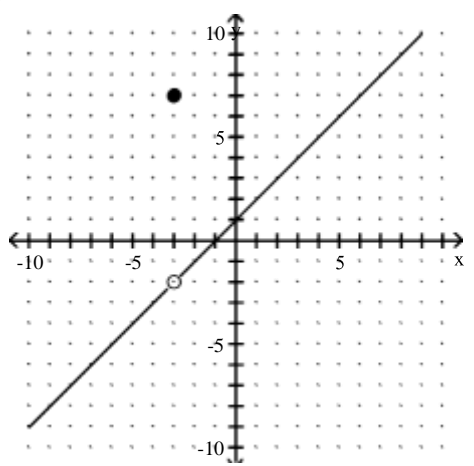

C)

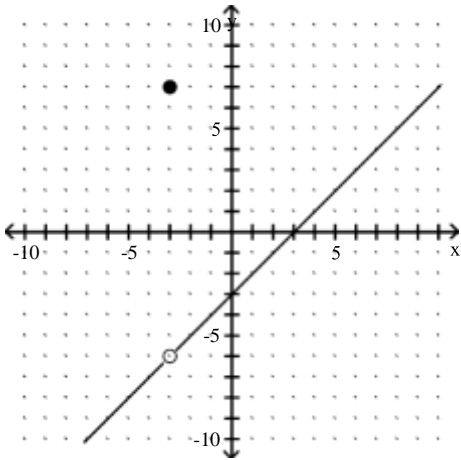

D)

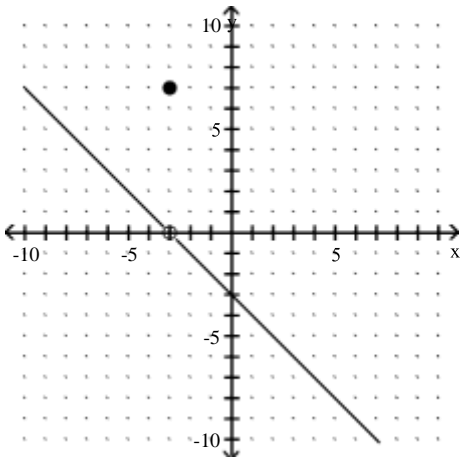

Answer: C

$$54) f(x) = \begin{cases} \frac{x^2 - 16}{x - 4}, & \text{for } x \neq 4, \\ -7, & \text{for } x = 4 \end{cases}$$

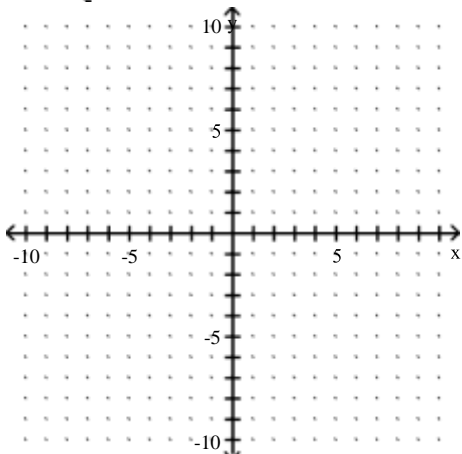

A)

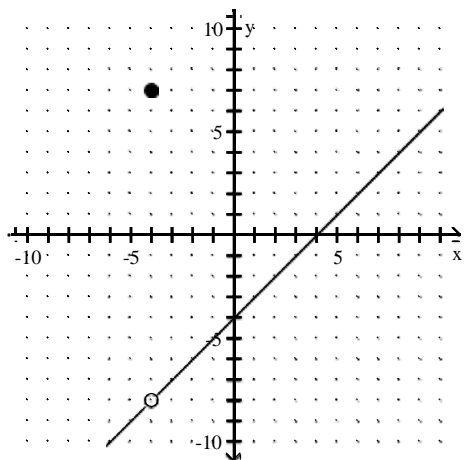

B)

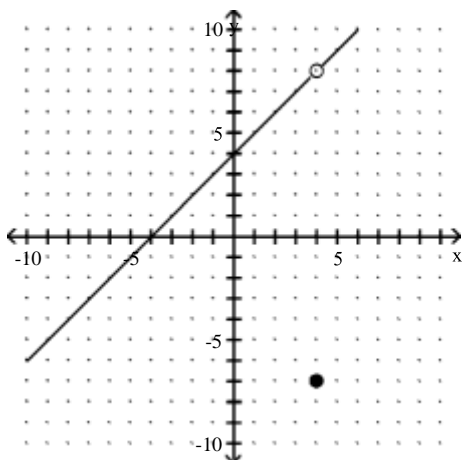

C)

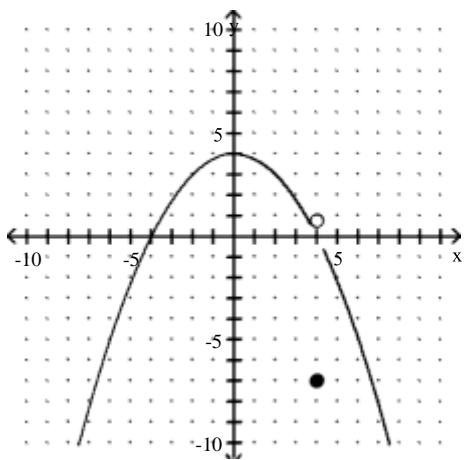

D)

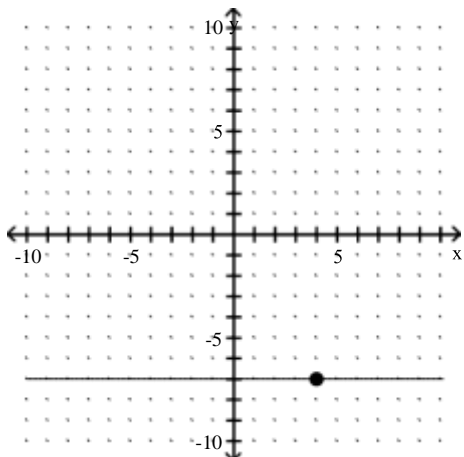

Answer: B

$$55) f(x) = \begin{cases} \frac{x^2 + 3x + 2}{x + 2}, & \text{for } x \neq -2, \\ -7, & \text{for } x = -2 \end{cases}$$

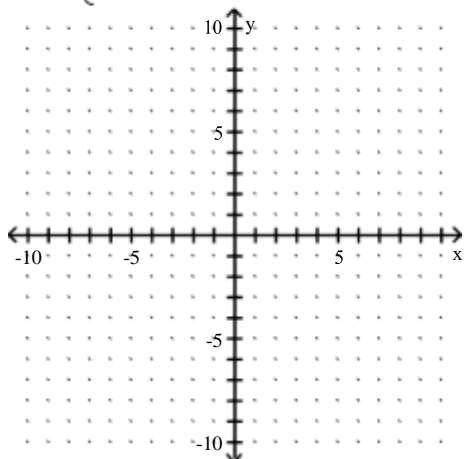

A)

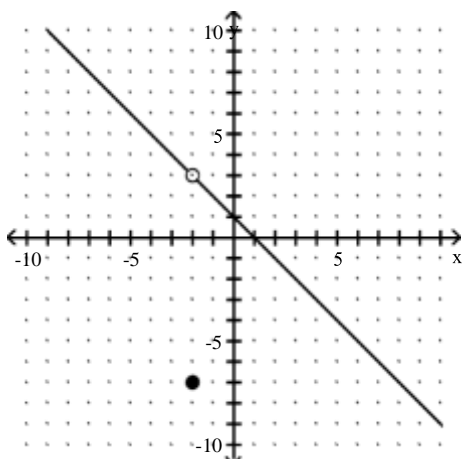

B)

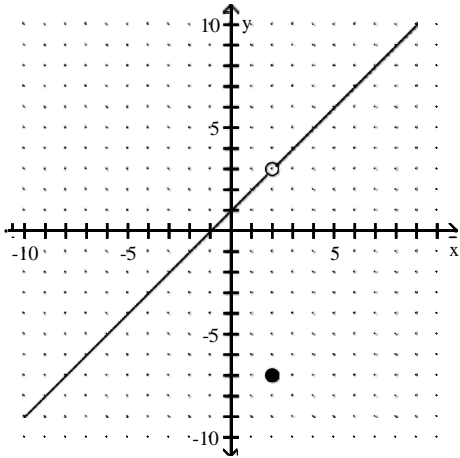

C)

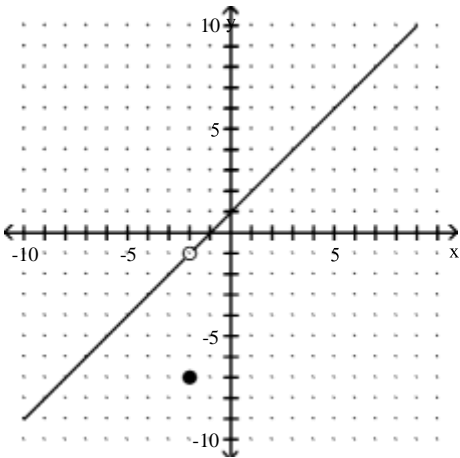

D)

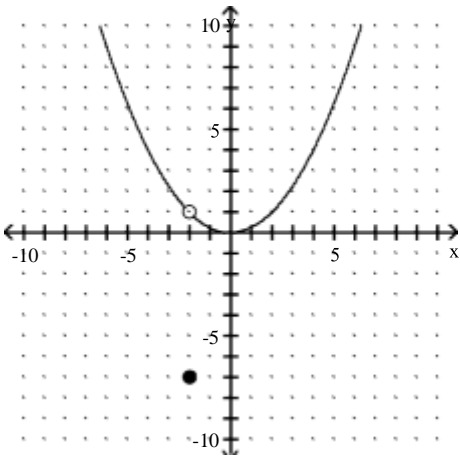

Answer: C

Graph the equation.

56) $y = \lfloor k \rfloor$

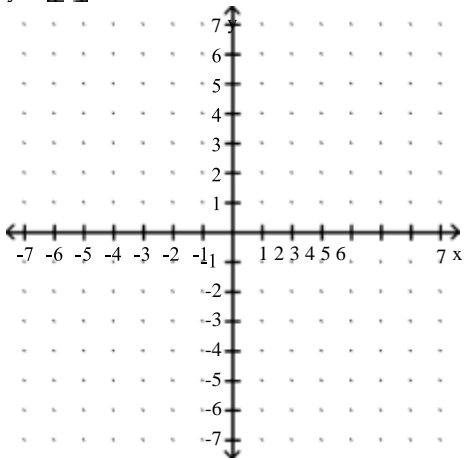

A)

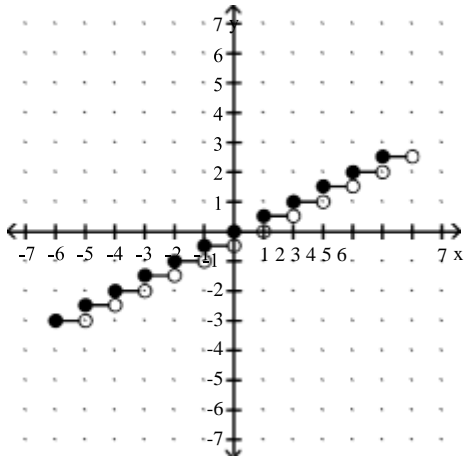

B)

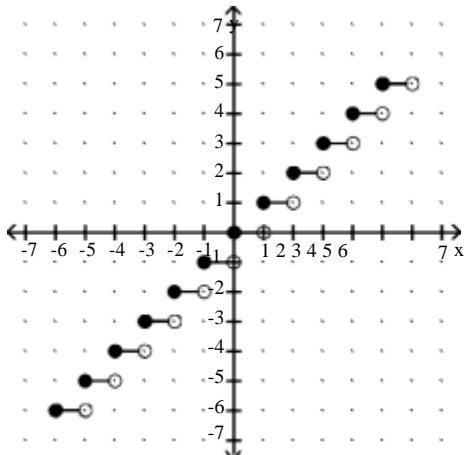

C)

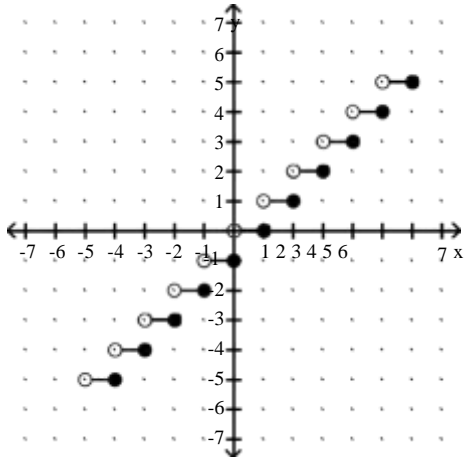

D)

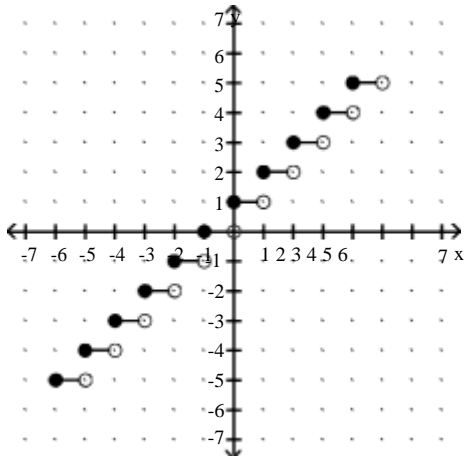

Answer: B

57) $y = \frac{1}{2}x$

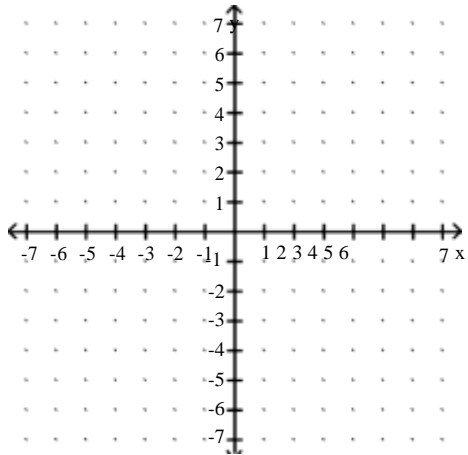

A)

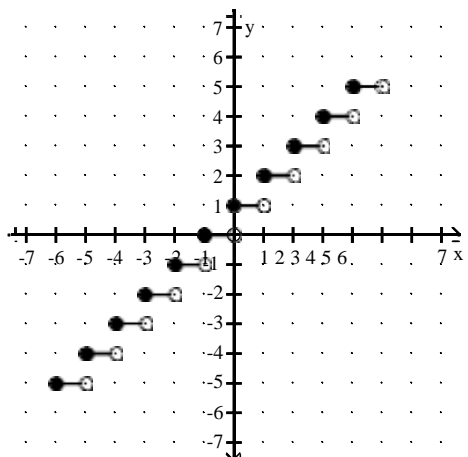

B)

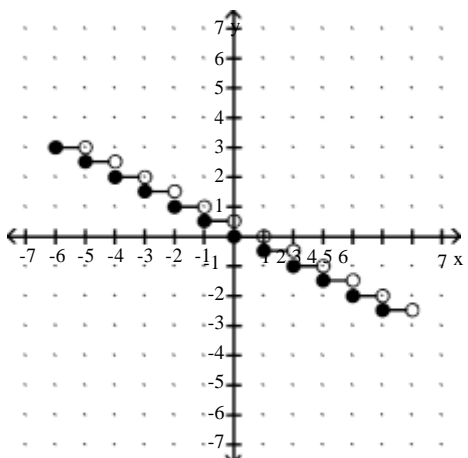

C)

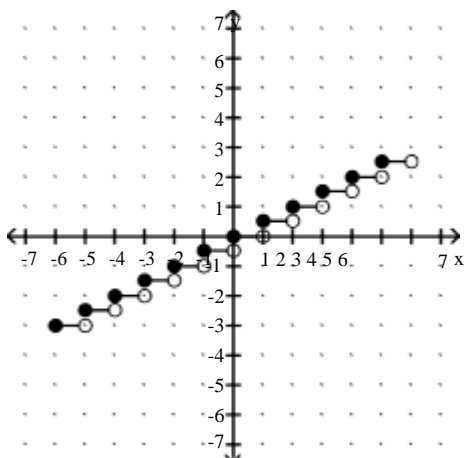

D)

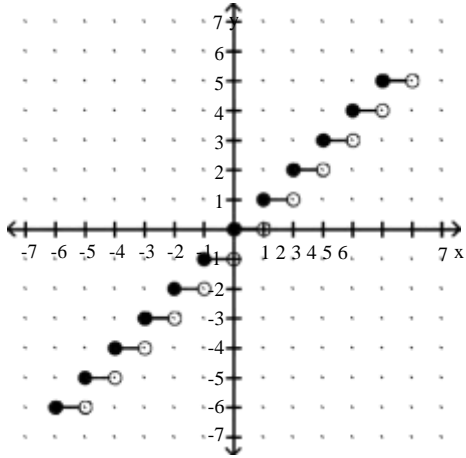

Answer: C

58) $y = 3 \lfloor x \rfloor$

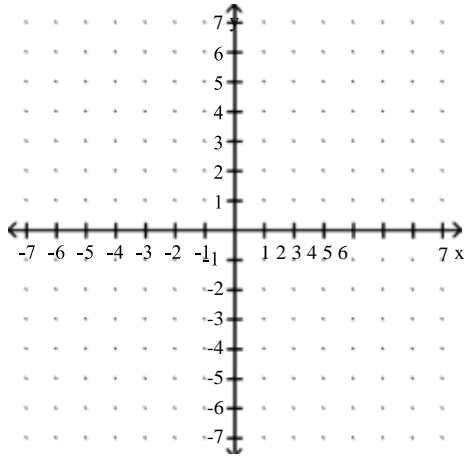

A)

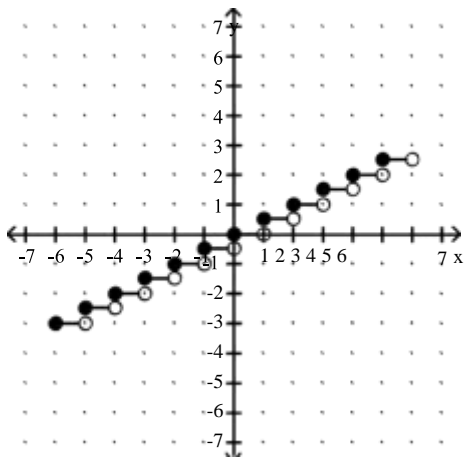

B)

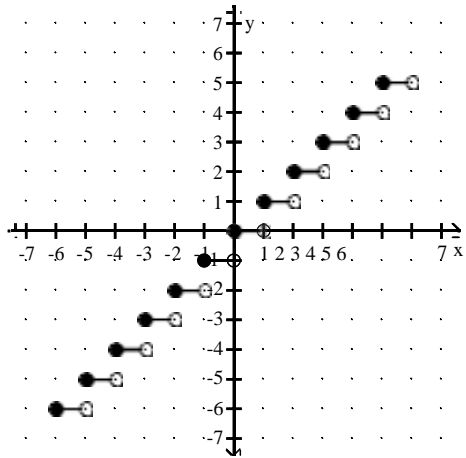

C)

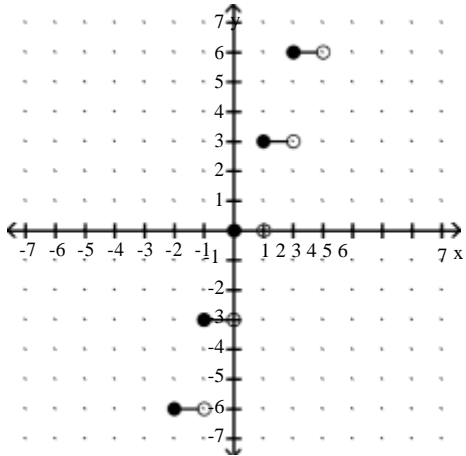

D)

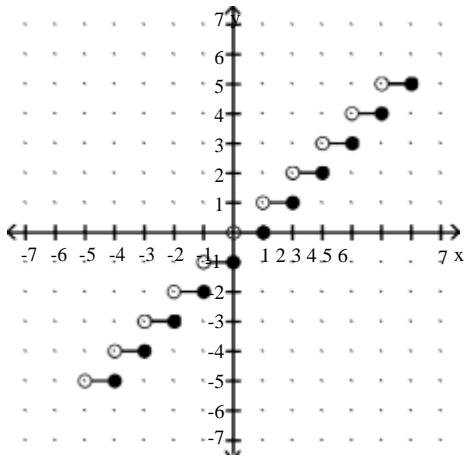

Answer: C

59) $y = 2\lfloor k \rfloor$

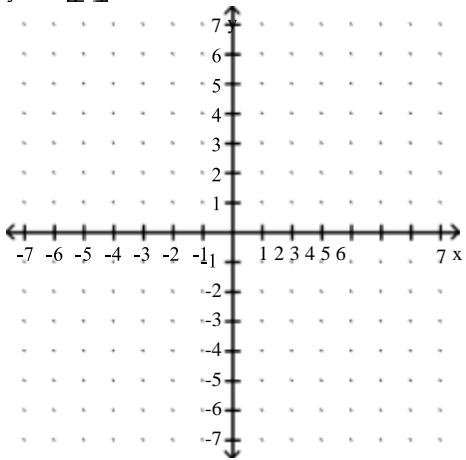

A)

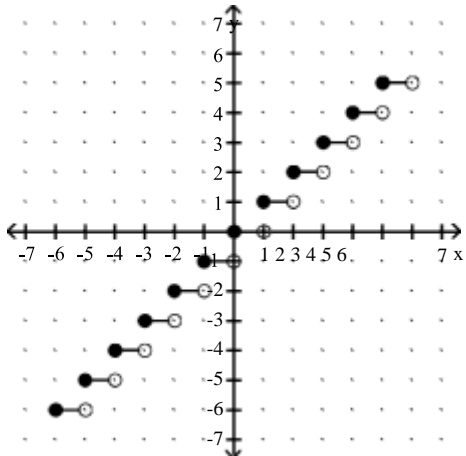

B)

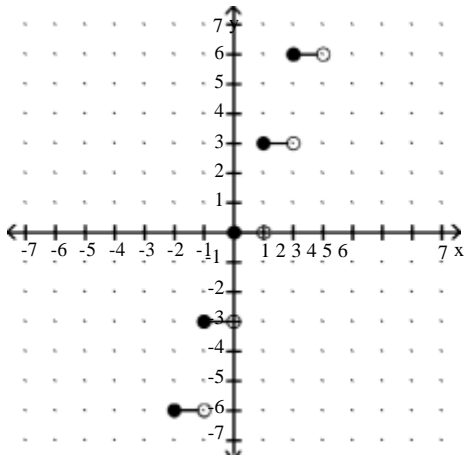

C)

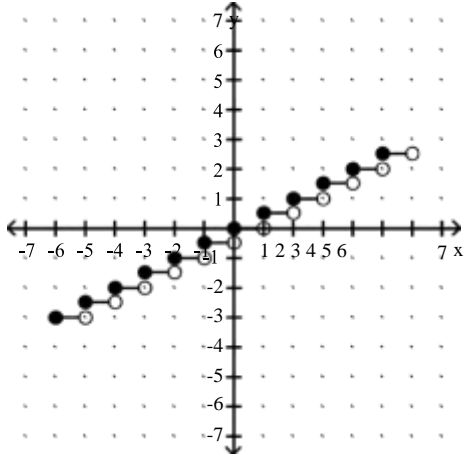

D)

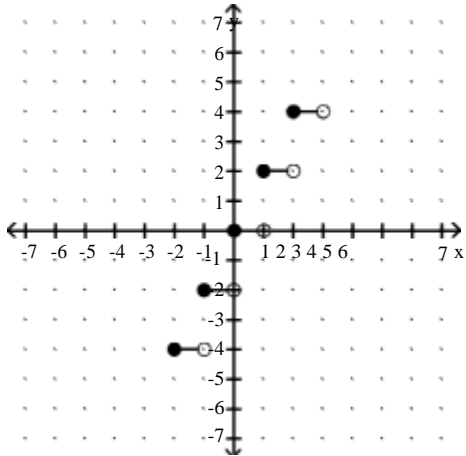

Answer: D

60) $y = 1 + \boxed{k}$

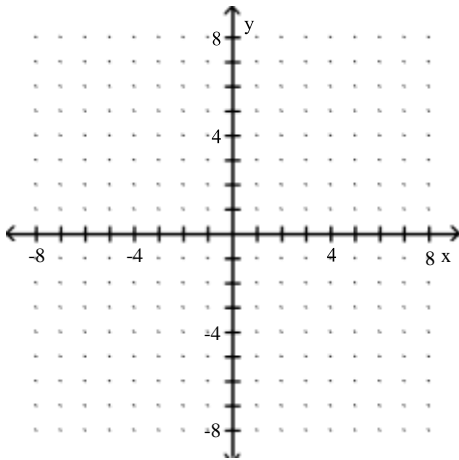

A)

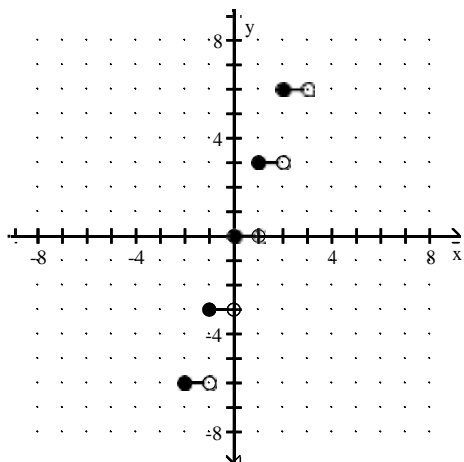

B)

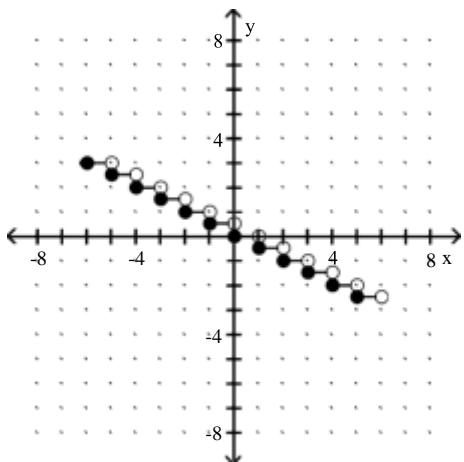

C)

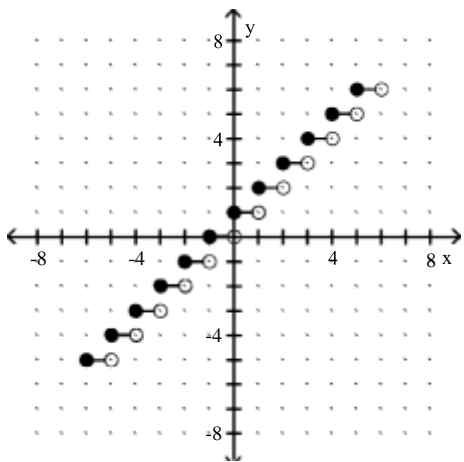

D)

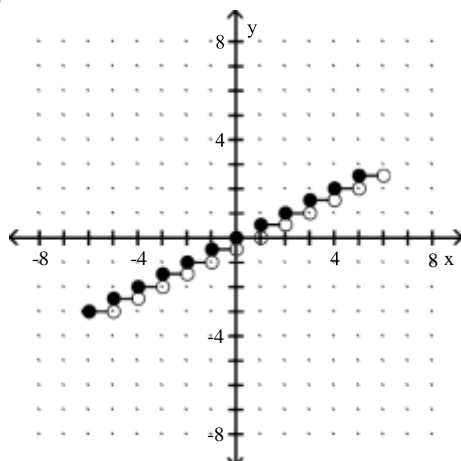

Answer: C

$$61) y = \frac{1}{2} \lfloor \lfloor x \rfloor \rfloor - 2$$

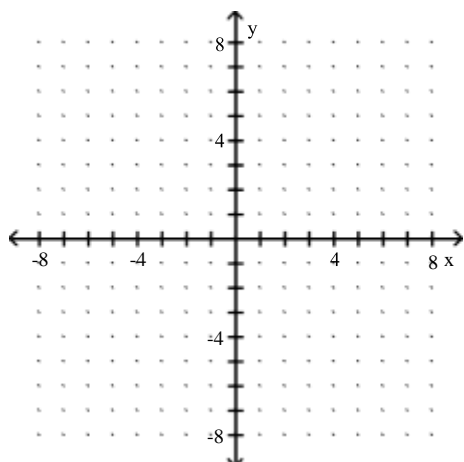

A)

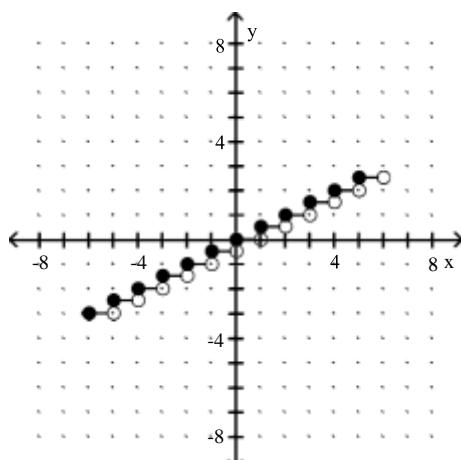

B)

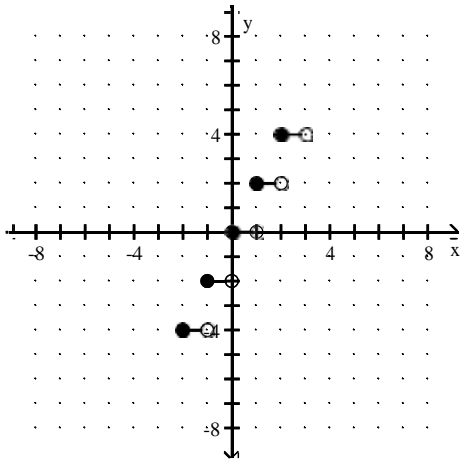

C)

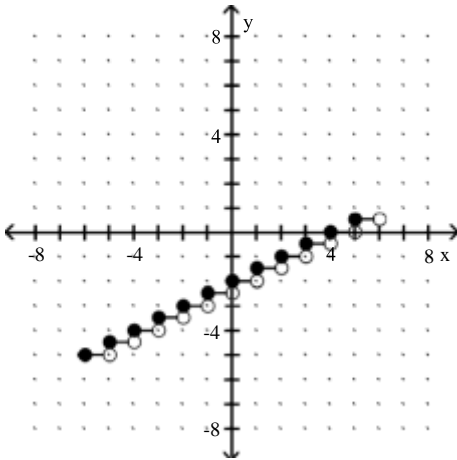

D)

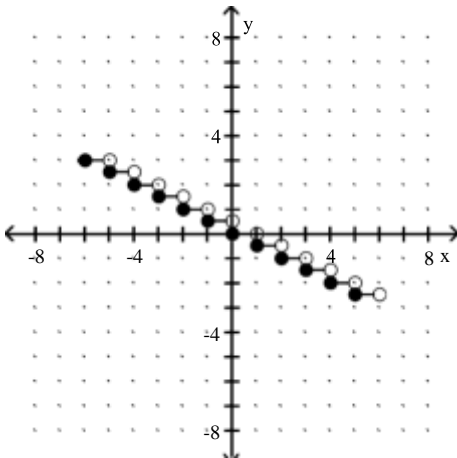

Answer: C

Write an equation for the piecewise function.

62)

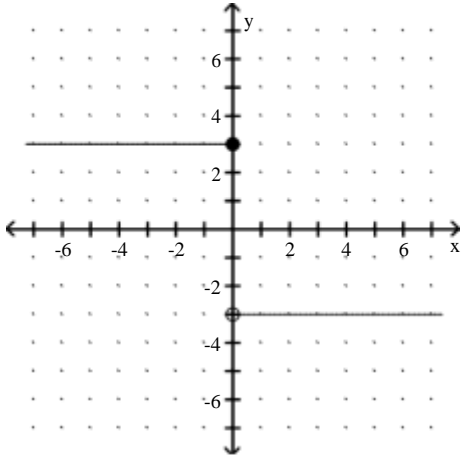

A) $f(x) = \begin{cases} -3, & \text{for } x \leq 0, \\ 3, & \text{for } x > 0 \end{cases}$

B) $f(x) = \begin{cases} 3, & \text{for } x \leq 0, \\ -3, & \text{for } x > 0 \end{cases}$

C) $f(x) = \begin{cases} 3x, & \text{for } x \leq 0, \\ -3x, & \text{for } x > 0 \end{cases}$

D) $f(x) = \begin{cases} 3, & \text{for } x < 0, \\ -3, & \text{for } x \geq 0 \end{cases}$

Answer: B

63)

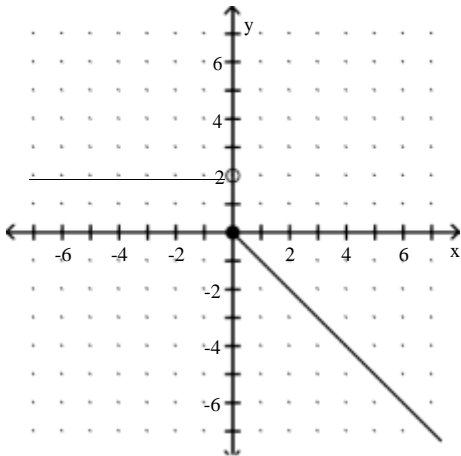

A) $f(x) = \begin{cases} 2, & \text{for } x < 0, \\ x, & \text{for } x \geq 0 \end{cases}$

B) $f(x) = \begin{cases} 2, & \text{for } x \leq 0, \\ -x, & \text{for } x > 0 \end{cases}$

C) $f(x) = \begin{cases} 2, & \text{for } x < 0, \\ -x, & \text{for } x \geq 0 \end{cases}$

D) $f(x) = \begin{cases} 2, & \text{for } x < 0, \\ -2x, & \text{for } x \geq 0 \end{cases}$

Answer: C

64)

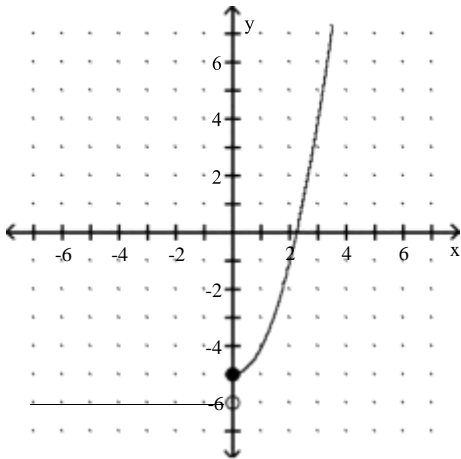

- A) $f(x) = \begin{cases} 6, & \text{for } x < 0, \\ x^2, & \text{for } x \geq 0 \end{cases}$
- B) $f(x) = \begin{cases} 6, & \text{for } x < 0, \\ |x| - 5, & \text{for } x \geq 0 \end{cases}$
- C) $f(x) = \begin{cases} 6, & \text{for } x \leq 0, \\ x^2 - 5, & \text{for } x > 0 \end{cases}$
- D) $f(x) = \begin{cases} -6, & \text{for } x < 0, \\ x^2 - 5, & \text{for } x \geq 0 \end{cases}$

Answer: D

65)

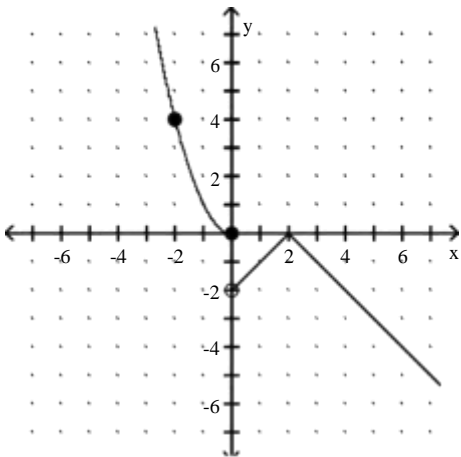

- A) $f(x) = \begin{cases} -x^2, & \text{for } x \leq 0, \\ |x - 2|, & \text{for } x > 0 \end{cases}$
- B) $f(x) = \begin{cases} x^2, & \text{for } x \leq 0, \\ -|x + 2|, & \text{for } x > 0 \end{cases}$
- C) $f(x) = \begin{cases} x^2, & \text{for } x \leq 0, \\ -|x - 2|, & \text{for } x > 0 \end{cases}$
- D) $f(x) = \begin{cases} -|x - 2|, & \text{for } x < 0, \\ x^2, & \text{for } x \geq 0 \end{cases}$

Answer: C

66)

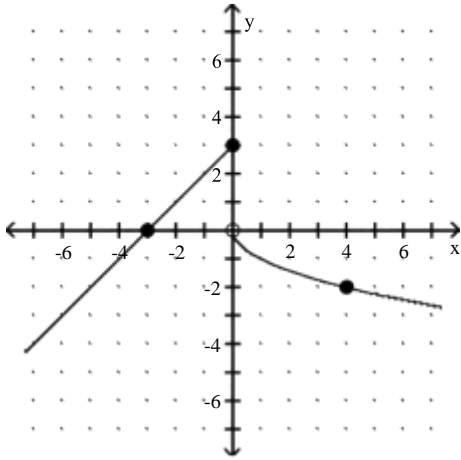

- A) $f(x) = \begin{cases} -x + 3, & \text{for } x \leq 0, \\ -\sqrt{x}, & \text{for } x > 0 \end{cases}$
- B) $f(x) = \begin{cases} x + 3, & \text{for } x \leq 0, \\ -\sqrt{x}, & \text{for } x > 0 \end{cases}$
- C) $f(x) = \begin{cases} x - 3, & \text{for } x \leq 0, \\ -x^2, & \text{for } x > 0 \end{cases}$
- D) $f(x) = \begin{cases} x + 3, & \text{for } x \leq 0, \\ \sqrt{x}, & \text{for } x > 0 \end{cases}$

Answer: B

67)

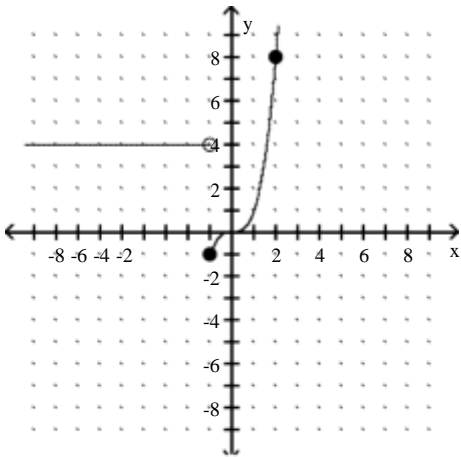

- A) $f(x) = \begin{cases} 4, & \text{for } x < -1, \\ x^2, & \text{for } x \geq -1 \end{cases}$
- B) $f(x) = \begin{cases} 4, & \text{for } x < -1, \\ x^3, & \text{for } x \geq -1 \end{cases}$
- C) $f(x) = \begin{cases} 4, & \text{for } x < -1, \\ x^2 - 1, & \text{for } x \geq -1 \end{cases}$
- D) $f(x) = \begin{cases} 4, & \text{for } x < -1, \\ x^3 - 1, & \text{for } x \geq -1 \end{cases}$

Answer: B

68)

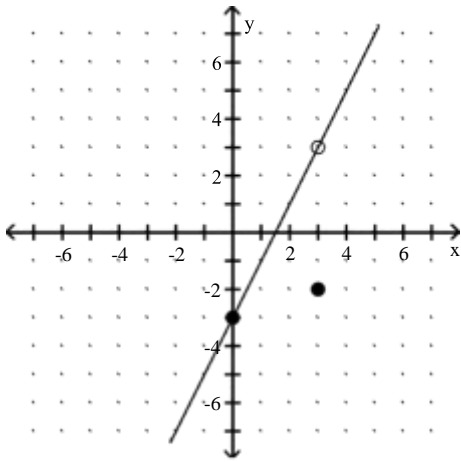

- A) $f(x) = \begin{cases} 2x - 3, & \text{for } x < 3, \\ 2x + 3, & \text{for } x \geq 3 \end{cases}$
- B) $f(x) = \begin{cases} x - 3, & \text{for } x \neq 3, \\ -2, & \text{for } x = 3 \end{cases}$
- C) $f(x) = \begin{cases} 2x - 3, & \text{for } x \neq 3, \\ -2, & \text{for } x = 3 \end{cases}$
- D) $f(x) = \begin{cases} 2x - 3, & \text{for } x \neq 3, \\ -3, & \text{for } x = 3 \end{cases}$

Answer: C

69)

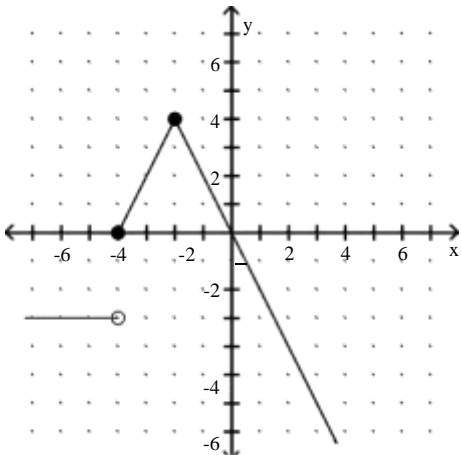

- A) $f(x) = \begin{cases} -3, & \text{for } x \leq -4, \\ -2|x + 2| + 4, & \text{for } x > -4 \end{cases}$
- B) $f(x) = \begin{cases} -3x, & \text{for } x < -4, \\ -2|x + 2| + 4, & \text{for } x \geq -4 \end{cases}$
- C) $f(x) = \begin{cases} -3, & \text{for } x < -4, \\ -2|x + 2| + 4, & \text{for } x \geq -4 \end{cases}$
- D) $f(x) = \begin{cases} -3x, & \text{for } x \leq -4, \\ -2|x + 2| + 4, & \text{for } x > -4 \end{cases}$

Answer: C

70)

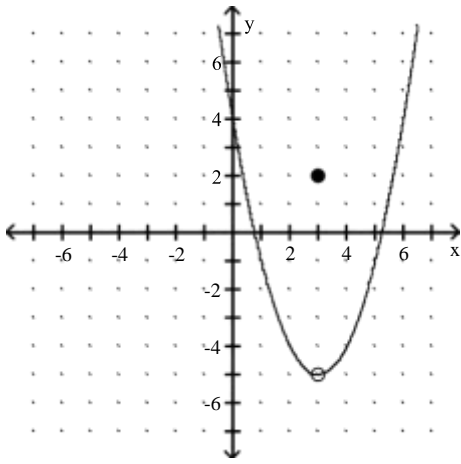

A) $f(x) = (x - 3)^2 - 5$

B) $f(x) = \begin{cases} (x + 3)^2 - 5, & \text{for } x \neq 3, \\ 2, & \text{for } x = 3 \end{cases}$

C) $f(x) = \begin{cases} |x - 3| - 5, & \text{for } x \neq 3, \\ 2, & \text{for } x = 3 \end{cases}$

D) $f(x) = \begin{cases} (x - 3)^2 - 5, & \text{for } x \neq 3, \\ 2, & \text{for } x = 3 \end{cases}$

Answer: D

71)

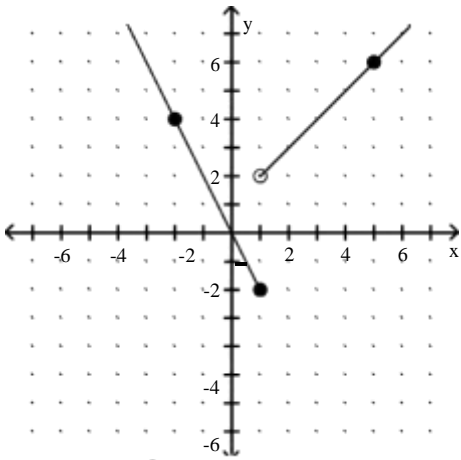

A) $f(x) = \begin{cases} -x, & \text{for } x \leq 1, \\ 2x + 1, & \text{for } x > 1 \end{cases}$

B) $f(x) = \begin{cases} -2x, & \text{for } x \leq 1, \\ x + 2, & \text{for } x > 1 \end{cases}$

C) $f(x) = \begin{cases} x + 1, & \text{for } x \leq 1, \\ x + 1, & \text{for } x > 1 \end{cases}$

D) $f(x) = \begin{cases} -2x, & \text{for } x \leq 1, \\ x + 1, & \text{for } x > 1 \end{cases}$

Answer: D

For the pair of functions, find the indicated sum, difference, product, or quotient.

72) $f(x) = x - 2$, $g(x) = x - 4$

Find $(f + g)(1)$.

A) 4

B) 0

C) -4

D) 8

Answer: C

73) $f(x) = x^2 - 9$, $g(x) = 4x + 8$

Find $(f + g)(4)$.

A) 31

B) 79

C) 19

D) 15

Answer: A

74) $f(x) = 3x^2 - 4$, $g(x) = x - 3$

Find $(f - g)(5)$.

A) 79

B) 69

C) 63

D) -76

Answer: B

75) $f(x) = x + 5$, $g(x) = -4x^2 + 17x - 6$

Find $(fg)(4)$.

A) -18

B) 2

C) 702

D) 70

Answer: A

76) $f(x) = 3x - 3$, $g(x) = 4x^2 + 14x + 4$

Find $(f/g)(-3)$.

A) $\frac{2}{3}$

B) 6

C) -2

D) $-\frac{3}{2}$

Answer: B

77) $f(x) = x^2 - 1$, $g(x) = 2x + 1$

Find $(f/g)\left(-\frac{1}{2}\right)$

A) 0

B) $-\frac{2}{3}$

C) $\frac{1}{2}$

D) does not exist

Answer: D

78) $f(x) = x^2 - 1$, $g(x) = 2x + 1$

Find $(f/g)(\sqrt{3})$.

A) $\frac{4 - \sqrt{3}}{13}$

B) $\frac{\sqrt{3} - 1}{2}$

C) $\frac{3\sqrt{3} + 2}{5}$

D) $\frac{4\sqrt{3} - 2}{11}$

Answer: D

79) $h(x) = x - 1$, $g(x) = \sqrt{x - 2}$

Find $(h + g)(11)$.

A) 9

B) 14

C) 19

D) 13

Answer: D

80) $f(x) = x + 2$, $g(x) = \sqrt{x - 7}$

Find $(f - g)(-2)$.

A) $\sqrt{7}$

B) $\sqrt{9}$

C) does not exist

D) 0

Answer: C

81) $h(x) = x - 2$, $g(x) = \sqrt{x + 6}$

Find $(hg)(-3)$.

A) $-\sqrt{3}$

B) does not exist

C) $-5 - \sqrt{3}$

D) $-5\sqrt{3}$

Answer: D

82) $f(x) = 5x - 9$, $g(x) = 7x - 51$

Find $(f \cdot g)(x)$.

- A) $-2x - 5$
- B) $2x + 5$
- C) $12x - 13$
- D) $-2x - 13$

Answer: A

83) $f(x) = 8x^2 - 7x$, $g(x) = x^2 - 4x - 21$

Find $(f/g)(x)$.

- A) $\frac{8x^2 - 7x}{x^2 - 4x - 21}$
- B) $\frac{8 - x}{21}$
- C) $\frac{8x - 7}{-4}$
- D) $\frac{8x}{x + 1}$

Answer: A

84) $f(x) = 8 - 9x$, $g(x) = -5x + 9$

Find $(f + g)(x)$.

- A) $-4x + 17$
- B) $-14x + 17$
- C) $3x$
- D) $-5x + 8$

Answer: B

85) $f(x) = \sqrt{3x + 3}$, $g(x) = \sqrt{16x - 9}$

Find $(fg)(x)$.

- A) $(\sqrt{3x + 3})(\sqrt{16x - 9})$
- B) $(3x + 3)(4x - 3)$
- C) $(4x - 3)(\sqrt{3x + 3})$
- D) $(3x + 3)(16x - 9)$

Answer: A

86) $f(x) = 8x + 6$, $g(x) = 6x + 9$

Find $(fg)(x)$.

- A) $14x^2 + 108x + 15$
- B) $48x^2 + 54$
- C) $48x^2 + 108x + 54$
- D) $48x^2 + 45x + 54$

Answer: C

87) $f(x) = 9x - 4$, $g(x) = 6x - 52$

Find $(f/g)(x)$.

A) $\frac{6x + 5}{9x + 4}$

B) $\frac{9x + 4}{6x + 5}$

C) $\frac{9x - 4}{6x - 5}$

D) $\frac{6x - 5}{9x - 4}$

Answer: C

88) $f(x) = 8 + x$, $g(x) = 5|x|$

Find $(g/f)(x)$.

A) $\frac{5|x|}{8} + x$

B) $5|x| - 8 + x$

C) $\frac{8 + x}{5|x|}$

D) $\frac{5|x|}{8 + x}$

Answer: D

89) $f(x) = 16 - x^2$; $g(x) = 4 - x$

Find $(f + g)(x)$.

A) $4 + x$

B) $-x^2 - x + 20$

C) $-x^2 + x + 12$

D) $x^3 - 4x^2 - 16x + 64$

Answer: B

90) $f(x) = \frac{4}{x - 6}$, $g(x) = \frac{1}{7 + x}$

Find $(fg)(x)$.

A) $\frac{16}{(x - 6)(7 + x)}$

B) $\frac{16}{x - 6^2}$

C) $\frac{16}{(x - 6)^2}$

D) $\frac{4}{(x - 6)^2}$

Answer: C

91) $f(x) = \frac{5}{x-9}$, $g(x) = \frac{1}{2+x}$

Find $(f/g)(x)$.

A) $\frac{5}{(x-9)(2+x)}$

B) $\frac{5(2+x)}{2+x}$

C) $\frac{5(x-9)}{2+x}$

D) $\frac{5(2+x)}{x-9}$

Answer: D

For the pair of functions, find the indicated domain.

92) $f(x) = 2x - 5$, $g(x) = \sqrt{x+4}$

Find the domain of $f + g$.

A) $(-4, 4)$

B) $[0, \infty)$

C) $[-4, \infty)$

D) $[4, \infty)$

Answer: C

93) $f(x) = 2x - 5$, $g(x) = \sqrt{x+4}$

Find the domain of f/g .

A) $(-4, 4)$

B) $[0, \infty)$

C) $(-4, \infty)$

D) $[4, \infty)$

Answer: C

94) $f(x) = x^2 - 36$, $g(x) = 2x + 3$

Find the domain of $f - g$.

A) $(-\infty, \infty)$

B) $(-6, 6)$

C) $[6, \infty)$

D) $[0, \infty)$

Answer: A

95) $f(x) = x^2 - 9$, $g(x) = 2x + 3$

Find the domain of f/g .

A) $\left(-\infty, -\frac{3}{2}\right) \cup \left(\frac{3}{2}, \infty\right)$

B) $\left[\frac{3}{2}, \infty\right)$

C) $(-\infty, \infty)$

D) $(-3, 3)$

Answer: A

96) $f(x) = x^2 - 49$, $g(x) = 2x + 3$

Find the domain of g/f .

A) $\left(-\infty, -\frac{3}{2}\right) \cup \left(\frac{3}{2}, \infty\right)$

B) $(-\infty, -7) \cup (-7, 7) \cup (7, \infty)$

C) $(-\infty, \infty)$

D) $\left(-\frac{3}{2}, \infty\right)$

Answer: B

97) For $f(x) = \sqrt{x-2}$ and $g(x) = \frac{1}{x-5}$

Find the domain of fg .

A) $(2, 5) \cup (5, \infty)$

B) $[0, 5) \cup (5, \infty)$

C) $[2, \infty)$

D) $[2, 5) \cup (5, \infty)$

Answer: D

98) $f(x) = \sqrt{6-x}$; $g(x) = \sqrt{x-1}$

Find the domain of fg .

A) $(1, 6)$

B) $[1, 6]$

C) $(-\infty, 1) \cup (6, \infty)$

D) $(-\infty, 6) \cup (6, \infty)$

Answer: B

99) $f(x) = 5x + 9$, $g(x) = \frac{5}{x+4}$

Find the domain of $f + g$.

A) $(-\infty, -4)$ or $(-4, \infty)$

B) $(0, \infty)$

C) $(-\infty, \infty)$

D) $(-\infty, -5)$ or $(-5, \infty)$

Answer: A

100) $f(x) = \frac{2x}{x-1}$, $g(x) = \frac{4}{x+10}$

Find the domain of $f + g$.

A) $(-\infty, -10) \cup (-10, 1) \cup (1, \infty)$

B) $(-\infty, -1) \cup (-1, 10) \cup (10, \infty)$

C) $(-\infty, \infty)$

D) $(-\infty, -4) \cup (-4, -2) \cup (-2, \infty)$

Answer: A

101) $f(x) = 3x^2 - 7$, $g(x) = 2x^3 + 8$

Find the domain of $f + g$.

- A) $(-\infty, -3) \cup (-3, -2) \cup (-2, \infty)$
- B) $(-\infty, 0) \cup (0, \infty)$
- C) $(0, \infty)$
- D) $(-\infty, \infty)$

Answer: D

Consider the functions F and G as shown in the graph. Provide an appropriate response.

102) Find the domain of $F + G$.

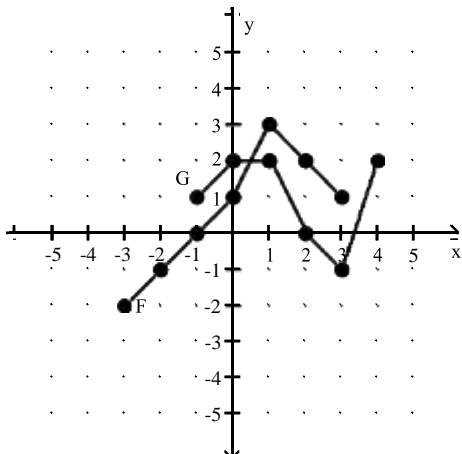

- A) $[-1, 4]$
- B) $[-3, 4]$
- C) $[-3, 3]$
- D) $[-1, 3]$

Answer: D

103) Find the domain of $F - G$.

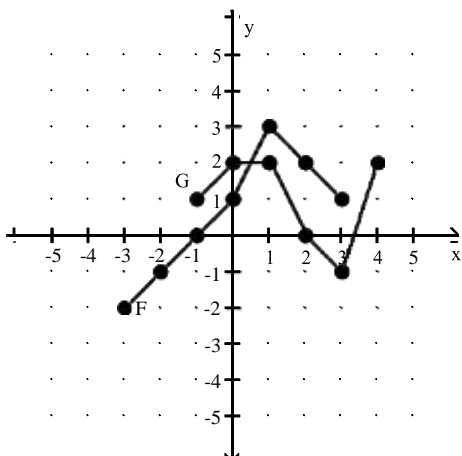

- A) $[-3, 4]$
- B) $[-3, 3]$
- C) $[-1, 3]$
- D) $[-1, 4]$

Answer: C

104) Find the domain of FG .

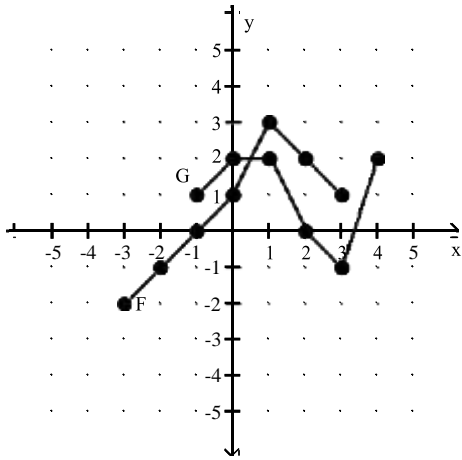

- A) $[-3, 4]$
- B) $[-1, 3]$
- C) $[-3, 3]$
- D) $[-1, 4]$

Answer: B

105) Find the domain of F/G .

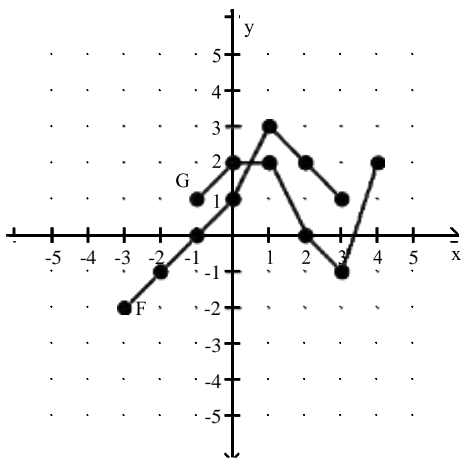

- A) $[-1, 3]$
- B) $[-1, 2) \cup (2, 3]$
- C) $[-3, -1) \cup (-1, 4)$
- D) $[-3, 4]$

Answer: B

106) Find the domain of G/F .

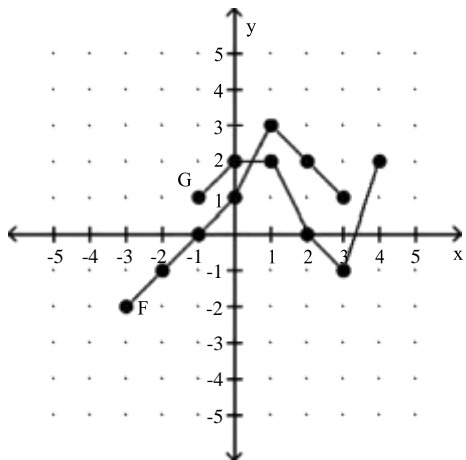

- A) $(-1, 3]$
- B) $[-3, 3]$
- C) $[-1, 2) \cup (2, 3)$
- D) $[-3, 4]$

Answer: A

107) Graph $F + G$.

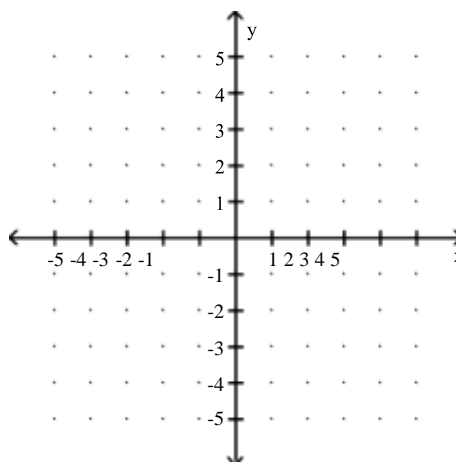
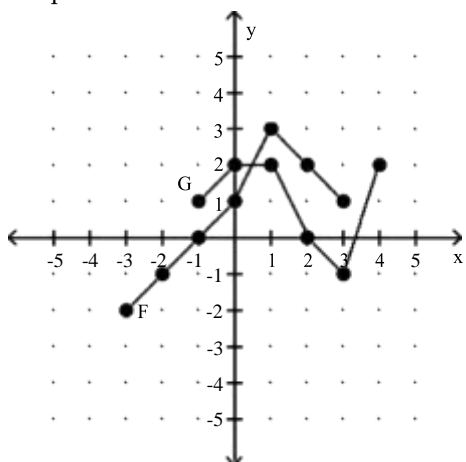

A)

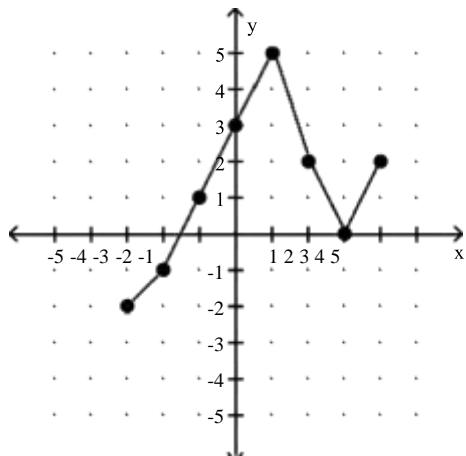

B)

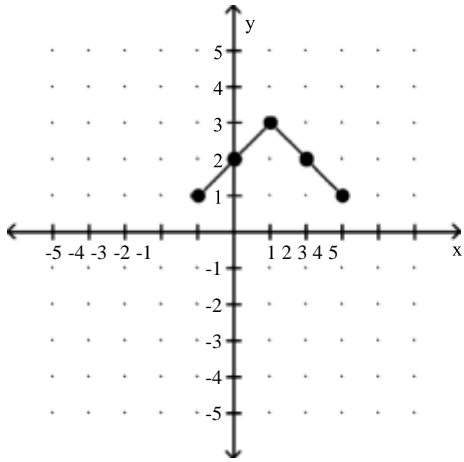

C)

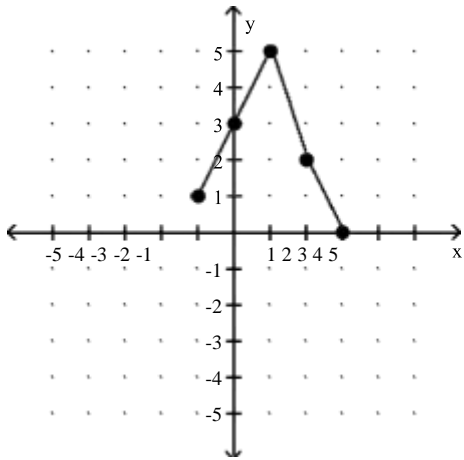

D)

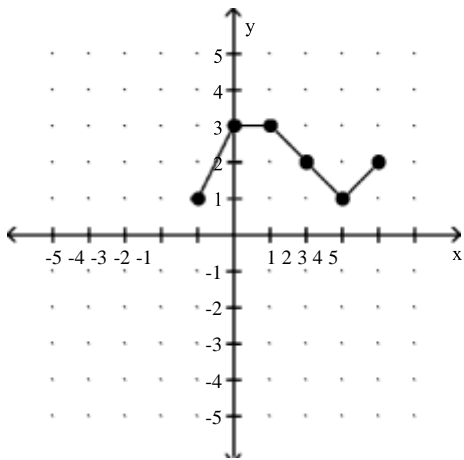

Answer: C

108) Graph F - G.

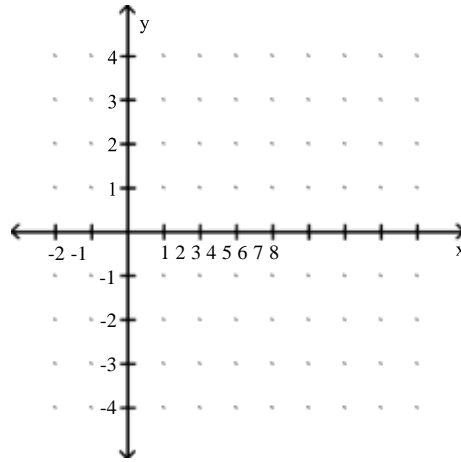
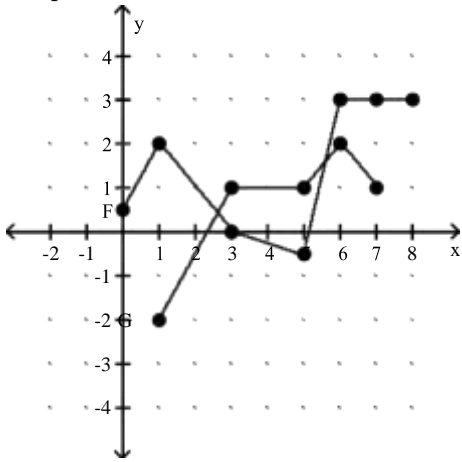

A)

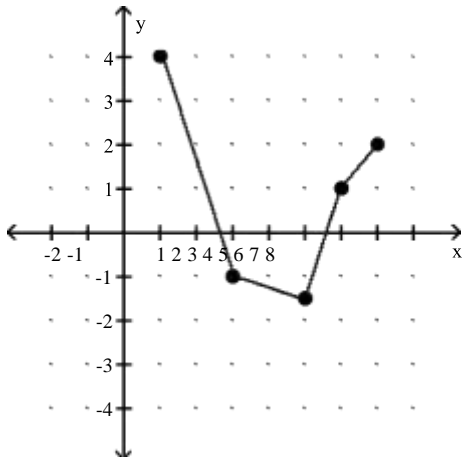

B)

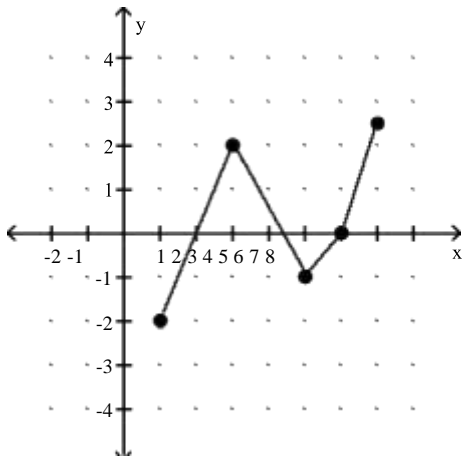

C)

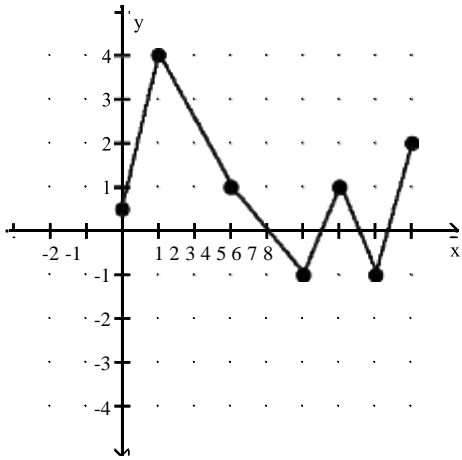

D)

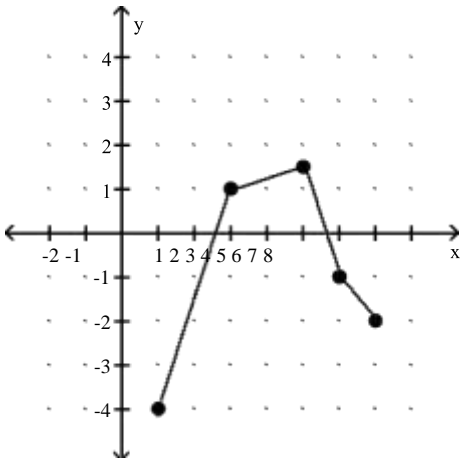

Answer: A

109) Graph G - F.

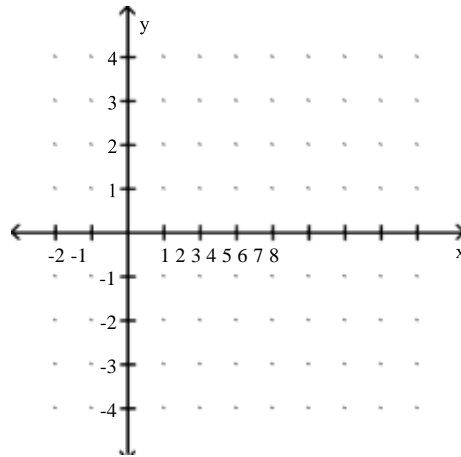
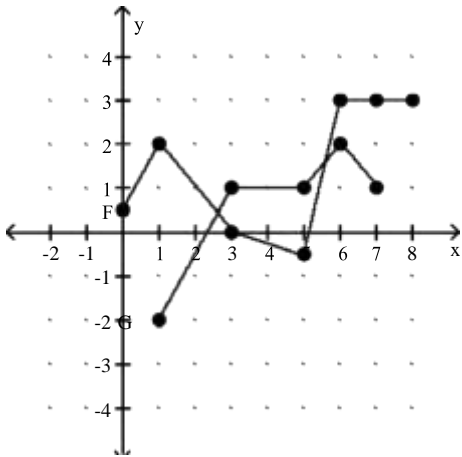

A)

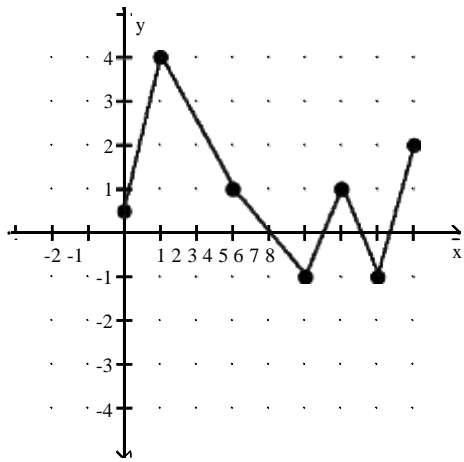

B)

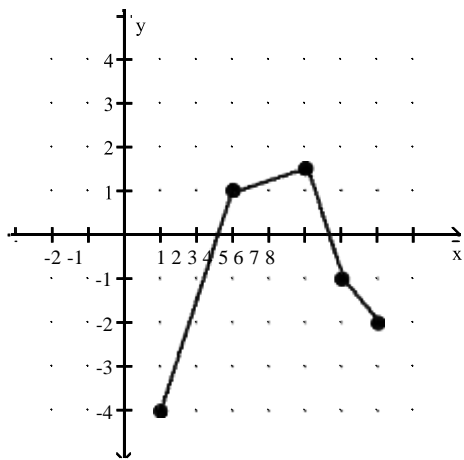

C)

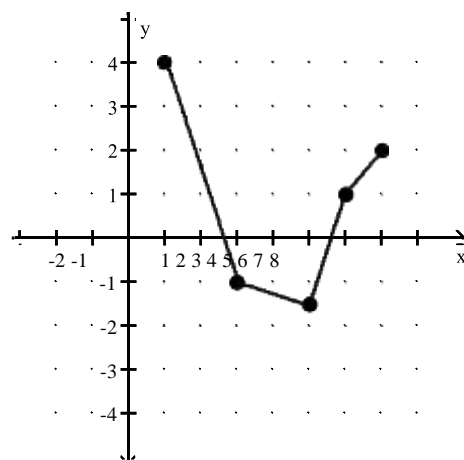

D)

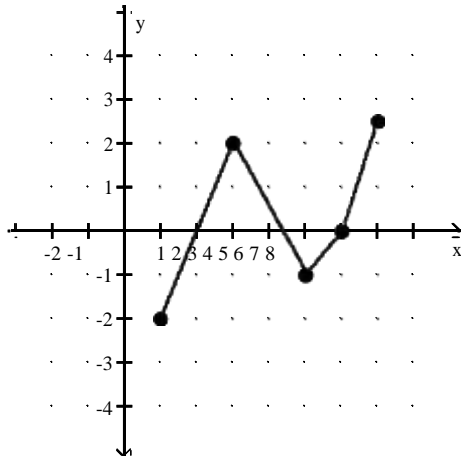

Answer: B

Solve.

- 110) At Allied Electronics, production has begun on the X-15 Computer Chip. The total revenue function is given by $R(x) = 44x - 0.3x^2$ and the total cost function is given by $C(x) = 7x + 9$, where x represents the number of boxes of computer chips produced. The total profit function, $P(x)$, is such that $P(x) = R(x) - C(x)$. Find $P(x)$.

- A) $P(x) = 0.3x^2 + 37x - 18$
- B) $P(x) = -0.3x^2 + 37x - 9$
- C) $P(x) = -0.3x^2 + 30x + 9$
- D) $P(x) = 0.3x^2 + 30x - 27$

Answer: B

- 111) At Allied Electronics, production has begun on the X-15 Computer Chip. The total revenue function is given by $R(x) = 50x - 0.3x^2$ and the total profit function is given by $P(x) = -0.3x^2 + 48x - 11$, where x represents the number of boxes of computer chips produced. The total cost function, $C(x)$, is such that $C(x) = R(x) - P(x)$. Find $C(x)$.

- A) $C(x) = 3x + 16$
- B) $C(x) = 4x + 7$
- C) $C(x) = -0.3x^2 + 4x + 11$
- D) $C(x) = 2x + 11$

Answer: D

- 112) At Allied Electronics, production has begun on the X-15 Computer Chip. The total cost function is given by $C(x) = 10x + 13$ and the total profit function is given by $P(x) = -0.3x^2 + 43x - 13$, where x represents the number of boxes of computer chips produced. The total revenue function, $R(x)$, is such that $R(x) = C(x) + P(x)$. Find $R(x)$.

- A) $R(x) = 55x - 0.3x^2$
- B) $R(x) = 53x - 0.3x^2$
- C) $R(x) = 53x + 0.3x^2$
- D) $R(x) = 52x - 0.6x^2$

Answer: B

113) AAA Technology finds that the total revenue function associated with producing a new type of computer chip is $R(x) = 58 - 0.3x^2$, and the total cost function is $C(x) = 8x + 18$, where x represents the number of units of chips produced. Find the total profit function, $P(x)$.

- A) $P(x) = -0.03x^2 + 8x - 40$
- B) $P(x) = -0.03x^2 + 8x + 76$
- C) $P(x) = 0.03x^2 + 8x + 42$
- D) $P(x) = -0.03x^2 - 8x + 40$

Answer: D

114) Acme Communication finds that the total revenue function associated with producing a new type of cellular phone is $R(x) = 207x - x^2$, and the total cost function is $C(x) = 8000 + 8x$, where x represents the number of units of cellular phones produced. Find the total profit function, $P(x)$.

- A) $P(x) = -x^2 + 215x + 8000$
- B) $P(x) = -x^2 + 199x - 8000$
- C) $P(x) = -2x^2 + 221x - 9000$
- D) $P(x) = x^4 - 199x^2 + 8000$

Answer: B

For the function f , construct and simplify the difference quotient $\frac{f(x+h) - f(x)}{h}$.

115) $f(x) = 9x + 5$

- A) 0
- B) 9
- C) $9 + \frac{18(x+5)}{h}$
- D) $9 + \frac{10}{h}$

Answer: B

116) $f(x) = \frac{1}{2x}$

- A) 0
- B) $\frac{-1}{x(x+h)}$
- C) $\frac{-1}{2x(x+h)}$
- D) $\frac{1}{2x}$

Answer: C

$$117) f(x) = \frac{12}{x + 23}$$

$$A) -\frac{276}{(x + h + 23)(x + 23)}$$

$$B) \frac{12}{(x + h + 23)(x + 23)}$$

$$C) -\frac{12}{(x + h + 23)(x + 23)}$$

$$D) -\frac{12}{(x + 12)^2}$$

Answer: C

$$118) f(x) = \frac{x}{2 - x}$$

$$A) \frac{x}{(2 - x + h)(2 - x)}$$

$$B) \frac{hx}{(2 - x - h)(2 + x)}$$

$$C) \frac{2}{(2 - x - h)(2 - x)}$$

$$D) -\frac{2}{(2 - x + h)(2 - x)}$$

Answer: C

$$119) f(x) = \frac{x - 6}{x + 3}$$

$$A) \frac{9(x + h + 3)}{(x + 3)}$$

$$B) \frac{9}{(x + h + 3)(x + 3)}$$

$$C) \frac{10}{(x + 3)(x - 3)}$$

$$D) -\frac{9}{x(x + 3)}$$

Answer: B

$$120) f(x) = 6 - 10x^3$$

$$A) -10(x^2 - xh - h^2)$$

$$B) -18x^2$$

$$C) -10(3x^2 + 3xh + h^2)$$

$$D) -10(3x^2 - 3x - h)$$

Answer: C

121) $f(x) = 8x^2 + 8x$

- A) $16x^2 + 8h + 8x$
- B) $16x + 8h + 8$
- C) $24x - 10h + 16$
- D) $16x + 8$

Answer: B

122) $f(x) = 4|x| + 9x$

- A) $\frac{4|x + h| - 9h - 4|x|}{h}$
- B) $-8h$
- C) $-10h$
- D) $\frac{-4|x + h| - 10h + 4|x|}{h}$

Answer: A

Find the requested function value.

123) $f(x) = \frac{x - 8}{8}$, $g(x) = 2x + 6$

Find $(g \circ f)(-24)$.

- A) -2
- B) 168
- C) -32
- D) $-\frac{25}{4}$

Answer: A

124) $f(x) = -9x + 7$, $g(x) = -9x^2 - 2x + 6$

Find $(f \circ g)(-4)$.

- A) -467
- B) $-16,721$
- C) -443
- D) 1177

Answer: D

125) $f(x) = -7x - 2$, $g(x) = -5x^2 - 9x + 1$

Find $(g \circ f)(5)$.

- A) 519
- B) -6511
- C) 1181
- D) 481

Answer: B

$$126) f(x) = \frac{x-5}{2}, g(x) = 4x + 8$$

Find $(g \circ f)(-1)$.

- A) -12
- B) -4
- C) -36
- D) $-\frac{1}{2}$

Answer: B

For the pair of functions, find the indicated composition.

$$127) f(x) = 3x + 14, g(x) = 3x - 1$$

Find $(f \circ g)(x)$.

- A) $9x + 17$
- B) $9x + 11$
- C) $9x + 41$
- D) $9x + 13$

Answer: B

$$128) f(x) = -3x + 4, g(x) = 5x + 3$$

Find $(g \circ f)(x)$.

- A) $-15x + 23$
- B) $15x + 23$
- C) $-15x + 13$
- D) $-15x - 17$

Answer: A

$$129) f(x) = \frac{5}{x-8}, g(x) = \frac{5}{2x}$$

Find $(f \circ g)(x)$.

- A) $\frac{10x}{5 + 16x}$
- B) $\frac{5x - 40}{10x}$
- C) $\frac{5x}{5 - 16x}$
- D) $\frac{10x}{5 - 16x}$

Answer: D

$$130) f(x) = \frac{x-9}{5}, g(x) = 5x + 9$$

Find $(g \circ f)(x)$.

- A) x
- B) $5x + 36$
- C) $x - \frac{9}{5}$
- D) $x + 18$

Answer: A

131) $f(x) = \sqrt{x + 5}$, $g(x) = 8x - 9$

Find $(f \circ g)(x)$.

- A) $2\sqrt{x + 1}$
- B) $8\sqrt{x + 5} - 9$
- C) $2\sqrt{x - 1}$
- D) $8\sqrt{x - 4}$

Answer: C

132) $f(x) = 4x^2 + 4x + 7$, $g(x) = 4x - 4$

Find $(g \circ f)(x)$.

- A) $16x^2 + 16x + 32$
- B) $4x^2 + 16x + 24$
- C) $16x^2 + 16x + 24$
- D) $4x^2 + 4x + 3$

Answer: C

133) $f(x) = \frac{7}{x}$, $g(x) = 3x^3$

Find $(g \circ f)(x)$.

- A) $\frac{7}{3x^3}$
- B) $\frac{3x^3}{343}$
- C) $\frac{7}{3x^3}$
- D) $\frac{1029}{x^3}$

Answer: D

134) $f(x) = \frac{7}{2}x$, $g(x) = -\frac{2}{7}x$

Find $(f \circ g)(x)$.

- A) 0
- B) x
- C) 1
- D) -x

Answer: D

135) $f(x) = x^6 + 2$, $g(x) = \sqrt[6]{x - 2}$

Find $(g \circ f)(x)$.

- A) |x|
- B) -x
- C) x^6
- D) x

Answer: D

136) $f(x) = x^3 + 4x^2 - 8x - 3$, $g(x) = x - 1$

Find $(f \circ g)(x)$.

A) $x^3 + 4x^2 - 8x - 2$

B) $x^3 + 4x^2 - 8x - 4$

C) $x^3 + 1x^2 - 13x + 8$

D) $x^3 + 7x^2 + 3x - 6$

Answer: C

For the pair of functions, find the indicated domain.

137) $f(x) = 5x + 45$, $g(x) = x + 2$

Find the domain of $f \circ g$.

A) $(-\infty, -11) \cup (-11, \infty)$

B) $(-\infty, \infty)$

C) $(-\infty, -11] \cup [-11, \infty)$

D) $(-\infty, 11) \cup (11, \infty)$

Answer: B

138) $f(x) = \frac{2}{x+4}$, $g(x) = x + 1$

Find the domain of $f \circ g$.

A) $(-\infty, \infty)$

B) $(-\infty, -5) \cup (-5, \infty)$

C) $(-\infty, -5] \cup [-5, \infty)$

D) $(-\infty, -4) \cup (-4, \infty)$

Answer: B

139) $f(x) = \frac{5}{x+7}$, $g(x) = x + 5$

Find the domain of $g \circ f$.

A) $(-\infty, -7) \cup (-7, \infty)$

B) $(-\infty, -7] \cup [-7, \infty)$

C) $(-\infty, \infty)$

D) $(-\infty, -12) \cup (-12, \infty)$

Answer: A

140) $f(x) = 2x - 5$, $g(x) = \sqrt{x+6}$

Find the domain of $f \circ g$.

A) $[-6, \infty)$

B) $[6, \infty)$

C) $(-6, 6)$

D) $[0, \infty)$

Answer: A

141) $f(x) = 2x - 5$, $g(x) = \sqrt{x + 6}$

Find the domain of $g \circ f$.

- A) $(-6, 6)$
- B) $[6, \infty)$
- C) $[-0.5, \infty)$
- D) $[-\infty, -0.5)$

Answer: C

142) $f(x) = x^2 - 25$, $g(x) = 2x + 3$

Find the domain of $f \circ g$.

- A) $(-5, 5)$
- B) $[0, \infty)$
- C) $(-\infty, \infty)$
- D) $[5, \infty)$

Answer: C

143) $f(x) = x^2 - 81$, $g(x) = 2x + 3$

Find the domain of $g \circ f$.

- A) $\left[\frac{3}{2}, \infty \right)$
- B) $\left(-\infty, -\frac{3}{2} \right) \cup \left(\frac{3}{2}, \infty \right)$
- C) $(-9, 9)$
- D) $(-\infty, \infty)$

Answer: D

144) $f(x) = \sqrt{x}$, $g(x) = 4x + 16$

Find the domain of $f \circ g$.

- A) $(-\infty, -4] \cup [0, \infty)$
- B) $(-\infty, \infty)$
- C) $[0, \infty)$
- D) $[-4, \infty)$

Answer: D

145) $f(x) = x^2 - 49$, $g(x) = 2x + 3$

Find the domain of $g \circ f$.

- A) $(-7, 7)$
- B) $(-\infty, \infty)$
- C) $[7, \infty)$
- D) $\left(-\infty, -\frac{3}{2} \right) \cup \left(\frac{3}{2}, \infty \right)$

Answer: B

Find $f(x)$ and $g(x)$ such that $h(x) = (f \circ g)(x)$.

$$146) h(x) = \frac{1}{x^2 - 2}$$

$$A) f(x) = \frac{1}{x^2}, g(x) = \frac{1}{2}$$

$$B) f(x) = \frac{1}{2}, g(x) = x^2 - 2$$

$$C) f(x) = \frac{1}{x^2}, g(x) = x - 2$$

$$D) f(x) = \frac{1}{x}, g(x) = x^2 - 2$$

Answer: D

$$147) h(x) = |10x + 4|$$

$$A) f(x) = x, g(x) = 10x + 4$$

$$B) f(x) = |-x|, g(x) = 10x - 4$$

$$C) f(x) = |x|, g(x) = 10x + 4$$

$$D) f(x) = -|x|, g(x) = 10x + 4$$

Answer: C

$$148) h(x) = \frac{2}{x^2} + 6$$

$$A) f(x) = \frac{1}{x}, g(x) = \frac{2}{x} + 6$$

$$B) f(x) = x, g(x) = \frac{2}{x} + 6$$

$$C) f(x) = \frac{2}{x^2}, g(x) = 6$$

$$D) f(x) = x + 6, g(x) = \frac{2}{x^2}$$

Answer: D

$$149) h(x) = \frac{10}{\sqrt{3x + 7}}$$

$$A) f(x) = \frac{10}{\sqrt{x}}, g(x) = 3x + 7$$

$$B) f(x) = \sqrt{3x + 7}, g(x) = 10$$

$$C) f(x) = 10, g(x) = \sqrt{3x + 7}$$

$$D) f(x) = \frac{10}{x}, g(x) = 3x + 7$$

Answer: A

150) $h(x) = (9x - 14)^9$

A) $f(x) = 9x^9, g(x) = x - 14$

B) $f(x) = x^9, g(x) = 9x - 14$

C) $f(x) = (9x)^9, g(x) = -14$

D) $f(x) = 9x - 14, g(x) = x^9$

Answer: B

151) $h(x) = \sqrt{-28x^2 + 82}$

A) $f(x) = \sqrt{x}, g(x) = -28x^2 + 82$

B) $f(x) = \sqrt{-28x + 82}, g(x) = x^2$

C) $f(x) = \sqrt{-28x^2}, g(x) = \sqrt{82}$

D) $f(x) = -28x^2 + 82, g(x) = \sqrt{x}$

Answer: A

152) $h(x) = \sqrt{4 - \sqrt{x - 4}}$

A) $f(x) = \sqrt{x - 4}, g(x) = \sqrt{4 - x}$

B) $f(x) = \sqrt{4 + x}, g(x) = \sqrt{x - 4}$

C) $f(x) = \sqrt{x - 4}, g(x) = \sqrt{x - 4}$

D) $f(x) = \sqrt{4 - x}, g(x) = \sqrt{x - 4}$

Answer: D

153) $h(x) = (x - 2)^5 + 8(x - 2)^4 - 2(x - 2)^2 + 1$

A) $f(x) = x^5 - 8x^4 + 2x^2 + 1, g(x) = x + 2$

B) $f(x) = x^5 + 8x^4 - 2x^2 + 1, g(x) = x - 2$

C) $f(x) = x^5 + x^4 - x^2 + 1, g(x) = x - 2$

D) $f(x) = x^5 + 8x^4 - 2x^2, g(x) = x - 3$

Answer: B

154) $h(x) = \left(\frac{x^2 + 3}{3 - x^2} \right)^4$

A) $f(x) = x^4, g(x) = \frac{x^2 + 3}{3 - x^2}$

B) $f(x) = \frac{x^2 + 3}{3 - x^2}, g(x) = x^4$

C) $f(x) = \frac{1}{x^4}, g(x) = \frac{x^2 + 3}{3 - x^2}$

D) $f(x) = (x^2 + 3)^4, g(x) = 3 - x^2$

Answer: A

$$155) h(x) = \sqrt{\frac{x-5}{x+2}}$$

$$A) f(x) = \sqrt{x}, g(x) = \frac{x-5}{x+2}$$

$$B) f(x) = \sqrt{\frac{1}{x+2}}, g(x) = x-5x$$

$$C) f(x) = \frac{x-5}{x+2}, g(x) = \sqrt{x}$$

$$D) f(x) = \sqrt{x-5}, g(x) = \frac{1}{x+2}$$

Answer: A

Solve the problem.

156) A balloon (in the shape of a sphere) is being inflated. The radius is increasing at a rate of 11 cm per second. Find a function, $r(t)$, for the radius in terms of t . Find a function, $V(r)$, for the volume of the balloon in terms of r . Find $(V \circ r)(t)$.

$$A) (V \circ r)(t) = \frac{847\pi t^3}{3}$$

$$B) (V \circ r)(t) = \frac{58564\pi t \sqrt{t}}{3}$$

$$C) (V \circ r)(t) = \frac{6655\pi t^2}{3}$$

$$D) (V \circ r)(t) = \frac{5324\pi t^3}{3}$$

Answer: D

157) A stone is thrown into a pond. A circular ripple is spreading over the pond in such a way that the radius is increasing at the rate of 4.3 feet per second. Find a function, $r(t)$, for the radius in terms of t . Find a function, $A(r)$, for the area of the ripple in terms of r . Find $(A \circ r)(t)$.

$$A) (A \circ r)(t) = 18.49\pi t^2$$

$$B) (A \circ r)(t) = 18.49\pi^2 t$$

$$C) (A \circ r)(t) = 4.3\pi t^2$$

$$D) (A \circ r)(t) = 8.6\pi t^2$$

Answer: A

158) Ken is 6 feet tall and is walking away from a streetlight. The streetlight has its light bulb 14 feet above the ground, and Ken is walking at the rate of 1.5 feet per second. Find a function, $d(t)$, which gives the distance Ken is from the streetlight in terms of time. Find a function, $S(d)$, which gives the length of Ken's shadow in terms of d . Then find $(S \circ d)(t)$.

$$A) (S \circ d)(t) = 0.83t$$

$$B) (S \circ d)(t) = 1.43t$$

$$C) (S \circ d)(t) = 2.54t$$

$$D) (S \circ d)(t) = 1.13t$$

Answer: D

Determine if the graph is symmetric with respect to x-axis, y-axis, and/or the origin.

159)

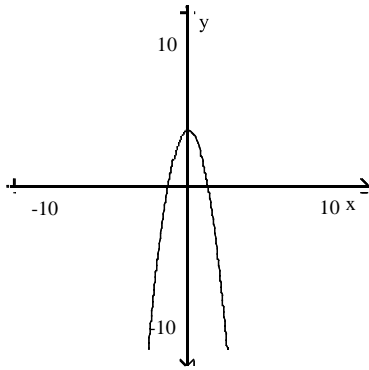

- A) x-axis, origin
- B) y-axis
- C) Origin
- D) x-axis

Answer: B

160)

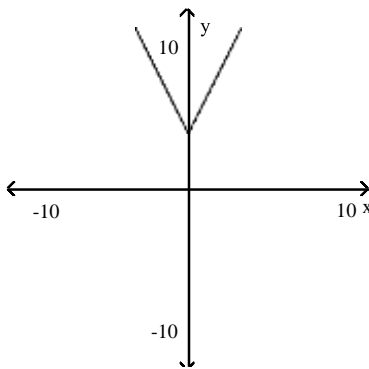

- A) y-axis
- B) Origin
- C) x-axis, origin
- D) x-axis

Answer: A

161)

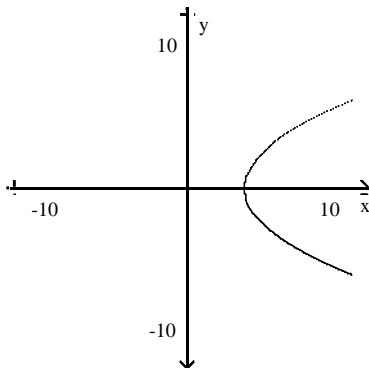

- A) Origin
- B) x-axis, origin
- C) y-axis
- D) x-axis

Answer: D

162)

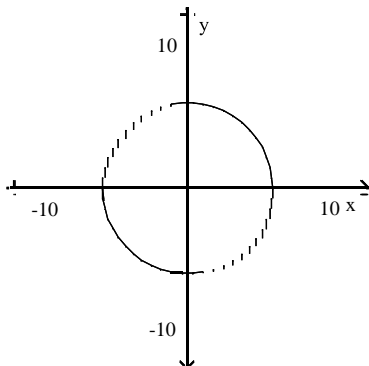

- A) x-axis, origin
- B) x-axis, y-axis, origin
- C) x-axis
- D) Origin

Answer: B

163)

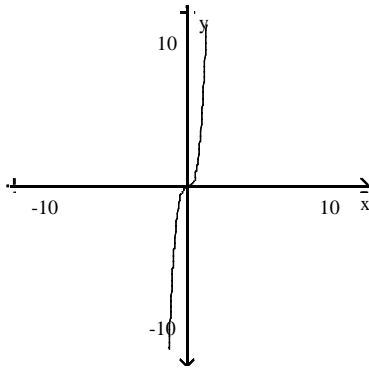

- A) x-axis, origin
- B) x-axis
- C) Origin
- D) y-axis

Answer: C

164)

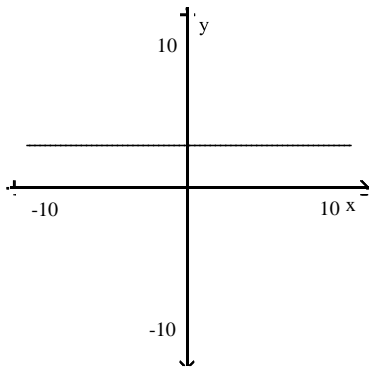

- A) x-axis
- B) y-axis
- C) y-axis, origin
- D) x-axis, y-axis

Answer: B

165)

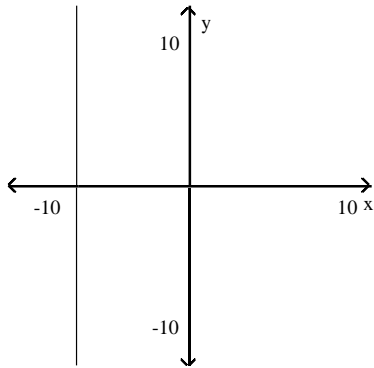

- A) x-axis
- B) no symmetry
- C) y-axis
- D) x-axis, y-axis

Answer: A

166)

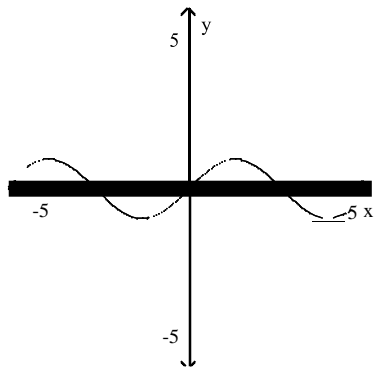

- A) no symmetry
- B) origin
- C) x-axis
- D) y-axis

Answer: B

Determine algebraically whether the graph is symmetric with respect to the x-axis, the y-axis, and the origin.

167) $y = 5x^2 - 5$

- A) x-axis only
- B) y-axis only
- C) Originonly
- D) x-axis, y-axis, origin

Answer: B

168) $x^2 + 4y^4 = 2$

- A) x-axis only
- B) Originonly
- C) y-axis only
- D) x-axis, y-axis, origin

Answer: D

169) $xy = 5$

- A) x-axis, y-axis, origin
- B) Originonly
- C) x-axis only
- D) y-axis only

Answer: B

170) $3x = 2y^2 - 3$

- A) x-axis, y-axis, origin
- B) y-axis only
- C) x-axis only
- D) Origin only

Answer: C

171) $x^2 + y^2 = 8$

- A) x-axis only
- B) Originonly
- C) x-axis, y-axis, origin
- D) y-axis only

Answer: C

172) $x^2 + xy^2 = 1$

- A) Origin only
- B) x-axis only
- C) y-axis only
- D) x-axis, y-axis, origin

Answer: B

173) $y = (x + 9)(x - 9)$

- A) x-axis only
- B) Origin only
- C) x-axis, y-axis, origin
- D) y-axis only

Answer: D

174) $x^4 + y^4 = 6$

- A) x-axis, y-axis, origin
- B) y-axis only
- C) Originonly
- D) x-axis only

Answer: A

175) $y = |2x|$

- A) x-axis, y-axis, origin
- B) Originonly
- C) y-axis only
- D) x-axis only

Answer: C

176) $20x = |y|$

- A) Origin only
- B) x-axis, y-axis, origin
- C) y-axis only
- D) x-axis only

Answer: D

Find the point that is symmetric to the given point with respect to the requested axis.

177) Symmetric with respect to the y-axis

(1.5, -1.75)

- A) (-1.5, 1.75)
- B) (1.5, -1.5)
- C) (-1.75, 1.5)
- D) (-1.5, -1.75)

Answer: D

178) Symmetric with respect to the y-axis

(1.5, 1.75)

- A) (-1.5, -1.75)
- B) (1.5, -1.5)
- C) (1.75, 1.5)
- D) (-1.5, 1.75)

Answer: D

179) Symmetric with respect to the x-axis

(7, 2)

- A) (-7, -2)
- B) (7, -2)
- C) (-7, 2)
- D) (2, 7)

Answer: B

180) Symmetric with respect to the origin

$\left(3, \frac{27}{2}\right)$

- A) $\left(3, -\frac{27}{2}\right)$
- B) $\left(-\frac{27}{2}, 3\right)$
- C) $\left(3, -\frac{27}{2}\right)$
- D) $\left(-3, -\frac{27}{2}\right)$

Answer: D

181) Symmetric with respect to the origin

$(-1, 4)$

A) $(4, -1)$

B) $(1, 4)$

C) $(1, -4)$

D) $(-1, -4)$

Answer: C

Determine whether the given function is even, odd, or neither even nor odd.

182)

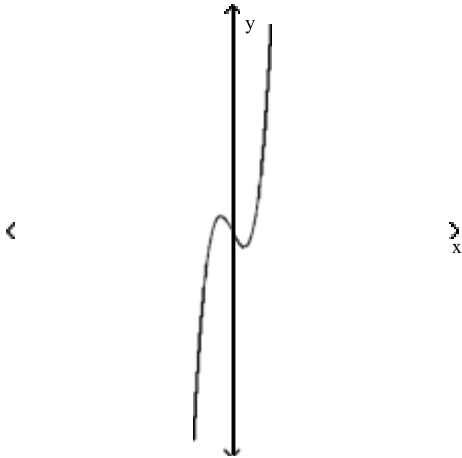

A) Neither

B) Even

C) Odd

Answer: C

183)

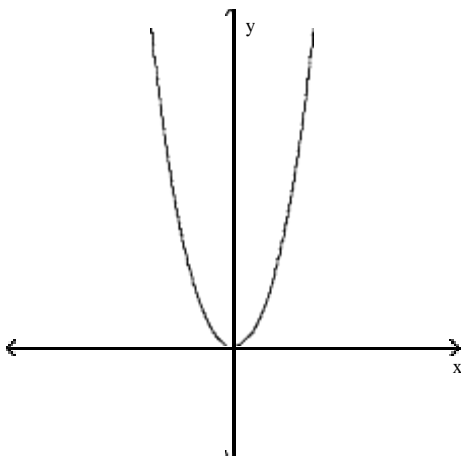

A) Odd

B) Even

C) Neither

Answer: B

184)

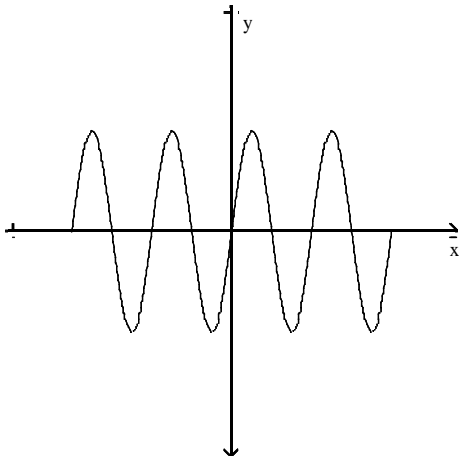

- A) Even
- B) Neither
- C) Odd

Answer: C

185)

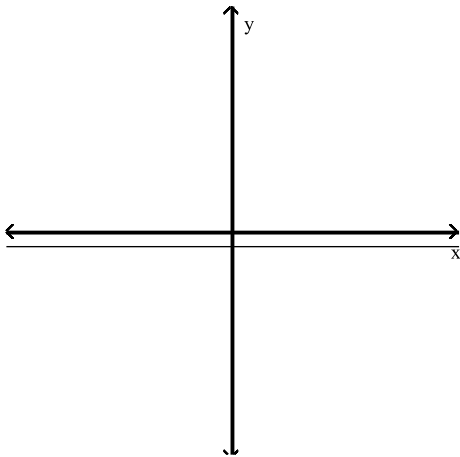

- A) Odd
- B) Even
- C) Neither

Answer: B

186)

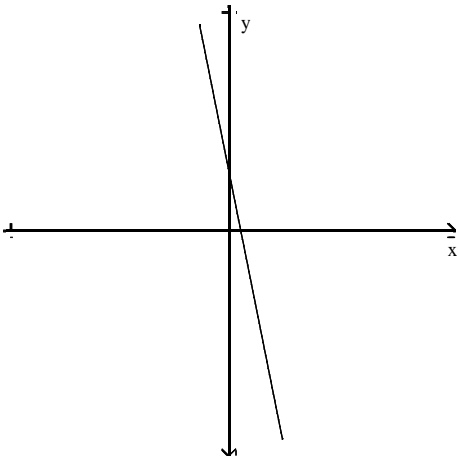

- A) Neither
- B) Odd
- C) Even

Answer: A

187)

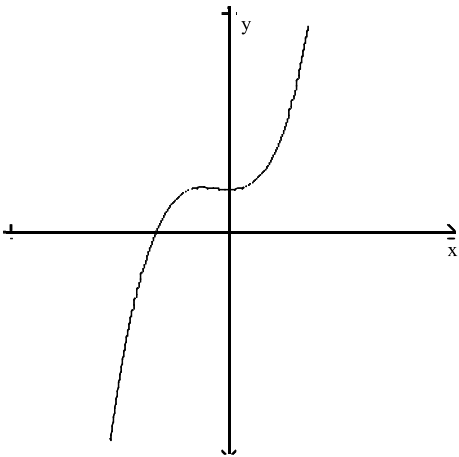

- A) Odd
- B) Even
- C) Neither

Answer: C

188)

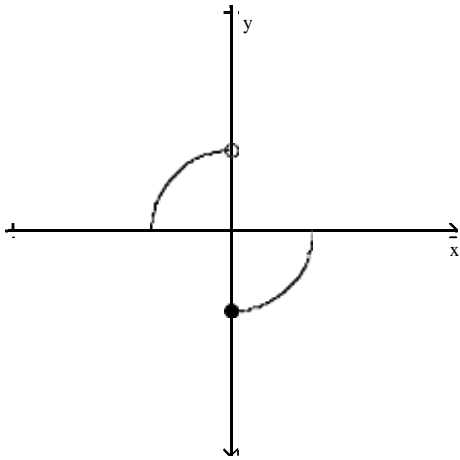

- A) Neither
- B) Odd
- C) Even

Answer: A

Determine algebraically whether the function is even, odd, or neither even nor odd.

189) $f(x) = 4x^2 + 1$

- A) Even
- B) Odd
- C) Neither

Answer: A

190) $f(x) = -7x^5 - 3x^3$

- A) Even
- B) Odd
- C) Neither

Answer: B

191) $f(x) = -0.22x^2 + |x| + 7$

- A) Even
- B) Odd
- C) Neither

Answer: A

192) $f(x) = -8x^4 + 7x - 3$

- A) Even
- B) Odd
- C) Neither

Answer: C

193) $f(x) = x + \frac{3}{x}$

- A) Even
- B) Odd
- C) Neither

Answer: B

194) $f(x) = 5\sqrt[3]{x}$

- A) Even
- B) Odd
- C) Neither

Answer: B

195) $f(x) = \frac{5}{x^2}$

- A) Even
- B) Odd
- C) Neither

Answer: A

196) $f(x) = 4x - 8|x|$

- A) Even
- B) Odd
- C) Neither

Answer: C

197) $f(x) = 4$

- A) Even
- B) Odd
- C) Neither

Answer: A

198) $f(x) = \sqrt{x^2 + 27}$

- A) Even
- B) Odd
- C) Neither

Answer: A

Answer the question.

199) How can the graph of $f(x) = -7|x|$ be obtained from the graph of $y = |x|$?

- A) Stretch it vertically by multiplying each y-coordinate by 7. Reflect it across the x-axis.
- B) Stretch it vertically by multiplying each y-coordinate by -7. Reflect it across the x-axis.
- C) Stretch it vertically by multiplying each y-coordinate by 7. Reflect it across the y-axis.
- D) Stretch it vertically by multiplying each y-coordinate by -7. Reflect it across the y-axis.

Answer: A

200) How can the graph of $f(x) = -\sqrt{x+1}$ be obtained from the graph of $y = \sqrt{x}$?

- A) Shift it horizontally 1 units to the left. Reflect it across the y-axis.
- B) Shift it horizontally 1 units to the right. Reflect it across the x-axis.
- C) Shift it horizontally -1 units to the left. Reflect it across the x-axis.
- D) Shift it horizontally 1 units to the left. Reflect it across the x-axis.

Answer: D

201) How can the graph of $f(x) = -3\sqrt{x} + 3$ be obtained from the graph of $y = \sqrt{x}$?

- A) Stretch it vertically by a factor of 3. Reflect it across the y-axis. Shift it 3 units horizontally to the left.
- B) Stretch it vertically by a factor of 3. Reflect it across the x-axis. Shift it vertically 3 units upward.
- C) Shrink it vertically by a factor of $\frac{1}{3}$. Reflect it across the x-axis. Shift it vertically 3 units downward.
- D) Stretch it vertically by a factor of 3. Reflect it across the x-axis. Shift it 3 units horizontally to the right.

Answer: B

202) How can the graph of $f(x) = (x - 7)^2 - 8$ be obtained from the graph of $y = x^2$?

- A) Shift it 7 units horizontally to the left. Shift it vertically 8 units downward.
- B) Shift it 8 units horizontally to the right. Shift it vertically 7 units downward.
- C) Shift it 7 units horizontally to the right. Shift it vertically 8 units downward.
- D) Shift it 7 units horizontally to the left. Shift it vertically 8 units upward.

Answer: C

203) How can the graph of $f(x) = -7x^3 + 8$ be obtained from the graph of $y = x^3$?

- A) Stretch it vertically by a factor of 7. Reflect it across the x-axis. Shift it vertically 8 units upward.
- B) Stretch it horizontally by a factor of 8. Reflect it across the x-axis. Shift it vertically 7 units upward.
- C) Stretch it vertically by a factor of 7. Reflect it across the y-axis. Shift it vertically 8 units upward.
- D) Stretch it horizontally by a factor of -7. Reflect it across the x-axis. Shift it vertically 8 units downward.

Answer: A

204) How can the graph of $f(x) = 0.8|x - 10| + 7.3$ be obtained from the graph of $y = |x|$?

- A) Shift it horizontally 7.3 units to the right. Stretch it vertically by a factor of 8. Shift it vertically 10 units downward.
- B) Shift it horizontally 8 units to the left. Shrink it vertically by a factor of 0.10. Shift it vertically 7.3 units upward.
- C) Shift it horizontally 10 units to the right. Shrink it vertically by a factor of 0.8. Shift it vertically 7.3 units upward.
- D) Shift it horizontally 10 units to the left. Stretch it vertically by a factor of 8. Shift it vertically 7.3 units upward.

Answer: C

205) How can the graph of $h(x) = 0.5\sqrt[3]{-x}$ be obtained from the graph of $y = \sqrt[3]{x}$?

- A) Reflect it across the x-axis. Shrink it vertically by a factor of 0.5.
- B) Reflect it across the y-axis. Stretch it vertically by a factor of 5.
- C) Reflect it across the y-axis. Shrink it vertically by a factor of 0.5.
- D) Reflect it across the x-axis. Stretch it vertically by a factor of 5.

Answer: C

- 206) How can the graph of $f(x) = -\sqrt[3]{x+7}$ be obtained from the graph of $y = \sqrt[3]{x}$?
- A) Shift it horizontally 7 units to the right. Reflect it across the x-axis.
 - B) Shift it horizontally 7 units to the left. Reflect it across the x-axis.
 - C) Shift it horizontally 7 units to the left. Reflect it across the y-axis.
 - D) Shift it vertically 7 units upward. Reflect it across the x-axis.

Answer: B

- 207) How can the graph of $f(x) = \frac{1}{5}\sqrt[3]{x} - 6$ be obtained from the graph of $y = \sqrt[3]{x}$?

- A) Shrink it vertically by a factor of $\frac{1}{5}$. Shift it vertically 6 units downward.
- B) Shrink it vertically by a factor of $\frac{1}{5}$. Shift it horizontally 6 units to the right.
- C) Stretch it vertically by a factor of 5. Shift it vertically 6 units downward.
- D) Shrink it vertically by a factor of $\frac{1}{5}$. Shift it horizontally 6 units to the left.

Answer: A

- 208) How can the graph of $f(x) = 0.7^{|-x|} - 10$ be obtained from the graph of $y = |x|^7$?
- A) Reflect it across the x-axis. Stretch it horizontally by a factor of 10. Shift it horizontally 7 units to the left.
 - B) Reflect it across the y-axis. Shrink it vertically by a factor of 0.7. Shift it vertically 10 units upward.
 - C) Reflect it across the x-axis. Stretch it vertically by a factor of 7. Shift it horizontally 10 units to the right.
 - D) Reflect it across the y-axis. Shrink it vertically by a factor of 0.7. Shift it vertically 10 units downward.

Answer: D

- 209) How can the graph of $f(x) = \frac{1}{2}(x+10)^2 - 5$ be obtained from the graph of $y = x^2$?

- A) Shift it horizontally 10 units to the left. Shrink it vertically by a factor of 2. Shift it 5 units down.
- B) Shift it horizontally 10 units to the right. Stretch it vertically by a factor of 2. Shift it 5 units up.
- C) Shift it horizontally 10 units to the right. Shrink it vertically by a factor of $\frac{1}{2}$. Shift it 5 units down.
- D) Shift it horizontally 10 units to the left. Shrink it vertically by a factor of $\frac{1}{2}$. Shift it 5 units down.

Answer: D

- 210) How can the graph of $f(x) = \frac{12}{x} + 6$ be obtained from the graph of $y = \frac{1}{x}$?

- A) Shrink it vertically a factor of $\frac{1}{12}$. Shift it 6 units up.
- B) Stretch it vertically by a factor of 12. Shift it 6 units up.
- C) Shift it horizontally 12 units to the right. Shift it 6 units up.
- D) Shift it horizontally 12 units to the left. Shift it 6 units down.

Answer: B

211) How can the graph of $f(x) = \frac{1}{x+11} - 4$ be obtained from the graph of $y = \frac{1}{x}$?

- A) Shrink it horizontally by a factor of $\frac{1}{2}$. Shift it 4 units down.
- B) Shift it horizontally 11 units to the left. Shift it 4 units down.
- C) Shift it horizontally 11 units to the right. Stretch it vertically by a factor of 4.
- D) Shift it horizontally 11 units to the left. Shift it 4 units up.

Answer: B

212) How can the graph of $f(x) = \frac{1}{-x} - 9$ be obtained from the graph of $y = \frac{1}{x}$?

- A) Reflect it across the y -axis. Shift it 9 units down.
- B) Reflect it across the x -axis. Shift it 9 units up.
- C) Reflect it across the y -axis. Shift it 9 units up.
- D) Reflect it across the x -axis. Shift it 9 units down.

Answer: A

213) How can the graph of $f(x) = -\frac{1}{x} + 1$ be obtained from the graph of $y = \frac{1}{x}$?

- A) Reflect it across the y -axis. Shift it 1 units up.
- B) Reflect it across the x -axis. Shift it 1 units up.
- C) Reflect it across the x -axis. Shift it 1 units down.
- D) Reflect it across the y -axis. Shift it 1 units down.

Answer: B

214) How can the graph of $f(x) = -(x-6)^2 + 10$ be obtained from the graph of $y = x^2$?

- A) Shift it horizontally 6 units to the right. Reflect it across the x -axis. Shift it 10 units up.
- B) Shift it horizontally 6 units to the right. Reflect it across the y -axis. Shift it 10 units up.
- C) Shift it horizontally 6 units to the right. Reflect it across the y -axis. Shift it 10 units down.
- D) Shift it horizontally 6 units to the left. Reflect it across the x -axis. Shift it 10 units up.

Answer: A

215) How can the graph of $f(x) = 0.2(x+1)^2 - 12$ be obtained from the graph of $y = x^2$?

- A) Shift it horizontally 1 units to the right. Shrink it vertically by a factor of 0.2. Shift it 12 units up.
- B) Shift it horizontally 12 units to the left. Stretch it vertically by a factor of 4. Shift it 1 units down.
- C) Shift it horizontally 1 units to the left. Shrink it horizontally by a factor of 0.2. Shift it 12 units down.
- D) Shift it horizontally 1 units to the left. Shrink it vertically by a factor of 0.2. Shift it 12 units down.

Answer: D

Graph the function.

216) $f(x) = x^2 - 6$

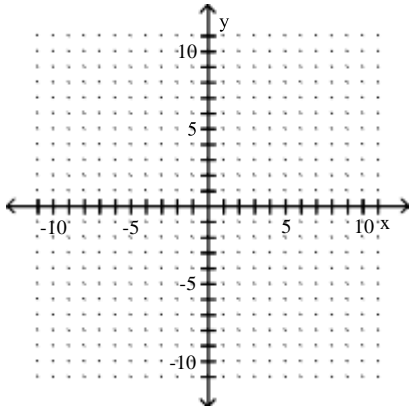

A)

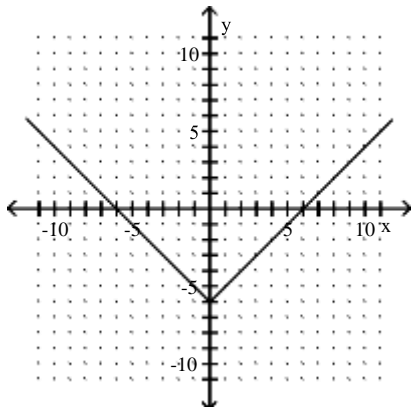

B)

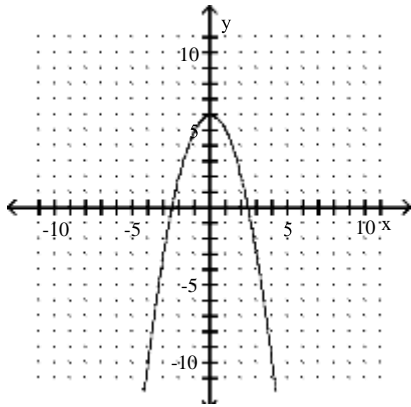

C)

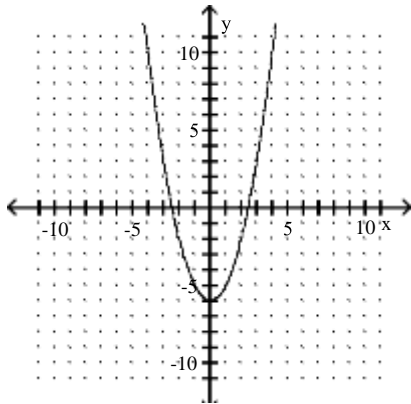

D)

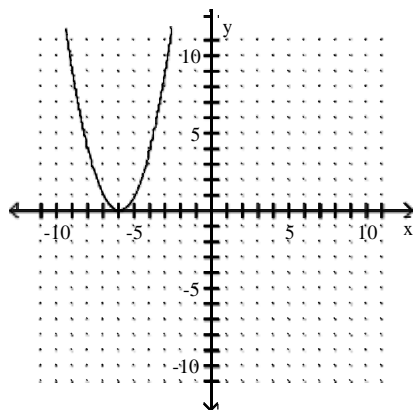

Answer: C

217) $f(x) = |x - 4|$

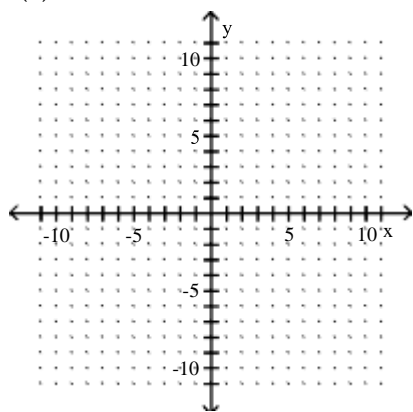

A)

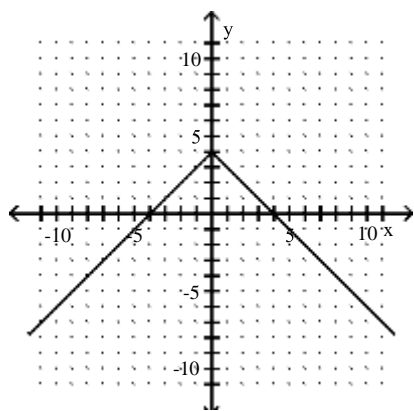

B)

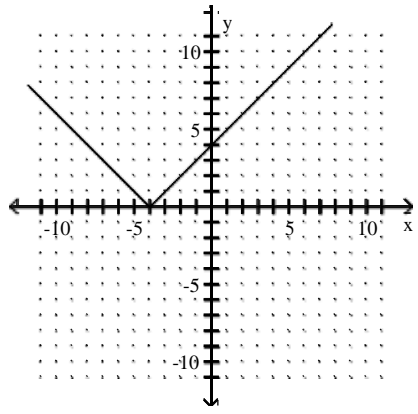

C)

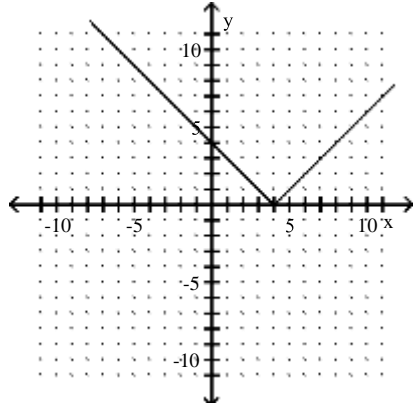

D)

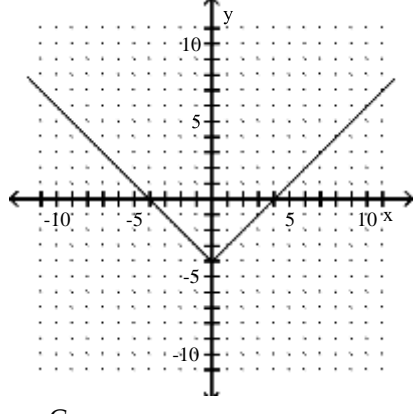

Answer: C

218) $g(x) = -3|x|$

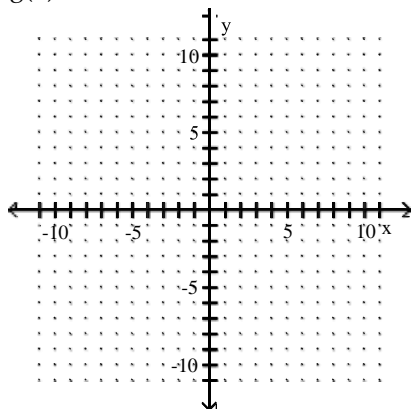

A)

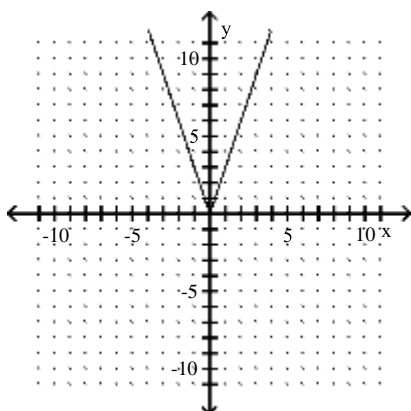

B)

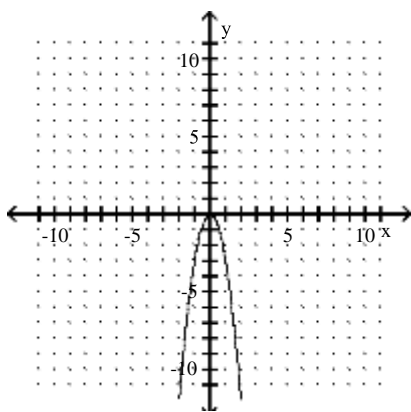

C)

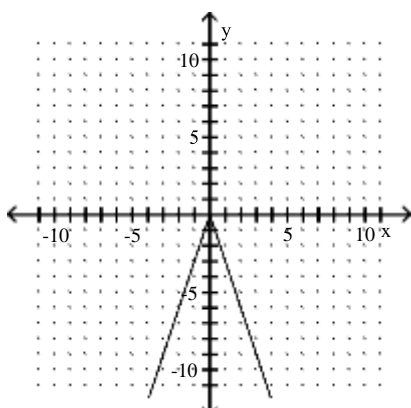

D)

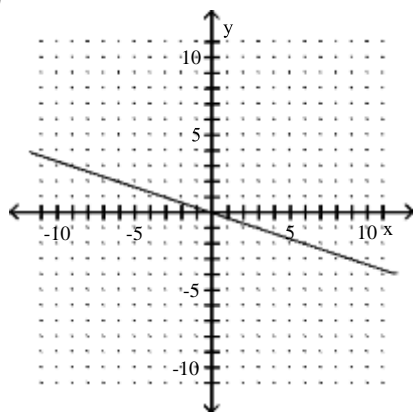

Answer: C

219) $h(x) = (x - 4)^2 - 2$

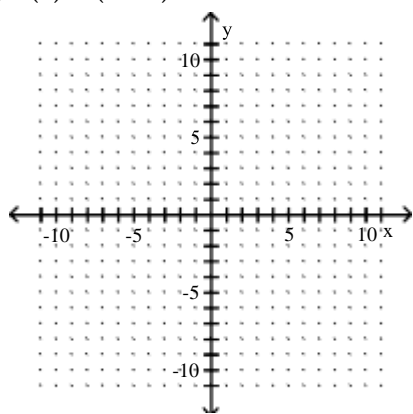

A)

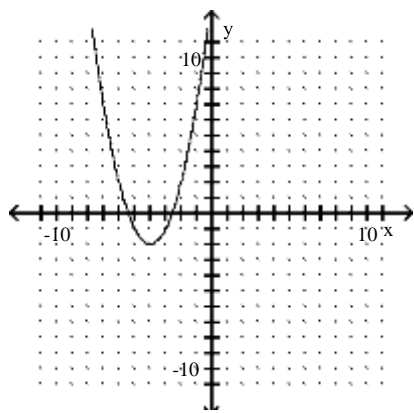

B)

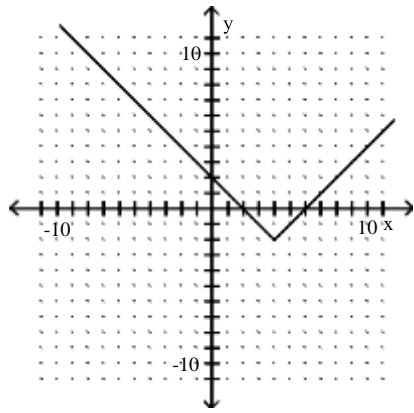

C)

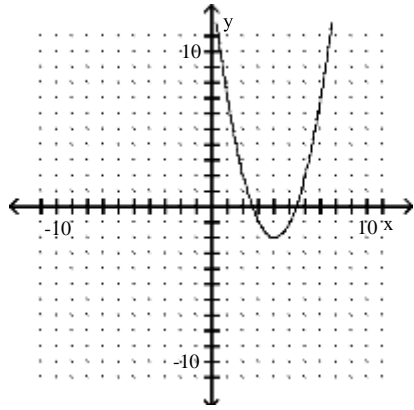

D)

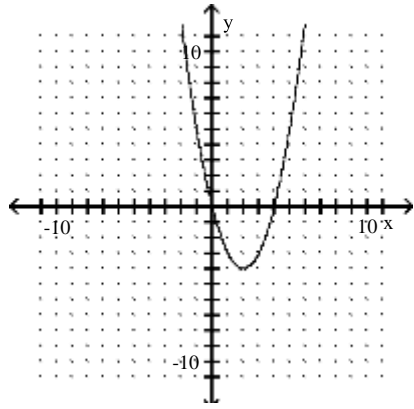

Answer: C

220) $f(x) = -3(x + 2)^2 + 3$

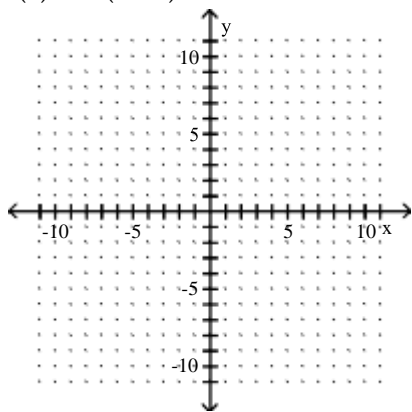

A)

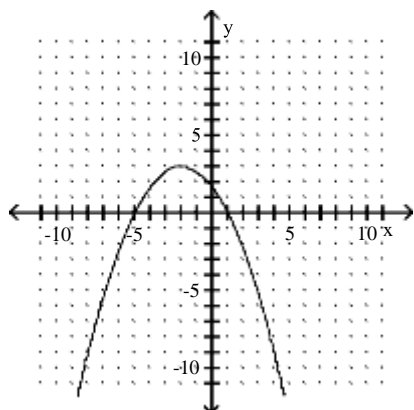

B)

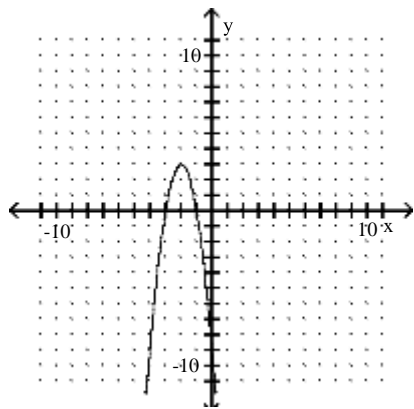

C)

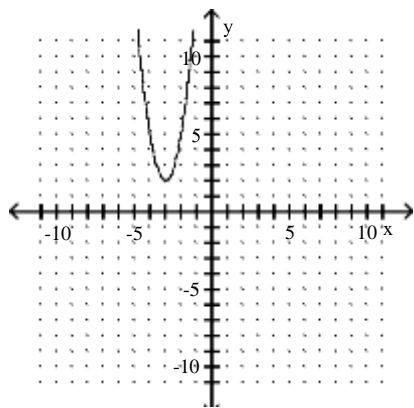

D)

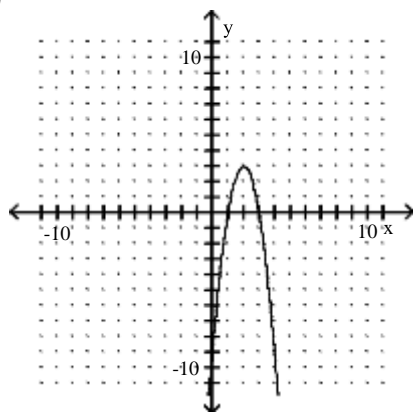

Answer: B

$$221) h(x) = \frac{1}{4}|x + 4| - 5$$

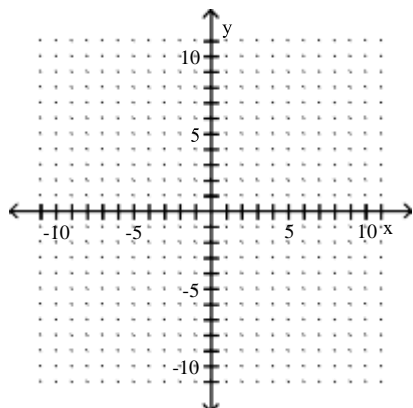

A)

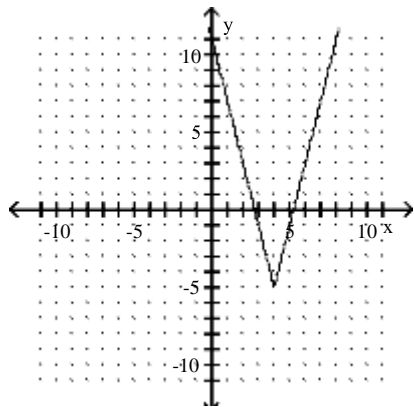

B)

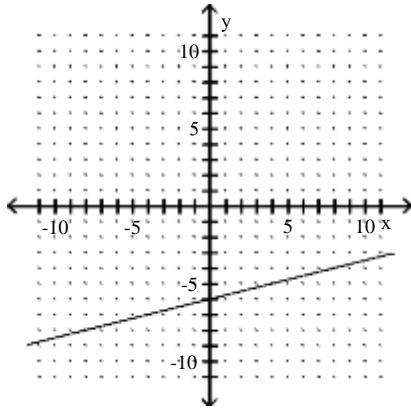

C)

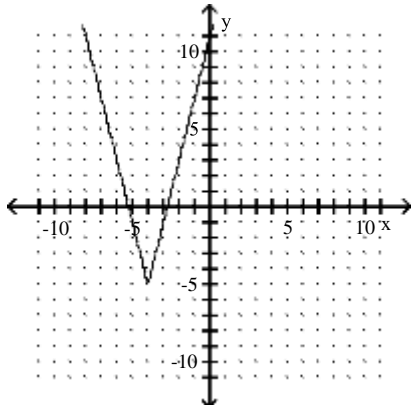

D)

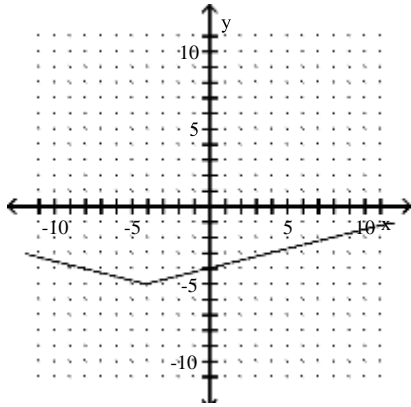

Answer: D

222) $g(x) = (x + 2)^3$

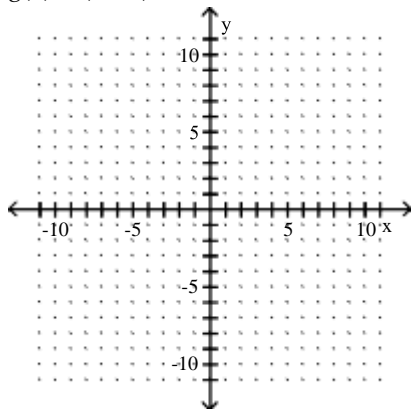

A)

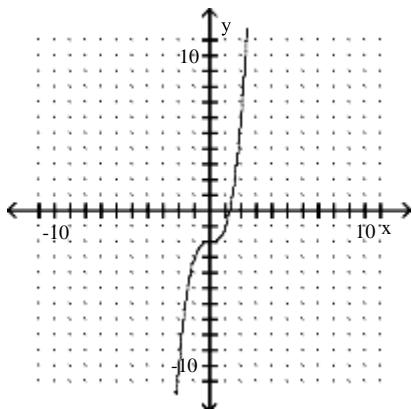

B)

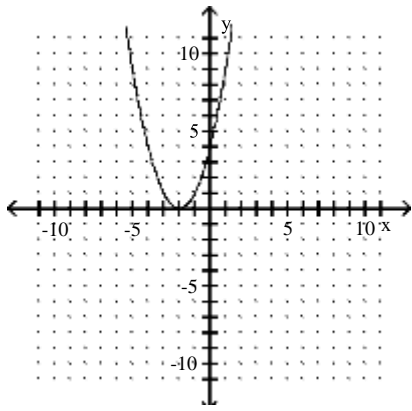

C)

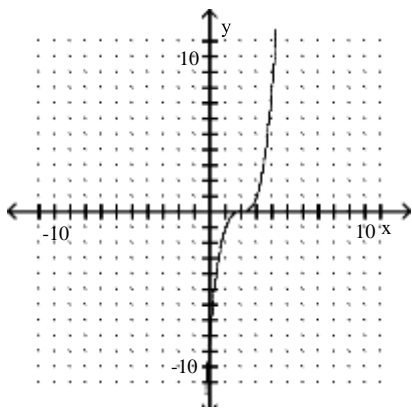

D)

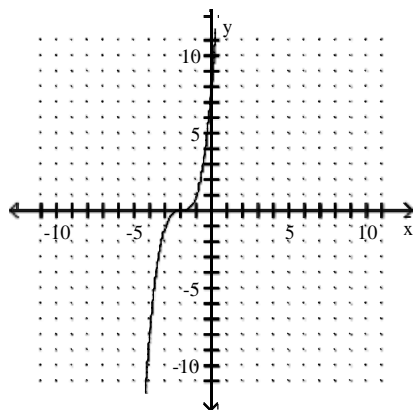

Answer: D

223) $g(x) = \sqrt[3]{x} + 5$

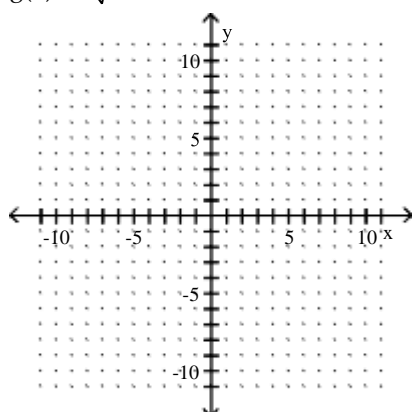

A)

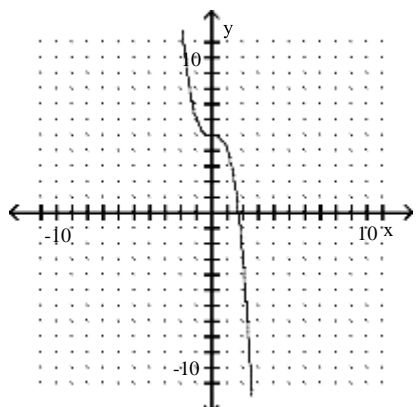

B)

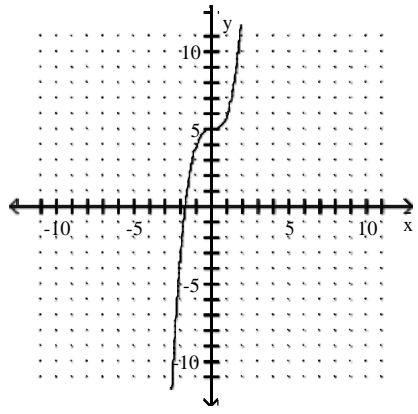

C)

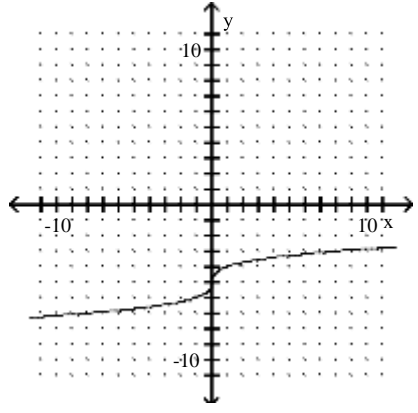

D)

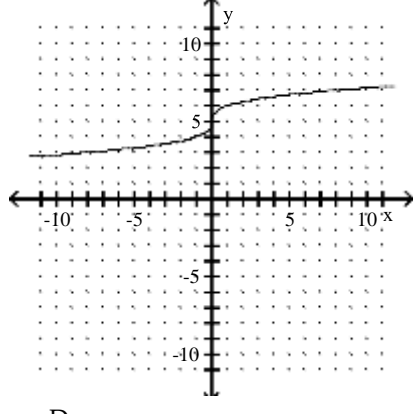

Answer: D

224) $f(x) = \sqrt{x+1}$

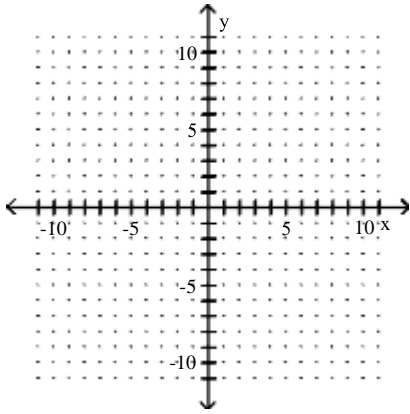

A)

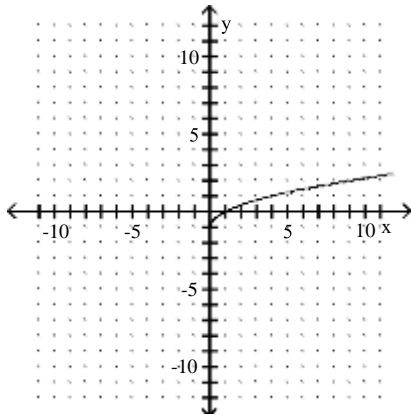

B)

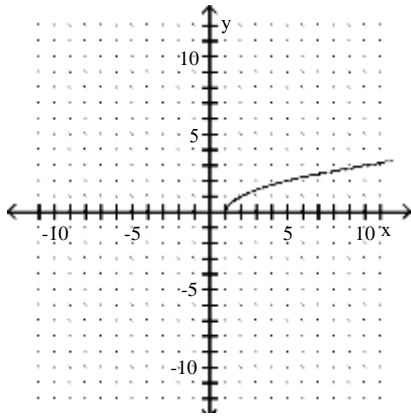

C)

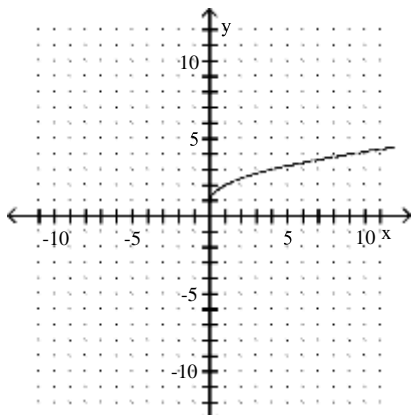

D)

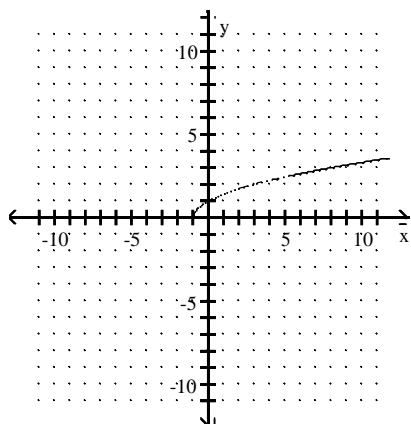

Answer: D

225) $f(x) = (x - 6)^3 + 7$

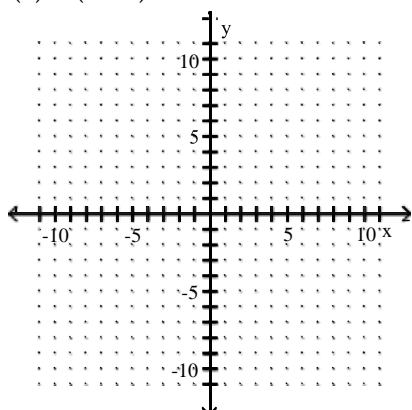

A)

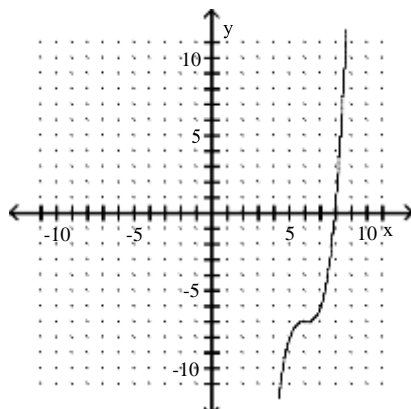

B)

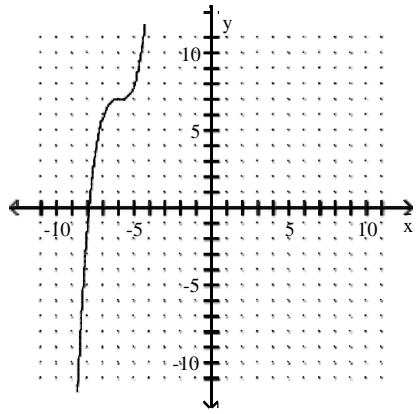

C)

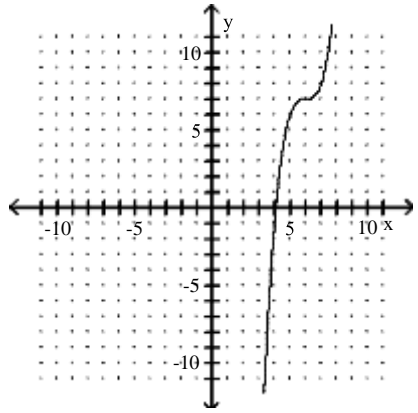

D)

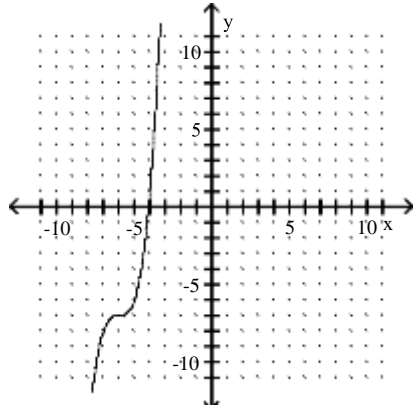

Answer: C

226) $f(x) = \frac{1}{x} + 4$

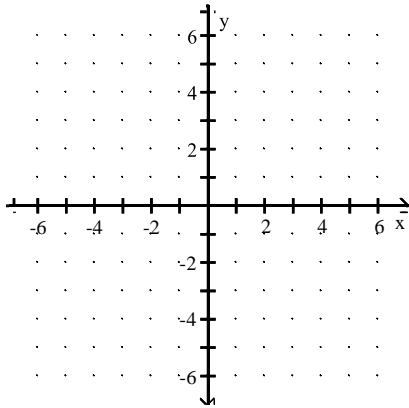

A)

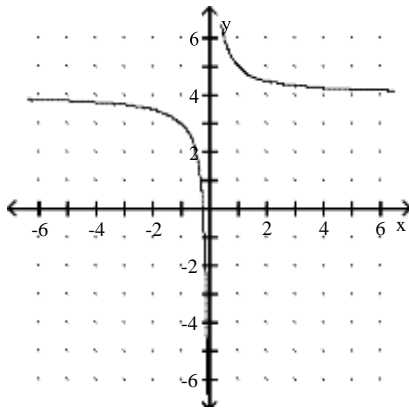

B)

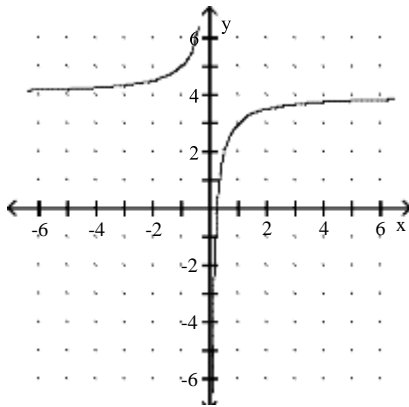

C)

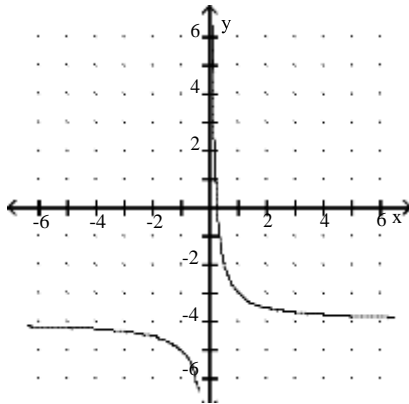

D)

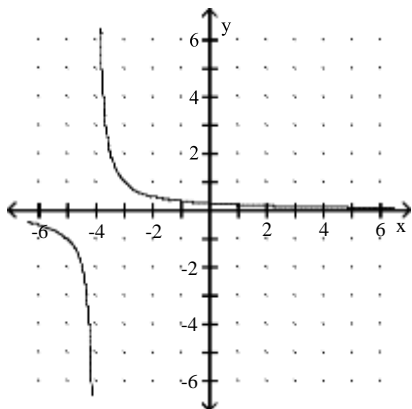

Answer: A

227) $f(x) = \frac{1}{x - 2}$

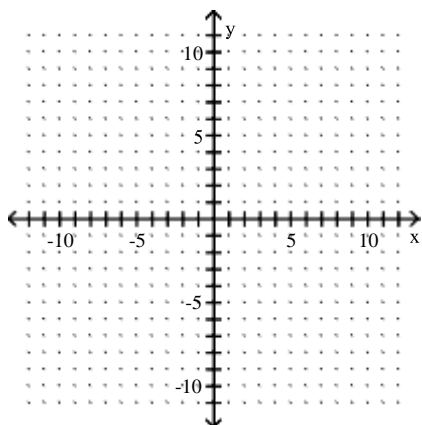

A)

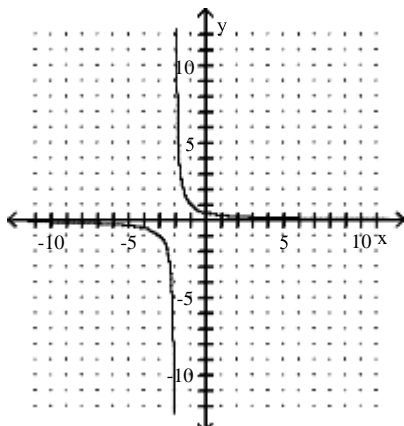

B)

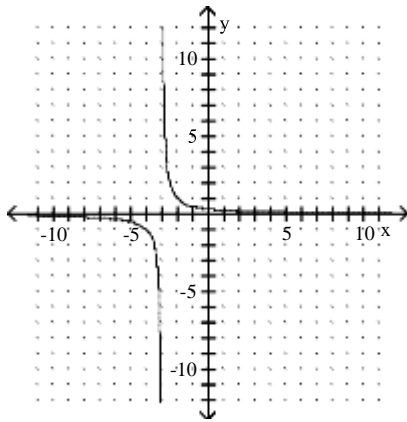

C)

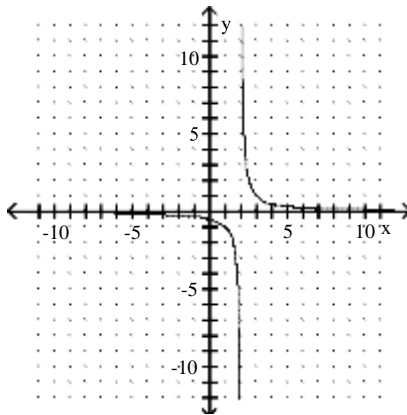

D)

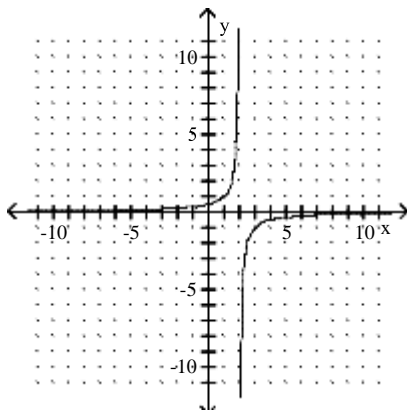

Answer: C

The given point is on the graph of $y = f(x)$. Find a point on the graph of $y = g(x)$.

228) $g(x) = f(x) + 1$; $(5, 12)$

- A) $(5, 17)$
- B) $(5, 13)$
- C) $(5, 11)$
- D) $(5, 14)$

Answer: B

229) $g(x) = f(x) - 4$; (4, 13)

- A) (4, 9)
- B) (4, 7)
- C) (4, 10)
- D) (4, 13)

Answer: A

230) $g(x) = f(x - 1)$; (7, 20)

- A) (7, 21)
- B) (8, 20)
- C) (6, 20)
- D) (7, 19)

Answer: B

231) $g(x) = f(x + 1)$; (2, 8)

- A) (2, 7)
- B) (1, 8)
- C) (3, 8)
- D) (2, 9)

Answer: B

232) $g(x) = f(x - 1) + 3$; (3, 9)

- A) (10, 6)
- B) (10, 12)
- C) (4, 6)
- D) (4, 12)

Answer: D

233) $g(x) = \frac{1}{2}f(x)$; (-2, 6)

- A) (-2, 3)
- B) (1, 3)
- C) (-2, -3)
- D) (-1, -3)

Answer: A

234) $g(x) = f\left(-\frac{1}{8}x\right)$; (5, -8)

- A) $\left(-\frac{5}{8}, -5\right)$
- B) (-40, -8)
- C) $\left(\frac{1}{40}, 5\right)$
- D) (40, 8)

Answer: B

235) $g(x) = 2f(x)$; (2, 4)

- A) (1, 4)
- B) (5, 1)
- C) (2, 8)
- D) (4, 4)

Answer: C

236) $g(x) = f(-2x)$; (4, -2)

- A) $\left(-\frac{4}{2}, -2\right)$
- B) (-8, -2)
- C) $\left(\frac{4}{8}, -4\right)$
- D) (8, 2)

Answer: A

Given the function f, match the function g with a transformation of f.

237) $f(x) = x^2 - 1$, $g(x) = (x - 5)^2 - 1$

- A) $f(x) + 5$
- B) $f(x - 5)$
- C) $f(x) - 5$
- D) $f(x + 5)$

Answer: B

238) $f(x) = x^2 + 2$, $g(x) = x^2 + 5$

- A) $f(x) + 3$
- B) $f(x - 3)$
- C) $f(x) - 3$
- D) $f(x + 3)$

Answer: A

239) $f(x) = x^2 - 7$, $g(x) = 3x^2 - 21$

- A) $f(x) + 3$
- B) $3f(x)$
- C) $f(x + 3)$
- D) $f(3x)$

Answer: B

240) $f(x) = x^2 - 9$, $g(x) = 4x^2 - 9$

- A) $f(x + 2)$
- B) $2f(x)$
- C) $f(x) + 2$
- D) $f(2x)$

Answer: D

Write an equation for a function that has a graph with the given characteristics.

241) The shape of $y = x^2$, but upside-down and vertically stretched by a factor of 10.

A) $f(x) = 10(x - 10)x^2$

B) $f(x) = 10x^2$

C) $f(x) = -10x^2$

D) $f(x) = (x - 10)^2$

Answer: C

242) The shape of $y = x^3$ is shifted 8.2 units to the right and then vertically shrunk by a factor of 0.3.

A) $f(x) = 0.3(x + 8.2)^3$

B) $f(x) = 0.3(x - 8.2)^3$

C) $f(x) = 0.3x^3 + 8.2$

D) $f(x) = 8.2(x - 0.3)^3$

Answer: B

243) The shape of $y = |x|$ is vertically stretched by a factor of 1.5. This graph is then reflected across the x-axis. Finally, the graph is shifted 0.19 units downward.

A) $f(x) = 1.5|x - 0.19|$

B) $f(x) = -1.5|x| - 0.19$

C) $f(x) = 1.5|x| - 0.19$

D) $f(x) = 1.5|-x| - 0.19$

Answer: B

244) The shape of $y = \sqrt[3]{x}$ is shifted 8.3 units to the left. This graph is then vertically stretched by a factor of 4.4. Finally, the graph is reflected across the x-axis.

A) $f(x) = 4.4\sqrt[3]{x + 8.3}$

B) $f(x) = -4.4\sqrt[3]{x + 8.3}$

C) $f(x) = -4.4\sqrt[3]{x - 8.3}$

D) $f(x) = -8.3\sqrt[3]{x + 4.4}$

Answer: B

245) The shape of $y = \sqrt{x}$ is shifted 10 units to the left. Then the graph is shifted 7 units upward.

A) $f(x) = 7\sqrt{x + 10}$

B) $f(x) = \sqrt{x + 10} + 7$

C) $f(x) = \sqrt{x + 7} + 10$

D) $f(x) = \sqrt{x - 10} + 7$

Answer: B

246) The shape of $y = |x|$ is reflected across the y-axis. This graph is then vertically stretched by a factor of 6.9. Finally, the graph is shifted 3 units downward.

A) $f(x) = 3|-x| - 6.9$

B) $f(x) = 6.9|-x| + 3$

C) $f(x) = -6.9|x| - 3$

D) $f(x) = 6.9|-x| - 3$

Answer: D

A graph of $y = f(x)$ follows. No formula for f is given. Graph the given equation.

247) $y = 2f(x)$

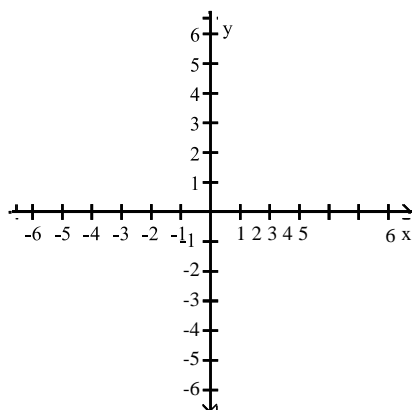
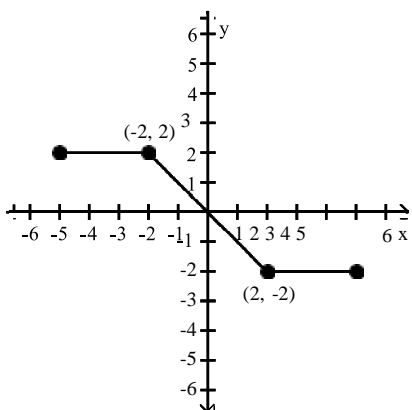

A)

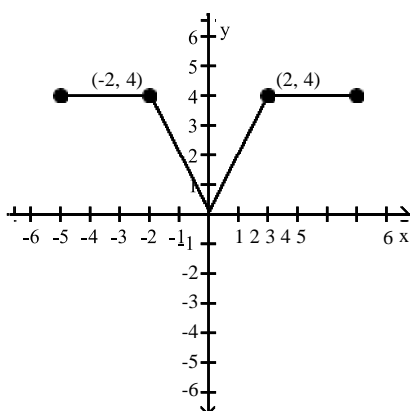

B)

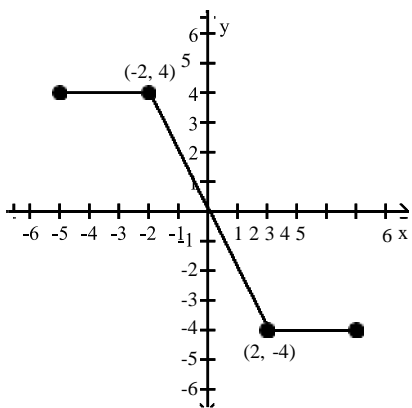

C)

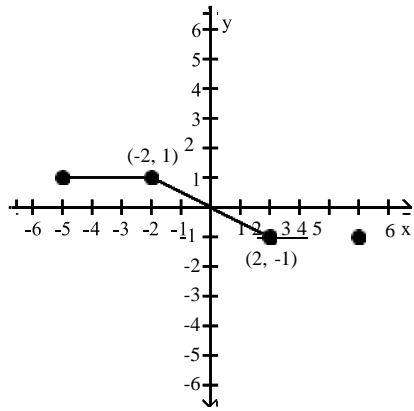

D)

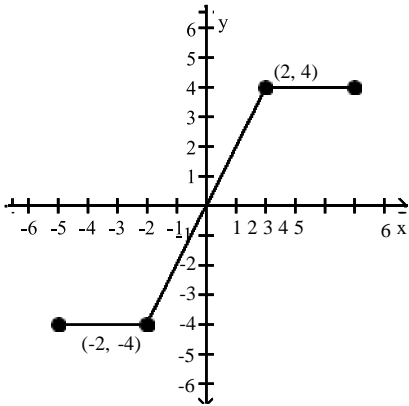

Answer: B

$$248) y = -\frac{1}{2} f(x)$$

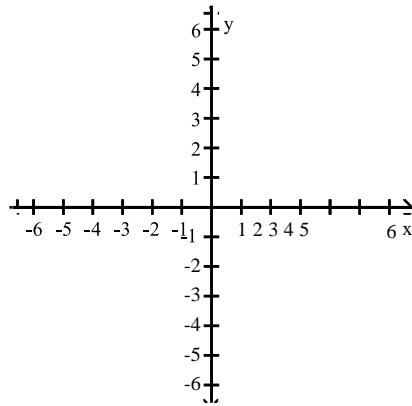
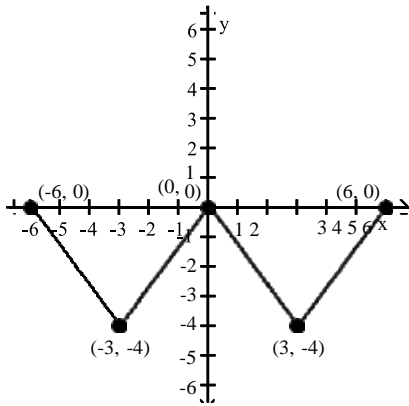

A)

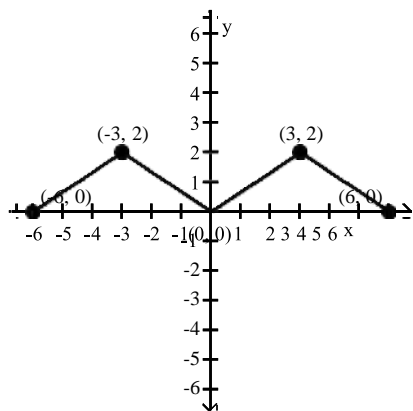

B)

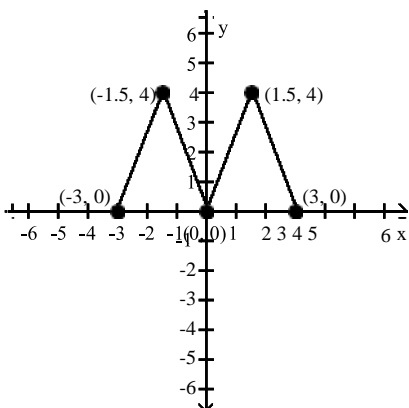

C)

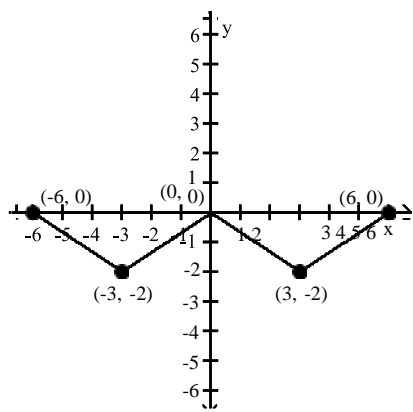

D)

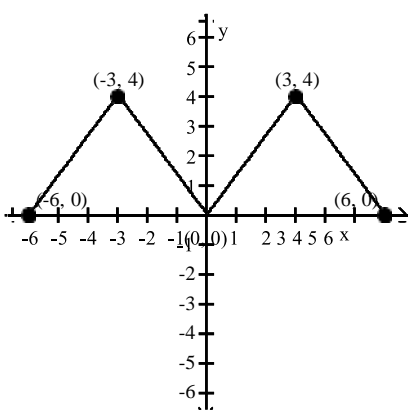

Answer: A

249) $y = f(2x)$

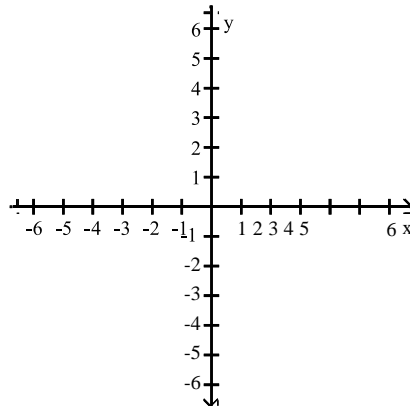
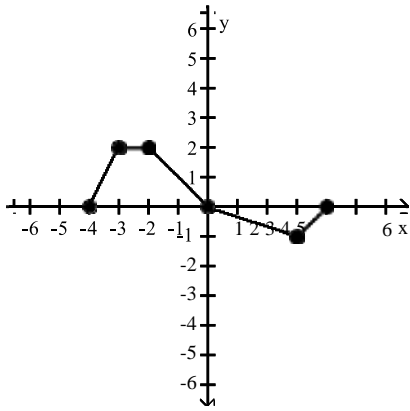

A)

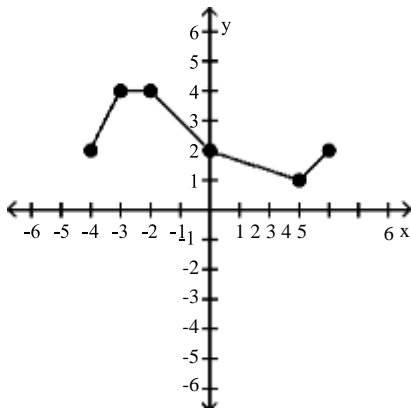

B)

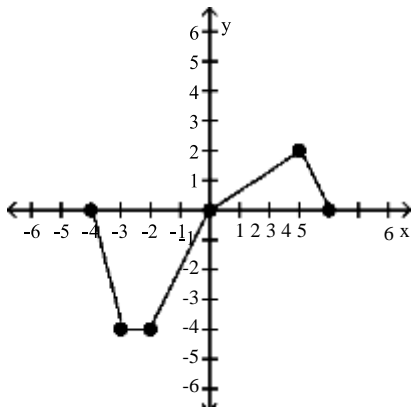

C)

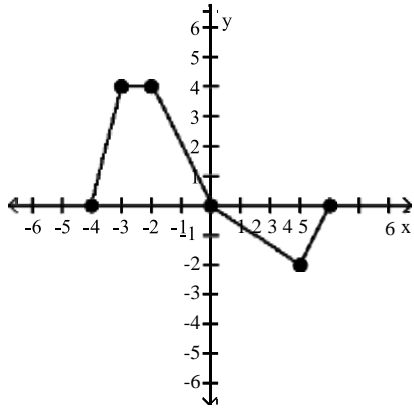

D)

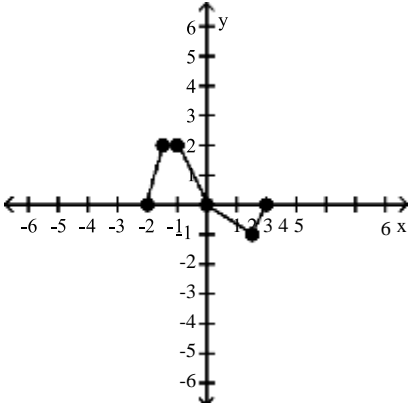

Answer: D

$$250) y = f\left(-\frac{1}{2}x\right)$$

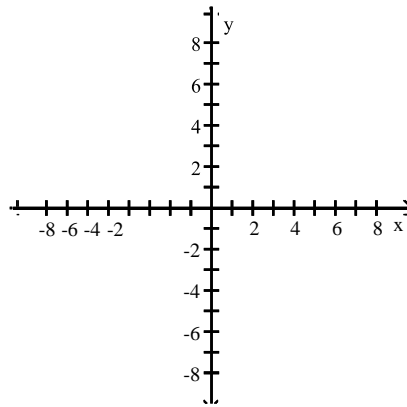
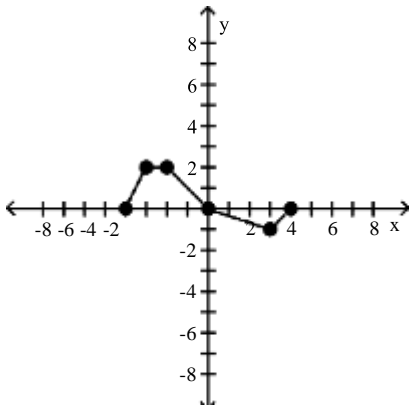

A)

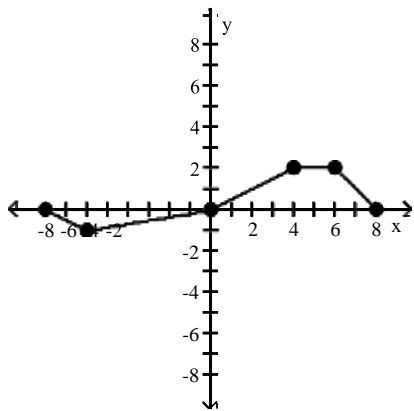

B)

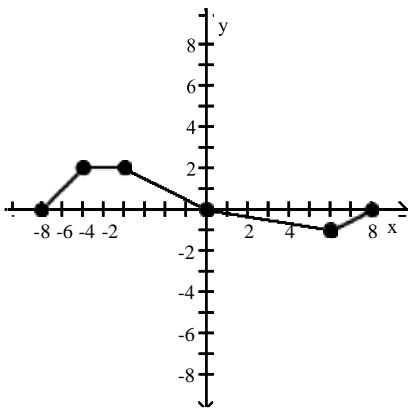

C)

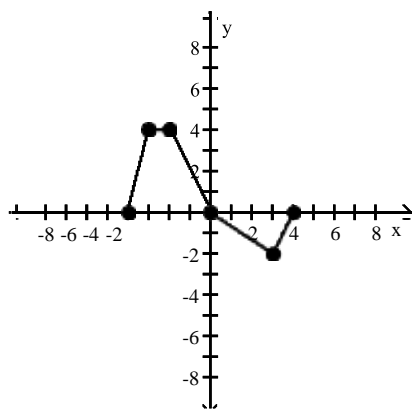

D)

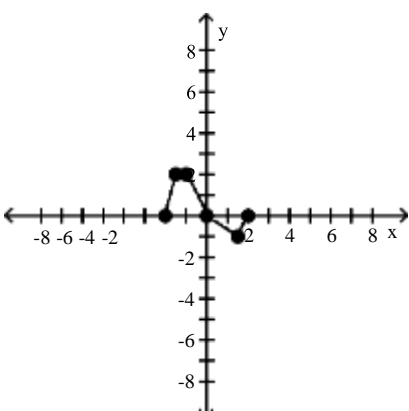

Answer: A

251) $y = -2f(x + 1) - 3$

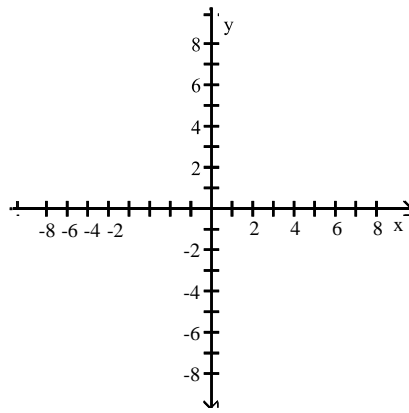
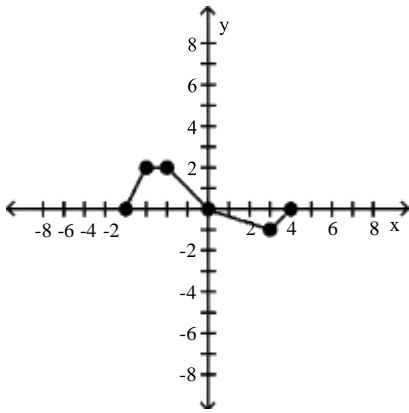

A)

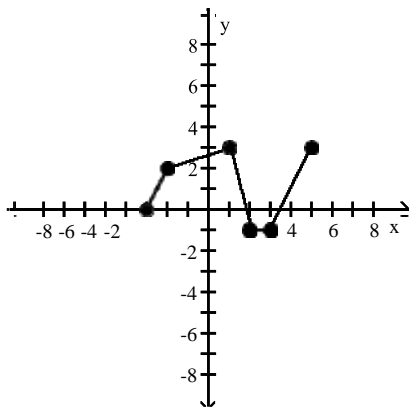

B)

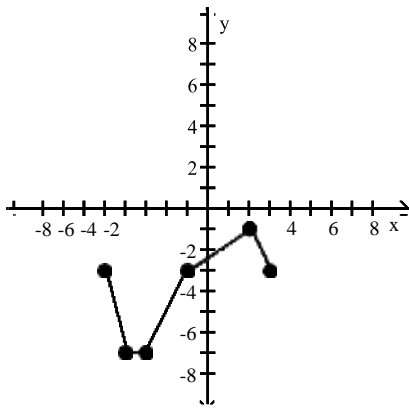

C)

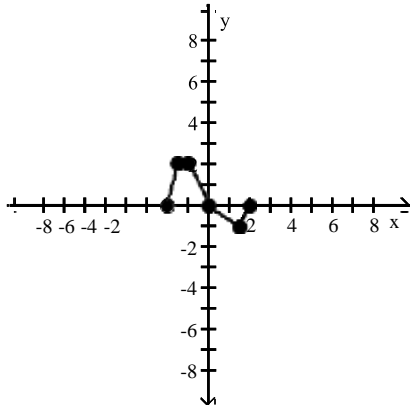

D)

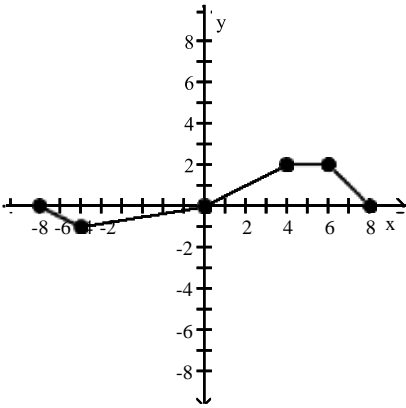

Answer: B

$$252) y = \frac{1}{2} f(x - 1) + 3$$

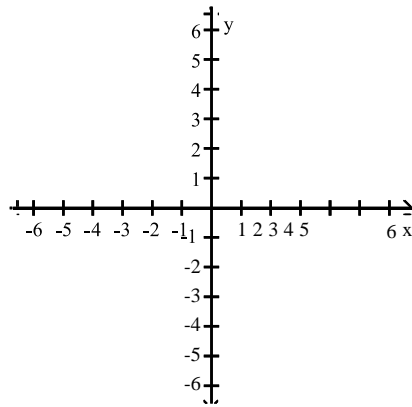
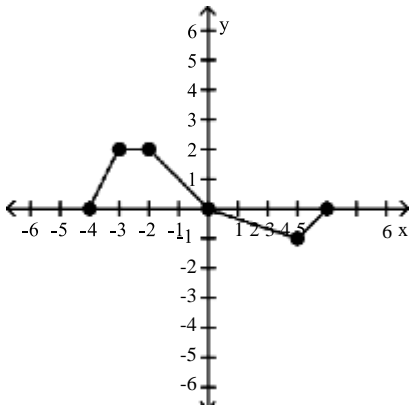

A)

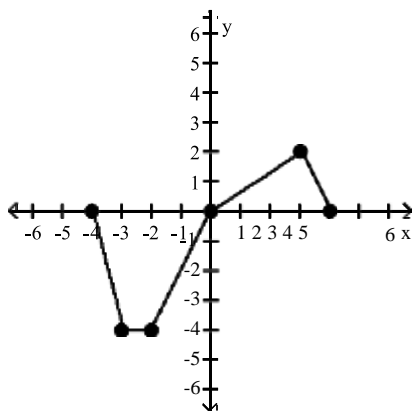

B)

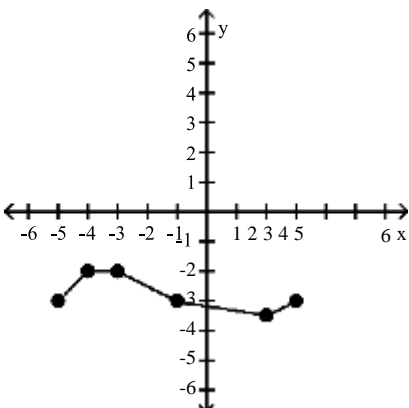

C)

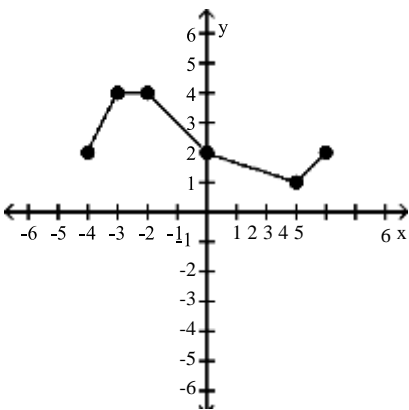

D)

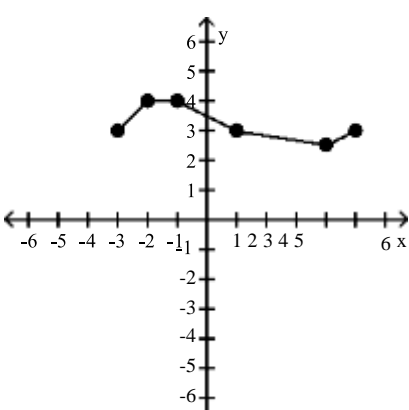

Answer: D

The graph of the function f is shown below. Match the function g with the correct graph.

253) $g(x) = f(x) + 3$

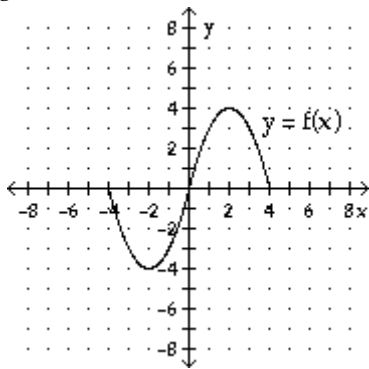

A)

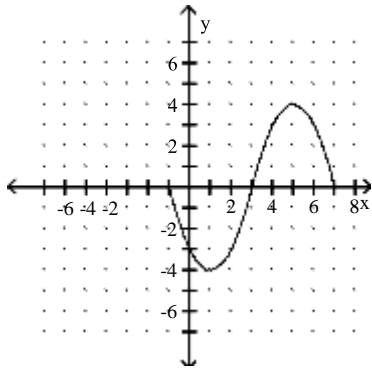

B)

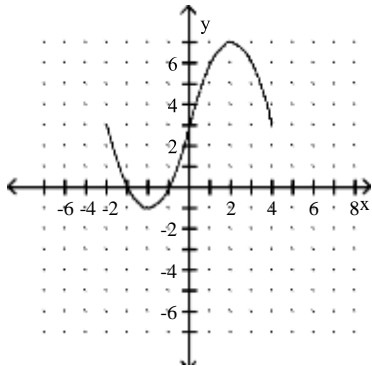

C)

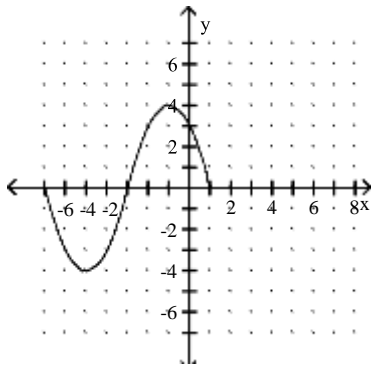

D)

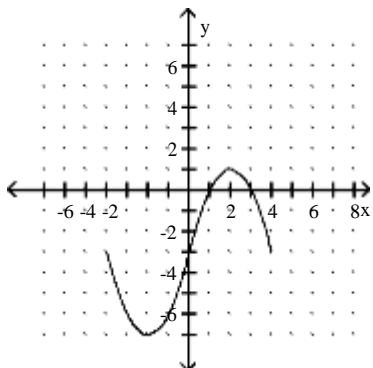

Answer: B

254) $g(x) = f(x + 3)$

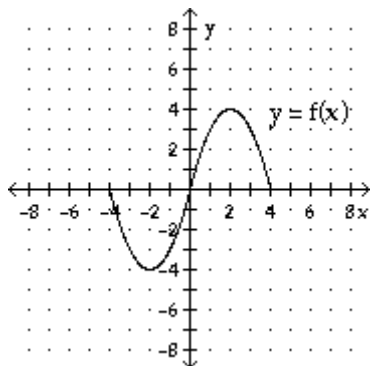

A)

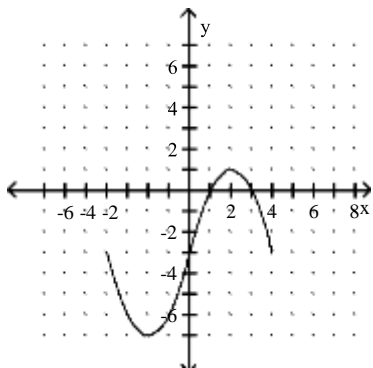

B)

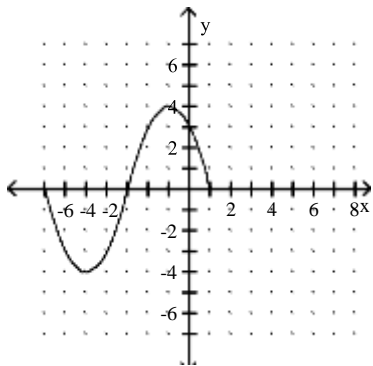

C)

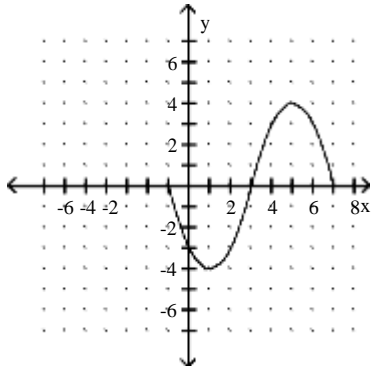

D)

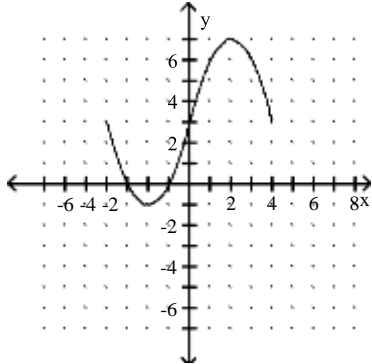

Answer: B

255) $g(x) = f(x - 4)$

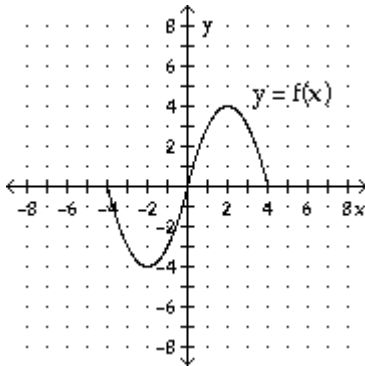

A)

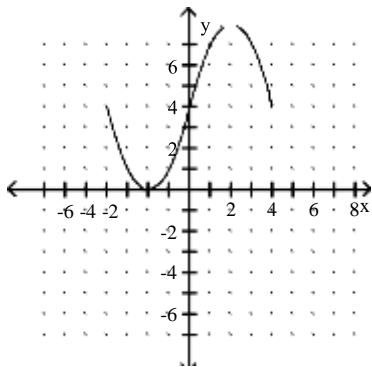

B)

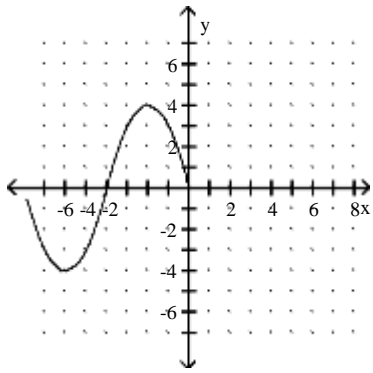

C)

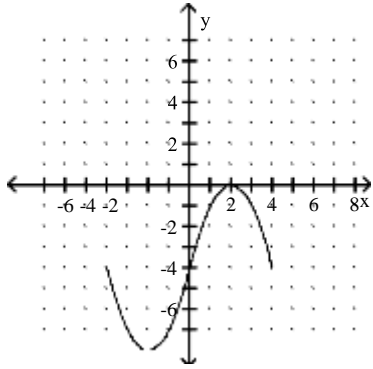

D)

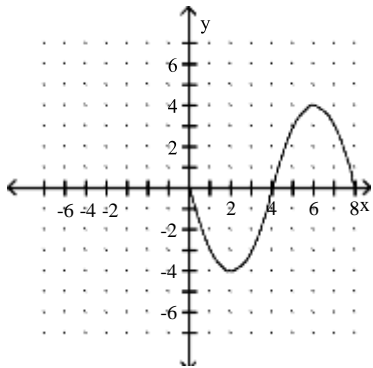

Answer: D

256) $g(x) = f(x) - 2$

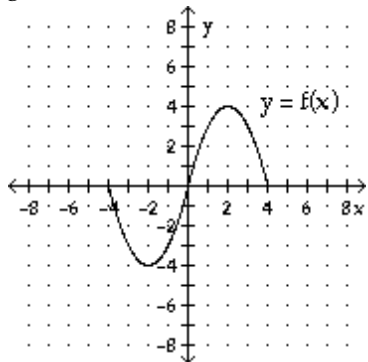

A)

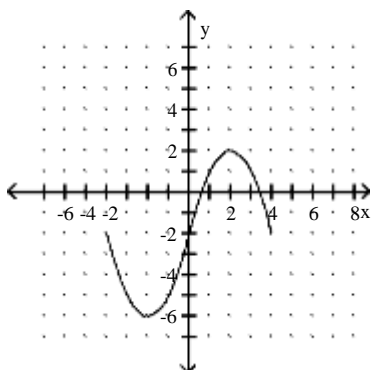

B)

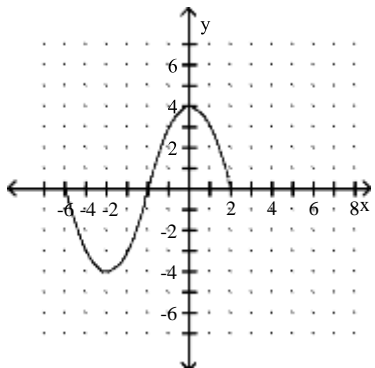

C)

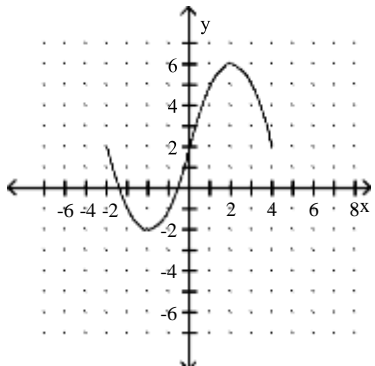

D)

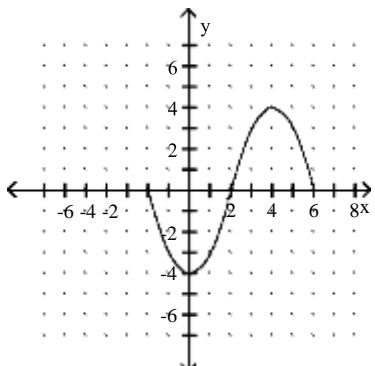

Answer: A

257) $g(x) = f(-x) + 1$

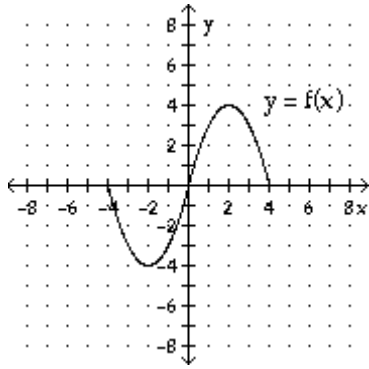

A)

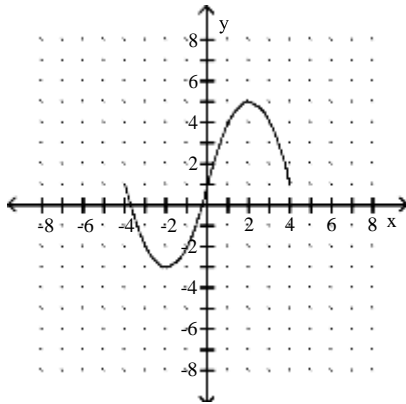

B)

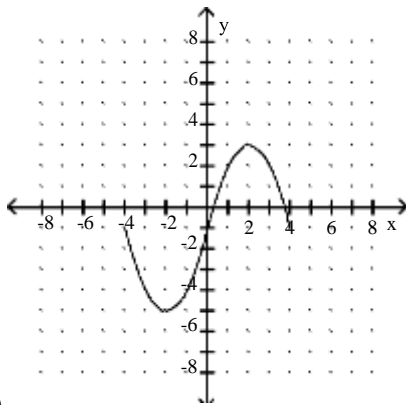

C)

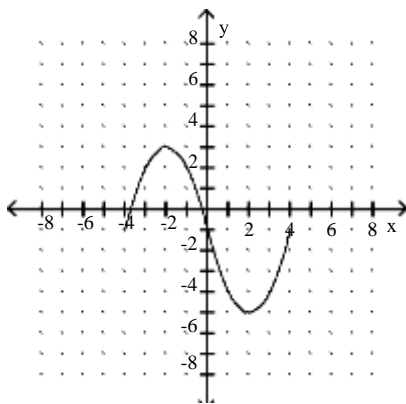

D)

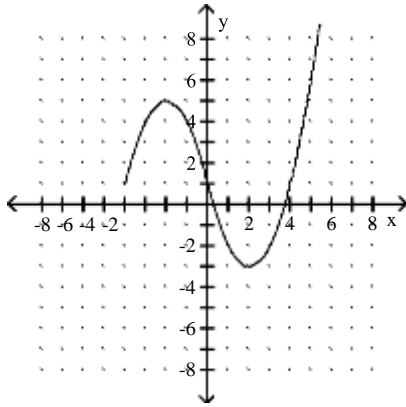

Answer: D

258) $g(x) = -f(x) - 4$

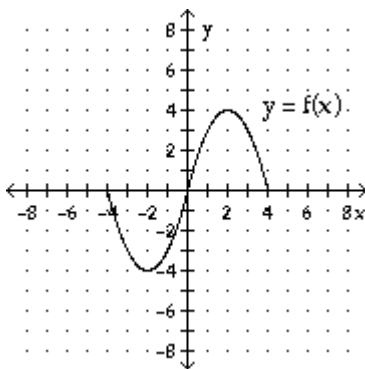

A)

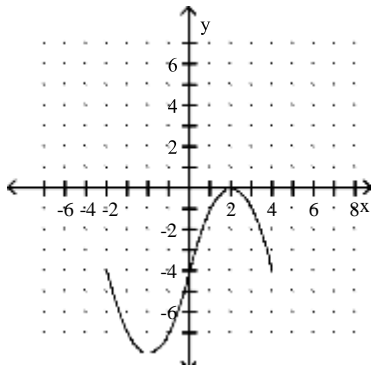

B)

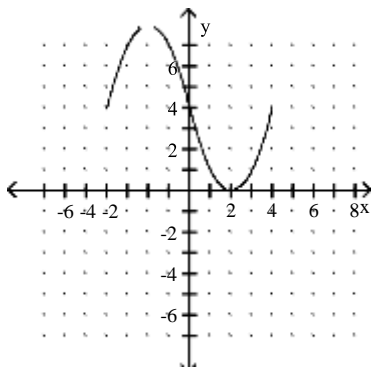

C)

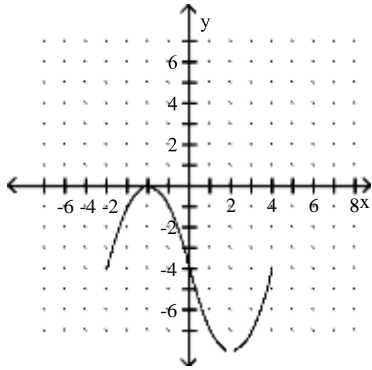

D)

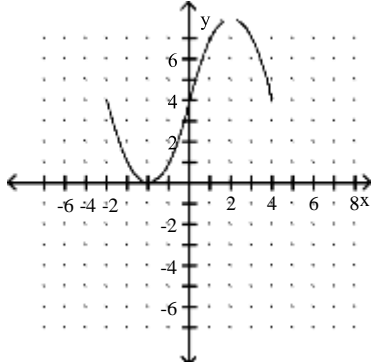

Answer: C

259) $g(x) = -f(-x) + 4$

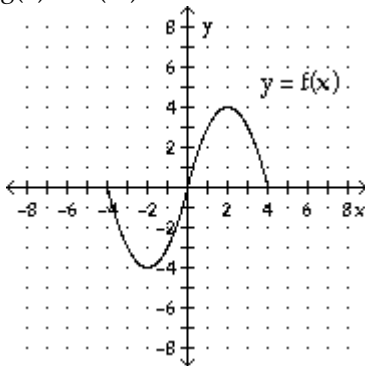

A)

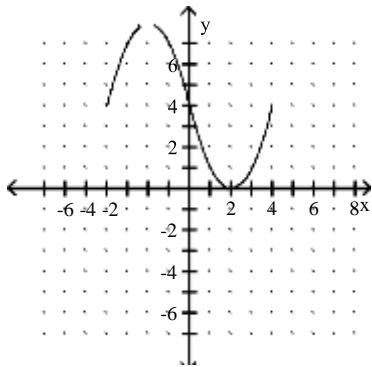

B)

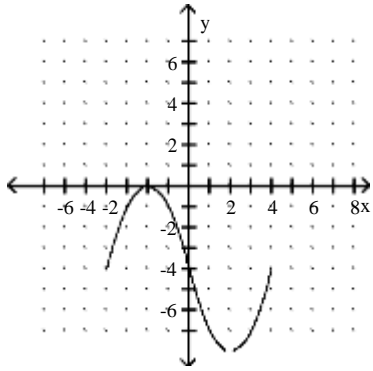

C)

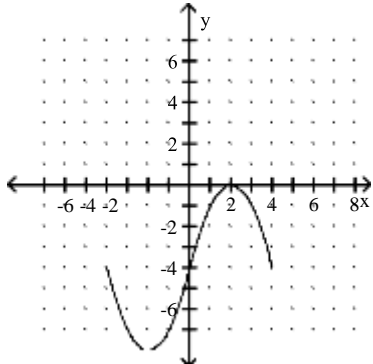

D)

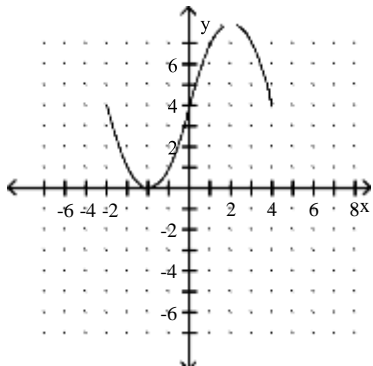

Answer: D

260) $g(x) = -f(-x) - 4$

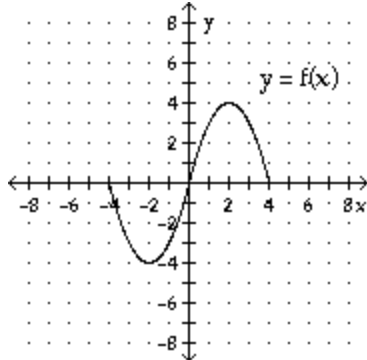

A)

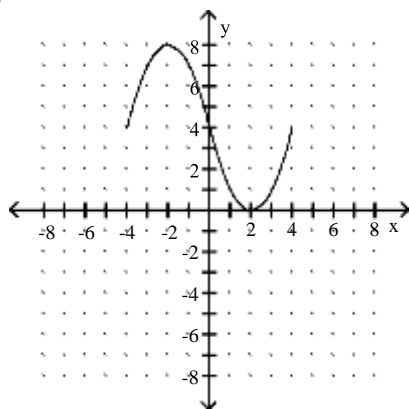

B)

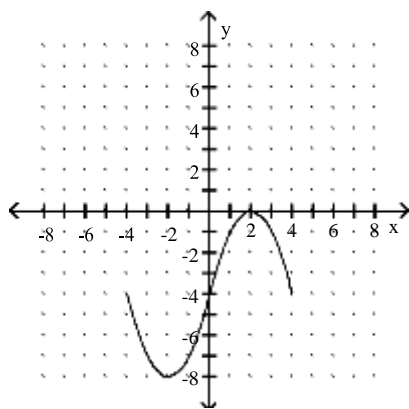

C)

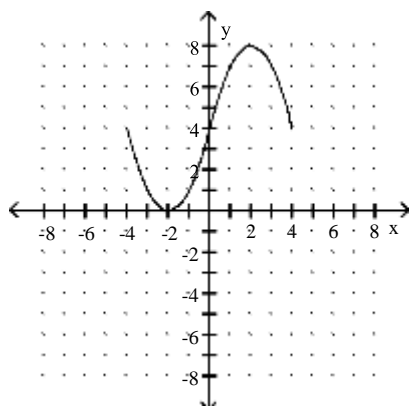

D)

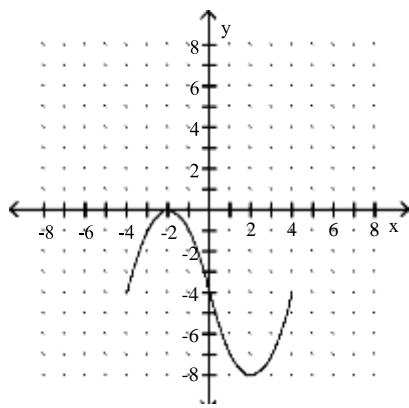

Answer: B

261) $g(x) = 2f(x)$

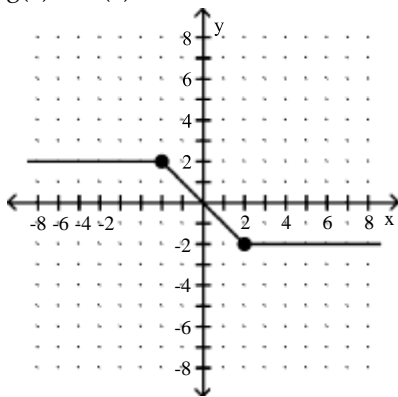

A)

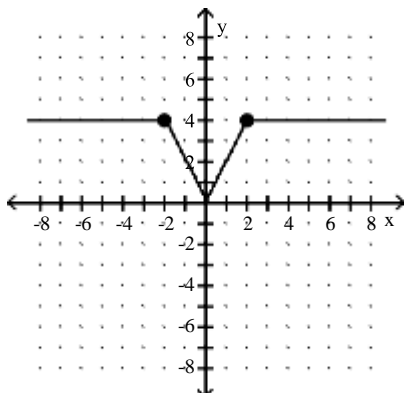

B)

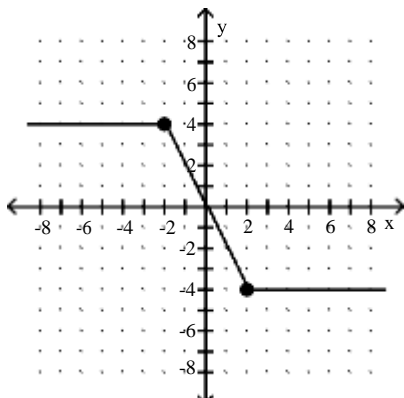

C)

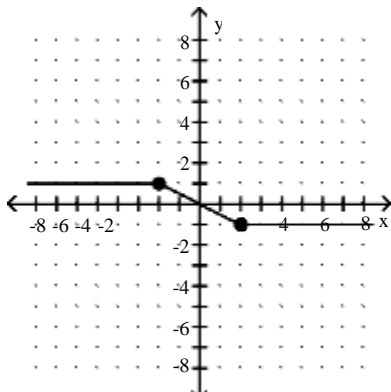

D)

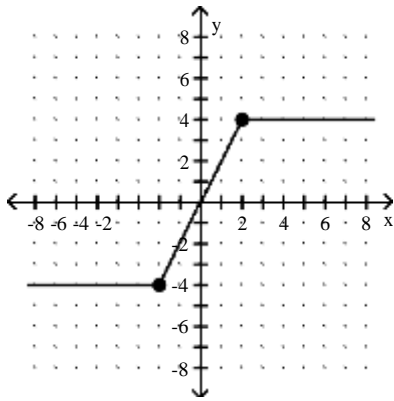

Answer: B

$$262) g(x) = -\frac{1}{2}f(x)$$

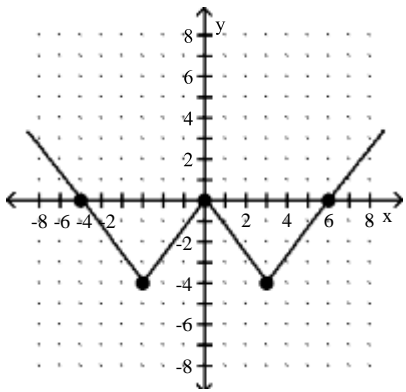

A)

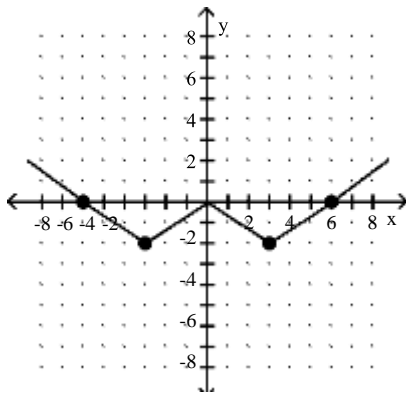

B)

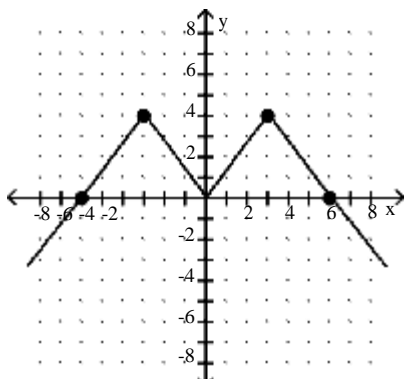

C)

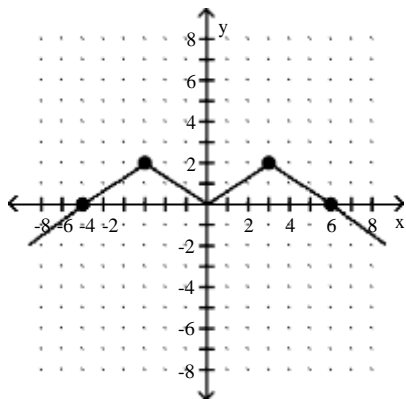

D)

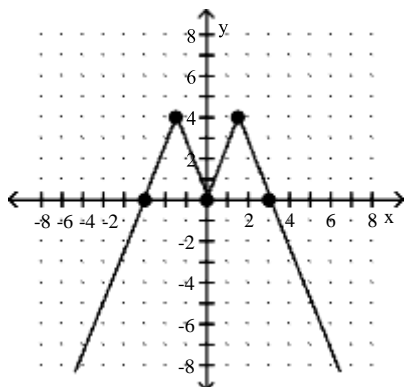

Answer: C

$$263) g(x) = -\frac{1}{4}f(x+5)^2 + 3$$

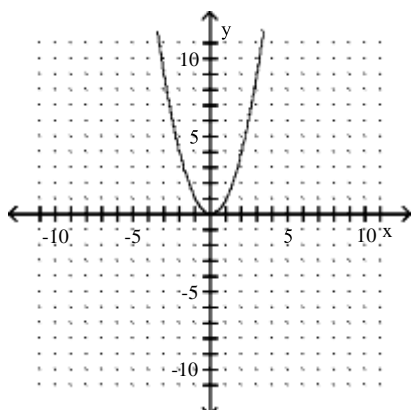

A)

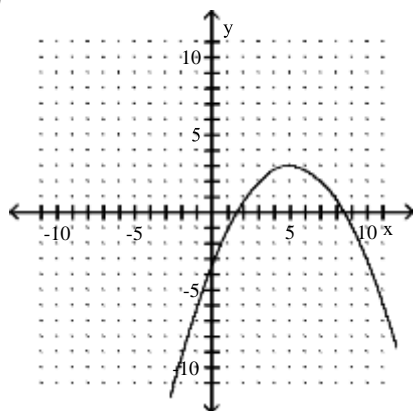

B)

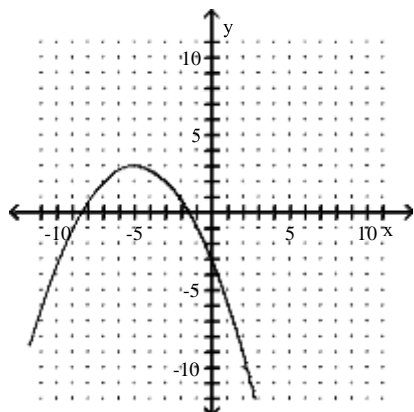

C)

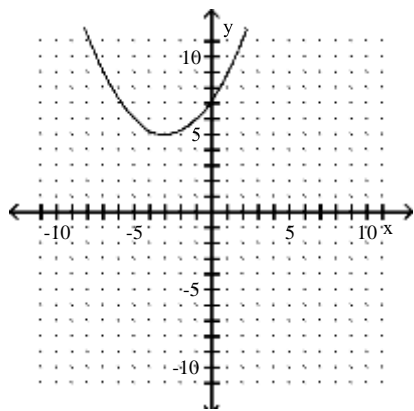

D)

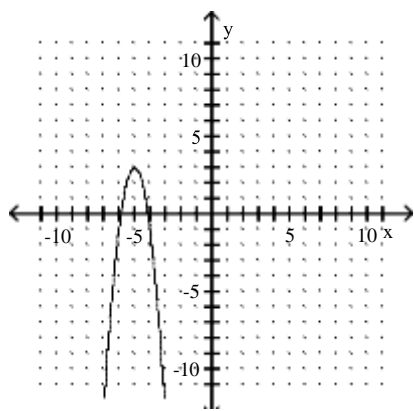

Answer: B

Given the graph of the function $f(x) = -x^3 + 3x$; find a formula for $g(x)$.

264)

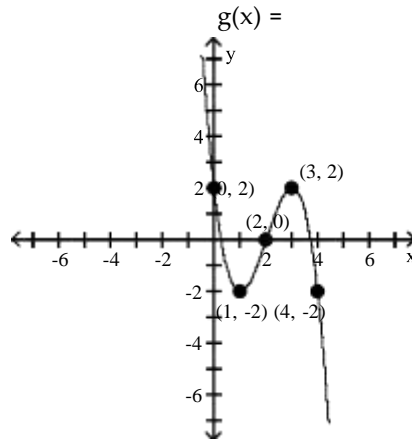
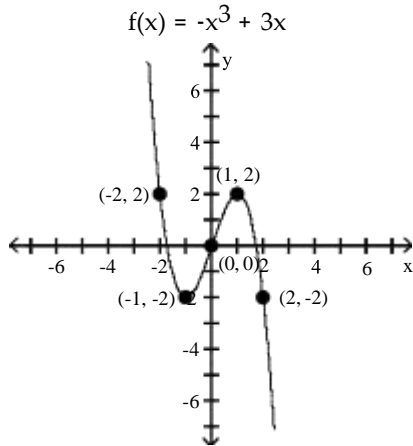

- A) $g(x) = -(x + 2)^3 + 3(x + 2)$
- B) $g(x) = -x^3 + 3x - 2$
- C) $g(x) = -x^3 + 3x + 2$
- D) $g(x) = -(x - 2)^3 + 3(x - 2)$

Answer: D

265)

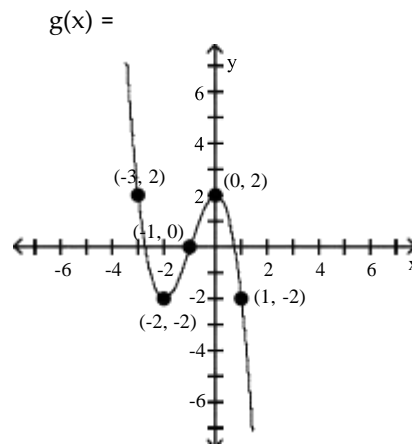
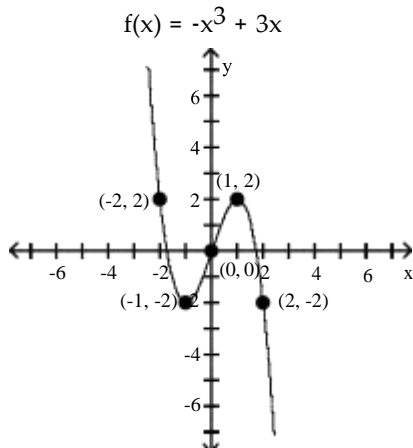

- A) $g(x) = -x^3 + 3x - 1$
- B) $g(x) = -x^3 + 3x + 1$
- C) $g(x) = -(x - 1)^3 + 3(x - 1)$
- D) $g(x) = -(x + 1)^3 + 3(x + 1)$

Answer: D

266)

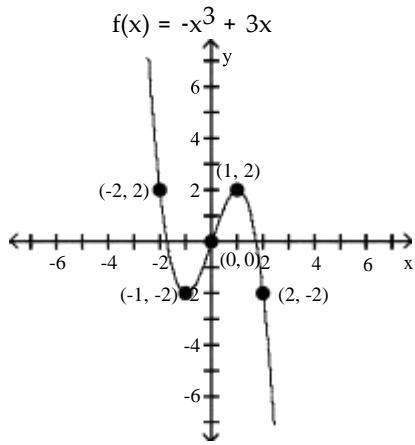

$g(x) =$

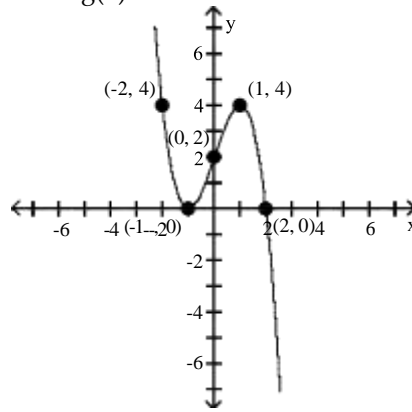

A) $g(x) = -(x - 2)^3 + 3(x - 2)$

B) $g(x) = -x^3 + 3x - 2$

C) $g(x) = -x^3 + 3x + 2$

D) $g(x) = -(x + 2)^3 + 3(x + 2)$

Answer: C

267)

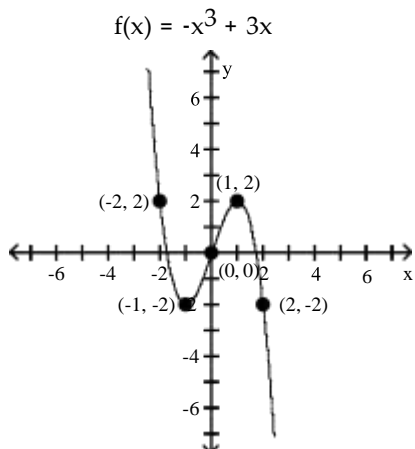

$g(x) =$

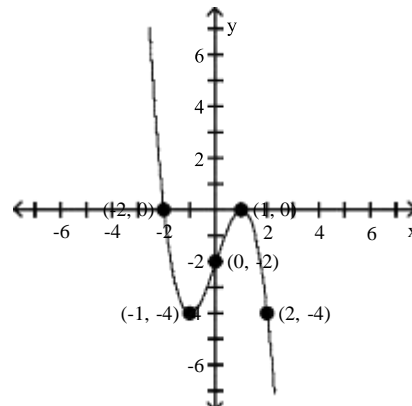

A) $g(x) = -x^3 + 3x - 2$

B) $g(x) = -x^3 + 3x + 2$

C) $g(x) = -(x + 2)^3 + 3(x + 2)$

D) $g(x) = -(x - 2)^3 + 3(x - 2)$

Answer: A

268)

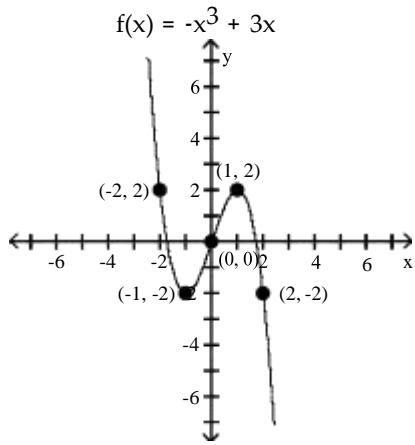

$g(x) =$

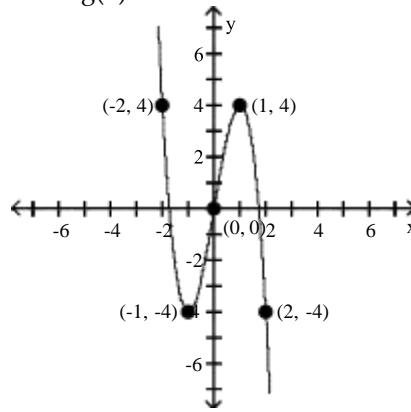

A) $g(x) = -(x + 2)^3 + 3(x + 2)$

B) $g(x) = 2(-x^3 + 3x)$

C) $g(x) = \frac{1}{2}(-x^3 + 3x)$

D) $g(x) = -x^3 + 3x + 2$

Answer: B

269)

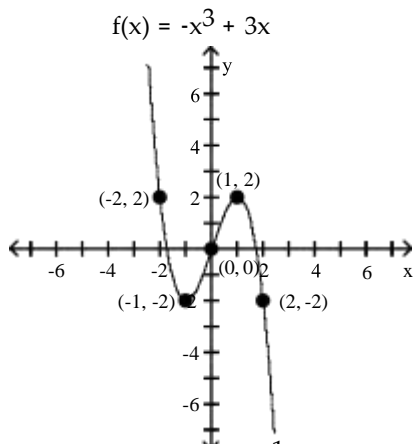

$g(x) =$

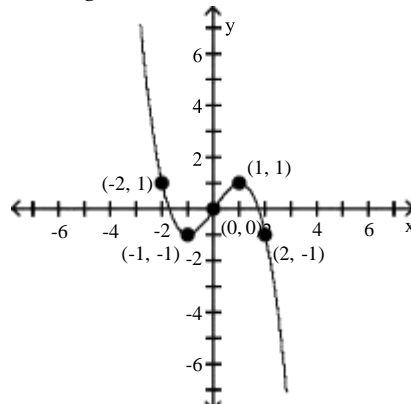

A) $g(x) = -x^3 + 3x + \frac{1}{2}$

B) $g(x) = -x^3 + 3x - \frac{1}{2}$

C) $g(x) = 2(-x^3 + 3x)$

D) $g(x) = \frac{1}{2}(-x^3 + 3x)$

Answer: D

Find an equation of variation for the given situation.

270) y varies directly as z , and $y = 50$ when $z = 400$.

A) $y = 8z$

B) $y = \frac{1}{8}z$

C) $y = -2z$

D) $y = -\frac{1}{2}z$

Answer: B

271) m varies directly as p , and $m = 54$ when $p = 6$.

A) $m = 48p$

B) $m = 60p$

C) $m = \frac{1}{9}p$

D) $m = 9p$

Answer: D

272) p varies directly as q , and $p = 1$ when $q = \frac{1}{15}$.

A) $p = 16q$

B) $p = \frac{1}{15}q$

C) $p = 15q$

D) $p = 14q$

Answer: C

273) r varies directly as s , and $r = 0.0667$ when $s = 1$.

A) $r = 0.0667s$

B) $r = 16s$

C) $r = 14s$

D) $r = 15s$

Answer: A

274) y varies directly as x , and $y = 0.9$ when $x = 0.7$.

A) $y = 0.2x$

B) $y = \frac{9}{7}x$

C) $y = 1.6x$

D) $y = \frac{7}{9}x$

Answer: B

275) y varies inversely as x, and y = 12 when x = 6

- A) $y = \frac{x}{72}$
B) $y = 72x$
C) $y = \frac{72}{x}$
D) $y = \frac{1}{72x}$

Answer: C

276) y varies inversely as x, and y = 6 when x = 14

- A) $y = \frac{x}{84}$
B) $y = \frac{84}{x}$
C) $y = \frac{1}{84x}$
D) $y = 84x$

Answer: B

277) y varies inversely as x and y = 80 when $x = \frac{1}{8}$

- A) $y = \frac{2}{x}$
B) $y = \frac{10}{x}$
C) $y = \frac{8}{x}$
D) $y = \frac{18}{x}$

Answer: B

278) y varies inversely as x and y = 0.9 when x = 0.7

- A) $y = 1.29x$
B) $y = \frac{1.29}{x}$
C) $y = \frac{0.63}{x}$
D) $y = \frac{1.6}{x}$

Answer: C

279) y varies inversely as x and $y = 5.75$ when $x = 0.56$

A) $y = \frac{3.62}{x}$

B) $y = \frac{3.22}{x}$

C) $y = \frac{10.27}{x}$

D) $y = 10.27x$

Answer: B

280) y varies inversely as x and $y = 0.875$ when $x = 24$

A) $y = 21x$

B) $y = \frac{21}{x}$

C) $y = \frac{24}{x}$

D) $y = \frac{22}{x}$

Answer: B

Solve.

281) The distance D that a spring is stretched by a hanging object varies directly as the weight W of the object. If a 17-kg object stretches a spring 75 cm, how far will a 30-kg weight stretch the spring?

A) 122 cm

B) 4.41176471 cm

C) 6.8 cm

D) 132.35 cm

Answer: D

282) The number G of gears a machine can make varies directly as the time T it operates. If it can make 3702 gears in 6 hours, how many gears can it make in 4 hours?

A) 2468 gears

B) 617 gears

C) 3712 gears

D) 0.0065 gears

Answer: A

283) According to Ohm's law, the electric current I , in amperes, in a circuit varies directly as the voltage V . When 7 volts are applied, the current is 3 amperes. What is the current when 26 volts are applied?

A) 11.14 amp

B) 2.33 amp

C) 60.6666667 amp

D) 36 amp

Answer: A

- 284) The weight W of an object on the Moon varies directly as the weight E on earth. A person who weighs 109 lb on earth weighs 21.8 lb on the Moon. How much would a 166-lb person weigh on the Moon?
- A) 33.2 lb
 - B) 296.8 lb
 - C) 0.2 lb
 - D) 830 lb

Answer: A

- 285) The time T necessary to make an enlargement of a photo negative varies directly as the area A of the enlargement. If 80 seconds are required to make a 5-by-4 enlargement, find the time required for a 6-by-5 enlargement.
- A) 150 sec
 - B) 90 sec
 - C) 180 sec
 - D) 120 sec

Answer: D

- 286) The weight of a liquid varies directly as its volume V . If the weight of the liquid in a cubical container 3 cm on a side is 54 g, find the weight of the liquid in a cubical container 4 cm on a side.
- A) 64 g
 - B) 8 g
 - C) 52 g
 - D) 128 g

Answer: D

Solve the problem.

- 287) The pitch P of a musical tone varies inversely as its wavelength W . One tone has a pitch of 251 vibrations per second and a wavelength of 4 ft. Find the wavelength of another tone that has a pitch of 378 vibrations per second.
- A) 23,719.5 ft
 - B) 2.7 ft
 - C) 0.000042 ft
 - D) 0.38 ft

Answer: B

- 288) The current I in an electrical conductor varies inversely as the resistance R of the conductor. The current is 2 amperes when the resistance is 355 ohms. What is the current when the resistance is 570 ohms?
- A) 0.8 amp
 - B) 0.31 amp
 - C) 3.2 amp
 - D) 1.2 amp

Answer: D

- 289) The number of miles per gallon of gasoline that a vehicle averages varies inversely as the average speed the car travels. A vehicle gets 16 miles per gallon at 53 mph. How many miles per gallon will it get at 37 mph?
- A) 11.2 mpg
 - B) 22.9 mpg
 - C) 0.09 mpg
 - D) 0.04 mpg

Answer: B

290) The amount of tread left on a tire varies inversely as the number of miles the tire has traveled. A tire that has traveled 67,000 miles has $\frac{1}{2}$ inches of tread left. How much tread will be left on a tire that has traveled 95,000 miles?

- A) $\frac{1}{134000}$ in.
- B) 134,000 in.
- C) $\frac{67}{190}$ in.
- D) $\frac{190}{67}$ in.

Answer: C

291) The weight that a horizontal beam can support varies inversely as the length of the beam. Suppose that a 10-m beam can support 720 kg. How many kilograms can a 2-m beam support?

- A) 0.0278 kg
- B) 0.0003 kg
- C) 3600 kg
- D) 36 kg

Answer: C

292) The time it takes to complete a certain job varies inversely as the number of people working on that job. If it takes 32 hours for 7 carpenters to frame a house, then how long will it take 48 carpenters to do the same job?

- A) 40 hr
- B) 4.7 hr
- C) 10.5 hr
- D) 48 hr

Answer: B

293) The volume V of a gas at constant temperature varies inversely as the pressure P on it. The volume of a gas is 200 cm^3 under a pressure of 22 kg/cm^2 . What will be its volume under a pressure of 40 kg/cm^2 ?

- A) 400 cm^3
- B) 364 cm^3
- C) 110 cm^3
- D) 121 cm^3

Answer: C

294) The speed of a vehicle is inversely proportional to the time it takes to travel a fixed distance. If a vehicle travels a fixed distance at 60 miles per hour in 35 minutes, how fast must it travel to cover the same distance in 50 minutes?

- A) $\frac{175}{6}$ mph
- B) 42 mph
- C) $\frac{600}{7}$ mph
- D) $\frac{7}{600}$ mph

Answer: B

Find an equation of variation for the given situation.

295) y varies inversely as the square of x , and $y = 3$ when $x = 6$

A) $y = \frac{108}{x^2}$

B) $y = 18x$

C) $y = 18x^2$

D) $y = \frac{106}{x^2}$

Answer: A

296) y varies inversely as the square of x , and $y = 0.17$ when $x = 0.8$

A) $y = .57x^2$

B) $y = \frac{0.136}{x^2}$

C) $y = \frac{0.136}{x}$

D) $y = \frac{0.1088}{x^2}$

Answer: D

297) s varies directly as the square of t , and $s = 147$ when $t = 7$.

A) $s = \frac{1}{21}t^2$

B) $s = \frac{1}{3}t^2$

C) $s = 21t^2$

D) $s = 3t^2$

Answer: D

298) y varies directly as the square of x , and $y = 28.35$ when $x = 9$.

A) $y = 0.4x^2$

B) $y = 0.39\sqrt{x}$

C) $y = 0.35x^2$

D) $y = 1.92x^2$

Answer: C

299) y varies jointly as x and z , and $y = 225$ when $x = 9$ and $z = 5$

A) $y = 5xz$

B) $y = 7xz$

C) $y = 25x$

D) $y = \frac{225}{xz}$

Answer: A

300) y varies jointly as x and the square of z, and y = 160 when x = 8 and z = 2

A) $y = 6xz^2$

B) $y = \frac{80}{x\sqrt{z}}$

C) $y = 5xz^2$

D) $y = 10xz$

Answer: C

301) y varies jointly as x and z, and y = 111.51 when x = 5.9 and z = 9

A) $y = 0.21xz$

B) $y = 5.1xz$

C) $y = 2.1xz$

D) $y = \frac{2.1}{xz}$

Answer: C

302) y varies jointly as x and the square of z, and y = 183 when x = 0.6 and z = 5

A) $y = 14.4xz^2$

B) $y = 12.2xz^2$

C) $y = 7.32x^2z^2$

D) $y = 12.7x\sqrt{z}$

Answer: B

303) y varies directly as x and inversely as z, and y = 6 when x = 9 and z = 12.

A) $y = \frac{8x}{z}$

B) $y = \frac{6x}{z}$

C) $y = 8xz$

D) $y = 6xz$

Answer: A

304) y varies jointly as x and z and inversely as w, and $y = \frac{24}{5}$ when x = 2, z = 3, and w = 5.

A) $y = \frac{4xz}{w}$

B) $y = \frac{24xz}{5w}$

C) $y = \frac{24}{5}xzw$

D) $y = 4xzw$

Answer: A

305) y varies jointly as x and the square of z and inversely as w , and $y = \frac{96}{7}$ when $x = 3$, $z = 2$, and $w = 7$.

A) $y = \frac{16xz^2}{w}$

B) $y = \frac{8xz}{w}$

C) $y = \frac{16xz}{w}$

D) $y = \frac{8xz^2}{w}$

Answer: D

306) y varies directly as x and inversely as z , and $y = 8$ when $x = 2$ and $z = 8$.

A) $y = \frac{36x}{z}$

B) $y = \frac{31z}{x}$

C) $y = \frac{32x}{z}$

D) $y = 35xz$

Answer: C

307) y varies directly as x and inversely as z , and $y = 5.2$ when $x = 2$ and $z = 1.8$.

A) $y = \frac{4.68x}{z}$

B) $y = \frac{x}{z}$

C) $y = 8.36xz$

D) $y = \frac{12.25x}{z}$

Answer: A

308) y varies jointly as x and w and inversely as z , and $y = \frac{9}{2}$ when $x = 2$, $w = 5$, and $z = 20$.

A) $y = 4xwz$

B) $y = \frac{9xw}{z}$

C) $y = \frac{6z}{xw}$

D) $y = \frac{6xw}{z^2}$

Answer: B

309) y varies jointly as x and p and inversely as the square of s , and $y = \frac{7}{2}$ when $x = 1$, $p = 7$, and $s = 6$.

A) $y = \frac{22xp^2}{s}$

B) $y = 11xps^2$

C) $y = \frac{108x^2p}{s^2}$

D) $y = \frac{18xp}{s^2}$

Answer: D

310) y varies jointly as x and z and inversely as the product of w and p , and $y = \frac{6}{5}$ when $x = 1$, $z = 6$, $w = 5$ and $p = 2$.

A) $y = 13pwxz$

B) $y = \frac{12xz}{wp}$

C) $y = \frac{5wp}{xz}$

D) $y = \frac{2xz}{wp}$

Answer: D

Solve the problem.

311) The distance an object falls when dropped from a tower varies directly as the square of the time it falls. If the object falls 144 feet in 3 seconds, how far will it fall in 5 seconds?

A) 80 ft

B) 400 ft

C) 450 ft

D) 350 ft

Answer: B

312) The distance it takes to stop a car varies directly as the square of the speed of the car. If it takes 112 feet for a car traveling at 40 miles per hour to stop, what distance is required for a speed of 52 miles per hour?

A) 189.28 ft

B) 189.62 ft

C) 162.24 ft

D) 201.58 ft

Answer: A

313) The area of a circle varies directly as the square of the radius of the circle. If a circle with a radius of 5 inches has an area of 78.5 square inches, what is the area of a circle with a radius of 18 inches?

A) 113.04 in²

B) 56.52 in²

C) 1019.76 in²

D) 1017.36 in²

Answer: D

- 314) The intensity I of light varies inversely as the square of the distance D from the source. If the intensity of illumination on a screen 5 ft from a light is 3 foot-candles, find the intensity on a screen 15 ft from the light.
- A) $\frac{1}{3}$ foot-candle
 - B) $\frac{3}{5}$ foot-candle
 - C) $1\frac{1}{3}$ foot-candles
 - D) 2 foot-candles

Answer: A

- 315) The weight of a body above the surface of the earth varies inversely as the square of its distance from the center of the earth. What is the effect on the weight when the distance is multiplied by 4?
- A) The weight is divided by 4 .
 - B) The weight is multiplied by 4 .
 - C) The weight is multiplied by 16 .
 - D) The weight is divided by 16 .

Answer: D

- 316) The gravitational attraction A between two masses varies inversely as the square of the distance between them. The force of attraction is 9 lb when the masses are 2 ft apart, what is the attraction when the masses are 6 ft apart?
- A) 2 lb
 - B) 3 lb
 - C) 4 lb
 - D) 1 lb

Answer: D

- 317) The weight of a person on or above the surface of the earth varies inversely as the square of the distance the person is from the center of the earth. If a person weighs 180 pounds on the surface of the earth and the radius of the earth is 3900 miles, what will the person weigh if he or she is 500 miles above the earth's surface? Round your answer to the nearest tenth of a pound.
- A) 140.92 lb
 - B) 141.42 lb
 - C) 142.82 lb
 - D) 141.82 lb

Answer: B

- 318) The intensity of light from a light source varies inversely as the square of the distance from the source. Suppose the intensity is 40 foot-candles at a distance of 10 feet. What will the intensity be at a distance of 22 feet? Round your answer to the tenths place.
- A) 8.5 foot-candles
 - B) 8.3 foot-candles
 - C) 8.0 foot-candles
 - D) 7.7 foot-candles

Answer: B

- 319) The intensity of a radio signal from the radio station varies inversely as the square of the distance from the station. Suppose the the intensity is 8000 units at a distance of 2 miles. What will the intensity be at a distance of 11 miles? Round your answer to the nearest unit.
- A) 228 units
 - B) 264 units
 - C) 290 units
 - D) 247 units

Answer: B

- 320) The volume V of a given mass of gas varies directly as the temperature T and inversely as the pressure P . If $V = 598.0 \text{ in.}^3$ when $T = 460^\circ$ and $P = 10 \text{ lb/in.}^2$, what is the volume when $T = 230^\circ$ and $P = 15 \text{ lb/in.}^2$?
- A) 199.3 in.^3
 - B) 159.3 in.^3
 - C) 169.3 in.^3
 - D) 239.3 in.^3

Answer: A

- 321) At a fixed temperature, the resistance R of a wire varies directly as the length l and inversely as the square of its diameter d . If the resistance is 1.25 ohm when the diameter is 1 mm and the length is 250 cm, what is the resistance when the diameter is 2 mm and the length is 720 cm?
- A) 180 ohm
 - B) 1.8 ohm
 - C) 0.9 ohm
 - D) 225 ohm

Answer: C

- 322) Wind resistance or atmospheric drag tends to slow down moving objects. Atmospheric drag varies jointly as an object's surface area A and velocity v . If a car traveling at a speed of 40 mph with a surface area of 38 ft^2 experiences a drag of 228 N (Newtons), how fast must a car with 37 ft^2 of surface area travel in order to experience a drag force of 305.25 N?
- A) 60 mph
 - B) 52 mph
 - C) 57 mph
 - D) 55 mph

Answer: D

- 323) The cost of stainless steel tubing varies jointly as the length and the diameter of the tubing. If a 5 foot length with diameter 2 inches costs \$48.00 , how much will a 7 foot length with diameter 5 inches cost?
- A) \$173.57
 - B) \$165.60
 - C) \$168.00
 - D) \$173.30

Answer: C

- 324) The resistance of a wire varies directly as the length of the wire and inversely as the square of the diameter of the wire. A 20 foot length of wire with a diameter of 0.1 inch has a resistance of 3 ohms. What would the resistance be for a 44 foot length, with diameter 0.01 inch, of the same kind of wire ?
- A) 653 ohms
 - B) 660 ohms
 - C) 672 ohms
 - D) 657.5 ohms

Answer: B

- 325) The force needed to keep a car from skidding on a curve varies jointly as the weight of the car and the square of the car's speed, and inversely as the radius of the curve. If a force of 3600 pounds is needed to keep an 1800 pound car traveling at 20 mph from skidding on a curve of radius 600 feet, what force would be required to keep the same car from skidding on a curve of radius 620 feet at 40 mph? Round your answer to the nearest pound of force?
- A) 13,803 lb
 - B) 14,505 lb
 - C) 13,935 lb
 - D) 13,967 lb

Answer: C

- 326) The volume of wood in a tree varies jointly as the height of the tree and the square of the distance around the tree trunk. If the volume of wood is 15.84 cubic feet when the height is 22 feet and the distance around the trunk is 3 feet, what is the volume of wood obtained from a tree that is 28 feet tall having a measurement of 6 feet around the trunk?
- A) 89.64 ft³
 - B) 84.64 ft³
 - C) 72.64 ft³
 - D) 80.64 ft³

Answer: D

1. Determine the intervals on which the function is:
 a) increasing,
 b) decreasing, and
 c) constant.

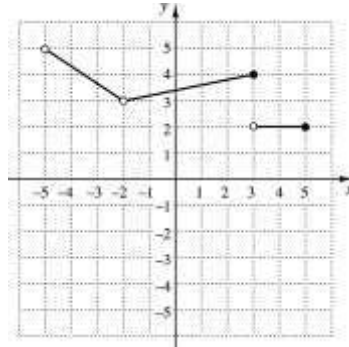

ANSWERS

1. a) _____
 b) _____
 c) _____

2. Graph the function $f(x) = 3 \cdot x^2$. Estimate the intervals on which the function is increasing or decreasing, and estimate any relative maxima or minima.

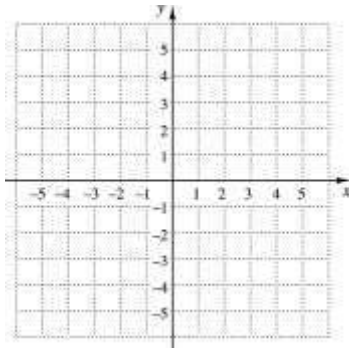

2. See graph.

3. Use a graphing calculator to find the intervals on which the function $f(x) = x^3 - 2x^2$ is increasing or decreasing, and find any relative maxima or minima.

3. _____

4. The length of a rectangular board game is $2\frac{1}{2}$ times the width. If

the board game is w cm wide, express the perimeter as a function of the width.

4. _____

5. Graph:

$$f(x) = \begin{cases} |x|, & \text{for } x \geq 2, \\ x^2, & \text{for } 2 > x > 1, \\ 3x, & \text{for } x \leq 1. \end{cases}$$

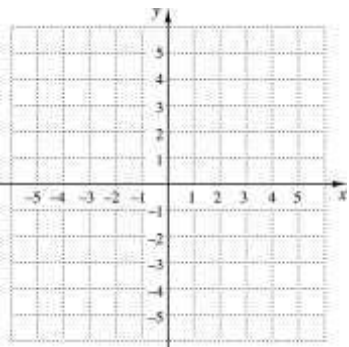

5. See graph.

6. For the function in Exercise 5, find $f(-3)$, $f\left(\frac{3}{4}\right)$, and $f(8)$.

6. _____

CHAPTER 2

NAME _____

TEST FORM A

CLASS _____ **SCORE** _____ **GRADE** _____

TEST FORM A

ANSWERS

Given that $f(x) = x^2 + 2x + 4$ and $g(x) = 9 - x$, find each of the following, if it exists.

7. _____

8. _____

9. _____

7. $(f+g)(5)$

8. $(f-g)(8)$

9. $(fg)(-7)$

10. $(f/g)(0)$

10. _____

For $f(x) = 2x - 1$ and $g(x) = x$, find each of the following.

11. _____

11. The domain of f

12. The domain of fg

12. _____

13. The domain of $f \cdot g$

14. The domain of $f \cdot g$

13. _____

14. _____

15. The domain of fg

16. The domain of f/g

15. _____

17. $f \cdot g^{-1}(x)$

18. $f - g^{-1}(x)$

16. _____

19. $(fg)^{-1}(x)$

20. $(f/g)^{-1}(x)$

17. _____

For each function, construct and simplify the different quotient.

18. _____

$\frac{\quad}{3}$

19. _____

21. $f(x) = \frac{x+5}{4}$

22. $f(x) = 6 - x^2$

20. _____

Given that $f(x) = 2x + 1$, $g(x) = x + 3$, and $h(x) = x^2 - 3x + 4$, find each of the following.

21. _____

22. _____

23. $(f \circ g)(-2)$

24. $(g \circ h)(6)$

23. _____

25. $(h \circ f)(3)$

26. $(f \circ f)(x)$

24. _____

25. _____

27. _____

26. _____

28. _____

For $f(x) = x^2$ and $g(x) = x - 3$:

CHAPTER 2

TEST FORM A

27. Find $(f \circ g)(x)$ and $(g \circ f)(x)$.

28. Find the domain of $(f \circ g)(x)$ and $(g \circ f)(x)$.

Copyright ©2017 Pearson Education, Inc.

$\sqrt{\quad}$

$\cdot \quad \cdot \quad \cdot \quad \sqrt{\quad} \quad \cdot$

—

$\sqrt{\quad}$

TEST FORM A

29. Find $f(x)$ and $g(x)$ such that $h(x) = (f \circ g)(x) = (3 - x^2)^4$.
30. Determine whether the graph of $y = x^4 - 2x^2$ is symmetric with respect to the x -axis, the y -axis, and the origin.
31. Test whether the function $f(x) = \frac{4x}{x-2}$ is even, odd, or neither even nor odd. Show your work.
32. Write an equation for a function that has the shape of $y = \sqrt{x^2}$, but shifted left 5 units and down 3 units.
33. Write an equation for a function that has the shape of $y = x$, but shifted right 2 units and up 1 unit.

34. The graph of a function $y = f(x)$ is shown below. No formula for f is given. Make a graph of $y = f(-x)$.

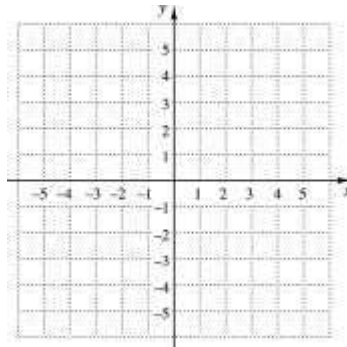
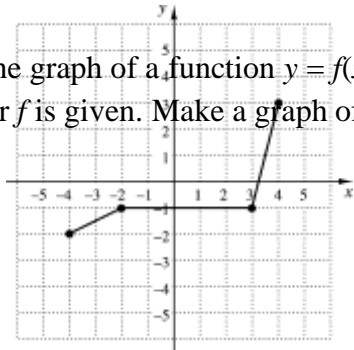

35. Find an equation of variation in which y varies inversely as x , and $y = 15$ when $x = 0.5$.
36. Find an equation of variation in which y varies directly as x , and $y = 1.5$ when $x = 0.3$.
37. Find an equation of variation where y varies jointly as x and z and inversely as the square of w , and $y = 240$ when $x = 3$, $z = 5$, and $w = \frac{1}{2}$.

38. The current I in an electrical conductor varies inversely as the

ANSWERS

29. _____

30. _____

31. _____

32. _____

33. _____

34. See graph.

35. _____

36. _____

37. _____

38. _____

resistance R of the conductor. Suppose I is 0.2 ampere when the resistance is 200 ohms. Find the current when the resistance is

CHAPTER 2

Copyright ©2017 Pearson Education, Inc.

39

TEST FORM A

TEST FORM A

39. The graph of the function f is shown to the right.

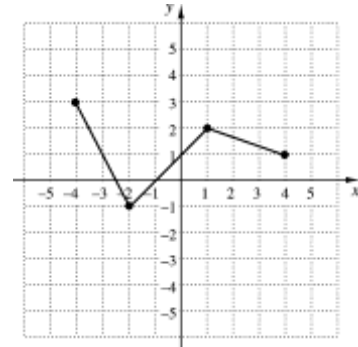

ANSWERS

39. _____

Which of the following represents the graph of $g(x) = -2f(x) + 3$?

A.

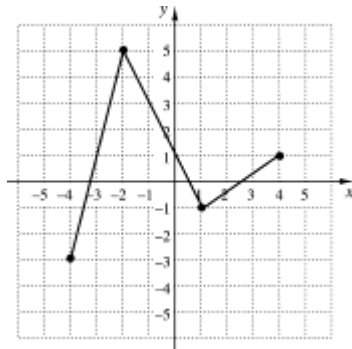

B.

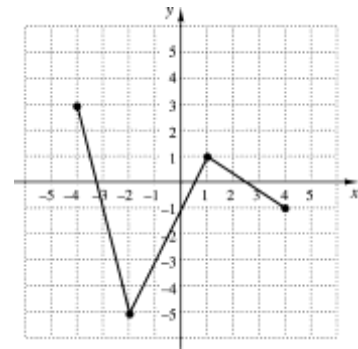

40. _____

C.

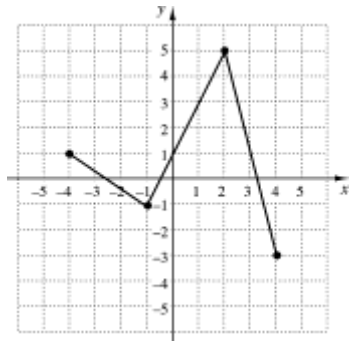

D.

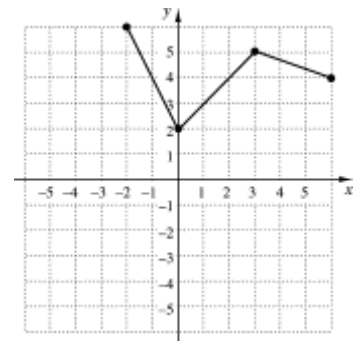

40. If $(-10, 10)$ is a point in the graph of $y = f(x)$, what point do you know is on the graph of $y = f^{-1}(x)$?

$(10, -2)$

1. Determine the intervals on which the function is:
- increasing,
 - decreasing, and
 - constant.

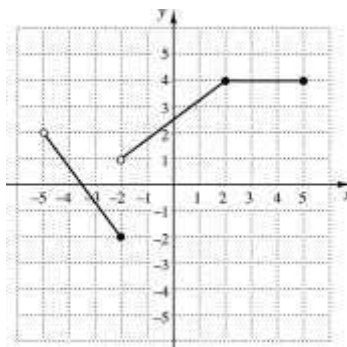

ANSWERS

1. a) _____
 b) _____
 c) _____

2. Graph the function $f(x) = x^2 - 4$. Estimate the intervals on which the function is increasing or decreasing, and estimate any relative maxima or minima.

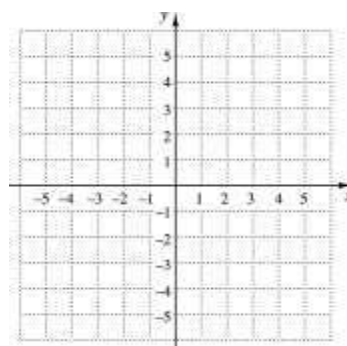

2. See graph.

3. Use a graphing calculator to find the intervals on which the function $f(x) = x^3 + 5x^2$ is increasing or decreasing, and find any relative maxima or minima.

3. _____

4. The length of a rectangular table cloth is 2 ft more than the width. If the table cloth is w feet wide, express the perimeter as a function of the width.

4. _____

5. Graph:

$$f(x) = \begin{cases} x + 2, & \text{for } x < -2, \\ x^2 - 3, & \text{for } -2 \leq x \leq 2, \\ \sqrt{x}, & \text{for } x > 2. \end{cases}$$

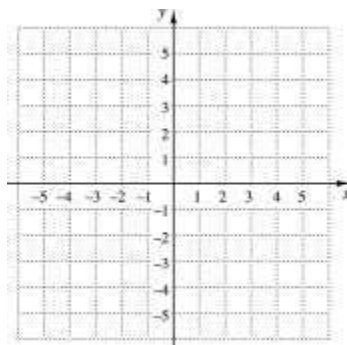

5. See graph.

6. For the function in Exercise 5, find $f(-4)$, $f\left(\frac{1}{2}\right)$, and $f(9)$.

6. _____

TEST FORM B

ANSWERS

Given that $f(x) = x^2 - 2x + 1$ and $g(x) = \frac{1}{\sqrt{x+6}}$, find each of the following if it exists.

7. _____

8. _____

9. _____

10. _____

11. _____

12. _____

13. _____

14. _____

15. _____

16. _____

17. _____

18. _____

19. _____

20. _____

21. _____

22. _____

23. _____

24. _____

25. _____

26. _____

27. _____

7. $(f+g)(-1)$

8. $(f-g)(-2)$

9. $(fg)(10)$

10. $(g/f)(3)$

For $f(x) = -2x + 4$ and $g(x) = \frac{1}{x}$, find each of the following.

11. The domain of f

12. The domain of g

13. The domain of $f \cdot g$

14. The domain of $f \cdot g$

15. The domain of fg

16. The domain of g/f

17. $(f+g)(x)$

18. $(f-g)(x)$

19. $(fg)(x)$

20. $(f/g)(x)$

For each function, construct and simplify the different quotient.

21. $f(x) = 1 - 5x$

22. $f(x) = 5x^2 + 2$

Given that $f(x) = x^2 - 2x + 1$, $g(x) = 2x + 3$, and $h(x) = x^2 - 4$, find each of the following.

23. $(f \circ g)(-1)$

24. $(g \circ h)(4)$

25. $(h \circ f)(1)$

26. $(g \circ g)(x)$

28. _____

$$\sqrt{x+2}$$

For $f(x) =$ and
 $g(x) = x - 8$:

27. $(f \circ g)(x)$ and $(g \circ f)(x)$.

28. Find the domain of $(f \circ g)(x)$ and $(g \circ f)(x)$.

CHAPTER 2

TEST FORM B

Copyright ©2017 Pearson Education, Inc.

TEST FORM B

29. Find $f(x)$ and $g(x)$ such that $h(x) = (f \circ g)(x) = \sqrt{x^2 + 2x - 4}$.
30. Determine whether the graph of $y = x^3 - 2x$ is symmetric with respect to the x -axis, the y -axis, and/or the origin.
31. Test whether the function $f(x) = 4x^3 - 2x$ is even, odd, or neither even nor odd. Show your work.
32. Write an equation for a function that has the shape of $y = |x|$, but shifted right 4 units and up 2 units.
33. Write an equation for a function that has the shape of $y = x^3$, but shifted left 3 units and down 2 units.
34. The graph of a function $y = f(x)$ is shown below. No formula for f is given. Make a graph of $y = f(x - 2)$.

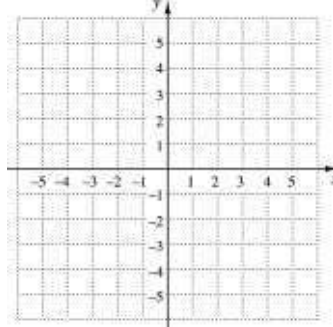
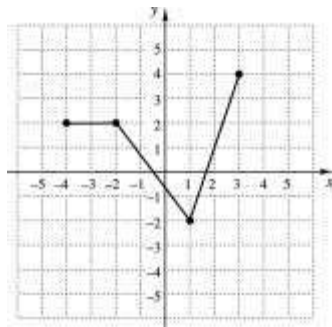

35. Find an equation of variation in which y varies inversely as x , and $y = 0.4$ when $x = 8$.
36. Find an equation of variation in which y varies directly as x , and $y = 0.8$ when $x = 5$.
37. Find an equation of variation where y varies jointly as the square of x and the square of z and inversely as w , and $y = 4$ when $x = 4$, $z = \frac{1}{2}$, and $w = 5$.
38. The volume of a 6-in. tall cone varies directly as the square of the radius. The volume is 14.1 in^3 when the radius is 1.5 in. Find the volume when the radius is 3 in.

ANSWERS

29. _____
30. _____
31. _____
32. _____
33. _____
34. See graph.
35. _____
36. _____
37. _____
38. _____

CHAPTER 2

NAME _____

TEST FORM B

TEST FORM B

ANSWERS

39. _____

39. The graph of the function f is shown to the right.

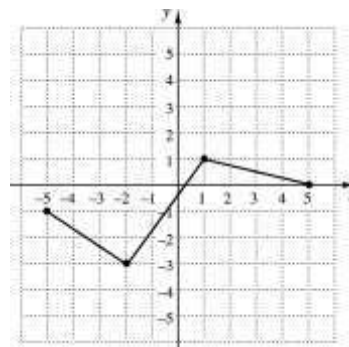

Which of the following represents the graph of $g(x) = -2f(x) - 3$?

A.

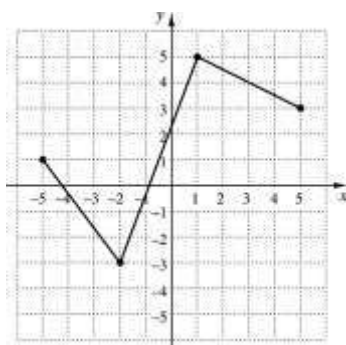

B.

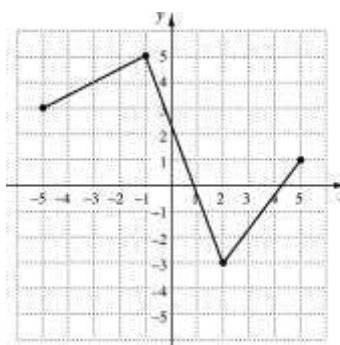

40. _____

C.

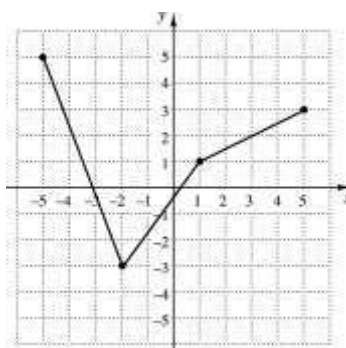

D.

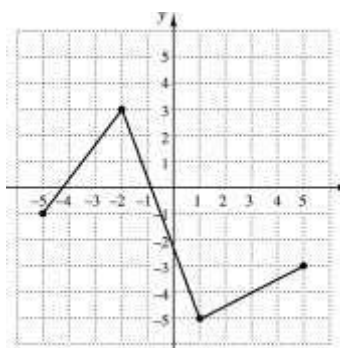

40. If $(-6, 3)$ is a point in the graph of $y = f(x)$, what point do you know is on the graph of $y = f(-3x)$?

1. Determine the intervals on which the function is:
- increasing,
 - decreasing, and
 - constant.

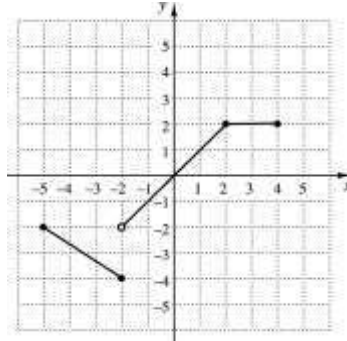

2. Graph the function $f(x) = |x| + 2$:

Estimate the intervals on which the function is increasing or decreasing, and estimate any relative maxima or minima.

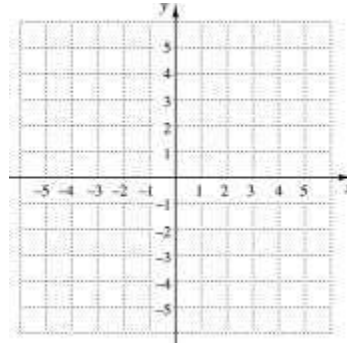

3. Use a graphing calculator to find the intervals on which the function $f(x) = 2x^3 - 5x^2$ is increasing or decreasing, and find any relative maxima or minima.
4. The length of a rectangular picture frame is 10.5 in. greater than the width. If the picture frame is w feet wide, express its area as a function of the width.

5. Graph:

$$f(x) = \begin{cases} -2x, & \text{for } x < -2, \\ -x^2, & \text{for } -2 \leq x \leq 2, \\ 5, & \text{for } x > 2. \end{cases}$$

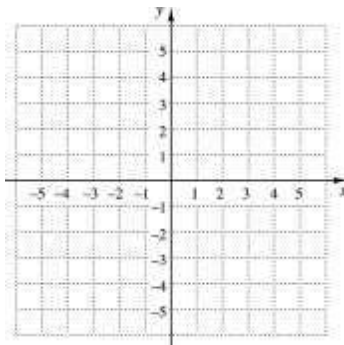

6. For the function in Exercise 5, find $f\left(-\frac{1}{2}\right)$, $f(3)$, and $f(-4)$.

ANSWERS

1. a) _____

b) _____

c) _____

2. See graph.

3. _____

4. _____

5. See graph.

6. _____

TEST FORM C

ANSWERS

Given that $f(x) = x^2 - 3x + 2$ and $g(x) = 4 - x$, find each of the following if it exists.

7. _____

8. _____

9. _____

7. $(f+g)(3)$

8. $(f-g)(4)$

9. $(fg)(-5)$

10. $(f/g)(2)$

10. _____

11. _____

12. _____

13. _____

14. _____

15. _____

16. _____

17. _____

18. _____

19. _____

20. _____

21. _____

22. _____

For $f(x) = x^2$ and $g(x) = \sqrt{2x}$, find each of the following.

11. The domain of f

12. The domain of g

13. The domain of $f+g$

14. The domain of $f-g$

15. The domain of fg

16. The domain of f/g

17. $(f+g)(x)$

18. $(f-g)(x)$

19. $(fg)(x)$

20. $(f/g)(x)$

For each function, construct and simplify the different quotient.

21. $f(x) = 0.1x + 6$

22. $f(x) = x^3 - x$

Given that $f(x) = 4 - x^2$, $g(x) = \frac{1}{2}x + 2$, and $h(x) = x^2 + 6x - 3$, find each of the following.

23. _____

23. $(f \circ g)(2)$

24. $(g \circ h)(4)$

24. _____

25. $(h \circ f)(-1)$

26. $(g \circ g)(x)$

25. _____

For $f(x) = x - 5$ and $g(x) = x + 2$:

26. _____

28. _____

27. _____

27. $(f \circ g)(x)$ and $(g \circ f)(x)$.
CHAPTER 2

28. Find the domain of $(f \circ g)(x)$ and $(g \circ f)(x)$.

NAME _____

TEST FORM C

Copyright ©2017 Pearson Education, Inc.



TEST FORM C

29. Find $f(x)$ and $g(x)$ such that $h(x) = (f \circ g)(x) = \frac{(x-1)^3}{|x+1|}$
30. Determine whether the graph of $y = 3x^6 \cdot 2x^4$ is symmetric with respect to the x -axis, the y -axis, and/or the origin.
31. Test whether the function $f(x) = 5x^3 - 7$ is even, odd, or neither even nor odd. Show your work.
32. Write an equation for a function that has the shape of $y = x^3$, but shifted right 4 units and up 6 units.
33. Write an equation for a function that has the shape of $y = |x|$, but shifted left 3 units and down 1 unit.
34. The graph of a function $y = f(x)$ is shown below. No formula for f is given. Make a graph of $y = f(x-1)$.

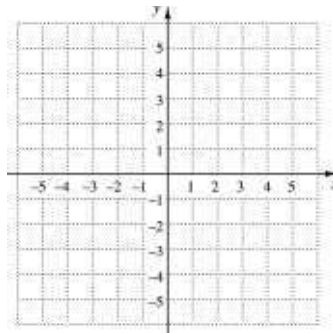
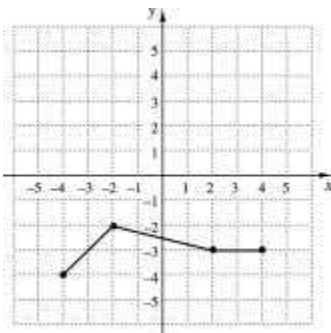

35. Find an equation of variation in which y varies inversely as x , and $y = 1800$ when $x = 150$.
36. Find an equation of variation in which y varies directly as x , and $y = 0.5$ when $x = 1.5$.
37. Find an equation of variation where y varies jointly as x and z and inversely as the square root of w , and $y = 54$ when $x = 4$, $z = 9$, and $w = 4$.
38. The surface area of a balloon varies directly as the square of its radius. The area is 78.5 cm^2 when the radius is 2.5 cm . Find the area when the radius is 3 cm .

ANSWERS

29. _____

30. _____

31. _____

32. _____

33. _____

34. See graph.

35. _____

36. _____

37. _____

38. _____

CHAPTER 2

NAME _____

TEST FORM C

TEST FORM C

ANSWERS

39. _____

39. The graph of the function f is shown to the right.

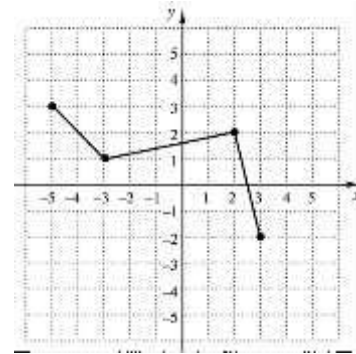

Which of the following represents the graph of $g(x) = -f(x) + 2$?

A.

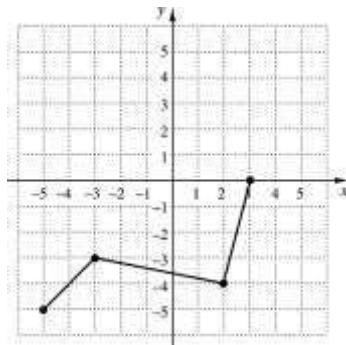

B.

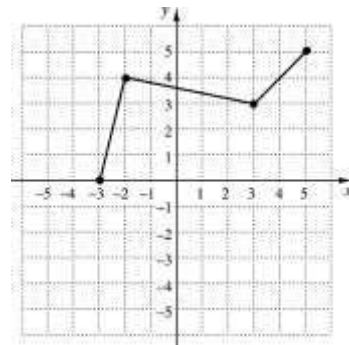

40. _____

C.

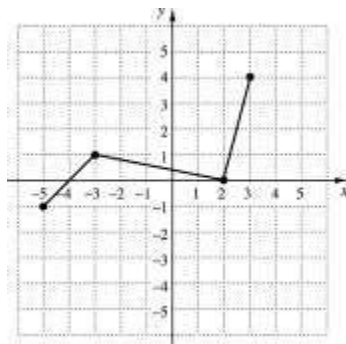

D.

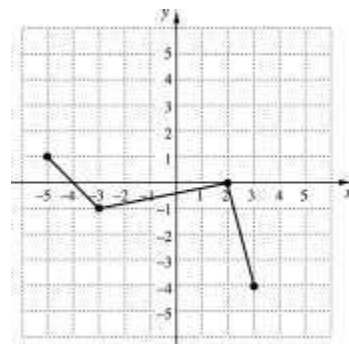

40. If $(4, -6)$ is a point in the graph of $y = f(x)$, what point do you know is on the graph of $y = f(-2x)$?

1. Determine the intervals on which the function is:
- increasing,
 - decreasing, and
 - constant.

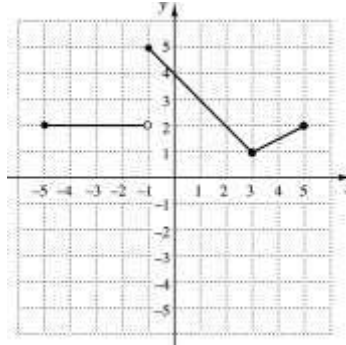

2. Graph the function $f(x) = 5 - |x|$. Estimate the intervals on which the function is increasing or decreasing, and estimate any relative maxima or minima.

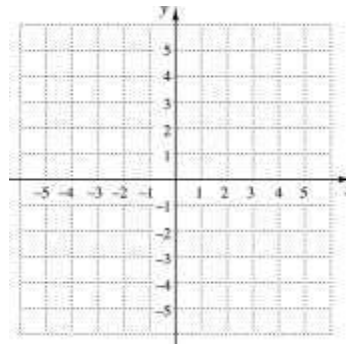

3. Use a graphing calculator to find the intervals on which the function $f(x) = 5x^3 - 6x^2$ is increasing or decreasing, and find any relative maxima or minima.
4. The length of a rectangular parking lot is 40 ft more than the width. If the parking lot is w feet wide, express its area as a function of the width

5. Graph:

$$f(x) = \begin{cases} \sqrt{x+5}, & \text{for } x < -1, \\ x^2, & \text{for } -1 \leq x \leq 2, \\ -|x|, & \text{for } x > 2. \end{cases}$$

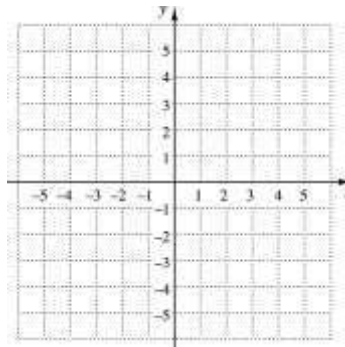

6. For the function in Exercise 5, find $f(-5)$, $f\left(\frac{2}{3}\right)$, and $f(4)$.

ANSWERS

1. a) _____

b) _____

c) _____

2. See graph.

3. _____

4. _____

5. See graph.

6. _____

TEST FORM D

ANSWERS

Given that $f(x) = x^2 + 2x - 8$ and $g(x) = \sqrt{x+4}$, find each of the following if it exists.

7. _____

8. _____

9. _____

10. _____

11. _____

12. _____

13. _____

14. _____

15. _____

16. _____

17. _____

18. _____

19. _____

20. _____

21. _____

22. _____

23. _____

24. _____

25. _____

7. $(f+g)(-3)$

8. $(f-g)(12)$

9. $(fg)(-4)$

10. $(f/g)(5)$

For $f(x) = \frac{1}{x^2}$ and $g(x) = x + 4$, find each of the following.

11. The domain of f

12. The domain of fg

13. The domain of $f \cdot g$

14. The domain of $f \cdot g$

15. The domain of fg

16. The domain of f/g

17. $(f+g)(x)$

18. $(f-g)(x)$

19. $(fg)(x)$

20. $(f/g)(x)$

For each function, construct and simplify the different quotient.

1

21. $f(x) = 14 - \frac{x}{2}$

22. $f(x) = 2x^2 + 6$

Given that $f(x) = x^2 + 2$, $g(x) = 2x - 5$, and $h(x) = 3x^2 + 4x - 2$, find each of the following.

23. $(f \circ g)(1)$

24. $(g \circ h)(-3)$

25. $(h \circ f)(2)$

26. $(g \circ g)(x)$

26. _____ For $f(x) = 3x - 2$ and $g(x) = \sqrt{x}$:

~~CHAPTER 2~~

27. Find $(f \circ g)(x)$ and $(g \circ f)(x)$. NAME _____

~~TEST FORM D~~

28. Find the domain of $(f \circ g)(x)$ and $(g \circ f)(x)$.

TEST FORM D

29. Find $f(x)$ and $g(x)$ such that

$$h(x) = (f \circ g)(x) = (x - 3)^2 + 3(x - 3) - 40.$$

ANSWERS

29. _____

30. Determine whether the graph of $y = \frac{3x}{x^2 - 4}$ is symmetric with

respect to the x -axis, the y -axis, and/or the origin.

30. _____

31. Test whether the function $f(x) = \sqrt{4 - x^2}$ is even, odd, or neither even nor odd. Show your work.

31. _____

32. Write an equation for a function that has the shape of $y = \sqrt{x}$, but shifted right 5 units and down 3 units.

32. _____

33. Write an equation for a function that has the shape of $y = x^2$, but shifted left 2 units and up 4 units.

33. _____

34. The graph of a function $y = f(x)$ is shown below. No formula for f is given. Make a graph of $y = -f(x)$.

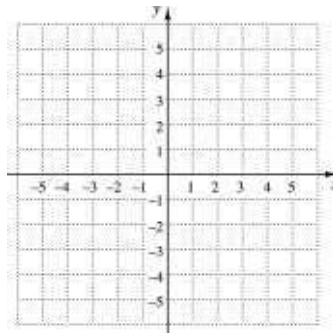
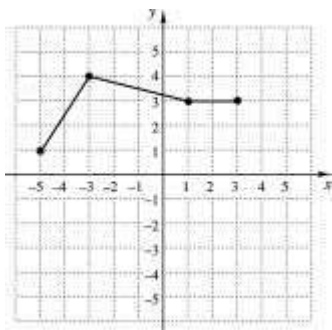

34. See graph.

35. _____

35. Find an equation of variation in which y varies inversely as x , and

$$y = \frac{2}{3} \text{ when } x = 9.$$

36. _____

36. Find an equation of variation in which y varies directly as x , and $y = 14$ when $x = 6$.

intensity at 20 m.

37. Find an equation of variation where y varies jointly as x and the square of z and inversely as w , and $y = 0.05$ when $x = 5$, $z = 0.2$, and $w = 8$.

38. The intensity I of a light from a light bulb varies inversely as the square of the distance d from the bulb. Suppose I is 60 W/m^2 (watts per square meter) when the distance is 5 m. Find the

37. _____

CHAPTER 2

NAME _____
Copyright ©2017 Pearson Education, Inc.

38. _____

TEST FORM D

TEST FORM D

ANSWERS

39. _____

39. The graph of the function f is shown to the right.

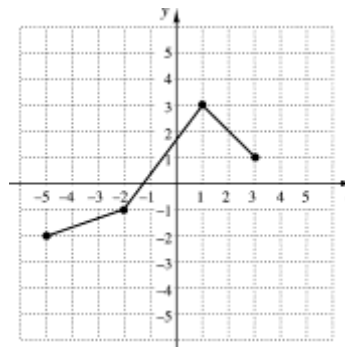

Which of the following represents the graph of $g(x) = -f(x) - 3$?

A.

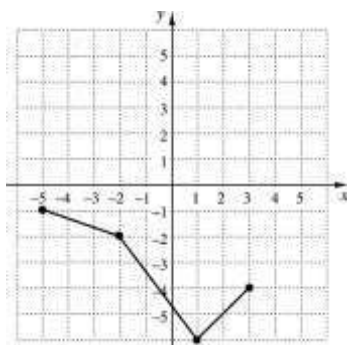

B.

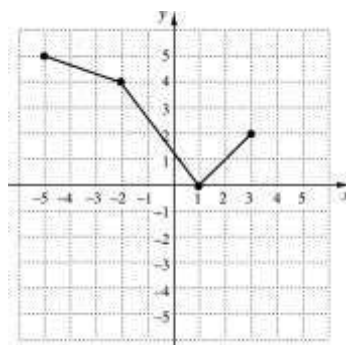

40. _____

C.

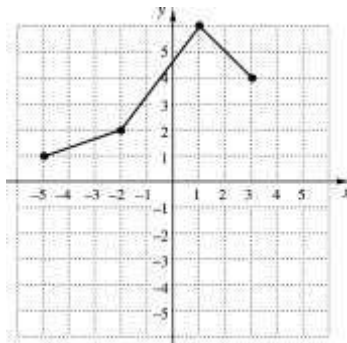

D.

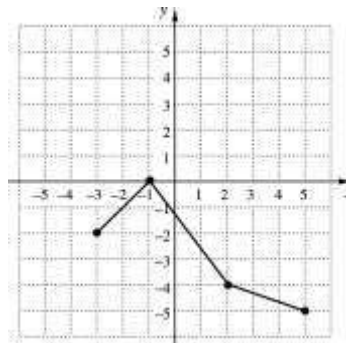

40. If $(-3, 6)$ is a point in the graph of $y = f(x)$, what point do you know is on the graph of $y = f(x + 3)$?

1. Determine on which interval the function is decreasing.

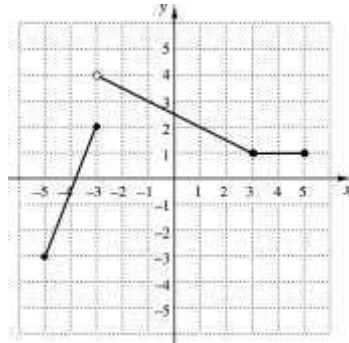

- a) $(-5, -3)$ b) $(-3, 4)$ c) $(4, 1)$ d) $(-3, 3)$
2. The width of a rectangular blanket is 4 less than twice the length l . Express the area of the blanket as a function of l .

- a) $A(l) = 4l - 2l^2$ b) $A(l) = 2l^2 - 4$
 c) $A(l) = 3l - 4$ d) $A(l) = 2l^2 - 4l$

Use the following function for Exercises 3 and 4.

$$f(x) = \begin{cases} 2x^2, & \text{for } x \leq -1, \\ \sqrt{x+3}, & \text{for } -1 < x \leq 6, \\ |x-4|, & \text{for } x > 6. \end{cases}$$

3. Find $f(-1)$.
 a) -2 b) $\sqrt{2}$ c) 2 d) 4
4. Find $f(5)$.
 a) 1 b) 50 c) $\sqrt{5}$ d) $\sqrt{8}$
5. For $f(x) = x^3 + 4x - 5$ and $g(x) = -2x + 5$, find $(g-f)(-1)$.
 a) -17 b) 15 c) 17 d) 9
6. For $f(x) = 3x - 4$ and $g(x) = \sqrt{x}$, find $h(x) = (fg)(x)$.
 a) $h(x) = 3x - 4 + \sqrt{x}$ b) $h(x) = \sqrt{x}(3x - 4)$
 c) $h(x) = 3\sqrt{x} - 4$ d) $h(x) = \sqrt{3x - 4}$

ANSWERS

1. _____

2. _____

3. _____

4. _____

5. _____

6. _____

CHAPTER 2

NAME _____

TEST FORM E

CLASS _____ **SCORE** _____ **GRADE** _____

$$b) x = y^2$$

$$d) y = x - x^3$$

14
CHAPTER 2 _____

14. Which of the following functions is even?

NAME _____

$$a) y = 16 - x^2 \quad b) y = 2x^5$$

$$c) y = 4x - 6$$

$$d) y = \sqrt{x}$$

TEST FORM E

TEST FORM E

15. Write an equation for a function that has the shape of $y = x^2$, but is shifted left 3 units and up 4 units.

- a) $f(x) = (x + 3)^2 + 4$ b) $f(x) = (x - 3)^2 + 4$
 c) $f(x) = (x - 3)^2 - 4$ d) $f(x) = (x + 3)^2 - 4$

16. The graph of $y = f(x)$ is given.

Which graph below represents the graph of $y = f(x) - 1$?

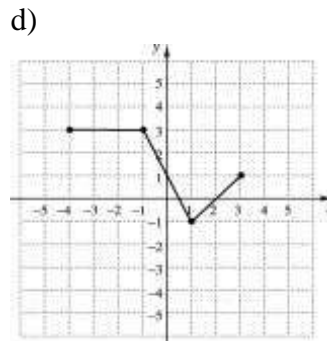
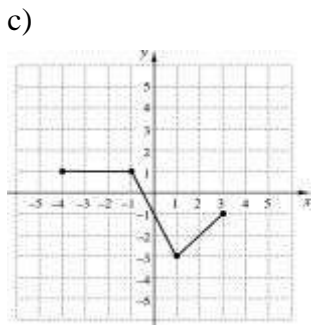
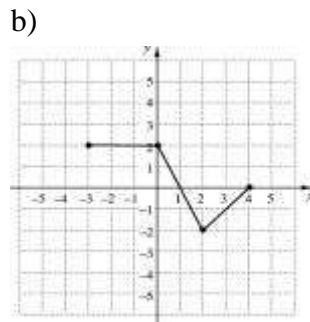
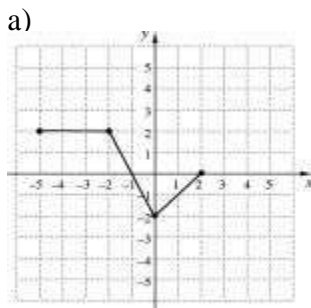
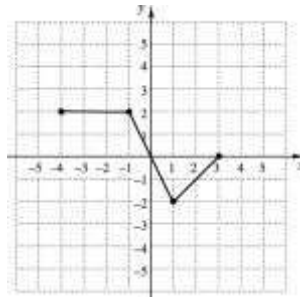

17. Find an equation of variation in which y varies directly as x and

$y = \frac{2}{3}$ and $x = 9$.

- a) $y = \frac{27}{2}x$ b) $y = \frac{2}{27}x$ c) $y = 6x$ d) $y = \frac{6}{x}$

18. If y varies inversely as x and $y = 1.5$ when $x = 8$, find y when $x = 20$.

ANSWERS

15. _____

16. _____

17. _____

a) $\frac{5}{3}$

b) $\frac{15}{4}$

c) $\frac{320}{3}$

d) $\frac{3}{5}$

CHAPTER 2

Copyright ©2017 Pearson Education, Inc. **NAME** _____

55

TEST FORM E

TEST FORM E

ANSWERS

19. _____

19. d varies inversely as w and directly as the square of v . If $d = 400$ when $w = 0.2$ and $v = 4$, find d when $w = 3$ and $v = 9$.

- a) $\frac{20}{3}$ b) 135 c) 5 d) 3375

20. The graph of the function f

is shown to the right.

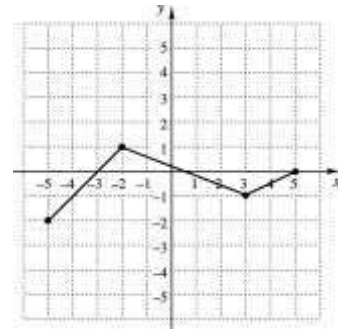

20. _____

Which of the following represents the graph of $g(x) = 2f(x) + 1$?

21. _____

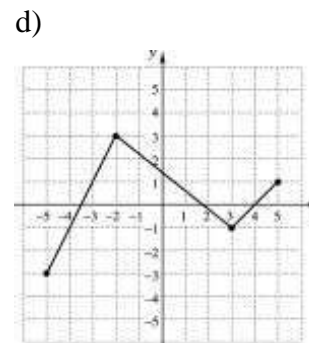
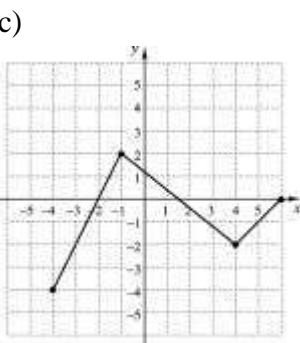
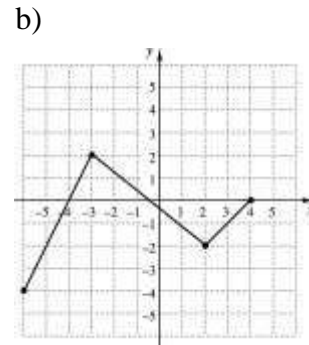
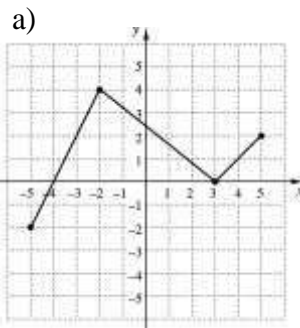

21. If $(-1, -4)$ is a point on the graph of $y = f(x)$, what point do you know is on the graph of $y = f^{-1}(x)$?

- a) $(-1, -2)$ b) $(\frac{1}{2}, -4)$ c) $(-2, -4)$ d) $(\frac{1}{2}, 2)$

CHAPTER 2

NAME _____

TEST FORM F

CLASS _____ SCORE _____ GRADE _____

1. Determine on which interval the function is increasing.

ANSWERS

1. _____

2. _____

- a) $(-2, 4)$ b) $(2, 3)$ c) $(-3, 2)$ d) $(2, 5)$

2. The width of a rectangular blanket is $\frac{2}{3}$ of the length l . Express the area of the blanket as a function of l .

- a) $A(l) = \frac{2}{3}l^2$ b) $A(l) = \frac{3}{2}l^2$ c) $A(l) = \frac{10}{3}l$ d) $A(l) = \frac{5}{3}l^2$

3. _____

Use the following function for Exercises 3 and 4.

$$f(x) = \begin{cases} x^2 - 1, & \text{for } x < 3, \\ x - 6, & \text{for } 3 \leq x < 1, \\ 3x, & \text{for } x \geq 1. \end{cases}$$

4. _____

3. Find $f(-1)$

- a) 2 b) 0 c) 7 d) 5

4. Find $f(2)$

- a) 5 b) 6 c) 1 d) 4

5. For $f(x) = x^3 - 2x + 1$ and $g(x) = -4x + 6$, find $(f - g)(-2)$.

- a) -1 b) -15 c) -25 d) -17

5. _____

6. For $f(x) = x^2 - 5$ and $g(x) = x$, find $h(x) = (fg)(x)$.

- a) $h(x) = x^2 - 5 + x$ b) $h(x) = x - 5$

- c) $h(x) = x^2 - x - 5$ d) $h(x) = x^2 - 5$

6. _____

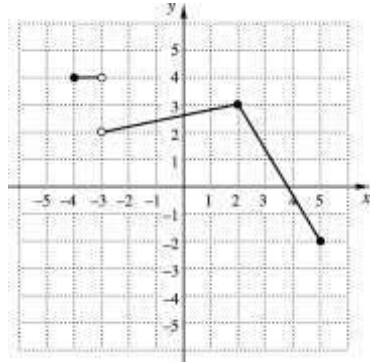

TEST FORM F

ANSWERS

7. _____ 7. For $f(x) = x^2 - 5$ and $g(x) = \sqrt{x}$, find the domain of f/g .
- a) $(-\infty, 0) \cup (0, \infty)$
 b) $[0, \infty)$
 c) $(-\infty, -\sqrt{5}) \cup (-5, 5) \cup (5, \infty)$
 d) $(0, \infty)$
8. _____ 8. Construct and simplify the difference quotient for $f(x) = \frac{1}{2}x + 2$.
- a) 2 b) $\frac{1}{2}h$ c) $\frac{1}{2}$ d) $\frac{1}{2}xh + 2h$
9. _____ 9. Construct and simplify the difference quotient for $f(x) = 2x^2 - 3x + 1$.
- a) $4x + 2h - 3$ b) $4h^2 - 3h$
 c) $2x + h$ d) $4xh + 2h^2 - 3h$
10. _____ 10. For $f(x) = x + 4$ and $g(x) = 2x^2$, find $h(x) = (g \circ f)(x)$.
- a) $h(x) = 2x^2 + 4$ b) $h(x) = 2x^3 + 8x^2$
 c) $h(x) = 2x^2 + 16x + 32$ d) $h(x) = 2x^2 + x + 4$
11. _____ 11. For $g(x) = 2x - 5$, find $h(x) = (g \circ g)(x)$.
- a) $h(x) = 4x - 10$ b) $h(x) = 4x^2 - 20x + 25$
 c) $h(x) = 4x - 5$ d) $h(x) = 4x - 15$
12. _____ 12. For $f(x) = \sqrt{x+2}$ and $g(x) = 3x - 5$, find the domain of $(f \circ g)(x)$.
- a) $[0, \infty)$ b) $[1, \infty)$ c) $(-\infty, \infty)$ d) $[-2, \infty)$
13. _____ 13. Which of the following is symmetric with respect to the origin?
- a) $f(x) = 5 - x^2$ b) $f(x) = x$
 c) $f(x) = 5x^3$ d) $f(x) = \sqrt{x}$

14. _____

14. Which of the following functions is even?

CHAPTER 2

a) $f(x) = 2x + 8$

NAME _____

b) $f(x) = \sqrt{4 - x^2}$

TEST FORM F

c) $f(x) = x^2 + x$

d) $f(x) = \sqrt[4]{x}$

TEST FORM F

15. Write an equation for a function that has the shape of $y = |x|$, but is shifted right 2 units and down 6 units.

- a) $f(x) = |x + 2| - 6$ b) $f(x) = |x - 2| + 6$
 c) $f(x) = |x + 2| + 6$ d) $f(x) = |x - 2| - 6$

16. The graph of $y = f(x)$ is given. Which graph below represents the graph of $y = f(x) - 1$?

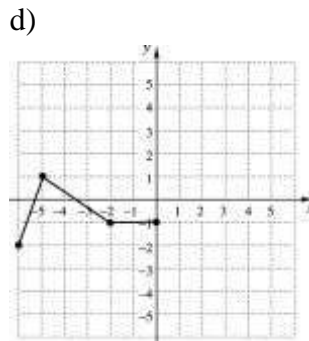
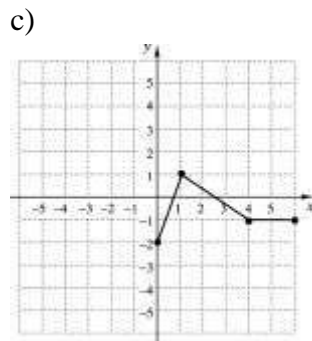
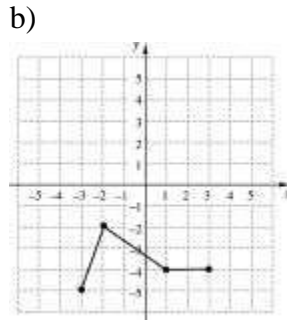
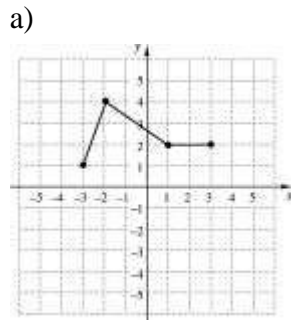
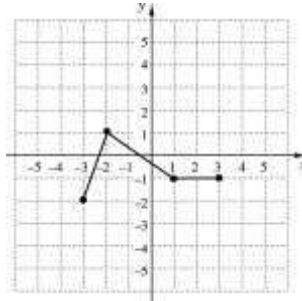

17. Find an equation of variation in which y varies directly as x and $y = 18$ and $x = \frac{1}{3}$.

- a) $y = 54x$ b) $y = \frac{1}{54}x$ c) $y = \frac{6}{x}$ d) $y = 6x$

18. If y varies inversely as x and $y = 4$ when $x = 0.2$, find y when $x = 8$.

ANSWERS

15. _____

16. _____

17. _____

18. _____

a) 160

b) 10

c) 0.1

d) 0.4

Copyright ©2017 Pearson Education, Inc.

59

CHAPTER 2

NAME _____

TEST FORM F

TEST FORM F

ANSWERS

19.19. _____

19. p varies directly as the square of m and inversely as n . If $p = 200$ when $m = 5$ and $n = \frac{1}{2}$, find p when $m = 6$ and $n = 2$.
- a) 72 b) 360 c) 288 d) 4

20.

The graph of the function f is shown to the right.

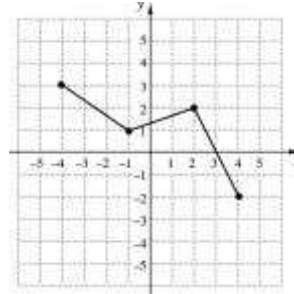

20. _____

Which of the following represents the graph of $g(x) = -f(x) + 2$

a)

b)

21. _____

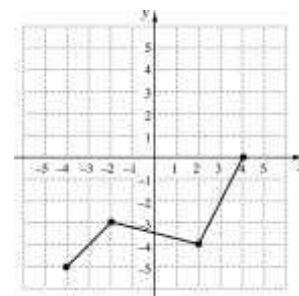
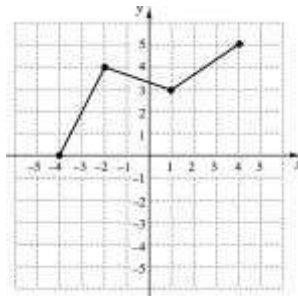

c)

d)

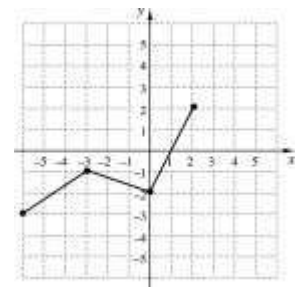
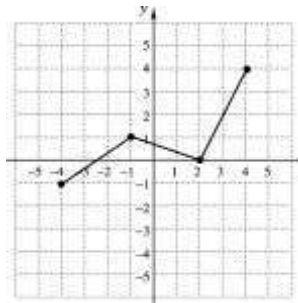

21. If $(-4, 2)$ is a point on the graph of $y = f(x)$, what point do you know is on the graph of $y = 3f(x)$?

- a) $(-4, 6)$ b) $(-12, 2)$ c) $(-12, 6)$ d) $(-4, 5)$