

**Test Bank for Economics 20th Edition by McConnell ISBN 1259450244
9781259450242**

Ful link download
Solution Manual

<https://testbankpack.com/p/solution-manual-for-economics-20th-edition-by-mcconnell-isbn-1259450244-9781259450242/>

Test Bank

<https://testbankpack.com/p/test-bank-for-economics-20th-edition-by-mcconnell-isbn-1259450244-9781259450242/>

Chapter The Market System and the
02 Circular Flow

Multiple Choice Questions

1. Which of the following is a distinguishing feature of a command system?
 - A. Private ownership of all capital.
 - B. Central planning.
 - C. Heavy reliance on markets.
 - D. Widespread dispersion of economic power.

2. Which of the following is a distinguishing feature of laissez-faire capitalism?
 - A. Public ownership of all capital.
 - B. Central planning.
 - C. Minimal government intervention.
 - D. A circular flow of goods, resources, and money.

3. Examples of command economies are:
 - A. the United States and Japan.
 - B. Sweden and Norway.
 - C. Mexico and Brazil.
 - D. Cuba and North Korea.

4. Of the following countries, which one best exhibits the characteristics of a market economy?

- A. Canada.
- B. Cuba.
- C. North Korea.
- D. Belarus.

5. The French term "laissez-faire" means:

- A. "there is no free lunch."
- B. "let it be."
- C. "circular flow."
- D. "public ownership."

6. An economic system:

- A. requires a grouping of private markets linked to one another.
- B. is a particular set of institutional arrangements and a coordinating mechanism used to respond to the economizing problem.
- C. requires some sort of centralized authority (such as government) to coordinate economic activity.
- D. is a plan or scheme that allows a firm to make money at some other firm's expense.

7. The term "laissez-faire" suggests that:

- A. land and other natural resources should be privately owned, but capital should be publicly owned.
- B. land and other natural resources should be publicly owned, but capital should be privately owned.
- C. government should not interfere with the operation of the economy.
- D. government action is absolutely necessary if the economy is to achieve full employment and full production

8. Economic systems differ according to which two main characteristics?

- A. Who owns the factors of production and the methods used to coordinate economic activity.

B. The technology used in production and the quantity and quality of natural resources.

C. How goods are produced and who gets them.

D. The political system in place and the degree of scarcity facing the economy.

9. Command systems are also known as:

A. market systems.

B. pure capitalism.

C. laissez-faire capitalism.

D. communism.

10. A fundamental difference between the command system and laissez-faire capitalism is that, in command systems:

A. the division of output is decided by central planning rather than by individuals operating freely through markets.

B. all economic decisions are made by the government, whereas there is no government in laissez-faire capitalism.

C. scarcity does not exist, whereas it does in laissez-faire capitalism.

D. money is not used, whereas it is in laissez-faire capitalism.

11. Which of the following is not a typical characteristic of a market system?

A. Private property.

B. Freedom of enterprise.

C. Government ownership of most property resources.

D. Competition in product and resource markets.

12. Which of the following is a fundamental characteristic of the market system?

- A. Property rights.
- B. Central planning by government.
- C. Unselfish behavior.
- D. Government-set wages and prices.

13. Property rights are important because they:

- A. ensure an equal distribution of income.
- B. encourage cooperation by improving the chances of mutually agreeable transactions.
- C. guarantee that any exchange will make all parties better off than prior to the exchange.
- D. allow the government to control how resources are allocated.

14. Private property:

- A. discourages cooperation because people don't want to part with what they own.
- B. discourages innovation, as people are often afraid to risk losing their own property.
- C. encourages owners to maintain or improve their property so as to preserve or enhance value.
- D. does everything indicated by the other answers.

15. Copyrights and trademarks are examples of:

- A. capital goods.
- B. human capital.
- C. property rights.
- D. public goods.

16. The regulatory mechanism of the market system is:

- A. self-interest.
- B. private property.
- C. competition.
- D. specialization.

17. Broadly defined, competition involves:

- A. private property and freedom of expression.
- B. independently acting buyers and sellers and freedom to enter or leave markets.
- C. increasing opportunity costs and diminishing marginal utility.
- D. capital goods and division of labor.

18. Competition means that:

- A. sellers can manipulate market price by causing product scarcities.
- B. there are independently acting buyers and sellers in each market.
- C. a product can be purchased at a number of different prices.
- D. there is more than one seller in a market.

19. The division of labor means that:

- A. labor markets are geographically segmented.
- B. unskilled workers outnumber skilled workers.
- C. workers specialize in various production tasks.
- D. each worker performs a large number of tasks.



Michigan
Has Surplus Autos
Wants Lettuce

Texas
Has Surplus Lettuce
Wants Apples

Washington
Has Surplus Apples
Wants Autos

On the basis of the information and assuming trade occurs between the three states, we can expect:

- A. governmental direction of the production and distribution of output can be avoided by using money.
 - B. roundabout production could not occur without the availability of money.
 - A. Washington to exchange apples with Texas and receive money in return.
 - C. it is necessary for the creation of capital goods.
 - B. Washington to exchange apples with Michigan and receive money in return.
 - D. it promotes specialization by overcoming the problems with barter.
 - C. Texas to exchange lettuce with Michigan and receive autos in return.
29. The presence of market failures implies that:
- A. money is not an effective tool for exchange in a market system.
25. B. there is an active role for government, even in a market system.
- C. individuals and firms should strive to be self-sufficient rather than specialize.
 - D. command systems are superior to market systems in the allocation of resources.
30. Which of the following characteristics is least unique to a market system?

Given the information and assuming trade occurs between the three states, we can expect:

- A. Private ownership of property resources.
 - B. Competition among buyers and sellers pursuing monetary returns.
 - C. The widespread use of money.
 - A. that there is no means by which Michigan can obtain lettuce while specializing in the production of autos and choice.
 - D. the reduction of profits.
31. Which of the following is one of the Five Fundamental Questions?
- C. money to flow counterclockwise from Michigan to Texas to Washington.
 - D. money to flow clockwise from Michigan to Washington to Texas.
26. Barter:
- A. Which products will be in scarce supply and which in excess supply?
 - B. Who should appoint the head of the central bank?
 - C. How much should society save?
 - D. What goods and services will be produced?
- A. is the major means of exchange in centrally planned economies.
- B. accounts for over 30 percent of the dollar volume of all exchange in the U.S. economy.
32. If competitive industries Z and S are making substantial economic profit, output will:
- D. be used to circumvent the problem of a lack of coincidence of wants among potential buyers and sellers.
 - A. fall in industry Z and firms will likely leave the market.
27. The "coincidence of wants" problem associated with barter refers to the fact that:
- C. expand in industry Z as more resources will move to that industry.
 - D. expand in industry Z, but no new firms will enter the market.
 - A. for exchange to occur, each seller must have a product that some buyer wants.
- B. money must be used as a medium of exchange or trade will never occur.
33. From society's point of view, the economic function of profits and losses is to:
- C. specialization is restricted by the size or scope of a market.
 - D. buyers in resource markets and sellers in product markets can never engage in exchange.
 - A. promote the equal distribution of real assets and wealth.
 - B. achieve full employment and price level stability.
 - C. contribute to a more equal distribution of income.
 - D. reallocate resources from less desired to more desired uses.
28. The use of money contributes to economic efficiency because:

34. In a market economy a significant change in consumers' desire for product X will:

- A. alter the profits or losses received by suppliers of product X.
- B. cause a reallocation of scarce resources.
- C. cause some industries to expand and others to contract.
- D. do all of these.

35. Economic profits in an industry suggest the industry:

- A. can earn more profits by increasing product price.
- B. should be larger to better satisfy consumers' desire for the product.
- C. has excess production capacity.
- D. is the size that consumers want it to be.

36. Economic profits and losses:

- A. are both considered by economists to be a part of production costs.
- B. are essential to the reallocation of resources from less desired to more desired goods.
- C. have no influence on the composition of domestic output.
- D. equalize the distribution of income in the long run.

37. If consumer desire for product X increases, all of the following will occur except:

- A. an increase in the profits of industry X.
- B. an increase in the quantity of resources employed by industry X.
- C. an increase in the output of industry X.
- D. a decrease in the quantity of resources employed in industry X.

38. An increase in consumer desire for strawberries is most likely to:

- A. increase the number of strawberry pickers needed by farmers.
- B. reduce the supply of strawberries.
- C. reduce the number of people willing to pick strawberries.
- D. reduce the need for strawberry pickers.

39. If competitive industry Y is incurring substantial losses, output will:

- A. expand as resources move toward industry Y.
- B. contract as resources move toward industry Y.
- C. contract as resources move away from industry Y.

D. expand as resources move away from industry Y.

40. The economic function of profits and losses is to:

- A. bring about a more equal distribution of income.
- B. signal that resources should be reallocated.
- C. eliminate small firms and reduce competition.
- D. tell government which industries need to be subsidized.

41. If a competitive industry is neither expanding nor contracting, we would expect:

- A. total revenue to be zero.
- B. economic profits to be zero.
- C. total opportunity cost to be zero.
- D. more resources to flow to that industry.

42. The competitive market system:

- A. encourages innovation because government provides tax breaks and subsidies to those who develop new products or new productive techniques.
- B. discourages innovation because it is difficult to acquire additional capital in the form of new machinery and equipment.
- C. discourages innovation because firms want to get all the profits possible from existing machinery and equipment.
- D. encourages innovation because successful innovators are rewarded with economic profits.

43. In a market economy, the distribution of output will be determined primarily by:

- A. consumer needs and preferences.
- B. the quantities and prices of the resources that households supply.
- C. government regulations that provide a minimum income for all.
- D. a social consensus as to which distribution of income is most equitable.

Resource	Resource	Possible Production Techniques				
	Prices	#1	#2	#3	#4	#5
Land	\$4	2	4	2	4	4
Labor	3	1	2	4	1	3
Capital	3	5	2	3	1	2
Entrepreneurial Ability	2	3	1	1	4	1

Resource	Resource	Possible Production Techniques				
	Prices	#1	#2	#3	#4	#5
Land	\$4	2	4	2	4	4
Labor	3	1	2	4	1	3
Capital	3	5	2	3	1	2
Entrepreneurial Ability	2	3	1	1	4	1

Resource	Resource	Possible Production Techniques				
	Prices	#1	#2	#3	#4	#5
Land	\$4	2	4	2	4	4
Labor	3	1	2	4	1	3
Capital	3	5	2	3	1	2
Entrepreneurial Ability	2	3	1	1	4	1

		<u>Production Techniques:</u>			
		<u>I</u>	<u>II</u>	<u>III</u>	<u>IV</u>
Labor		4	3	2	5
Capital		2	3	5	1

		<u>Production Techniques:</u>			
		<u>I</u>	<u>II</u>	<u>III</u>	<u>IV</u>
Labor		4	3	2	5
Capital		2	3	5	1

51. In a competitive market economy, firms select the least-cost production technique because:

49. Answer the question on the basis of the following information: Suppose 30 units of product A can be produced by employing just labor and capital in the four ways shown below. Assume the prices of labor and capital are \$2 and \$3 respectively. A such choice will result in full employment of available resources. B. to do so will maximize the firms' profits.

- C. this will prevent new firms from entering the industry.
- D. "dollar voting" by consumers mandates such a choice.

52. The market system's answer to the fundamental question "What will be produced?" is essentially:

Refer to the information. Which technique is economically most efficient in producing A?

- A. "Goods and services that are profitable."
- B. "Low-cost goods and services."
- C. "Goods and services that can be produced using large amounts of capital."
- D. "Goods and services that possess lasting value."
- C.III.

53. The market system's answer to the fundamental question "How will the goods and services be produced?" is essentially:

50. Answer the question on the basis of the following information: Suppose 30 units of product A can be produced by employing just labor and capital in the four ways shown below. Assume the prices of labor and capital are \$2 and \$3 respectively.

- A. "With as much machinery as possible."
- B. "Using the latest technology."
- C. "By exploiting labor."
- D. "In ways that minimize the cost per unit of output."

54. The market system's answer to the fundamental question "Who will get the goods and services?" is essentially:

Refer to the information. If the price of product A is \$0.50, the firm will realize:

- A. an economic profit of \$4.
- A. "Those willing and able to pay for them."
- B. an economic profit of \$2.
- B. "Those who physically produced them."
- C. an economic profit of \$6.
- C. "Those who most need them."
- D. a loss of \$3.
- D. "Those who get utility from them."

55. The market system's answer to the fundamental question "How will the system accommodate change?" is essentially:

- A. "Through government leadership and direction."
- B. "Through the guiding function of prices and the incentive function of profits."
- C. "Through training and retraining programs."
- D. "Through trial and error."

56. The market system's answer to the fundamental question "How will the system promote progress?" is essentially:

- A. "Through government-funded research programs."
- B. "Through redistribution of income to promote greater equality."
- C. "Through training and retraining programs."
- D. "Through the profit potential that encourages development of new technology."

57. The advent of DVDs has virtually demolished the market for videocassettes. This is an example of:

- A. creative destruction.
- B. derived demand.
- C. capital accumulation.
- D. the difference between normal and economic profits.

58. "Consumer sovereignty" refers to the:

- A. fact that resource prices are higher than product prices in capitalistic economies.
- B. idea that the pursuit of self-interest is in the public interest.
- C. idea that the decisions of producers must ultimately conform to consumer demands.
- D. fact that a federal agency exists to protect consumers from harmful and defective products.

59. The dollar votes of consumers ultimately determine the composition of output and the allocation of resources in a market economy. This statement best describes the concept of:

- A. derived demand.
- B. consumer sovereignty.
- C. the invisible hand.
- D. market failure.

60. Which of the following is not one of the five fundamental questions?

- A. What prices will be charged for goods and services?
- B. Who will get the goods and services?
- C. What goods and services will be produced?
- D. How will the system promote progress?

61. "Consumer sovereignty" means that:

- A. buyers can dictate the prices at which goods and services will be offered.
- B. advertising is ineffective because consumers already know what they want.
- C. buyers control the quality of goods and services through regulatory agencies.
- D. buyers determine what will be produced based on their "dollar votes" for the goods and services offered by sellers.

62. Which of the following best describes the invisible-hand concept?

- A. The desires of resource suppliers and producers to further their own self-interest will automatically further the public interest.
- B. The nonsubstitutability of resources creates a conflict between private and public interests and calls for government intervention.
- C. The market system is the best system for overcoming the scarce resources-unlimited wants problem.
- D. Central direction by the government will improve resource allocation in a capitalistic economy.

63. The invisible hand refers to the:

- A. fact that the U.S. tax system redistributes income from rich to poor.
- B. notion that, under competition, decisions motivated by self-interest promote the social interest.
- C. tendency of monopolistic sellers to raise prices above competitive levels.
- D. fact that government controls the functioning of the market system.

64. The invisible hand concept suggests that:

- A. market failures imply the need for a national economic plan.
- B. big businesses are inherently more efficient than small businesses.
- C. the competitiveness of a capitalistic market economy invariably diminishes over time.
- D. assuming competition, private and public interests will coincide.

65. Two major virtues of the market system are that it:

- A. allocates resources efficiently and allows economic freedom.
- B. results in an equitable personal distribution of income and always maintains full employment.
- C. results in price level stability and a fair personal distribution of income.
- D. eliminates discrimination and minimizes environmental pollution.

66. The market system:

- A. produces considerable inefficiency in the use of scarce resources.
- B. effectively harnesses the incentives of workers and entrepreneurs.
- C. is not consistent with freedom of choice in the long run.
- D. has slowly lost ground to emerging command systems.

67. According to the concept of the "invisible hand," if Susie opens and operates a profitable childcare center, then:

- A. government should regulate the business to ensure quality.
- B. the profit Susie earns indicates that she is overcharging for her services.
- C. she has served society's interests by providing a desired good or service.
- D. this demonstrates that consumer sovereignty is not present in this market.

68. The invisible hand promotes society's interests because:

- A. individuals pursuing their self-interest will try to produce goods and services that people in society want and are willing to purchase.
- B. individuals will produce goods for others out of concern for their fellow human beings.
- C. it makes sure that everyone wins from competition in the market.
- D. government regulation pushes business into producing the right mix of goods and services.

69. The coordination problem in the centrally planned economies refers to the idea that:

- A. planners had to direct required inputs to each enterprise.
- B. the price level and the level of employment were inversely related.
- C. the immediate effect of more investment was less consumption.
- D. exports had to be equal to imports for a central plan to work.

70. "Under central planning, some group has to decide how to get the necessary inputs produced in the right amounts and delivered to the right places at the right time. This is a nearly impossible task without markets and profits." This quotation best identifies the:

- A. incentive problem under central planning.
- B. coordination problem under central planning.
- C. self-sufficiency dilemma under communism.
- D. resource overcommitment problem under communism.

71. "Because the outputs of many industries are the inputs to other industries, the failure of any single industry to fulfill the output quantities specified in the central plan caused a chain reaction of adverse repercussions on production." This quotation best identifies the:

- A. incentive problem under central planning.
- B. self-sufficiency dilemma under communism.
- C. resource overcommitment problem under communism.
- D. coordination problem under central planning.

72. The incentive problem under communist central planning refers to the idea that:

- A. planners had to direct required inputs to each enterprise.
- B. workers, managers, and entrepreneurs could not personally gain by responding to shortages or surpluses or by introducing new and improved products.
- C. the immediate effect of more investment was less consumption.
- D. exports had to be equal to imports for a central plan to work.

73. Suppose that an individual sees a tremendous opportunity to produce and sell a new product but dismisses the idea because there is no way to exploit this opportunity for personal gain. This situation best identifies the:

- A. coordination problem under communist central planning.
- B. self-sufficiency dilemma under communism.
- C. asymmetric information problem under communism.
- D. incentive problem under communist central planning.

74. Innovation lagged in the centrally planned economies because:

- A. there was too much domestic business competition.
- B. there was too much competition from foreign firms.
- C. enterprises resisted innovation in fear that their production targets would be raised.
- D. exports had to equal imports for the plan to work.

75. The fact that the major indicator of enterprise success in the Soviet Union and pre-reform China was the quantity of output implied that:

- A. product quality was neglected.

- B. production costs were minimized.
- C. product-mix met consumer needs.
- D. technological advance was too rapid.

76. Enterprise managers and workers in the Soviet Union often resisted innovations in production methods because:

- A. production targets were often increased when innovation occurred.
- B. there was a chronic shortage of computers.
- C. workers could not be reallocated geographically.
- D. innovations ordinarily increased dependence on world markets.

77. If products were in short or surplus supply in the Soviet Union:

- A. price and profit signals eliminated those shortages and surpluses.
- B. price and profit signals intensified those shortages and surpluses.
- C. producers would not react because no price or profit signals occurred.
- D. the planners would immediately adjust production to achieve equilibrium.

78. In what type of business do the owners bear no personal financial responsibility for the company's debts and obligations?

- A. Partnerships.
- B. Corporations.
- C. Sole proprietorships.
- D. In all of the businesses listed in the other answers.

79. The simple circular flow model shows that:

- A. households are on the buying side of both product and resource markets.
- B. businesses are on the selling side of both product and resource markets.
- C. households are on the selling side of the resource market and on the buying side of the product market.
- D. businesses are on the buying side of the product market and on the selling side of the resource market.

80. The two basic markets shown by the simple circular flow model are:

- A. capital goods and consumer goods.
- B. free and controlled.
- C. product and resource.
- D. household and business.

81. In the resource market:

- A. businesses borrow financial capital from households.
- B. businesses sell services to households.
- C. households sell resources to businesses.
- D. firms sell raw materials to households.

82. In the simple circular flow model:

- A. households are buyers of resources.
- B. businesses are sellers of final products.
- C. households are sellers of final products.
- D. there are real flows of goods, services, and resources, but not money flows.

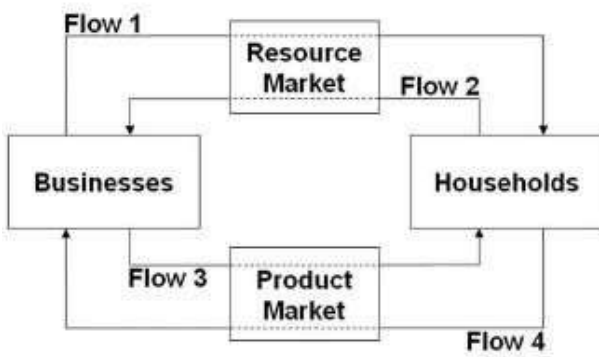
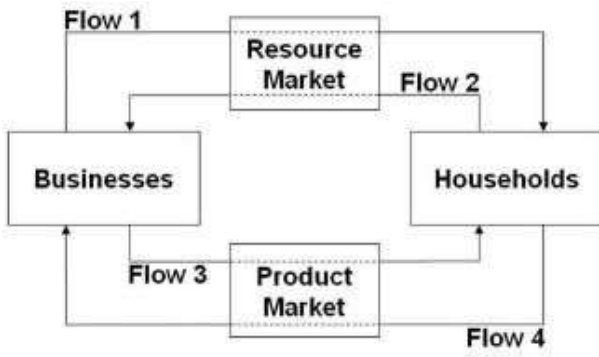

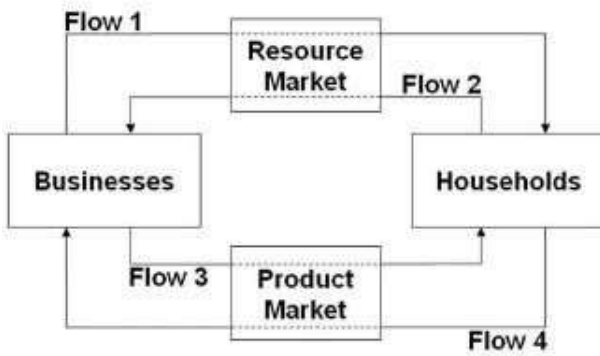
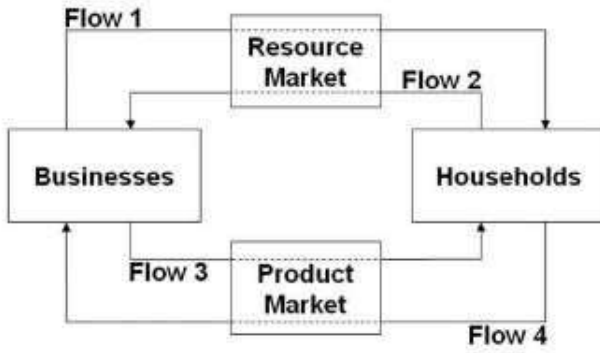

87. In terms of the circular flow diagram, households make expenditures in the _____ market and receive income through the _____ market.

- A. product; financial
- B. resource; product
- C. product; resource
- D. capital; product

88. In terms of the circular flow diagram, businesses obtain revenue through the _____ market and make expenditures in the _____ market.

- A. wage, rent, interest, and profit income.
- A. product; financial
- B. land, labor, capital, and entrepreneurial ability.
- B. resource; product
- C. goods and services.
- C. product; resource
- D. consumer expenditures.
- D. capital; product

86.

89. Households and businesses are:

- A. both buyers in the resource market.
- B. both sellers in the product market.
- C. sellers in the resource and product markets respectively.
- D. sellers in the product and resource markets respectively.

Refer to the diagram. Flow 4 represents:

- A. wage, rent, interest, and profit income.
- B. land, labor, capital, and entrepreneurial ability.
- C. goods and services.
- D. consumer expenditures.

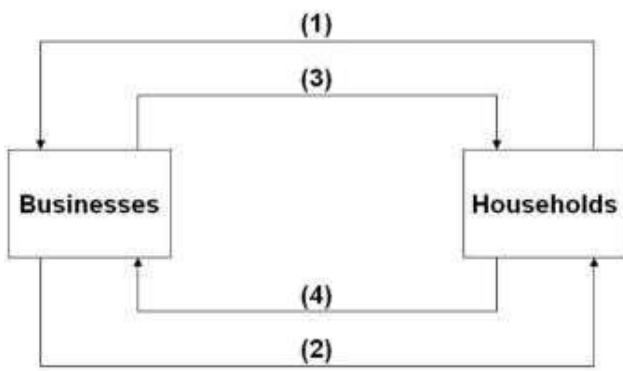
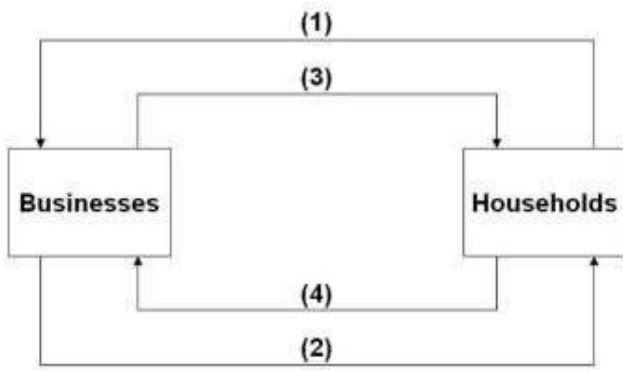

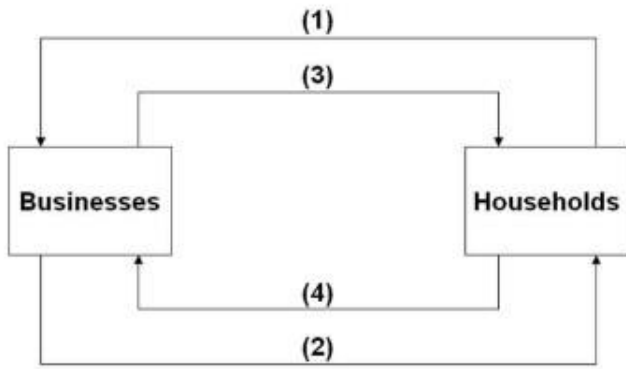

92.

95. Which of the following statements is true about risk management in market systems versus command systems?

A. Market systems manage risk better because entrepreneurs taking risks bear the costs of poor decisions, where in command systems government decision makers don't bear those costs.

B. Neither system is better than the other in terms of risk management; both systems are equally susceptible to natural disasters and changes in consumer preferences.

C. Command systems manage risk better because the government controls most economic activity and can therefore eliminate risk.

A. the money market.

D. Market systems face risk because of the possibility of profits and losses;

but command systems don't face risk because they are not profit driven.

C. the product market.

96. Risk management in command economies:

93. Which of the following best illustrates the circular flow model in action?

A. is easy because there is no risk.

B. is easy because the government controls most activity and can eliminate risk.

C. Bobbie goes to work and builds cars, and uses the income she receives to buy food at the grocery store.

D. tends to be done poorly because decision makers are insulated from the risk of making a poor decision; the owner of the furniture store uses some of the money from the sale to pay her supplier, and uses the rest to take her family out to dinner.

97. In a market system:

C. Boeing experiences a surge in orders for new airplanes, prompting the company to hire more workers.

D. All of these answers illustrate the workings of the circular flow model.

A. firm owners and employees share business risk more or less equally.

B. a firm's employees and suppliers are largely shielded from risk.

94. Risk is a problem faced:

C. employees and suppliers face the greatest risks because firms can shut down without notice and leave them unpaid.

D. a firm's owners are largely shielded from risk because they can walk away from the business at any time.

A. only in market systems.

B. only in command systems.

C. in both market systems and command systems.

D. in neither market systems nor command systems, only in laissez-faire capitalism.

98. In a market system, employees and suppliers:

- A. are usually shielded from risk, but at the cost of not sharing in the profits of the firm.
- B. are usually shielded from risk and share in the profits of the firm.
- C. are generally subject to as much risk as firm owners but get to share in the profits.
- D. bear as much risk as firm owners but don't get to share in the profits.

99. A market system tends to restrict business risk to owners and investors. This results in which of the following benefits?

- A. A more stable macroeconomy with fewer recessions.
- B. Firms are better able to attract inputs, as these inputs do not have to share the risk.
- C. Government agencies are better prepared to help when businesses fail.
- D. Consistently lower prices for consumers.

100. A market system tends to restrict business risk to owners and investors. This results in which of the following benefits?

- A. It encourages more people to become entrepreneurs.
- B. Firms have to pay more to attract inputs, as these inputs have to share the risk.
- C. Firms focus attention on prudent risk management, as it is profitable to manage risk.
- D. Income becomes more equally distributed.

101. (Consider This) In 1975, McDonald's introduced its Egg McMuffin breakfast sandwich, which remains popular and profitable today. This longevity illustrates the idea of:

- A. opportunity cost.
- B. upsloping supply.
- C. consumer sovereignty.
- D. specialization.

102.(Consider This) In 2000, McDonald's introduced its McSalad Shaker, which failed to catch on with the public and was subsequently dropped from the menu. This failure illustrates the idea of:

- A. consumer sovereignty.
- B. technological change.
- C. downsloping demand.
- D. specialization.

103. (Consider This) Since World War II:

- A. North Korea's command economy has significantly outperformed South Korea's market economy.
- B. South Korea's command economy has significantly outperformed North Korea's market economy.
- C. North Korea's market economy has significantly outperformed South Korea's command economy.
- D. South Korea's market economy has significantly outperformed North Korea's command economy.

104. (Consider This) North Korea's command economy:

- A. is one of the few remaining command economies.
- B. has grown much faster than South Korea's economy since the two countries were divided after World War II.
- C. produces a per capita GDP of nearly \$25,000.
- D. has undergone significant market reforms and is now one of the fastest-growing economies.

105. (Consider This) Which of the following statements about insurance and risk is true?

- A. Insurance inhibits economic growth and investment by discouraging risk-taking.
- B. Insurance transfers risk from those with a high tolerance for risk to those with a low tolerance for risk.
- C. Insurance companies always earn profits because insurance premiums always exceed the payout for insured events.
- D. Insurance transfers risk from those with a low tolerance for risk to those with a higher tolerance for risk.

106. (Consider This) Martha's Milkshake Company buys earthquake insurance from the Stable Ground Insurance Company. Based on this purchase, economists would conclude that:

- A. Martha's believes a damaging earthquake is imminent.
- B. Stable Ground believes no damaging earthquakes will occur.
- C. Martha's has a lower tolerance for earthquake risk than Stable Ground.
- D. Martha's has a greater tolerance for earthquake risk than Stable Ground.

107. (Last Word) According to economist Donald Boudreaux, the world's tens of billions of individual resources get arranged productively:

- A. because government has become highly effective at central planning.
- B. because private property encourages people to consider the alternative uses of their resources and select those that provide the most rewards.
- C. because people tend to be creative and orderly.
- D. through random trial and error.

108. (Last Word) According to economist Donald Boudreaux:

- A. private property eliminates the possibility that resource arrangements will be random.
- B. the market system threatens to do irreparable harm to the world's ecosystem.
- C. arranging resources under the market system is much like shuffling a deck of cards.
- D. the market system works wondrously for advanced industrial nations but not for developing nations.

True / False Questions

109. Market economies use capital goods because they improve

productive efficiency. True False

110. Money functions as a medium of exchange by eliminating the need for a

coincidence of wants. True False

111. Consumer sovereignty means that legislation now protects the rights of consumers to dispose of their incomes as they see fit.

True False

112. Specialization may expand total output even though the individuals involved may have identical abilities.

True False

113. The wants of consumers are expressed in the product market with

"dollar votes." True False

114. Costs can be defined as total payments made to workers, land owners, and capital suppliers less payments to the entrepreneur for organizing and combining the other resources used to produce a good.

True False

115. Continued losses in an industry will cause some firms to reduce output or eventually leave the industry.

True False

116. The guiding function of prices tends to keep resources flowing toward their most highly valued uses.

True False

117. The invisible hand refers to the many indirect controls that the federal government imposes in a market system.

True False

118. Central planning in the Soviet Union and pre-reform China emphasized the expansion of the production of consumer goods to raise the domestic standard of living.

True False

119. Central planning often suffers from a coordination problem and an incentive problem. True False

Chapter 02 The Market System and the Circular Flow

Answer Key

Multiple Choice Questions

1. Which of the following is a distinguishing feature of a command system?

- A. Private ownership of all capital.
- B. Central planning.**
- C. Heavy reliance on markets.
- D. Widespread dispersion of economic power.

AACSB: Analytic

Accessibility: Keyboard Navigation

Blooms: Remember

Difficulty: 1 Easy

Learning Objective: 02-01 Differentiate between laissez-faire capitalism; the command system; and the market system.

Topic: Economic systems

2. Which of the following is a distinguishing feature of laissez-faire capitalism?

- A. Public ownership of all capital.
- B. Central planning.
- C. Minimal government intervention.**
- D. A circular flow of goods, resources, and money.

AACSB: Analytic

Accessibility: Keyboard Navigation

Blooms: Remember

Difficulty: 1 Easy

Learning Objective: 02-01 Differentiate between laissez-faire capitalism; the command system; and the market system.

Topic: Economic systems

3. Examples of command economies are:

- A. the United States and Japan.
- B. Sweden and Norway.
- C. Mexico and Brazil.
- D. Cuba and North Korea.

AACSB: Reflective Thinking
Accessibility: Keyboard Navigation
Blooms: Understand
Difficulty: 2 Medium

Learning Objective: 02-01 Differentiate between laissez-faire capitalism; the command system; and the market system.

Topic: Economic systems

4. Of the following countries, which one best exhibits the characteristics of a market economy?

- A. Canada.
- B. Cuba.
- C. North Korea.
- D. Belarus.

AACSB: Reflective Thinking
Accessibility: Keyboard Navigation
Blooms: Understand
Difficulty: 2 Medium

Learning Objective: 02-01 Differentiate between laissez-faire capitalism; the command system; and the market system.

Topic: Economic systems

5. The French term "laissez-faire" means:

- A. "there is no free lunch."
- B. "let it be."
- C. "circular flow."
- D. "public ownership."

AACSB: Analytic
Accessibility: Keyboard Navigation

Blooms: Remember

Difficulty: 1 Easy

Learning Objective: 02-01 Differentiate between laissez-faire capitalism; the command system; and the market system.

Topic: Economic systems

6. An economic system:

A. requires a grouping of private markets linked to one another.

B. is a particular set of institutional arrangements and a coordinating mechanism used to respond to the economizing problem.

C. requires some sort of centralized authority (such as government) to coordinate economic activity.

D. is a plan or scheme that allows a firm to make money at some other firm's expense.

AACSB: Analytic

Accessibility: Keyboard Navigation

Blooms: Remember

Difficulty: 1 Easy

Learning Objective: 02-01 Differentiate between laissez-faire capitalism; the command system; and the market system.

Topic: Economic systems

7. The term "laissez-faire" suggests that:

A. land and other natural resources should be privately owned, but capital should be publicly owned.

B. land and other natural resources should be publicly owned, but capital should be privately owned.

C. government should not interfere with the operation of the economy.

D. government action is absolutely necessary if the economy is to achieve full employment and full production.

AACSB:
Analytic

Accessibility: Keyboard
Navigation

Blooms:
Understand

Difficulty: 2
Medium

Learning Objective: 02-01 Differentiate between laissez-faire capitalism; the command system; and the market system.

Topic: Economic systems

8. Economic systems differ according to which two main characteristics?

- A. Who owns the factors of production and the methods used to coordinate economic activity.
- B. The technology used in production and the quantity and quality of natural resources.
- C. How goods are produced and who gets them.
- D. The political system in place and the degree of scarcity facing the economy.

AACSB: Analytic
Accessibility: Keyboard Navigation
Blooms: Remember
Difficulty: 1 Easy

Learning Objective: 02-01 Differentiate between laissez-faire capitalism; the command system; and the market system.

Topic: Economic systems

9. Command systems are also known as:

- A. market systems.
- B. pure capitalism.
- C. laissez-faire capitalism.
- D. **communism.**

AACSB: Analytic
Accessibility: Keyboard Navigation
Blooms: Remember
Difficulty: 1 Easy

Learning Objective: 02-01 Differentiate between laissez-faire capitalism; the command system; and the market system.

Topic: Economic systems

10. A fundamental difference between the command system and laissez-faire capitalism is that, in command systems:

- A. **the division of output is decided by central planning rather than by individuals operating freely through markets.**
- B. all economic decisions are made by the government, whereas there is no government in laissez-faire capitalism.
- C. scarcity does not exist, whereas it does in laissez-faire capitalism.
- D. money is not used, whereas it is in laissez-faire capitalism.

AACSB:
Analytic
Accessibility: Keyboard Navigation
Blooms:
Understand
Difficulty: 2
Medium

Learning Objective: 02-01 Differentiate between laissez-faire capitalism; the command system; and the market system.

Topic: Economic systems

11. Which of the following is not a typical characteristic of a market system?

- A. Private property.
- B. Freedom of enterprise.
- C. Government ownership of most property resources.
- D. Competition in product and resource markets.

AACSB: Analytic

Accessibility: Keyboard Navigation

Blooms: Remember

Difficulty: 1 Easy

Learning Objective: 02-02 List the main characteristics of the market system.

Topic: Characteristics of the market system

12. Which of the following is a fundamental characteristic of the market system?

- A. Property rights.
- B. Central planning by government.
- C. Unselfish behavior.
- D. Government-set wages and prices.

AACSB: Analytic

Accessibility: Keyboard Navigation

Blooms: Remember

Difficulty: 1 Easy

Learning Objective: 02-02 List the main characteristics of the market system.

Topic: Characteristics of the market system

13. Property rights are important because they:

- A. ensure an equal distribution of income.
- B. encourage cooperation by improving the chances of mutually agreeable transactions.
- C. guarantee that any exchange will make all parties better off than prior to the exchange.
- D. allow the government to control how resources are allocated.

AACSB: Analytic

Blooms: Understand

Difficulty: 2 Medium

Learning Objective: 02-02 List the main characteristics of the market system.

Topic: Characteristics of the market system

14. Private property:

- A. discourages cooperation because people don't want to part with what they own.

B. discourages innovation, as people are often afraid to risk losing their own property.

C. encourages owners to maintain or improve their property so as to preserve or enhance value.

D. does everything indicated by the other answers.

AACSB: Analytic

Accessibility: Keyboard Navigation

Blooms: Understand

Difficulty: 2 Medium

Learning Objective: 02-02 List the main characteristics of the market system.

Topic: Characteristics of the market system

15. Copyrights and trademarks are examples of:

A. capital goods.

B. human capital.

C. property rights.

D. public goods.

AACSB: Analytic

Accessibility: Keyboard Navigation

Blooms: Understand

Difficulty: 2 Medium

Learning Objective: 02-02 List the main characteristics of the market system.

Topic: Characteristics of the market system

16. The regulatory mechanism of the market system is:

A. self-interest.

B. private property.

C. competition.

D. specialization.

AACSB: Analytic

Accessibility: Keyboard Navigation

Blooms: Understand

Difficulty: 2 Medium

Learning Objective: 02-02 List the main characteristics of the market system.

Topic: Characteristics of the market system

17. Broadly defined, competition involves:

- A. private property and freedom of expression.
- B. independently acting buyers and sellers and freedom to enter or leave markets.
- C. increasing opportunity costs and diminishing marginal utility.
- D. capital goods and division of labor.

AACSB: Analytic

Accessibility: Keyboard Navigation

Blooms: Remember

Difficulty: 1 Easy

Learning Objective: 02-02 List the main characteristics of the market system.

Topic: Characteristics of the market system

18. Competition means that:

- A. sellers can manipulate market price by causing product scarcities.
- B. there are independently acting buyers and sellers in each market.
- C. a product can be purchased at a number of different prices.
- D. there is more than one seller in a market.

AACSB: Analytic

Accessibility: Keyboard Navigation

Blooms: Understand

Difficulty: 2 Medium

Learning Objective: 02-02 List the main characteristics of the market system.

Topic: Characteristics of the market system

19. The division of labor means that:

- A. labor markets are geographically segmented.
- B. unskilled workers outnumber skilled workers.
- C. workers specialize in various production tasks.
- D. each worker performs a large number of tasks.

AACSB: Analytic

Accessibility: Keyboard Navigation

Blooms: Remember

Difficulty: 1 Easy

Learning Objective: 02-02 List the main characteristics of the market system.

Topic: Characteristics of the market system

20. Specialization in production is important primarily because it:

- A. results in greater total output.
- B. allows society to avoid the coincidence-of-wants problem.
- C. allows society to trade by barter.
- D. allows society to have fewer capital goods.

AACSB: Analytic

Accessibility: Keyboard Navigation

Blooms: Understand

Difficulty: 2 Medium

Learning Objective: 02-02 List the main characteristics of the market system.

Topic: Characteristics of the market system

21. Specialization—the division of labor—enhances productivity and efficiency by:

- A. allowing workers to take advantage of existing differences in their abilities and skills.
- B. avoiding the time loss involved in shifting from one production task to another.
- C. allowing workers to develop skills by working on one, or a limited number, of tasks.
- D. all of the means identified in the other answers.

AACSB: Analytic

Accessibility: Keyboard Navigation

Blooms: Understand

Difficulty: 2 Medium

Learning Objective: 02-02 List the main characteristics of the market system.

Topic: Characteristics of the market system

22. Specialization in production is economically beneficial primarily because it:

- A. allows everyone to have a job that he or she likes.
- B. permits the production of a larger output with fixed amounts of resources.
- C. facilitates trade by bartering.
- D. guarantees full employment.

AACSB: Analytic

Accessibility: Keyboard Navigation

Blooms: Understand

Difficulty: 2 Medium

Learning Objective: 02-02 List the main characteristics of the market system.

Michigan
Has Surplus Autos
Wants Lettuce

Texas
Has Surplus Lettuce
Wants Apples

Washington
Has Surplus Apples
Wants Autos



Learning Objective: 02-02 List the main characteristics of the market system.

Topic: Characteristics of the market system

Type: Figure

26. Barter:

- 24. A. is the major means of exchange in centrally planned economies.
- B. accounts for over 30 percent of the dollar volume of all exchange in the U.S. economy.
- C. entails the exchange of goods for goods.
- D. is used to circumvent the problem of a lack of coincidence of wants among potential buyers and sellers.

On the basis of the information and assuming trade occurs between the three states, we can expect:

AACSB: Analytic

Accessibility: Keyboard Navigation

Blooms: Remember

Difficulty: 1 Easy

Learning Objective: 02-02 List the main characteristics of the market system.

A. Washington to exchange apples with Texas and receive money in return.

Topic: Characteristics of the market system

B. Washington to exchange apples with Michigan and receive money in return.

27. The basic coincidence of wants problem with Michigan and Washington is solved for the fact that:

D. Texas to trade lettuce directly for Washington apples.

A. for exchange to occur, each seller must have a product that some buyer wants.

AACSB: Reflective Thinking

B. money must be used as a medium of exchange or trade will never occur.

Blooms: Apply

Difficulty: 2 Medium

C. specialization is restricted by the size or scope of a market.

Learning Objective: 02-02 List the main characteristics of the market system.

D. buyers in resource markets and sellers in product markets can never engage in exchange.

Topic: Characteristics of the market system

Type: Figure

25.

AACSB: Analytic

Accessibility: Keyboard Navigation

Blooms: Understand

Difficulty: 2 Medium

Learning Objective: 02-02 List the main characteristics of the market system.

Topic: Characteristics of the market system

Given the information and assuming trade occurs between the three states, we can expect:

A. that there is no means by which Michigan can obtain lettuce while specializing in the production of autos.

B. that money will not be needed to accomplish the desired exchanges.

C. money to flow counterclockwise from Michigan to Texas to Washington.

D. money to flow clockwise from Michigan to Washington to Texas.

AACSB: Reflective Thinking

28. The use of money contributes to economic efficiency because:

- A. governmental direction of the production and distribution of output can be avoided by using money.
- B. roundabout production could not occur without the availability of money.
- C. it is necessary for the creation of capital goods.
- D. **it promotes specialization by overcoming the problems with barter.**

AACSB: Analytic

Accessibility: Keyboard Navigation

Blooms: Understand

Difficulty: 2 Medium

Learning Objective: 02-02 List the main characteristics of the market system.

Topic: Characteristics of the market system

29. The presence of market failures implies that:

- A. money is not an effective tool for exchange in a market system.
- B. **there is an active role for government, even in a market system.**
- C. individuals and firms should strive to be self-sufficient rather than specialize.
- D. command systems are superior to market systems in the allocation of resources.

AACSB: Analytic

Accessibility: Keyboard Navigation

Blooms: Understand

Difficulty: 2 Medium

Learning Objective: 02-02 List the main characteristics of the market system.

Topic: Characteristics of the market system

30. Which of the following characteristics is least unique to a market system?

- A. Private ownership of property resources.
- B. Competition among buyers and sellers pursuing monetary returns.
- C. **The widespread use of money.**
- D. Freedom of enterprise and choice.

AACSB:
Analytic

Accessibility: Keyboard Navigation
Blooms: Understand
Difficulty: 2 Medium

Learning Objective: 02-02 List the main characteristics of the market system.

Topic: Characteristics of the market system

31. Which of the following is one of the Five Fundamental Questions?

- A. Which products will be in scarce supply and which in excess supply?
- B. Who should appoint the head of the central bank?
- C. How much should society save?
- D. What goods and services will be produced?

AACSB: Analytic

Accessibility: Keyboard Navigation

Blooms: Remember

Difficulty: 1 Easy

Learning Objective: 02-03 Explain how the market system answers the five fundamental questions of what to produce; how to produce; who obtains the output; how to adjust to change; and how to promote progress. Topic: Five fundamental questions

32. If competitive industry Z is making substantial economic profit, output will:

- A. fall in industry Z and firms will likely leave the market.
- B. fall in all industries except industry Z.
- C. expand in industry Z as more resources will move to that industry.
- D. expand in industry Z, but no new firms will enter the market.

AACSB: Reflective Thinking

Accessibility: Keyboard Navigation

Blooms: Apply

Difficulty: 2 Medium

Learning Objective: 02-03 Explain how the market system answers the five fundamental questions of what to produce; how to produce; who obtains the output; how to adjust to change; and how to promote progress.

Learning Objective: 02-04 Explain the operation of the "invisible hand" and why market economies usually do a better job than command economies at efficiently transforming economic resources into desirable output. Topic: Five fundamental questions

Topic: Invisible hand

33. From society's point of view, the economic function of profits and losses is to:

- A. promote the equal distribution of real assets and wealth.
- B. achieve full employment and price level stability.
- C. contribute to a more equal distribution of income.
- D. reallocate resources from less desired to more desired uses.

AACSB: Reflective Thinking
Accessibility: Keyboard Navigation
Blooms: Understand
Difficulty: 2 Medium

Learning Objective: 02-03 Explain how the market system answers the five fundamental questions of what to produce; how to produce; who obtains the output; how to adjust to change; and how to promote progress.

Learning Objective: 02-04 Explain the operation of the "invisible hand" and why market economies usually do a better job than command economies at efficiently transforming economic resources into desirable output.
Topic: Five fundamental questions

Topic: Invisible hand

34. In a market economy a significant change in consumers' desire for product X will:

- A. alter the profits or losses received by suppliers of product X.
- B. cause a reallocation of scarce resources.
- C. cause some industries to expand and others to contract.
- D. do all of these.

AACSB: Reflective Thinking
Accessibility: Keyboard Navigation
Blooms: Apply
Difficulty: 2 Medium

Learning Objective: 02-03 Explain how the market system answers the five fundamental questions of what to produce; how to produce; who obtains the output; how to adjust to change; and how to promote progress.

Learning Objective: 02-04 Explain the operation of the "invisible hand" and why market economies usually do a better job than command economies at efficiently transforming economic resources into desirable output.
Topic: Five fundamental questions
Topic: Invisible hand

35. Economic profits in an industry suggest the industry:

- A. can earn more profits by increasing product price.
- B. should be larger to better satisfy consumers' desire for the product.
- C. has excess production capacity.
- D. is the size that consumers want it to be.

AACSB: Reflective Thinking
Accessibility: Keyboard Navigation
Blooms: Analyze
Difficulty: 3 Hard

Learning Objective: 02-03 Explain how the market system answers the five fundamental questions of what to produce; how to produce; who obtains the output; how to adjust to change; and how to promote progress. Topic: Five fundamental questions

36. Economic profits and losses:

- A. are both considered by economists to be a part of production costs.

B. are essential to the reallocation of resources from less desired to more desired goods.

C. have no influence on the composition of domestic output.

D. equalize the distribution of income in the long run.

AACSB:
Analytic

Accessibility: Keyboard
Navigation

Blooms:
Understand

Difficulty: 2
Medium

Learning Objective: 02-03 Explain how the market system answers the five fundamental questions of what to produce; how to produce; who obtains the output; how to adjust to change; and how to promote progress.

Learning Objective: 02-04 Explain the operation of the "invisible hand" and why market economies usually do a better job than command economies at efficiently transforming economic resources into desirable output.
Topic: Five fundamental questions

Topic: Invisible hand

37. If consumer desire for product X increases, all of the following will occur except:

A. an increase in the profits of industry X.

B. an increase in the quantity of resources employed by industry X.

C. an increase in the output of industry X.

D. a decrease in the quantity of resources employed in industry X.

AACSB: Reflective Thinking

Accessibility: Keyboard Navigation

Blooms: Apply

Difficulty: 2 Medium

Learning Objective: 02-03 Explain how the market system answers the five fundamental questions of what to produce; how to produce; who obtains the output; how to adjust to change; and how to promote progress.

Learning Objective: 02-04 Explain the operation of the "invisible hand" and why market economies usually do a better job than command economies at efficiently transforming economic resources into desirable output.
Topic: Five fundamental questions

Topic: Invisible hand

38. An increase in consumer desire for strawberries is most likely to:

A. increase the number of strawberry pickers needed by farmers.

B. reduce the supply of strawberries.

C. reduce the number of people willing to pick strawberries.

D. reduce the need for strawberry pickers.

AACSB: Reflective Thinking

Accessibility: Keyboard Navigation

Blooms: Apply

Difficulty: 2 Medium

Learning Objective: 02-03 Explain how the market system answers the five fundamental questions of what to produce; how to produce; who obtains the output; how to adjust to change; and how to promote progress.

Learning Objective: 02-04 Explain the operation of the "invisible hand" and why market economies usually do a better job than command economies at efficiently transforming economic resources into desirable output.

Topic: Five fundamental questions

Topic: Invisible hand

39. If competitive industry Y is incurring substantial losses, output will:

- A. expand as resources move toward industry Y.
- B. contract as resources move toward industry Y.
- C. contract as resources move away from industry Y.
- D. expand as resources move away from industry Y.

AACSB: Reflective Thinking

Accessibility: Keyboard Navigation

Blooms: Understand

Difficulty: 2 Medium

Learning Objective: 02-03 Explain how the market system answers the five fundamental questions of what to produce; how to produce; who obtains the output; how to adjust to change; and how to promote progress.

Learning Objective: 02-04 Explain the operation of the "invisible hand" and why market economies usually do a better job than command economies at efficiently transforming economic resources into desirable output.

Topic: Five fundamental questions

Topic: Invisible hand

40. The economic function of profits and losses is to:

- A. bring about a more equal distribution of income.
- B. signal that resources should be reallocated.
- C. eliminate small firms and reduce competition.
- D. tell government which industries need to be subsidized.

AACSB:
Analytic

Accessibility: Keyboard
Navigation

Blooms:
Understand

Difficulty: 2
Medium

Learning Objective: 02-03 Explain how the market system answers the five fundamental questions of what to produce; how to produce; who obtains the output; how to adjust to change; and how to promote progress.

Learning Objective: 02-04 Explain the operation of the "invisible hand" and why market economies usually do a better job than command economies at efficiently transforming economic resources into desirable output.

Topic: Five fundamental questions

Topic: Invisible hand

41. If a competitive industry is neither expanding nor contracting, we would expect:

- A. total revenue to be zero.
- B. economic profits to be zero.**
- C. total opportunity cost to be zero.
- D. more resources to flow to that industry.

AACSB: Reflective Thinking
Accessibility: Keyboard Navigation
Blooms: Understand
Difficulty: 2 Medium

Learning Objective: 02-03 Explain how the market system answers the five fundamental questions of what to produce; how to produce; who obtains the output; how to adjust to change; and how to promote progress. Topic: Five fundamental questions

42. The competitive market system:

- A. encourages innovation because government provides tax breaks and subsidies to those who develop new products or new productive techniques.
- B. discourages innovation because it is difficult to acquire additional capital in the form of new machinery and equipment.
- C. discourages innovation because firms want to get all the profits possible from existing machinery and equipment.
- D. encourages innovation because successful innovators are rewarded with economic profits.**

AACSB: Reflective Thinking
Accessibility: Keyboard Navigation
Blooms: Understand
Difficulty: 2 Medium

Learning Objective: 02-03 Explain how the market system answers the five fundamental questions of what to produce; how to produce; who obtains the output; how to adjust to change; and how to promote progress. Topic: Five fundamental questions

43. In a market economy, the distribution of output will be determined primarily by:

- A. consumer needs and preferences.
- B. the quantities and prices of the resources that households supply.**
- C. government regulations that provide a minimum income for all.
- D. a social consensus as to which distribution of income is most equitable.

AACSB:
Analytic

Accessibility: Keyboard
Navigation

Blooms:
Understand

Difficulty: 2
Medium

Learning Objective: 02-03 Explain how the market system answers the five fundamental questions of what to produce; how to produce; who obtains the output; how to adjust to change; and how to promote progress. Topic: Five fundamental questions

44. The most efficient combination of resources in producing a given output is the combination that:

- A. comes closest to using the same quantities of land, labor, capital, and entrepreneurial ability.
- B. minimize the cost per unit of output.**
- C. uses the smallest total quantity of all resources.
- D. conserves most on the use of labor.

AACSB: Analytic

Accessibility: Keyboard Navigation

Blooms: Remember

Difficulty: 1 Easy

Learning Objective: 02-03 Explain how the market system answers the five fundamental questions of what to produce; how to produce; who obtains the output; how to adjust to change; and how to promote progress. Topic: Five fundamental questions

Resource	Resource	Possible Production Techniques				
	Prices	#1	#2	#3	#4	#5
Land	\$4	2	4	2	4	4
Labor	3	1	2	4	1	3
Capital	3	5	2	3	1	2
Entrepreneurial Ability	2	3	1	1	4	1

Resource	Resource	Possible Production Techniques				
	Prices	#1	#2	#3	#4	#5
Land	\$4	2	4	2	4	4
Labor	3	1	2	4	1	3
Capital	3	5	2	3	1	2
Entrepreneurial Ability	2	3	1	1	4	1

AACSB:
Analytic Blooms: Analyze Difficulty: 3 Hard

Resource	Resource	Possible Production Techniques				
	Prices	#1	#2	#3	#4	#5
Land	\$4	2	4	2	4	4
Labor	3	1	2	4	1	3
Capital	3	5	2	3	1	2
Entrepreneurial Ability	2	3	1	1	4	1

Production Techniques:

	I	II	III	IV
Labor	4	3	2	5
Capital	2	3	5	1

	Production Techniques:			
	I	II	III	IV
Labor	4	3	2	5
Capital	2	3	5	1

A. such choices will result in full employment of available resources.

B. to do so will maximize the firms' profits.

C. this will prevent new firms from entering the industry.

D. "dollar voting" by consumers mandates such a choice.

AACSB: Reflective Thinking
Accessibility: Keyboard Navigation
Blooms: Understand
Difficulty: 2 Medium

Learning Objective: 02-03 Explain how the market system answers the five fundamental questions of what to produce; how to produce; who obtains the output; how to adjust to change; and how to promote progress. Topic: Five fundamental questions

52. The market system's answer to the fundamental question "What will be produced?" is essentially:

A. "Goods and services that are profitable."

50. ~~Answer the question on the basis of the following information: Suppose 30 units of product A can be produced by employing just labor and capital in the four ways show below. Assume the prices of labor and capital are \$2 and \$3 respectively.~~
A. "Goods and services that can be produced using large amounts of capital."
B. "Goods and services that possess lasting value."

AACSB: Reflective Thinking
Accessibility: Keyboard Navigation
Blooms: Understand
Difficulty: 2 Medium

Learning Objective: 02-03 Explain how the market system answers the five fundamental questions of what to produce; how to produce; who obtains the output; how to adjust to change; and how to promote progress. Topic: Five fundamental questions

Refer to the information. If the price of product A is \$0.50, the firm will realize:

53. The market system's answer to the fundamental question "How will the goods and services be produced?" is essentially:

A. an economic profit of \$4.

B. an economic profit of \$2.

C. an economic profit of \$6.

~~A. "With as much machinery as possible."~~

~~D. a loss of \$3.~~

B. "Using the latest technology."

C. "By exploiting labor."

D. "In ways that minimize the cost per unit of output."

AACSB: Analytic

Blooms: Apply

Difficulty: 2
AACSB: Reflective Thinking
Medium

Accessibility: Keyboard Navigation

Learning Objective: 02-03 Explain how the market system answers the five fundamental questions of what to produce; how to produce; who obtains the output; how to adjust to change; and how to promote progress. Topic: Five fundamental questions

Blooms: Understand

Difficulty: 2 Medium

Learning Objective: 02-03 Explain how the market system answers the five fundamental questions of what to produce; how to produce; who obtains the output; how to adjust to change; and how to promote progress. Topic: Five fundamental questions

Type: Table

51. In a competitive market economy, firms select the least-cost production technique because:

54. The market system's answer to the fundamental question "Who will get the goods and services?" is essentially:

- A. "Those willing and able to pay for them."
- B. "Those who physically produced them."
- C. "Those who most need them."
- D. "Those who get utility from them."

AACSB: Reflective Thinking
Accessibility: Keyboard Navigation
Blooms: Understand
Difficulty: 2 Medium

Learning Objective: 02-03 Explain how the market system answers the five fundamental questions of what to produce; how to produce; who obtains the output; how to adjust to change; and how to promote progress. Topic: Five fundamental questions

55. The market system's answer to the fundamental question "How will the system accommodate change?" is essentially:

- A. "Through government leadership and direction."
- B. "Through the guiding function of prices and the incentive function of profits."
- C. "Through training and retraining programs."
- D. "Through trial and error."

AACSB: Reflective Thinking
Accessibility: Keyboard Navigation
Blooms: Understand
Difficulty: 2 Medium

Learning Objective: 02-03 Explain how the market system answers the five fundamental questions of what to produce; how to produce; who obtains the output; how to adjust to change; and how to promote progress. Topic: Five fundamental questions

56. The market system's answer to the fundamental question "How will the system promote progress?" is essentially:

- A. "Through government-funded research programs."
- B. "Through redistribution of income to promote greater equality."
- C. "Through training and retraining programs."
- D. "Through the profit potential that encourages development of new technology."

AACSB: Reflective Thinking
Accessibility: Keyboard Navigation
Blooms: Understand
Difficulty: 2 Medium

Learning Objective: 02-03 Explain how the market system answers the five fundamental questions of what to produce; how to produce; who obtains the output; how to adjust to change; and how to promote progress. Topic: Five fundamental questions

57. The advent of DVDs has virtually demolished the market for videocassettes. This is an example of:

A. creative destruction.

- B. derived demand.
- C. capital accumulation.
- D. the difference between normal and economic profits.

AACSB: Reflective Thinking
Accessibility: Keyboard Navigation
Blooms: Apply
Difficulty: 2 Medium

Learning Objective: 02-03 Explain how the market system answers the five fundamental questions of what to produce; how to produce; who obtains the output; how to adjust to change; and how to promote progress. Topic: Five fundamental questions

58. "Consumer sovereignty" refers to the:

- A. fact that resource prices are higher than product prices in capitalistic economies.
- B. idea that the pursuit of self-interest is in the public interest.
- C. **idea that the decisions of producers must ultimately conform to consumer demands.**
- D. fact that a federal agency exists to protect consumers from harmful and defective products.

AACSB:
Analytic

Accessibility: Keyboard
Navigation

Blooms:
Understand

Difficulty: 2
Medium

Learning Objective: 02-03 Explain how the market system answers the five fundamental questions of what to produce; how to produce; who obtains the output; how to adjust to change; and how to promote progress. Topic: Five fundamental questions

59. The dollar votes of consumers ultimately determine the composition of output and the allocation of resources in a market economy. This statement best describes the concept of:

- A. derived demand.
- B. **consumer sovereignty.**
- C. the invisible hand.
- D. market failure.

AACSB: Analytic

Accessibility: Keyboard Navigation

Blooms: Remember

Difficulty: 1 Easy

Learning Objective: 02-03 Explain how the market system answers the five fundamental questions of what to produce; how to produce; who obtains the output; how to adjust to change; and how to promote progress. Topic: Five fundamental questions

60. Which of the following is not one of the five fundamental questions?

- A. What prices will be charged for goods and services?
- B. Who will get the goods and services?
- C. What goods and services will be produced?
- D. How will the system promote progress?

AACSB: Analytic

Accessibility: Keyboard Navigation

Blooms: Remember

Difficulty: 1 Easy

Learning Objective: 02-03 Explain how the market system answers the five fundamental questions of what to produce; how to produce; who obtains the output; how to adjust to change; and how to promote progress. Topic: Five fundamental questions

61. "Consumer sovereignty" means that:

- A. buyers can dictate the prices at which goods and services will be offered.
- B. advertising is ineffective because consumers already know what they want.
- C. buyers control the quality of goods and services through regulatory agencies.
- D. buyers determine what will be produced based on their "dollar votes" for the goods and services offered by sellers.

AACSB:
Analytic

Accessibility: Keyboard
Navigation

Blooms:
Understand

Difficulty: 2
Medium

Learning Objective: 02-03 Explain how the market system answers the five fundamental questions of what to produce; how to produce; who obtains the output; how to adjust to change; and how to promote progress. Topic: Five fundamental questions

62. Which of the following best describes the invisible-hand concept?

- A. The desires of resource suppliers and producers to further their own self-interest will automatically further the public interest.
- B. The nonsubstitutability of resources creates a conflict between private and public interests and calls for government intervention.
- C. The market system is the best system for overcoming the scarce resources-unlimited wants problem.
- D. Central direction by the government will improve resource allocation in a capitalistic economy.

AACSB: Analytic

Accessibility: Keyboard Navigation

Blooms: Remember

Difficulty: 1 Easy

63. The invisible hand refers to the:

- A. fact that the U.S. tax system redistributes income from rich to poor.
- B. notion that, under competition, decisions motivated by self-interest promote the social interest.
- C. tendency of monopolistic sellers to raise prices above competitive levels.
- D. fact that government controls the functioning of the market system.

AACSB:
Analytic

Accessibility: Keyboard
Navigation

Blooms:
Understand

Difficulty: 2
Medium

Learning Objective: 02-04 Explain the operation of the "invisible hand" and why market economies usually do a better job than command economies at efficiently transforming economic resources into desirable output.

Topic: Invisible hand

64. The invisible hand concept suggests that:

- A. market failures imply the need for a national economic plan.
- B. big businesses are inherently more efficient than small businesses.
- C. the competitiveness of a capitalistic market economy invariably diminishes over time.
- D. assuming competition, private and public interests will coincide.

AACSB: Reflective Thinking

Accessibility: Keyboard Navigation

Blooms: Understand

Difficulty: 2 Medium

Learning Objective: 02-04 Explain the operation of the "invisible hand" and why market economies usually do a better job than command economies at efficiently transforming economic resources into desirable output.

Topic: Invisible hand

65. Two major virtues of the market system are that it:

- A. allocates resources efficiently and allows economic freedom.
- B. results in an equitable personal distribution of income and always maintains full employment.
- C. results in price level stability and a fair personal distribution of income.
- D. eliminates discrimination and minimizes environmental pollution.

AACSB: Reflective Thinking

Learning Objective: 02-04 Explain the operation of the "invisible hand" and why market economies usually do a better job than command economies at efficiently transforming economic resources into desirable output.

Topic: Invisible hand

66. The market system:

- A. produces considerable inefficiency in the use of scarce resources.
- B. effectively harnesses the incentives of workers and entrepreneurs.**
- C. is not consistent with freedom of choice in the long run.
- D. has slowly lost ground to emerging command systems.

AACSB: Reflective Thinking

Accessibility: Keyboard Navigation

Blooms: Understand

Difficulty: 2 Medium

Learning Objective: 02-04 Explain the operation of the "invisible hand" and why market economies usually do a better job than command economies at efficiently transforming economic resources into desirable output.

Topic: Invisible hand

67. According to the concept of the "invisible hand," if Susie opens and operates a profitable childcare center, then:

- A. government should regulate the business to ensure quality.
- B. the profit Susie earns indicates that she is overcharging for her services.
- C. she has served society's interests by providing a desired good or service.**
- D. this demonstrates that consumer sovereignty is not present in this market.

AACSB: Reflective Thinking

Accessibility: Keyboard Navigation

Blooms: Apply

Difficulty: 2 Medium

Learning Objective: 02-04 Explain the operation of the "invisible hand" and why market economies usually do a better job than command economies at efficiently transforming economic resources into desirable output.

Topic: Invisible hand

68. The invisible hand promotes society's interests because:

- A. individuals pursuing their self-interest will try to produce goods and services that people in society want and are willing to purchase.**
- B. individuals will produce goods for others out of concern for their fellow human beings.
- C. it makes sure that everyone wins from competition in the market.
- D. government regulation pushes business into producing the right mix of goods and services.

AACSB: Reflective Thinking

Accessibility: Keyboard Navigation

Blooms: Understand

Learning Objective: 02-04 Explain the operation of the "invisible hand" and why market economies usually do a better job than command economies at efficiently transforming economic resources into desirable output.

Topic: Invisible hand

69. The coordination problem in the centrally planned economies refers to the idea that:

- A. planners had to direct required inputs to each enterprise.
- B. the price level and the level of employment were inversely related.
- C. the immediate effect of more investment was less consumption.
- D. exports had to be equal to imports for a central plan to work.

AACSB:
Analytic

Accessibility: Keyboard
Navigation

Blooms:
Understand

Difficulty: 2
Medium

Learning Objective: 02-01 Differentiate between laissez-faire capitalism; the command system; and the market system. Learning Objective: 02-04 Explain the operation of the "invisible hand" and why market economies usually do a better job than command economies at efficiently transforming economic resources into desirable output. Topic: Demise of the command systems

70. "Under central planning, some group has to decide how to get the necessary inputs produced in the right amounts and delivered to the right places at the right time. This is a nearly impossible task without markets and profits." This quotation best identifies the:

- A. incentive problem under central planning.
- B. coordination problem under central planning.
- C. self-sufficiency dilemma under communism.
- D. resource overcommitment problem under communism.

AACSB: Reflective Thinking

Accessibility: Keyboard Navigation

Blooms: Apply

Difficulty: 2 Medium

Learning Objective: 02-01 Differentiate between laissez-faire capitalism; the command system; and the market system. Learning Objective: 02-04 Explain the operation of the "invisible hand" and why market economies usually do a better job than command economies at efficiently transforming economic resources into desirable output. Topic: Demise of the command systems

71. "Because the outputs of many industries are the inputs to other industries, the failure of any single industry to fulfill the output quantities specified in the central plan caused a chain reaction of adverse repercussions on production." This quotation best identifies the:

- A. incentive problem under central planning.
- B. self-sufficiency dilemma under communism.
- C. resource overcommitment problem under communism.
- D. coordination problem under central planning.

AACSB: Reflective Thinking
Accessibility: Keyboard Navigation
Blooms: Apply
Difficulty: 2 Medium

Learning Objective: 02-01 Differentiate between laissez-faire capitalism; the command system; and the market system. Learning Objective: 02-04 Explain the operation of the "invisible hand" and why market economies usually do a better job than command economies at efficiently transforming economic resources into desirable output. Topic: Demise of the command systems

72. The incentive problem under communist central planning refers to the idea that:

- A. planners had to direct required inputs to each enterprise.
- B. workers, managers, and entrepreneurs could not personally gain by responding to shortages or surpluses or by introducing new and improved products.
- C. the immediate effect of more investment was less consumption.
- D. exports had to be equal to imports for a central plan to work.

AACSB: Reflective Thinking
Accessibility: Keyboard Navigation
Blooms: Understand
Difficulty: 2 Medium

Learning Objective: 02-01 Differentiate between laissez-faire capitalism; the command system; and the market system. Learning Objective: 02-04 Explain the operation of the "invisible hand" and why market economies usually do a better job than command economies at efficiently transforming economic resources into desirable output. Topic: Demise of the command systems

73. Suppose that an individual sees a tremendous opportunity to produce and sell a new product but dismisses the idea because there is no way to exploit this opportunity for personal gain. This situation best identifies the:

- A. coordination problem under communist central planning.
- B. self-sufficiency dilemma under communism.
- C. asymmetric information problem under communism.
- D. incentive problem under communist central planning.

AACSB: Reflective Thinking
Accessibility: Keyboard Navigation
Blooms: Apply
Difficulty: 2 Medium

Learning Objective: 02-01 Differentiate between laissez-faire capitalism; the command system; and the market system. Learning Objective: 02-04 Explain the operation of the "invisible hand" and why market economies usually do a better job than command economies at efficiently transforming economic resources into desirable output. Topic: Demise of the command systems

74. Innovation lagged in the centrally planned economies because:

- A. there was too much domestic business competition.
- B. there was too much competition from foreign firms.
- C. enterprises resisted innovation in fear that their production targets would be raised.
- D. exports had to equal imports for the plan to work.

AACSB: Reflective Thinking
Accessibility: Keyboard Navigation
Blooms: Understand
Difficulty: 2 Medium

Learning Objective: 02-01 Differentiate between laissez-faire capitalism; the command system; and the market system. Learning Objective: 02-04 Explain the operation of the "invisible hand" and why market economies usually do a better job than command economies at efficiently transforming economic resources into desirable output. Topic: Demise of the command systems

75. The fact that the major indicator of enterprise success in the Soviet Union and pre-reform China was the quantity of output implied that:

- A. product quality was neglected.
- B. production costs were minimized.
- C. product-mix met consumer needs.
- D. technological advance was too rapid.

AACSB: Reflective Thinking
Accessibility: Keyboard Navigation
Blooms: Analyze
Difficulty: 3 Hard

Learning Objective: 02-01 Differentiate between laissez-faire capitalism; the command system; and the market system. Learning Objective: 02-04 Explain the operation of the "invisible hand" and why market economies usually do a better job than command economies at efficiently transforming economic resources into desirable output. Topic: Demise of the command systems

76. Enterprise managers and workers in the Soviet Union often resisted innovations in production methods because:

- A. production targets were often increased when innovation occurred.
- B. there was a chronic shortage of computers.
- C. workers could not be reallocated geographically.
- D. innovations ordinarily increased dependence on world markets.

AACSB: Reflective Thinking
Accessibility: Keyboard Navigation
Blooms: Remember
Difficulty: 1 Easy

Learning Objective: 02-01 Differentiate between laissez-faire capitalism; the command system; and the market system. Learning Objective: 02-04 Explain the operation of the "invisible hand" and why market

77. If products were in short or surplus supply in the Soviet Union:
- A. price and profit signals eliminated those shortages and surpluses.
 - B. price and profit signals intensified those shortages and surpluses.
 - C. **producers would not react because no price or profit signals occurred.**
 - D. the planners would immediately adjust production to achieve equilibrium.

AACSB: Reflective Thinking
Accessibility: Keyboard Navigation
Blooms: Remember
Difficulty: 1 Easy

Learning Objective: 02-01 Differentiate between laissez-faire capitalism; the command system; and the market system. Learning Objective: 02-04 Explain the operation of the "invisible hand" and why market economies usually do a better job than command economies at efficiently transforming economic resources into desirable output. Topic: Demise of the command systems

78. In what type of business do the owners bear no personal financial responsibility for the company's debts and obligations?
- A. Partnerships.
 - B. **Corporations.**
 - C. Sole proprietorships.
 - D. In all of the businesses listed in the other answers.

AACSB: Analytic
Accessibility: Keyboard Navigation
Blooms: Remember
Difficulty: 1 Easy

Learning Objective: 02-05 Describe the mechanics of the circular flow model.

Topic: Circular flow model

79. The simple circular flow model shows that:
- A. households are on the buying side of both product and resource markets.
 - B. businesses are on the selling side of both product and resource markets.
 - C. **households are on the selling side of the resource market and on the buying side of the product market.**
 - D. businesses are on the buying side of the product market and on the selling side of the resource market.

AACSB: Analytic
Accessibility: Keyboard Navigation
Blooms: Remember
Difficulty: 1 Easy

Learning Objective: 02-05 Describe the mechanics of the circular flow model.

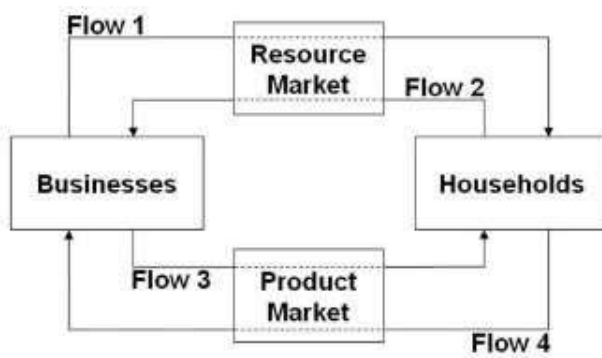

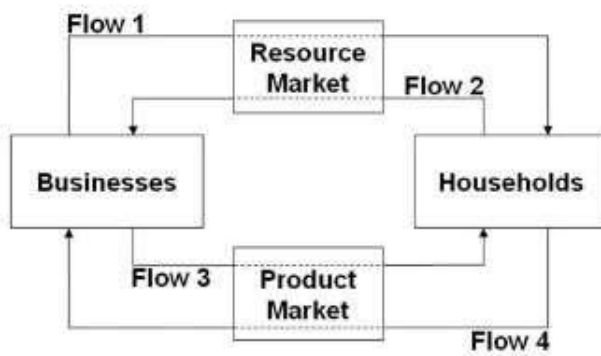
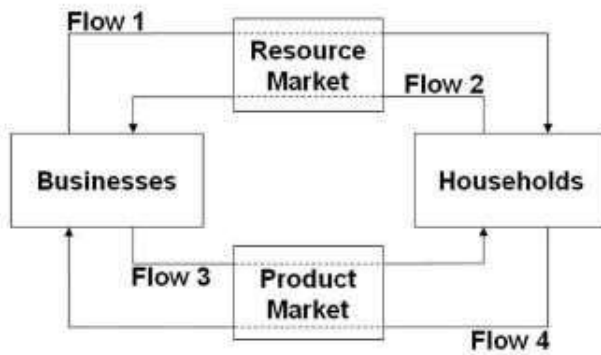

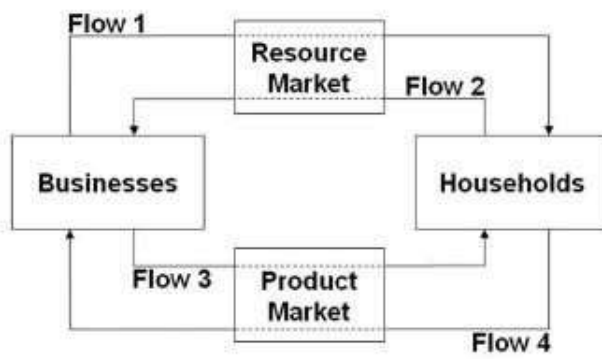

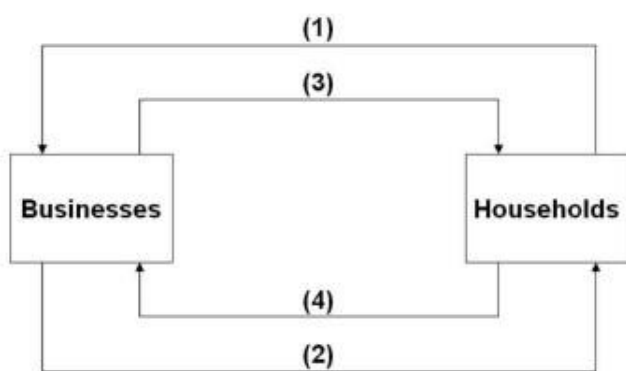

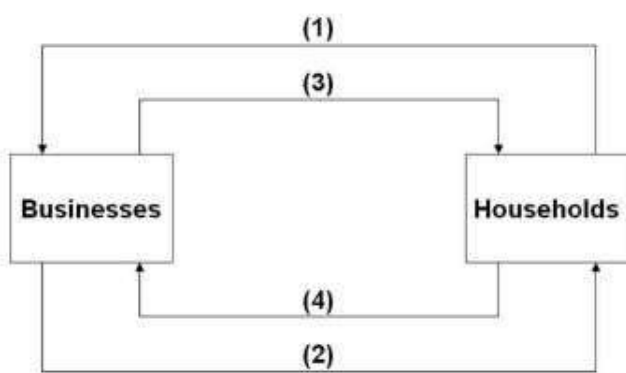
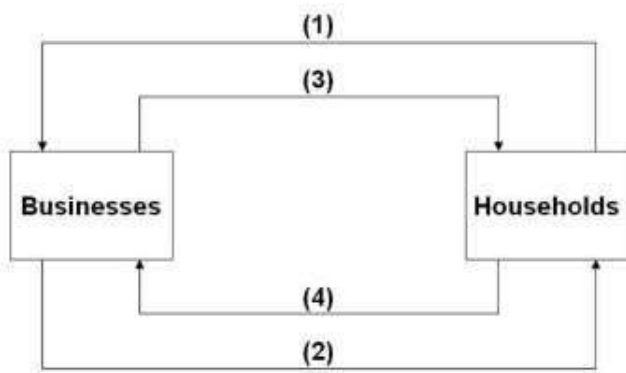

Refer to the diagram. Arrows (1) and (2) represent:

Refer to the diagram. Arrows (1) and (3) are associated with:

- A. goods and resources respectively.
- B. money incomes and output respectively.
- ~~A. the money market.~~
- ~~C. output and money incomes respectively.~~
- B. the resource market.**
- C. the product market.
- D. international trade.

AACSB: Analytic

Blooms: Remember

Difficulty: 1 Easy

AACSB: Analytic

Learning Objective: 02-05 Describe the mechanics of the circular flow model.

Blooms: Remember

Topic: Circular flow model

Difficulty: 1 Easy

Learning Objective: 02-05 Describe the mechanics of the circular flow model.

Type: Figure

Topic: Circular flow model

Type: Figure

93. Which of the following best illustrates the circular flow model in action?

- A. Bobbie goes to work and builds cars, and uses the income she receives to buy food at the grocery store.
- B. Evan buys a new couch; the owner of the furniture store uses some of the money from the sale to pay her supplier, and uses the rest to take her family out to dinner.
- C. Boeing experiences a surge in orders for new airplanes, prompting the company to hire more workers.

Refer to the diagram. Arrows (3) and (4) represent the circular flow model.

AACSB: Reflective Thinking

Accessibility: Keyboard Navigation

Blooms: Apply

Difficulty: 2 Medium

- A. goods and services respectively.
- B. incomes and consumer expenditures respectively.**
- C. resources and goods respectively.
- D. consumer expenditures and income respectively.

Learning Objective: 02-05 Describe the mechanics of the circular flow model.

Topic: Circular flow model

Blooms: Remember

Difficulty: 1 Easy

94. Risk is a problem faced:

Learning Objective: 02-05 Describe the mechanics of the circular flow model.

Topic: Circular flow model

Type: Figure

- A. only in market systems.
- B. only in command systems.

C. in both market systems and command systems.

irecapitalism.

D. in neither of these markets systems, only in laissez-faire

Learning Objective: 02-06 Explain how the market system deals with risk.

Topic: Risk

95. Which of the following statements is true about risk management in market systems versus command systems?

A. Market systems manage risk better because entrepreneurs taking risks bear the costs of poor decisions, where in command systems government decision makers don't bear those costs.

B. Neither system is better than the other in terms of risk management; both systems are equally susceptible to natural disasters and changes in consumer preferences.

C. Command systems manage risk better because the government controls most economic activity and can therefore eliminate risk.

D. Market systems face risk because of the possibility of profits and losses; command systems don't face risk because they are not profit driven.

Learning Objective: 02-06 Explain how the market system deals with risk.

Topic: Risk

96. Risk management in command economies:

A. is easy because there is no risk.

B. is easy because the government controls most activity and can eliminate risk.

C. tends to be done poorly because government officials do not understand risk.

D. tends to be done poorly because decision makers are insulated from the risk of making a poor decision.

Learning Objective: 02-06 Explain how the market system deals with risk.

Topic: Risk

97. In a market system:

A. firm owners and employees share business risk more or less equally.

B. a firm's employees and suppliers are largely shielded from risk.

C. employees and suppliers face the greatest risks because firms can shut down without notice and leave them unpaid.

D. a firm's owners are largely shielded from risk because they can walk away from the business at any time.

AACSB: Analytic

Accessibility: Keyboard Navigation

Blooms: Understand

Difficulty: 2 Medium

Learning Objective: 02-06 Explain how the market system deals with risk.

Topic: Risk

98. In a market system, employees and suppliers:

A. are usually shielded from risk, but at the cost of not sharing in the profits of the firm.

B. are usually shielded from risk and share in the profits of the firm.

C. are generally subject to as much risk as firm owners but get to share in the profits.

D. bear as much risk as firm owners but don't get to share in the profits.

AACSB: Analytic

Accessibility: Keyboard Navigation

Blooms: Understand

Difficulty: 2 Medium

Learning Objective: 02-06 Explain how the market system deals with risk.

Topic: Risk

99. A market system tends to restrict business risk to owners and investors. This results in which of the following benefits?

A. A more stable macroeconomy with fewer recessions.

B. Firms are better able to attract inputs, as these inputs do not have to share the risk.

C. Government agencies are better prepared to help when businesses fail.

D. Consistently lower prices for consumers.

AACSB: Analytic

Accessibility: Keyboard Navigation

Blooms: Understand

Difficulty: 2 Medium

Learning Objective: 02-06 Explain how the market system deals with risk.

Topic: Risk

100. A market system tends to restrict business risk to owners and investors. This results in which of the following benefits?

A. It encourages more people to become entrepreneurs.

B. Firms have to pay more to attract inputs, as these inputs have to share the risk.

C. Firms focus attention on prudent risk management, as it is profitable to manage risk.

D. Income becomes more equally distributed.

AACSB: Analytic

Accessibility: Keyboard Navigation

Blooms: Understand

Difficulty: 2 Medium

Learning Objective: 02-06 Explain how the market system deals with risk.

Topic: Risk

101. (Consider This) In 1975, McDonald's introduced its Egg McMuffin breakfast sandwich, which remains popular and profitable today. This longevity illustrates the idea of:

A. opportunity cost.

B. upsloping supply.

C. consumer sovereignty.

D. specialization.

AACSB: Reflective Thinking

Accessibility: Keyboard Navigation

Blooms: Apply

Difficulty: 2 Medium

Learning Objective: 02-03 Explain how the market system answers the five fundamental questions of what to produce; how to produce; who obtains the output; how to adjust to change; and how to promote progress. Topic: Five fundamental questions

102. (Consider This) In 2000, McDonald's introduced its McSalad Shaker, which failed to catch on with the public and was subsequently dropped from the menu. This failure illustrates the idea of:

A. consumer sovereignty.

B. technological change.

C. downsloping demand.

D. specialization.

AACSB: Reflective Thinking

Accessibility: Keyboard Navigation

Blooms: Apply

Difficulty: 2 Medium

Learning Objective: 02-03 Explain how the market system answers the five fundamental questions of what to produce; how to produce; who obtains the output; how to adjust to change; and how to promote progress. Topic: Five fundamental questions

103. (Consider This) Since World War II:

A. North Korea's command economy has significantly outperformed South Korea's market economy.

B. South Korea's command economy has significantly outperformed North Korea's market economy.

C. North Korea's market economy has significantly outperformed South Korea's command economy.

D. South Korea's market economy has significantly outperformed North Korea's command economy.

AACSB: Analytic

Accessibility: Keyboard Navigation

Blooms: Remember

Difficulty: 1 Easy

Learning Objective: 02-01 Differentiate between laissez-faire capitalism; the command system; and the market system. Learning Objective: 02-04 Explain the operation of the "invisible hand" and why market economies usually do a better job than command economies at efficiently transforming economic resources into desirable output. Topic: Demise of the command systems

104. (Consider This) North Korea's command economy:

A. is one of the few remaining command economies.

B. has grown much faster than South Korea's economy since the two countries were divided after World War II.

C. produces a per capita GDP of nearly \$25,000.

D. has undergone significant market reforms and is now one of the fastest-growing economies.

AACSB: Analytic

Accessibility: Keyboard Navigation

Blooms: Remember

Difficulty: 1 Easy

Learning Objective: 02-01 Differentiate between laissez-faire capitalism; the command system; and the market system. Learning Objective: 02-04 Explain the operation of the "invisible hand" and why market economies usually do a better job than command economies at efficiently transforming economic resources into desirable output. Topic: Demise of the command systems

105. (Consider This) Which of the following statements about insurance and risk is true?

A. Insurance inhibits economic growth and investment by discouraging risk-taking.

B. Insurance transfers risk from those with a high tolerance for risk to those with a low tolerance for risk.

C. Insurance companies always earn profits because insurance premiums always exceed the payout for insured events.

D. Insurance transfers risk from those with a low tolerance for risk to those with a higher tolerance for risk.

AACSB: Analytic

Accessibility: Keyboard Navigation

Blooms: Understand

Difficulty: 2 Medium

Learning Objective: 02-06 Explain how the market system deals with risk.

Topic: Risk

106. (Consider This) Martha's Milkshake Company buys earthquake insurance from the Stable Ground Insurance Company. Based on this purchase, economists would conclude that:

- A. Martha's believes a damaging earthquake is imminent.
- B. Stable Ground believes no damaging earthquakes will occur.
- C. Martha's has a lower tolerance for earthquake risk than Stable Ground.
- D. Martha's has a greater tolerance for earthquake risk than Stable Ground.

AACSB: Analytic

Accessibility: Keyboard Navigation

Blooms: Apply

Difficulty: 2 Medium

Learning Objective: 02-06 Explain how the market system deals with risk.

Topic: Risk

107. (Last Word) According to economist Donald Boudreaux, the world's tens of billions of individual resources get arranged productively:

- A. because government has become highly effective at central planning.
- B. because private property encourages people to consider the alternative uses of their resources and select those that provide the most rewards.
- C. because people tend to be creative and orderly.
- D. through random trial and error.

AACSB: Analytic

Accessibility: Keyboard Navigation

Blooms: Understand

Difficulty: 2 Medium

Learning Objective: 02-02 List the main characteristics of the market system.

Topic: Characteristics of the market system

108. (Last Word) According to economist Donald Boudreaux:

- A. private property eliminates the possibility that resource arrangements will be random.
- B. the market system threatens to do irreparable harm to the world's ecosystem.
- C. arranging resources under the market system is much like shuffling a deck of cards.
- D. the market system works wondrously for advanced industrial nations but not for developing nations.

AACSB: Analytic

Accessibility: Keyboard Navigation

Blooms: Understand

Difficulty: 2 Medium

Learning Objective: 02-02 List the main characteristics of the market system.

Topic: Characteristics of the market system

—

—

—

—

—

—

—

—

Learning Objective: 02-03 Explain how the market system answers the five fundamental questions of what to produce; how to produce; who obtains the output; how to adjust to change; and how to promote progress. Topic: Five fundamental questions

113. The wants of consumers are expressed in the product market with dollar votes.

TRUE

117. The invisible hand refers to the many indirect controls that the federal government imposes in a market system.

AACSB: Analytic

Accessibility: Keyboard Navigation

Blooms: Remember

Difficulty: 1 Easy

FALSE

Learning Objective: 02-03 Explain how the market system answers the five fundamental questions of what to produce; how to produce; who obtains the output; how to adjust to change; and how to promote progress. Topic: Five fundamental questions

AACSB: Analytic

Accessibility: Keyboard Navigation

Blooms: Understand

Difficulty: 2 Medium

114. Cost is defined as total payments made to workers, land owners, and less payments to the entrepreneur for organizing and other resources used to produce a good.

Learning Objective: 02-04 Explain the operation of the "invisible hand" and why market economies usually do a better job than command economies at efficiently transforming economic resources into desirable output.

Topic: Invisible hand

AACSB: Analytic

118. Central planning in the Soviet Union and pre-reform China emphasized the expansion of the production of consumer goods to raise the domestic standard of living.

Accessibility: Keyboard Navigation

Blooms: Remember

Difficulty: 1 Easy

Learning Objective: 02-03 Explain how the market system answers the five fundamental questions of what to produce; how to produce; who obtains the output; how to adjust to change; and how to promote progress. Topic: Five fundamental questions

FALSE

115. Corrupt practices in an industry will cause some firms to reduce output or the industry.

AACSB: Reflective Thinking

Accessibility: Keyboard Navigation

Blooms: Remember

Difficulty: 1 Easy

Learning Objective: 02-01 Differentiate between laissez-faire capitalism; the command system; and the market system. Learning Objective: 02-04 Explain the operation of the "invisible hand" and why market economies usually do a better job than command economies at efficiently transforming economic resources into desirable output. Topic: Demise of the command systems

AACSB: Analytic

Accessibility: Keyboard Navigation

119. Central planning often suffers from a coordination problem and an incentive problem.

Blooms: Understand

Difficulty: 2 Medium

TRUE

Learning Objective: 02-03 Explain how the market system answers the five fundamental questions of what to produce; how to produce; who obtains the output; how to adjust to change; and how to promote progress. Topic: Five fundamental questions

AACSB: Reflective Thinking

Accessibility: Keyboard Navigation

Blooms: Remember

Difficulty: 1 Easy

116. The guiding function of prices tends to keep resources flowing toward their most highly valued uses.

Learning Objective: 02-01 Differentiate between laissez-faire capitalism; the command system; and the market system. Learning Objective: 02-04 Explain the operation of the "invisible hand" and why market economies usually do a better job than command economies at efficiently transforming economic resources into desirable output. Topic: Demise of the command systems

TRUE

AACSB: Analytic

Accessibility: Keyboard Navigation

Blooms: Understand