

Test Bank for Essentials of College Algebra 11th Edition by Lial Hornsby Schneider Daniels ISBN 032191225X 9780321912251

Test bank:

<https://testbankpack.com/p/test-bank-for-essentials-of-college-algebra-11th-edition-by-lial-hornsby-schneider-daniels-isbn-032191225x-9780321912251/>

Solution manual:

<https://testbankpack.com/p/solution-manual-for-essentials-of-college-algebra-11th-edition-by-lial-hornsby-schneider-daniels-isbn-032191225x-9780321912251/>

MULTIPLE CHOICE. Choose the one alternative that best completes the statement or answers the question.

List the ordered pairs from the table.

1)

x	y
4	-9
5	-12
7	-18
8	-21

- A) (4, -9), (5, -12), (7, -18), (8, -21)
- B) (4, -21), (5, -18), (7, -12), (8, -9)
- C) (4, -12), (5, -9), (7, -21), (8, -18)
- D) (-9, 4), (-12, 5), (-18, 7), (-21, 8)

Answer: A

2)

Sales at the University Bookstore

Month	Sales
1	\$500,000
2	\$220,000
3	\$1,190,000
4	\$420,000

- A) (1, 220,000), (2, 500,000), (3, 420,000), (4, 1,190,000)
- B) (420,000, 1), (1,190,000, 2), (220,000, 3), (500,000, 4)
- C) (500,000, 1), (220,000, 2), (1,190,000, 3), (420,000, 4)
- D) (1, 500,000), (2, 220,000), (3, 1,190,000), (4, 420,000)

Answer: D

For the points P and Q, find the distance $d(P, Q)$.

3) P(2, 5), Q(-1, -3)

- A) -5
- B) $\sqrt{73}$
- C) $\sqrt{55}$
- D) 24

Answer: B

4) P(3, -5), Q(5, -1)

- A) 2

B) $12\sqrt{3}$

C) $2\sqrt{5}$

D) 12

Answer: C

5) P(-6, -1), Q(6, 3)

A) $128\sqrt{2}$

B) $4\sqrt{10}$

C) 128

D) 8

Answer: B

6) $P(4, 5), Q(-1, -5)$

A) $5\sqrt{5}$

B) 75

C) $75\sqrt{3}$

D) 5

Answer: A

7) $P(5\sqrt{7}, -3\sqrt{11}), Q(9\sqrt{7}, -2\sqrt{11})$

A) $\sqrt{-17}$

B) $\sqrt{123}$

C) -17

D) 123

Answer: B

For the points P and Q, find the coordinates of the midpoint of the segment PQ.

8) $P(7, 4), Q(1, 5)$

A) $\left(3, -\frac{1}{2}\right)$

B) $\left(4, \frac{9}{2}\right)$

C) (6, -1)

D) (8, 9)

Answer: B

9) $P(6, -4), Q(-7, 7)$

A) $\left(\frac{13}{2}, -\frac{11}{2}\right)$

B) (13, -11)

C) (-1, 3)

D) $\left(-\frac{1}{2}, \frac{3}{2}\right)$

Answer: D

10) $P(-6, -9), Q(9, 0)$

A) $\left(-\frac{15}{2}, -\frac{9}{2}\right)$

B) $\left(\frac{3}{2}, -\frac{9}{2}\right)$

C) (-15, -9)

D) (3, -9)

Answer: B

11) P(-1, 8), Q(-3, 5)

A) (2, 3)

B) (-4, 13)

C) $\left(-2, \frac{13}{2}\right)$

D) $\left(1, \frac{3}{2}\right)$

Answer: C

12) P($9\sqrt{5}$, $-\sqrt{10}$), Q($-\sqrt{5}$, 0)

A) $\left(5\sqrt{5}, \frac{\sqrt{10}}{2}\right)$

B) $\left(4\sqrt{10}, -\frac{\sqrt{30}}{2}\right)$

C) $\left(4\sqrt{5}, -\frac{\sqrt{10}}{2}\right)$

D) (-5, 10)

Answer: C

13) P($9\sqrt{7}$, $\sqrt{13}$), Q($-\sqrt{7}$, $4\sqrt{13}$)

A) $\left(5\sqrt{7}, \frac{\sqrt{13}}{2}\right)$

B) $\left(4\sqrt{7}, \frac{5\sqrt{13}}{2}\right)$

C) $\left(4\sqrt{7}, 5\sqrt{13}\right)$

D) $\left(4\sqrt{14}, -\frac{\sqrt{39}}{2}\right)$

Answer: B

14) P($-\sqrt{2}$, 1), Q(0, $\sqrt{7}$)

A) $\left(\frac{-\sqrt{2} + \sqrt{7}}{2}, \frac{1}{2}\right)$

B) $(-\sqrt{2}, 1 + \sqrt{7})$

C) $\left(\frac{\sqrt{2}}{2}, \frac{1 - \sqrt{7}}{2}\right)$

D) $\left(-\frac{\sqrt{2}}{2}, \frac{1 + \sqrt{7}}{2}\right)$

Answer: D

Determine whether the three points are the vertices of a right triangle.

15) (6, -6), (9, -6), (9, 1)

A) Yes

B) No

Answer: A

16) $(-5, 3), (-3, 7), (-1, 6)$

A) Yes

B) No

Answer: A

17) $(1, 4), (7, 6), (11, -6)$

A) Yes

B) No

Answer: A

18) $(7, 0), (13, 2), (12, -3)$

A) Yes

B) No

Answer: B

19) $(2, 6), (8, 8), (14, 1)$

A) Yes

B) No

Answer: B

20) $(-11, 6), (0, -5), (2, -3)$

A) Yes

B) No

Answer: A

Determine whether the three points are collinear.

21) $(-14, -9), (-8, -5), (-20, -13)$

A) Yes

B) No

Answer: A

22) $(3, -10), (-2, -7), (0, -5)$

A) Yes

B) No

Answer: B

23) $(-1, -3), (1, 1), (9, 17)$

A) Yes

B) No

Answer: A

24) $(7, -3), (-2, 5), (1, 1)$

A) Yes

B) No

Answer: B

Find the coordinates of the other endpoint of the segment, given its midpoint and one endpoint.

25) midpoint (-1, 9), endpoint (-4, 5)

- A) (2, 13)
- B) (2, 1)
- C) (4, 11)
- D) (-10, -3)

Answer: A

26) midpoint (-2, 1), endpoint (3, 2)

- A) (1, -8)
- B) (13, 4)
- C) (-7, 0)
- D) (-7, 3)

Answer: C

27) midpoint (13, 1), endpoint (10, 5)

- A) (4, 13)
- B) (2, 11)
- C) (16, 9)
- D) (16, -3)

Answer: D

28) midpoint (-1, -8), endpoint (3, -10)

- A) (-5, -12)
- B) (11, -14)
- C) (7, -18)
- D) (-5, -6)

Answer: D

29) midpoint (d, y), endpoint (m, q)

- A) (d - m, y - q)
- B) (2m - d, 2q - y)
- C) $\left(\frac{d+m}{2}, \frac{y+q}{2}\right)$
- D) (2d - m, 2y - q)

Answer: D

30) midpoint $\left(\frac{p+d}{2}, \frac{q-w}{2}\right)$, endpoint (p, q)

- A) $\left(\frac{d}{2}, -\frac{w}{2}\right)$
- B) (d, -w)
- C) (d, w)
- D) $\left(\frac{3p+d}{4}, \frac{3q-w}{4}\right)$

Answer: B

Solve the problem.

- 31) The graph shows an idealized linear relationship for the average monthly payment to retirees from 1995 to 1999. Use the midpoint formula to estimate the average payment in 1997.

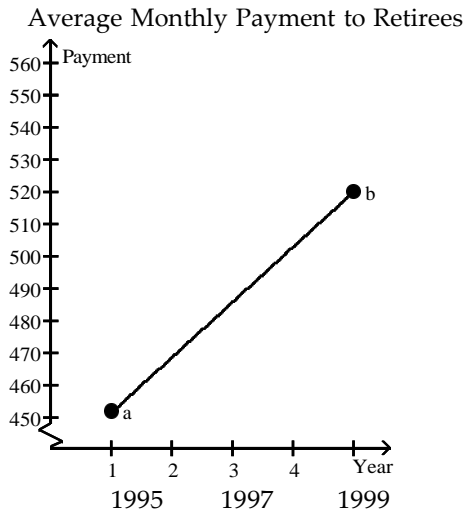

$a = \$452$; $b = \$520$

- A) \$34
- B) \$500
- C) \$520
- D) \$486

Answer: D

- 32) The table lists how financial aid income cutoffs (in dollars) for a family of four have changed over time. Use the midpoint formula to approximate the financial aid cutoff for 1985.

Year	Income (in dollars)
1960	21,000
1970	27,000
1980	33,000
1990	39,000
2000	45,000

- A) \$18,000
- B) \$57,000
- C) \$36,000
- D) \$21,000

Answer: C

33) The table shows enrollment in 2-year technical schools for 1980, 1990 and 2000. Assuming a linear relationship, estimate the enrollment for 1995.

Year	Enrollment (in millions)
1980	2.4
1990	3.1
2000	3.8

- A) 3.45 million
- B) 1.75 million
- C) 2.4 million
- D) 5.15 million

Answer: A

Graph the equation by determining the missing values needed to plot the ordered pairs.

34) $y + x = 4$; (1,), (4,), (3,)

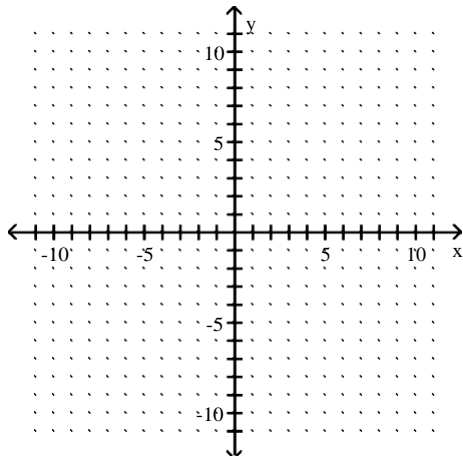

A)

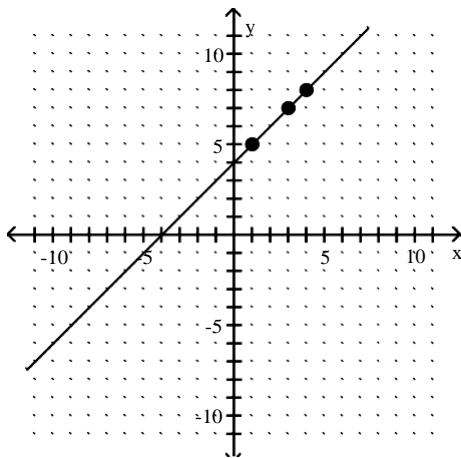

B)

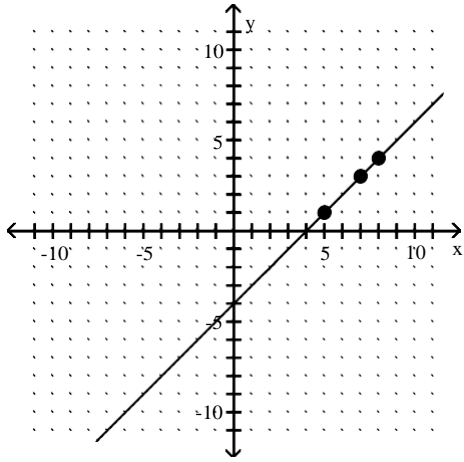

C)

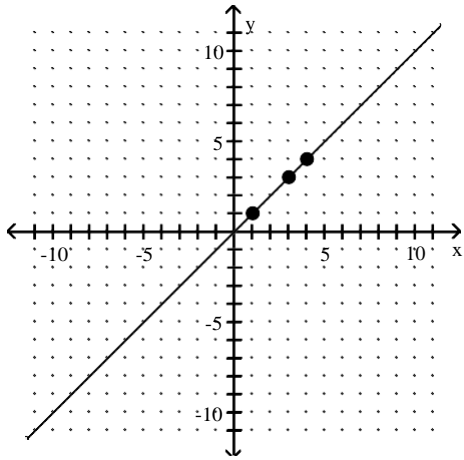

D)

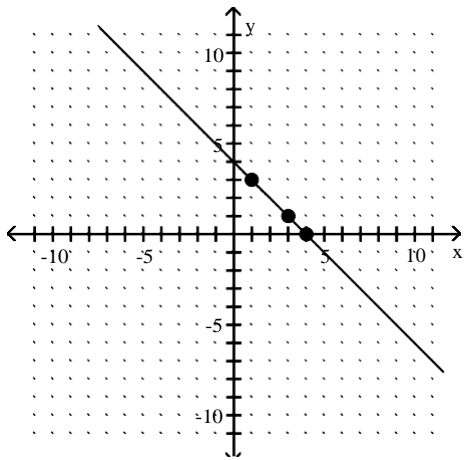

Answer: D

35) $y - x = -1$; (4,), (, 6), (3,)

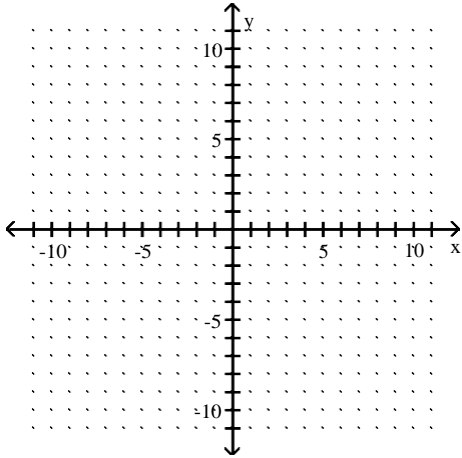

A)

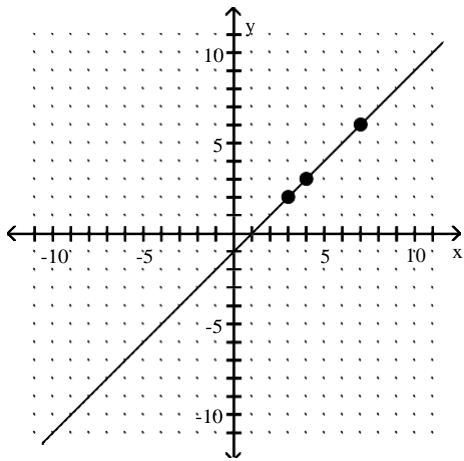

B)

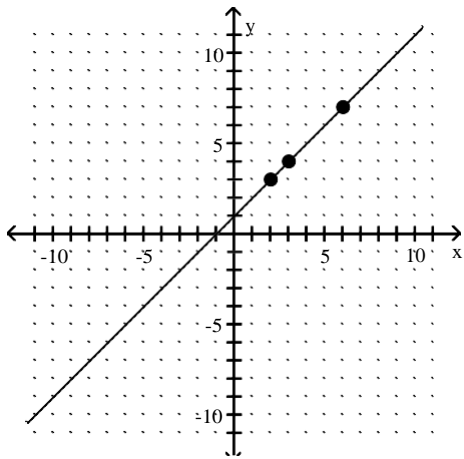

C)

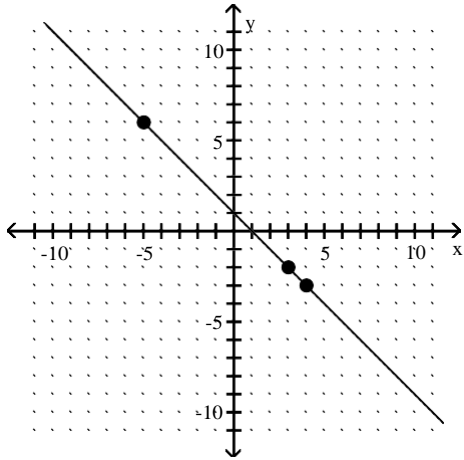

D)

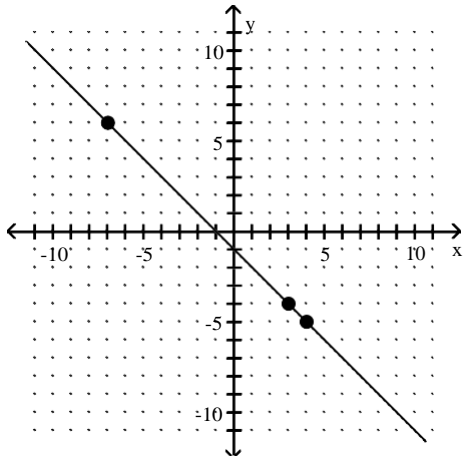

Answer: A

36) $x - 2y = -8$; $(0, \quad)$, $(\quad, 0)$, $(3, \quad)$, $(\quad, 3)$

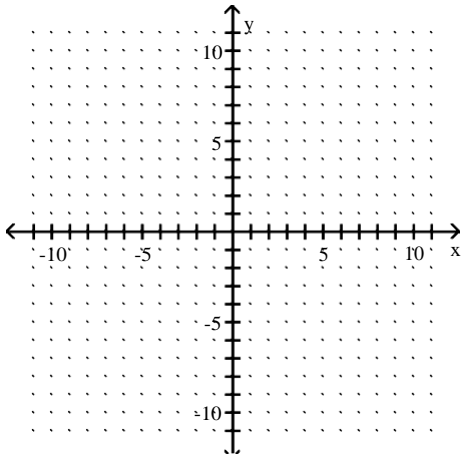

A)

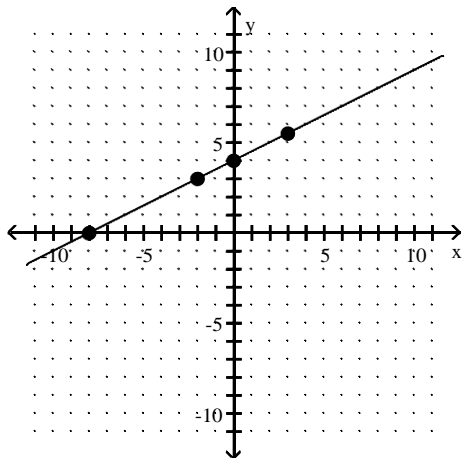

B)

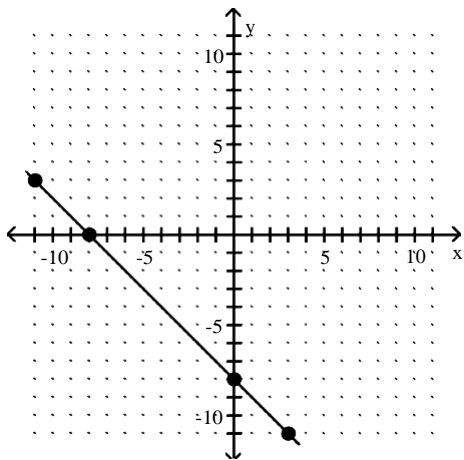

C)

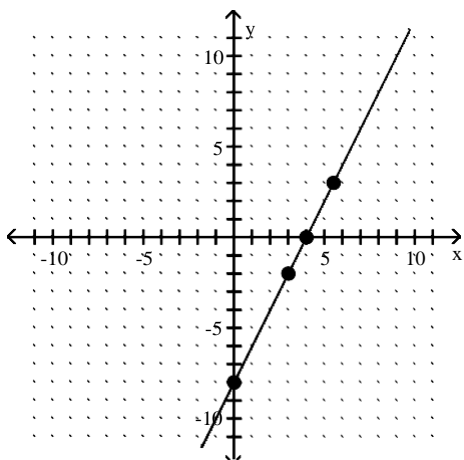

D)

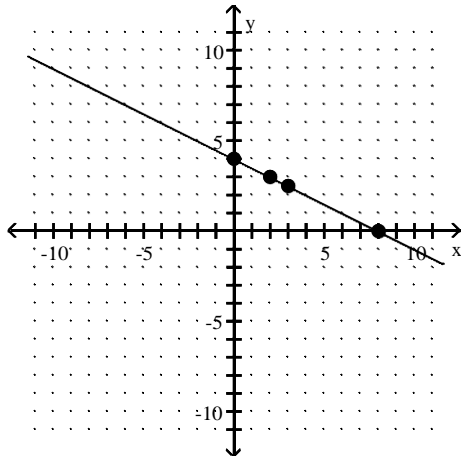

Answer: A

37) $5x - 6y = -30$; $(0, \quad)$, $(\quad, 0)$, $(-1, \quad)$

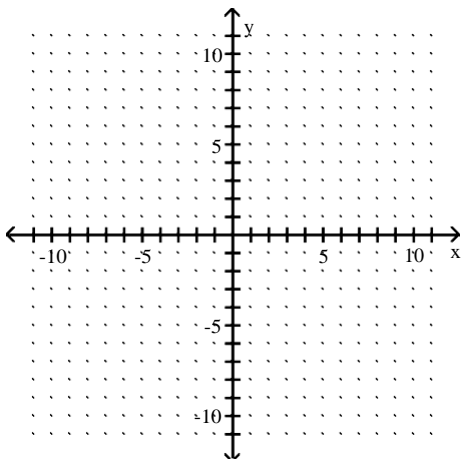

A)

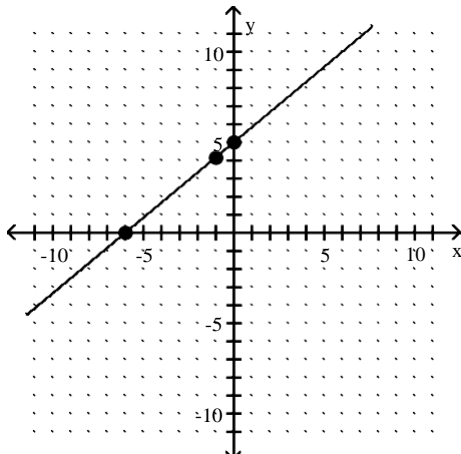

B)

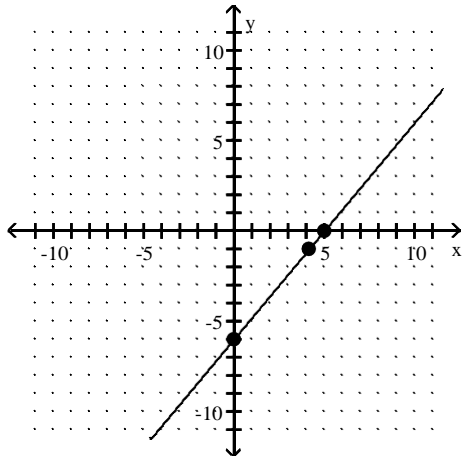

C)

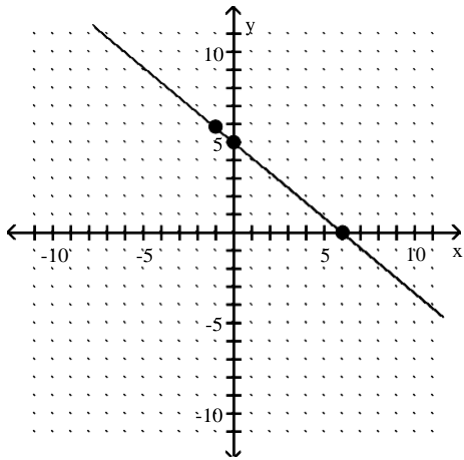

D)

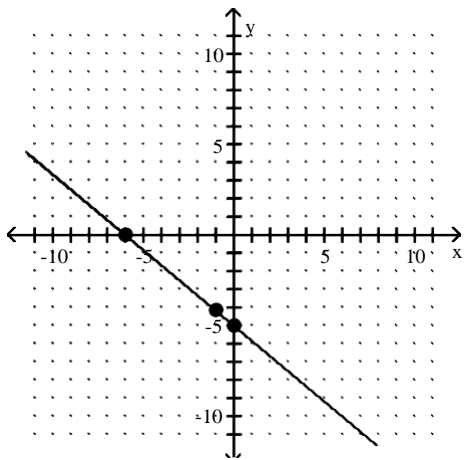

Answer: A

38) $4y = -2x + 8$; $(0, \quad)$, $(\quad, 0)$, $(1, \quad)$

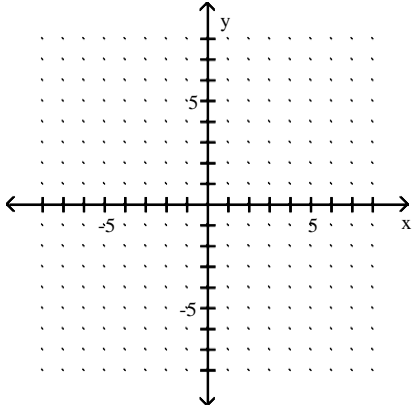

A)

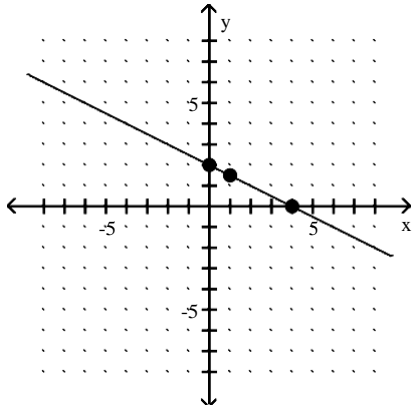

B)

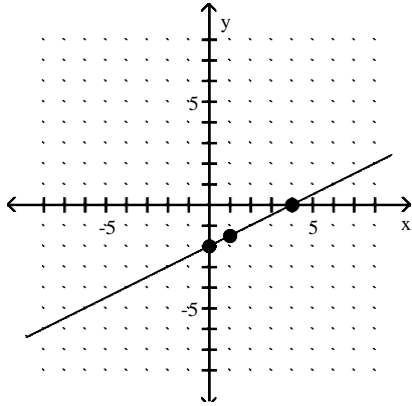

C)

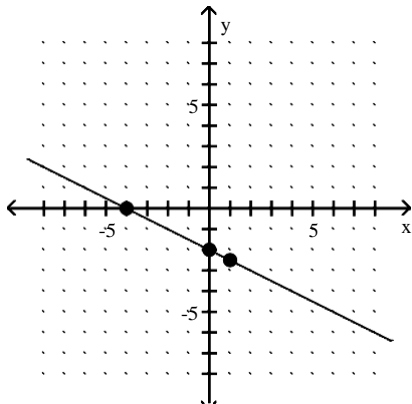

D)

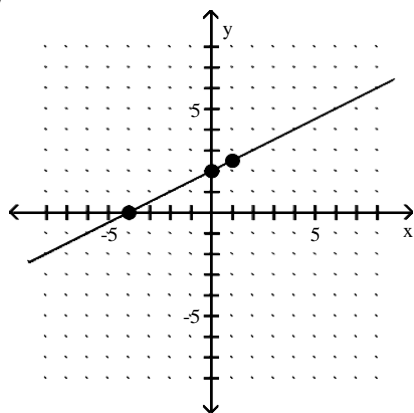

Answer: A

Graph the equation by plotting points.

39) $y = \sqrt{x - 6}$

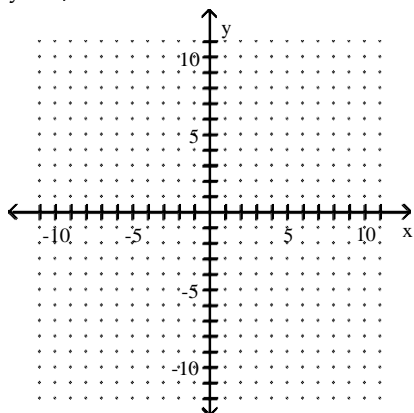

A)

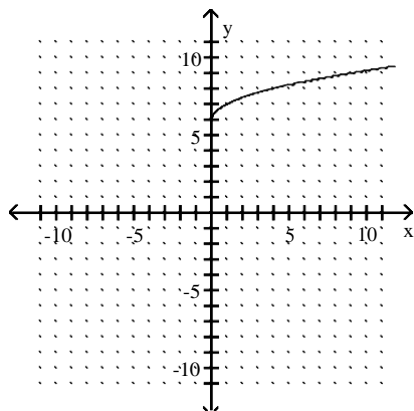

B)

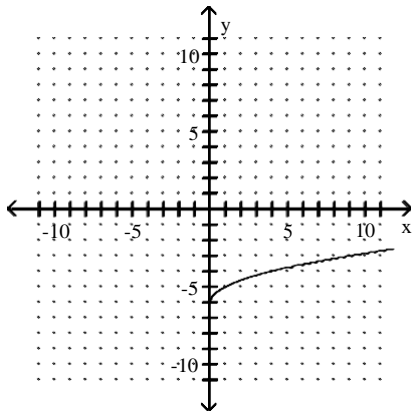

C)

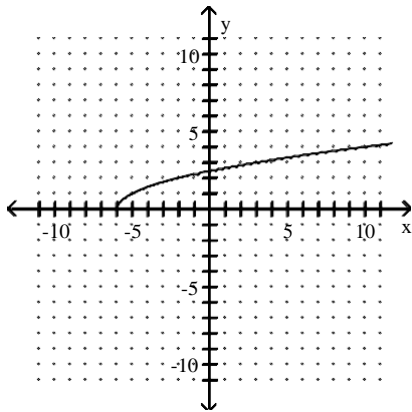

D)

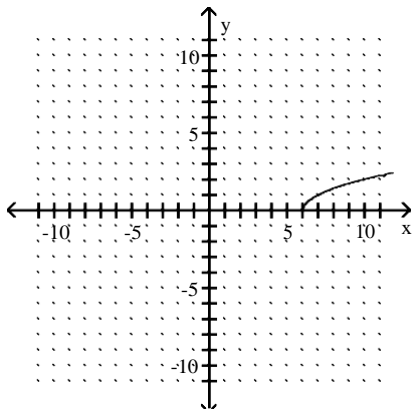

Answer: D

40) $y = \sqrt{x} - 5$

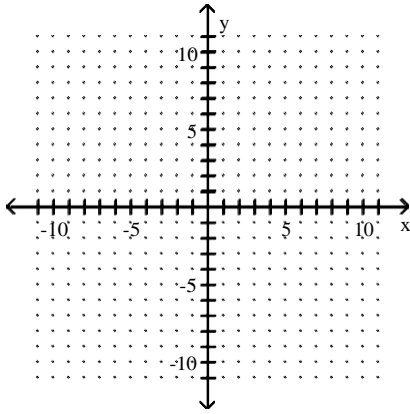

A)

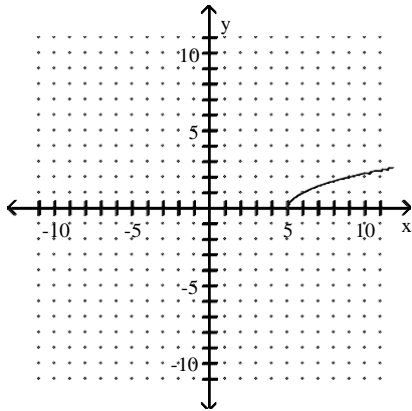

B)

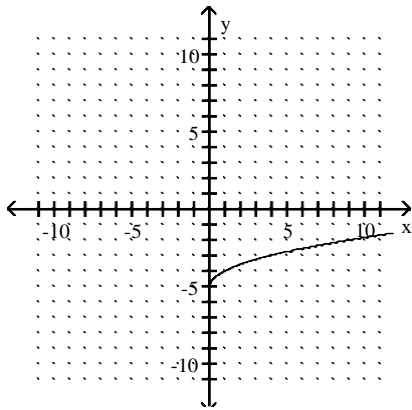

C)

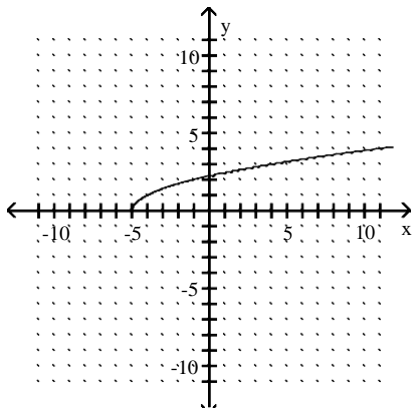

D)

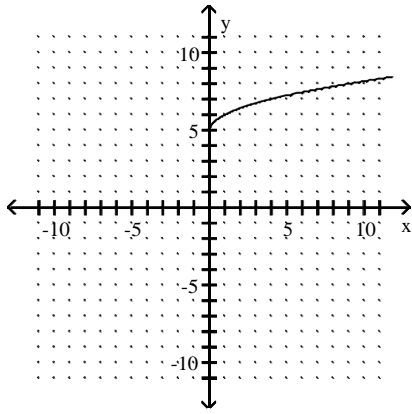

Answer: B

41) $y = x^2 + 5$

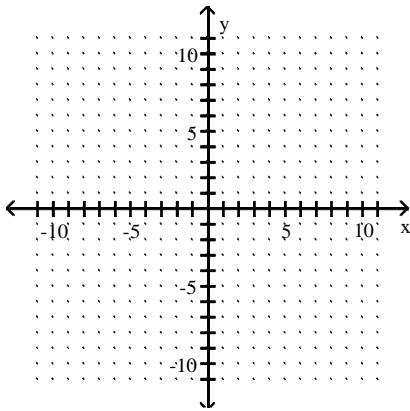

A)

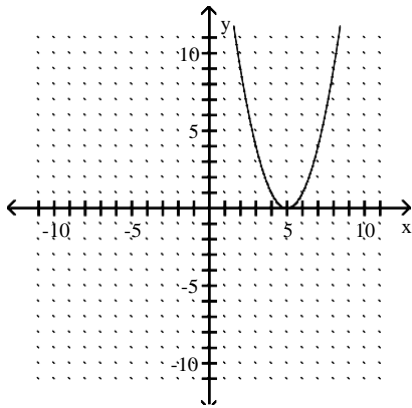

B)

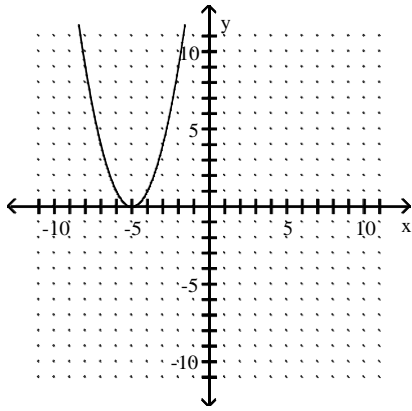

C)

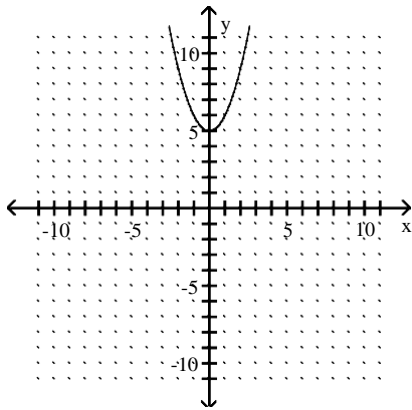

D)

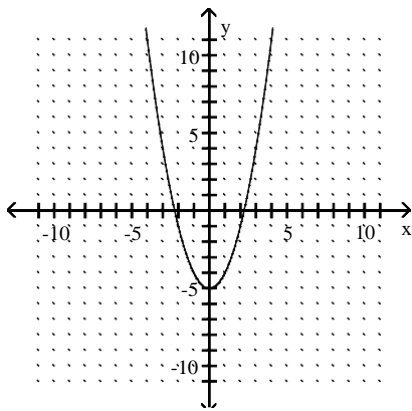

Answer: C

42) $y = |-4 - x|$

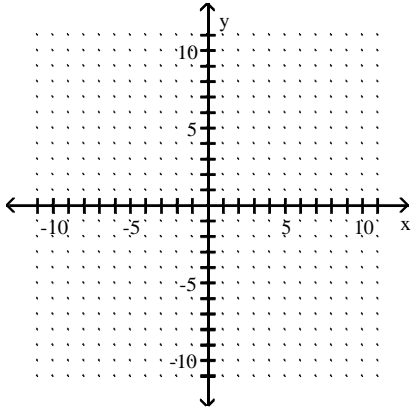

A)

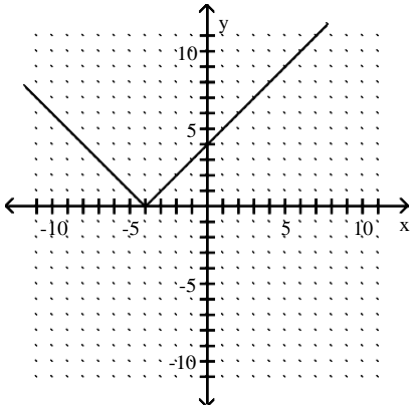

B)

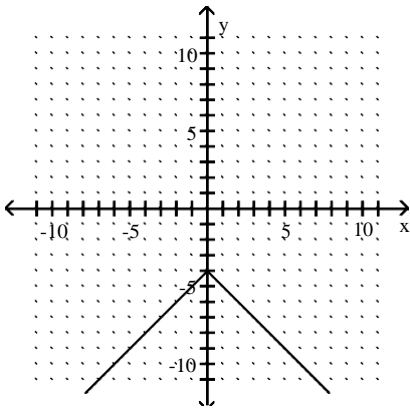

C)

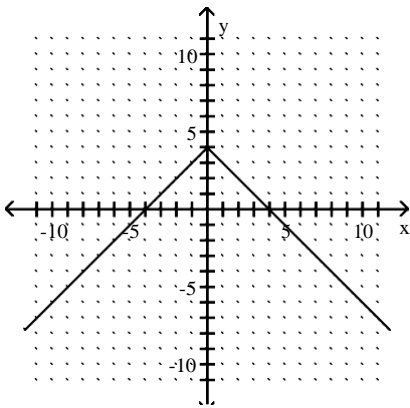

D)

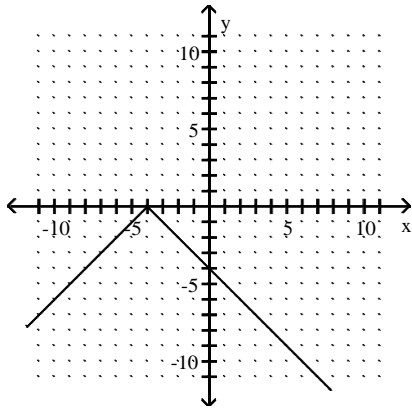

Answer: A

43) $y = |x| + 2$

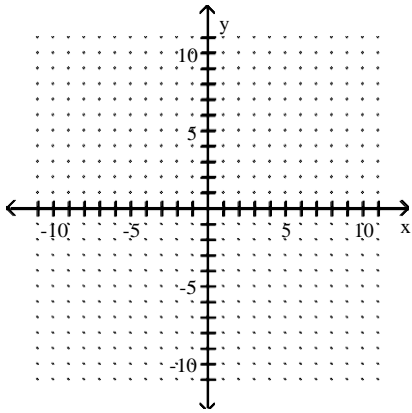

A)

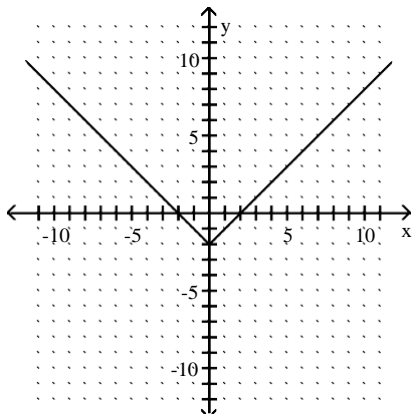

B)

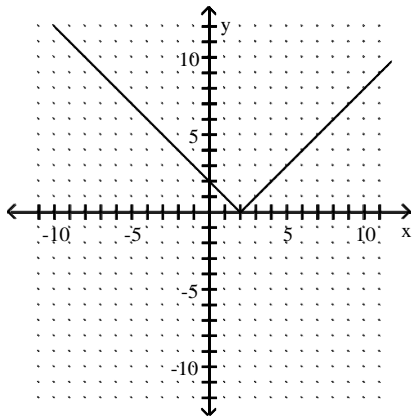

C)

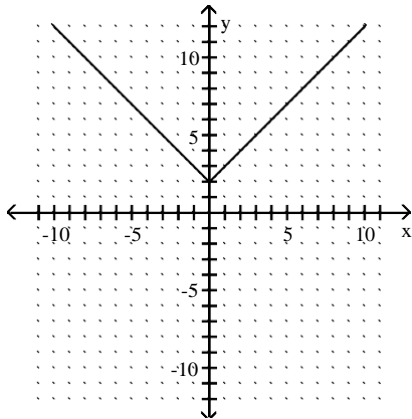

D)

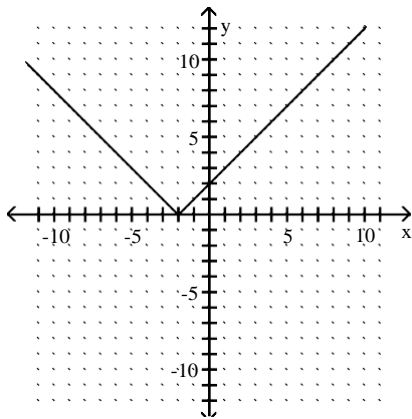

Answer: C

44) $y = -x^2 + 2$

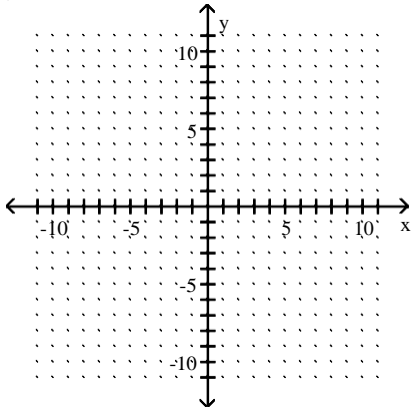

A)

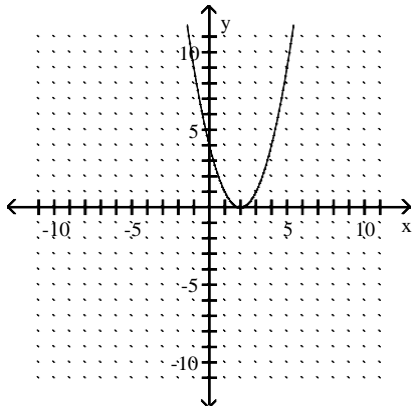

B)

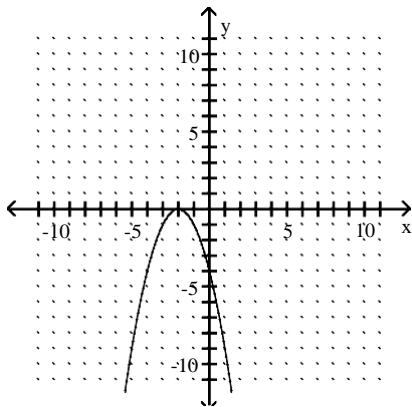

C)

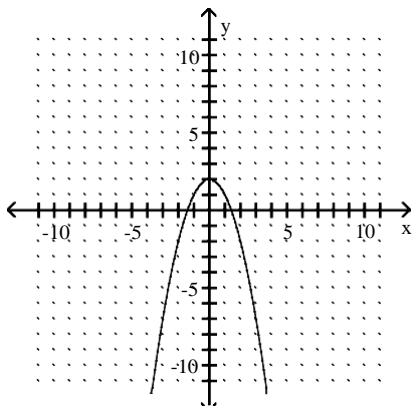

D)

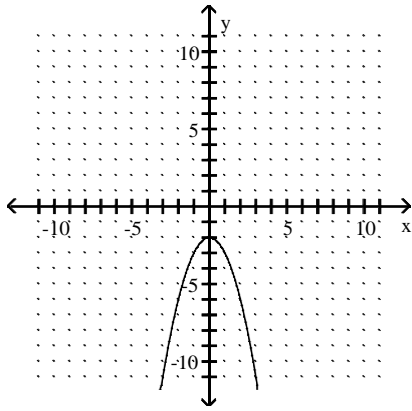

Answer: C

45) $y = x^3 - 2$

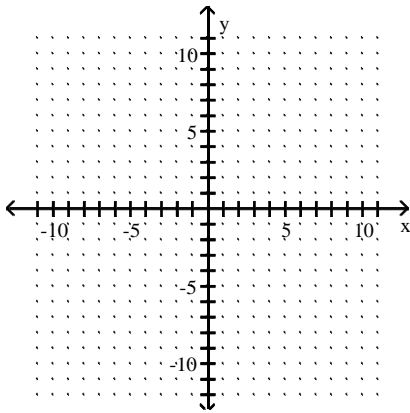

A)

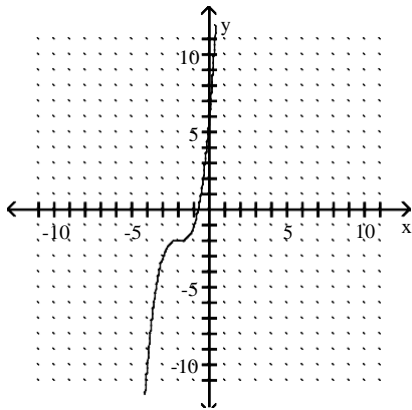

B)

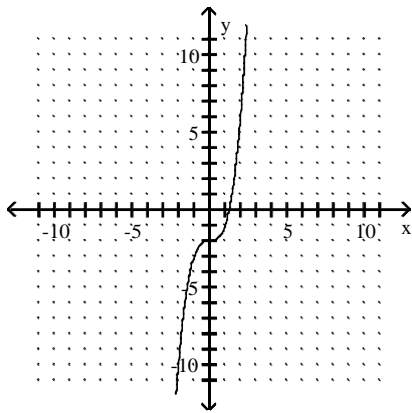

C)

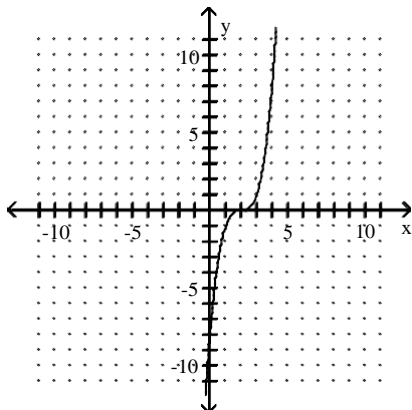

D)

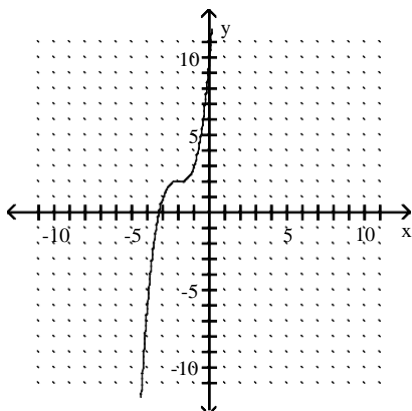

Answer: B

46) $y = (x + 4)^3$

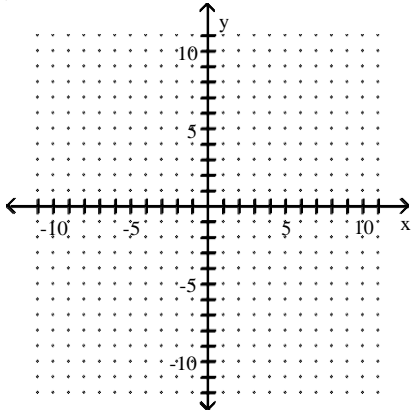

A)

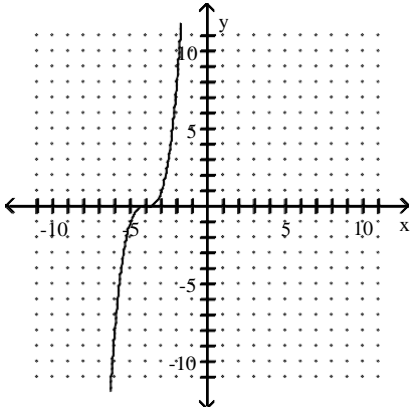

B)

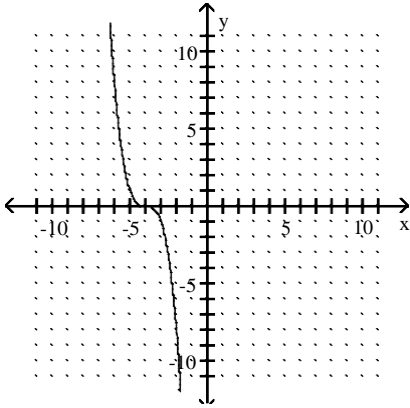

C)

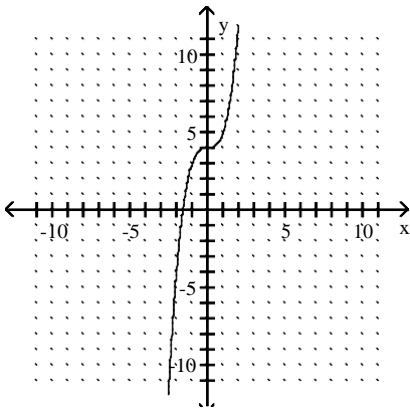

D)

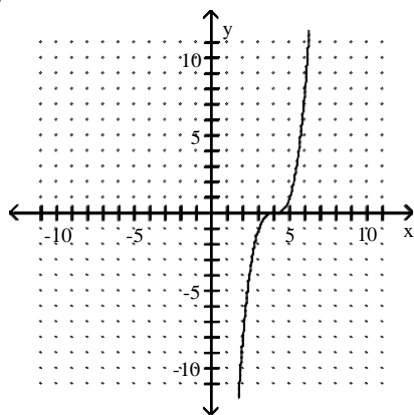

Answer: A

Provide an appropriate response.

47) If the point (a, b) is in the fourth quadrant, in what quadrant is $(a, -b)$?

- A) IV
- B) III
- C) II
- D) I

Answer: D

48) If the point (a, b) is in the fourth quadrant, in what quadrant is $(-a, -b)$?

- A) I
- B) IV
- C) III
- D) II

Answer: D

49) If the point (a, b) is in the fourth quadrant, in what quadrant is (b, a) ?

- A) III
- B) II
- C) IV
- D) I

Answer: B

50) If a vertical line is drawn through the point $(-5, -4)$, where will it intersect the x-axis?

- A) $(-4, 0)$
- B) $(-5, 0)$
- C) $(0, -4)$
- D) $(0, -5)$

Answer: B

51) If a horizontal line is drawn through the point $(5, 6)$, where will it intersect the y-axis?

- A) $(0, 6)$
- B) $(6, 0)$
- C) $(0, 5)$
- D) $(5, 0)$

Answer: A

52) What is the midpoint of the segment joining (d, x) and $(-5d, 7x)$?

- A) $(-3d, 4x)$
- B) $(-2d, 4x)$
- C) $(-4d, 8x)$
- D) $(2d, 3x)$

Answer: B

53) What is the distance from the origin to the point $(m, -n)$?

- A) $\sqrt{m^2 + n^2}$
- B) $m^2 + n^2$
- C) $\sqrt{m^2 - n^2}$
- D) $\sqrt{m - n}$

Answer: A

54) What is the distance from the point (c, z) to the point (m, q) ?

- A) $\sqrt{(c - z)^2 + (m - q)^2}$
- B) $[\sqrt{m - c} + \sqrt{q - z}]^2$
- C) $\sqrt{(m - c)^2 - (q - z)^2}$
- D) $\sqrt{(m - c)^2 + (q - z)^2}$

Answer: D

55) Are the points $A(-3, 4)$, $B(0, 7)$, $C(2, -1)$, and $D(5, 2)$ the vertices of a parallelogram (opposite sides equal in length)? of a rhombus (all sides equal in length)?

- A) no; no
- B) yes; yes
- C) yes; no
- D) no; yes

Answer: C

56) Are the points $A(-3, 11)$, $B(0, 8)$, $C(2, 0)$, and $D(5, 3)$ the vertices of a parallelogram (opposite sides equal in length)? of a rhombus (all sides equal in length)?

- A) yes; yes
- B) no; yes
- C) no; no
- D) yes; no

Answer: C

Find the center-radius form of the equation of the circle.

57) center $(0, 0)$, radius 5

- A) $x^2 + y^2 = \sqrt{5}$
- B) $x^2 + y^2 = 10$
- C) $x^2 + y^2 = 25$
- D) $x^2 + y^2 = 5$

Answer: C

58) center (9, 6), radius 11

A) $(x + 9)^2 + (y + 6)^2 = 121$

B) $(x + 6)^2 + (y + 9)^2 = 11$

C) $(x - 9)^2 + (y - 6)^2 = 121$

D) $(x - 6)^2 + (y - 9)^2 = 11$

Answer: C

59) center (7, 0), radius 8

A) $x^2 + (y - 7)^2 = 8$

B) $(x - 7)^2 + y^2 = 64$

C) $x^2 + (y + 7)^2 = 8$

D) $(x + 7)^2 + y^2 = 64$

Answer: B

60) center (0, 10), radius 8

A) $(x + 10)^2 + y^2 = 64$

B) $(x - 10)^2 + y^2 = 64$

C) $x^2 + (y + 10)^2 = 8$

D) $x^2 + (y - 10)^2 = 64$

Answer: D

61) center (-9, -8), radius $\sqrt{14}$

A) $(x + 8)^2 + (y + 9)^2 = 196$

B) $(x - 8)^2 + (y - 9)^2 = 196$

C) $(x - 9)^2 + (y - 8)^2 = 14$

D) $(x + 9)^2 + (y + 8)^2 = 14$

Answer: D

62) center (0, -1), radius $\sqrt{3}$

A) $(x - 1)^2 + y^2 = 9$

B) $x^2 + (y - 1)^2 = 3$

C) $(x + 1)^2 + y^2 = 9$

D) $x^2 + (y + 1)^2 = 3$

Answer: D

63) center (-10, 0), radius $\sqrt{13}$

A) $(x + 10)^2 + y^2 = \sqrt{13}$

B) $x^2 + (y + 10)^2 = 169$

C) $(x - 10)^2 + y^2 = 13$

D) $(x + 10)^2 + y^2 = 13$

Answer: D

64) center $(-\sqrt{15}, -5)$, radius $\sqrt{15}$

A) $(x - \sqrt{15})^2 + (y - 5)^2 = 15$

B) $(x + \sqrt{15})^2 + (y + 5)^2 = \sqrt{15}$

C) $(x + \sqrt{15})^2 + (y + 5)^2 = 15$

D) $(x - \sqrt{15})^2 + (y - 5)^2 = 225$

Answer: C

Graph the circle.

65) $x^2 + y^2 = 64$

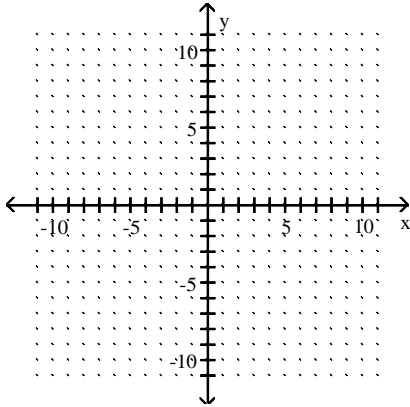

A)

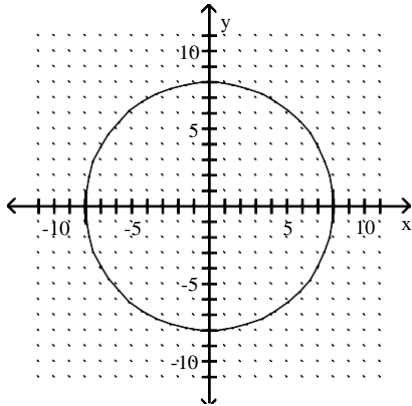

B)

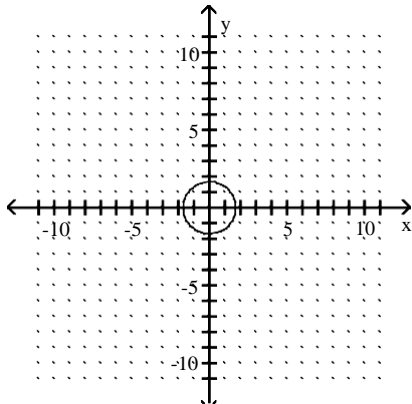

C)

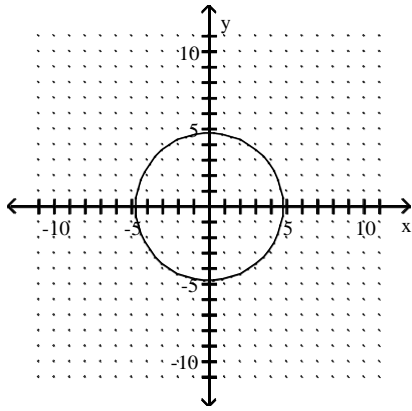

D)

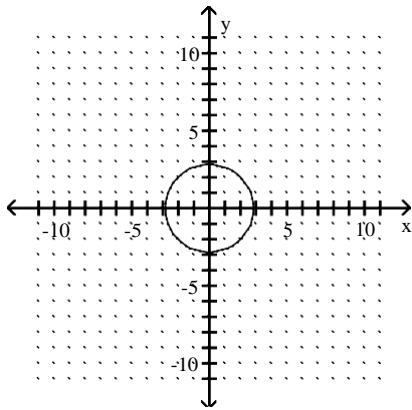

Answer: A

66) $(x - 2)^2 + (y + 1)^2 = 16$

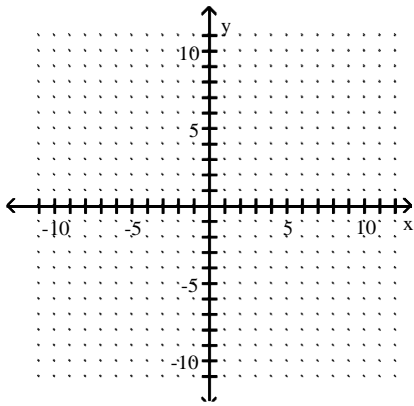

A)

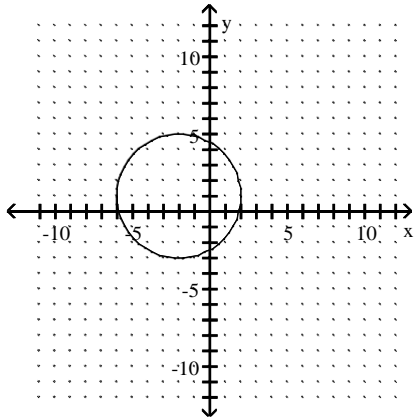

B)

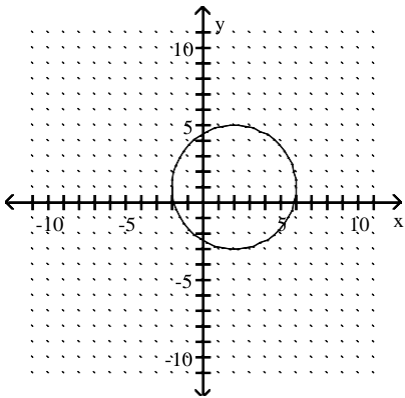

C)

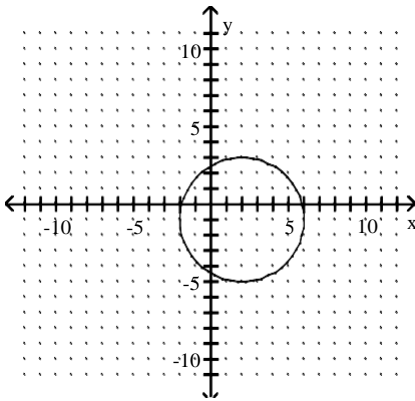

D)

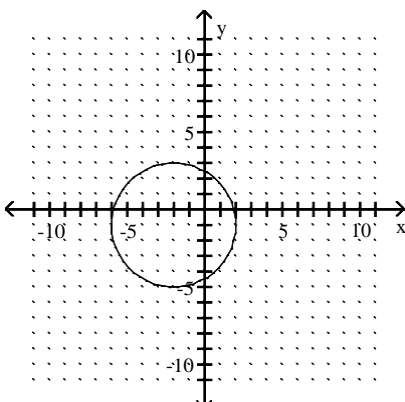

Answer: C

67) $(x - 1)^2 + (y - 5)^2 = 4$

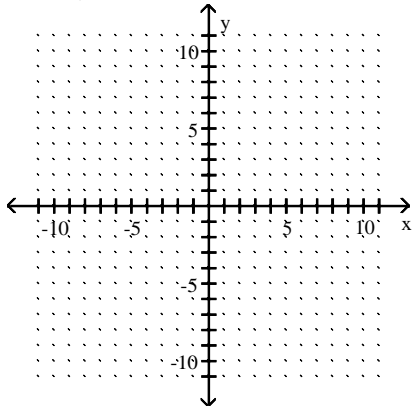

A)

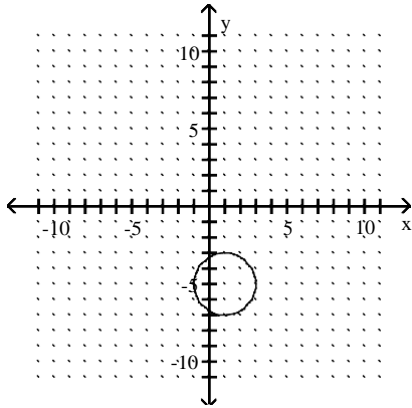

B)

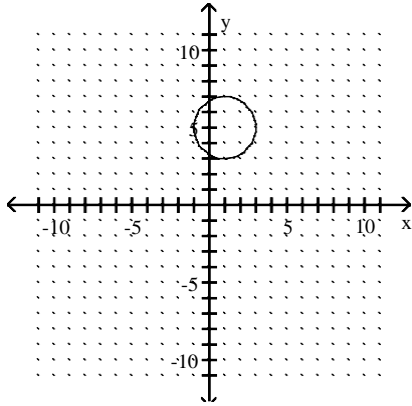

C)

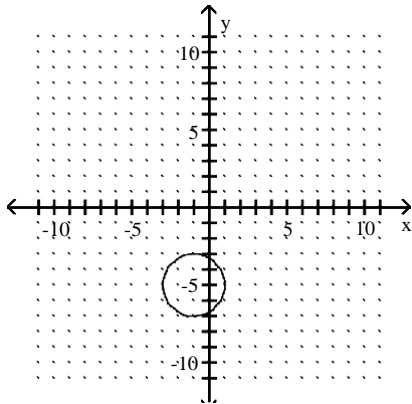

D)

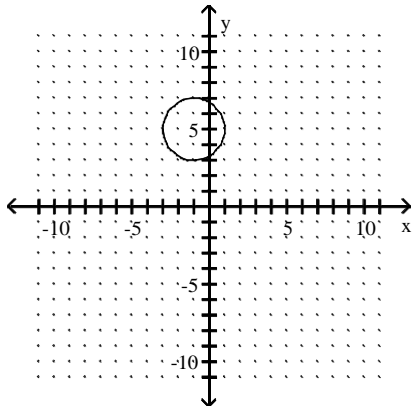

Answer: B

$$68) x^2 + (y - 2)^2 = 36$$

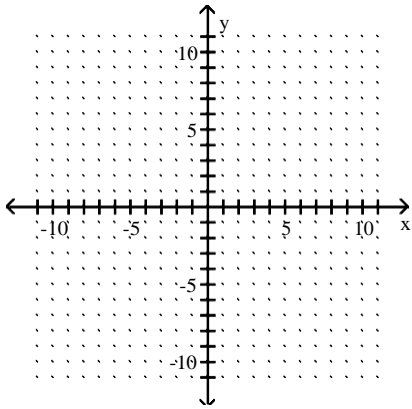

A)

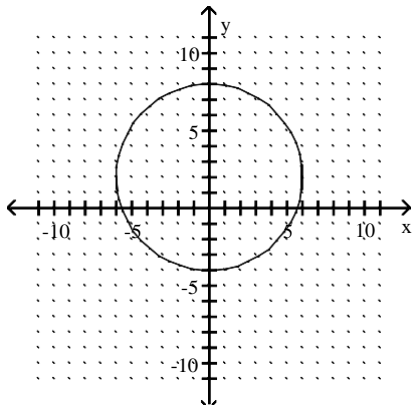

B)

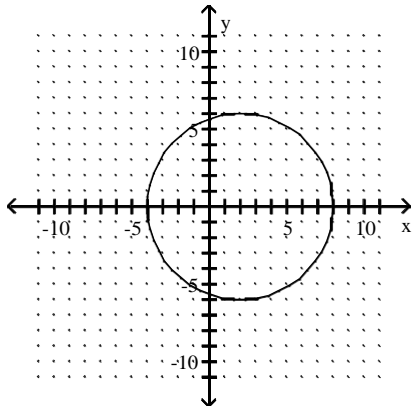

C)

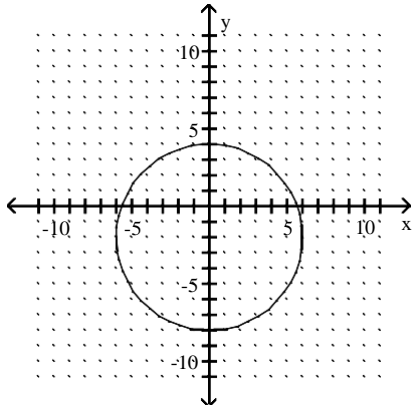

D)

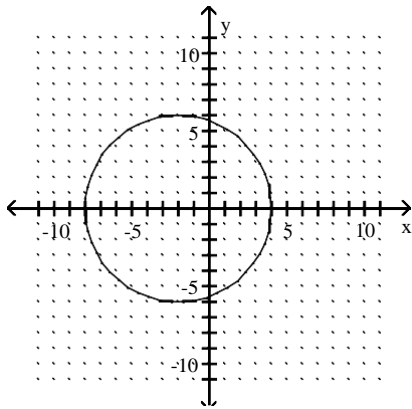

Answer: A

69) $(x - 5)^2 + y^2 = 4$

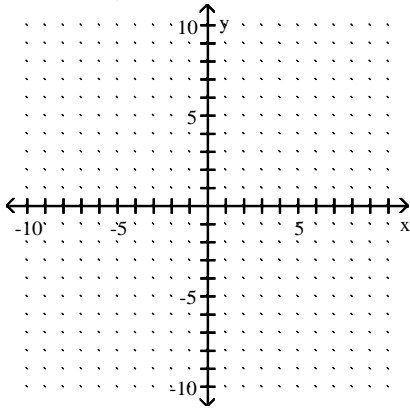

A)

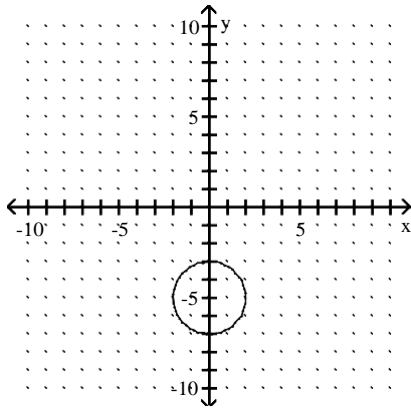

B)

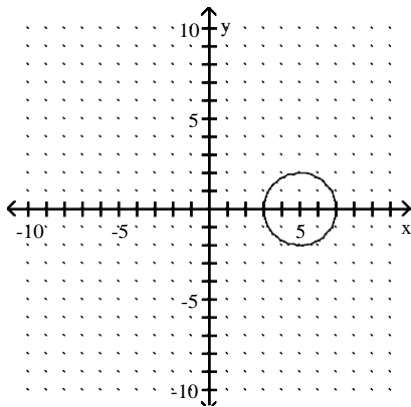

C)

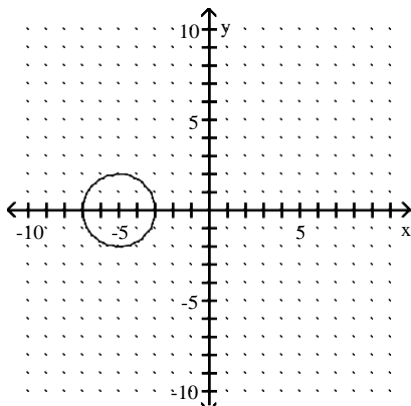

D)

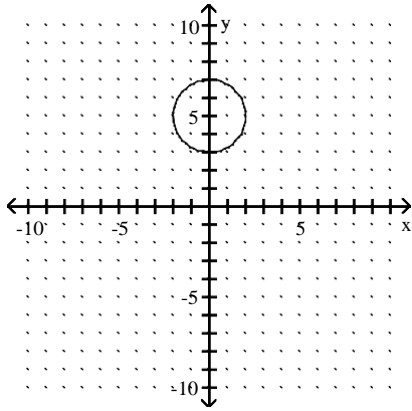

Answer: B

Use the graph to determine the equation of the circle in center-radius form.

70)

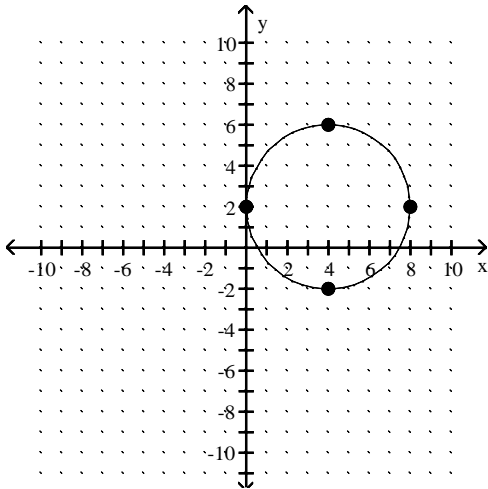

- A) $(x + 4)^2 + (y + 2)^2 = 4$
- B) $(x - 4)^2 + (y - 2)^2 = 16$
- C) $(x + 4)^2 + (y + 2)^2 = 16$
- D) $(x - 4)^2 + (y - 2)^2 = 4$

Answer: B

71)

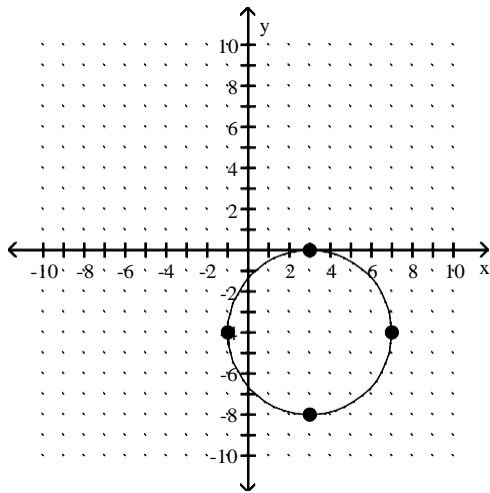

- A) $(x - 3)^2 + (y + 4)^2 = 4$
- B) $(x + 3)^2 + (y - 4)^2 = 4$
- C) $(x + 3)^2 + (y - 4)^2 = 16$
- D) $(x - 3)^2 + (y + 4)^2 = 16$

Answer: D

72)

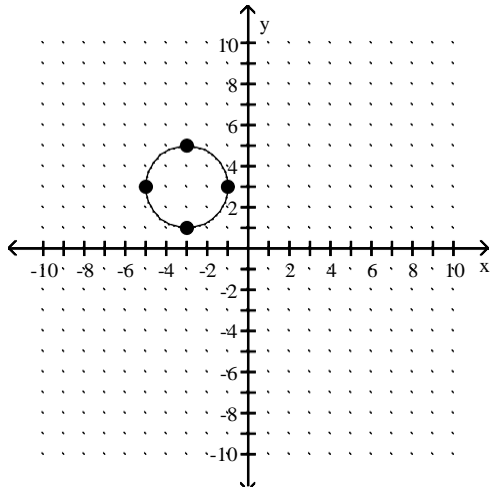

- A) $(x + 3)^2 + (y - 3)^2 = 4$
- B) $(x - 3)^2 + (y + 3)^2 = 2$
- C) $(x - 3)^2 + (y + 3)^2 = 4$
- D) $(x + 3)^2 + (y - 3)^2 = 2$

Answer: A

73)

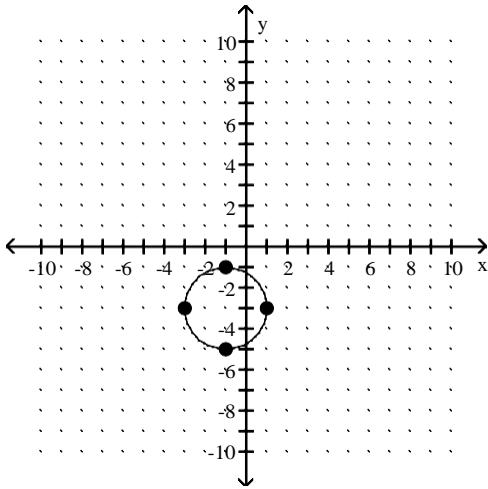

- A) $(x + 1)^2 + (y + 3)^2 = 2$
- B) $(x + 1)^2 + (y + 3)^2 = 4$
- C) $(x - 1)^2 + (y - 3)^2 = 2$
- D) $(x - 1)^2 + (y - 3)^2 = 4$

Answer: B

Decide whether or not the equation has a circle as its graph. If it does not, describe the graph.

74) $x^2 + y^2 - 16x - 4y + 64 = 0$

- A) no; the graph is the point $(-8, -2)$
- B) no; the graph is nonexistent
- C) yes
- D) no; the graph is the point $(8, 2)$

Answer: C

75) $x^2 + y^2 - 12x + 4y + 31 = 0$

- A) yes
- B) no; the graph is the point $(-6, 2)$
- C) no; the graph is nonexistent
- D) no; the graph is the point $(6, -2)$

Answer: A

76) $x^2 + y^2 + 8x - 10y + 41 = 0$

- A) no; the graph is nonexistent
- B) no; the graph is the point $(-4, 5)$
- C) yes
- D) no; the graph is the point $(4, -5)$

Answer: B

77) $x^2 + y^2 + 18x - 2y + 211 = 0$

- A) no; the graph is nonexistent
- B) no; the graph is the point $(9, -1)$
- C) yes
- D) no; the graph is the point $(-9, 1)$

Answer: A

78) $2x^2 + 2y^2 - 4x + 12y - 12 = 0$

- A) no; the graph is the point (-1, 3)
- B) yes
- C) no; the graph is nonexistent
- D) no; the graph is the point (1, -3)

Answer: B

Find the center and radius of the circle.

79) $x^2 + y^2 - 4x - 18y + 49 = 0$

- A) center: (-9, -2); radius: 36
- B) center: (-2, -9); radius: 36
- C) center: (9, 2); radius: 6
- D) center: (2, 9); radius: 6

Answer: D

80) $x^2 + y^2 - 8x - 10y + 16 = 0$

- A) center: (-5, -4); radius: 25
- B) center: (5, 4); radius: 5
- C) center: (4, 5); radius: 5
- D) center: (-4, -5); radius: 25

Answer: C

81) $x^2 + y^2 + 8x - 16y + 71 = 0$

- A) center: (8, -4); radius: 3
- B) center: (-4, 8); radius: 3
- C) center: (4, -8); radius: 9
- D) center: (-8, 4); radius: 9

Answer: B

82) $5x^2 + 5y^2 + 40x - 40y + 80 = 0$

- A) center: (4, -4), radius: 4
- B) center: (-4, 4), radius: 4
- C) center: (4, -4), radius: 16
- D) center: (-4, 4), radius: 16

Answer: B

Find the center-radius form of the circle described or graphed.

83) a circle having a diameter with endpoints (-1, -4) and (-1, 4)

- A) $(x + 4)^2 + y^2 = 1$
- B) $(x + 1)^2 + y^2 = 16$
- C) $x^2 + (y + 4)^2 = 1$
- D) $(x + 1)^2 + y^2 = 4$

Answer: B

84) a circle having a diameter with endpoints (0, 4) and (10, 0)

A) $(x - 2)^2 + (y - 5)^2 = 29$

B) $(x - 5)^2 + (y - 2)^2 = 29$

C) $x^2 + (y - 2)^2 = 25$

D) $(x - 5)^2 + y^2 = 4$

Answer: B

85) a circle having a diameter with endpoints (-6, -4) and (-8, 2)

A) $(x - 1)^2 + (y + 3)^2 = 40$

B) $(x - 7)^2 + (y + 1)^2 = 232$

C) $(x - 7)^2 + (y - 1)^2 = 200$

D) $(x + 7)^2 + (y + 1)^2 = 10$

Answer: D

86)

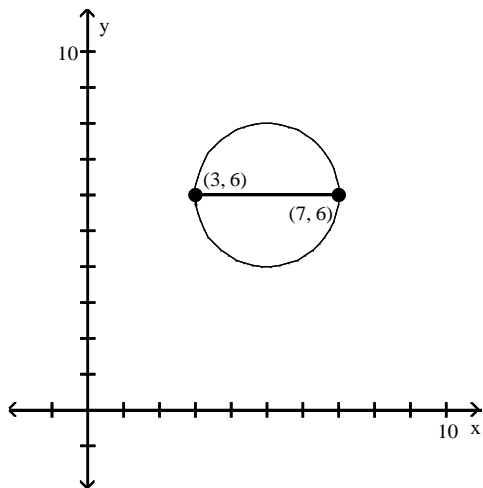

A) $(x + 5)^2 + (y + 6)^2 = 4$

B) $(x - 5)^2 + (y - 6)^2 = 4$

C) $(x - 5)^2 + (y - 6)^2 = 2$

D) $(x + 5)^2 + (y + 6)^2 = 2$

Answer: B

87)

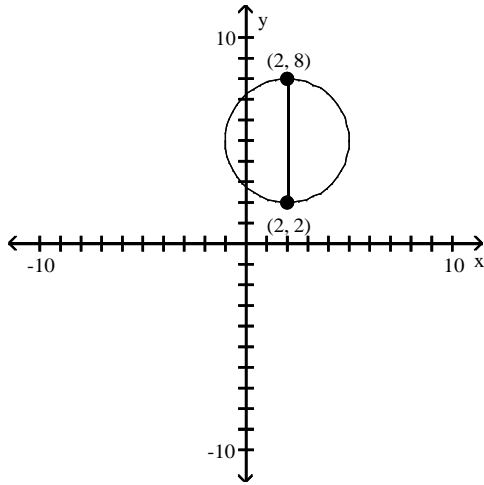

- A) $(x - 2)^2 + (y - 5)^2 = 9$
- B) $(x + 2)^2 + (y + 5)^2 = 3$
- C) $(x + 2)^2 + (y + 5)^2 = 9$
- D) $(x - 2)^2 + (y - 5)^2 = 3$

Answer: A

Solve the problem.

88) Suppose that receiving stations X, Y, and Z are located on a coordinate plane at the points (0, 9), (-12, 17), and (-8, -7) respectively. The epicenter of an earthquake is determined to be 5 units from X, 15 units from Y, and 13 units from Z. Where on the coordinate plane is the epicenter located?

- A) at (-2, 4)
- B) at (-4, 7)
- C) at (-2, 5)
- D) at (-3, 5)

Answer: D

89) The locations of three receiving stations and the distances to the epicenter of an earthquake are contained in the following three equations: $(x + 3)^2 + (y + 2)^2 = 9$, $(x + 8)^2 + (y + 5)^2 = 25$, $(x - 3)^2 + (y + 13)^2 = 100$. Determine the location of the epicenter.

- A) at (-3, -5)
- B) at (-2, -6)
- C) at (-4, -3)
- D) at (-2, -5)

Answer: A

90) Find the center-radius form of the equation of a circle with center (3, 8) and tangent to the x-axis.

- A) $(x - 3)^2 + (y - 8)^2 = 9$
- B) $(x - 3)^2 + (y - 8)^2 = 64$
- C) $(x + 3)^2 + (y + 8)^2 = 9$
- D) $(x + 3)^2 + (y + 8)^2 = 64$

Answer: B

91) Find the equation of a circle with center at $(-5, 3)$, passing through the point $(1, 11)$. Write it in center-radius form.

A) $(x + 5)^2 + (y - 3)^2 = 10$

B) $(x - 5)^2 + (y + 3)^2 = 10$

C) $(x - 5)^2 + (y + 3)^2 = 100$

D) $(x + 5)^2 + (y - 3)^2 = 100$

Answer: D

92) Find all points (x, y) with $x = y$ that are 5 units from $(-1, 6)$.

A) $(-2, -2)$ and $(3, 3)$

B) $(2, 2)$ and $(3, 3)$

C) $(-2, -2)$ and $(-3, -3)$

D) $(2, 2)$ and $(-3, -3)$

Answer: B

93) Find all values of y such that the distance between $(2, y)$ and $(-10, 3)$ is 13.

A) $-8, 2$

B) $-2, 8$

C) $-8, -2$

D) $2, 8$

Answer: B

94) A circle has a diameter with endpoints $(-2, 1)$ and $(10, 13)$. Find the coordinates of the center.

A) $(22, 25)$

B) $(-8, -5)$

C) $(8, 14)$

D) $(4, 7)$

Answer: D

95) A circle has a diameter with endpoints $(-2, 1)$ and $(4, 9)$. Find the radius.

A) 5

B) $\sqrt{10}$

C) 10

D) $\sqrt{5}$

Answer: A

96) Find the center-radius form of the equation of the circle having a diameter with endpoints $(-5, 1)$ and $(3, 7)$.

A) $(x - 1)^2 + (y + 4)^2 = 5$

B) $(x + 3)^2 + (y - 7)^2 = 10$

C) $(x - 3)^2 + (y + 7)^2 = 100$

D) $(x + 1)^2 + (y - 4)^2 = 25$

Answer: D

Decide whether the relation defines a function.

97) $\{(-3, -2), (3, 6), (4, 6), (7, -7), (10, -1)\}$

A) Not a function

B) Function

Answer: B

98) $\{(-5, 1), (-3, -6), (3, -3), (3, 5)\}$

- A) Function
- B) Not a function

Answer: B

99) $\{(-8, 2), (-8, 8), (1, 4), (6, -4), (10, 2)\}$

- A) Function
- B) Not a function

Answer: B

100) $\{(-3, -4), (-1, 4), (4, -7), (7, 4)\}$

- A) Function
- B) Not a function

Answer: A

101)

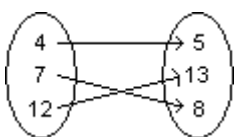

- A) Function
- B) Not a function

Answer: A

102)

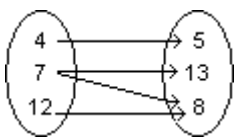

- A) Not a function
- B) Function

Answer: A

103)

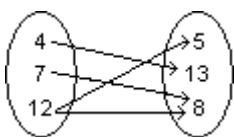

- A) Function
- B) Not a function

Answer: B

104) Student Test Score

Name	Test Score
Bob L.	76
Susan H.	83
Jim H.	76
Bruce B.	96

- A) Function
- B) Not a function

Answer: A

105) Student Test Score

Name	Test Score
Bob L.	91
Susan H.	83
Jim H.	91
Bruce B.	96

- A) Function
- B) Not a function

Answer: A

106) Annual New Telemarketing Companies

Year	Number
1995	28
1996	56
1997	131
1998	94
1999	234

- A) Function
- B) Not a function

Answer: A

107)

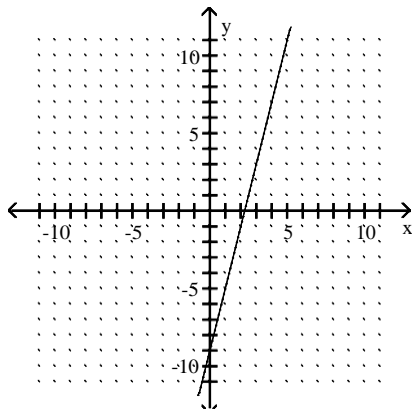

- A) Function
- B) Not a function

Answer: A

108)

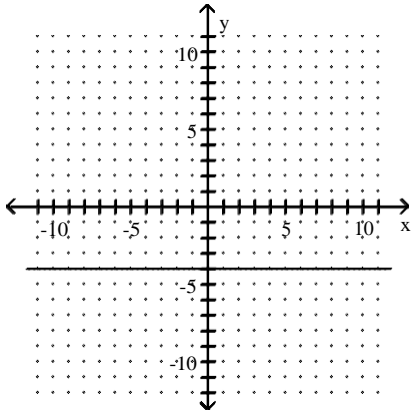

- A) Function
- B) Not a function

Answer: A

109)

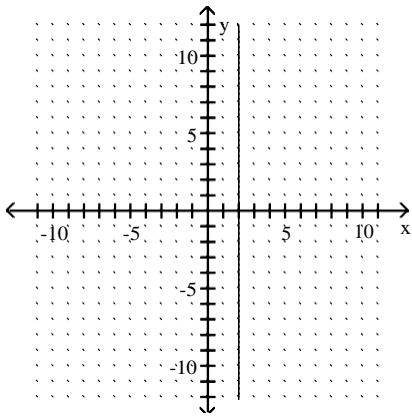

- A) Not a function
- B) Function

Answer: A

110)

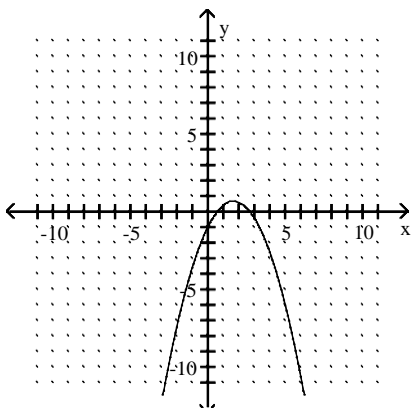

- A) Function
- B) Not a function

Answer: A

111)

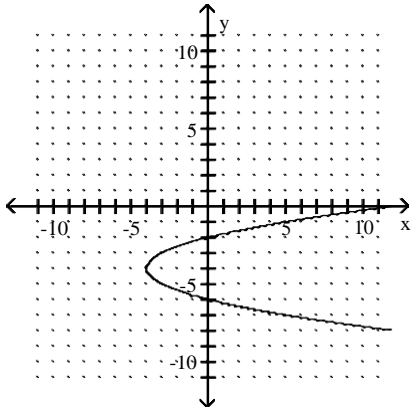

- A) Function
- B) Not a function

Answer: B

112)

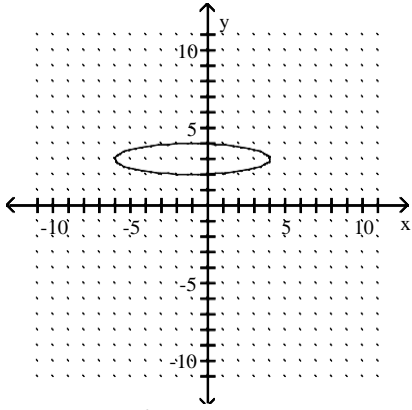

- A) Not a function
- B) Function

Answer: A

113)

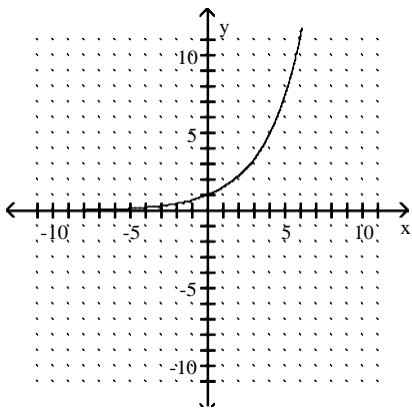

- A) Function
- B) Not a function

Answer: A

114)

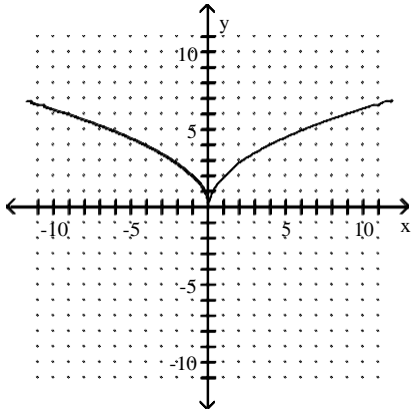

- A) Function
- B) Not a function

Answer: A

115)

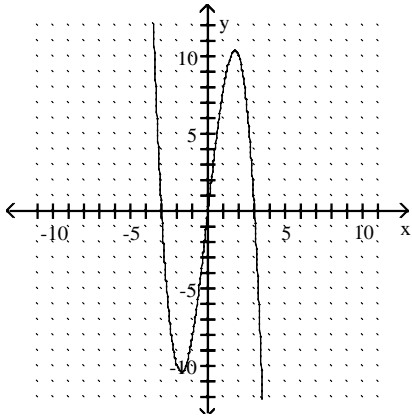

- A) Not a function
- B) Function

Answer: B

116)

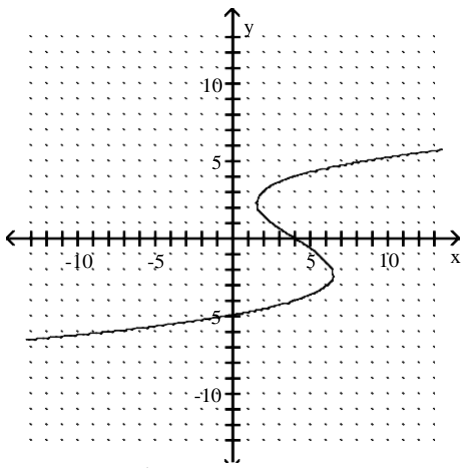

- A) Not a function
- B) Function

Answer: A

Give the domain and range of the relation.

117) $\{(2, 9), (-3, -8), (-6, -5), (5, 0)\}$

- A) domain: $\{2, 5, 9\}$; range: $\{-8, -6, -5, -3\}$
- B) domain: $\{-8, -5, 0, 9\}$; range: $\{-6, -3, 2, 5\}$
- C) domain: $\{-6, -3, 2, 5\}$; range: $\{-8, -5, 0, 9\}$
- D) domain: $\{-8, -6, -5, -3\}$; range: $\{2, 5, 9\}$

Answer: C

118) $\{(1, 9), (-1, -9), (-7, -5), (6, -9)\}$

- A) domain: $\{-9, -5, 9\}$; range: $\{-7, -1, 1, 6\}$
- B) domain: $\{-7, -1, 1, 6\}$; range: $\{-9, -5, 9\}$
- C) domain: $\{-9, -7, -5, -1\}$; range: $\{1, 6, 9\}$
- D) domain: $\{1, 6, 9\}$; range: $\{-9, -7, -5, -1\}$

Answer: B

119) $\{(1, 1), (-3, -3), (-7, -7), (4, 4)\}$

- A) domain: $\{-7, -3\}$; range: $\{1, 4\}$
- B) None of these
- C) domain: $\{1, 4\}$; range: $\{-7, -3\}$
- D) domain: $\{-7, -3, 1, 4\}$; range: $\{-7, -3, 1, 4\}$

Answer: D

120)

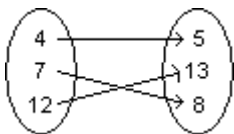

- A) None of these
- B) domain: $\{4, 5, 7\}$; range: $\{8, 12, 13\}$
- C) domain: $\{5, 8, 13\}$; range: $\{4, 7, 12\}$
- D) domain: $\{4, 7, 12\}$; range: $\{5, 8, 13\}$

Answer: D

121)

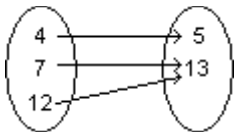

- A) domain: $\{4, 5, 7\}$; range: $\{12, 13\}$
- B) domain: $\{5, 13\}$; range: $\{4, 7, 12\}$
- C) domain: $\{4, 7, 12\}$; range: $\{5, 13\}$
- D) None of these

Answer: C

122)

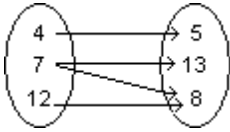

- A) domain: {4, 7, 12}; range: {5, 8, 13}
- B) domain: {5, 8, 13}; range: {4, 7, 12}
- C) None of these
- D) domain: {4, 12}; range: {5, 13}

Answer: A

123)

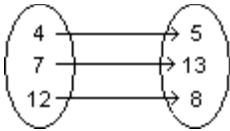

- A) domain: {4, 8, 12}; range: {5, 7, 13}
- B) domain: {4, 7, 12}; range: {5, 8, 13}
- C) domain: {5, 8, 13}; range: {4, 7, 12}
- D) None of these

Answer: B

124)

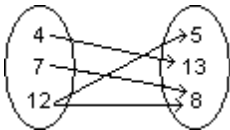

- A) domain: {4, 8, 12}; range: {5, 7, 13}
- B) None of these
- C) domain: {4, 7, 12}; range: {5, 8, 13}
- D) domain: {5, 8, 13}; range: {4, 7, 12}

Answer: D

125) Annual New Telemarketing Companies

Year	Number
1995	56
1996	112
1997	187
1998	178
1999	318

- A) None of these
- B) domain: {1995, 1996, 1997, 1998, 1999}; range: {56, 112, 178, 187, 318}
- C) domain: {Year}; range: {Number}
- D) domain: {56, 112, 178, 187, 318}; range: {1995, 1996, 1997, 1998, 1999}

Answer: B

126) Annual New Telemarketing Companies

Year	Number
1993	52
1994	102
1995	187
1996	170
1997	218

- A) None of these
- B) domain: {Year}; range: {Number}
- C) domain: {52, 102, 170, 187, 218}; range: {1993, 1994, 1995, 1996, 1997}
- D) domain: {1993, 1994, 1995, 1996, 1997}; range: {52, 102, 170, 187, 218}

Answer: D

127)

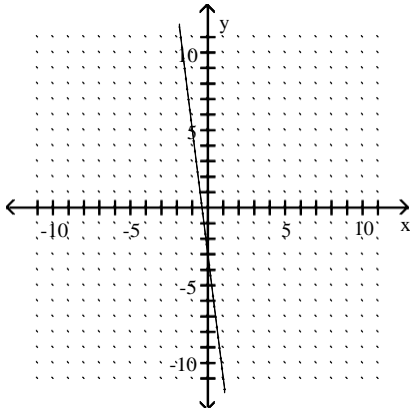

- A) domain: $(-\infty, -3) \cup (-3, \infty)$; range: $(-\infty, 0) \cup (0, \infty)$
- B) domain: $(-\infty, 0) \cup (0, \infty)$; range: $(-\infty, -3) \cup (-3, \infty)$
- C) domain: $(-\infty, \infty)$; range: $(-\infty, \infty)$
- D) domain: $(-\infty, 0] \cup [0, \infty)$; range: $(-\infty, -3] \cup [-3, \infty)$

Answer: C

128)

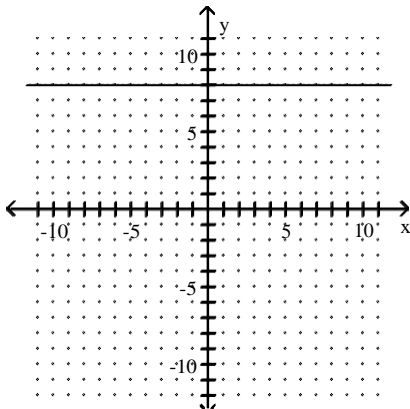

- A) domain: $(-\infty, \infty)$; range: {8}
- B) domain: $(-\infty, \infty)$; range: $(-\infty, \infty)$
- C) domain: $(-\infty, \infty)$; range: $(-\infty, 8) \cup (8, \infty)$
- D) domain: {8}; range: $(-\infty, \infty)$

Answer: A

129)

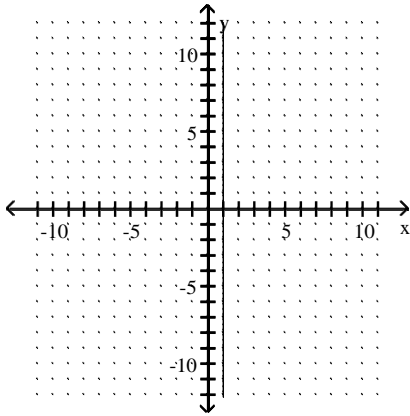

- A) domain: $(-\infty, \infty)$; range: $(-\infty, \infty)$
- B) domain: $\{1\}$; range: $(-\infty, \infty)$
- C) domain: $(-\infty, 1) \cup (1, \infty)$; range: $(-\infty, \infty)$
- D) domain: $(-\infty, \infty)$; range: $\{1\}$

Answer: B

130)

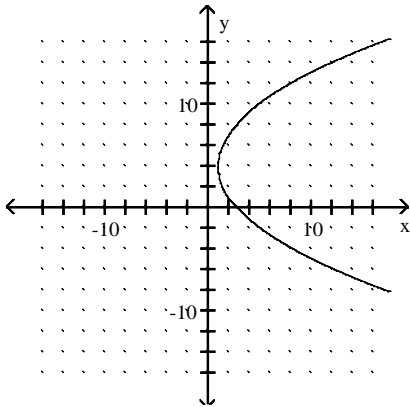

- A) domain: $(1, \infty)$; range: $(4, \infty)$
- B) domain: $(-\infty, \infty)$; range: $(-\infty, \infty)$
- C) domain: $[1, \infty)$; range: $(-\infty, \infty)$
- D) domain: $(-\infty, \infty)$; range: $[1, \infty)$

Answer: C

131)

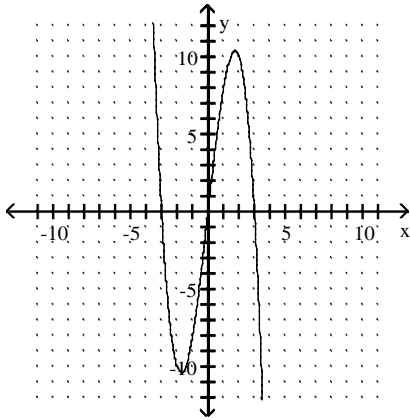

A) range: $(-3, 0) \cup (0, 3)$; domain: $(-10, 0) \cup (0, 10)$

B) range: $(-\infty, \infty)$; domain: $(-\infty, \infty)$

C) range: $(-3, 3)$; domain: $(-10, 10)$

D) range: $(-\infty, -3) \cup (-3, 0) \cup (0, 3) \cup (3, \infty)$; domain: $(-\infty, -10) \cup (-10, 0) \cup (0, 10) \cup (10, \infty)$

Answer: B

132)

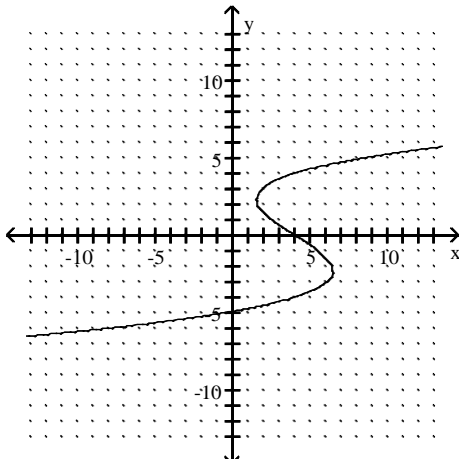

A) range: $(-\infty, 4) \cup (4, \infty)$; domain: $(-\infty, -5) \cup (-5, \infty)$

B) range: $(-\infty, 0) \cup (0, 4) \cup (4, \infty)$; domain: $(-\infty, -5) \cup (-5, 0) \cup (0, \infty)$

C) range: $(-\infty, \infty)$; domain: $(-\infty, \infty)$

D) None of these

Answer: C

133)

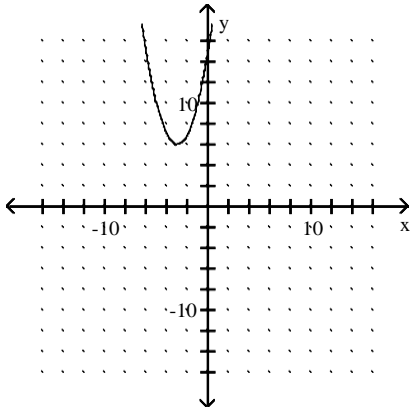

- A) domain: $(0, \infty)$; range: $[3, \infty)$
- B) domain: $(-\infty, 0) \cup (0, \infty)$; range: $(-\infty, 0) \cup (0, \infty)$
- C) domain: $(-\infty, \infty)$; range: $[6, \infty)$
- D) domain: $(-\infty, 0)$; range: $(-\infty, 0)$

Answer: C

134)

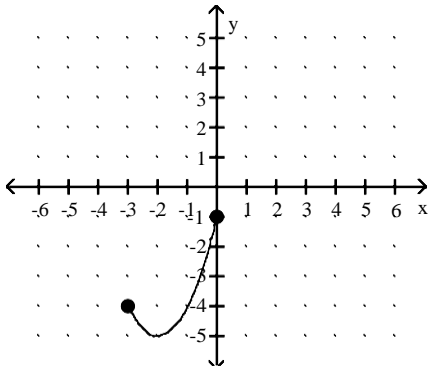

- A) domain: $[-3, 0]$; range: $[-5, -1]$
- B) domain: $[-5, -1]$; range: $[-3, 0]$
- C) domain: $(-\infty, -1]$; range: $[0, 3]$
- D) domain: $[0, 3]$; range: $(-\infty, -1]$

Answer: A

135)

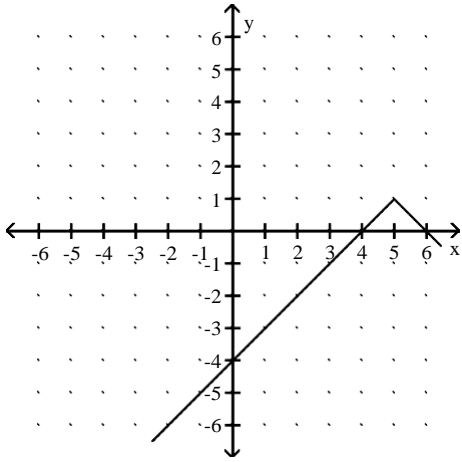

- A) domain: $(-\infty, 5)$ or $(5, \infty)$; range: $(-\infty, 1)$ or $(1, \infty)$
- B) domain: $(-\infty, 5]$; range: $(-\infty, 1]$
- C) domain: $(-\infty, \infty)$; range: $(-\infty, \infty)$
- D) domain: $(-\infty, \infty)$; range: $(-\infty, 1]$

Answer: D

136)

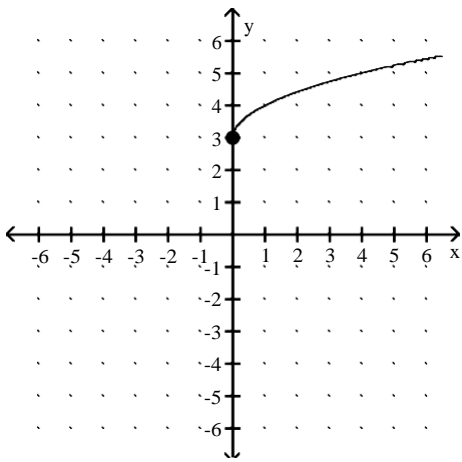

- A) domain: $[0, \infty)$; range: $[3, \infty)$
- B) domain: $(-\infty, \infty)$; range: $[3, \infty)$
- C) domain: $[0, \infty)$; range: $[0, \infty)$
- D) domain: $[0, \infty)$; range: $(-\infty, \infty)$

Answer: A

Decide whether the relation defines a function.

137) $3x = 9 - 4y$

- A) Function
- B) Not a function

Answer: A

138) $y = 5x - 2$

- A) Not a function
- B) Function

Answer: B

139) $y = x^3$

- A) Function
- B) Not a function

Answer: A

140) $y^2 = 5x$

- A) Not a function
- B) Function

Answer: A

141) $y = \sqrt{5x - 6}$

- A) Function
- B) Not a function

Answer: A

142) $10x - 2y > -9$

- A) Function
- B) Not a function

Answer: B

143) $x = y^6$

- A) Function
- B) Not a function

Answer: B

144) $y = x^2$

- A) Not a function
- B) Function

Answer: B

145) $xy = -3$

- A) Function
- B) Not a function

Answer: A

146) $y = \frac{5}{x - 1}$

- A) Function
- B) Not a function

Answer: A

Give the domain and range of the relation.

147) $y = x^2 + 8$

- A) domain: $(-\infty, \infty)$; range: $[8, \infty)$
- B) domain: $(8, \infty)$; range: $(-\infty, \infty)$
- C) domain: $(-\infty, \infty)$; range: $(-8, \infty)$
- D) domain: $(-8, \infty)$; range: $(-\infty, \infty)$

Answer: A

148) $y = (x + 4)^2 - 4$

- A) domain: $(-\infty, -4)$; range: $(-\infty, \infty)$
- B) domain: $(4, \infty)$; range: $(-\infty, \infty)$
- C) domain: $(-\infty, \infty)$; range: $[-4, \infty)$
- D) domain: $(-\infty, \infty)$; range: $(-\infty, -4)$

Answer: C

149) $y = 2x + 11$

- A) domain: $(-\infty, \infty)$; range: $[0, \infty)$
- B) domain: $[0, \infty)$; range: $(-\infty, \infty)$
- C) domain: $(-\infty, \infty)$; range: $(-\infty, \infty)$
- D) domain: $(-\infty, \infty)$; range: $[11, \infty)$

Answer: C

150) $y = 3x^7$

- A) domain: $(-\infty, \infty)$; range: $[3, \infty)$
- B) domain: $(-\infty, \infty)$; range: $(-\infty, \infty)$
- C) domain: $(-\infty, \infty)$; range: $[0, \infty)$
- D) domain: $(-\infty, \infty)$; range: $[-3, \infty)$

Answer: B

151) $x = y^4$

- A) domain: $[0, \infty)$; range: $[0, \infty)$
- B) domain: $(-\infty, \infty)$; range: $(-\infty, \infty)$
- C) domain: $[0, \infty)$; range: $(-\infty, \infty)$
- D) domain: $(-\infty, \infty)$; range: $[0, \infty)$

Answer: C

152) $xy = 8$

- A) domain: $(-\infty, 0) \cup (0, \infty)$; range: $[0, \infty)$
- B) domain: $(-\infty, 0) \cup (0, \infty)$; range: $(-\infty, 0) \cup (0, \infty)$
- C) domain: $(-\infty, \infty)$; range: $(-\infty, \infty)$
- D) domain: $[0, \infty)$; range: $(-\infty, \infty)$

Answer: B

153) $y = \sqrt{2 + x}$

- A) domain: $[-2, \infty)$; range: $[0, \infty)$
- B) domain: $(-\infty, \infty)$; range: $(-\infty, \infty)$
- C) domain: $(-\infty, \infty)$; range: $[-2, \infty)$
- D) domain: $[0, \infty)$; range: $(-\infty, \infty)$

Answer: A

$$154) y = \sqrt{4x - 5}$$

A) domain: $\left[\frac{5}{4}, \infty\right)$ range: $[0, \infty)$

B) domain: $\left[\frac{5}{4}, \infty\right)$ range: $(-\infty, \infty)$

C) domain: $(-\infty, \infty)$; range: $\left[\frac{5}{4}, \infty\right)$

D) domain: $\left[\frac{5}{4}, \infty\right)$; range: $[0, \infty)$

Answer: D

$$155) y = \frac{17}{17 - x}$$

A) domain: $(-\infty, 17) \cup (17, \infty)$; range: $(-\infty, \infty)$

B) domain: $(-\infty, \infty)$; range: $(-\infty, \infty)$

C) domain: $(-\infty, \infty)$; range: $(-\infty, 0) \cup (0, \infty)$

D) domain: $(-\infty, 17) \cup (17, \infty)$; range: $(-\infty, 0) \cup (0, \infty)$

Answer: D

$$156) y = \frac{-7}{x - 6}$$

A) domain: $(-\infty, -6) \cup (6, \infty)$; range: $(-\infty, \infty)$

B) domain: $(-\infty, 6) \cup (6, \infty)$; range: $(-\infty, \infty)$

C) domain: $(-\infty, 6) \cup (6, \infty)$; range: $(-\infty, 0) \cup (0, \infty)$

D) domain: $(-\infty, -6) \cup (-6, \infty)$; range: $(-\infty, 0) \cup (0, \infty)$

Answer: C

Evaluate the function.

157) Find $f(-2)$ when $f(x) = -5x + 3$

A) 13

B) 7

C) 4

D) -2

Answer: A

158) Find $f(-1)$ when $f(x) = x^2 - 2x - 7$

A) 10

B) -8

C) -4

D) 6

Answer: C

159) Find $f(0)$ when $f(x) = x^2 + 3x - 5$

A) 0

B) 5

C) -5

D) 25

Answer: C

160) Find $f(-3)$ when $f(x) = 2x^2 + 3x + 5$

- A) 5
- B) 14
- C) 4
- D) 32

Answer: B

161) Find $f\left(\frac{1}{4}\right)$ when $f(x) = 2x^2 + 9x - 7$

- A) $-\frac{37}{8}$
- B) $\frac{37}{8}$
- C) 4
- D) $-\frac{1}{4}$

Answer: A

162) Find $g(a + 1)$ when $g(x) = \frac{1}{5}x + 5$.

- A) $\frac{a + 26}{5}$
- B) $\frac{1}{5}a + 5$
- C) $\frac{1}{5}a - 5$
- D) $\frac{a - 26}{5}$

Answer: A

163) Find $g(a - 1)$ when $g(x) = 2x - 5$.

- A) $2a + 1$
- B) $2a - 5$
- C) $\frac{1}{2}a - 5$
- D) $2a - 7$

Answer: D

164) Find $f(k)$ when $f(x) = 3x^2 + 4x + 5$

- A) $3k^2 + 16k + 5$
- B) $3k^2 + 4k + 25$
- C) $3k^2 + 4k + 5$
- D) $9k^2 + 16k + 25$

Answer: C

165) Find $f(-x)$ when $f(x) = 3x^2 - 5x + 4$

- A) $3x^2 + 5x + 4$
- B) $-3x^2 + 5x + 4$
- C) $-3x^2 + 5x - 4$
- D) $3x^2 + 5x - 4$

Answer: A

166) Find $f(k - 1)$ when $f(x) = 4x^2 - 3x + 4$

- A) $4k^2 + 13k + 5$
- B) $4k^2 - 11k + 11$
- C) $4k^2 - 11k + 5$
- D) $-11k^2 + 4k + 11$

Answer: B

167) Find $f(3)$ if $f = \{(-2, 3), (3, 0), (0, 5), (5, -2)\}$

- A) -2
- B) (0, -2)
- C) None of these
- D) 0

Answer: D

168) Find $f(12)$

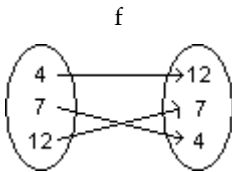

- A) None of these
- B) 4
- C) (7, 4)
- D) 7

Answer: D

The graph of $y = f(x)$ is given. Use the graph to find the function value.

169)

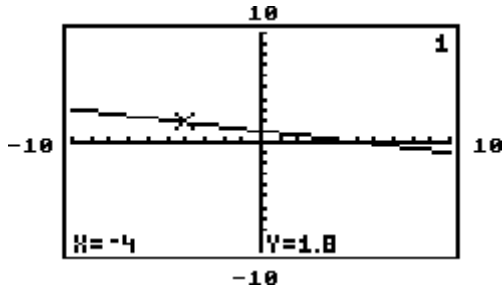

Find $f(-4)$.

- A) 1
- B) 1.8
- C) None of these
- D) -4

Answer: B

170)

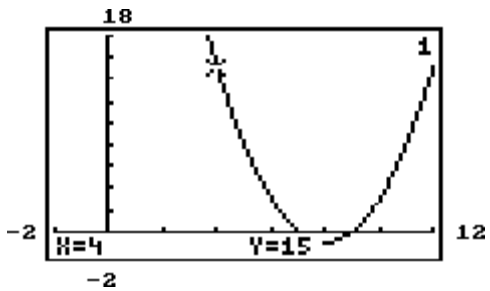

Find $f(4)$.

- A) 15
- B) 4
- C) -1
- D) None of these

Answer: A

171)

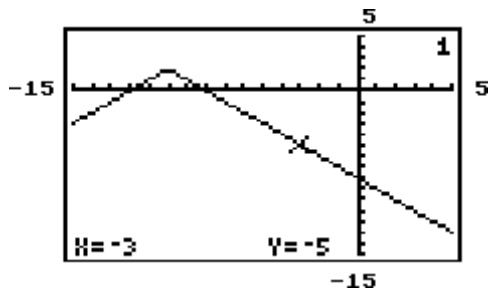

Find $f(-3)$.

- A) None of these
- B) 2
- C) -3
- D) -5

Answer: D

172) Find $f(-$

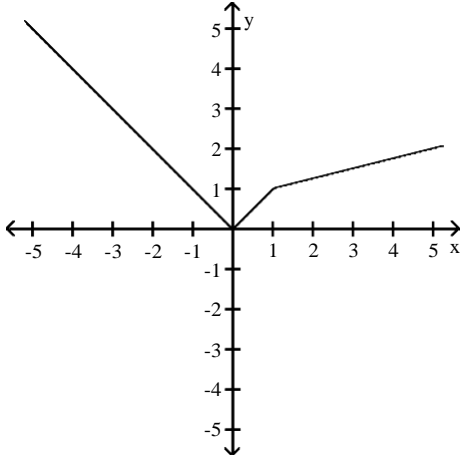

- A) 2
- B) 1.25
- C) 5
- D) -2

Answer: A

173) Find $f(5)$.

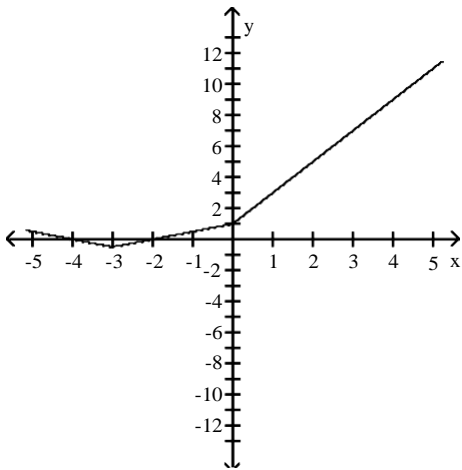

- A) 9
- B) -11
- C) 2
- D) 11

Answer: D

174) Find $f(-$

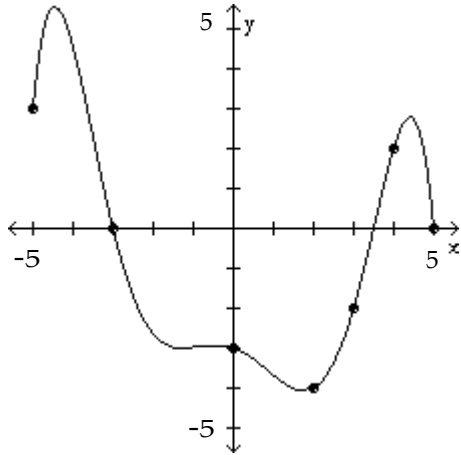

- A) -3
- B) 5
- C) -2
- D) 0

Answer: D

An equation that defines y as a function of x is given. Solve for y in terms of x , and replace y with the function notation $f(x)$.

175) $x - 2y = 14$

- A) $f(x) = -\frac{1}{2}x + 7$
- B) $f(x) = \frac{1}{2}x - 7$
- C) $f(x) = -x + 7$
- D) $f(x) = \frac{1}{2}x - 14$

Answer: B

176) $x + 7y = 7$

- A) $f(x) = 7x - 7$
- B) $f(x) = -\frac{1}{7}x + 1$
- C) $f(x) = \frac{1}{7}x + 1$
- D) $f(x) = -x + 1$

Answer: B

177) $y - 4x^2 = 7 - x$

- A) $f(x) = -4x^2 + x - 7$
- B) $f(x) = 4x^2 - x + 7$
- C) $f(x) = -4x^2 - x + 7$
- D) $f(x) = 4x^2 + x + 7$

Answer: B

- 178) $9x + 5y = 8$
- A) $f(x) = -\frac{9}{5}x + \frac{8}{5}$
- B) $f(x) = \frac{9}{5}x + \frac{8}{5}$
- C) $f(x) = \frac{9}{5}x - \frac{8}{5}$
- D) $f(x) = 9x - 8$

Answer: A

- 179) $5x - 2y = 3$
- A) $f(x) = 5x - 3$
- B) $f(x) = \frac{5}{2}x + \frac{3}{2}$
- C) $f(x) = \frac{5}{2}x - \frac{3}{2}$
- D) $f(x) = \frac{2}{5}x + \frac{3}{5}$

Answer: C

Determine the intervals of the domain for which the function is increasing, decreasing, and constant.

180)

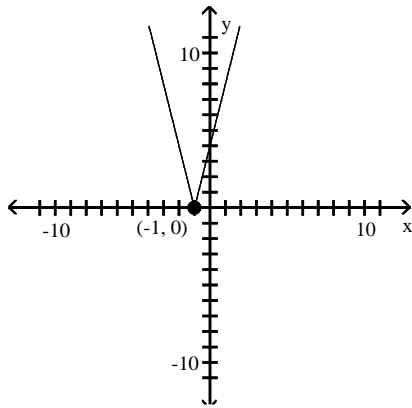

- A) Increasing $(-\infty, 1]$; Decreasing $[1, \infty)$
- B) Increasing $[1, \infty)$; Decreasing $(-\infty, 1]$
- C) Increasing $(-\infty, -1]$; Decreasing $[-1, \infty)$
- D) Increasing $[-1, \infty)$; Decreasing $(-\infty, -1]$

Answer: D

181)

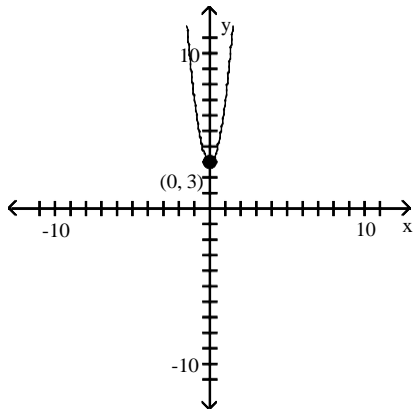

- A) Increasing $(-\infty, 0]$; Decreasing $[0, -\infty)$
- B) Increasing $(-\infty, 0]$; Decreasing $(-\infty, 0]$
- C) Increasing $[0, \infty)$; Decreasing $(-\infty, 0]$
- D) Increasing $(-\infty, 0]$; Decreasing $[0, \infty)$

Answer: C

182)

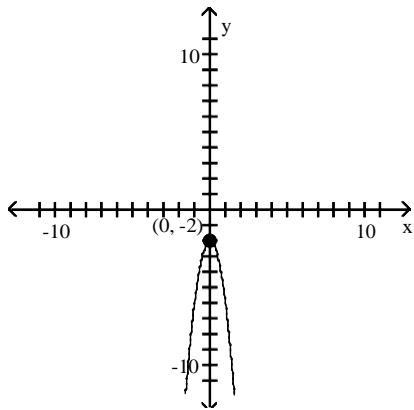

- A) Increasing $(-\infty, 0]$; Decreasing $(-\infty, 0]$
- B) Increasing $(-\infty, 0]$; Decreasing $[0, \infty)$
- C) Increasing $[0, \infty)$; Decreasing $(-\infty, 0]$
- D) Increasing $(-\infty, 0]$; Decreasing $[0, -\infty)$

Answer: B

183)

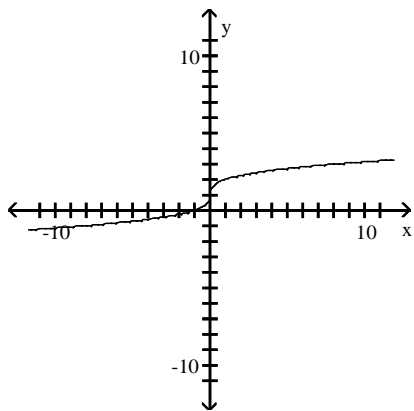

- A) Increasing $[0, \infty)$; Decreasing $(-\infty, 0]$
- B) Increasing $(-\infty, 0]$; Decreasing $[0, \infty)$
- C) Increasing for all reals; Decreasing never
- D) Increasing never; Decreasing for all reals

Answer: C

184)

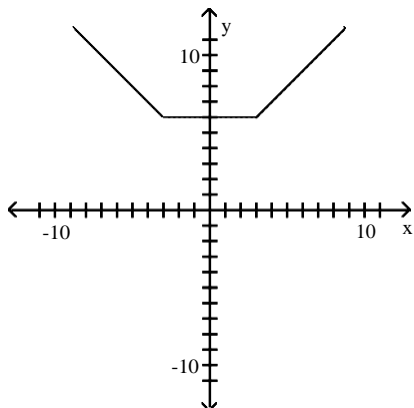

- A) Increasing $[3, \infty)$; Decreasing $[-3, \infty)$; Constant $(-3, 3)$
- B) Increasing $(-\infty, 3]$; Decreasing $(-\infty, -3]$; Constant $(-3, 3)$
- C) Increasing $(-\infty, 3]$; Decreasing $[-3, \infty)$; Constant $[-3, 3]$
- D) Increasing $[3, \infty)$; Decreasing $(-\infty, -3]$; Constant $[-3, 3]$

Answer: D

185)

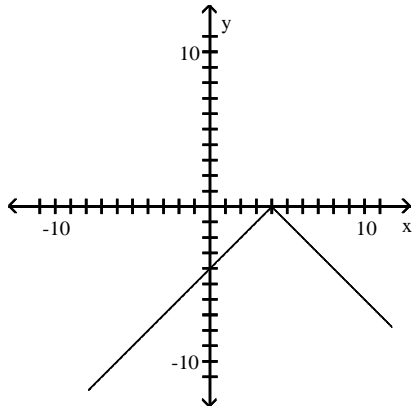

- A) Increasing $[4, \infty)$; Decreasing $(-\infty, 4]$
- B) Increasing $(-\infty, 4]$; Decreasing $(-\infty, 4]$
- C) Increasing $(-\infty, 4]$; Decreasing $[4, \infty)$
- D) Increasing $[4, \infty)$; Decreasing $[4, \infty)$

Answer: C

186)

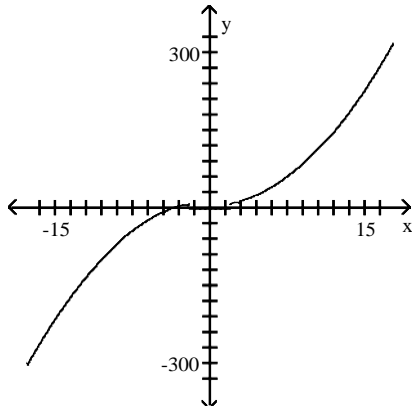

- A) Increasing never; Decreasing $(-\infty, -2) \cup (2, \infty)$
- B) Increasing $(-\infty, -2) \cup (2, \infty)$; Decreasing never
- C) Increasing $(2, \infty)$; Decreasing $(-\infty, -2)$
- D) Increasing $(-2, 2)$; Decreasing $(-\infty, -2) \cup (2, \infty)$

Answer: B

Use the graph to solve the problem.

187) The height h in feet of a projectile thrown upward from the roof of a building after time t seconds is shown in the graph below. How high will the projectile be after 2.2 s?

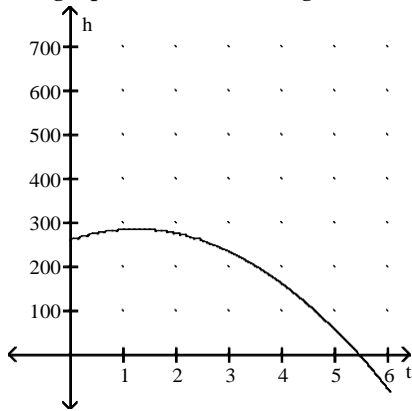

- A) 250 ft
- B) 325 ft
- C) 300 ft
- D) 275 ft

Answer: D

188) The surface area a of a cylinder is shown in the graph below. What is the radius r if the surface area is 5 m^2 ?

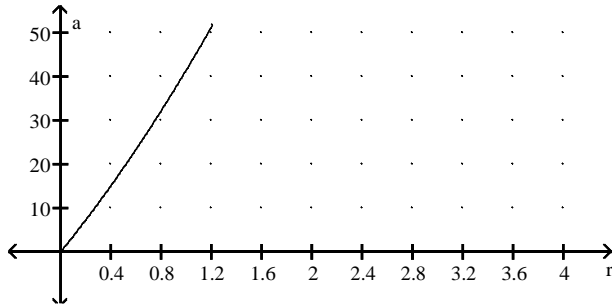

- A) -0.2 m
- B) 0.0 m
- C) 0.4 m
- D) 0.2 m

Answer: D

189) The graph shows the relationship between current I and resistance R if the voltage is fixed. Find the current if the resistance is 1.1Ω .

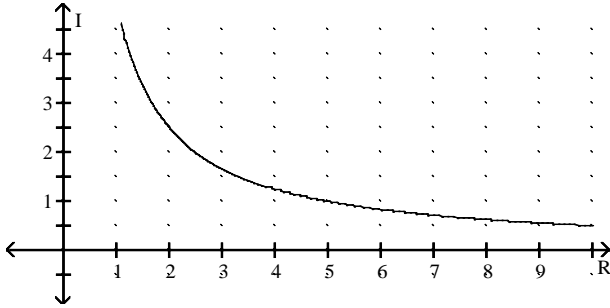

- A) 4.4 A
- B) 4.2 A
- C) 4.8 A
- D) 4.6 A

Answer: D

190) The graph shows the relationship between the area A of a rectangle and the length L , if the width is fixed. Find the area if the length is 6 cm.

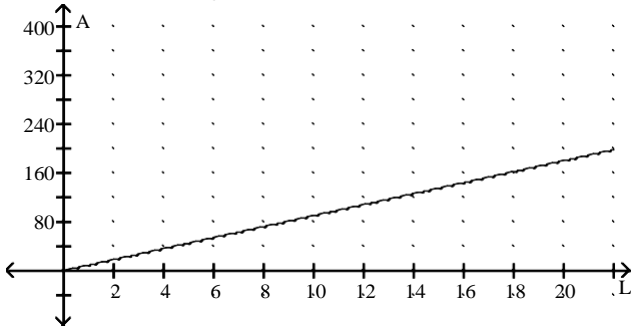

- A) 36 cm^2
- B) 18 cm^2
- C) 54 cm^2
- D) 27 cm^2

Answer: C

The line graph shows the recorded hourly temperatures in degrees Fahrenheit at an airport.

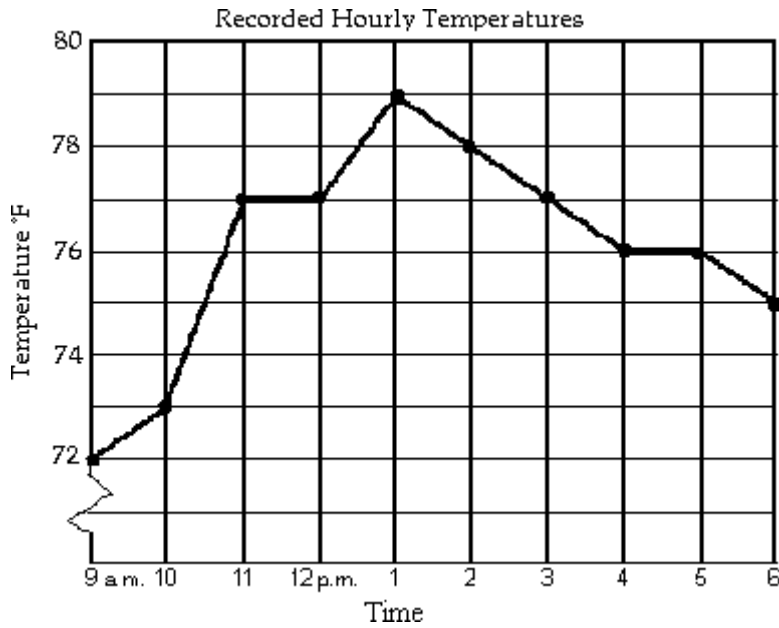

191) At what time was the temperature the highest?

- A) 11 a.m.
- B) 1 p.m.
- C) 5 p.m.
- D) 2 p.m.

Answer: B

192) At what time was the temperature its lowest?

- A) 9 a.m.
- B) 6 p.m.
- C) 1 p.m.
- D) 4 p.m.

Answer: A

193) What temperature was recorded at 1 p.m.?

- A) 81 °F
- B) 79 °F
- C) 80 °F
- D) 77 °F

Answer: B

194) During which hour did the temperature increase the most?

- A) 12 p.m. to 1 p.m.
- B) 10 a.m. to 11 a.m.
- C) 1 p.m. to 2 p.m.
- D) 9 a.m. to 10 a.m.

Answer: B

195) At what time was the temperature 73°?

- A) 10 a.m. and 11 a.m.
- B) 10 a.m.
- C) 4 p.m. and 5 p.m.
- D) 5 p.m.

Answer: B

196) During which two hour period did the temperature increase the most?

- A) 10 a.m. to 12 p.m.
- B) 10 a.m. to 11 a.m.
- C) 9 a.m. to 11 a.m.
- D) 12 p.m. to 2 p.m.

Answer: C

197) At what times was the temperature higher than 77°F?

- A) from 11 a.m. until 3 p.m.
- B) from 12 p.m. until 1 p.m.
- C) from 12 p.m. until 3 p.m.
- D) after 12 p.m.

Answer: C

198) At what times was the temperature below 77°F?

- A) from 9 a.m. until 11 a.m. and from 3 p.m. until 6 p.m.
- B) from 9 a.m. until 12 p.m. and from 3 p.m. until 6 p.m.
- C) after 3 p.m.
- D) from 12 p.m. until 3 p.m.

Answer: A

Match the description with the correct symbolic expression.

199) a linear function whose graph has a slope of 7

- A) $y = 7x + 6$
- B) $x = 7$
- C) $7x - 6y = 6$
- D) $f(x) = -7x + 7$

Answer: A

200) a linear function whose graph has y-intercept -2

- A) $f(x) = -5x - 2$
- B) $-2x + 8y = 3$
- C) $y = -2x + 3$
- D) $x = -2$

Answer: A

201) a vertical line

- A) $f(x) = -9x + 5$
- B) $5x - 6y = 7$
- C) $x = 5$
- D) $y = 5x + 7$

Answer: C

202) a constant function

- A) $f(x) = -5$
- B) $y = -7x + 9$
- C) $-7x + 9y = 9$
- D) $x = -7$

Answer: A

203) a linear equation whose graph has x-intercept -7 and y-intercept 58

- A) $y = 58x + 406$
- B) $-58x + 7y = 406$
- C) $x = 58$
- D) $f(x) = -7$

Answer: B

204) a linear function whose graph passes through the origin

- A) $x = 5$
- B) $f(x) = 5$
- C) $9x - 9y = 9$
- D) $y = -4x$

Answer: D

205) a line with a negative slope

- A) $f(x) = 5x - 1$
- B) $5x + 9y = -7$
- C) $y = -7$
- D) $x = -1$

Answer: B

206) a function that is not linear

- A) $f(x) = 8x + 5$
- B) $f(x) = x^5 - 5$
- C) $f(x) = -1$
- D) $f(x) = -5x + 8$

Answer: B

207) a line with a positive slope

- A) $y = x^{13}$
- B) $-11x + 7y = 13$
- C) $y = -4x + 13$
- D) $x = -4$

Answer: B

208) a horizontal line

- A) $y = -9x + 8$
- B) $8x + 13y = -2$
- C) $f(x) = 13$
- D) $x = -9$

Answer: C

Graph the linear function and give the domain and the range. If the function is a constant function, identify it as such.

209) $f(x) = 3x + 5$

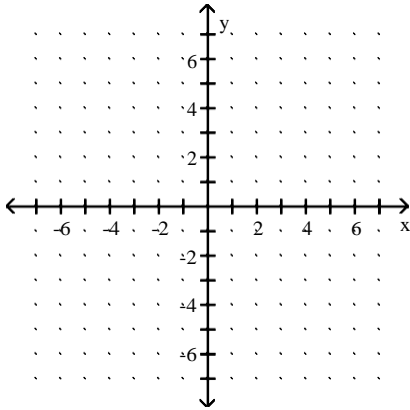

A) $D = (-\infty, \infty), R = (-\infty, \infty)$

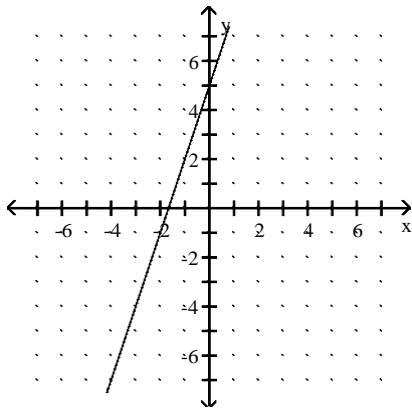

B) $D = (-\infty, \infty), R = (-\infty, \infty)$

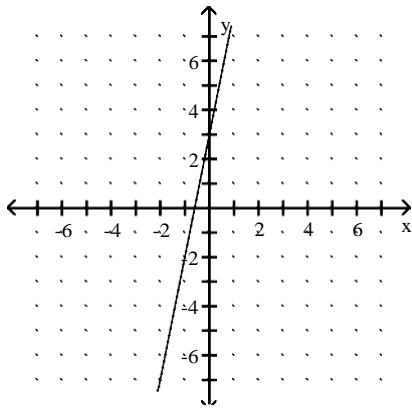

C) $D = (-\infty, \infty), R = (-\infty, \infty)$

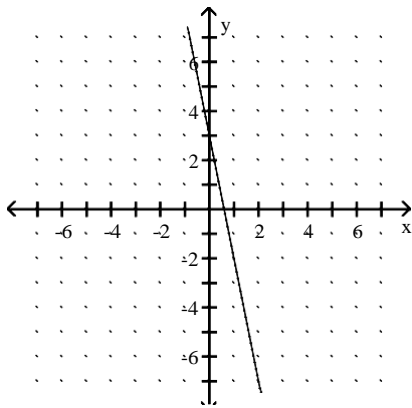

D) $D = (-\infty, \infty)$, $R = (-\infty, \infty)$

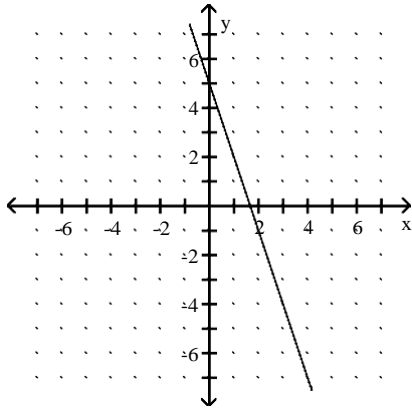

Answer: A

210) $g(x) = x - 4$

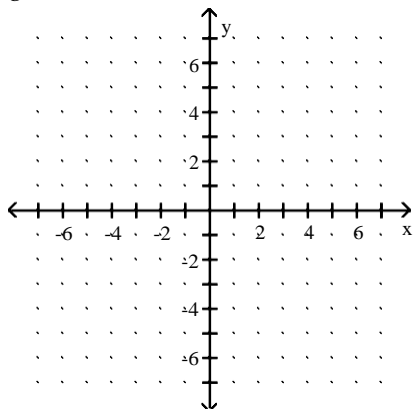

A) $D = (-\infty, \infty)$, $R = (-\infty, \infty)$

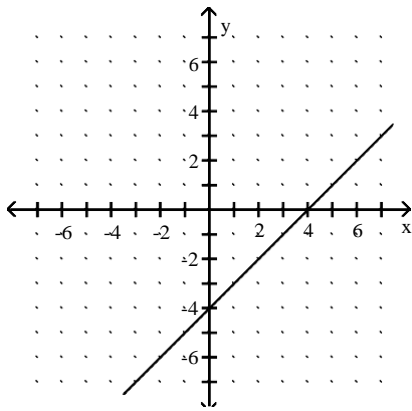

B) $D = (-\infty, \infty)$, $R = (-\infty, \infty)$

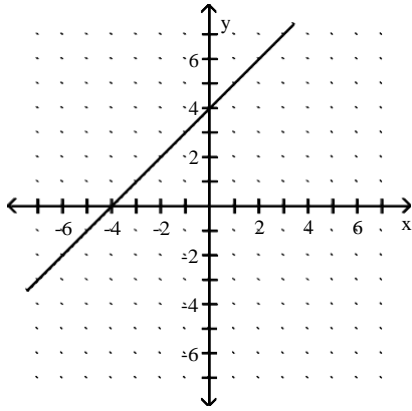

C) $D = (-\infty, \infty)$, $R = (-\infty, \infty)$

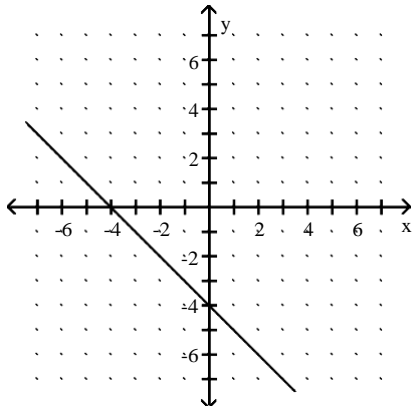

D) $D = (-\infty, \infty)$, $R = (-\infty, \infty)$

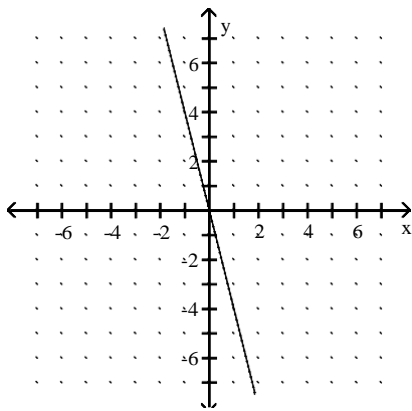

Answer: A

211) $3x - 9y = 9$

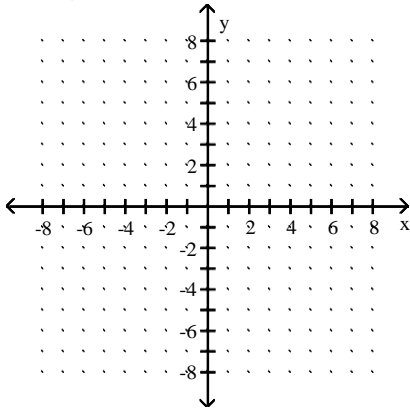

A) $D = (-\infty, \infty)$, $R = (-\infty, \infty)$

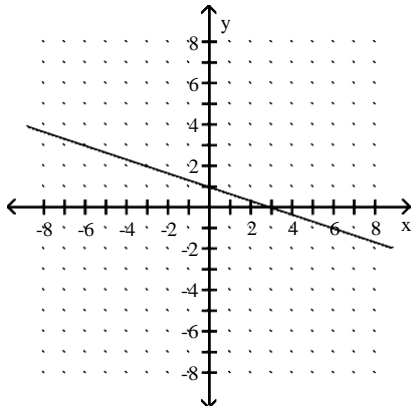

B) $D = (-\infty, \infty)$, $R = (-\infty, \infty)$

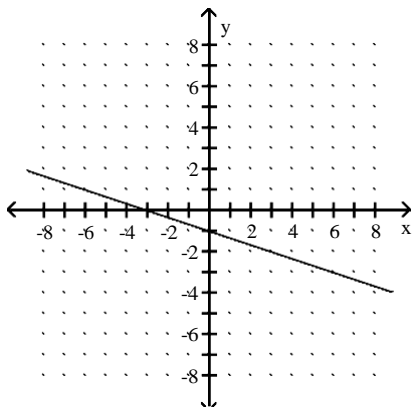

C) $D = (-\infty, \infty)$, $R = (-\infty, \infty)$

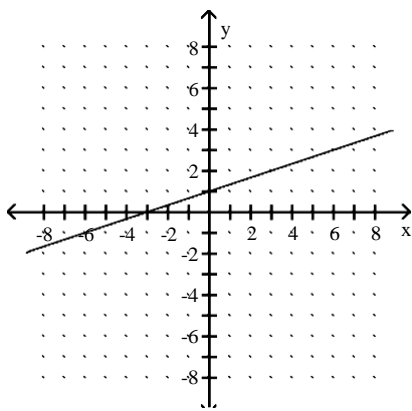

D) $D = (-\infty, \infty)$, $R = (-\infty, \infty)$

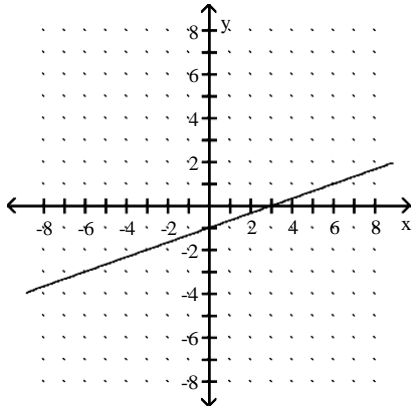

Answer: D

212) $5x - 10y = 0$

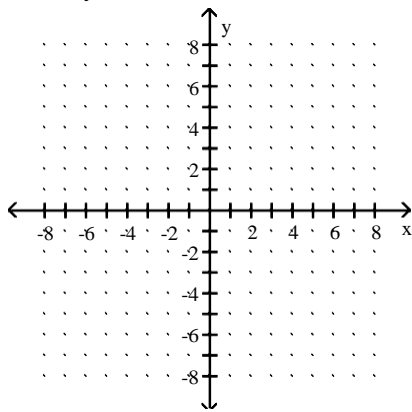

A) $D = (-\infty, \infty)$, $R = (-\infty, \infty)$

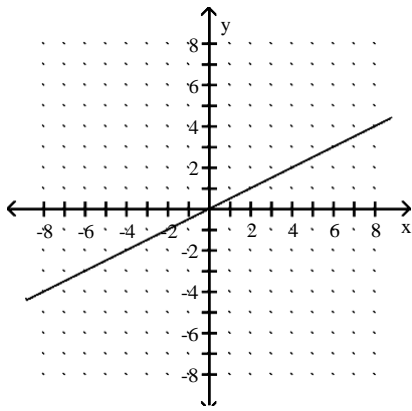

B) $D = (-\infty, \infty)$, $R = (-\infty, \infty)$

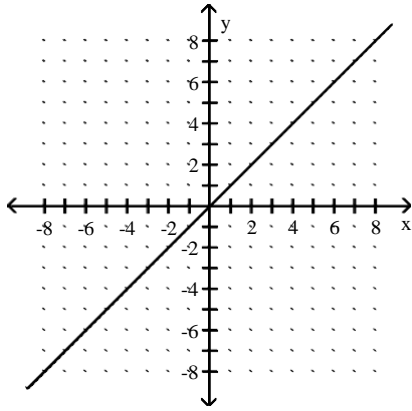

C) $D = (-\infty, \infty)$, $R = (-\infty, \infty)$

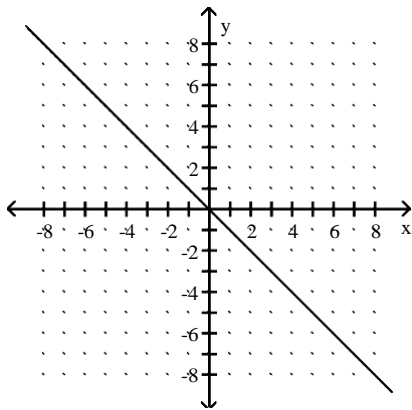

D) $D = (-\infty, \infty)$, $R = (-\infty, \infty)$

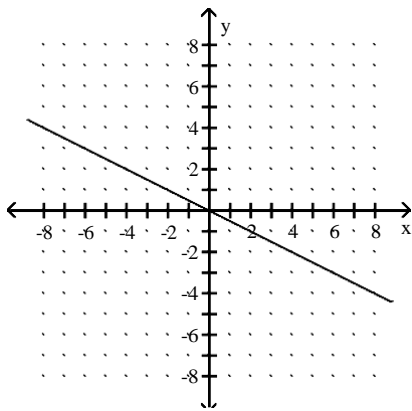

Answer: A

213) $h(x) = -2x$

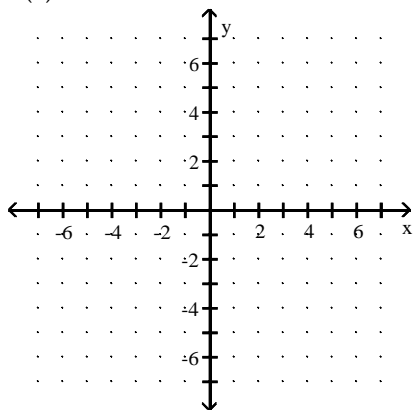

A) $D = (-\infty, \infty), R = (-\infty, \infty)$

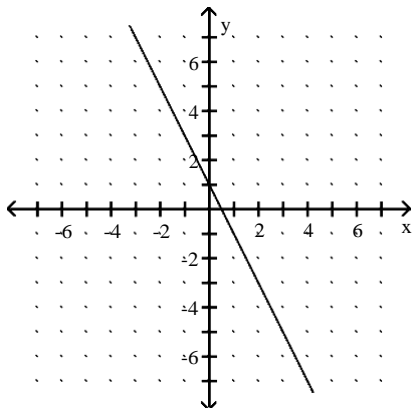

B) $D = (-\infty, \infty), R = (-\infty, \infty)$

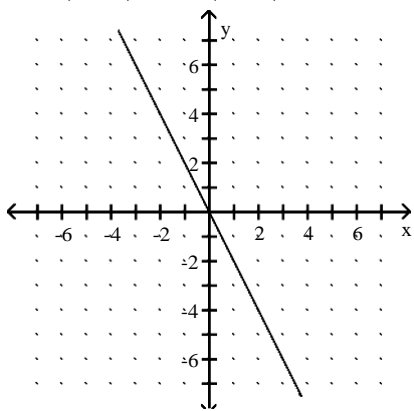

C) $D = (-\infty, \infty), R = (-\infty, \infty)$

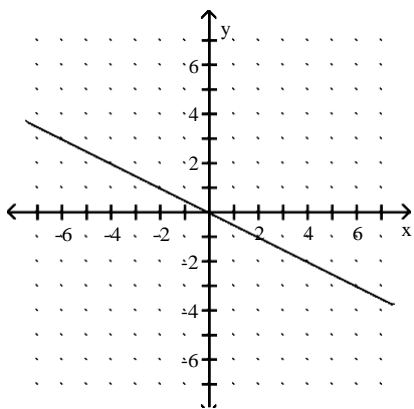

D) $D = (-\infty, \infty)$, $R = (-\infty, \infty)$

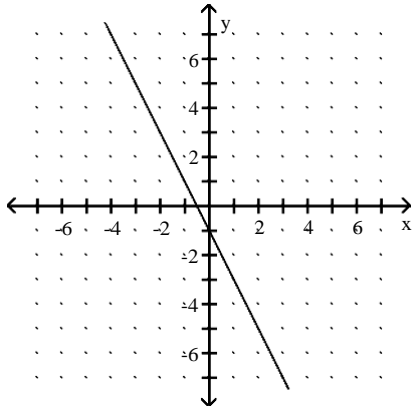

Answer: B

214) $f(x) = \frac{1}{5}x + 6$

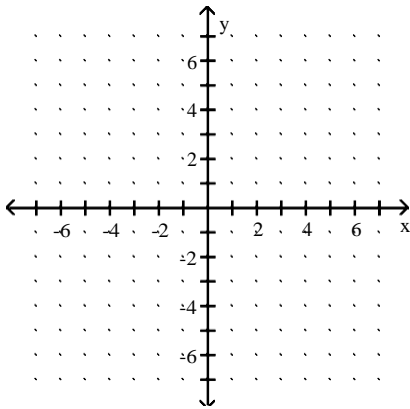

A) $D = (-\infty, \infty)$, $R = (-\infty, \infty)$

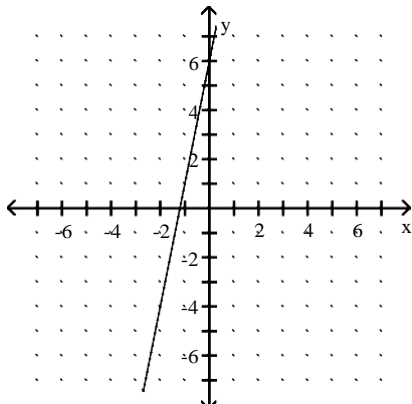

B) $D = (-\infty, \infty)$, $R = (-\infty, \infty)$

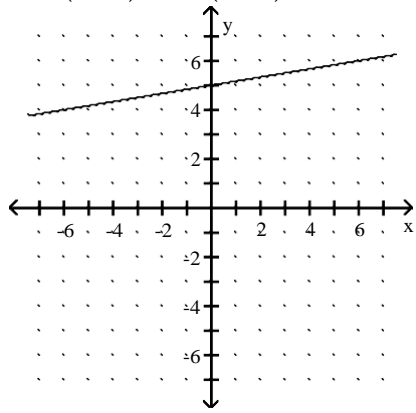

C) $D = (-\infty, \infty)$, $R = (-\infty, \infty)$

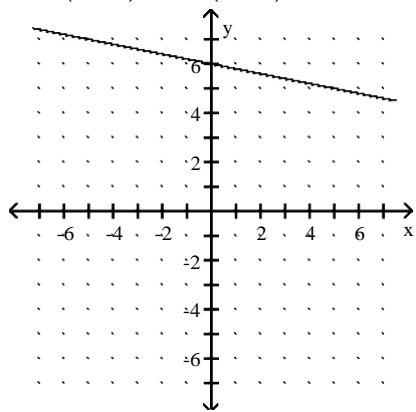

D) $D = (-\infty, \infty)$, $R = (-\infty, \infty)$

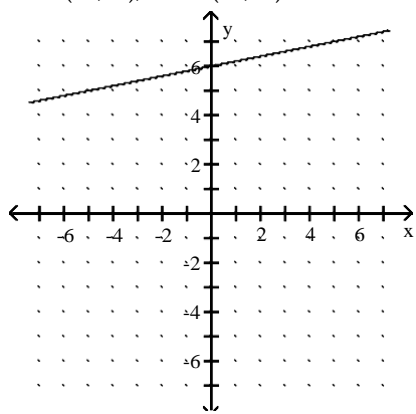

Answer: D

215) $f(x) = \frac{1}{4}x$

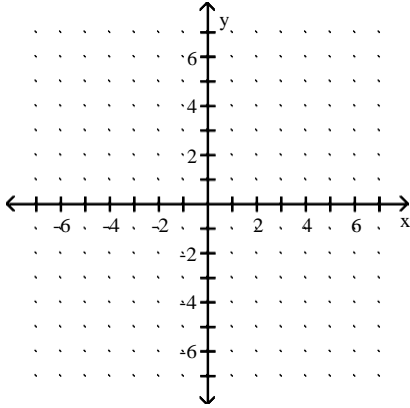

A) $D = (-\infty, \infty), R = (-\infty, \infty)$

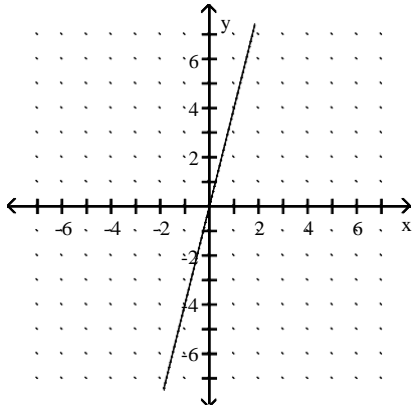

B) $D = (-\infty, \infty), R = (-\infty, \infty)$

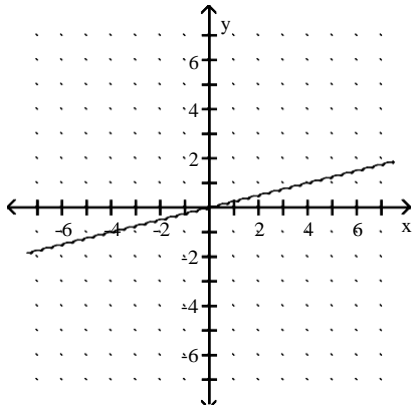

C) $D = (-\infty, \infty), R = (-\infty, \infty)$

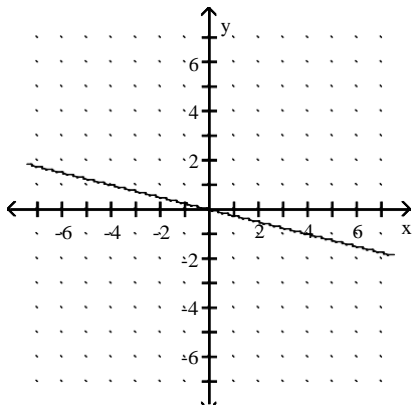

D) $D = (-\infty, \infty)$, $R = (-\infty, \infty)$

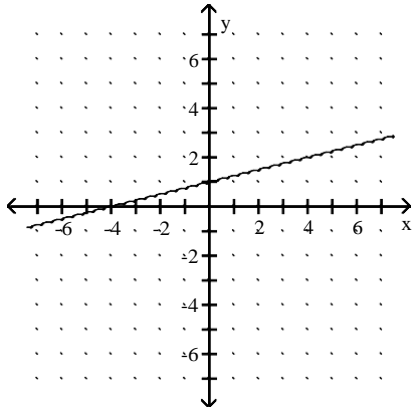

Answer: B

216) $h(x) = -2$

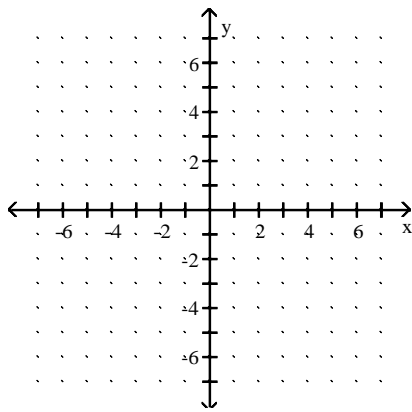

A) $D = \{-2\}$, $R = (-\infty, \infty)$

constant function

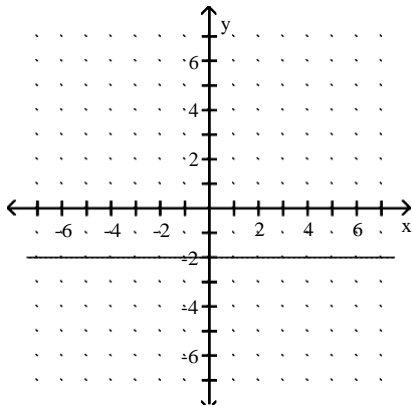

B) $D = \{-2\}, R = (-\infty, \infty)$

constant function

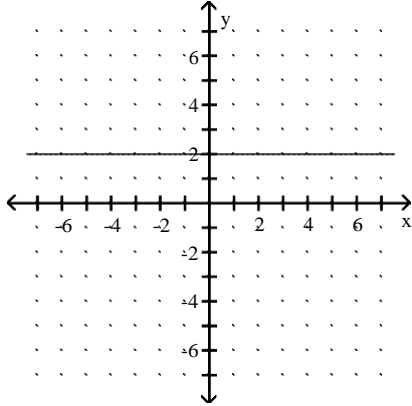

C) $D = (-\infty, \infty), R = \{-2\}$

constant function

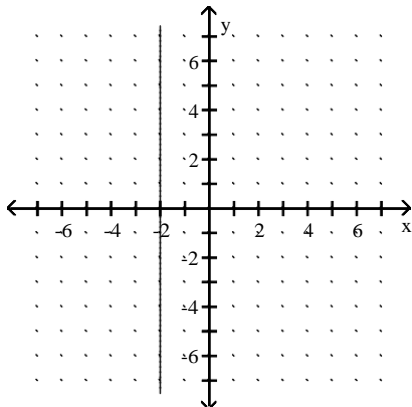

D) $D = (-\infty, \infty), R = \{-2\}$

constant function

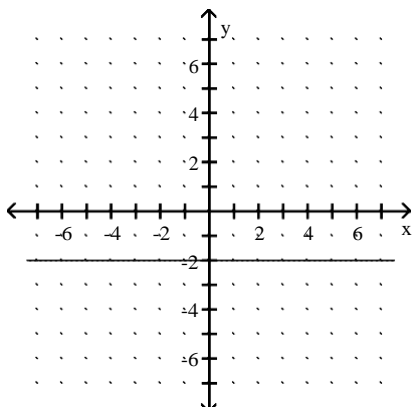

Answer: D

Graph the line and give the domain and the range.

217) $y = -6$

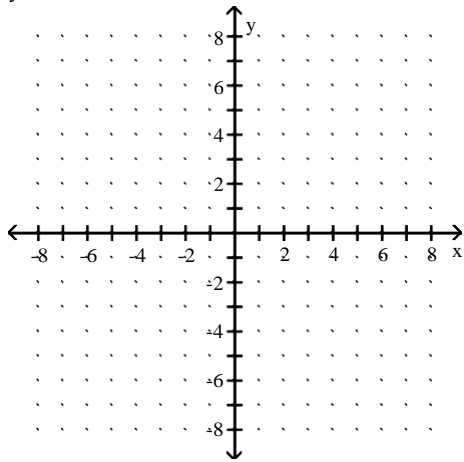

A) $D = (-\infty, \infty)$, $R = \{-6\}$

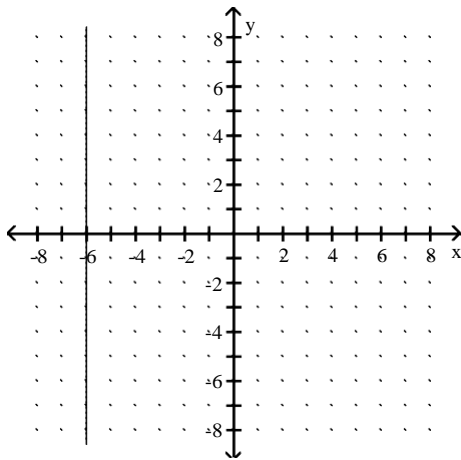

B) $D = \{-6\}$, $R = (-\infty, \infty)$

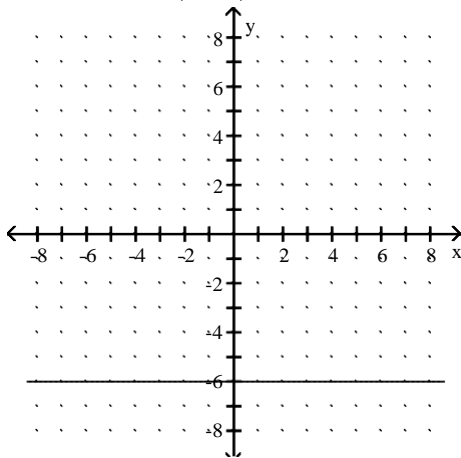

C) $D = \{-6\}$, $R = (-\infty, \infty)$

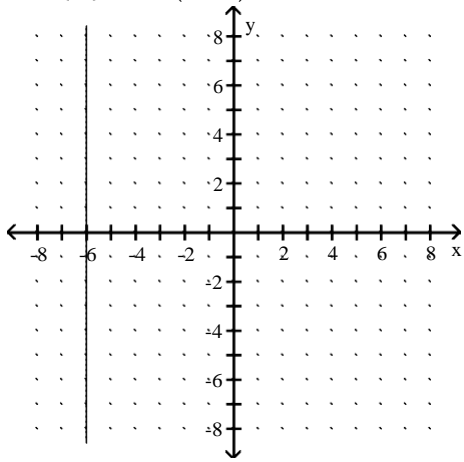

D) $D = (-\infty, \infty)$, $R = \{-6\}$

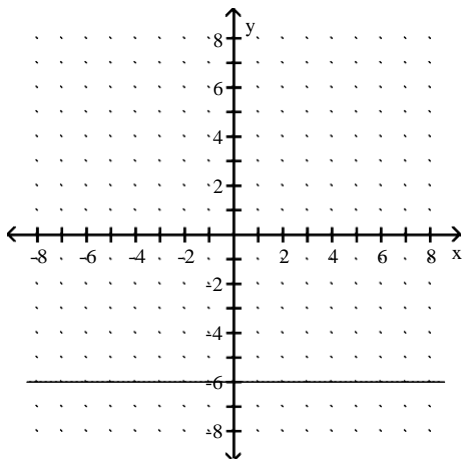

Answer: D

218) $x = 1$

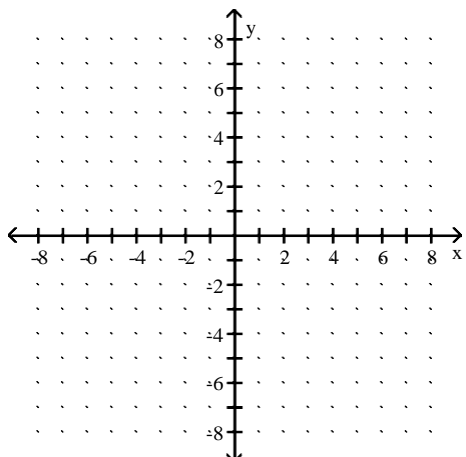

A) $D = \{1\}$, $R = (-\infty, \infty)$

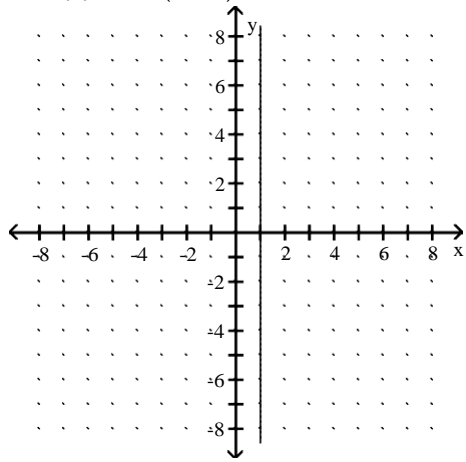

B) $D = (-\infty, \infty)$, $R = \{1\}$

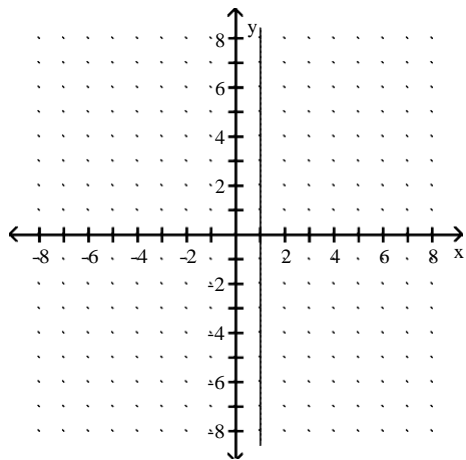

C) $D = \{1\}$, $R = (-\infty, \infty)$

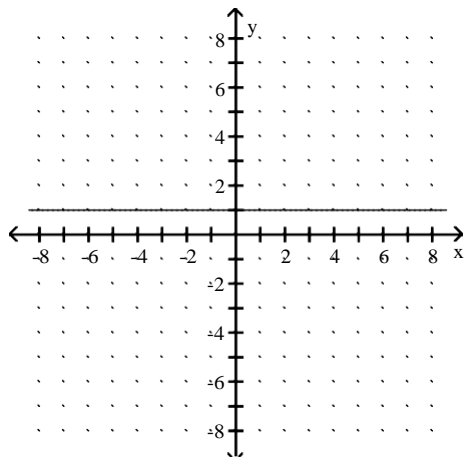

D) $D = (-\infty, \infty)$, $R = \{1\}$

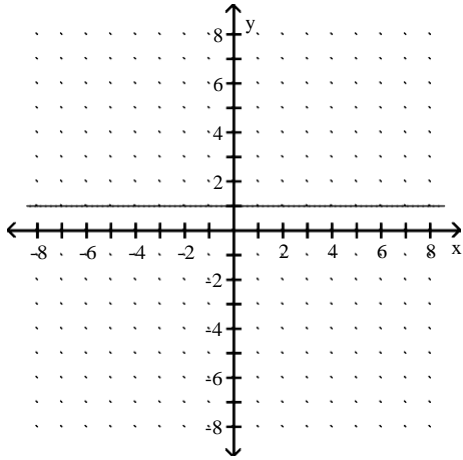

Answer: A

219) $x + 1 = 0$

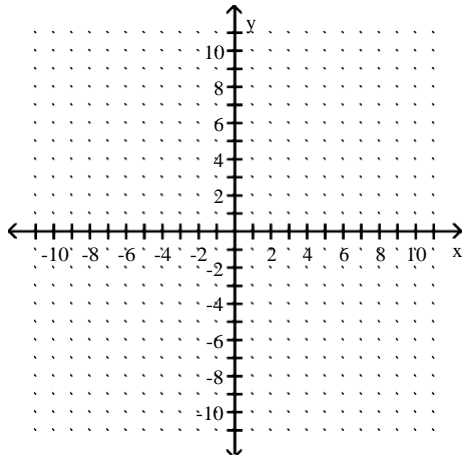

A) $D = (-\infty, \infty)$, $R = \{-1\}$

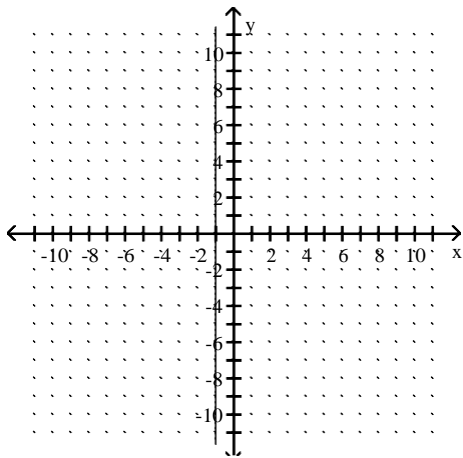

B) $D = (-\infty, \infty)$, $R = \{-1\}$

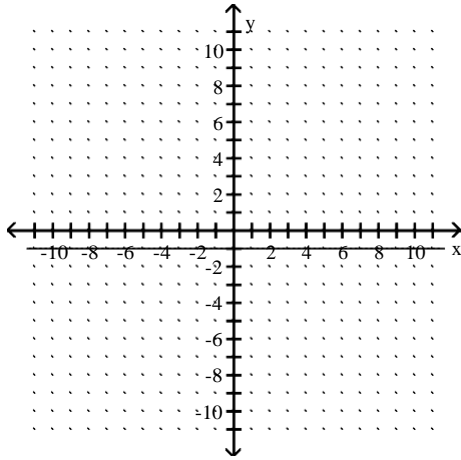

C) $D = (-\infty, \infty)$, $R = (-\infty, \infty)$

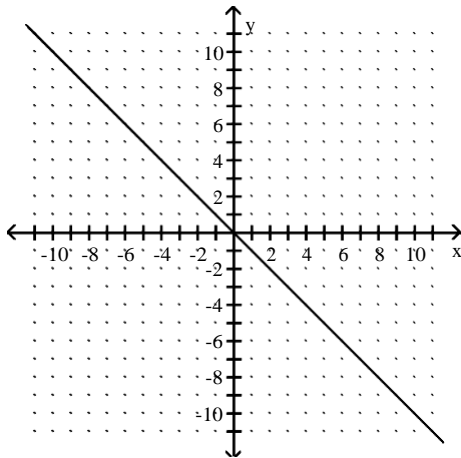

D) $D = \{-1\}$, $R = (-\infty, \infty)$

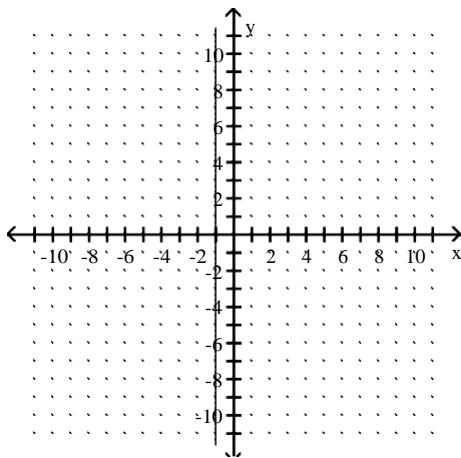

Answer: D

220) $y - 5 = 0$

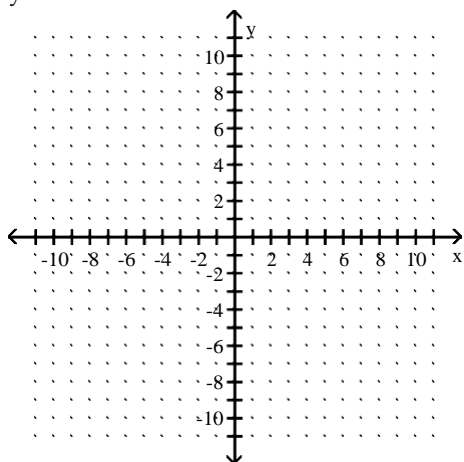

A) $D = (-\infty, \infty)$, $R = \{5\}$

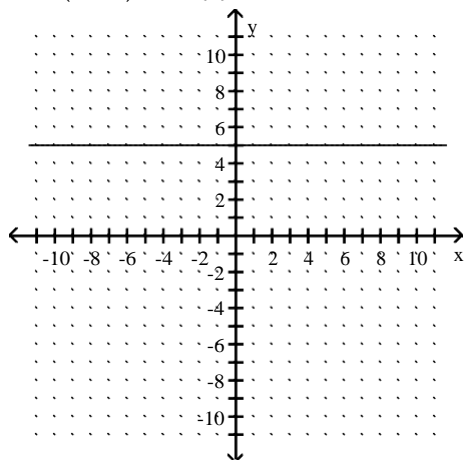

B) $D = (-\infty, \infty)$, $R = (-\infty, \infty)$

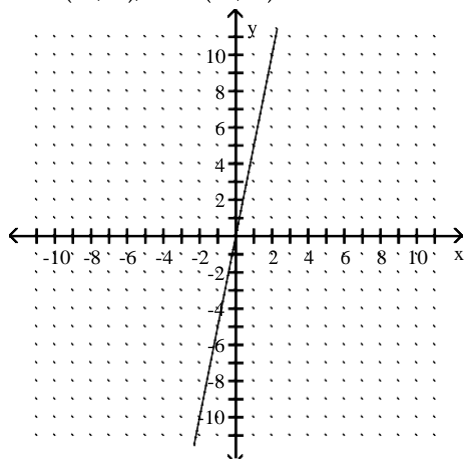

C) $D = \{5\}$, $R = (-\infty, \infty)$

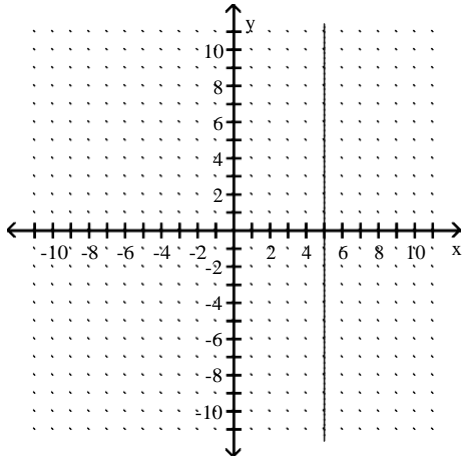

D) $D = (-\infty, \infty)$, $R = \{5\}$

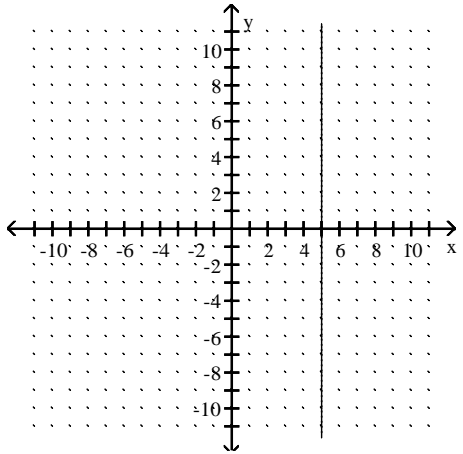

Answer: A

221) $-2x + 16 = 0$

A) $D = (-\infty, \infty)$, $R = \{-8\}$

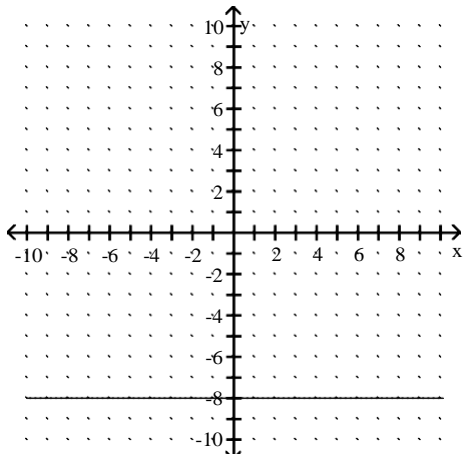

B) $D = \{8\}$, $R = (-\infty, \infty)$

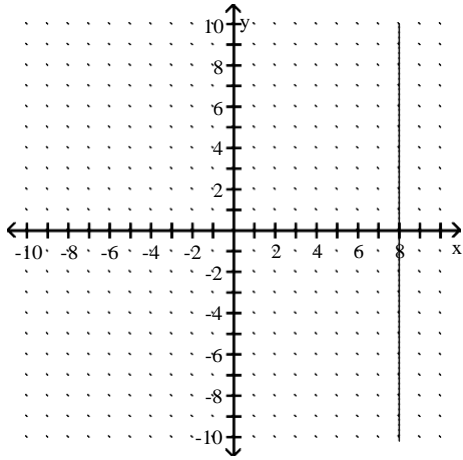

C) $D = \{-8\}$, $R = (-\infty, \infty)$

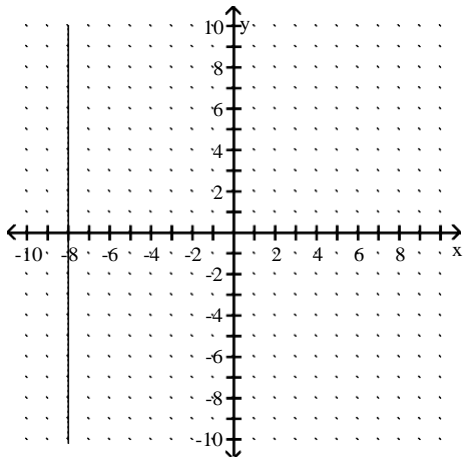

D) $D = (-\infty, \infty)$, $R = \{8\}$

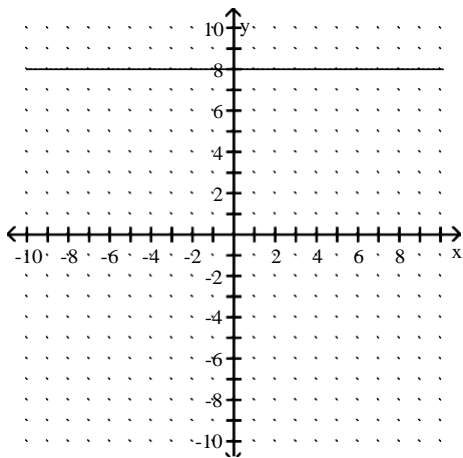

Answer: B

222) $2y + 12 = 0$

A) $D = \{-6\}, R = (-\infty, \infty)$

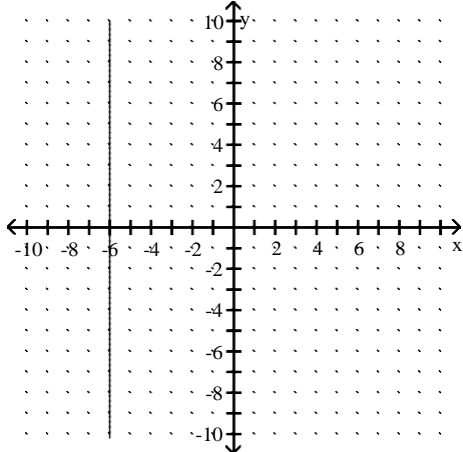

B) $D = (-\infty, \infty), R = \{-6\}$

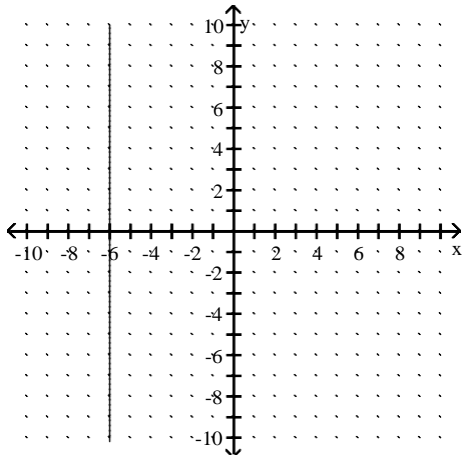

C) $D = \{-6\}, R = (-\infty, \infty)$

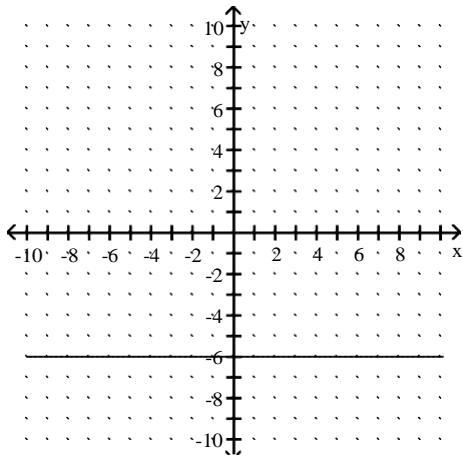

D) $D = (-\infty, \infty)$, $R = \{-6\}$

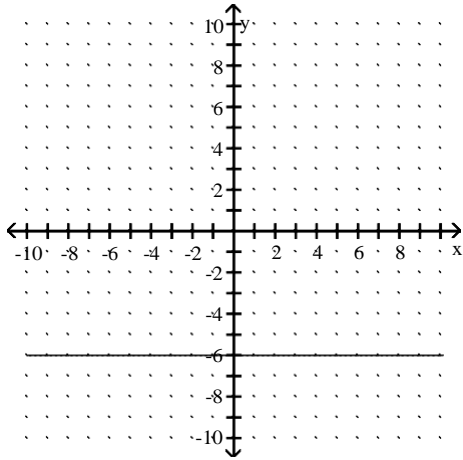

Answer: D

Find the slope of the line satisfying the given conditions.

223) through $(-5, -8)$ and $(8, -7)$

A) 13

B) $\frac{1}{13}$

C) $-\frac{1}{13}$

D) -13

Answer: B

224) through $(2, -9)$ and $(-1, 5)$

A) $-\frac{14}{3}$

B) $\frac{14}{3}$

C) $-\frac{3}{14}$

D) $\frac{3}{14}$

Answer: A

225) through $(-3, -6)$ and $(-2, -8)$

A) -2

B) 2

C) $-\frac{1}{2}$

D) $\frac{1}{2}$

Answer: A

226) through (6, -9) and (-5, -7)

A) $-\frac{11}{2}$

B) $-\frac{2}{11}$

C) $\frac{2}{11}$

D) $\frac{11}{2}$

Answer: B

227) through (-8, -6) and (-8, 5)

A) 11

B) -11

C) undefined

D) 0

Answer: C

228) through (-7, 2) and (-2, 2)

A) -5

B) 0

C) 5

D) undefined

Answer: B

229) vertical, through (-7, 3)

A) 1

B) -1

C) 0

D) undefined

Answer: D

230) horizontal, through (-5, 1)

A) undefined

B) -1

C) 0

D) 1

Answer: C

Find the slope of the line and sketch the graph.

231) $y - 4 = 0$

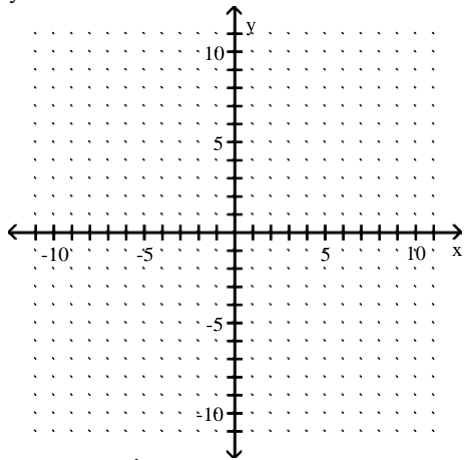

A) $m = \frac{1}{4}$

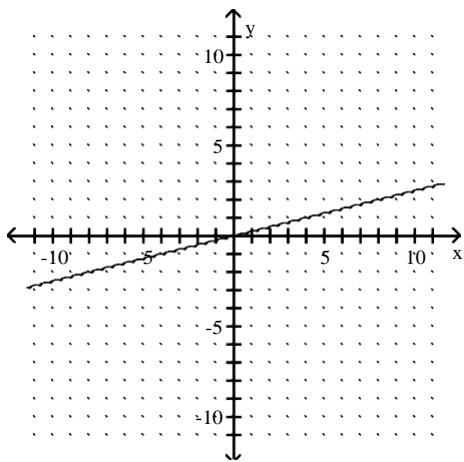

B) $m = 4$

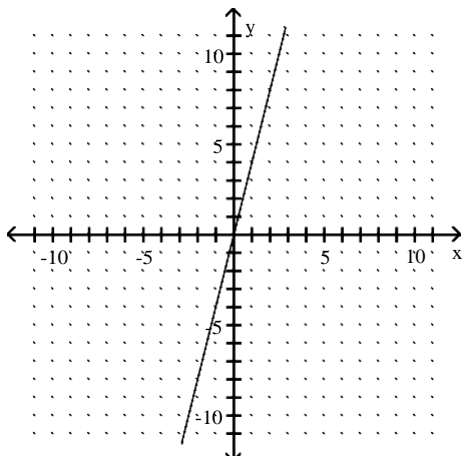

C) $m = 0$

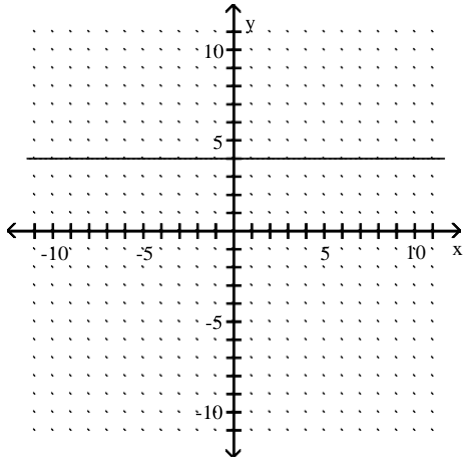

D) m : undefined

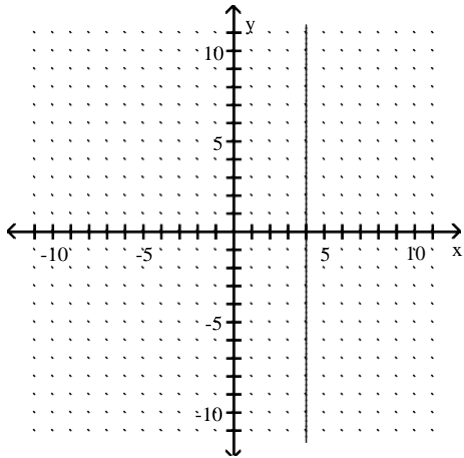

Answer: C

232) $y = -3x$

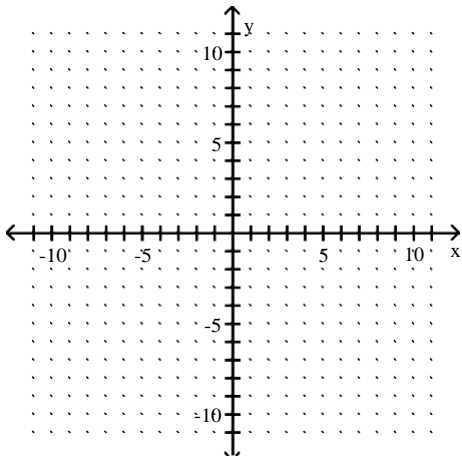

A) $m = 0$

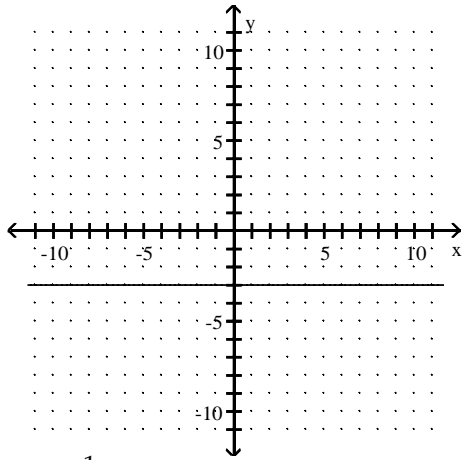

B) $m = -\frac{1}{3}$

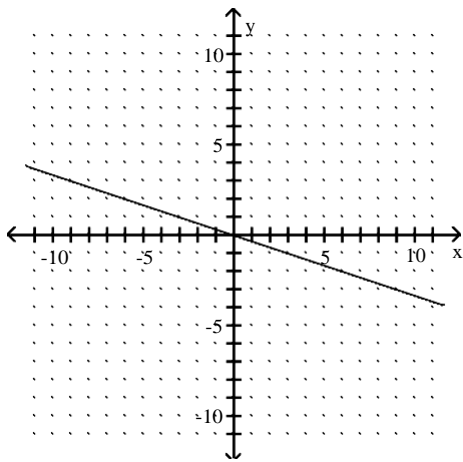

C) $m = 3$

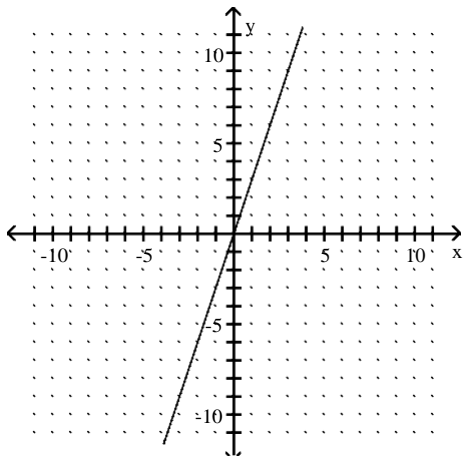

D) $m = -3$

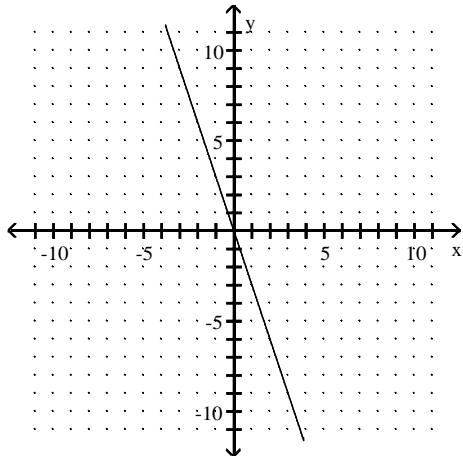

Answer: D

233) $y = 4x - 1$

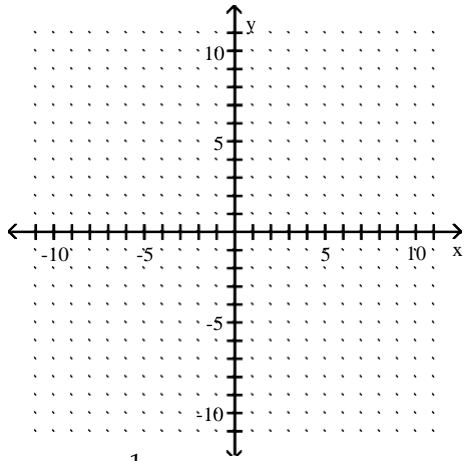

A) $m = \frac{1}{4}$

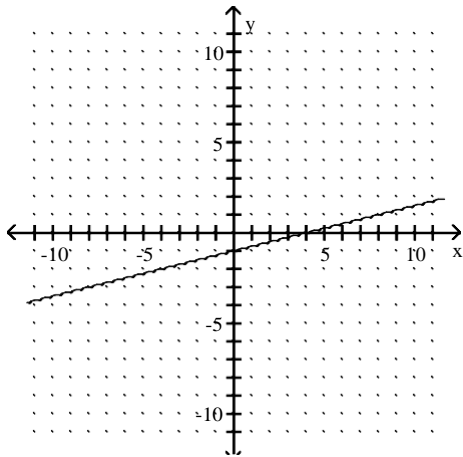

B) $m = 4$

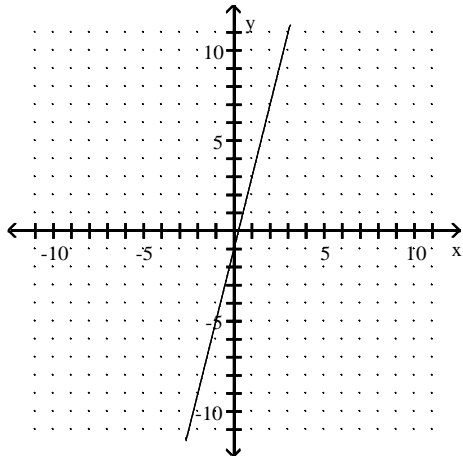

C) $m = -1$

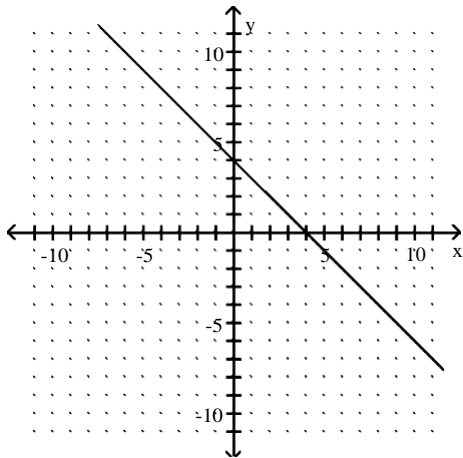

D) $m = -4$

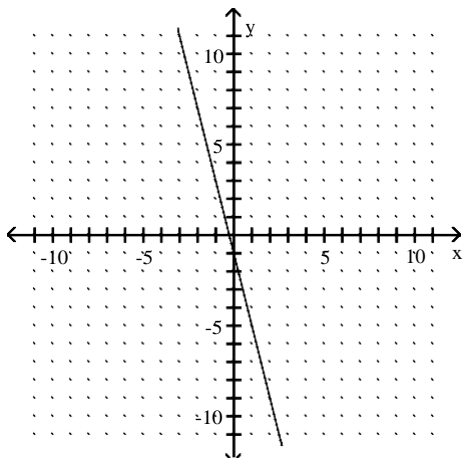

Answer: B

234) $-3y = 2x$

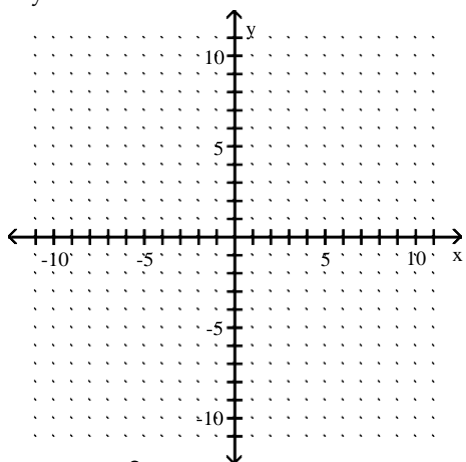

A) $m = \frac{2}{3}$

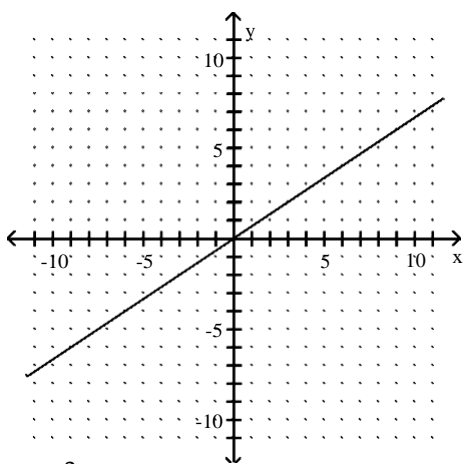

B) $m = \frac{3}{2}$

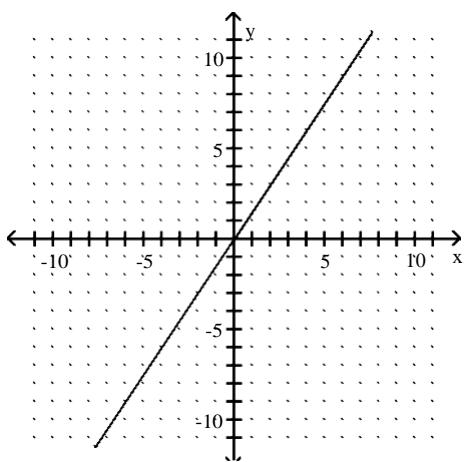

C) $m = -\frac{2}{3}$

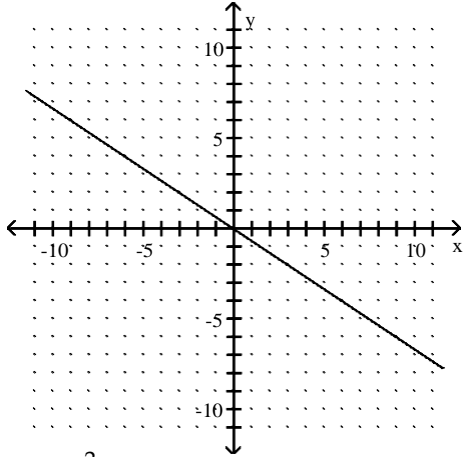

D) $m = -\frac{3}{2}$

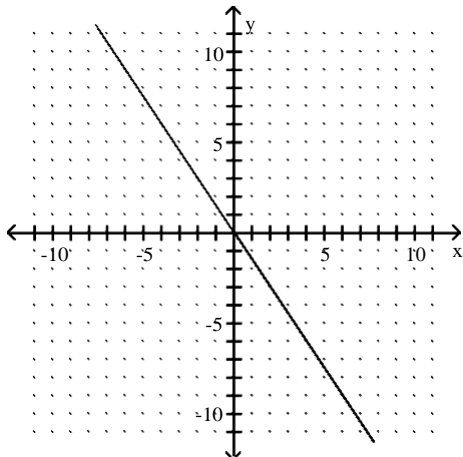

Answer: C

235) $3x + 5y = 29$

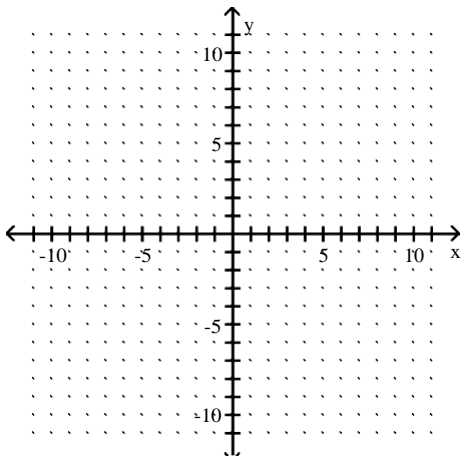

A) $m = \frac{3}{5}$

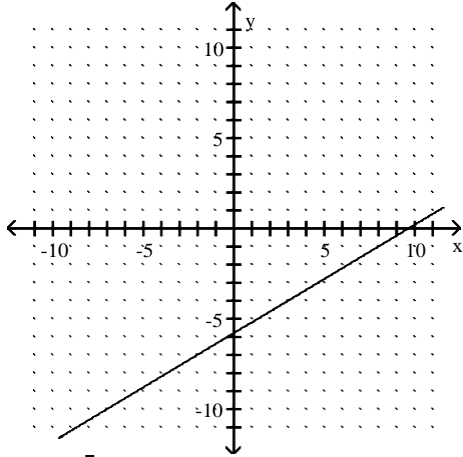

B) $m = -\frac{5}{3}$

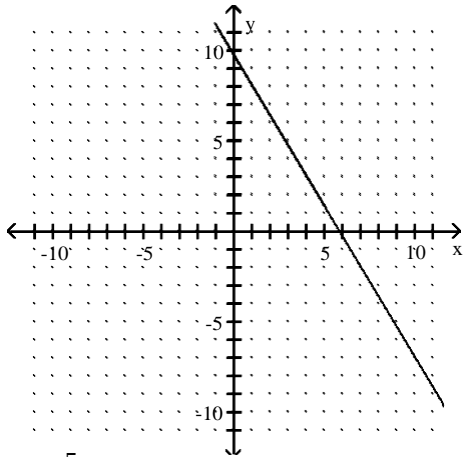

C) $m = \frac{5}{3}$

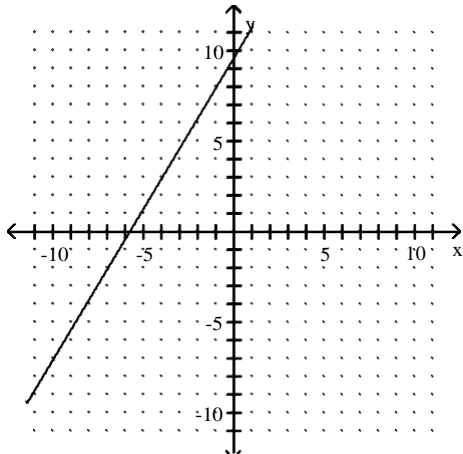

D) $m = -\frac{3}{5}$

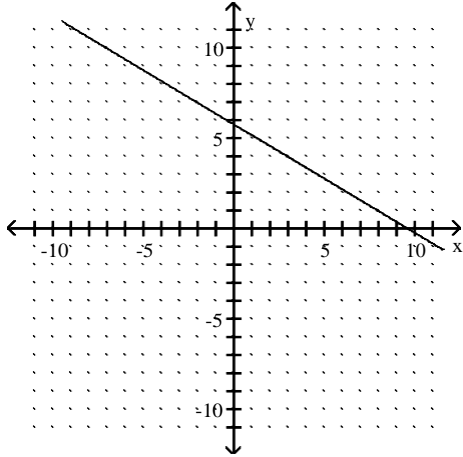

Answer: D

236) $2x - 5y = -6$

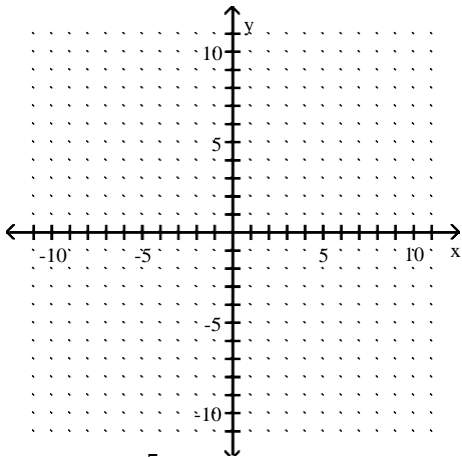

A) $m = -\frac{5}{2}$

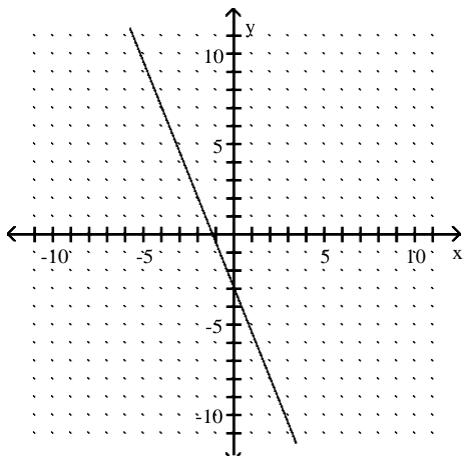

B) $m = -\frac{2}{5}$

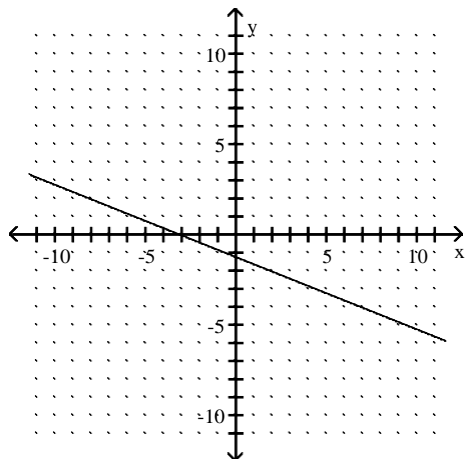

C) $m = \frac{2}{5}$

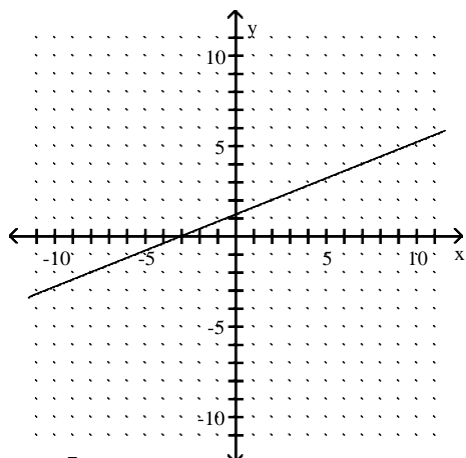

D) $m = \frac{5}{2}$

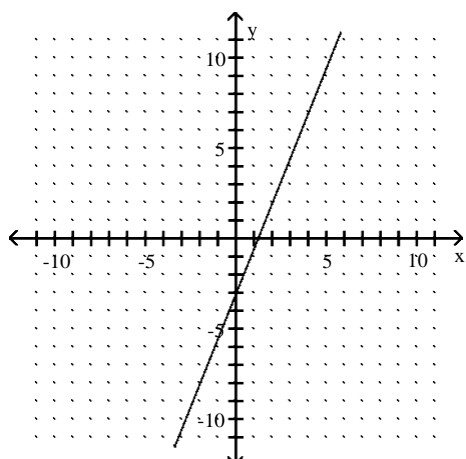

Answer: C

Graph the line described.

237) through $(0, 4)$; $m = \frac{1}{6}$

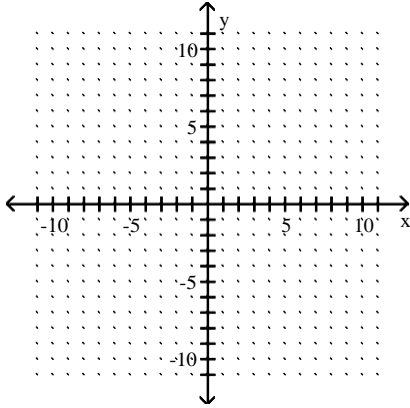

A)

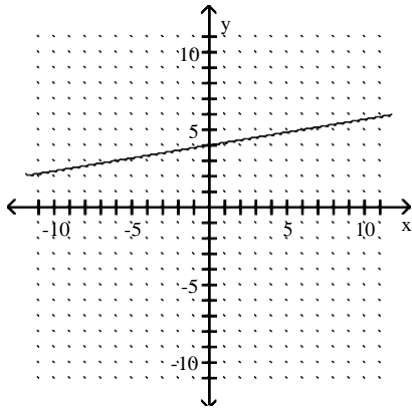

B)

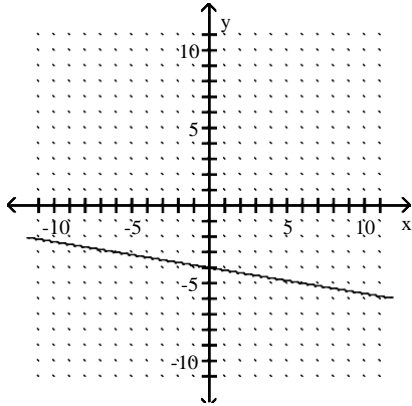

C)

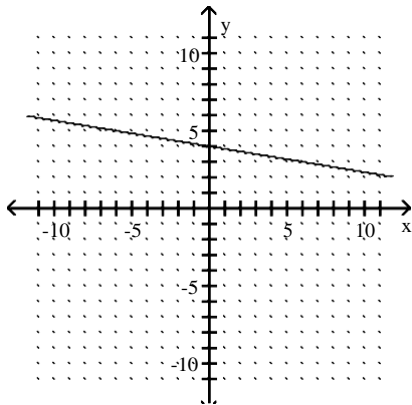

D)

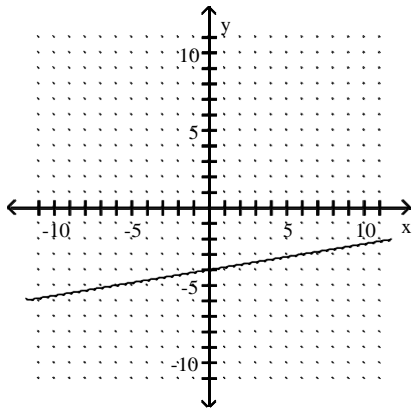

Answer: A

238) through $(-3, -9)$; $m = 4$

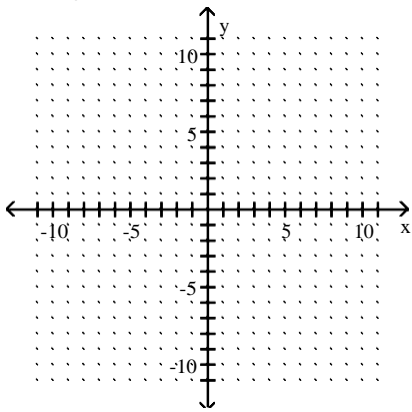

A)

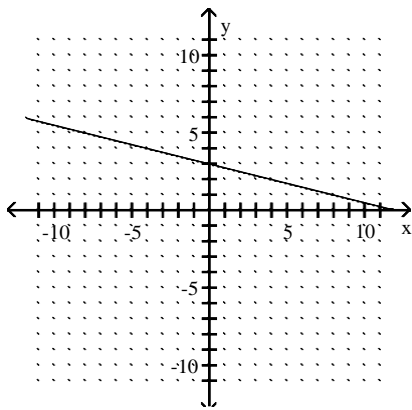

B)

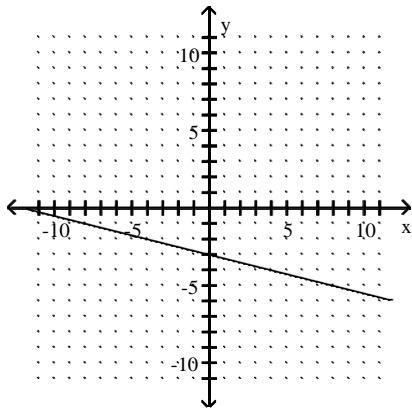

C)

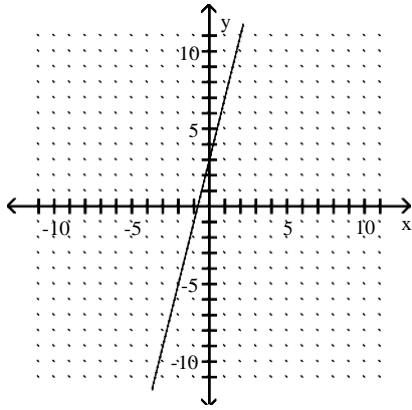

D)

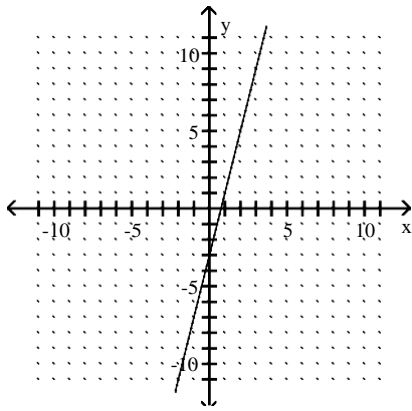

Answer: C

239) through $(0, 5)$; $m = -2$

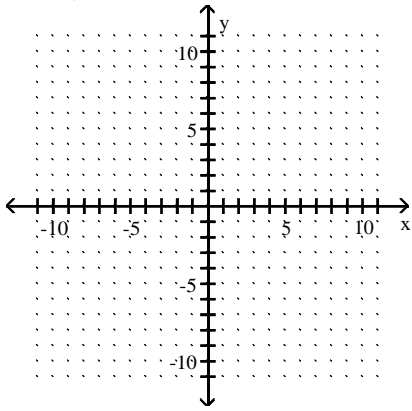

A)

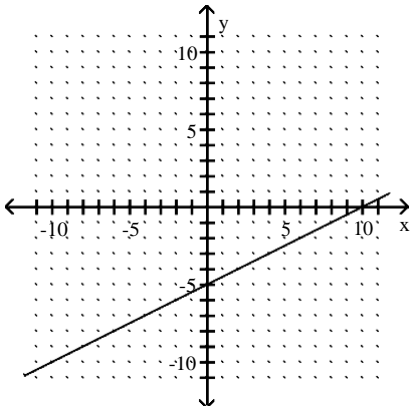

B)

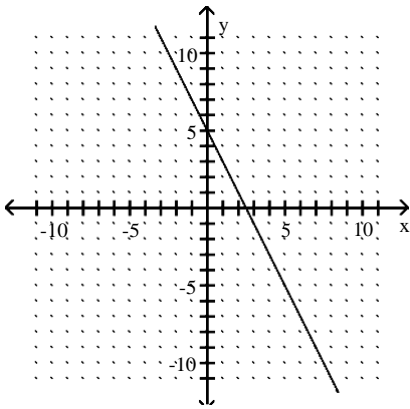

C)

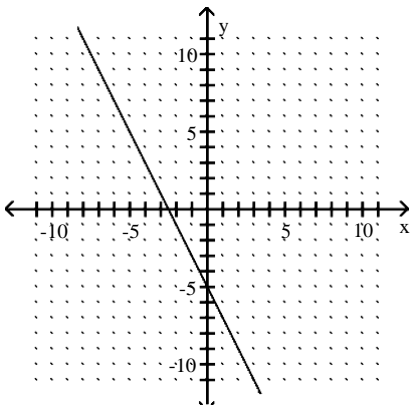

D)

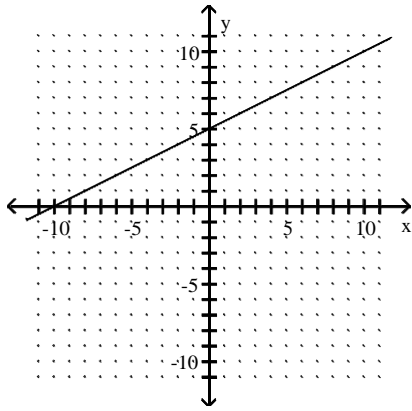

Answer: B

240) through $(0, 4)$; $m = -\frac{1}{3}$

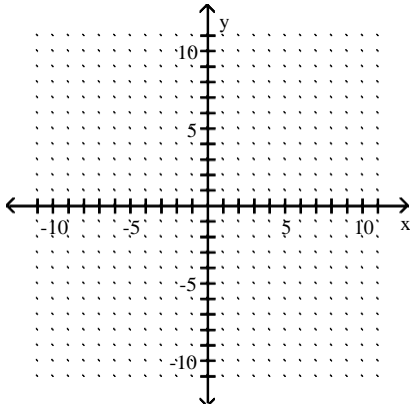

A)

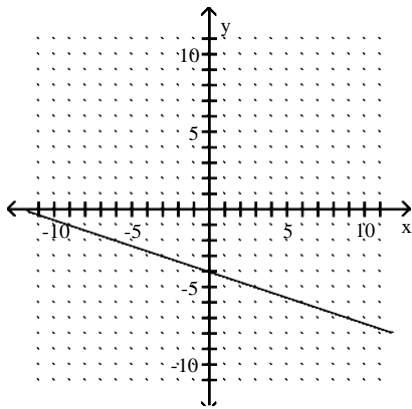

B)

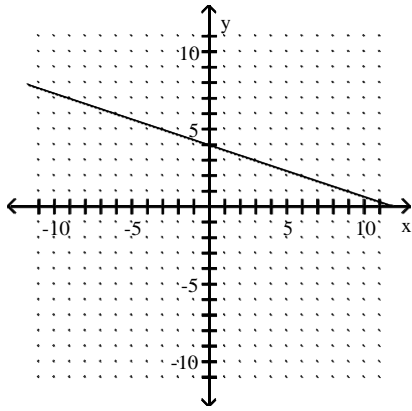

C)

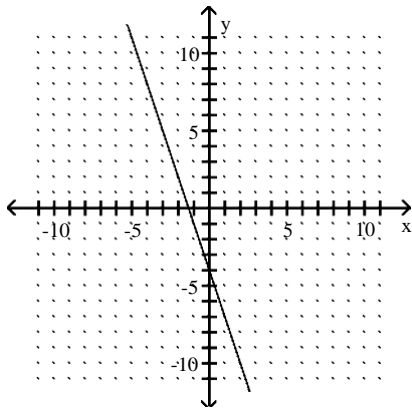

D)

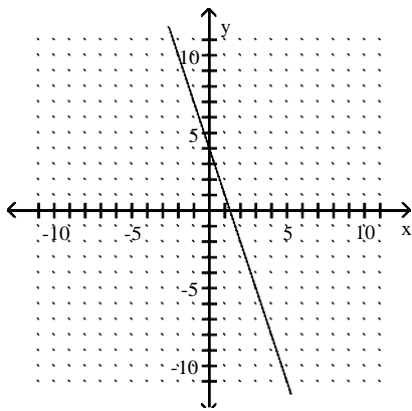

Answer: B

241) through $(6, 0)$; $m = -\frac{1}{2}$

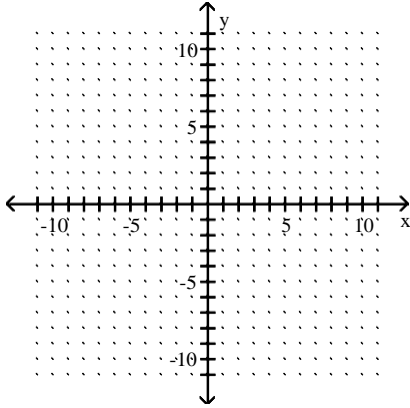

A)

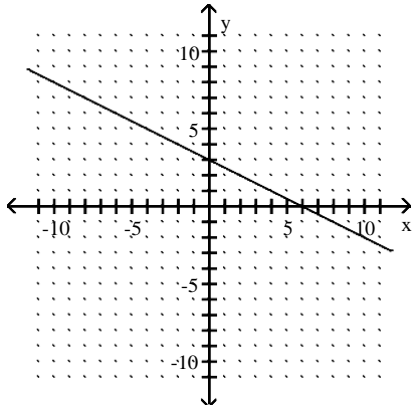

B)

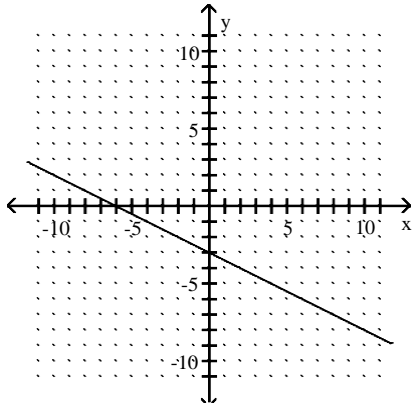

C)

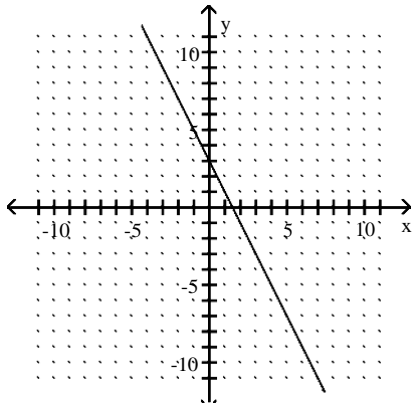

D)

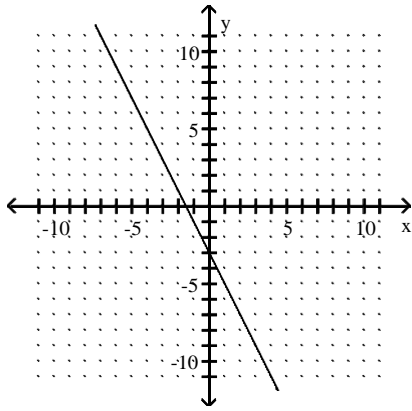

Answer: A

242) through $(2, 8)$; $m = 0$

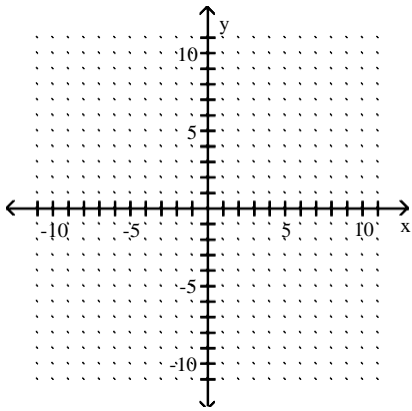

A)

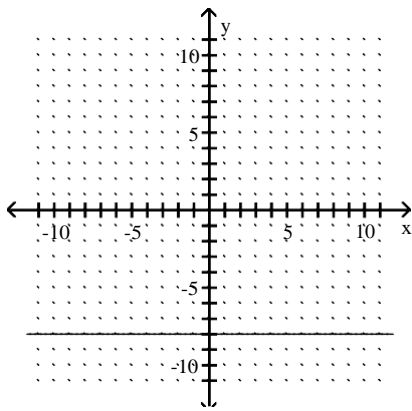

B)

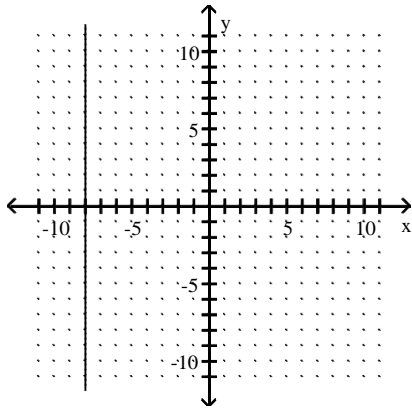

C)

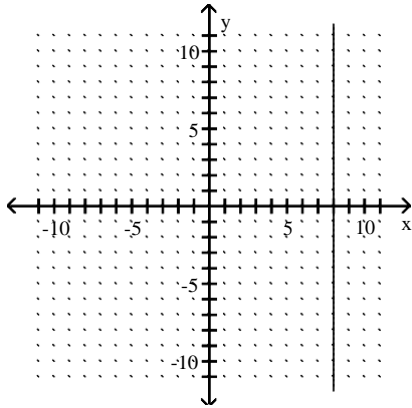

D)

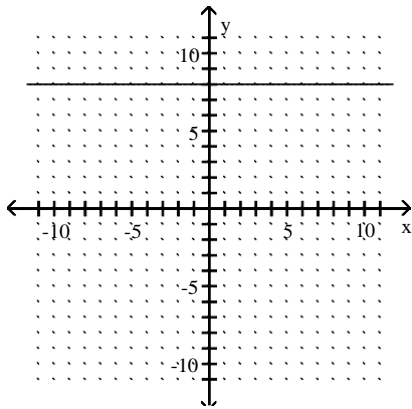

Answer: D

243) through $(5, -2)$; $m = 0$

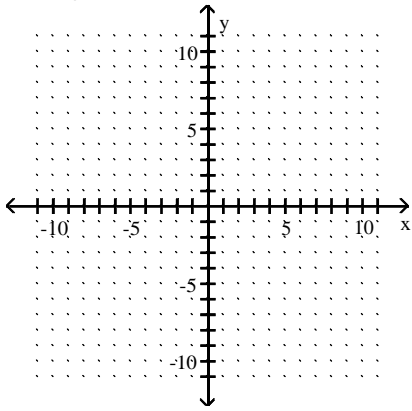

A)

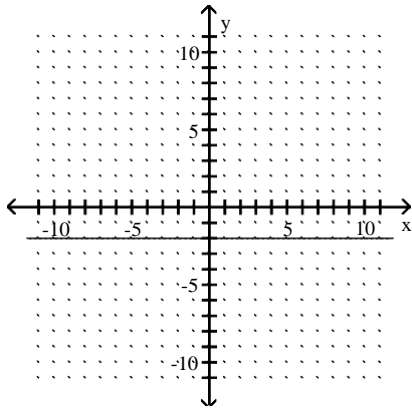

B)

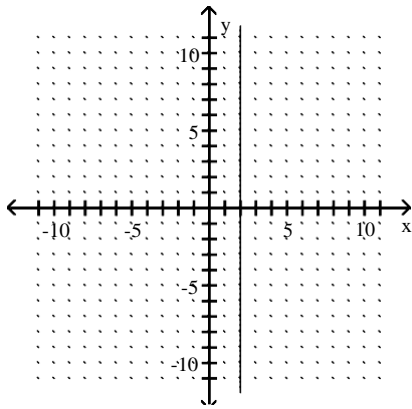

C)

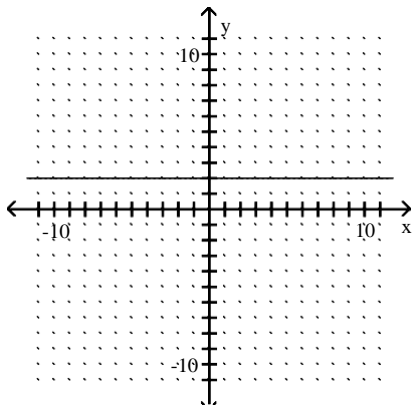

D)

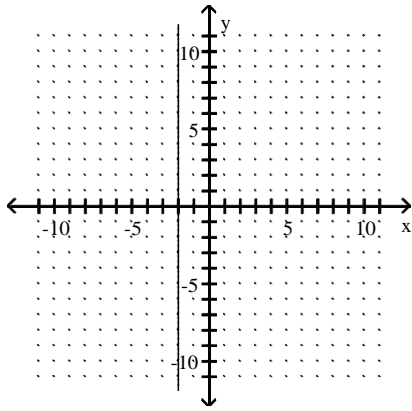

Answer: A

244) through (3, 9); undefined slope

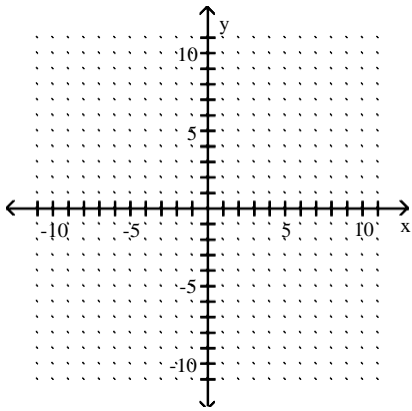

A)

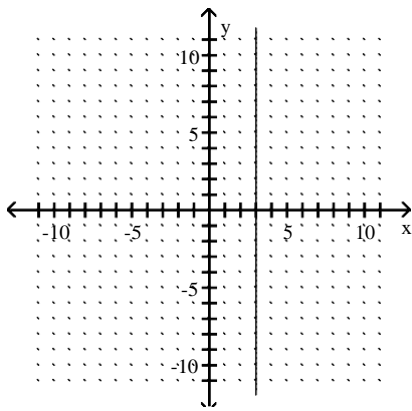

B)

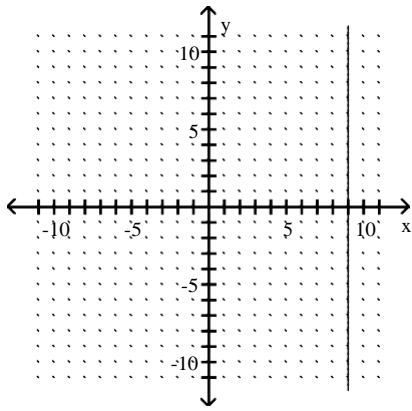

C)

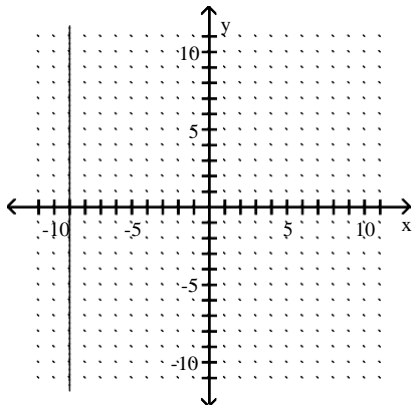

D)

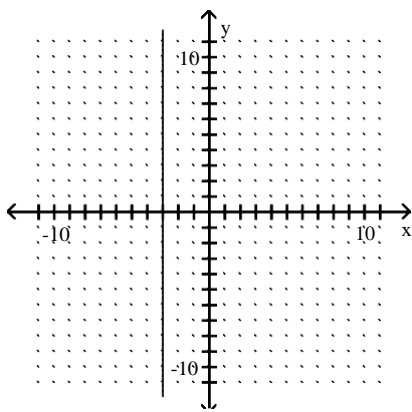

Answer: A

Choose the value which could represent the slope of the line. Assume that the scale on the x-axis is the same as the scale on the y-axis.

245)

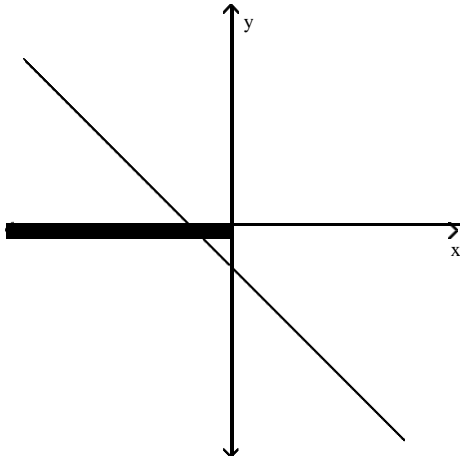

- A) -1
- B) 2
- C) 1
- D) -2

Answer: A

246)

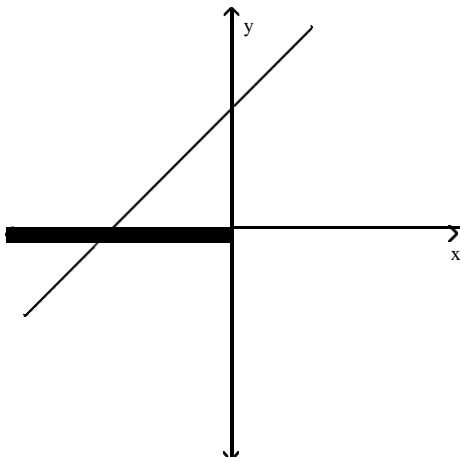

- A) 1
- B) 7
- C) -7
- D) -1

Answer: A

247)

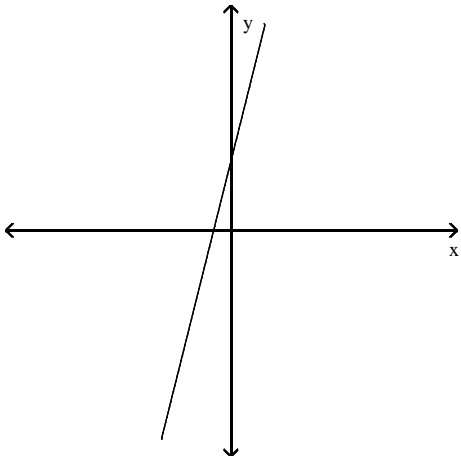

A) 4

B) $-\frac{1}{4}$

C) $\frac{1}{4}$

D) - 4

Answer: A

248)

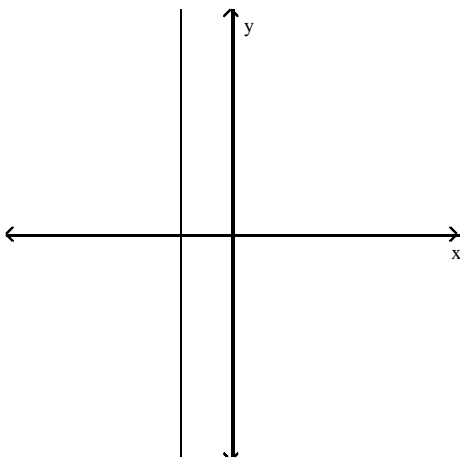

A) $\frac{3}{2}$

B) 0

C) undefined

D) -2

Answer: C

249)

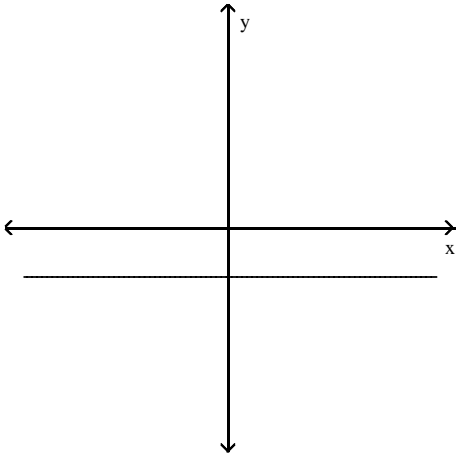

- A) 2
- B) undefined
- C) 0
- D) -2

Answer: C

Find the average rate of change illustrated in the graph.

250)

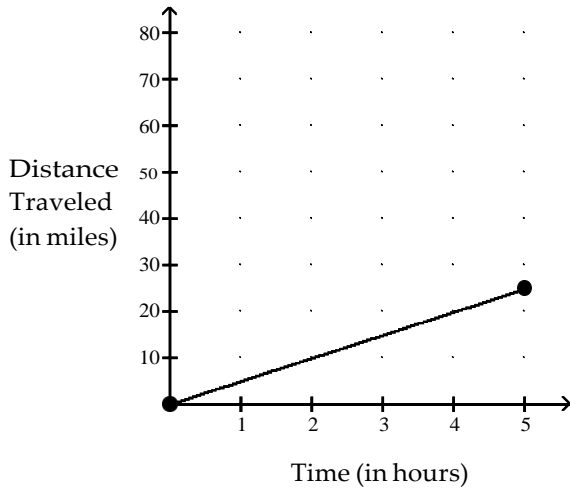

- A) 5 miles per hour
- B) 2.5 miles per hour
- C) 0.2 miles per hour
- D) 25 miles per hour

Answer: A

251)

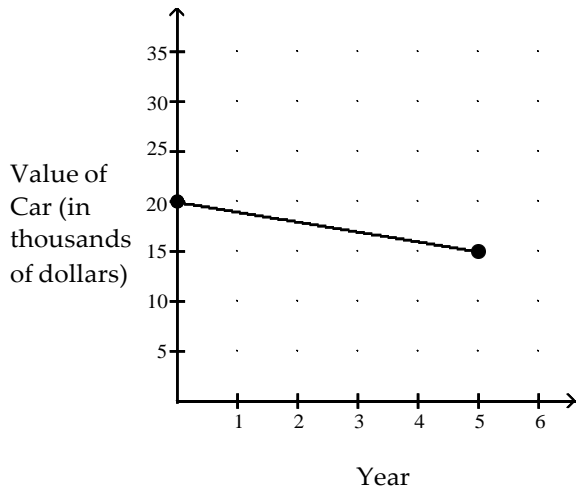

- A) -\$1000.00 per year
- B) \$2000.00 per year
- C) -\$2000.00 per year
- D) \$1000.00 per year

Answer: A

252)

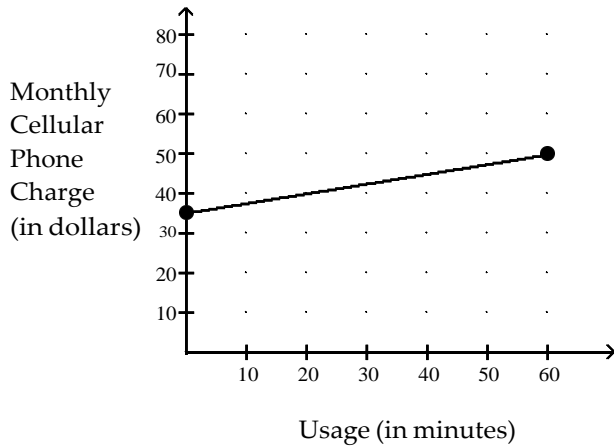

- A) \$0.50 per minute
- B) \$4.00 per minute
- C) \$0.25 per minute
- D) \$2.00 per minute

Answer: C

253)

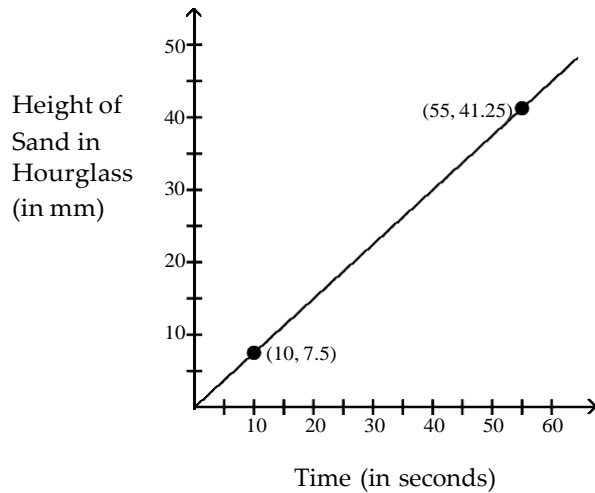

- A) 0.85 mm per second
- B) 1.3 mm per second
- C) 1 mm per second
- D) 0.75 mm per second

Answer: D

Solve the problem.

254) From April through December, the stock price of QRS Company had a roller coaster ride. The chart below indicates the price of the stock at the beginning of each month during that period. Find the average rate of change in price per month between June and September. Round to the nearest cent.

Month	Price
April (x = 1)	115
May	107
June	89
July	99
August	94
September	111
October	92
November	86
December	65

- A) -\$11.00 per month
- B) \$7.33 per month
- C) \$11.00 per month
- D) -\$7.33 per month

Answer: B

- 255) Along with incomes, people's charitable contributions have steadily increased over the past few years. The table below shows the average deduction for charitable contributions reported on individual income tax returns over 6 years. Find the average rate of change per year between year 3 and year 5.

Year	Charitable Contributions
1	\$1720
2	\$2360
3	\$2460
4	\$2820
5	\$3040
6	\$3190

- A) \$340 per year
- B) \$580 per year
- C) \$365 per year
- D) \$290 per year

Answer: D

- 256) The rate of return of certain investments increases as the risk factor of the investment increases. An investment with a risk factor of 2 has a rate of return of 5.0%. An investment with a risk factor of 19 has a rate of return of 12.0%. What is the average rate of change in return per unit of risk? Round to two decimal places.
- A) 0.71% per unit risk
 - B) 1.40% per unit risk
 - C) 2.43% per unit risk
 - D) 0.41% per unit risk

Answer: D

- 257) A deep sea diving bell is being lowered at a constant rate. After 10 minutes, the bell is at a depth of 600 ft. After 50 minutes the bell is at a depth of 1900 ft. What is the average rate of change of depth? Round to one decimal place.
- A) 26.0 ft per minute
 - B) 32.5 ft per minute
 - C) 0.03 ft per minute
 - D) 38.0 ft per minute

Answer: B

- 258) The linear function $f(x) = 2.9x + 35$ models the percentage of people, $f(x)$, who graduated from college x years after 1998. Find and interpret the slope.
- A) $m = 2.9$; the percentage of people graduating from college has decreased at a rate of 2.9% per year since 1998.
 - B) $m = 2.9$; the percentage of people graduating from college has increased at a rate of 2.9% per year since 1998.
 - C) $m = 35$; the percentage of people graduating from college has increased at a rate of 35% per year since 1998.
 - D) $m = -2.9$; the percentage of people graduating from college has decreased at a rate of 2.9% per year since 1998.

Answer: B

- 259) A school has just purchased new computer equipment for \$15,000.00. The graph shows the depreciation of the equipment over 5 years. The point (0, 15,000) represents the purchase price and the point (5, 0) represents when the equipment will be replaced. Find and interpret the average rate of change in cost per year.

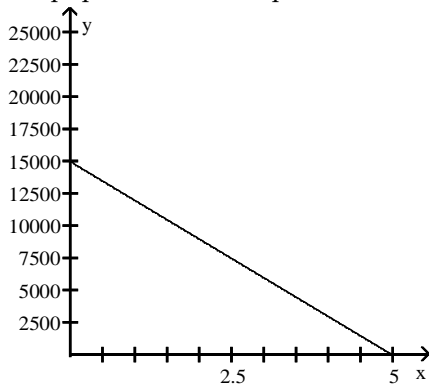

- A) \$3000 per year; the value of the equipment increases by \$3000 per year during these years.
 B) -\$15,000 per year; the value of the equipment decreases by \$15,000 per year during these years.
 C) -\$3000 per year; the value of the equipment decreases by \$3000 per year during these years.
 D) -\$3000 per year; the value of the equipment decreases by \$3000 per year during these years.

Answer: D

- 260) An investment is worth \$3690 in year 0, the initial investment year. By year 4 its value has increased to \$5802. Let y be the value of the investment in the year x . Find and interpret the average rate of change in value per year.

- A) \$528 per year; the value of the investment increases by \$528 per year during these years.
 B) \$7914 per year; the value of the investment increases by \$7914 per year during these years.
 C) \$3690 per year; the value of the investment increases by \$3690 per year during these years.
 D) -\$528 per year; the value of the investment decreases by \$528 per year during these years.

Answer: A

- 261) A faucet is used to add water to a large bottle that already contained some water. After it has been filling for 5 seconds, the gauge on the bottle indicates that it contains 15 ounces of water. After it has been filling for 12 seconds, the gauge indicates the bottle contains 29 ounces of water. Find and interpret the average rate of change in the volume of water per second.

- A) 2 ounces per second; the average rate of change in the volume of water is 2 ounces per second.
 B) 17 ounces per second; the average rate of change in the volume of water is 17 ounces per second.
 C) 5 ounces per second; the average rate of change in the volume of water is 5 ounces per second.
 D) $\frac{1}{2}$ ounce per second; the average rate of change in the volume of water is $\frac{1}{2}$ ounce per second.

Answer: A

- 262) Re grind, Inc. regrinds used typewriter platens. The variable cost to regrind each platen is \$1.90. The total cost to regrind 100 platens is \$400. Find the linear cost function to regrind platens. If reground platens sell for \$8.00 each, how many must be reground and sold to break even?

- A) $C(x) = 1.90x + 400$; 41 platens
 B) $C(x) = 1.90x + 400$; 66 platens
 C) $C(x) = 1.90x + 210$; 35 platens
 D) $C(x) = 1.90x + 210$; 22 platens

Answer: C

263) Northwest Molded molds plastic handles which cost \$0.50 per handle to mold. The fixed cost to run the molding machine is \$4664 per week. If the company sells the handles for \$4.50 each, how many handles must be molded and sold weekly to break even?

- A) 932 handles
- B) 777 handles
- C) 9328 handles
- D) 1166 handles

Answer: D

264) A lumber yard has fixed costs of \$2758.80 per day and variable costs of \$0.74 per board-foot produced. Lumber sells for \$1.84 per board-foot. How many board-feet must be produced and sold daily to break even?

- A) 1672 board-feet
- B) 2508 board-feet
- C) 1069 board-feet
- D) 3728 board-feet

Answer: B

Match the equation with the correct graph.

265) $7x + 6y = -18$

A)

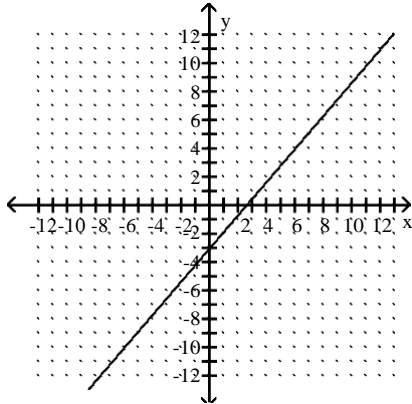

B)

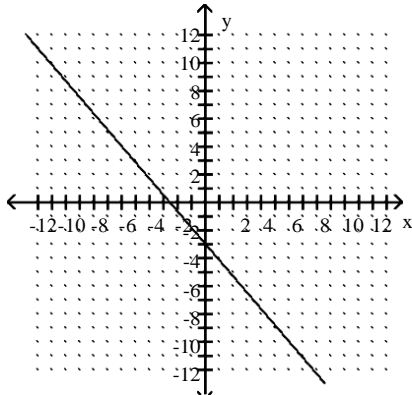

C)

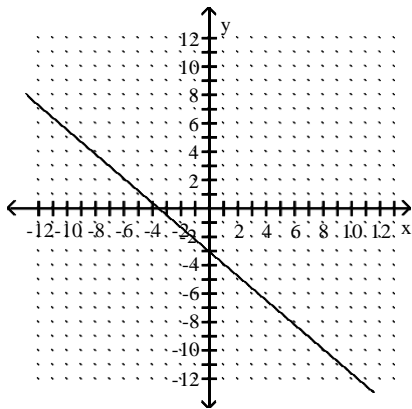

D)

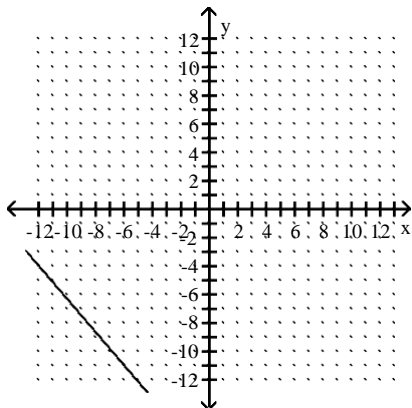

Answer: B

266) $6x - 7y = 14$

A)

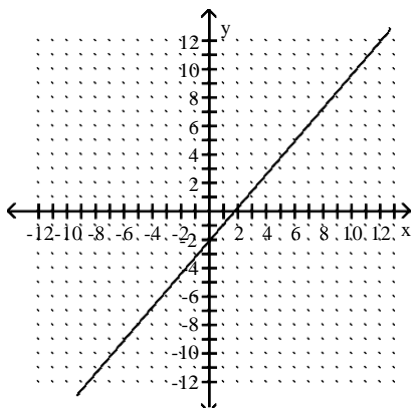

B)

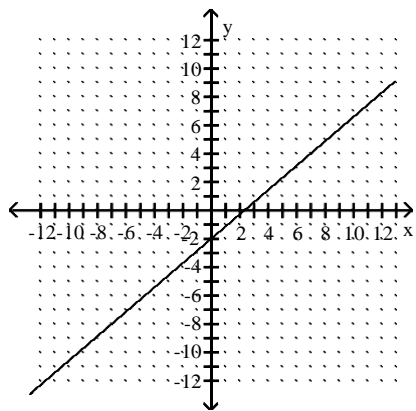

C)

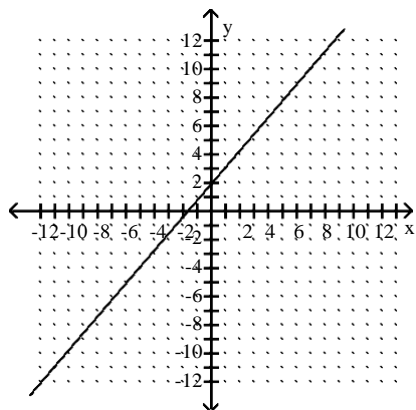

D)

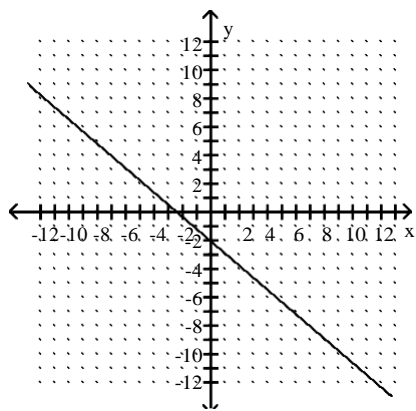

Answer: B

$$267) y = \frac{1}{5}x + 1$$

A)

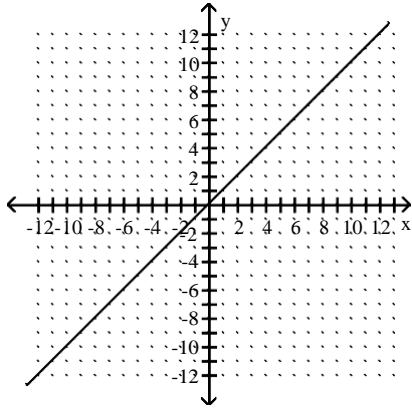

B)

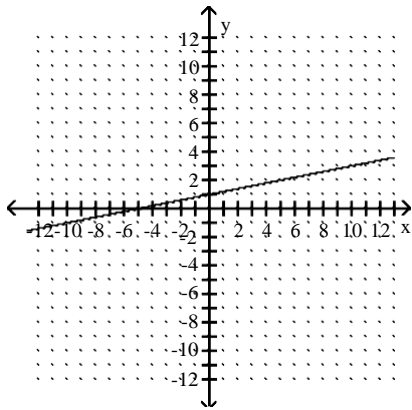

C)

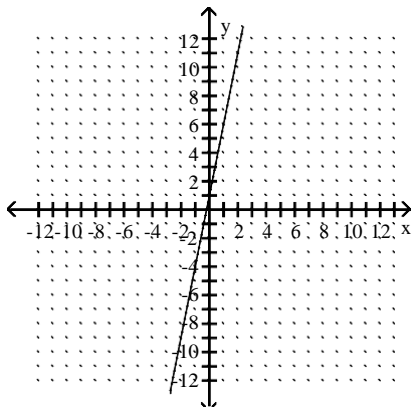

D)

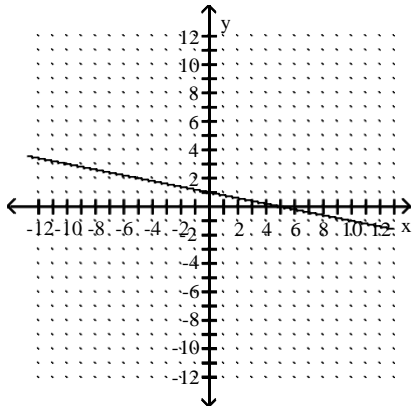

Answer: B

268) $y = -\frac{1}{3}x + 1$

A)

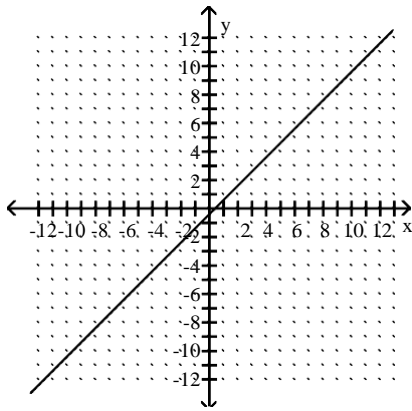

B)

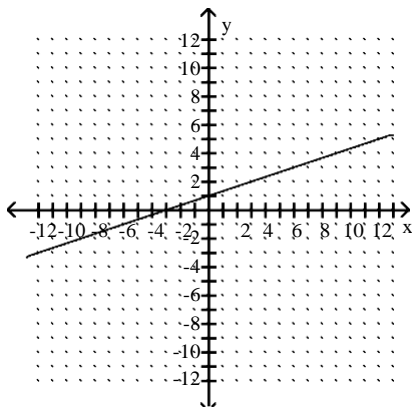

C)

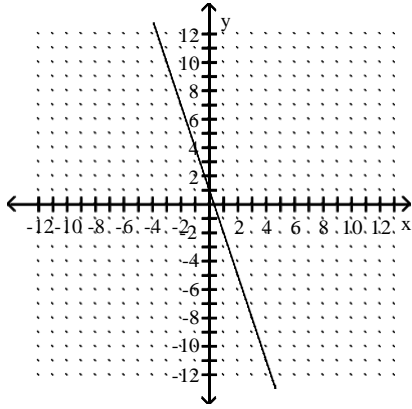

D)

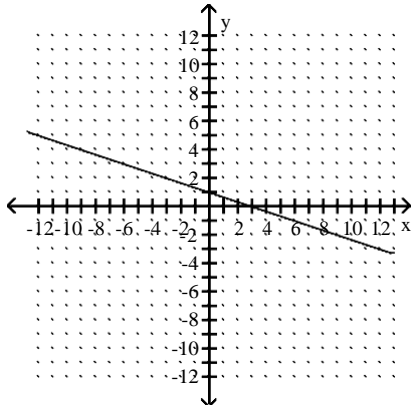

Answer: D

$$269) y - 4 = \frac{3}{8}(x + 2)$$

A)

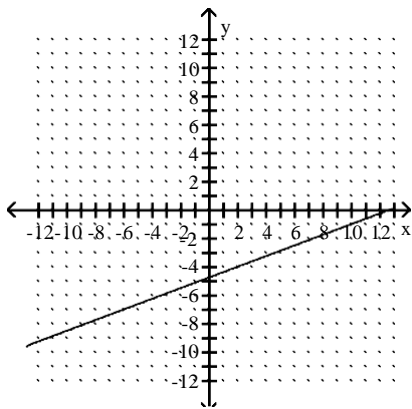

B)

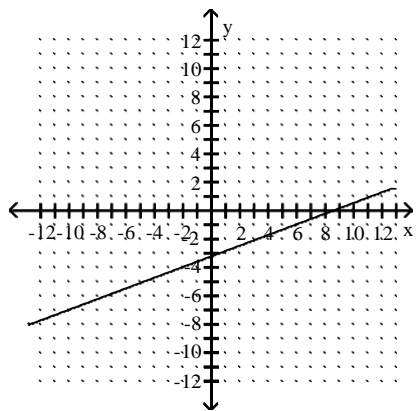

C)

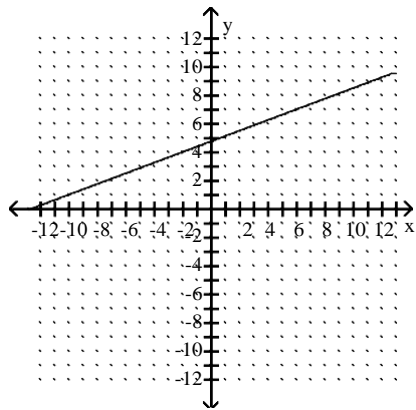

D)

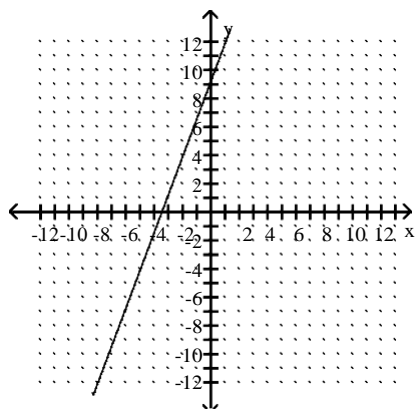

Answer: C

$$270) y + 5 = \frac{6}{5}(x + 1)$$

A)

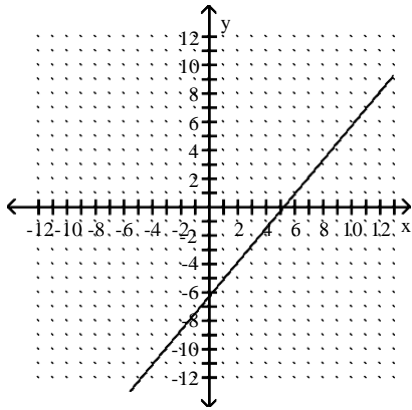

B)

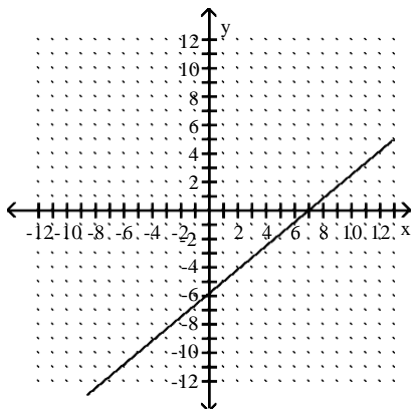

C)

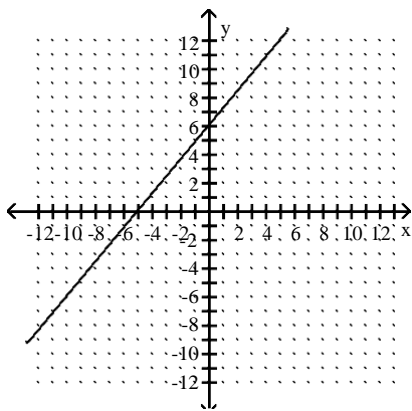

D)

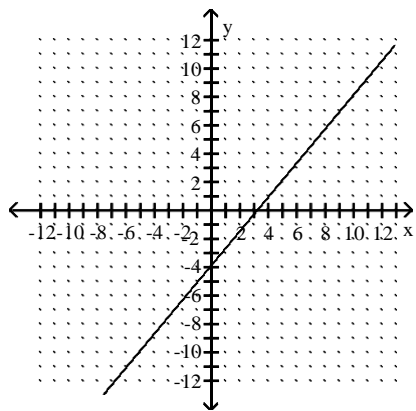

Answer: D

271) $y = 1$

A)

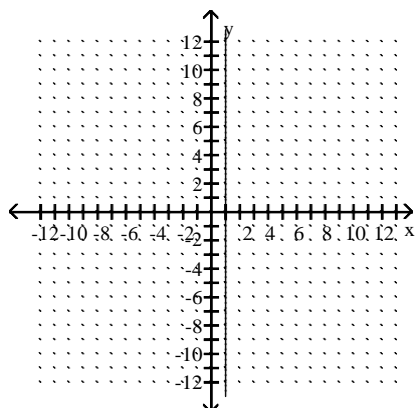

B)

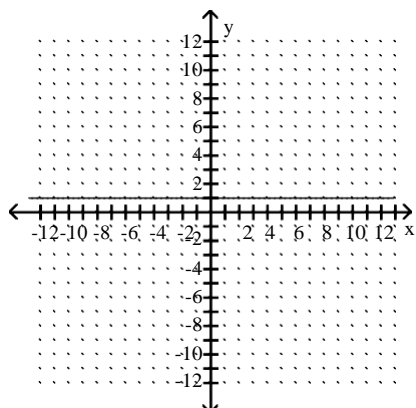

C)

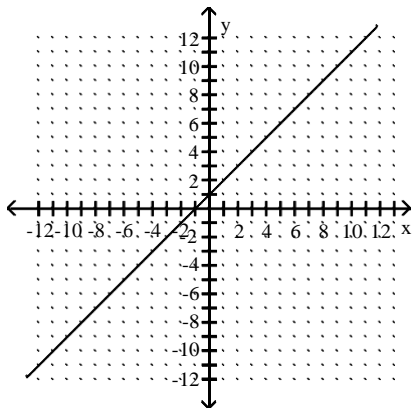

D)

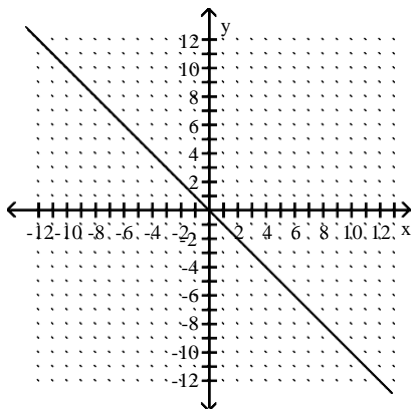

Answer: B

272) $x = 2$

A)

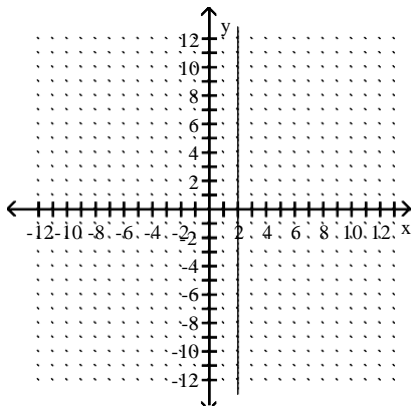

B)

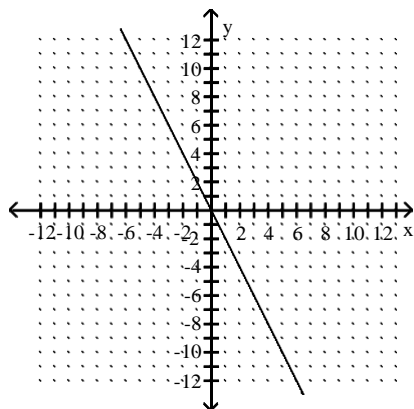

C)

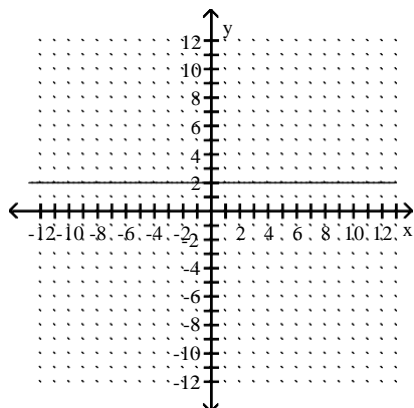

D)

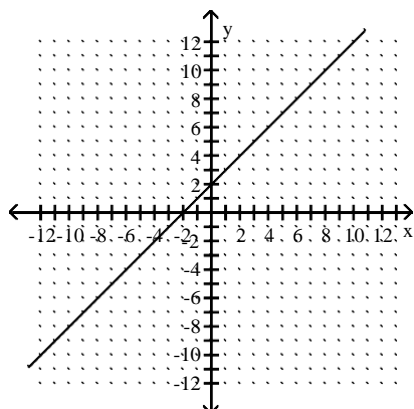

Answer: A

Write an equation for the line described. Give your answer in standard form.

273) through $(0, 2)$, $m = \frac{5}{6}$

- A) $5x - 6y = -12$
- B) $6x - 5y = -12$
- C) $5x + 6y = -12$
- D) $5x - 6y = 12$

Answer: A

274) through (4, 5), undefined slope

- A) $y = 5$
- B) $x = 4$
- C) $x = 5$
- D) $y = 4$

Answer: B

275) x-intercept 3, y-intercept 2

- A) $2x - 3y = 6$
- B) $-2x + 3y = 6$
- C) $2x + 3y = -6$
- D) $2x + 3y = 6$

Answer: D

Write an equation for the line described. Give your answer in slope-intercept form.

276) $m = 4$, through (2, -4)

- A) $y = 4x + 11$
- B) $y = 4x - 12$
- C) $y = 5x + 13$
- D) $y = 4x - 10$

Answer: B

277) $m = -9$, through (-9, 2)

- A) $y = -9x - 79$
- B) $9x + y = 79$
- C) $y = -9x + 86$
- D) $y = 9x - 77$

Answer: A

278) $m = \frac{2}{3}$, through (-9, 7)

- A) $y = -\frac{2}{3}x - 13$
- B) $y = \frac{2}{3}x - 13$
- C) $y = \frac{3}{2}x + \frac{39}{2}$
- D) $y = \frac{2}{3}x + 13$

Answer: D

279) horizontal, through (4, -5)

- A) $x = -5$
- B) $y = 4$
- C) $x = 4$
- D) $y = -5$

Answer: D

280) vertical, through $(-4, 4)$

- A) $x = 4$
- B) $y = 4$
- C) $x = -4$
- D) $y = -4$

Answer: C

281) through $(4, 1)$, $m = 0$

- A) $y = 4$
- B) $y = 1$
- C) $x = 1$
- D) $x = 4$

Answer: B

282) through $(2, 8)$ and $(0, -7)$

- A) $y = -\frac{15}{2}x - 7$
- B) $y = -\frac{6}{7}x - 7$
- C) $y = \frac{6}{7}x - 7$
- D) $y = \frac{15}{2}x - 7$

Answer: D

283) $m = -3$, $b = 9$

- A) $y = 9x - 3$
- B) $-3x + 9y = 0$
- C) $y = -3x + 9$
- D) $y = -3x + 9$

Answer: C

284) $m = \frac{3}{2}$, $b = -3$

- A) $y = -3x + \frac{3}{2}$
- B) $y = \frac{3}{2}x - 3$
- C) $\frac{3}{2}x - 3y = 0$
- D) $y = \frac{3}{2}x + 3$

Answer: B

285) slope 0, y-intercept $\frac{11}{3}$

A) $x = \frac{11}{3}$

B) $y = \frac{11}{3}$

C) $y = -\frac{11}{3}x$

D) $y = \frac{11}{3}x$

Answer: B

Find the slope and the y-intercept of the line.

286) $9x + 7y = 71$

A) slope: $\frac{9}{7}$; y-intercept: $\frac{71}{7}$

B) slope: $-\frac{7}{9}$; y-intercept: $-\frac{7}{71}$

C) slope: $-\frac{9}{7}$; y-intercept: $\frac{71}{7}$

D) slope: $\frac{7}{9}$; y-intercept: $\frac{7}{71}$

Answer: C

287) $6x - 8y = 8$

A) slope: $-\frac{3}{4}$; y-intercept: 1

B) slope: $\frac{3}{4}$; y-intercept: -1

C) slope: $\frac{4}{3}$; y-intercept: 1

D) slope: $-\frac{4}{3}$; y-intercept: -1

Answer: B

288) $y = -9x + 2$

A) slope: 2; y-intercept: 9

B) slope: 9; y-intercept: 2

C) slope: 2; y-intercept: -9

D) slope: -9; y-intercept: 2

Answer: D

289) $-4y = 3x$

- A) slope: 0; y-intercept: $-\frac{4}{3}$
- B) slope: 0; y-intercept: $-\frac{3}{4}$
- C) slope: $-\frac{4}{3}$; y-intercept: 0
- D) slope: $-\frac{3}{4}$; y-intercept: 0

Answer: D

290) $x + 2y = -3$

- A) slope: $-\frac{3}{2}$; y-intercept: $-\frac{1}{2}$
- B) slope: $\frac{1}{2}$; y-intercept: $-\frac{3}{2}$
- C) slope: -2; y-intercept: -3
- D) slope: $-\frac{1}{2}$; y-intercept: $-\frac{3}{2}$

Answer: D

291) $8x - y = -2$

- A) slope: $\frac{1}{8}$; y-intercept: -2
- B) slope: 2; y-intercept: 8
- C) slope: 8; y-intercept: -2
- D) slope: 8; y-intercept: 2

Answer: D

292) $y - 4x + 3 = 0$

- A) slope: 4; y-intercept: 3
- B) slope: 4; y-intercept: -3
- C) slope: 3; y-intercept: -4
- D) slope: -3; y-intercept: 4

Answer: B

The graph of a linear function f is shown. Identify the slope, y -intercept, and x -intercept.

293)

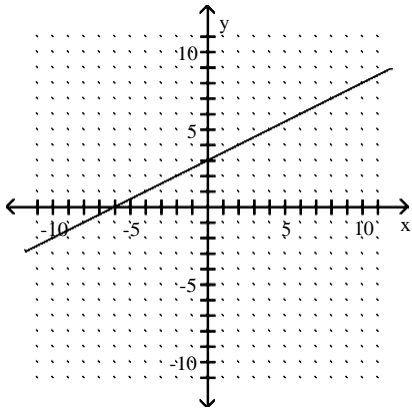

- A) 2; 3, -6
- B) $\frac{1}{2}$; 3, -6
- C) $\frac{1}{2}$; -6, 3
- D) 2; -6, 3

Answer: B

294)

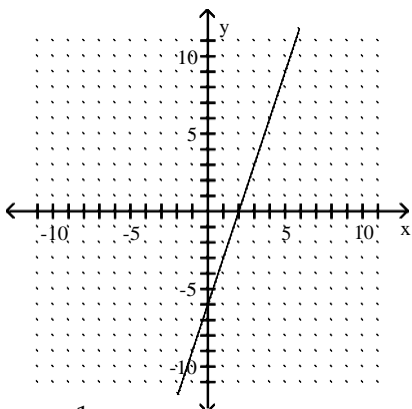

- A) $\frac{1}{3}$; 2, -6
- B) 3; -6, 2
- C) 3; 2, -6
- D) $\frac{1}{3}$; -6, 2

Answer: B

295)

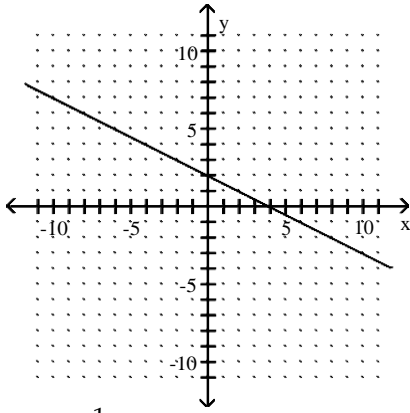

A) $-\frac{1}{2}; 2, 4$

B) $\frac{1}{2}; 2, 4$

C) $-\frac{1}{2}; 4, 2$

D) $-2; 2, 4$

Answer: A

The graph of a linear function f is shown. Write the equation that defines f . Write the equation in slope-intercept form.

296)

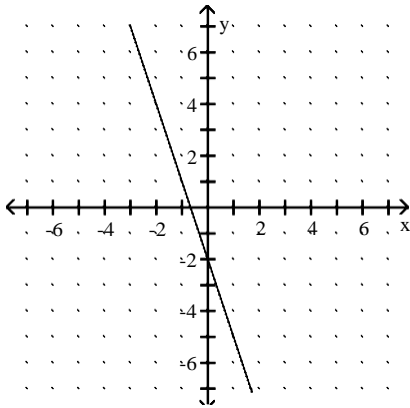

A) $y = -3x + 2$

B) $y = 3x + 2$

C) $y = 3x - 2$

D) $y = -3x - 2$

Answer: D

297)

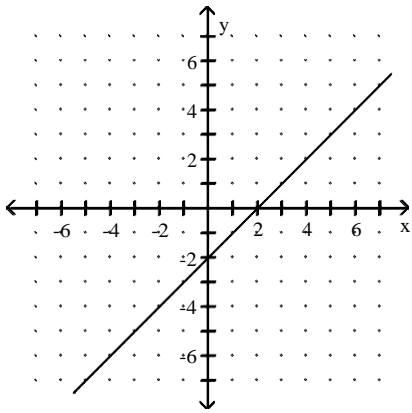

- A) $y = -x + 2$
- B) $y = -x - 2$
- C) $y = x + 2$
- D) $y = x - 2$

Answer: D

298)

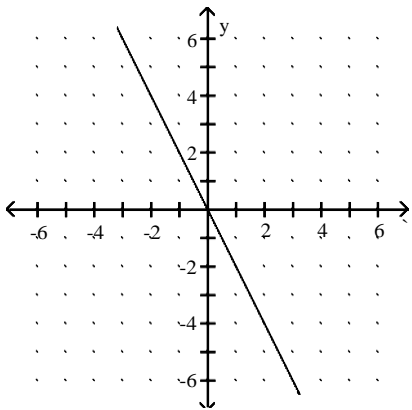

- A) $y = \frac{x}{2}$
- B) $y = 2x$
- C) $y = -2x$
- D) $y = -\frac{x}{2}$

Answer: C

299)

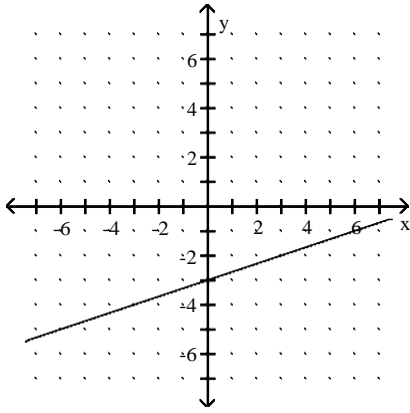

A) $y = \frac{1}{3}x + 3$

B) $y = 3x - 3$

C) $y = 3x + 3$

D) $y = \frac{1}{3}x - 3$

Answer: D

300)

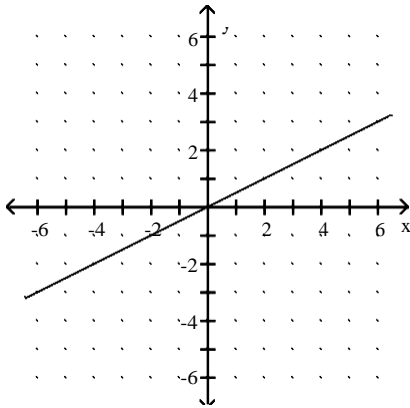

A) $y = 2x$

B) $y = -\frac{1}{2}x$

C) $y = -2x$

D) $y = \frac{1}{2}x$

Answer: D

301)

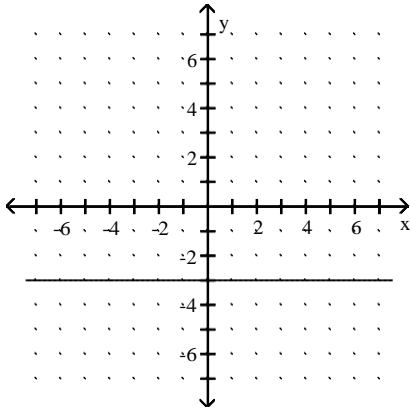

- A) $x = 3$
- B) $y = 3$
- C) $x = -3$
- D) $y = -3$

Answer: D

Write an equation for the line described. Write the equation in the form specified.

302) parallel to $y = -5$, through $(8, 9)$

- A) $y = -5$
- B) $y = -9$
- C) $y = 9$
- D) $y = 8$

Answer: C

303) parallel to $x = 6$, through $(7, 2)$

- A) $y = 2$
- B) $x = 7$
- C) $y = 6$
- D) $x = 2$

Answer: B

304) perpendicular to $y = 8$, through $(1, 4)$

- A) $x = 1$
- B) $y = 1$
- C) $y = 4$
- D) $x = 4$

Answer: A

305) perpendicular to $x = -3$, through $(2, 4)$

- A) $x = 2$
- B) $y = 4$
- C) $x = 4$
- D) $y = 2$

Answer: B

306) parallel to $y + 8x = 4$, through $(3, 4)$; slope-intercept form

A) $y = -8x - 28$

B) $y = -\frac{1}{8}x - \frac{7}{2}$

C) $y = -8x + 28$

D) $y = 8x - 28$

Answer: C

307) perpendicular to $-5x + y = 5$, through $(5, 5)$; slope-intercept form

A) $y = -\frac{1}{5}x + 6$

B) $y = -\frac{1}{5}x - 6$

C) $y = -5x - 30$

D) $y = \frac{1}{5}x - 6$

Answer: A

308) parallel to $6x - 5y = 17$, through $(2, -3)$; slope-intercept form

A) $y = \frac{2}{5}x - \frac{17}{5}$

B) $y = \frac{6}{5}x - \frac{27}{5}$

C) $y = \frac{5}{6}x - \frac{1}{2}$

D) $y = -\frac{6}{5}x + \frac{27}{5}$

Answer: B

309) parallel to $9x + 7y = -45$; through $(2, -5)$; standard form

A) $9x - 7y = -17$

B) $7x + 9y = -5$

C) $2x + 7y = -45$

D) $9x + 7y = -17$

Answer: D

310) perpendicular to $-8x + 9y = 82$, through $(-8, -2)$; slope-intercept form

A) $y = \frac{9}{8}x - 11$

B) $y = -\frac{9}{8}x - 11$

C) $y = -\frac{8}{9}x - \frac{82}{9}$

D) $y = -\frac{8}{9}x - \frac{8}{9}$

Answer: B

311) perpendicular to $7x - 8y = 71$, through $(9, 1)$; standard form

- A) $9x + 8y = 71$
- B) $8x - 7y = 79$
- C) $7x + 8 = 7$
- D) $8x + 7y = 79$

Answer: D

Solve the problem. Write all linear equations in slope-intercept form.

312) A house was purchased for \$66,000. After 5 years the value of the house was \$111,000. Find a linear equation that models the value of the house after x years.

- A) $y = 9000x$
- B) $y = 5x + 66,000$
- C) $y = 9000x + 66,000$
- D) $y = 111,000$

Answer: C

313) A company can make 12 airplane engines for \$74,000, while 19 airplane engines cost \$77,500. Find a linear equation that models the cost to produce x airplane engines.

- A) $y = x + 3500$
- B) $y = 500x + 68,000$
- C) $y = 500x - 68,000$
- D) $y = 7x + 3500$

Answer: B

314) In a lab experiment 12 grams of acid were produced in 27 minutes and 20 grams in 50 minutes. Find a linear equation that models the number of grams produced in x minutes.

- A) $y = -\frac{8}{23}x + \frac{60}{23}$
- B) $y = \frac{23}{8}x + \frac{23}{60}$
- C) $y = -\frac{8}{23}x - \frac{60}{23}$
- D) $y = x + 15$

Answer: A

315) A biologist recorded 6 snakes on 28 acres in one area and 10 snakes on 35 acres in another area. Find a linear equation that models the number of snakes in x acres.

- A) $y = \frac{4}{7}x - 10$
- B) $y = x + 22$
- C) $y = \frac{7}{4}x - \frac{1}{10}$
- D) $y = \frac{4}{7}x + 10$

Answer: A

- 316) With 29.5% commitment, a company can clean up 45% of an energy leak. With 31.5% commitment, it can clean up 61% of an energy leak. Find a linear equation that models the percent cleanup for x percent commitment.
- A) $y = 8x + 191$
 - B) $y = 8x - 191$
 - C) $y = 2x + 16$
 - D) $y = x + 16$

Answer: B

- 317) Suppose that a sales person observes that if an item is priced at \$9 per item then 6 items are sold. If 4 items are sold for \$11 per item then find a linear equation to model the number y of items sold for x dollars per item. Find the slope-intercept form of the equation of the line.
- A) $y = -x + 15$
 - B) $y = x - 3$
 - C) $y = -x - 3$
 - D) $y = x + 15$

Answer: A

- 318) A driver wants to gauge the fuel efficiency of her vehicle at speeds of 30 mph and above. She notices that traveling at an average speed of 45 mph results in a rating of 40 mpg, whereas at an average speed of 50 mph, her car rates 30 mpg. Find a linear equation to model the gas mileage y for an average speed of x mph. Find the slope-intercept form of the equation of the line.

- A) $y = -2x + 130$
- B) $y = \frac{1}{2}x + 50$
- C) $y = -2x + 50$
- D) $y = \frac{1}{2}x + 130$

Answer: A

- 319) The table lists the average annual cost (in dollars) of room and board at public four-year colleges in the city of Bookhaven for selected years.

PUBLIC FOUR-YEAR COLLEGE ROOM AND BOARD

Year	Room and Board (in dollars)
1	1250
2	1505
3	1717.5
4	1967.5
5	2245
6	2505

Determine a linear function f defined by $f(x) = mx + b$ that models the data using (1, 1250) and (6, 2505).

- A) $f(x) = 999x + 251$
- B) $f(x) = 1250$
- C) $f(x) = 251x + 999$
- D) $f(x) = 2151 - 901x$

Answer: C

320) The amount of time t it takes a flame to go out in a closed container is a linear function of the volume of the container x . A flame in 748 mL container takes 14 seconds to go out and a flame in a 1100 mL container takes 22 seconds. Write a linear function that relates t to x .

A) $t = \frac{1}{44}x$

B) $t = \frac{1}{44}x - 3$

C) $t = 44x - 3$

D) $t = \frac{3}{154}x - \frac{4}{7}$

Answer: B

321) By reading a graph on defense spending in the country of Warpeas, you discover that in year 0 the country spent \$176 million on defense and in year 8 spent \$528 million. Write a linear function that relates y (in millions of dollars) to x .

A) $y = \frac{1}{4}x + 176$

B) $y = 44x + 176$

C) $y = 88x + 176$

D) $y = -44x - 176$

Answer: B

Use a graphing calculator to solve the linear equation.

322) $-8x + 7 + 6x = -2x + 12$

A) all real numbers

B) \emptyset

C) $\{5\}$

D) $\{-7\}$

Answer: B

323) $4(2z - 2) = 7(z + 2)$

A) $\{22\}$

B) $\{6\}$

C) $\{10\}$

D) $\{-6\}$

Answer: A

324) $10y = 5y + 7 + 4y$

A) $\{-7\}$

B) $\{-70\}$

C) $\{70\}$

D) $\{7\}$

Answer: D

325) $-2x + 7(-2x - 3) = -32 - 5x$

A) $\{-1\}$

B) $\{1\}$

C) $\{2\}$

D) $\{0\}$

Answer: B

326) $(-9x - 7) - 4 = -8(x + 8)$

- A) {19}
- B) {- 53}
- C) {- 61}
- D) {53}

Answer: D

327) Rewrite the equation so that one side is 0, then replace 0 with y. The graph of the equation for y is shown. Use the graph to determine the solution of the equation.

$3x + 1 + x = 2x - 3$

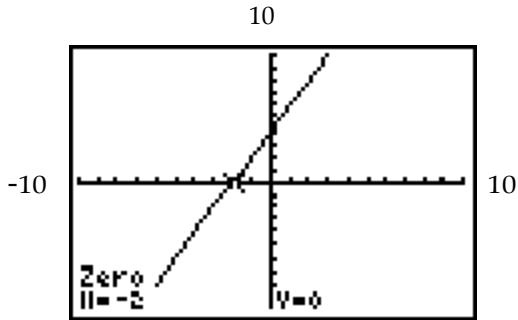

- A) $y = 2x + 4; -2$
- B) $y = 2x + 4; 0$
- C) $y = 4x + 2; 0$
- D) $y = 4x + 2; -2$

Answer: A

328) The graph of y_1 is shown in the standard viewing window. Which is the only choice that could possibly be the solution of the equation $y_1 = 0$?

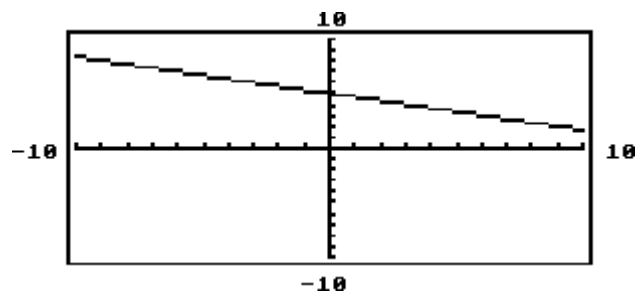

- 5, 5, $\frac{16}{3}$, 15
- A) $\frac{16}{3}$
- B) -5
- C) 5
- D) 15

Answer: D

329) The graph of y_1 is shown in the standard viewing window. Which is the only choice that could possibly be the solution of the equation $y_1 = 0$?

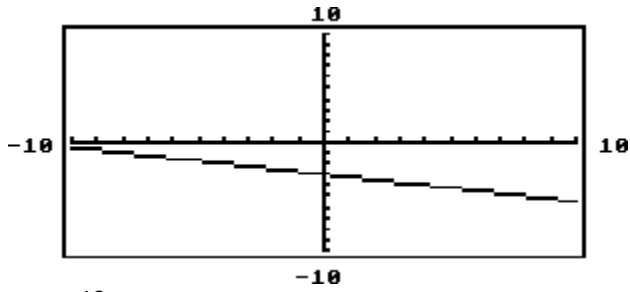

-12, $-\frac{13}{4}$, 3, 12

- A) 3
- B) 12
- C) $-\frac{13}{4}$
- D) -12

Answer: D

330) The graph of y_1 is shown in the standard viewing window. Which is the only choice that could possibly be the solution of the equation $y_1 = 0$?

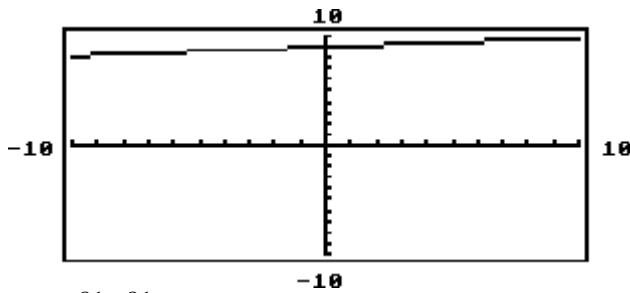

-90, $-\frac{91}{10}$, $\frac{91}{10}$, 85

- A) $-\frac{91}{10}$
- B) 85
- C) $\frac{91}{10}$
- D) -90

Answer: D

331) The graph of y_1 is shown in the standard viewing window. Which is the only choice that could possibly be the solution of the equation $y_1 = 0$?

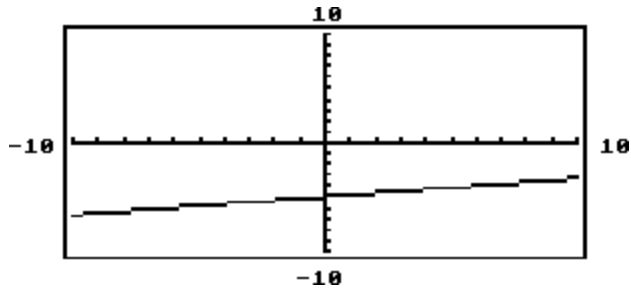

-30, $-\frac{31}{6}$, $\frac{31}{6}$, 30

- A) 30
- B) $-\frac{31}{6}$
- C) -30
- D) $\frac{31}{6}$

Answer: A

332) The graph of y_1 is shown in the standard viewing window. Which is the only choice that could possibly be the solution of the equation $y_1 = 0$?

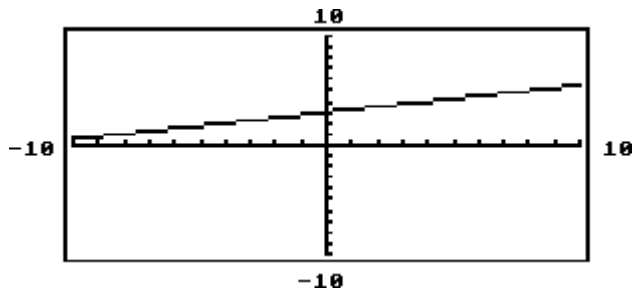

-12, -7, $-\frac{13}{4}$, 12

- A) -12
- B) $-\frac{13}{4}$
- C) -7
- D) 12

Answer: A

Determine whether the three points are collinear.

333) (2, -4), (3, -8), (1, 0)

- A) Yes
- B) No

Answer: A

334) $(9, 10), (7, 5), (14, 12)$

A) Yes

B) No

Answer: B

335) $(-5, -11), (3, 5), (9, 17)$

A) Yes

B) No

Answer: A

336) $(6, -2), (-1, 4), (1, 1)$

A) Yes

B) No

Answer: B

Refer to the following graphs to determine an appropriate response.

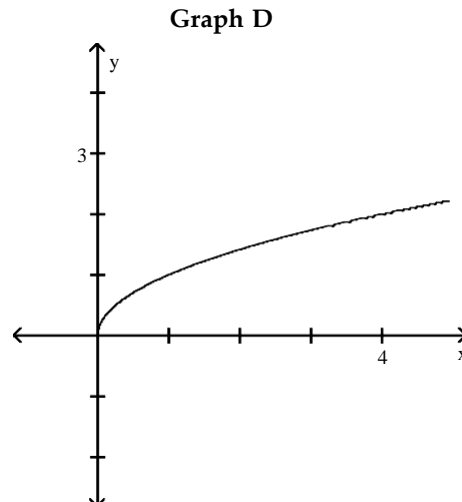
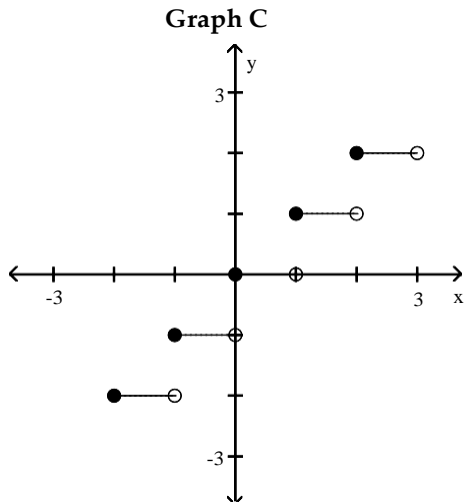
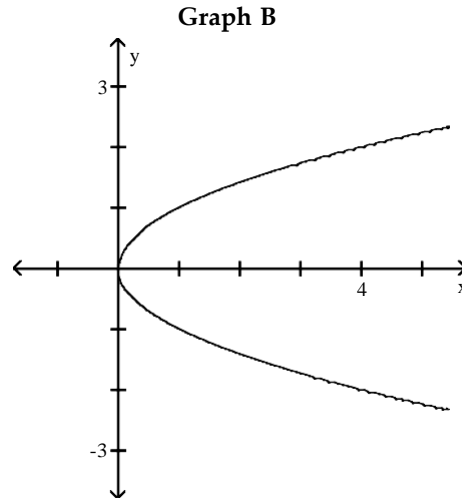
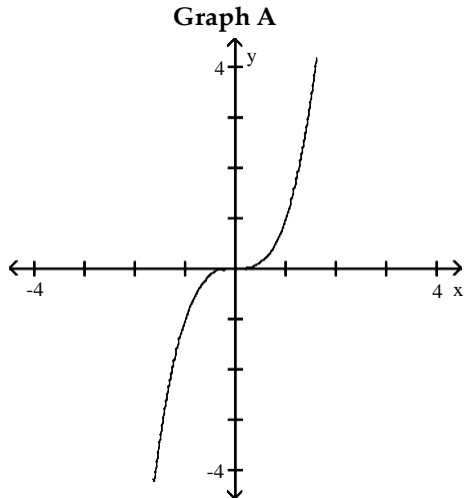

- 337) Which one is the graph of $y = \sqrt{x}$? What is its domain?
- A) graph A; $(-\infty, \infty)$
 - B) graph B; $[0, \infty)$
 - C) graph C; $\{-2, -1, 0, 1, 2\}$
 - D) graph D; $[0, \infty)$

Answer: D

- 338) Which one is the graph of $y = \lceil x \rceil$? What is the value of y when $x = -0.5$?
- A) graph D; -1
 - B) graph A; 0.25
 - C) graph C; -1
 - D) graph B; 0.25

Answer: C

339) Which one is the graph of $y = x^3$? What is its range?

- A) graph A; $(-\infty, \infty)$
- B) graph C; $[-2, 2]$
- C) graph B; $(-\infty, \infty)$
- D) graph D; $[0, \infty)$

Answer: A

340) Which is not the graph of a function? What is its equation?

- A) graph B; $x = y^2$
- B) graph A; $y = x$
- C) graph D; $y = \lceil x \rceil$
- D) graph C; $y = \sqrt{x}$

Answer: A

341) Which one is discontinuous over its domain? What is its range?

- A) graph C; $\{-2, -1, 0, 1, 2\}$
- B) graph B; $[0, \infty)$
- C) graph C; $(-\infty, \infty)$
- D) graph B; $(-\infty, \infty)$

Answer: A

342) Which graphs of functions increase over the whole of their domain?

- A) graphs C and D
- B) graphs A and B
- C) graphs A and D
- D) graph D

Answer: C

Determine the intervals of the domain over which the function is continuous.

343) P(1, 0)

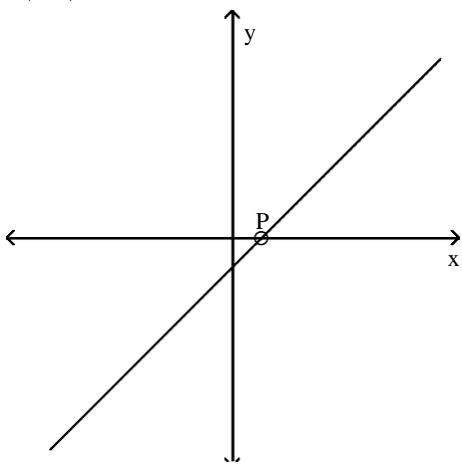

- A) $(-\infty, 1) \cup (1, \infty)$
- B) $(-\infty, 1] \cup [1, \infty)$
- C) $(-\infty, \infty)$
- D) $(-\infty, 0) \cup (0, \infty)$

Answer: A

344)

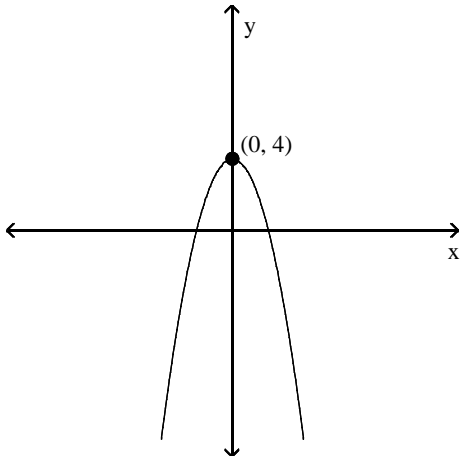

- A) $(4, \infty)$
- B) $(-\infty, 4]$
- C) $(-\infty, \infty)$
- D) $[0, \infty)$

Answer: C

345)

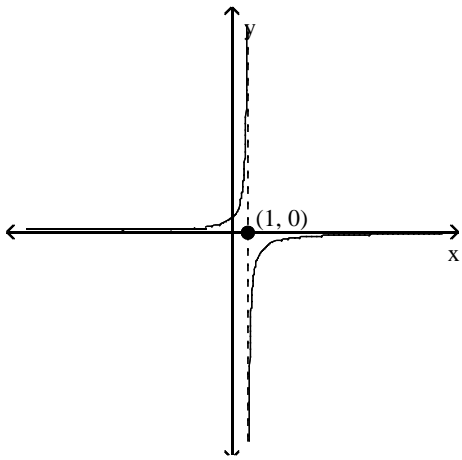

- A) $(-\infty, 1) \cup (1, \infty)$
- B) $(-\infty, 0) \cup (0, \infty)$
- C) $(-\infty, 1] \cup [1, \infty)$
- D) $(-\infty, \infty)$

Answer: A

346)

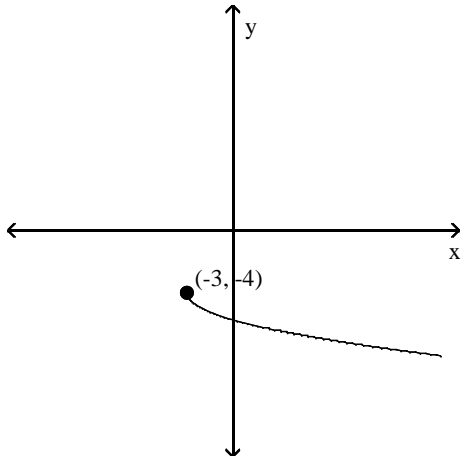

- A) $(-\infty, \infty)$
- B) $[-3, \infty)$
- C) $(-\infty, -3) \cup (-3, \infty)$
- D) $[-4, \infty)$

Answer: B

347)

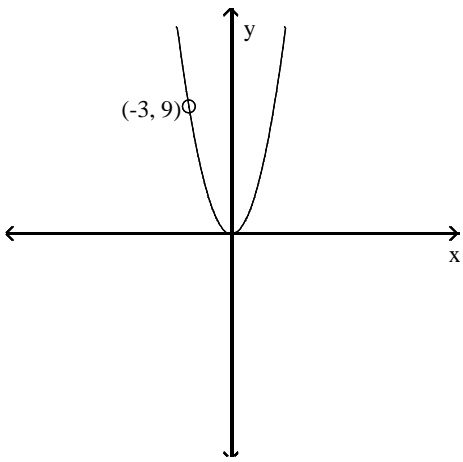

- A) $(-\infty, \infty)$
- B) $(-\infty, 9) \cup (9, \infty)$
- C) $[0, \infty]$
- D) $(-\infty, -3) \cup (-3, \infty)$

Answer: D

348)

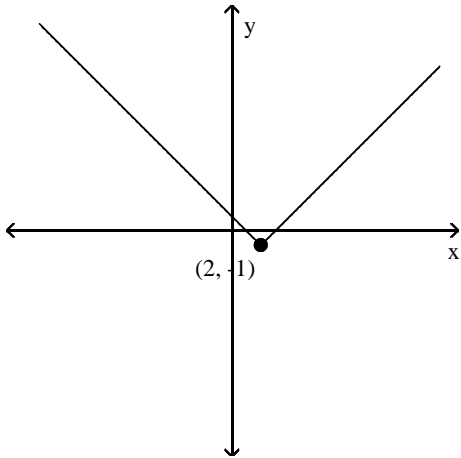

- A) $(-\infty, \infty)$
- B) $(-\infty, 2) \cup (2, \infty)$
- C) $(-\infty, -1) \cup (-1, \infty)$
- D) $[2, \infty)$

Answer: A

Find the requested value.

349) $f(-6)$ for $f(x) = \begin{cases} 2x, & \text{if } x \leq -1 \\ x - 3, & \text{if } x > -1 \end{cases}$

- A) 3
- B) -12
- C) -9
- D) 12

Answer: B

350) $f(8)$ for $f(x) = \begin{cases} 7x + 2, & \text{if } x \leq 0 \\ 7 - 7x, & \text{if } 0 < x < 7 \\ x, & \text{if } x \geq 7 \end{cases}$

- A) 58
- B) 7
- C) -49
- D) 8

Answer: D

351) $f(6)$ for $f(x) = \begin{cases} 2x + 1, & \text{if } x < 1 \\ 6x, & \text{if } 6 \leq x \leq 10 \\ 6 - 6x, & \text{if } x > 10 \end{cases}$

- A) 3
- B) 61
- C) -30
- D) 36

Answer: D

$$352) f(-8) \text{ for } f(x) = \begin{cases} 2x + 1, & \text{if } x < 8 \\ 8x, & \text{if } 8 \leq x \leq 10 \\ 8 - 7x, & \text{if } x > 10 \end{cases}$$

- A) -15
- B) 17
- C) -64
- D) 64

Answer: A

Graph the function.

$$353) f(x) = \begin{cases} 3, & \text{if } x \geq 1 \\ -1 - x, & \text{if } x < 1 \end{cases}$$

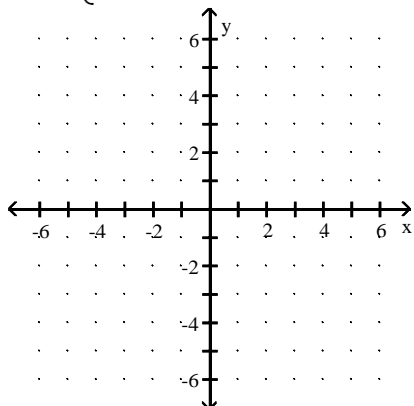

A)

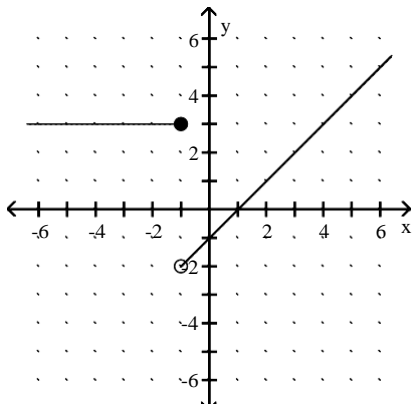

B)

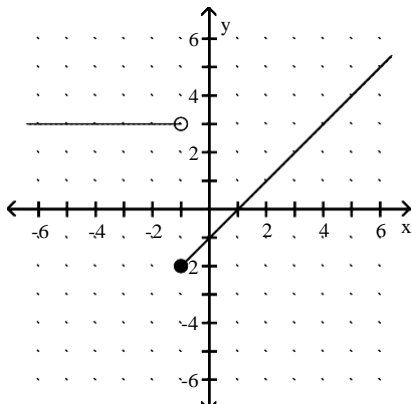

C)

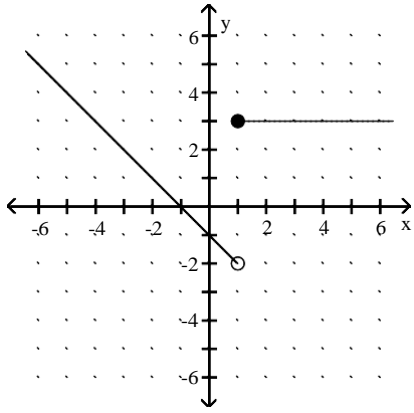

D)

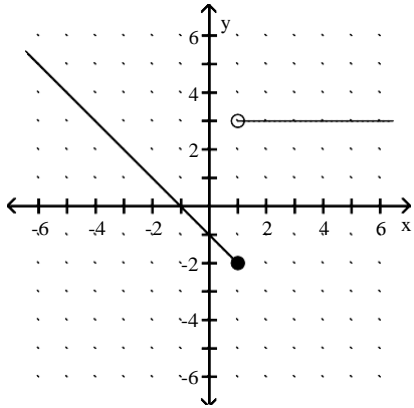

Answer: C

$$354) f(x) = \begin{cases} 9, & \text{if } x > 3 \\ -9, & \text{if } x \leq 3 \end{cases}$$

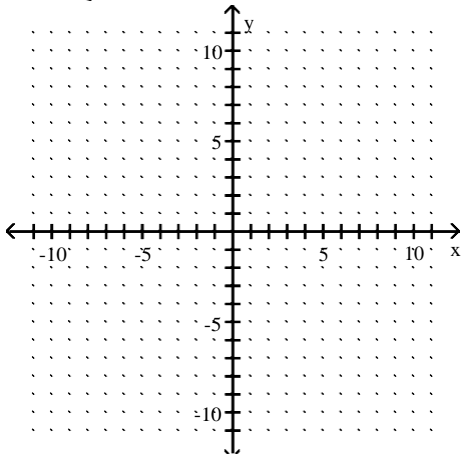

A)

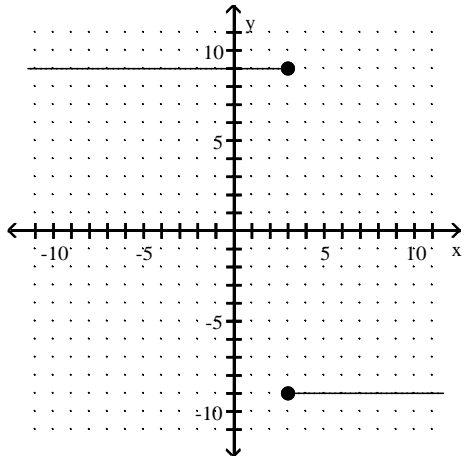

B)

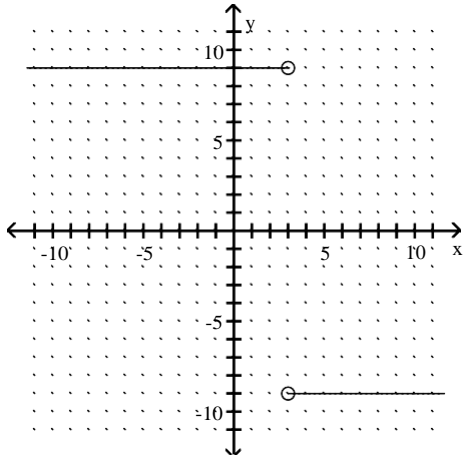

C)

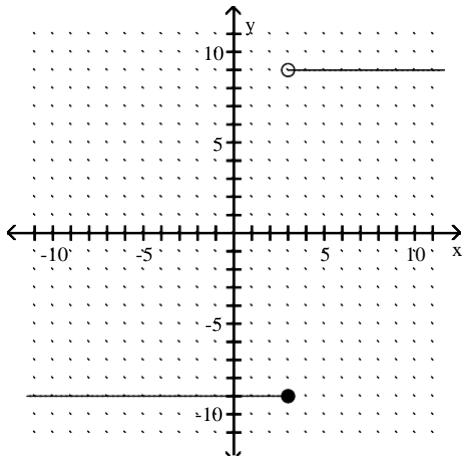

D)

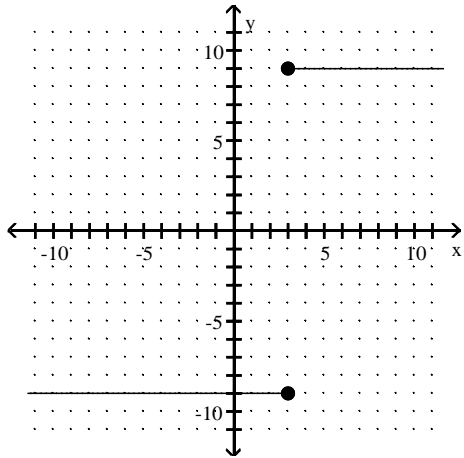

Answer: C

$$355) f(x) = \begin{cases} x - 4, & \text{if } x > 0 \\ 3, & \text{if } x \leq 0 \end{cases}$$

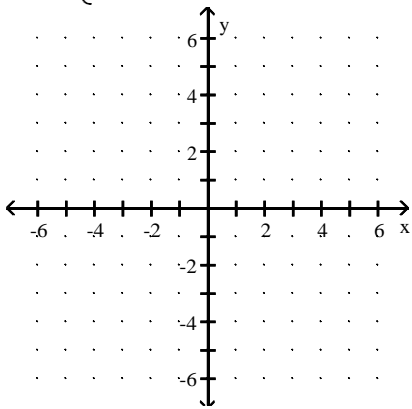

A)

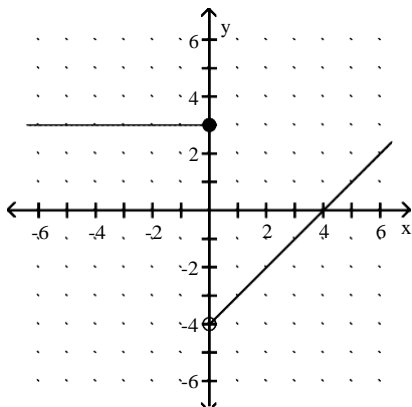

B)

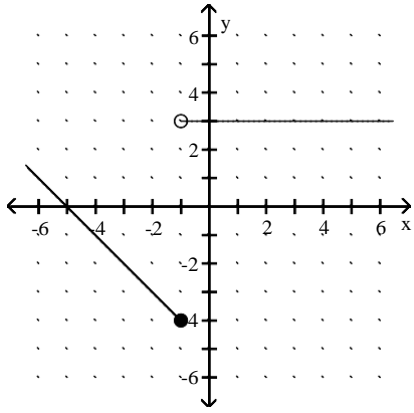

C)

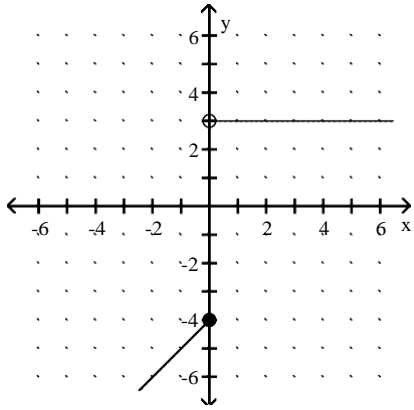

D)

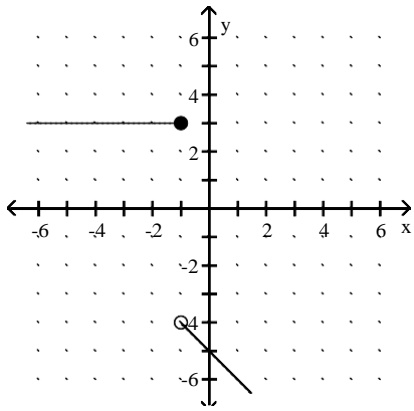

Answer: A

$$356) f(x) = \begin{cases} 6x + 2, & \text{if } x < 0 \\ 2x^2 - 2 & \text{if } x \geq 0 \end{cases}$$

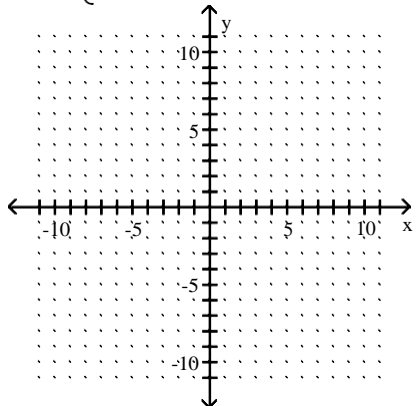

A)

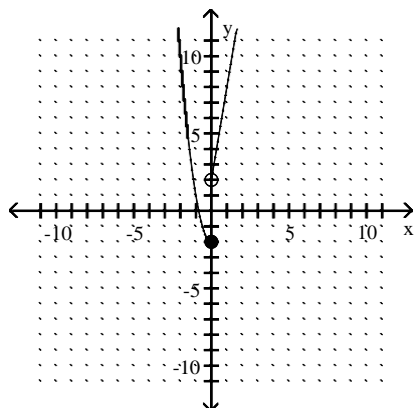

B)

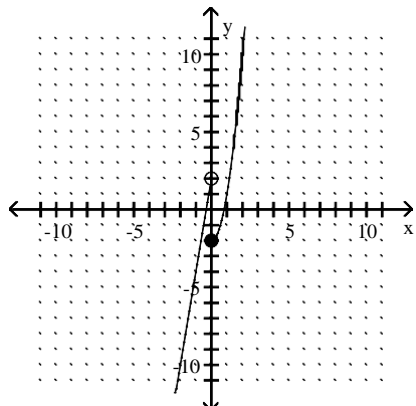

C)

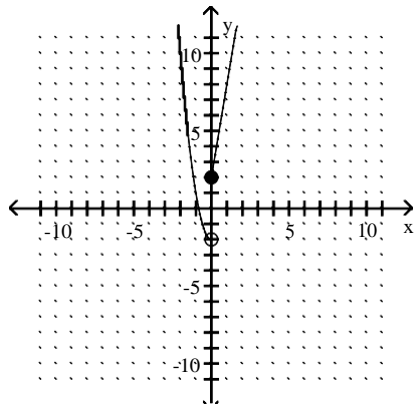

D)

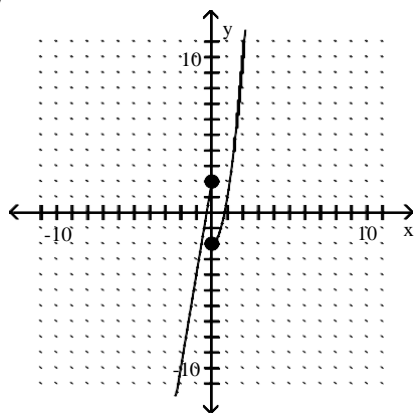

Answer: B

$$357) f(x) = \begin{cases} x^2 - 9, & \text{if } x < -1 \\ 0, & \text{if } -1 \leq x \leq 1 \\ x^2 + 9, & \text{if } x > 1 \end{cases}$$

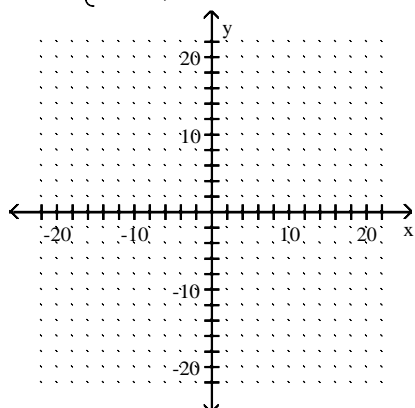

A)

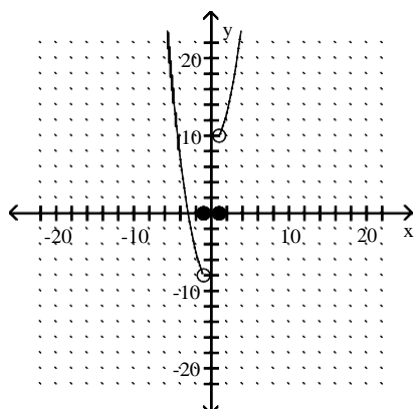

B)

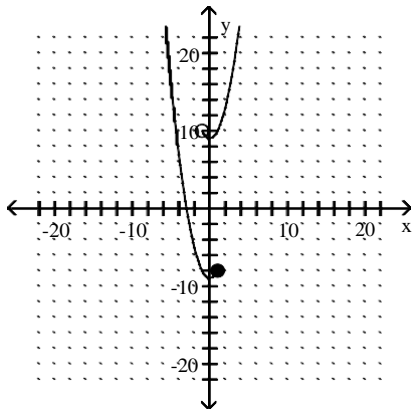

C)

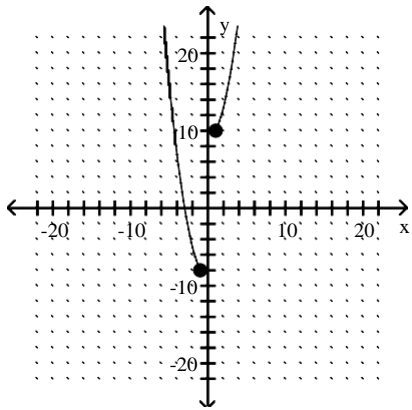

D)

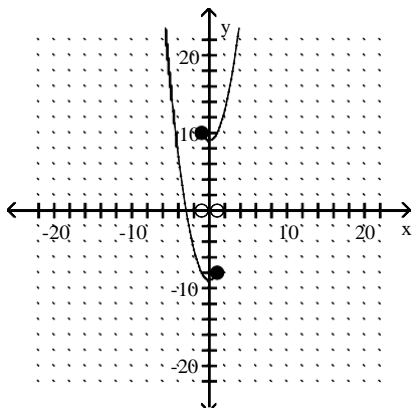

Answer: A

$$358) f(x) = \begin{cases} 3x^2, & \text{if } x \leq -1 \\ 3, & \text{if } -1 < x < 1 \\ 3x + 1, & \text{if } x \geq 1 \end{cases}$$

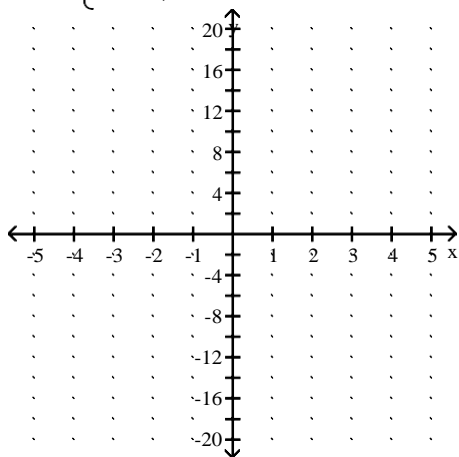

A)

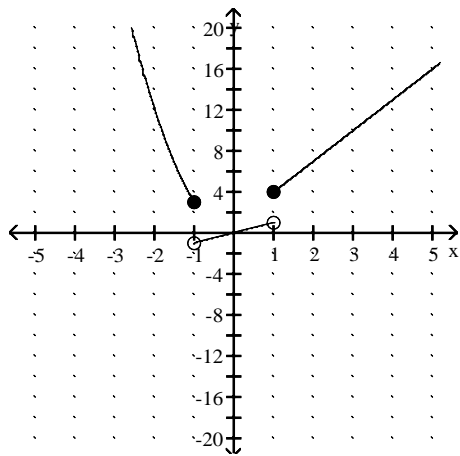

B)

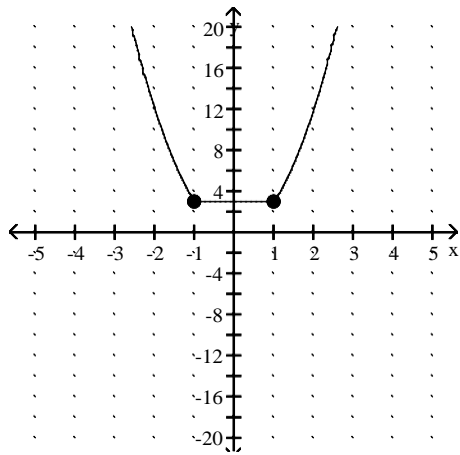

C)

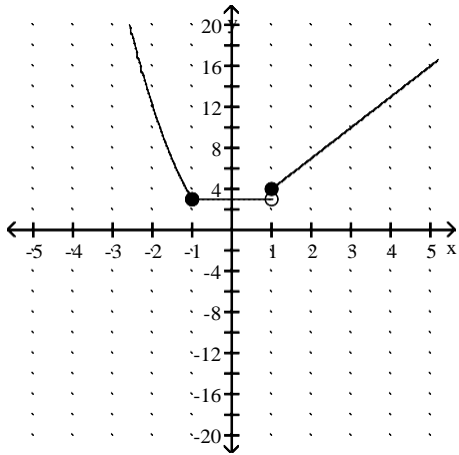

D)

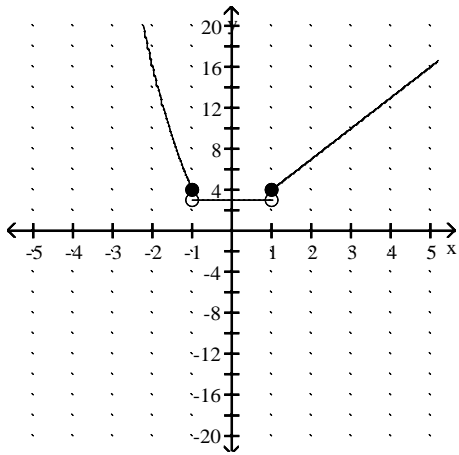

Answer: C

Give a rule for the piecewise-defined function. Then give the domain and range.

359)

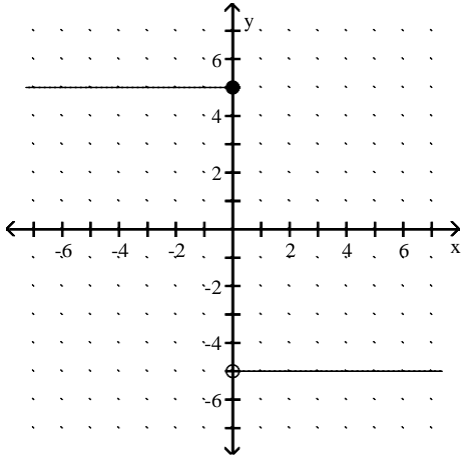

A) $f(x) = \begin{cases} 5 & \text{if } x \leq 0 \\ -5 & \text{if } x > 0 \end{cases}$; Domain: $(-\infty, \infty)$, Range: $\{-5, 5\}$

B) $f(x) = \begin{cases} -5 & \text{if } x \leq 0 \\ 5 & \text{if } x > 0 \end{cases}$; Domain: $\{-5, 5\}$, Range: $(-\infty, \infty)$

C) $f(x) = \begin{cases} 5 & \text{if } x < 0 \\ -5 & \text{if } x \geq 0 \end{cases}$; Domain: $(-\infty, \infty)$, Range: $\{-5, 5\}$

D) $f(x) = \begin{cases} 5x & \text{if } x \leq 0 \\ -5x & \text{if } x > 0 \end{cases}$; Domain: $\{-5, 5\}$, Range: $(-\infty, \infty)$

Answer: A

169)

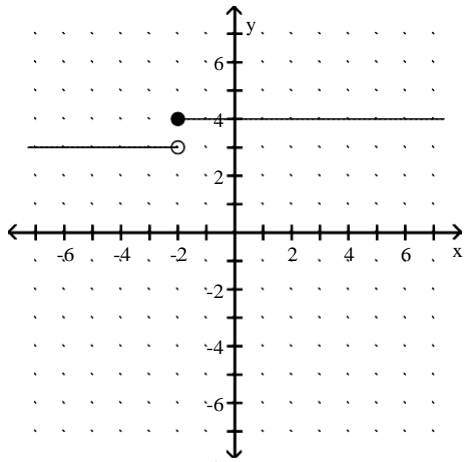

A) $f(x) = \begin{cases} 3 & \text{if } x < -2 \\ 4 & \text{if } x \geq -2 \end{cases}$; Domain: $(-\infty, \infty)$, Range: $\{3, 4\}$

B) $f(x) = \begin{cases} 3 & \text{if } x < -2 \\ 4 & \text{if } x \geq -2 \end{cases}$; Domain: $\{3, 4\}$, Range: $(-\infty, \infty)$

C) $f(x) = \begin{cases} 3 & \text{if } x \leq -2 \\ 4 & \text{if } x > -2 \end{cases}$; Domain: $\{3, 4\}$, Range: $(-\infty, \infty)$

D) $f(x) = \begin{cases} 3 & \text{if } x \leq -2 \\ 4 & \text{if } x > -2 \end{cases}$; Domain: $(-\infty, \infty)$, Range: $\{3, 4\}$

Answer: A

170)

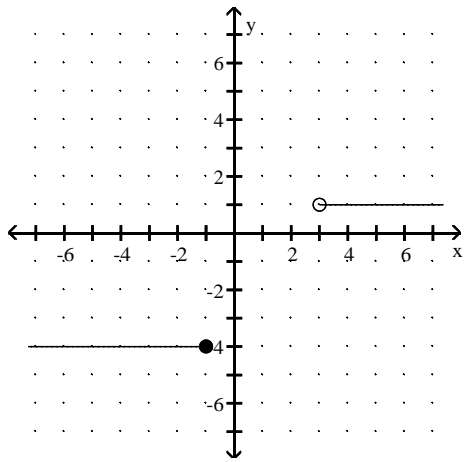

A) $f(x) = \begin{cases} -4 & \text{if } x < -1 \\ 1 & \text{if } x \geq 3 \end{cases}$; Domain: $\{-4, 1\}$, Range: $(-\infty -1) \cup [3, \infty)$

B) $f(x) = \begin{cases} -4 & \text{if } x \leq -1 \\ 1 & \text{if } x > 3 \end{cases}$; Domain: $\{-4, 1\}$, Range: $(-\infty -1] \cup (3, \infty)$

C) $f(x) = \begin{cases} -4 & \text{if } x \leq -1 \\ 1 & \text{if } x > 3 \end{cases}$; Domain: $(-\infty -1] \cup (3, \infty)$, Range: $\{-4, 1\}$

D) $f(x) = \begin{cases} -4 & \text{if } x < -1 \\ 1 & \text{if } x \geq 3 \end{cases}$; Domain: $(-\infty -1) \cup [3, \infty)$, Range: $\{-4, 1\}$

Answer: C

171)

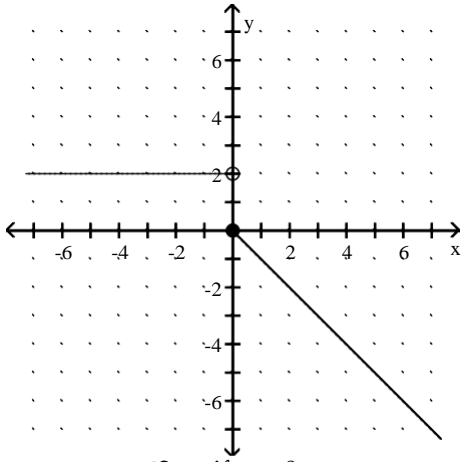

A) $f(x) = \begin{cases} 2 & \text{if } x < 0 \\ -2x & \text{if } x \geq 0 \end{cases}$; Domain: $(-\infty, 0) \cup \{2\}$, Range: $(-\infty, \infty)$

B) $f(x) = \begin{cases} 2 & \text{if } x < 0 \\ -x & \text{if } x \geq 0 \end{cases}$; Domain: $(-\infty, \infty)$, Range: $(-\infty, 0] \cup \{2\}$

C) $f(x) = \begin{cases} 2 & \text{if } x \leq 0 \\ -x & \text{if } x > 0 \end{cases}$; Domain: $(-\infty, \infty)$, Range: $(-\infty, 0) \cup \{2\}$

D) $f(x) = \begin{cases} 2 & \text{if } x < 0 \\ x & \text{if } x \geq 0 \end{cases}$; Domain: $(-\infty, 0] \cup (2, \infty)$, Range: $(-\infty, \infty)$

Answer: B

172)

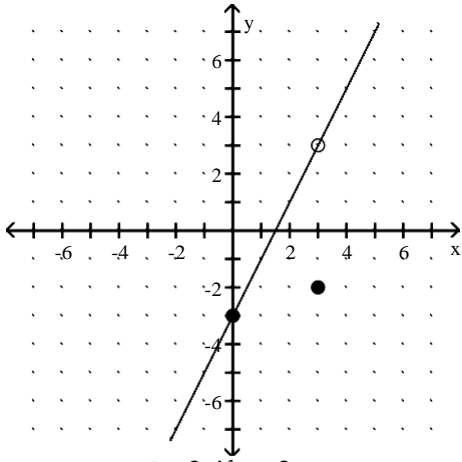

A) $f(x) = \begin{cases} x - 3 & \text{if } x \neq 3 \\ -2 & \text{if } x = 3 \end{cases}$; Domain: $(-\infty, \infty)$, Range: $(-\infty, 3] \cup [3, \infty)$

B) $f(x) = \begin{cases} 2x - 3 & \text{if } x \neq 3 \\ -3 & \text{if } x = 3 \end{cases}$; Domain: $(-\infty, 3] \cup [3, \infty)$, Range: $(-\infty, \infty)$

C) $f(x) = \begin{cases} 2x - 3 & \text{if } x \neq 3 \\ -2 & \text{if } x = 3 \end{cases}$; Domain: $(-\infty, \infty)$, Range: $(-\infty, 3) \cup (3, \infty)$

D) $f(x) = \begin{cases} 2x - 3 & \text{if } x < 3 \\ 2x + 3 & \text{if } x \geq 3 \end{cases}$; Domain: $(-\infty, 3) \cup (3, \infty)$, Range: $(-\infty, \infty)$

Answer: C

173)

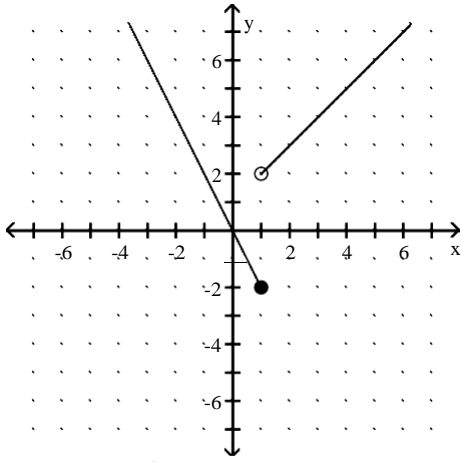

A) $f(x) = \begin{cases} -2x & \text{if } x \leq 1 \\ x + 2 & \text{if } x > 1 \end{cases}$; Domain: $(-\infty, 2) \cup (2, \infty)$, Range: $(-\infty, \infty)$

B) $f(x) = \begin{cases} -x & \text{if } x \leq 1 \\ 2x + 1 & \text{if } x > 1 \end{cases}$; Domain: $(-\infty, \infty)$, Range: $(-\infty, 2) \cup (2, \infty)$

C) $f(x) = \begin{cases} 2x & \text{if } x \leq 1 \\ x + 1 & \text{if } x > 1 \end{cases}$; Domain: $(-\infty, \infty)$, Range: $(-\infty, \infty)$

D) $f(x) = \begin{cases} -2x & \text{if } x \leq 1 \\ x + 1 & \text{if } x > 1 \end{cases}$; Domain: $(-\infty, \infty)$, Range: $(-\infty, \infty)$

Answer: D

Graph the function.

365) $f(x) = \lfloor \frac{x}{2} \rfloor + 1$

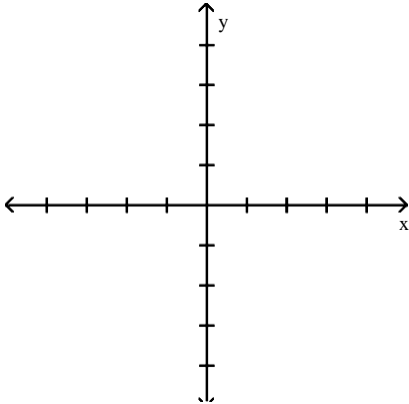

A)

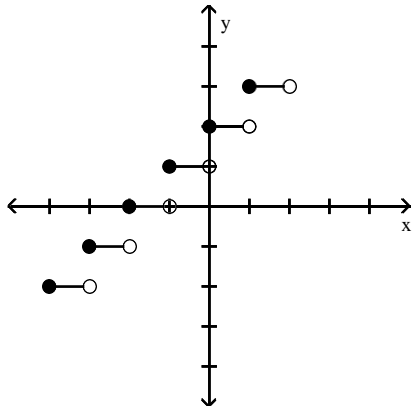

B)

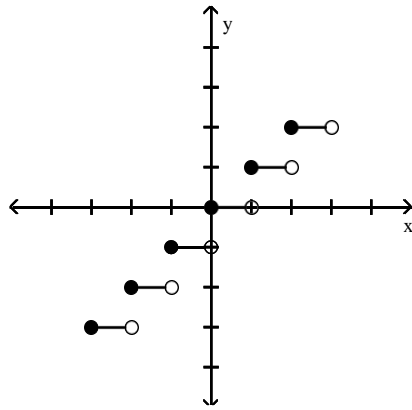

C)

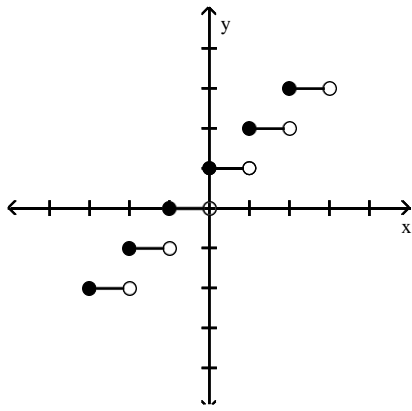

D)

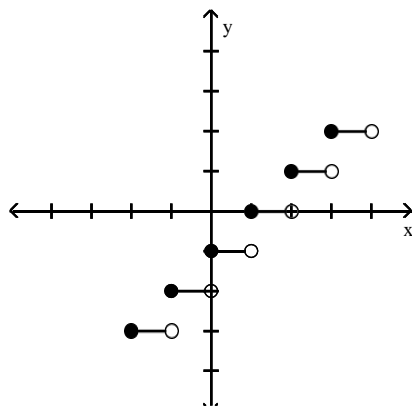

Answer: C

366) $f(x) = \lfloor x + 1 \rfloor$

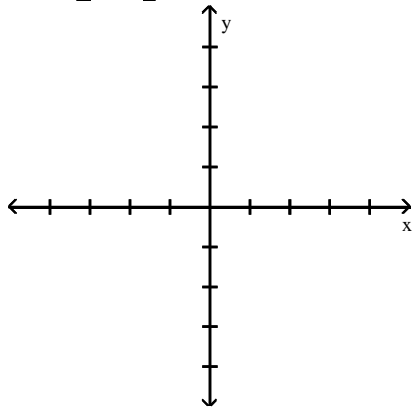

A)

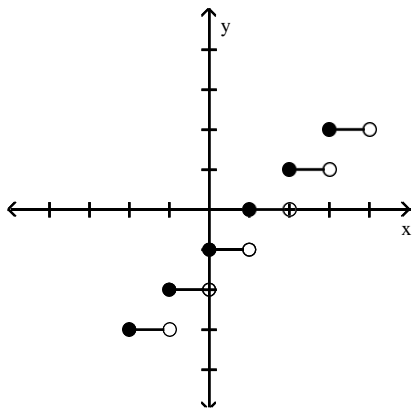

B)

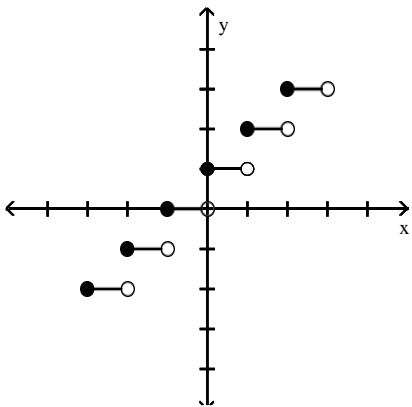

C)

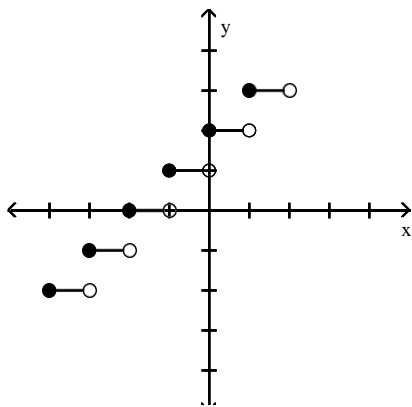

D)

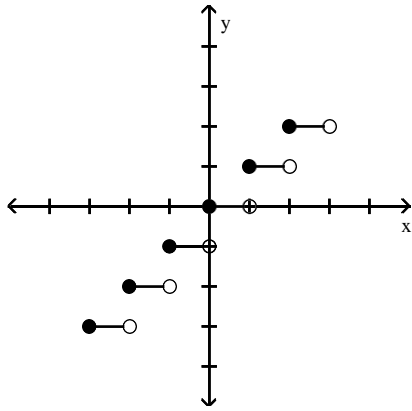

Answer: B

367) $f(x) = \lceil x \rceil - 1$

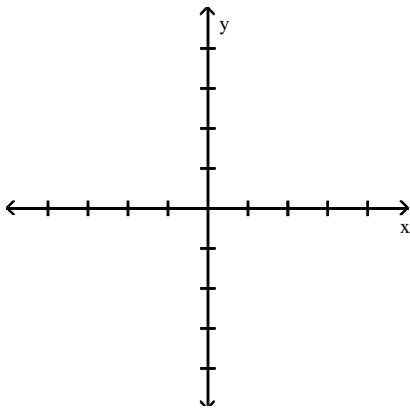

A)

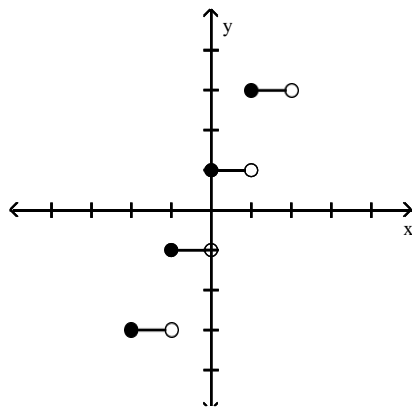

B)

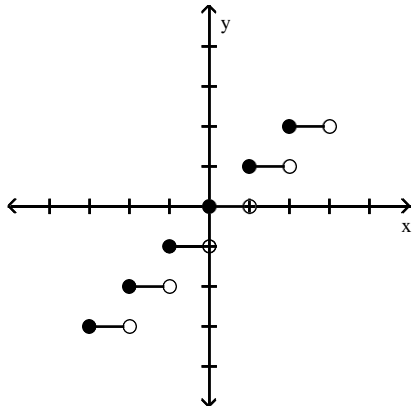

C)

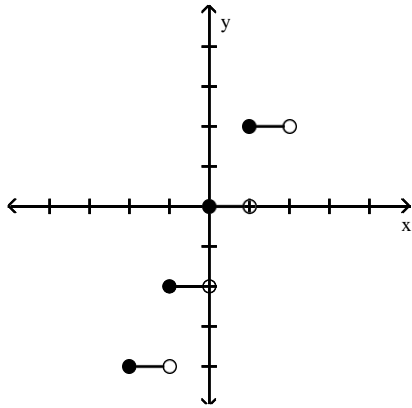

D)

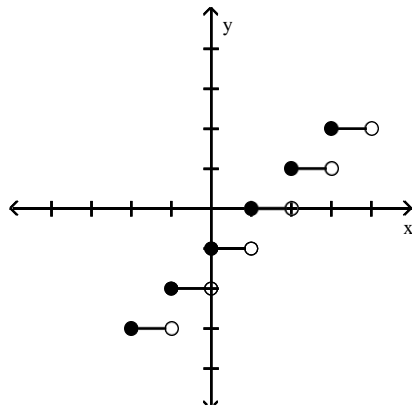

Answer: D

368) $f(x) = \llbracket x - 1 \rrbracket$

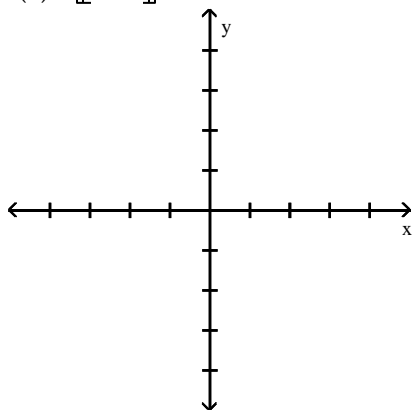

A)

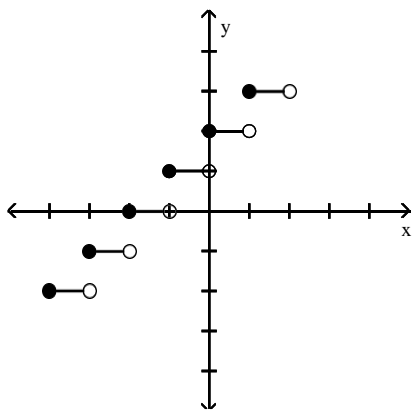

B)

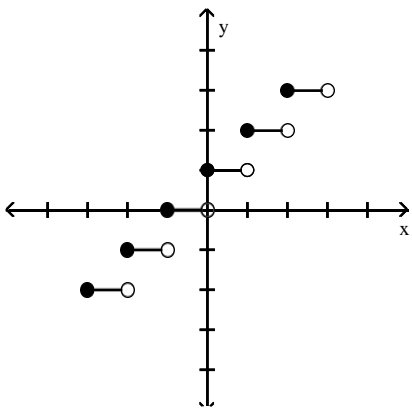

C)

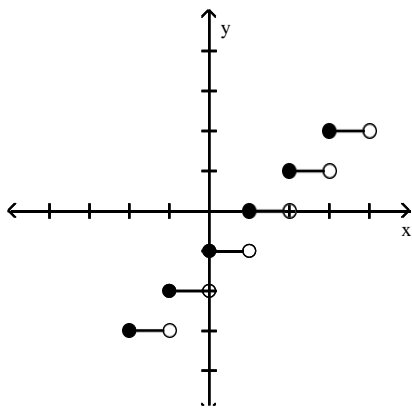

D)

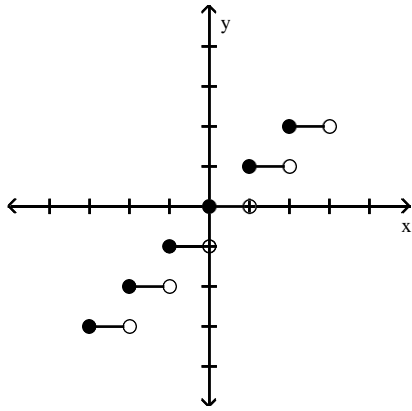

Answer: C

369) $f(x) = 2\lceil x \rceil$

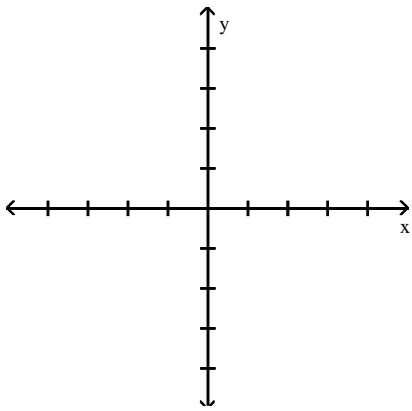

A)

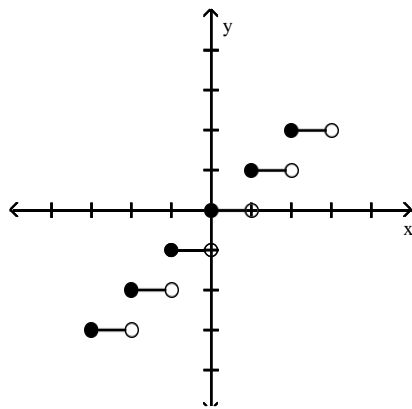

B)

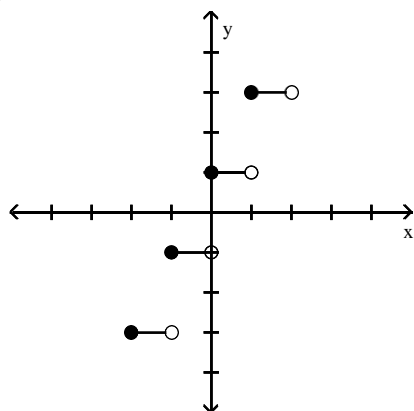

C)

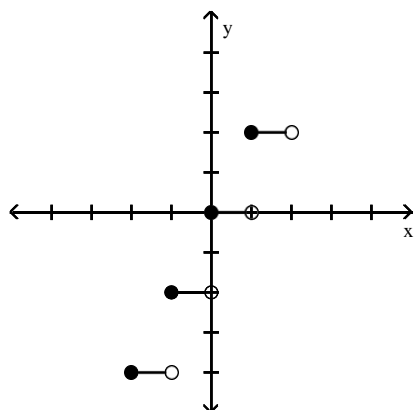

D)

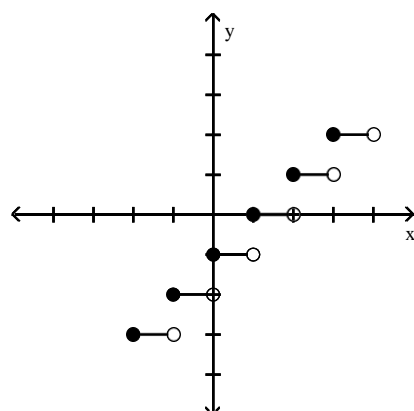

Answer: C

Solve the problem.

370) Employees of a publishing company received an increase in salary of 8% plus a bonus of \$800. Let $S(x)$ represent the new salary in terms of the previous salary x . Find the value of $S(24,000)$.

- A) \$26,720
- B) \$21,481
- C) \$44,000
- D) \$24,800

Answer: A

371) Assume it costs 25 cents to mail a letter weighing one ounce or less, and then 20 cents for each additional ounce or fraction of an ounce. Let $L(x)$ be the cost of mailing a letter weighing x ounces. Graph $y = L(x)$.

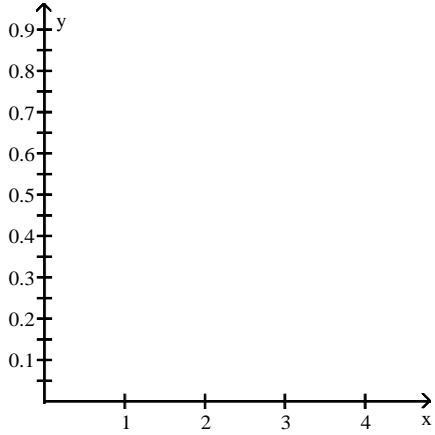

A)

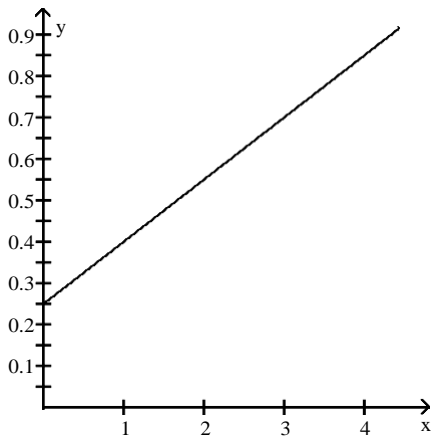

B)

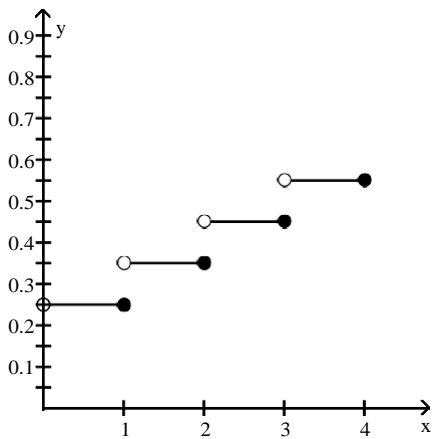

C)

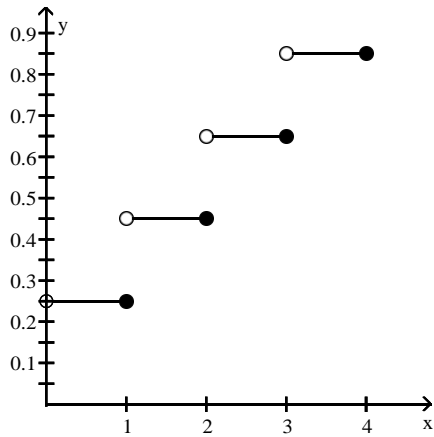

D)

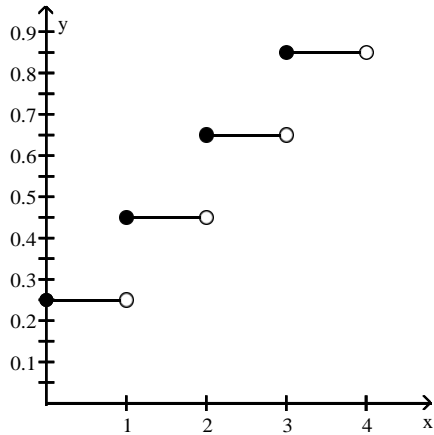

Answer: C

372) A video rental company charges \$4 per day for renting a video tape, and then \$3 per day after the first. Use the greatest integer function and write an expression for renting a video tape for x days.

- A) $y = \lceil 3x + 4 \rceil$
- B) $y + 4 = 3\lceil x \rceil$
- C) $y = 3\lceil x - 1 \rceil + 4$
- D) $y = 3x + 4$

Answer: C

373) Suppose a car rental company charges \$134 for the first day and \$84 for each additional or partial day. Let $S(x)$ represent the cost of renting a car for x days. Find the value of $S(3.5)$.

- A) \$386
- B) \$428
- C) \$344
- D) \$294

Answer: A

- 374) Suppose a life insurance policy costs \$12 for the first unit of coverage and then \$3 for each additional unit of coverage. Let $C(x)$ be the cost for insurance of x units of coverage. What will 10 units of coverage cost?
- A) \$42
 - B) \$30
 - C) \$39
 - D) \$18

Answer: C

- 375) The charges for renting a moving van are \$50 for the first 30 miles and \$8 for each additional mile. Assume that a fraction of a mile is rounded up. (i) Determine the cost of driving the van 82 miles. (ii) Find a symbolic representation for a function f that computes the cost of driving the van x miles, where $0 < x \leq 100$. (Hint: express f as a piecewise-constant function.)

- A) \$946; $f(x) = \begin{cases} 50 & \text{if } 0 < x \leq 30 \\ 50 + 8(x - 30) & \text{if } 30 < x \leq 100 \end{cases}$
- B) \$4516; $f(x) = \begin{cases} 50x & \text{if } 0 < x \leq 30 \\ 50 + 8(x - 30) & \text{if } 30 < x \leq 100 \end{cases}$
- C) \$946; $f(x) = \begin{cases} 50 & \text{if } 0 < x \leq 30 \\ 50 + 8(x + 30) & \text{if } 30 < x \leq 100 \end{cases}$
- D) \$466; $f(x) = \begin{cases} 50 & \text{if } 0 < x \leq 30 \\ 50 + 8(x - 30) & \text{if } 30 < x \leq 100 \end{cases}$

Answer: D

- 376) Sketch a graph showing the distance (in miles) that a person is from home after x hours if that individual drives at 35 mph to a lake 70 miles away, stays at the lake 1.5 hours, and then returns home at a speed of 70 mph.

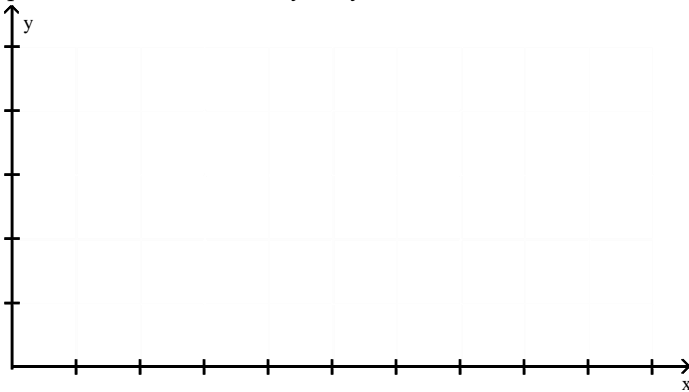

A)

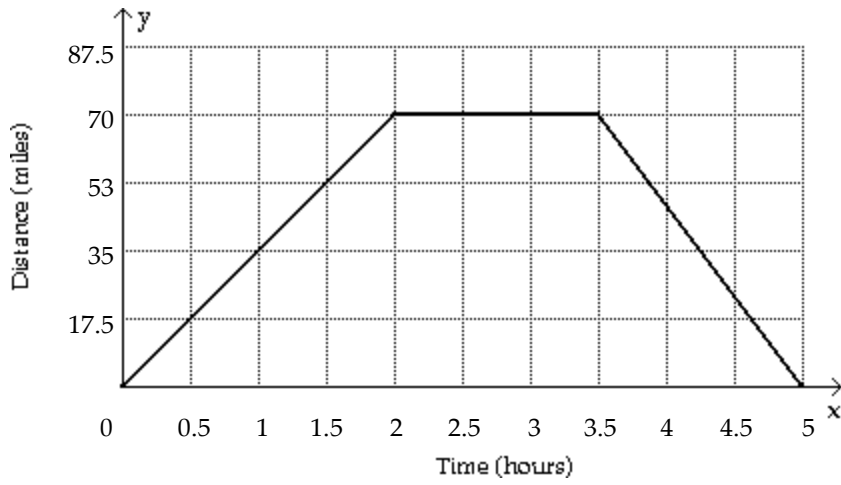

B)

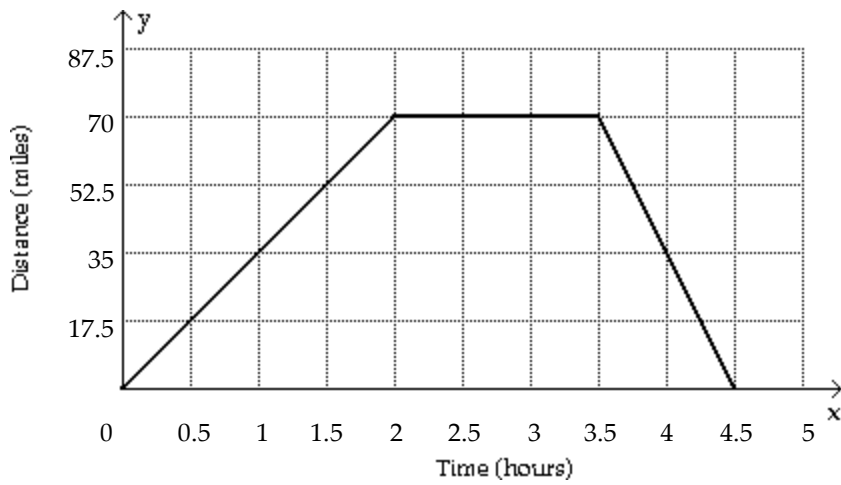

C) none of these

D)

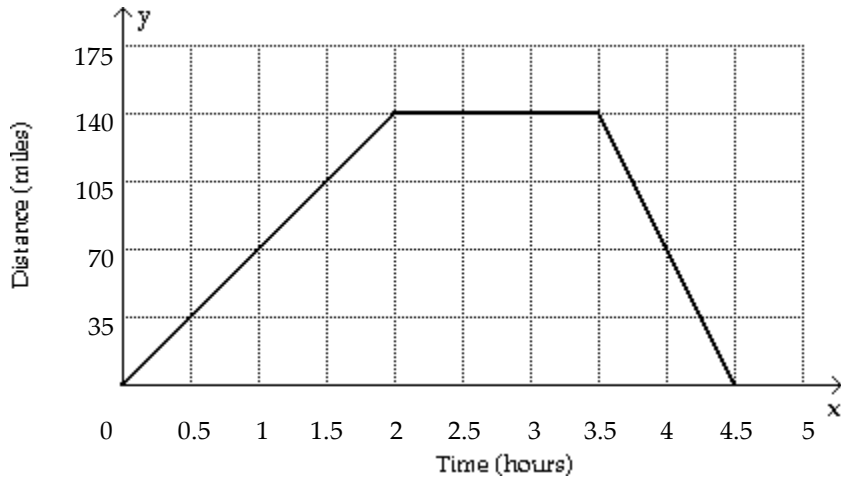

Answer: B

377) The table lists the average composite scores on a national entrance exam for selected years.

Year	2	4	6	8	10	12	14
Score	122.7	131.5	131.5	129.5	133.9	132.0	130.0

(i) Make a line graph of the data.

(ii) If the graph represents a piecewise-linear function f , find a symbolic representation for the piece of f located on the interval $[4, 6]$.

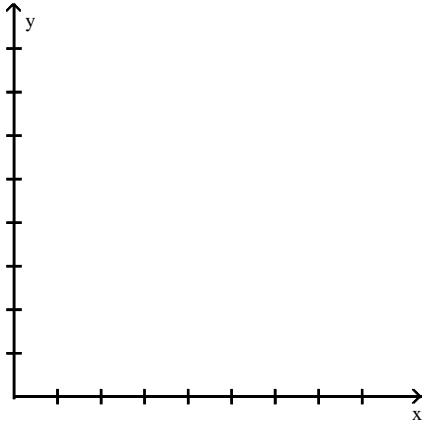

A) $f(x) = 0.75x - 1355$ if $4 \leq x \leq 8$

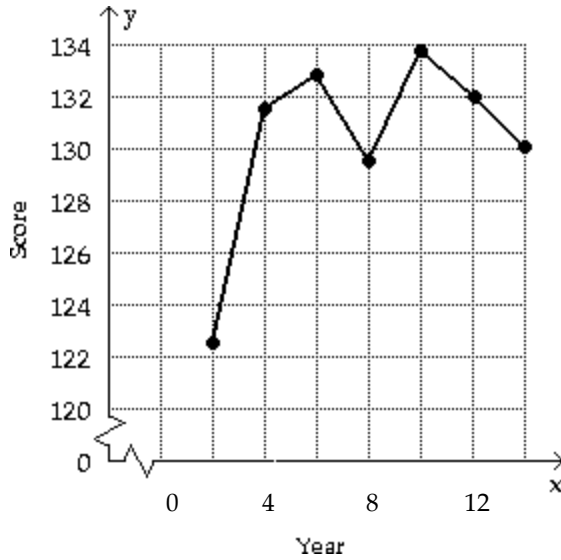

B) $f(x) = 131.5$ if $4 \leq x \leq 6$

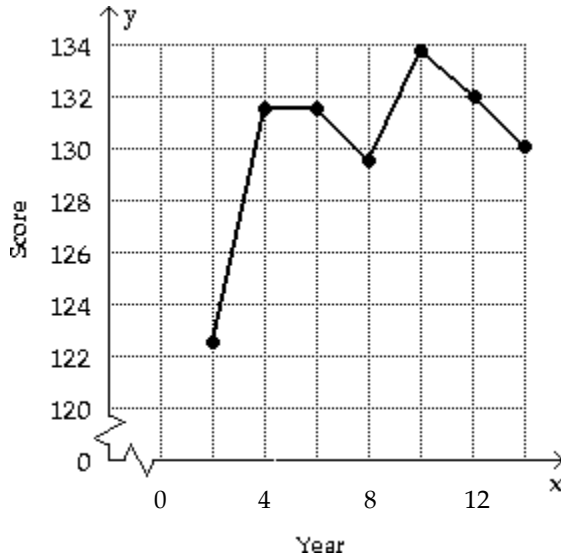

C) $f(x) = 4.4x - 8589.3$ if $8 \leq x \leq 10$

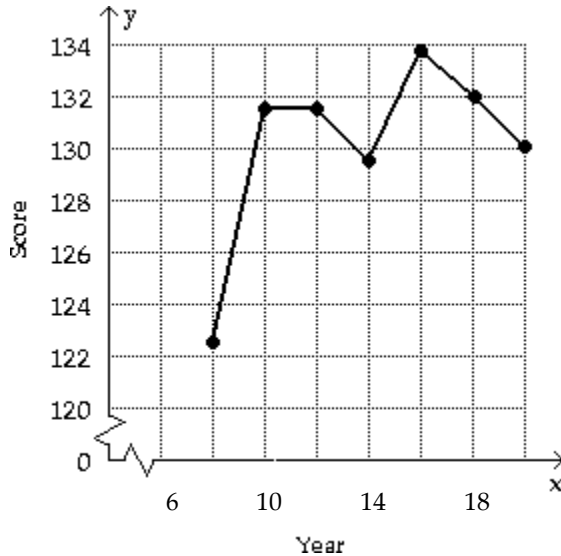

D) none of these

Answer: B

378) In Country X, the average hourly wage in dollars from 1960 to 2010 can be modeled by

$$f(x) = \begin{cases} 0.073(x - 1960) + 0.38 & \text{if } 1960 \leq x < 1995 \\ 0.185(x - 1995) + 3.04 & \text{if } 1995 \leq x \leq 2010 \end{cases}$$

Use f to estimate the average hourly wages in 1965, 1985, and 2005.

- A) \$0.75, \$2.21, \$6.74
- B) \$3.41, \$0.38, \$6.74
- C) \$0.75, \$3.04, \$6.74

Answer: C

Describe how the graph of the equation relates to the graph of $y = x^2$.

379) $f(x) = (x - 6)^2$

- A) a translation 6 units down
- B) a translation 6 units to the right
- C) a translation 6 units to the left
- D) a translation 6 units up

Answer: B

380) $f(x) = x^2 + 5$

- A) a translation 5 units up
- B) a translation 5 units to the right
- C) a translation 5 units to the left
- D) a translation 5 units down

Answer: A

381) $f(x) = 5x^2$

- A) a horizontal stretch by a factor of 5
- B) a translation 5 units to the right
- C) a vertical stretch by a factor of 5
- D) a translation 5 units up

Answer: C

382) $f(x) = -(x + 5)^2$

- A) a translation 5 units to the right and a reflection across the y-axis
- B) a translation 5 units to the right and a reflection across the x-axis
- C) a translation 5 units to the left and a reflection across the x-axis
- D) a translation 5 units up and a reflection across the x-axis

Answer: C

383) $f(x) = (x - 8)^2 + 7$

- A) a translation 8 units to the left and 7 units up
- B) a translation 8 units to the left and 7 units down
- C) a translation 8 units to the right and 7 units up
- D) a translation 7 units to the right and 8 units up

Answer: C

384) $f(x) = \frac{1}{4}x^2 - 5$

- A) vertical shrinking by a factor of $\frac{1}{4}$ and a translation 5 units down
- B) vertical shrinking by a factor of $\frac{1}{4}$ and a translation 5 units to the left
- C) vertical stretching by a factor of 4 and a translation 5 units down
- D) vertical stretching by a factor of 4 and a translation 5 units to the right

Answer: A

Solve the problem.

385) Select the equation that describes the graph shown.

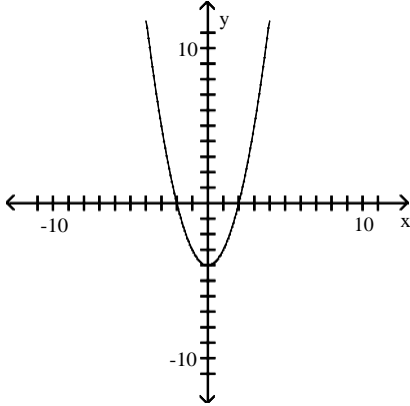

- A) $y = x^2 - 4$
- B) $y = (x - 4)^2 + 1$
- C) $y = (x - 4)^2$
- D) $y = (x + 4)^2$

Answer: A

386) Select the equation that describes the graph shown.

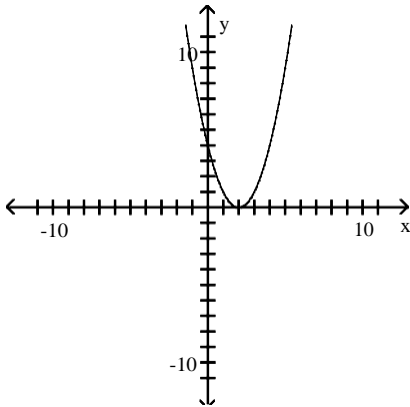

- A) $y = (x + 2)^2$
- B) $y = (x - 2)^2$
- C) $y = x^2 - 2$
- D) $y = x^2 + 2$

Answer: B

387) Select the equation that describes the graph shown.

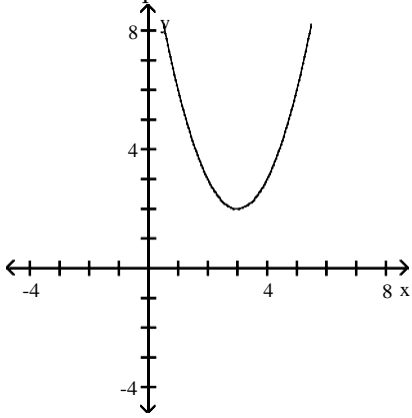

A) $y = (x - 3)^2 + 2$

B) $y = x^2 - 3$

C) $y = (x + 2)^2 - 3$

D) $y = (x + 3)^2 + 2$

Answer: A

388)

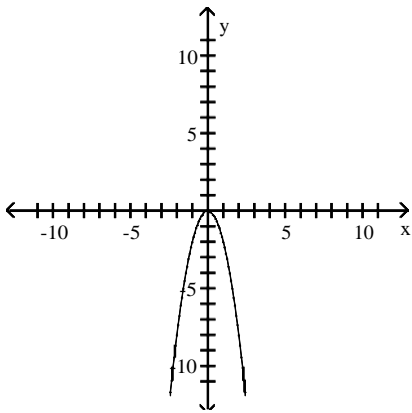

A) $y = -2x^2$

B) $y = -\frac{1}{2}x^2$

C) $y = -x^2$

D) $y = 2x^2$

Answer: A

389) Select the equation that describes the graph shown.

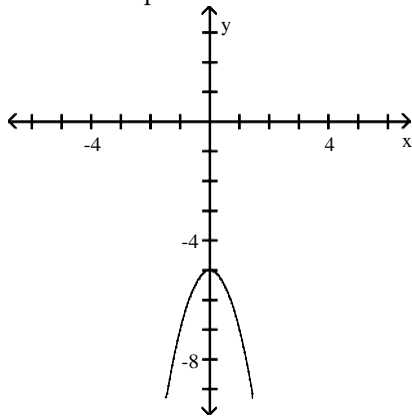

A) $y = -2(x - 5)^2 + 3$

B) $y = -2(x - 5)^2$

C) $y = -2(x + 5)^2$

D) $y = -2x^2 - 5$

Answer: D

Graph the function.

390) $f(x) = 2x^2$

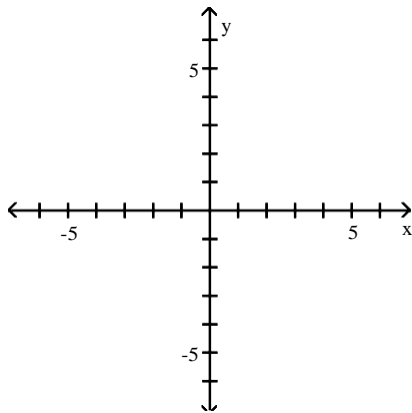

A)

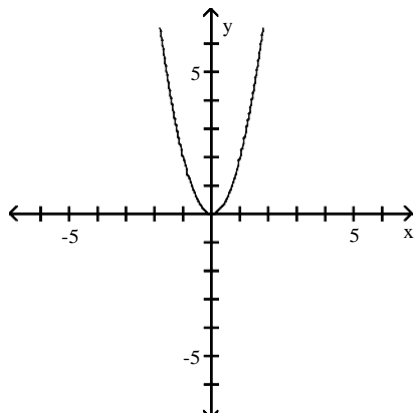

B)

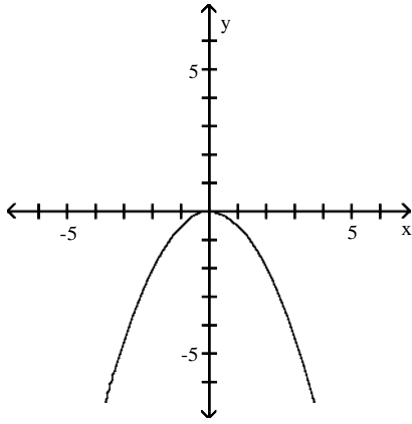

C)

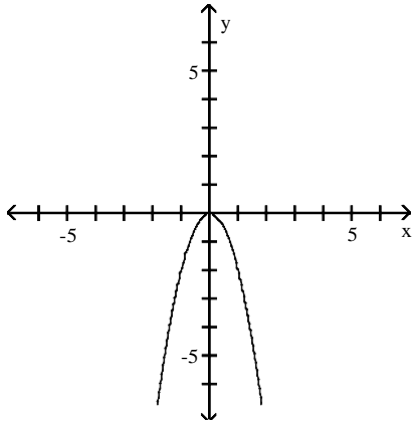

D)

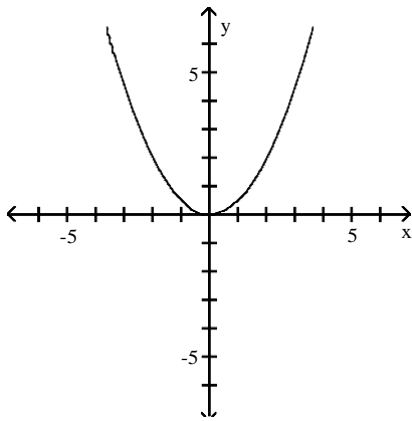

Answer: A

391) $f(x) = \frac{1}{5}x^3$

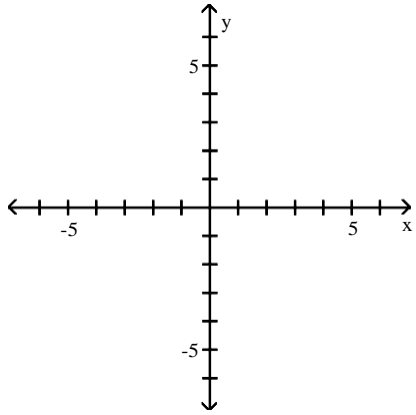

A)

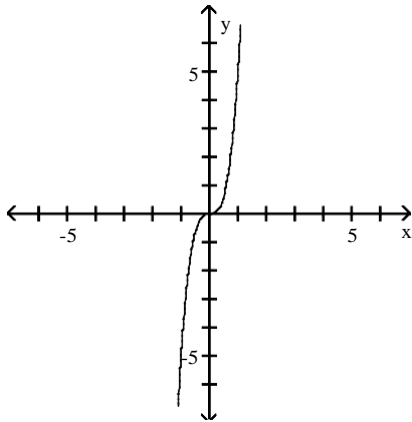

B)

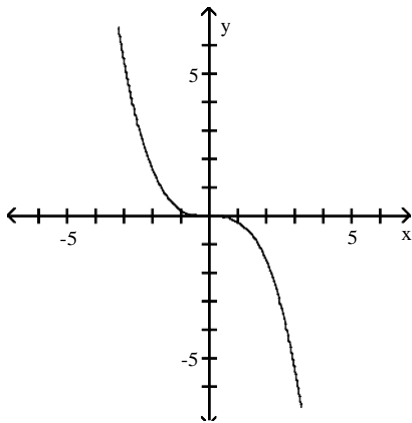

C)

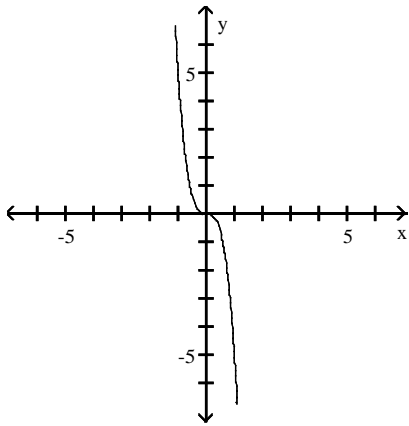

D)

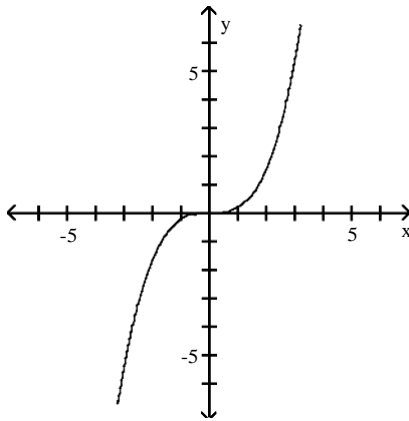

Answer: D

392) $f(x) = 2\sqrt{x}$

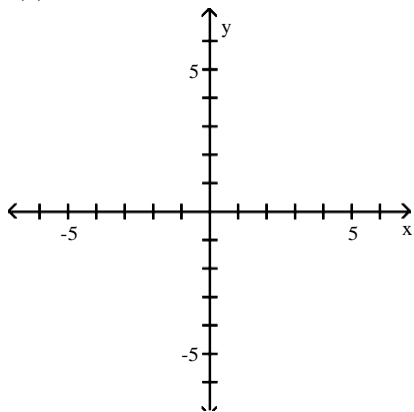

A)

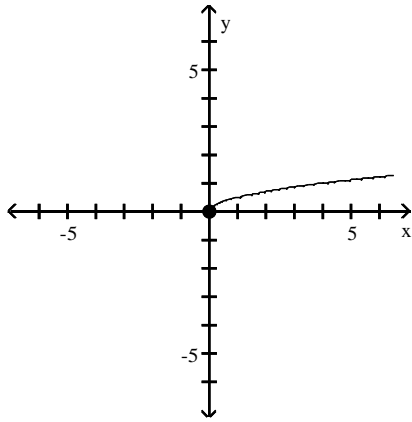

B)

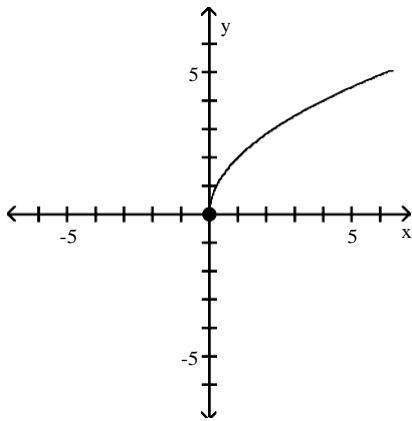

C)

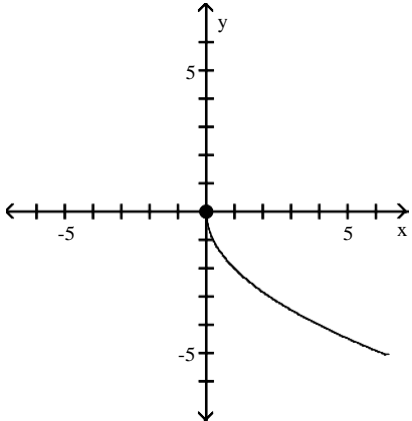

D)

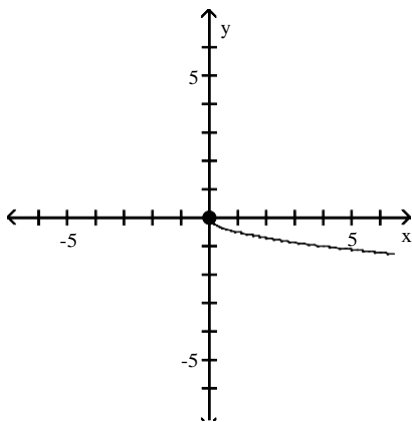

Answer: B

393) $f(x) = (3x)^2$

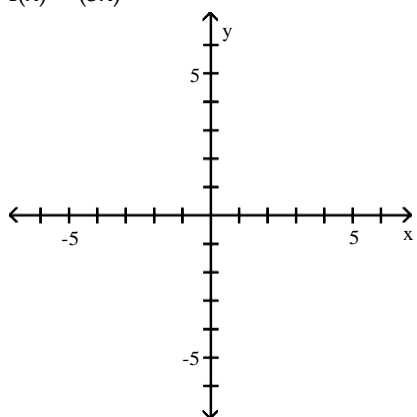

A)

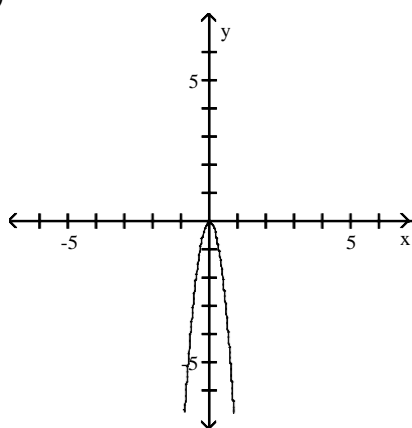

B)

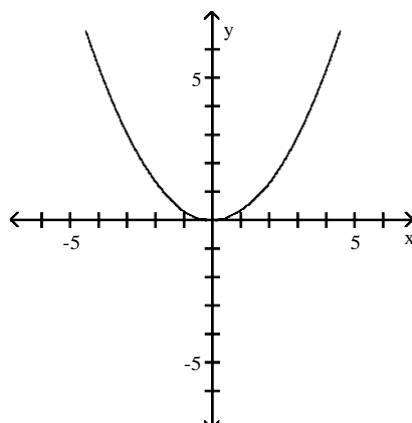

C)

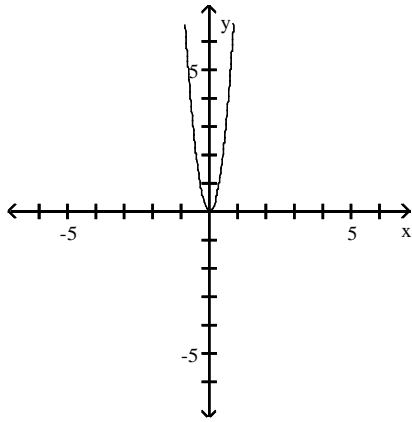

D)

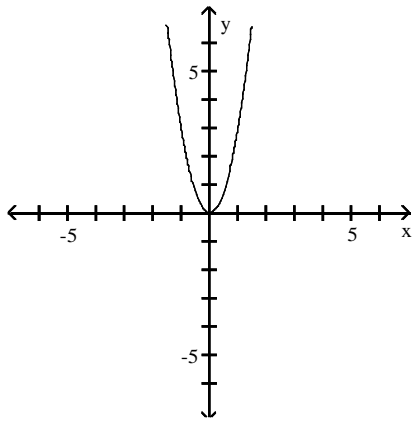

Answer: C

394) $f(x) = |3x|$

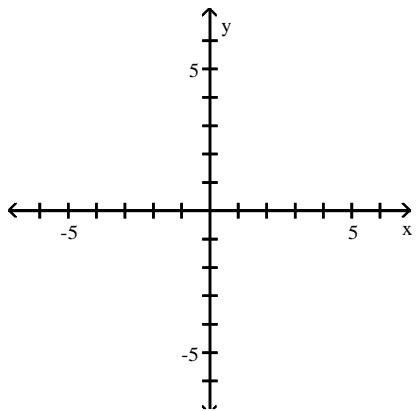

A)

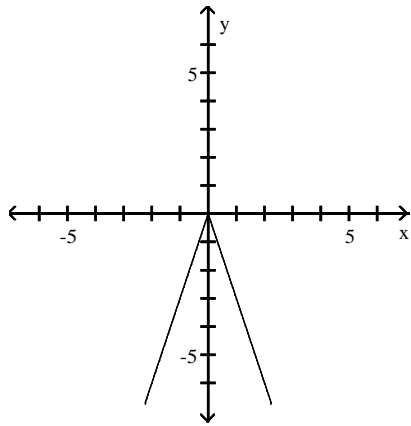

B)

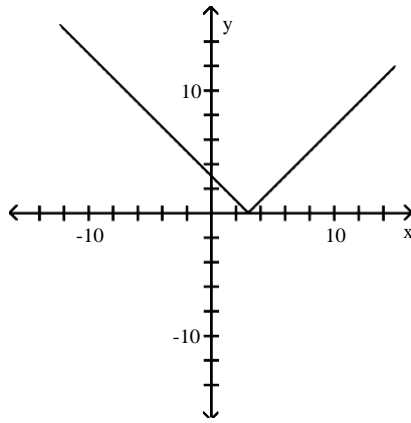

C)

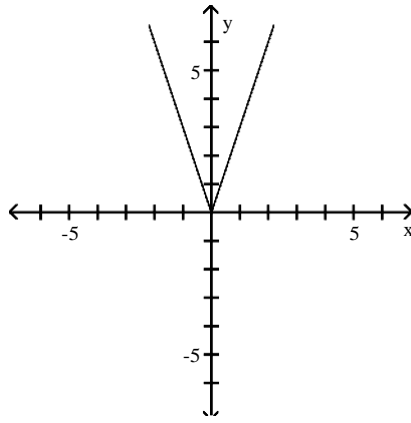

D)

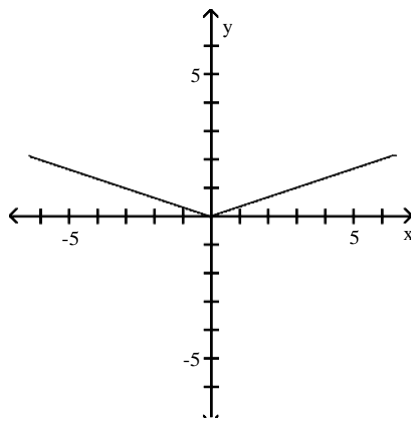

Answer: C

395) $y = -3|x|$

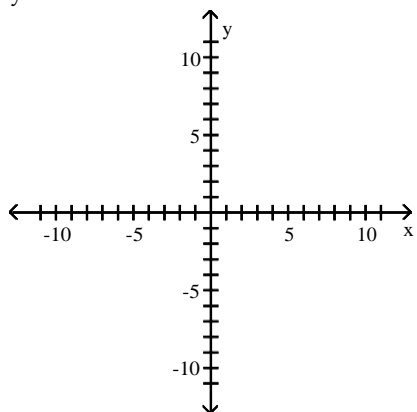

A)

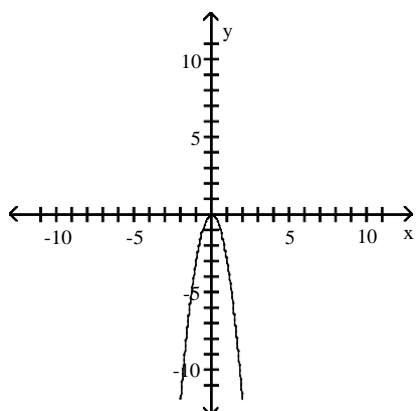

B)

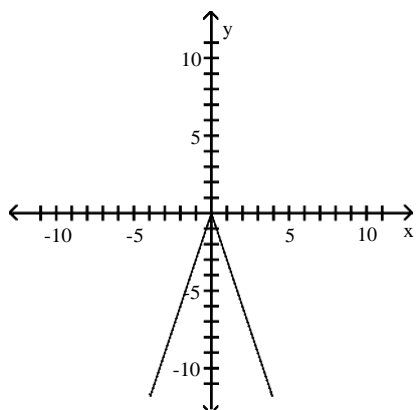

C)

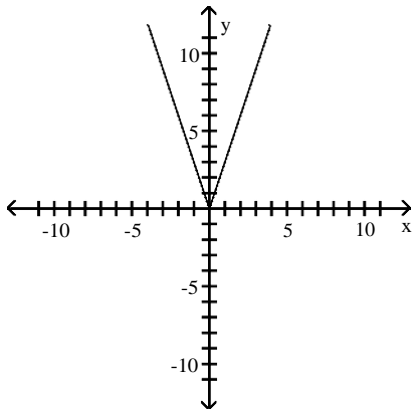

D)

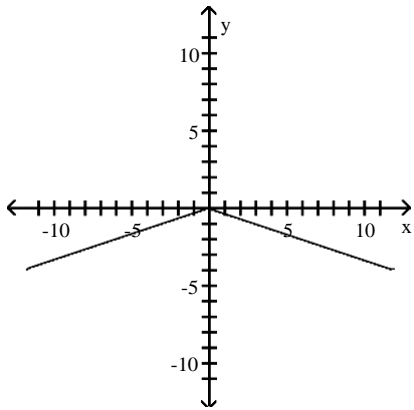

Answer: B

396) $f(x) = -\frac{1}{7}x^2$

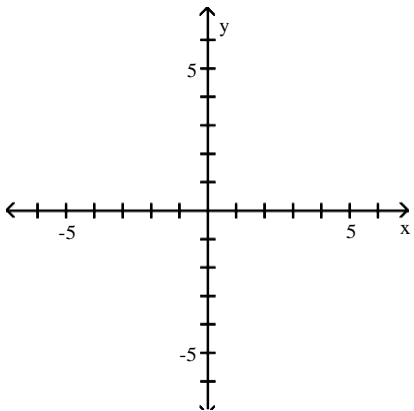

A)

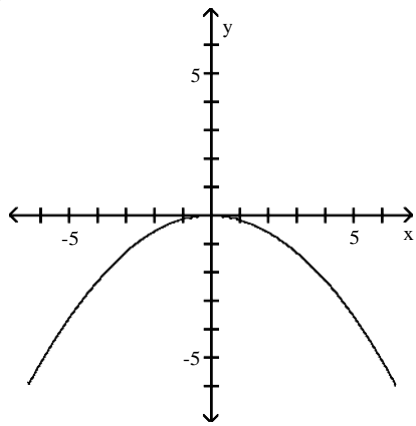

B)

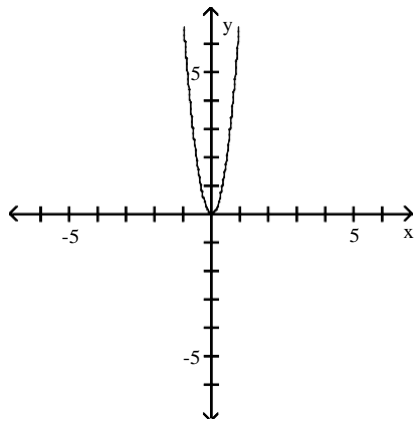

C)

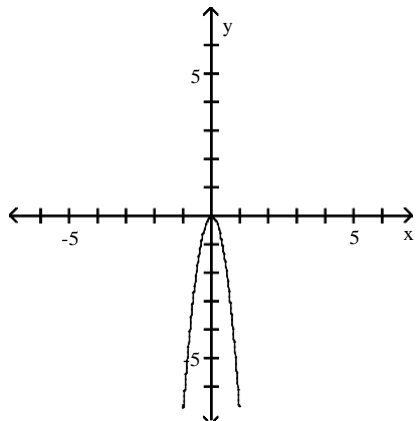

D)

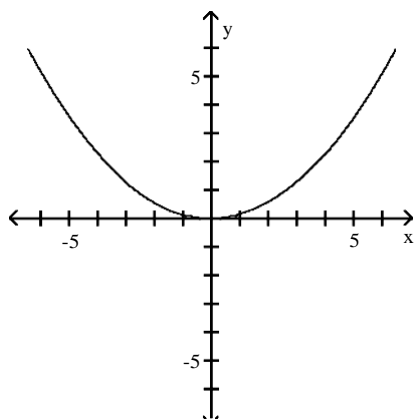

Answer: A

397) $f(x) = 3(-x)^3$

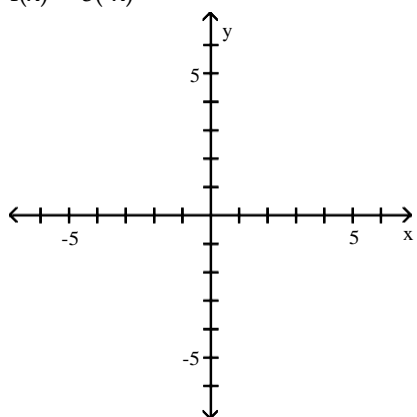

A)

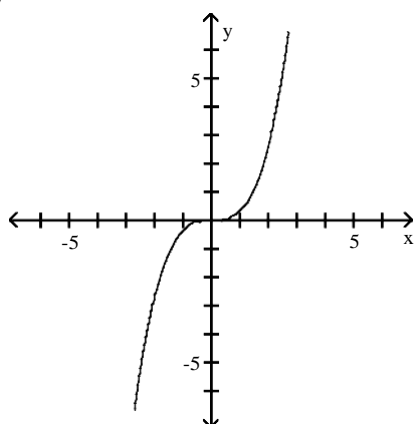

B)

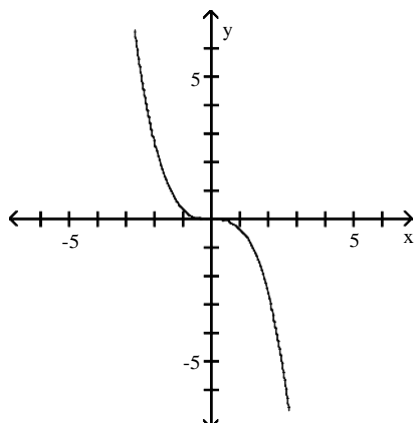

C)

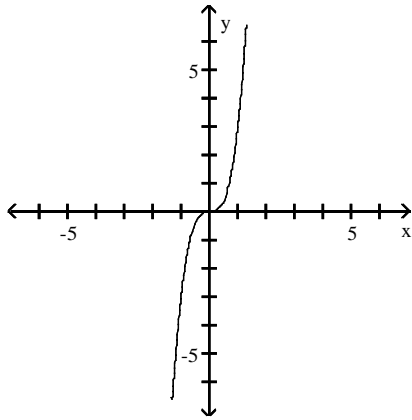

D)

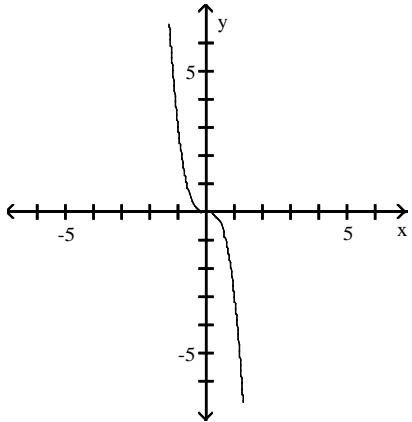

Answer: D

398) $f(x) = \frac{1}{2}\sqrt{-x}$

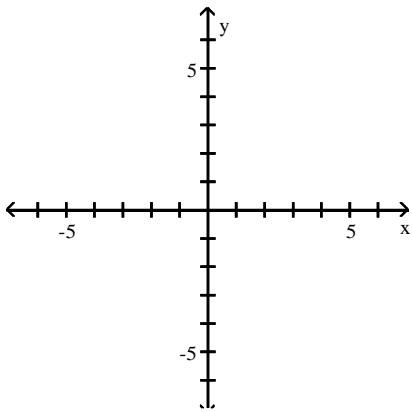

A)

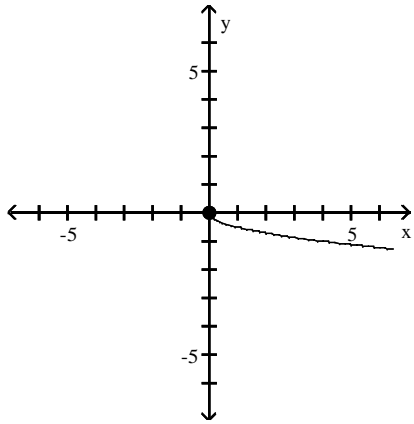

B)

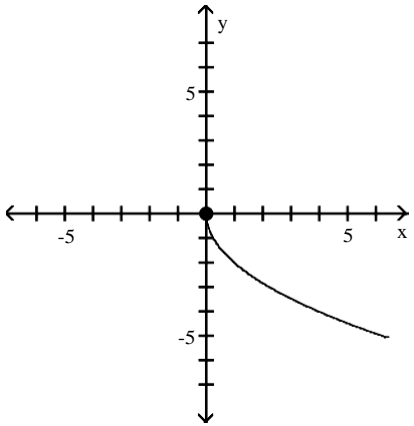

C)

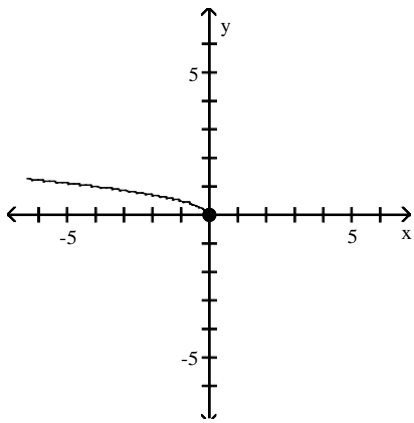

D)

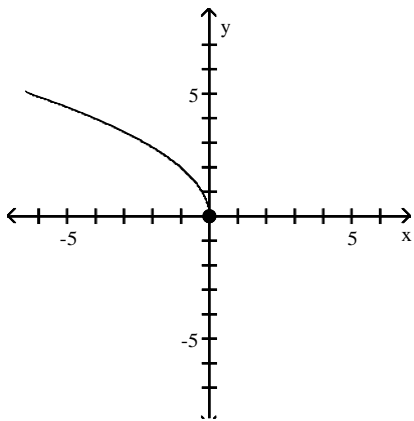

Answer: C

399) $f(x) = \frac{1}{5} |-x|$

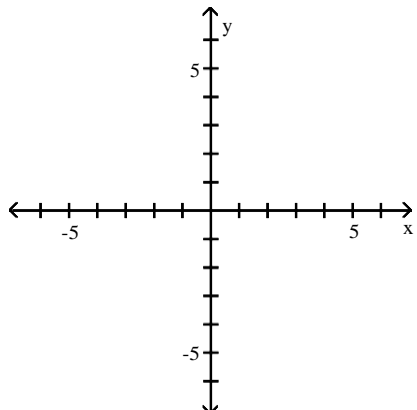

A)

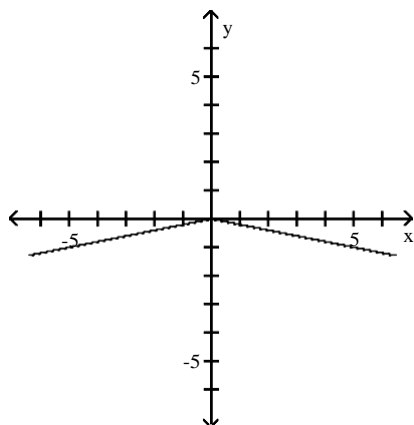

B)

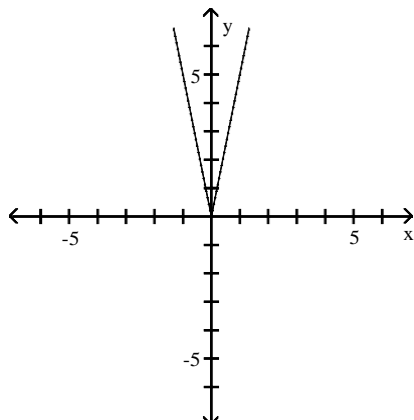

C)

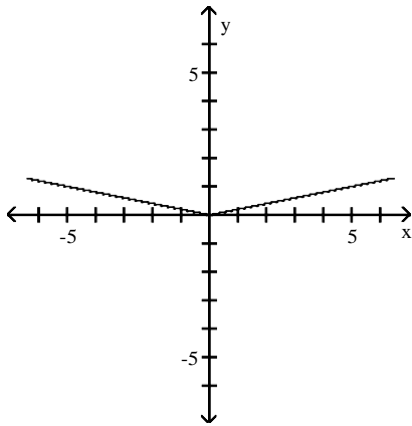

D)

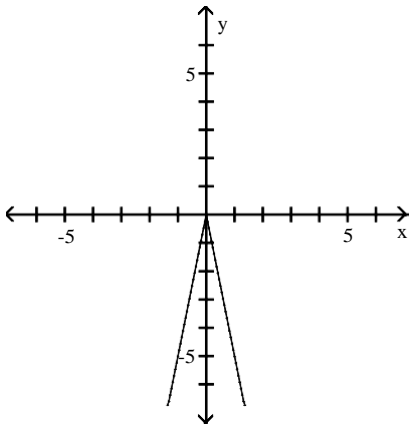

Answer: C

400) $y = x^2 + 2$

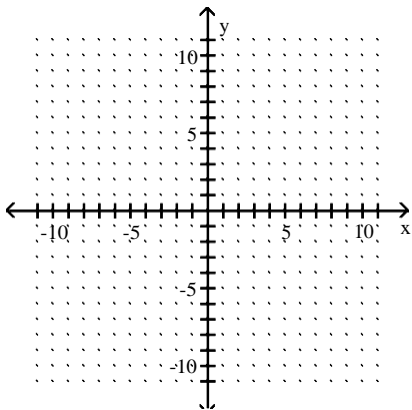

A)

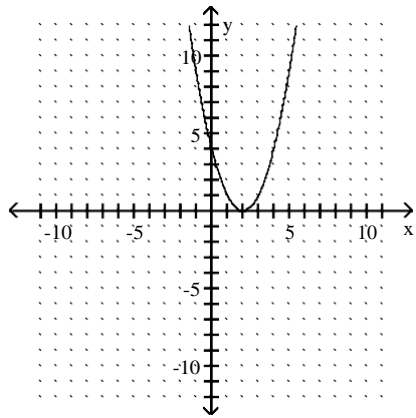

B)

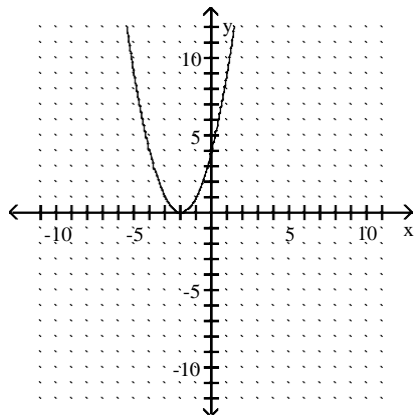

C)

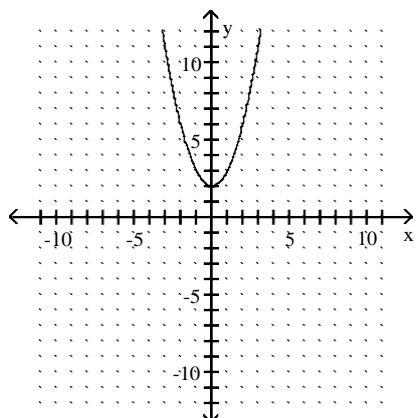

D)

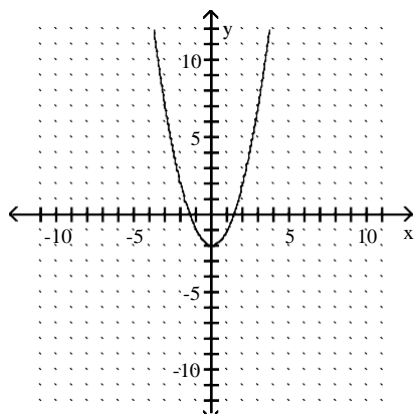

Answer: C

401) $f(x) = (x - 5)^2$

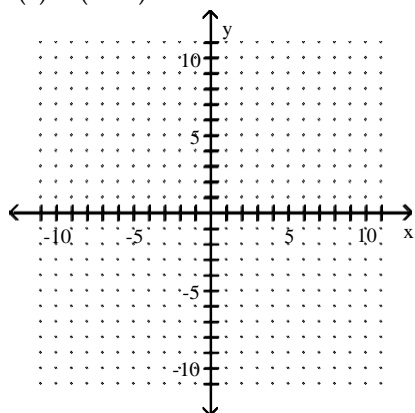

A)

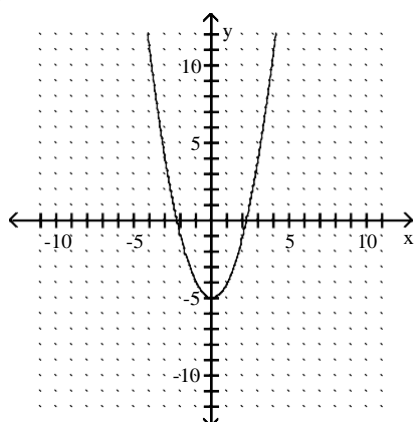

B)

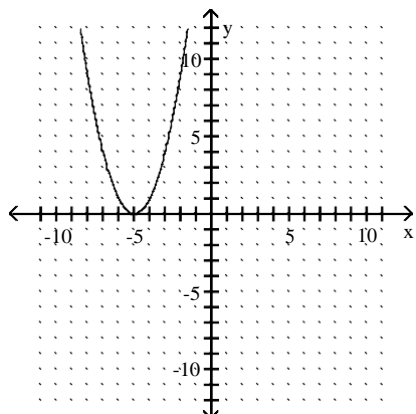

C)

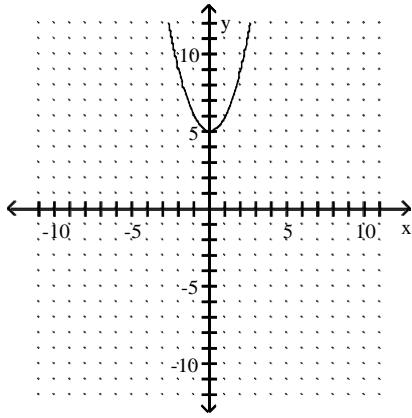

D)

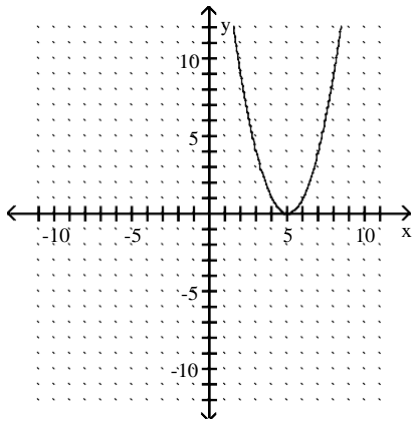

Answer: D

402) $y = (x - 7)^2 + 3$

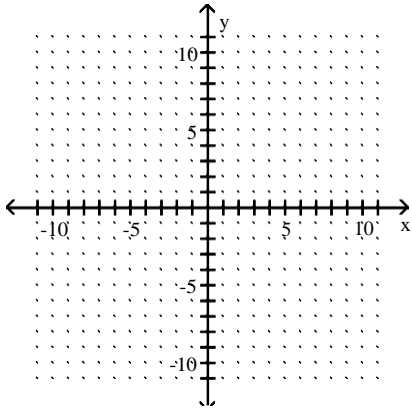

A)

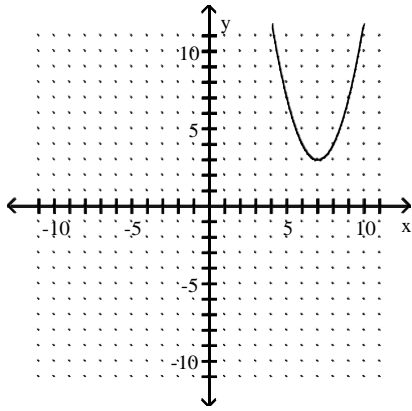

B)

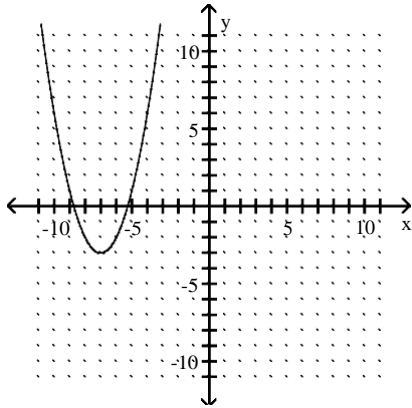

C)

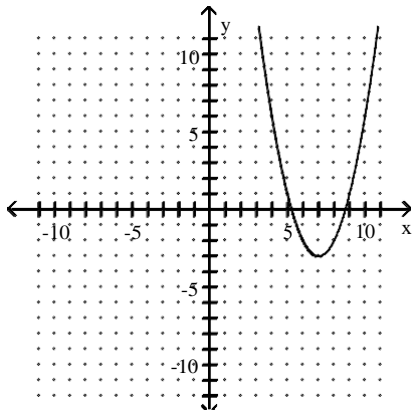

D)

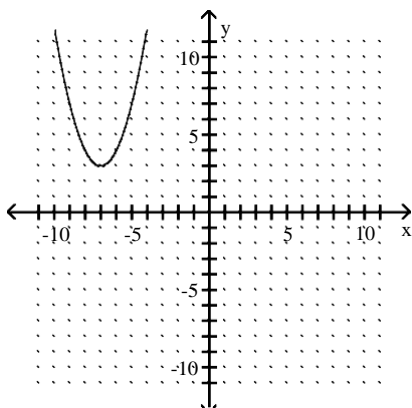

Answer: A

403) $f(x) = x^3 + 2$

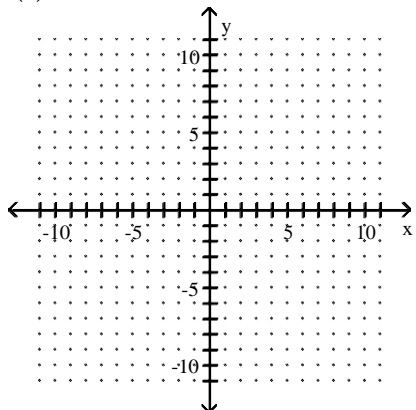

A)

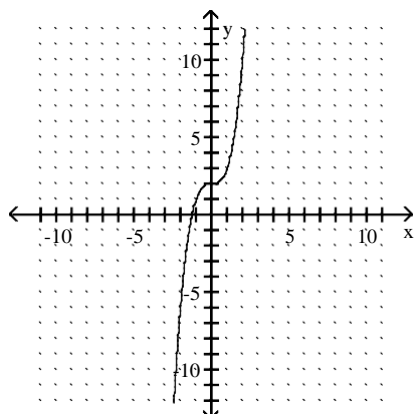

B)

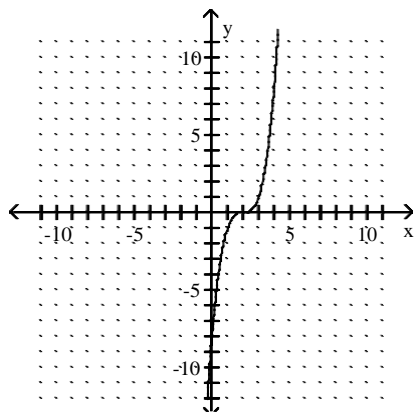

C)

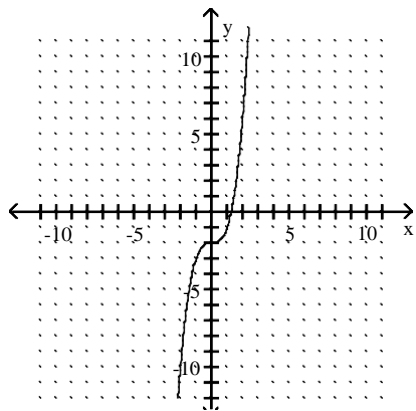

D)

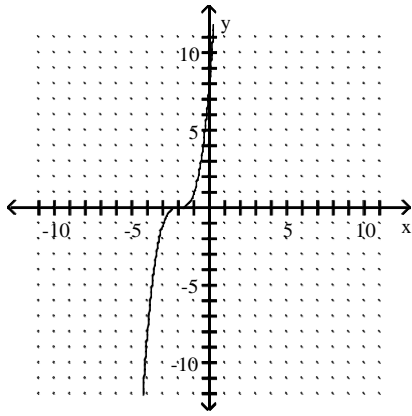

Answer: A

404) $y = (x - 1)^3$

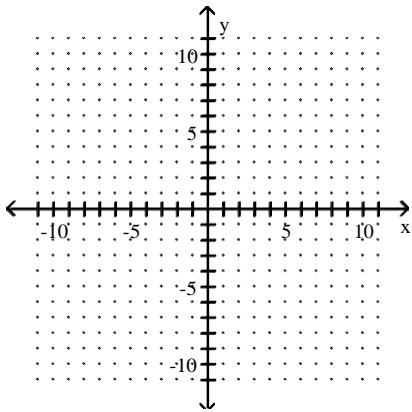

A)

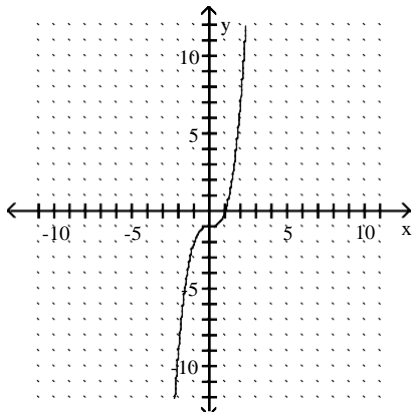

B)

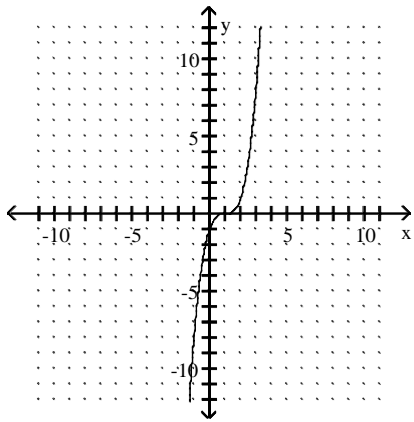

C)

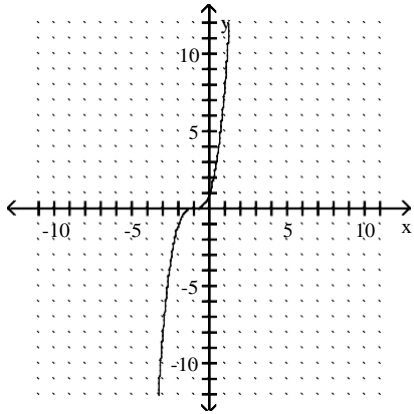

D)

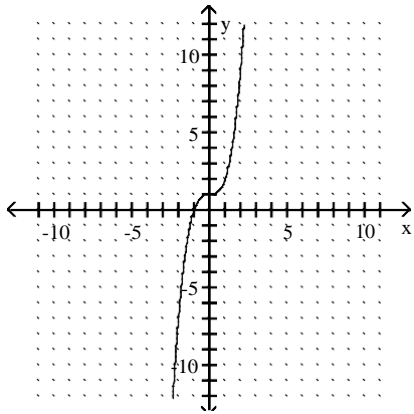

Answer: B

405) $f(x) = (x + 1)^3 + 7$

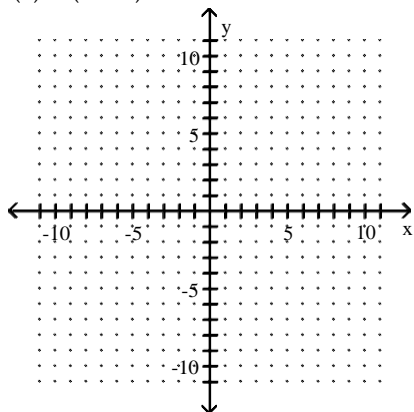

A)

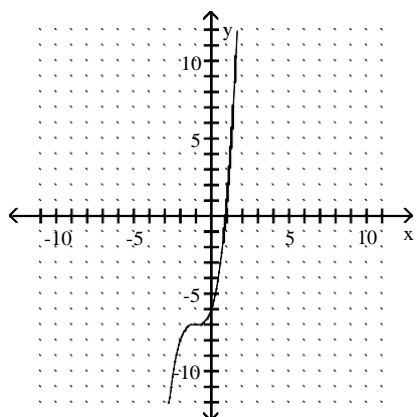

B)

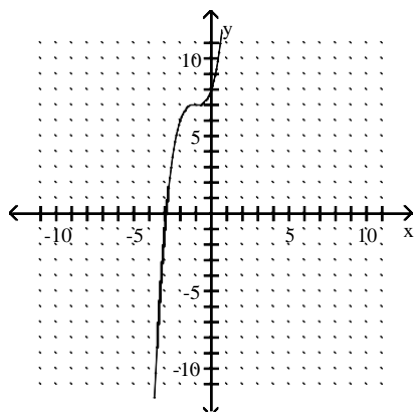

C)

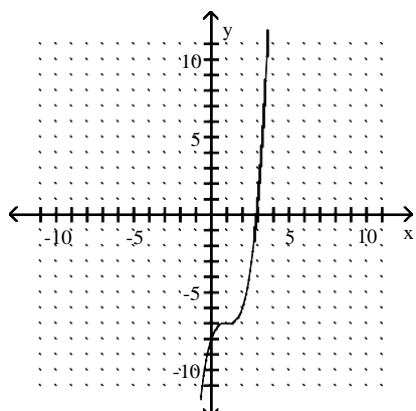

D)

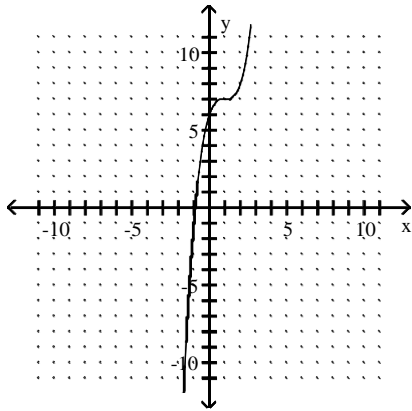

Answer: B

406) $y = \sqrt{x+5}$

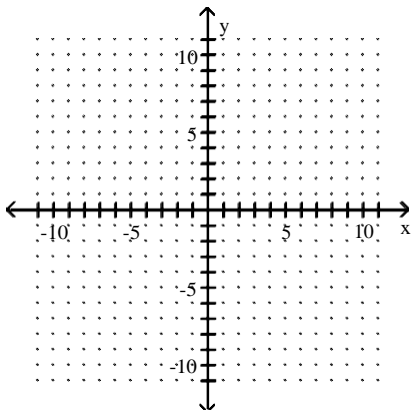

A)

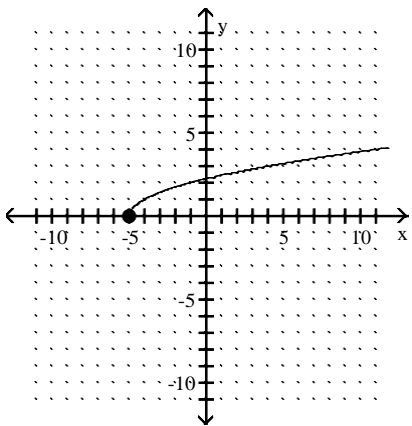

B)

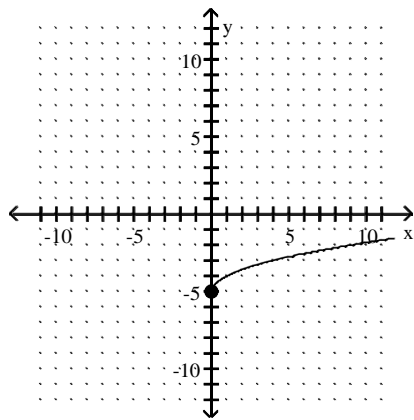

C)

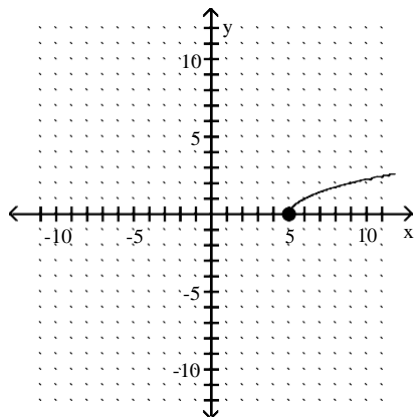

D)

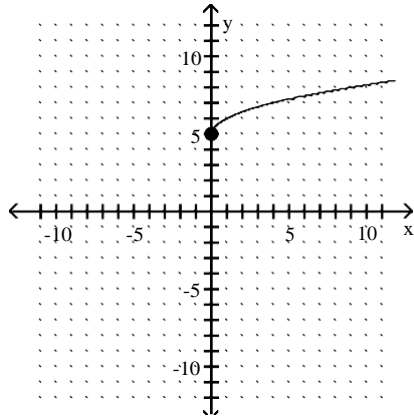

Answer: A

407) $y = \sqrt{x+7} - 1$

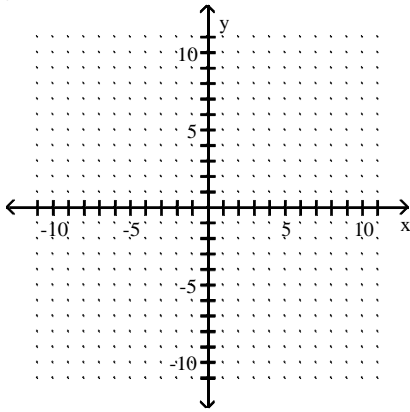

A)

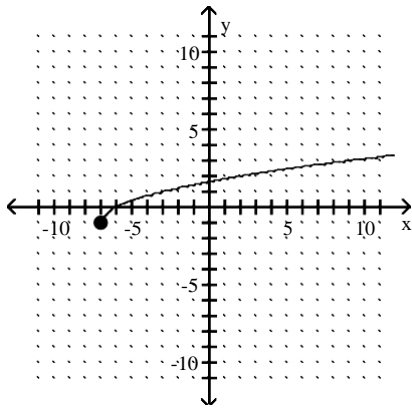

B)

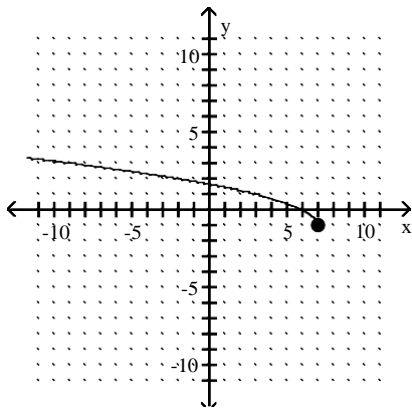

C)

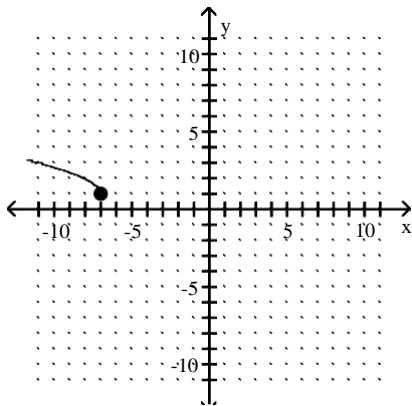

D)

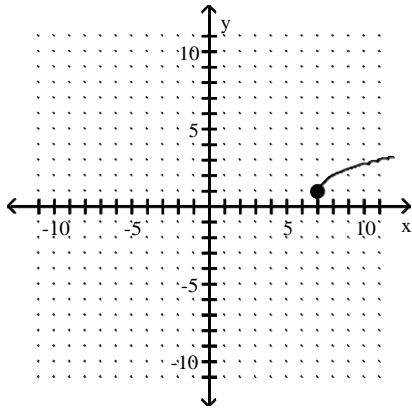

Answer: A

408) $f(x) = |x| + 5$

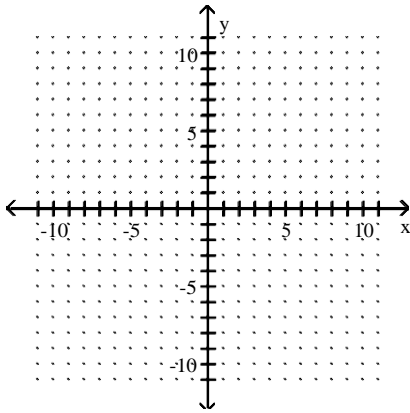

A)

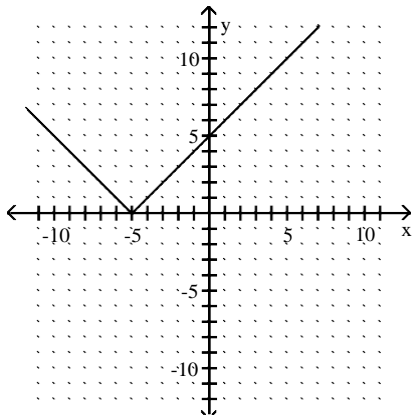

B)

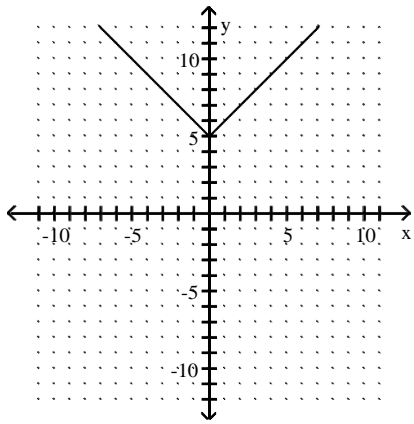

C)

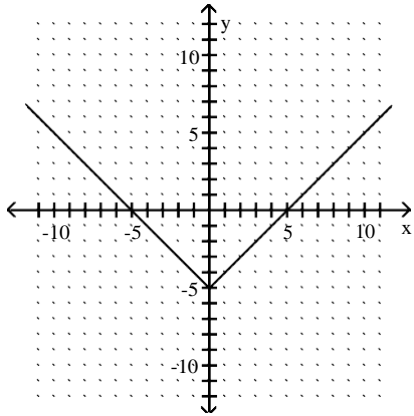

D)

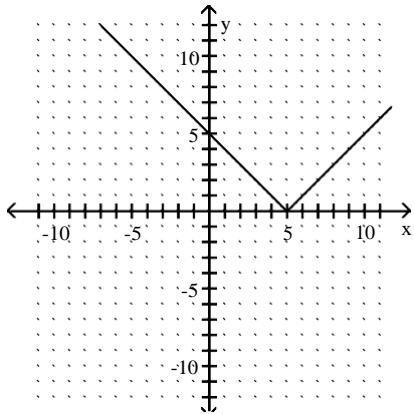

Answer: B

409) $y = |x - 5| - 5$

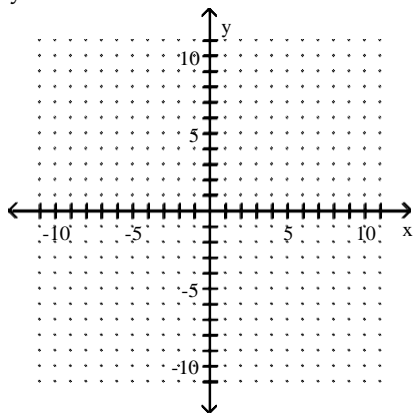

A)

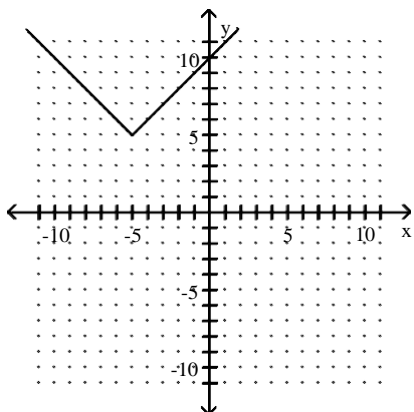

B)

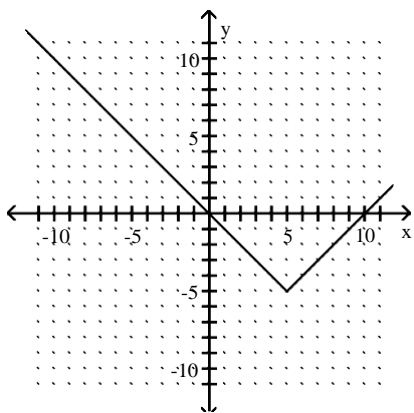

C)

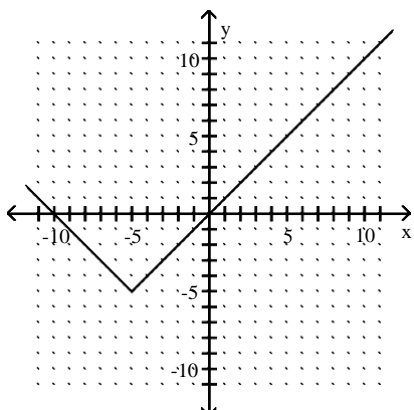

D)

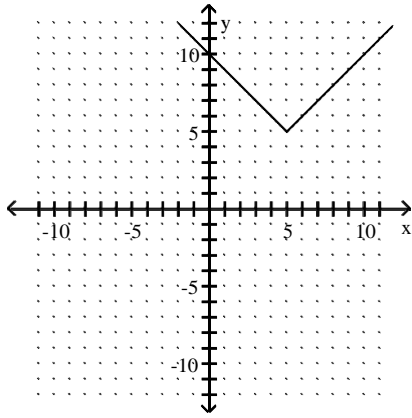

Answer: B

$$410) y = \frac{1}{3}(x + 2)^2$$

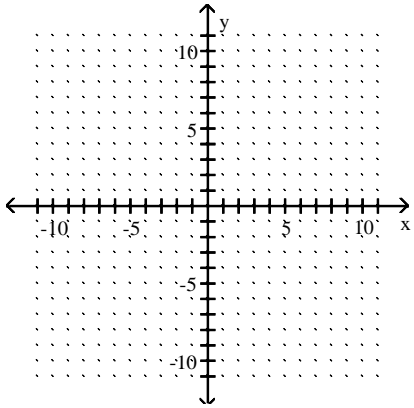

A)

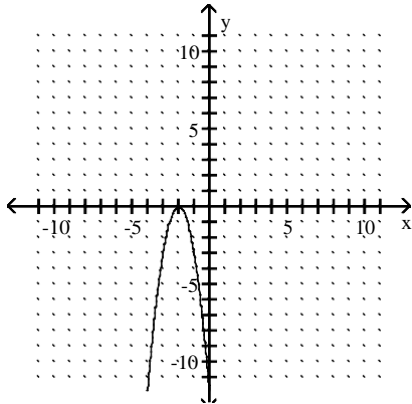

B)

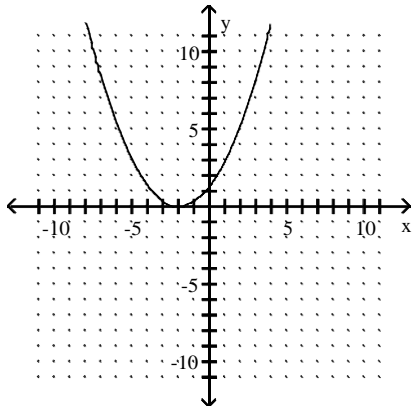

C)

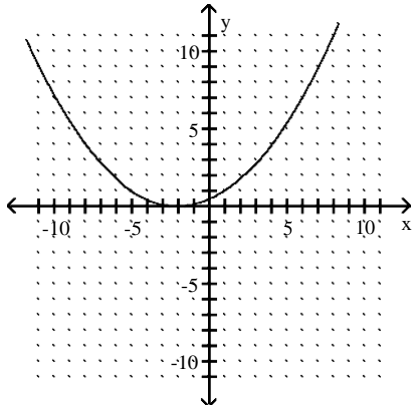

D)

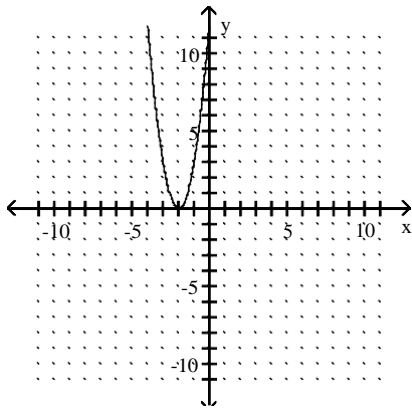

Answer: B

411) $f(x) = 2(x + 1)^2 - 4$

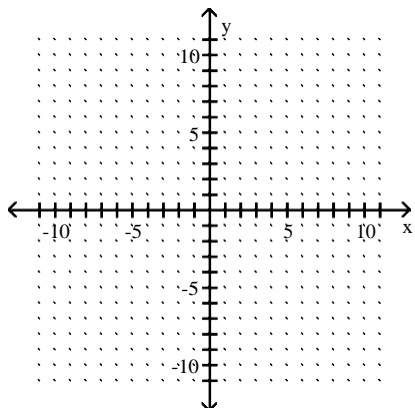

A)

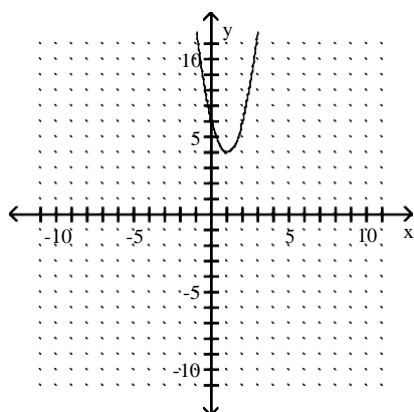

B)

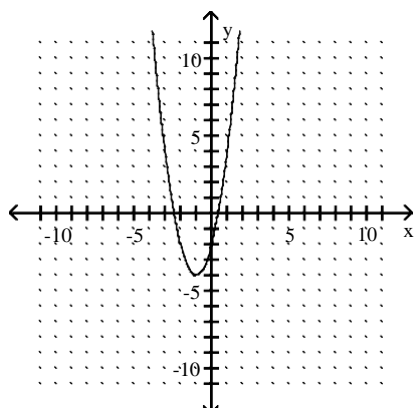

C)

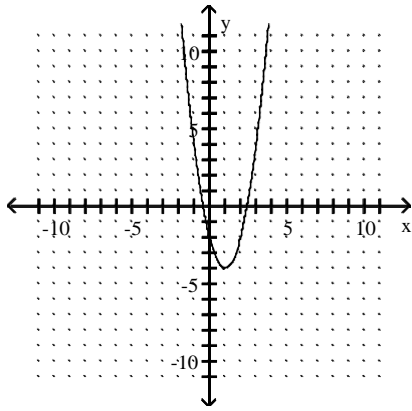

D)

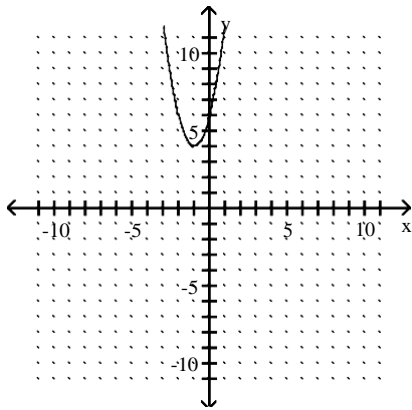

Answer: B

$$412) y = \frac{1}{3}(x + 5)^3 + 4$$

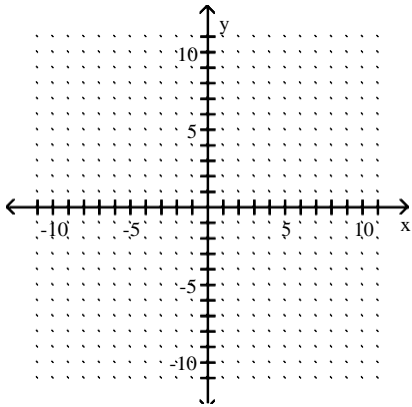

A)

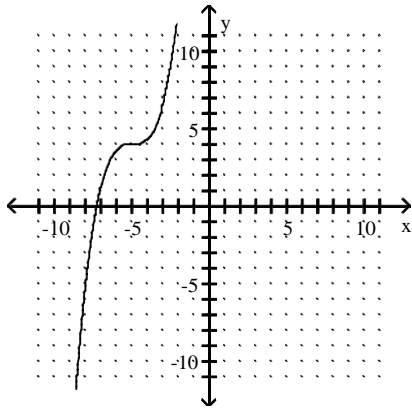

B)

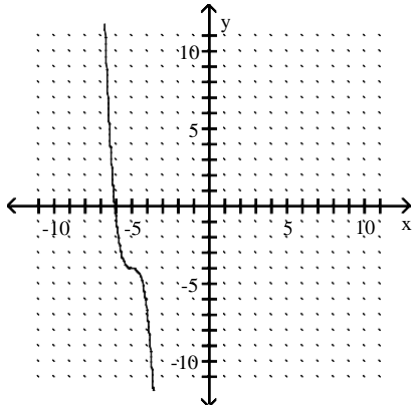

C)

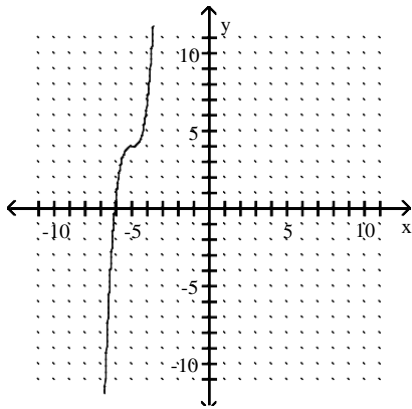

D)

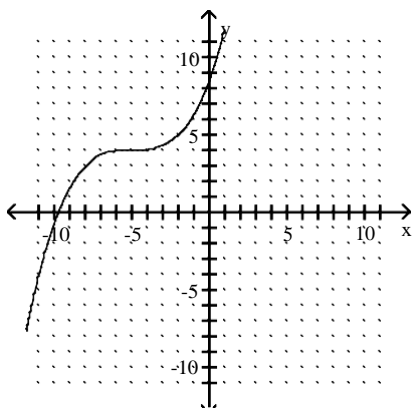

Answer: A

413) $f(x) = -(x + 2)^2 + 5$

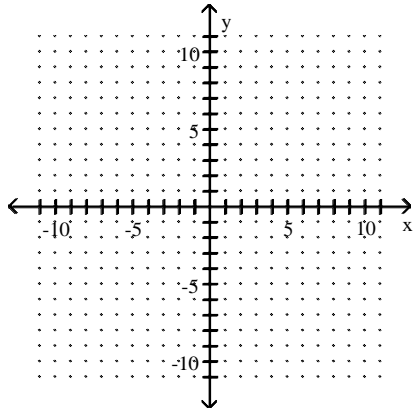

A)

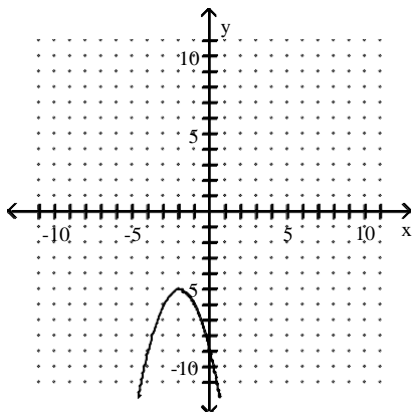

B)

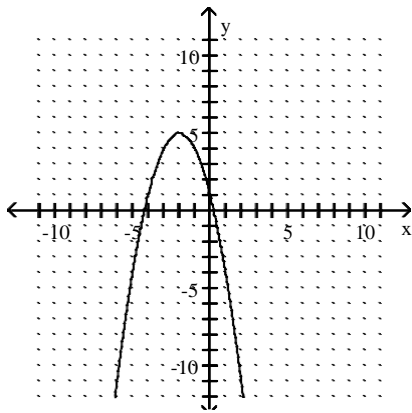

C)

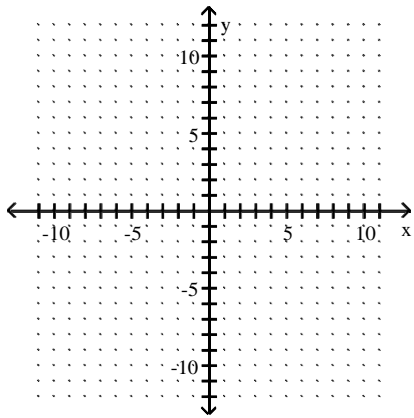

D)

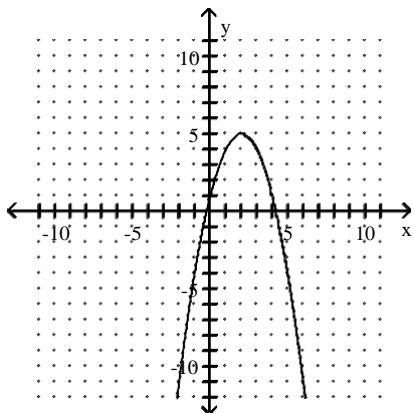

Answer: B

414) $y = 2x^2 - 6$

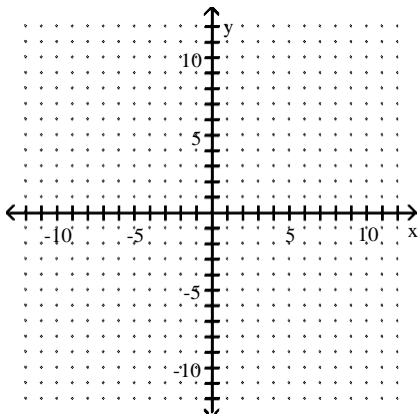

A)

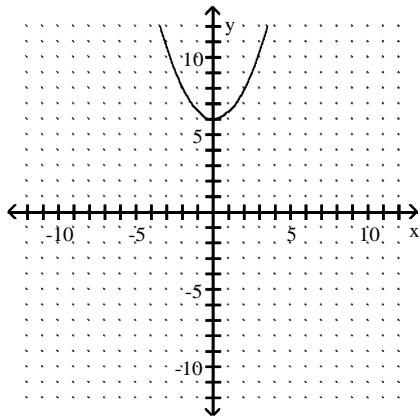

B)

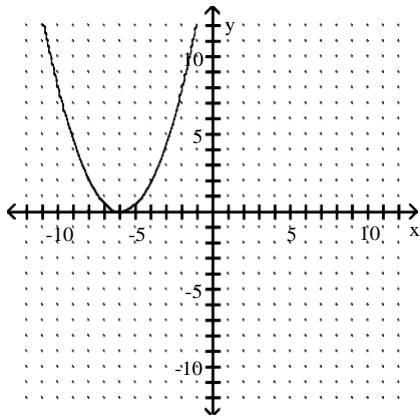

C)

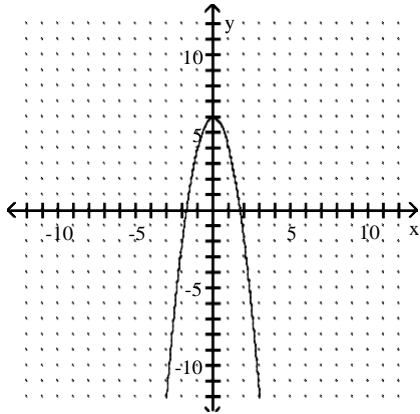

D)

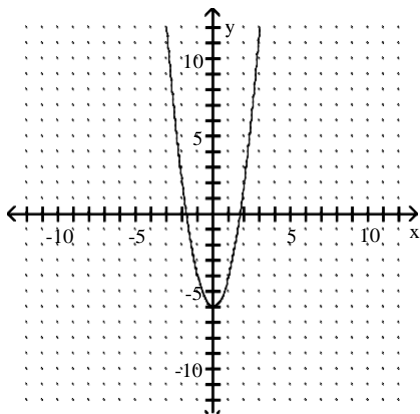

Answer: D

415) $y = 2|x| - 7$

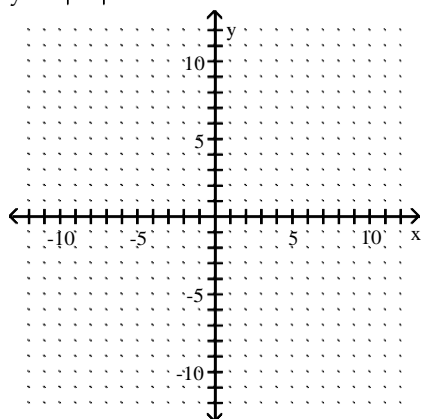

A)

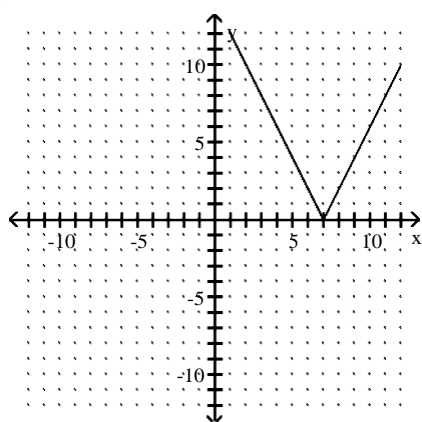

B)

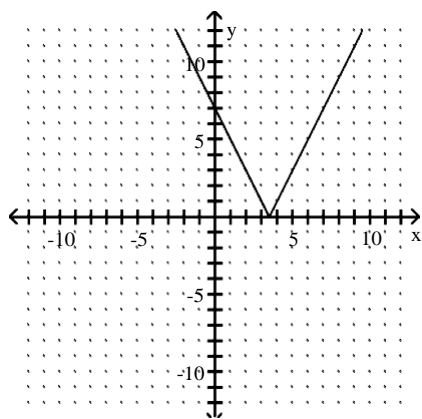

C)

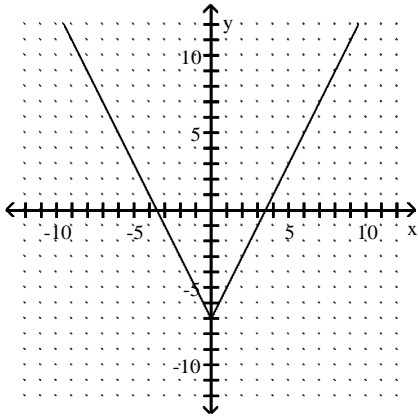

D)

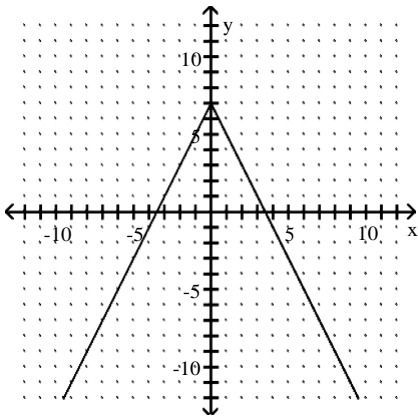

Answer: C

416) $g(x) = -\sqrt{x+2} - 2$

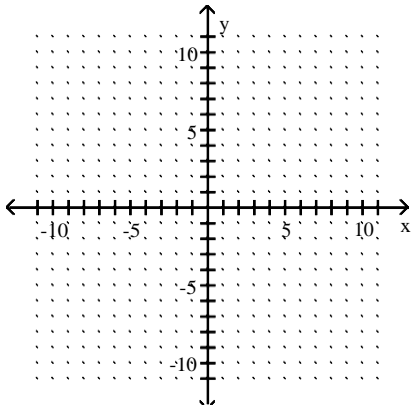

A)

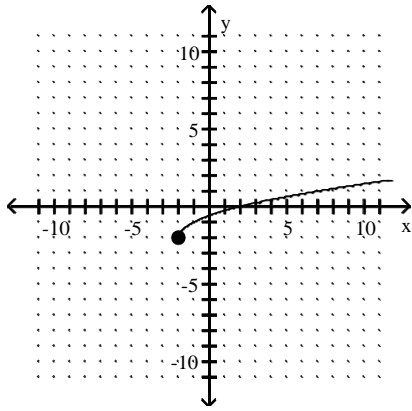

B)

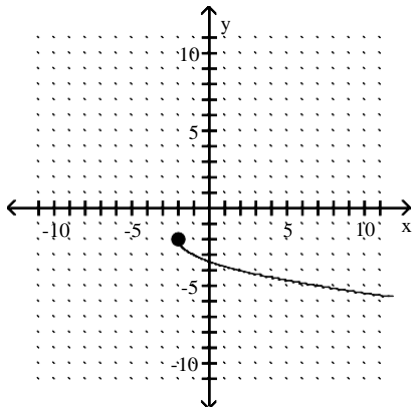

C)

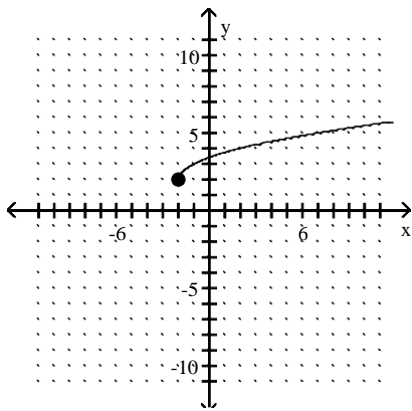

D)

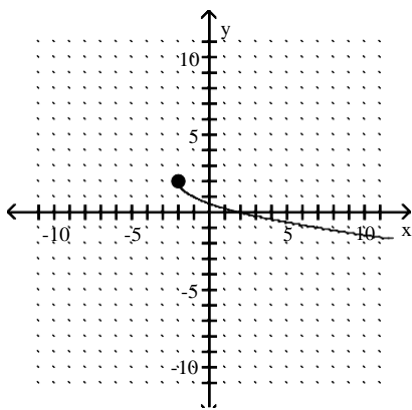

Answer: B

417) $h(x) = \sqrt{-x + 1} + 2$

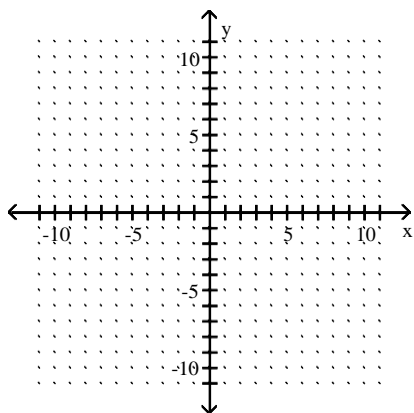

A)

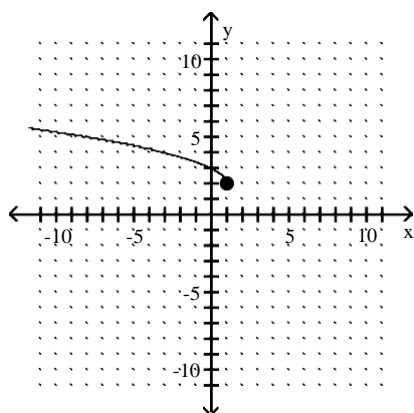

B)

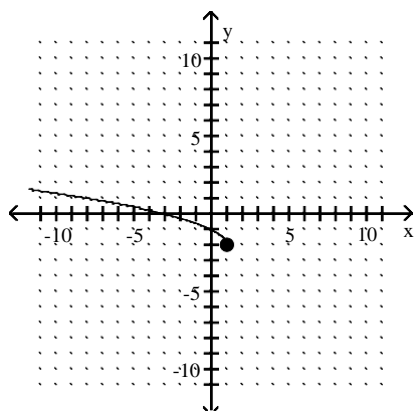

C)

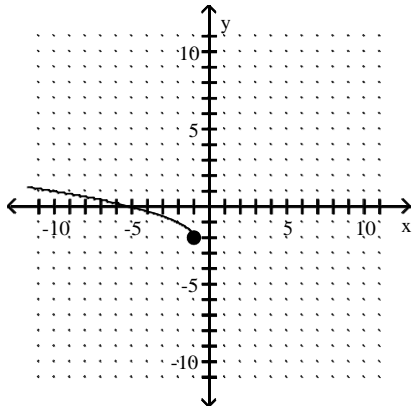

D)

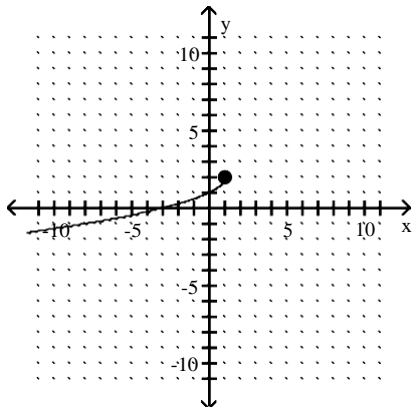

Answer: A

$$418) g(x) = \frac{1}{4}|x + 5| + 6$$

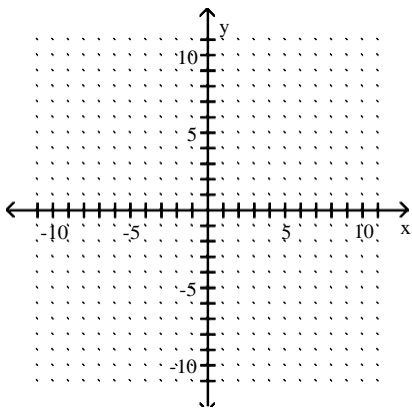

A)

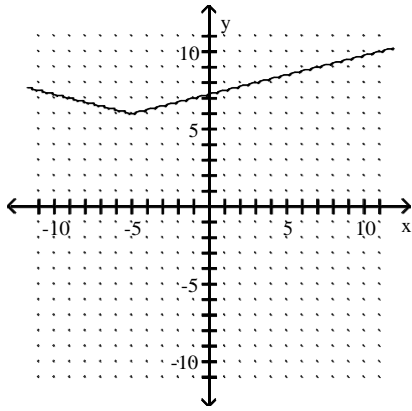

B)

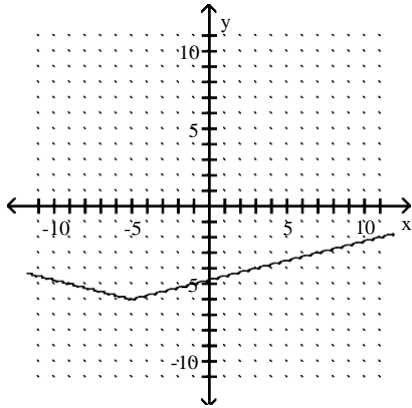

C)

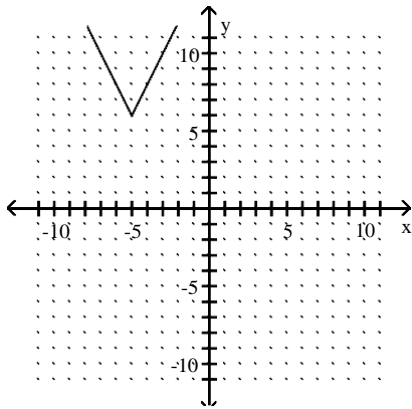

D)

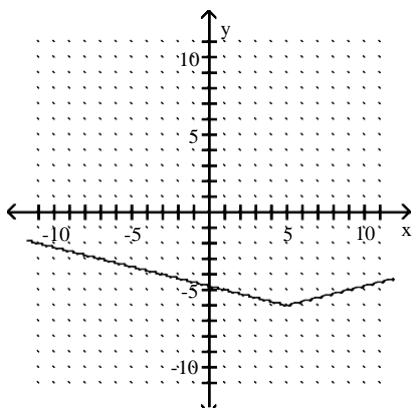

Answer: A

419) $g(x) = -(x + 2)^3 + 4$

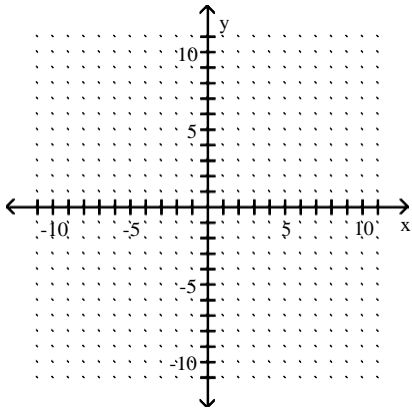

A)

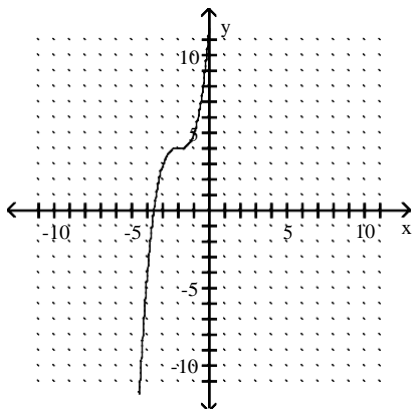

B)

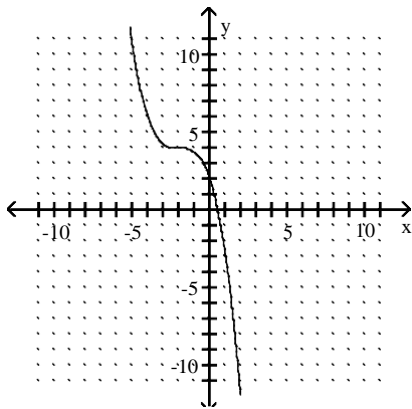

C)

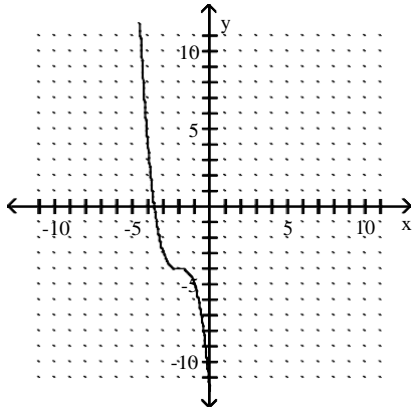

D)

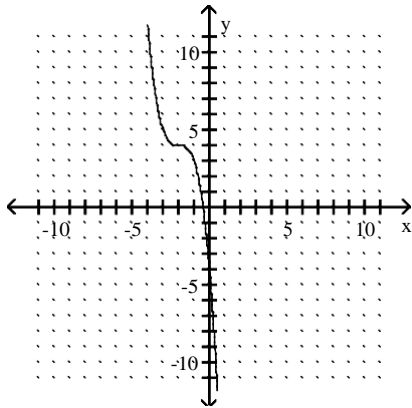

Answer: D

Suppose the point $(2, 4)$ is on the graph of $y = f(x)$. Find a point on the graph of the given function.

420) $y = f(x + 5)$

- A) $(2, 9)$
- B) $(-3, 4)$
- C) $(7, 4)$
- D) $(2, -1)$

Answer: B

421) $y = f(x) + 4$

- A) $(2, 8)$
- B) $(-2, 4)$
- C) $(2, -4)$
- D) $(6, 4)$

Answer: A

422) $y = 2f(x)$

- A) $(4, 4)$
- B) $(5, 1)$
- C) $(2, 8)$
- D) $(1, 4)$

Answer: C

423) The reflection of the graph of $y = f(x)$ across the x -axis

- A) $(-2, 4)$
- B) $(-2, -4)$
- C) $(2, -4)$
- D) $(2, 4)$

Answer: C

424) The reflection of the graph of $y = f(x)$ across the y -axis

- A) $(-2, -4)$
- B) $(2, -4)$
- C) $(-2, 4)$
- D) $(2, 4)$

Answer: C

The figure below shows the graph of a function $y = f(x)$. Use this graph to solve the problem.

425) Sketch the graph of $y = -f(x)$.

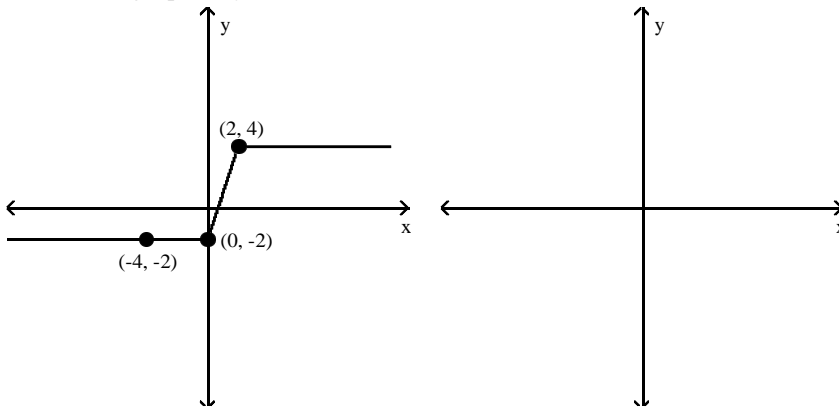

A)

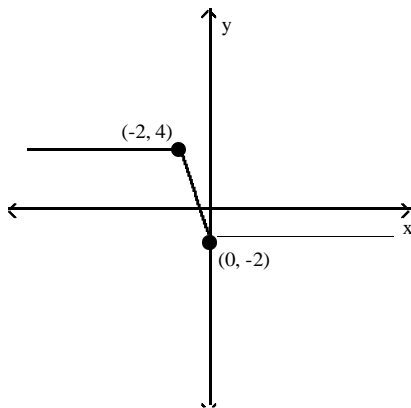

B)

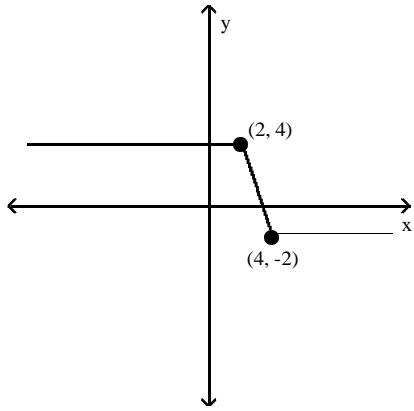

C)

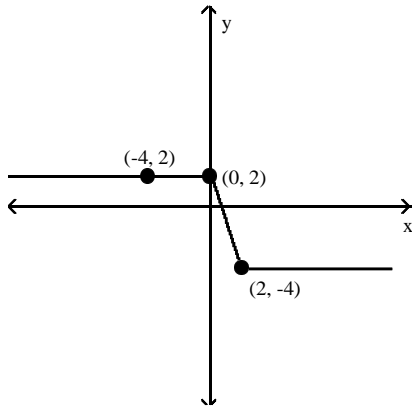

D)

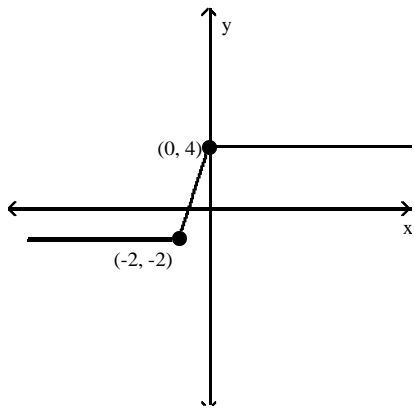

Answer: C

426) Sketch the graph of $y = f(-x)$.

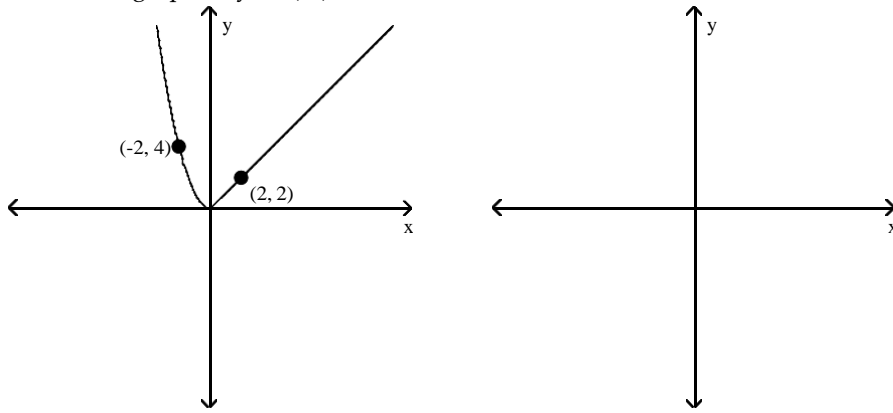

A)

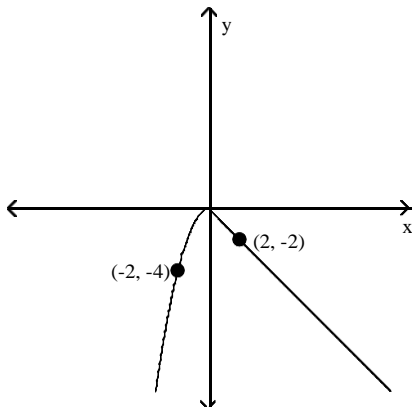

B)

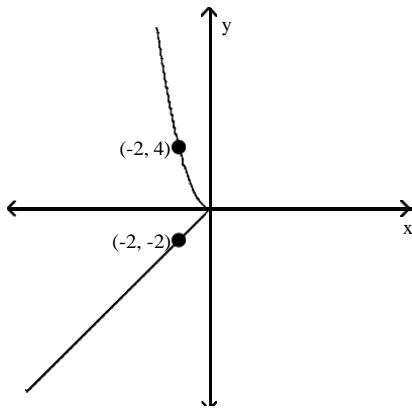

C)

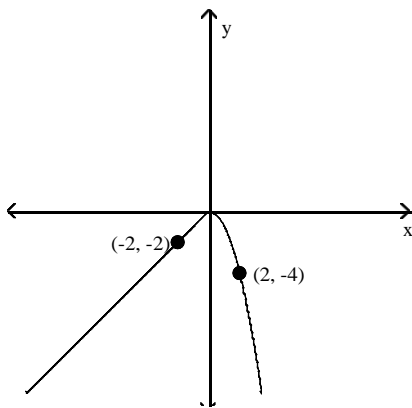

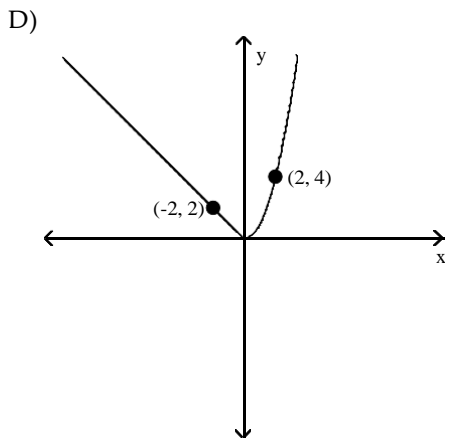

Answer: D

427) Sketch the graph of $y = f(-x)$.

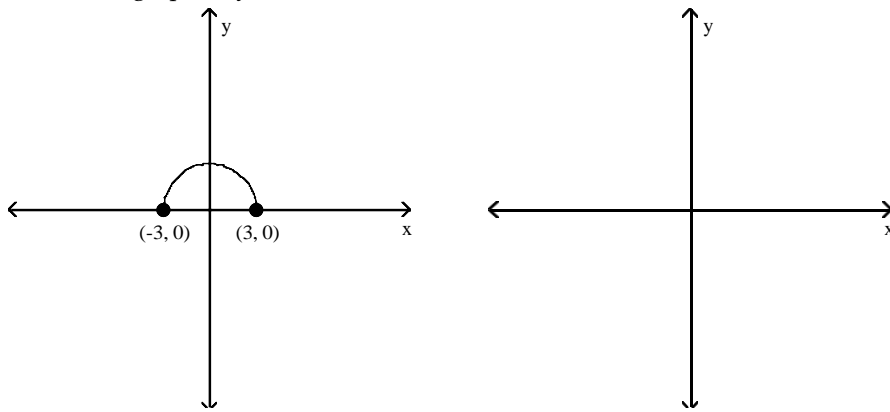

A)

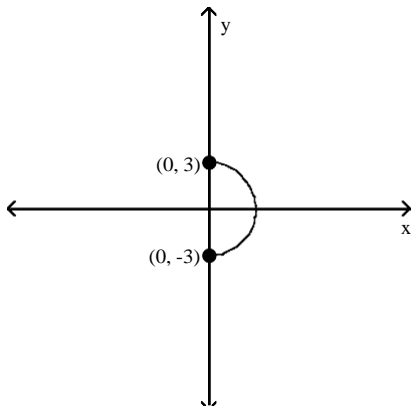

B)

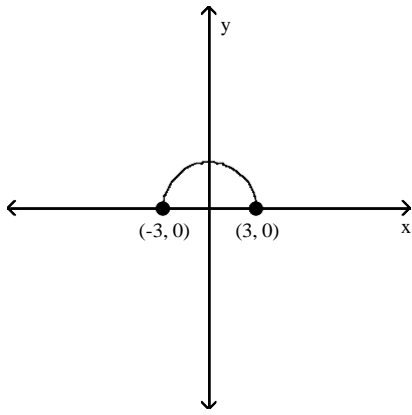

C)

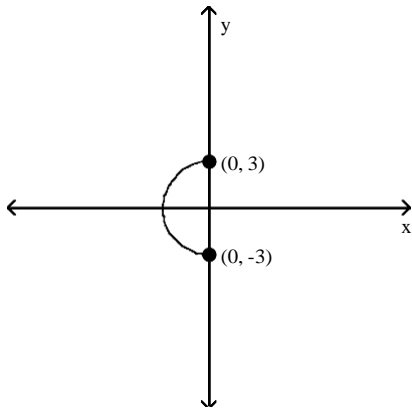

D)

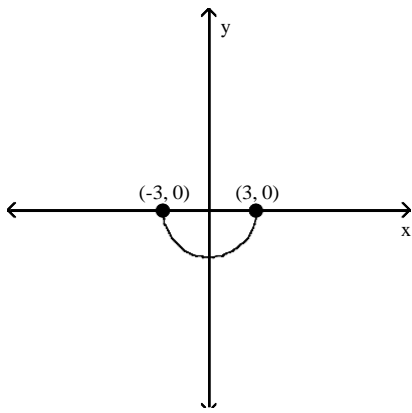

Answer: B

428) Sketch the graph of $y = -f(x)$.

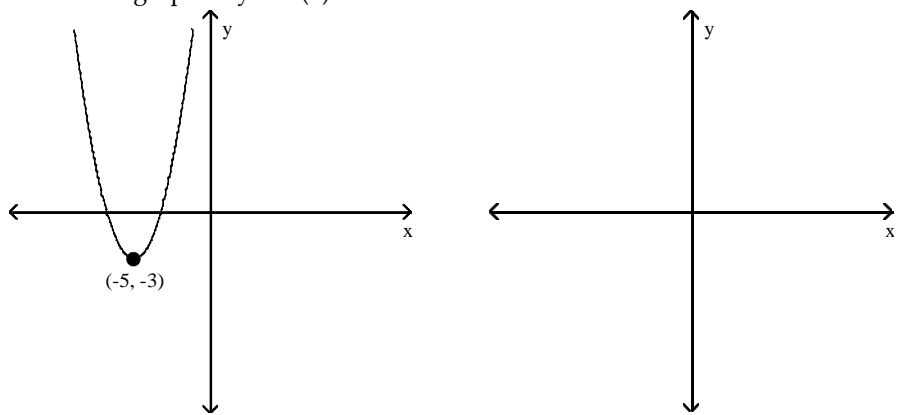

A)

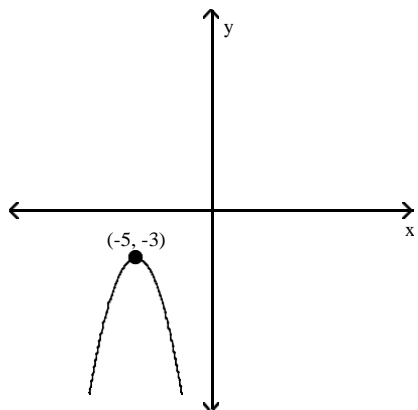

B)

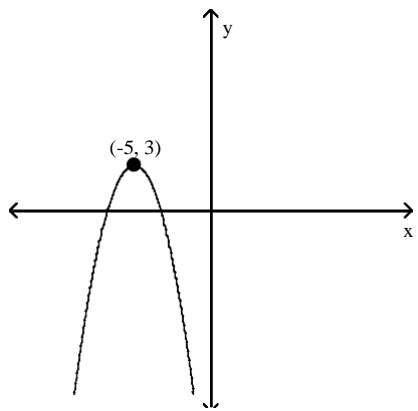

C)

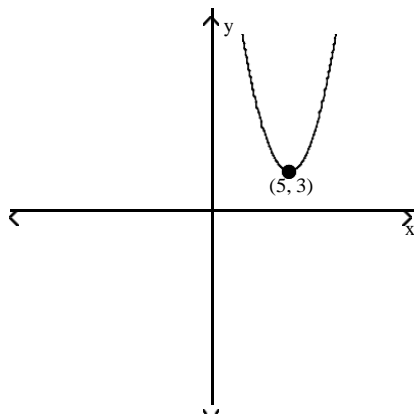

D)

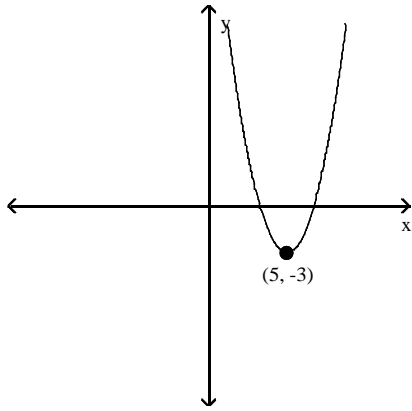

Answer: B

429) Sketch the graph of $y = 2f(x)$.

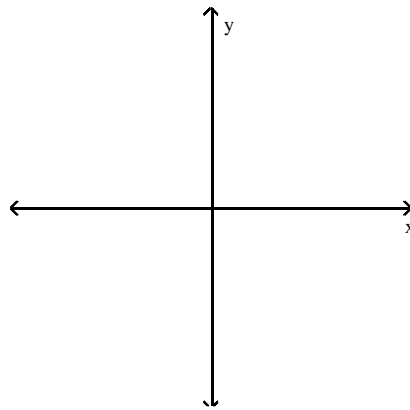
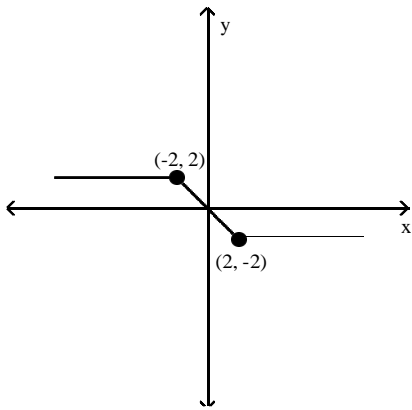

A)

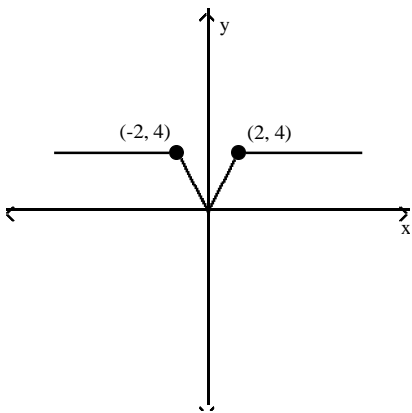

B)

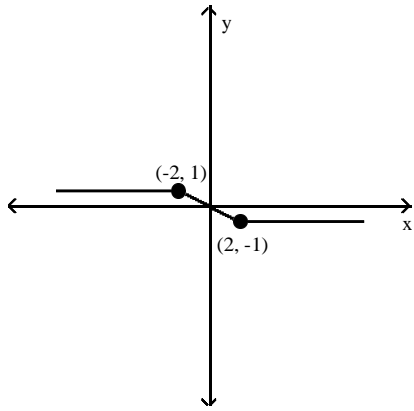

C)

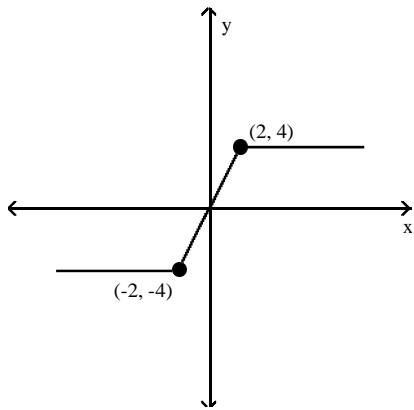

D)

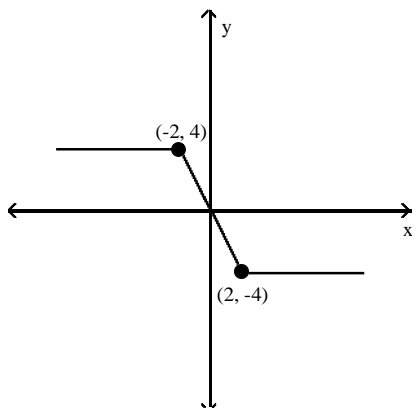

Answer: D

430) Sketch the graph of $y = -\frac{1}{2}f(x)$.

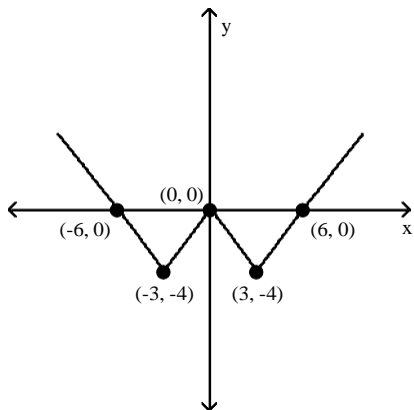

A)

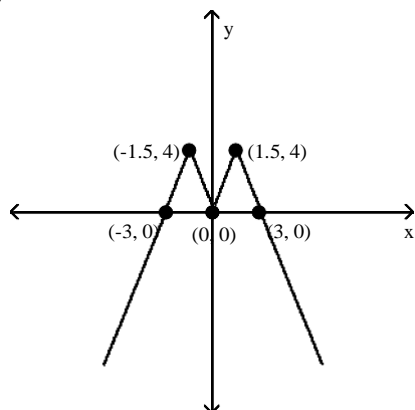
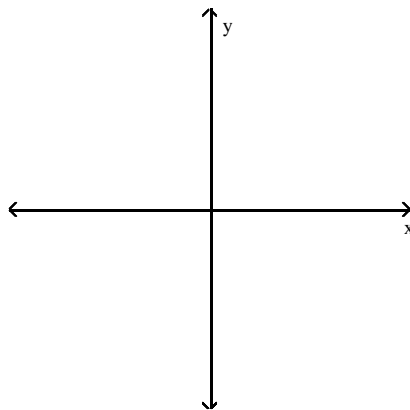

B)

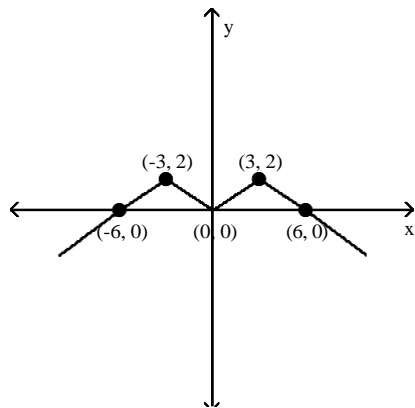

C)

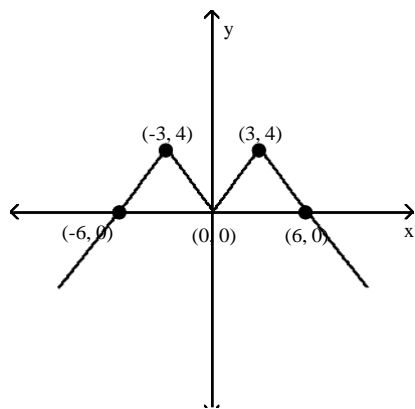

D)

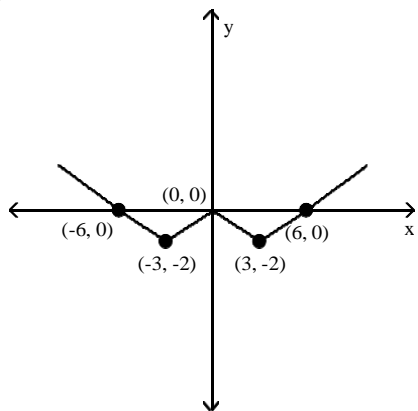

Answer: B

431) Sketch the graph of $y = f(x - 3)$.

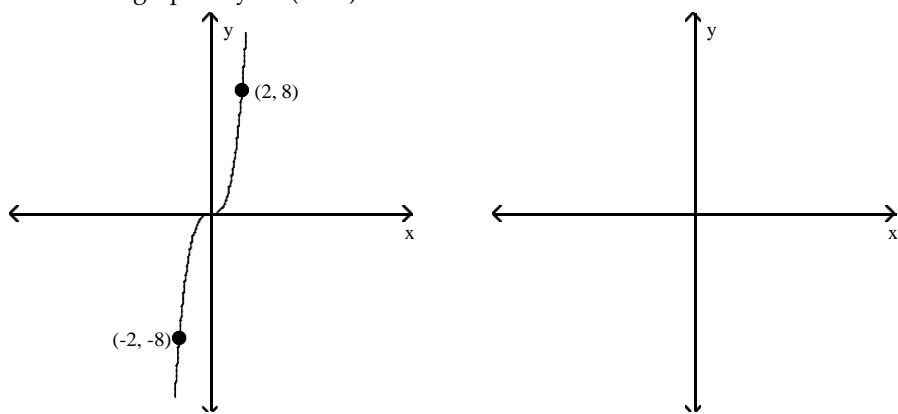

A)

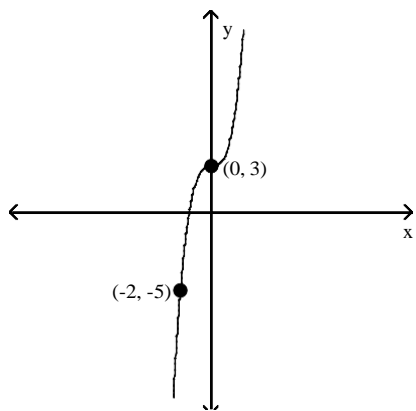

B)

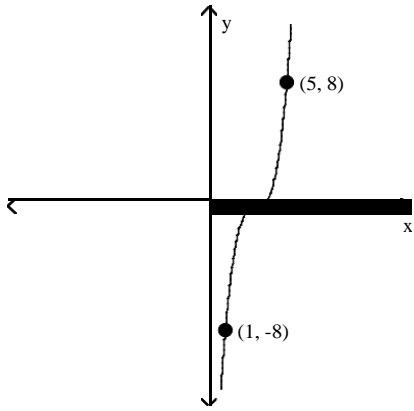

C)

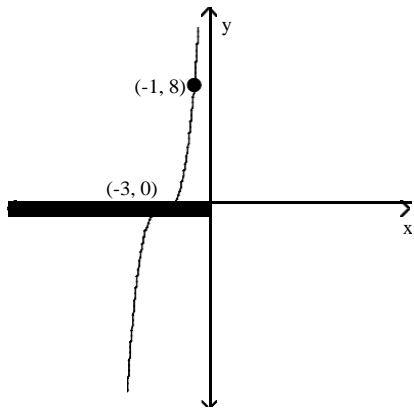

D)

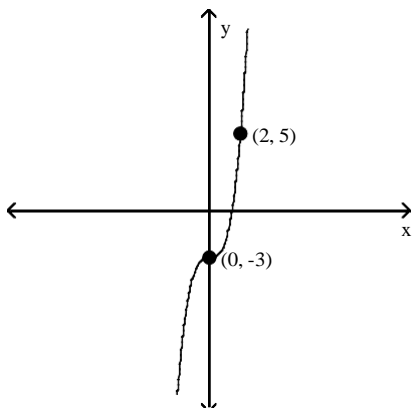

Answer: B

Graph the point symmetric to the given point.

432) Plot the point $(3, 4)$, then plot the point that is symmetric to $(3, 4)$ with respect to the x -axis.

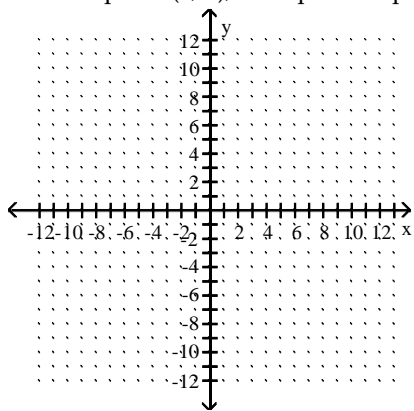

A)

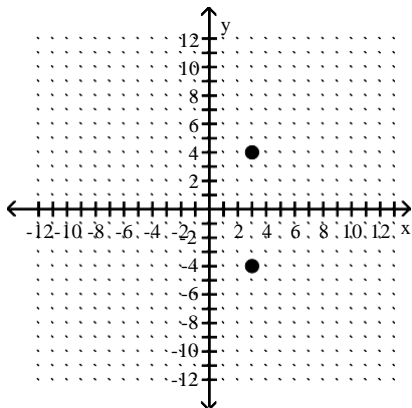

B)

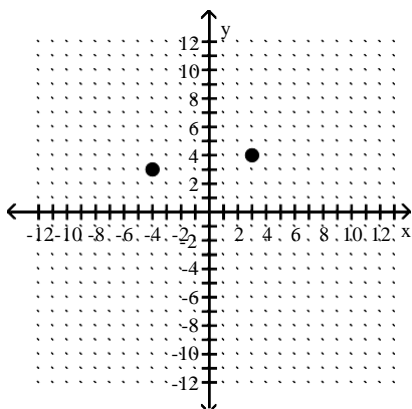

C)

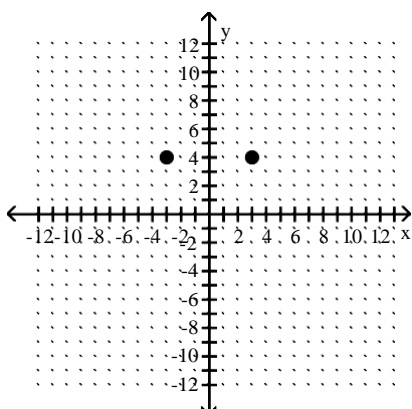

D)

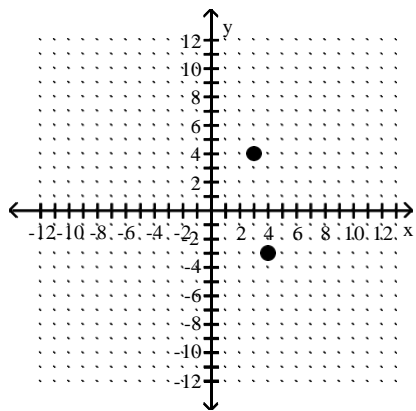

Answer: A

433) Plot the point $(-8, -7)$, then plot the point that is symmetric to $(-8, -7)$ with respect to the x-axis.

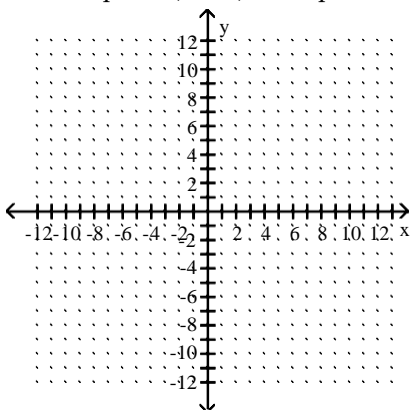

A)

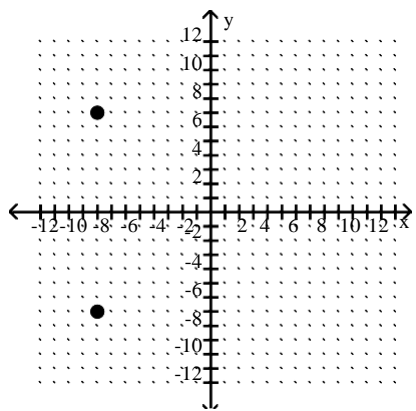

B)

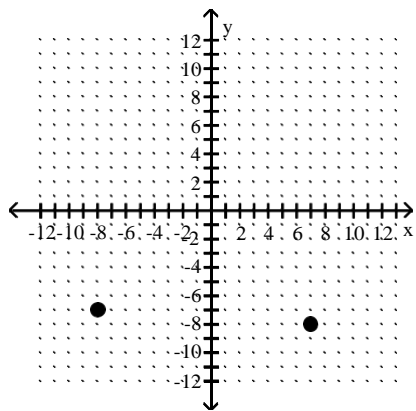

C)

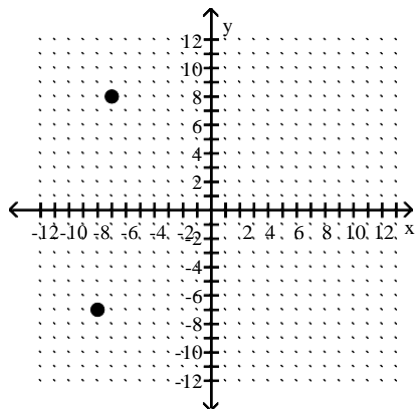

D)

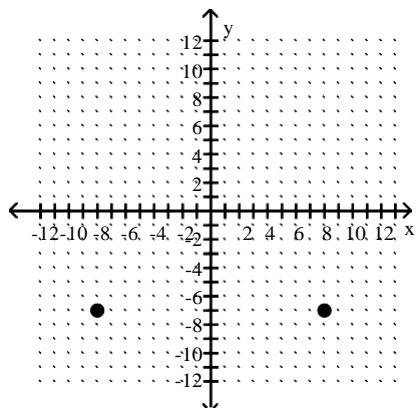

Answer: A

434) Plot the point $(-5, 0)$, then plot the point that is symmetric to $(-5, 0)$ with respect to the x -axis.

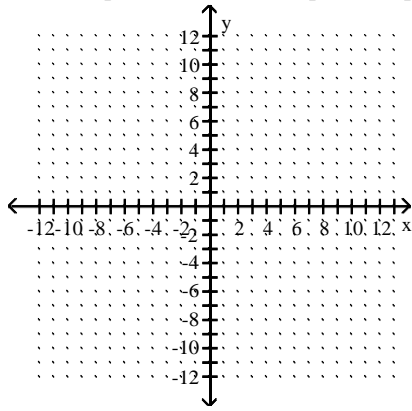

A)

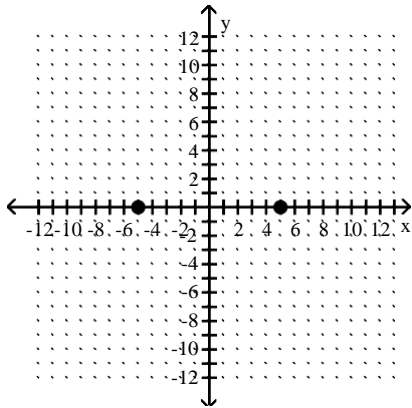

B)

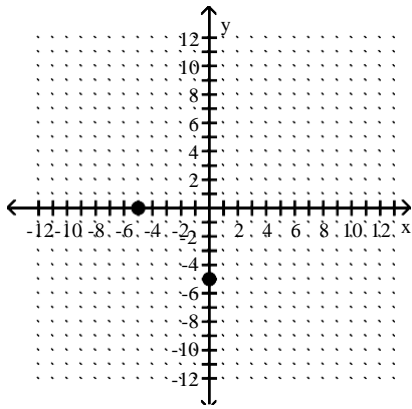

C)

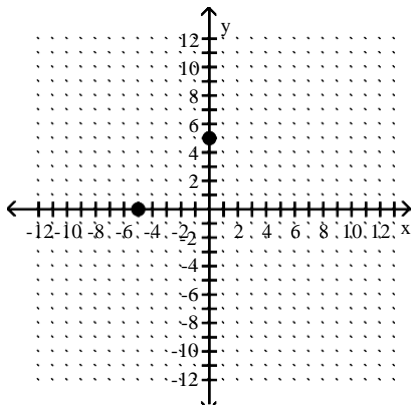

D)

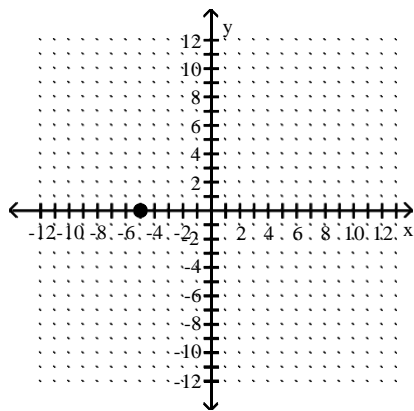

Answer: D

435) Plot the point $(7, 2)$, then plot the point that is symmetric to $(7, 2)$ with respect to the y -axis.

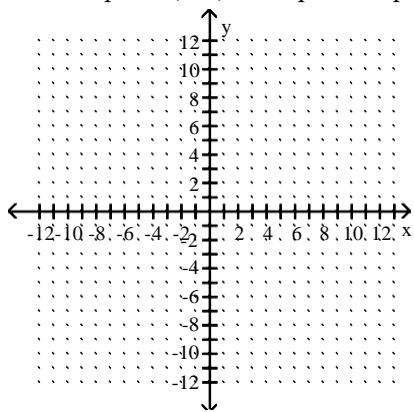

A)

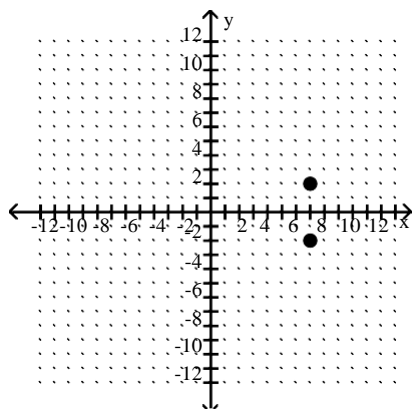

B)

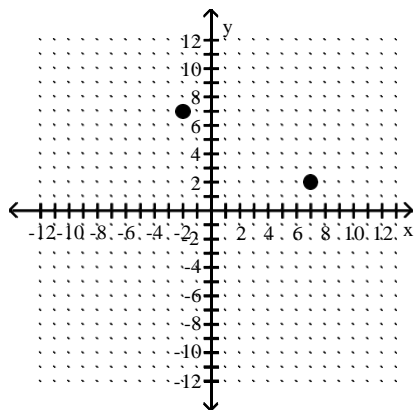

C)

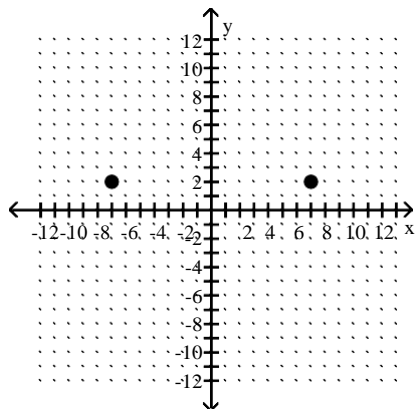

D)

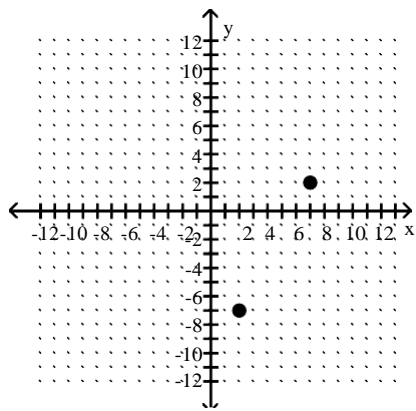

Answer: C

436) Plot the point $(-2, 1)$, then plot the point that is symmetric to $(-2, 1)$ with respect to the y -axis.

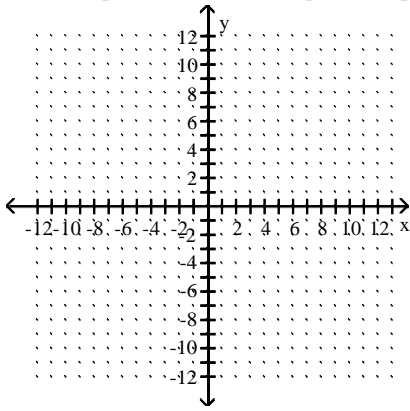

A)

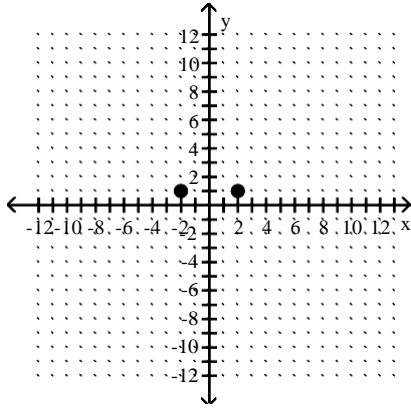

B)

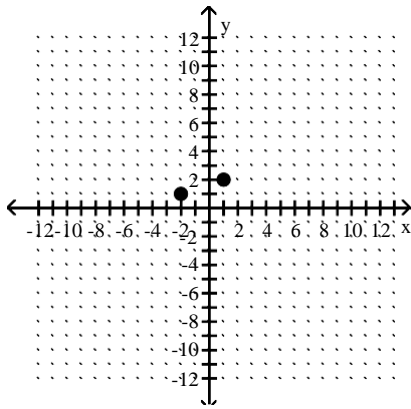

C)

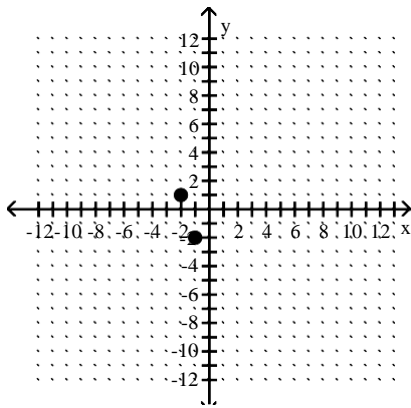

D)

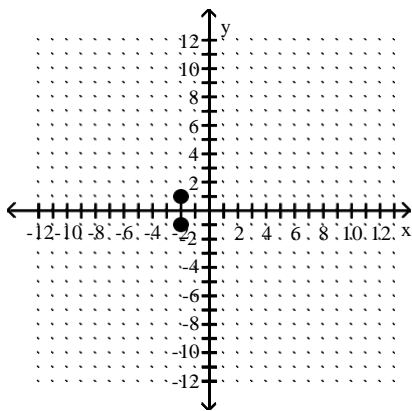

Answer: A

437) Plot the point $(1, 0)$, then plot the point that is symmetric to $(1, 0)$ with respect to the y -axis.

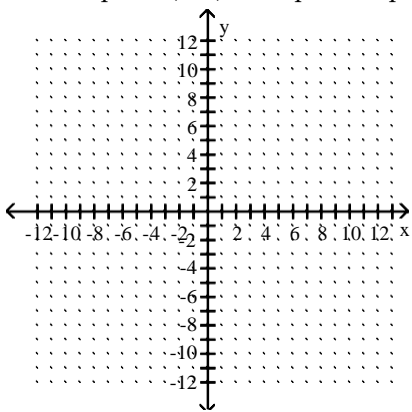

A)

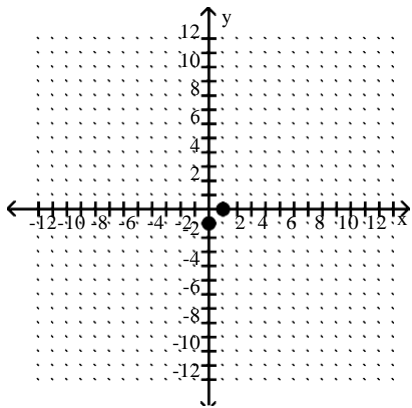

B)

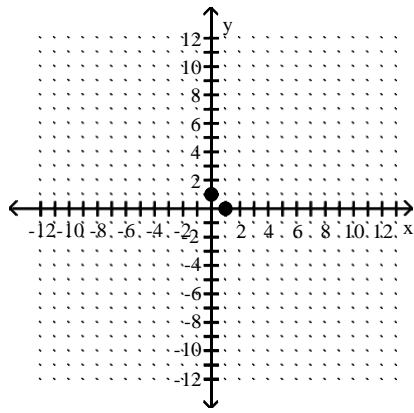

C)

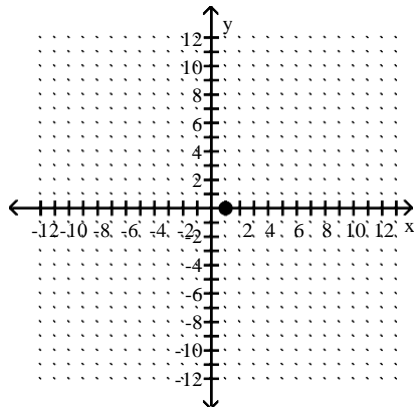

D)

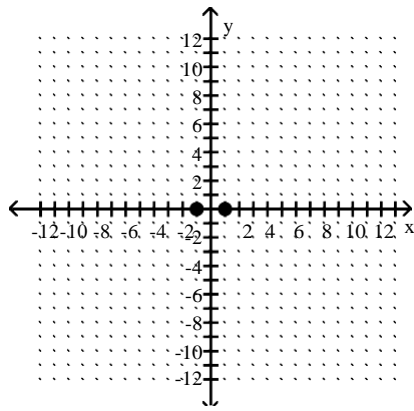

Answer: D

438) Plot the point $(0, -2)$, then plot the point that is symmetric to $(0, -2)$ with respect to the y -axis.

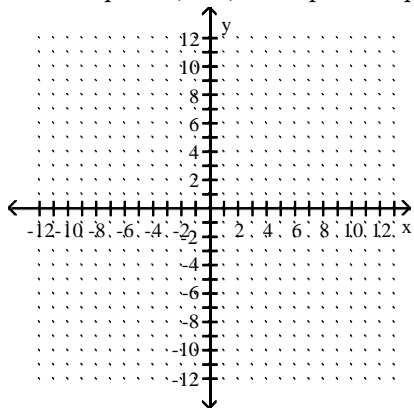

A)

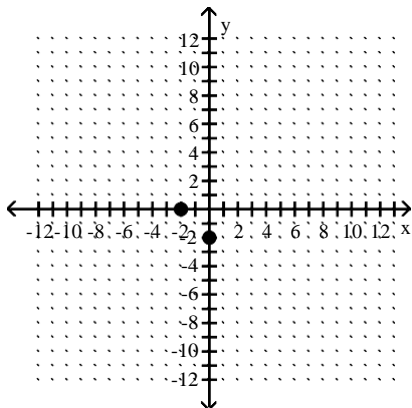

B)

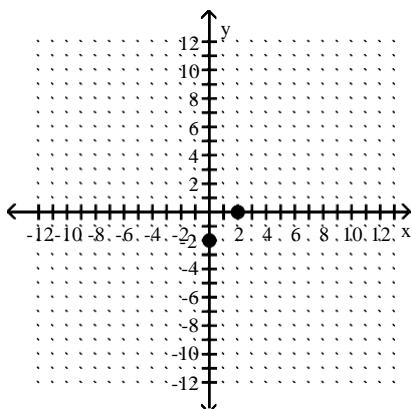

C)

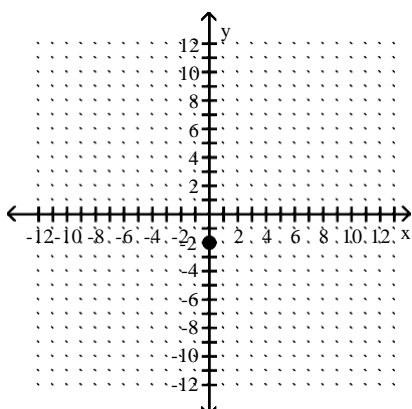

D)

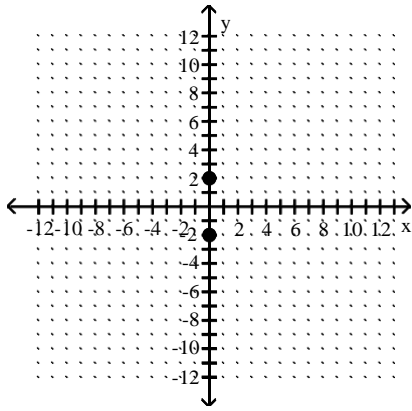

Answer: C

439) Plot the point $(4, 5)$, then plot the point that is symmetric to $(4, 5)$ with respect to the origin.

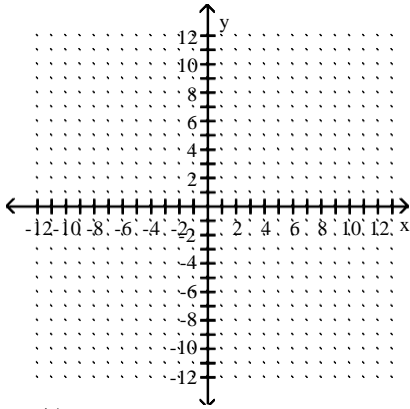

A)

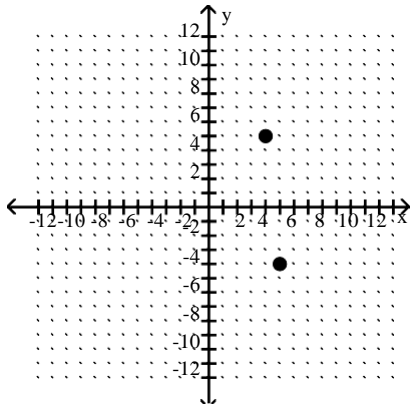

B)

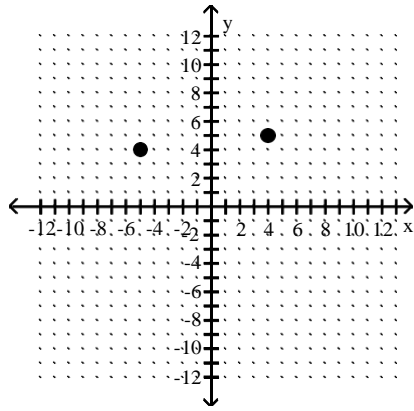

C)

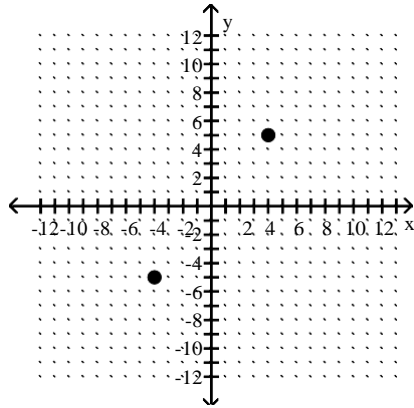

D)

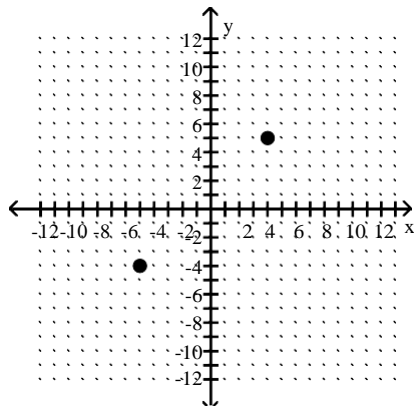

Answer: C

440) Plot the point $(5, -4)$, then plot the point that is symmetric to $(5, -4)$ with respect to the origin.

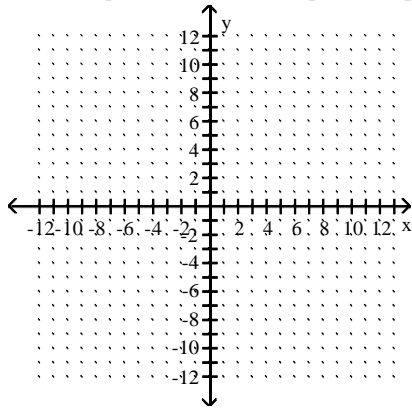

A)

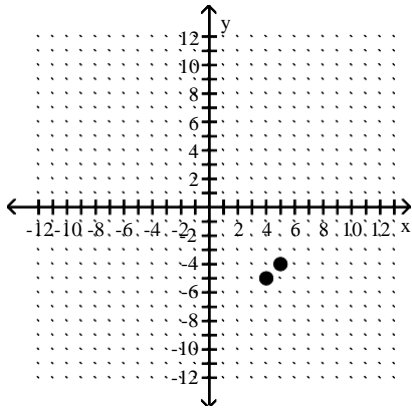

B)

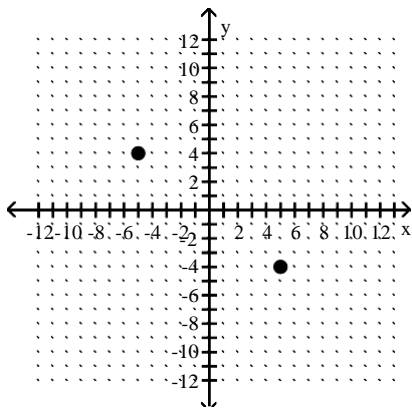

C)

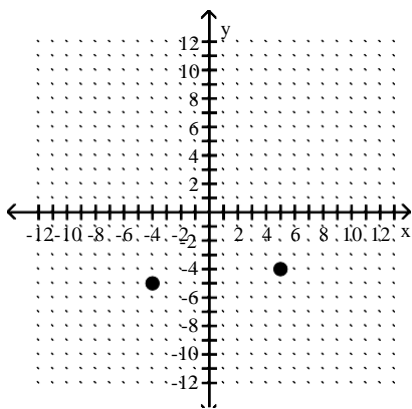

D)

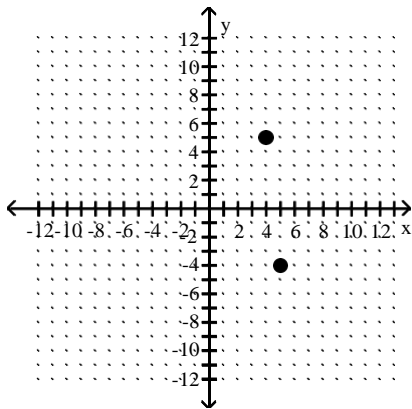

Answer: B

441) Plot the point $(2, 0)$, then plot the point that is symmetric to $(2, 0)$ with respect to the origin.

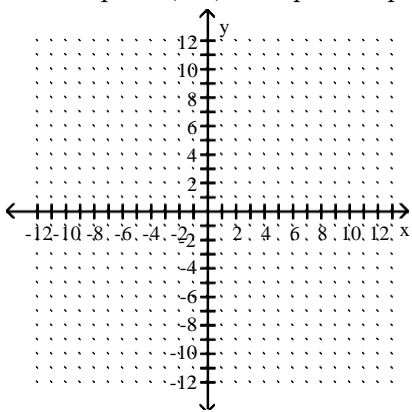

A)

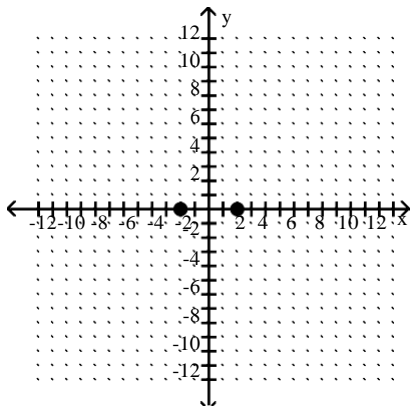

B)

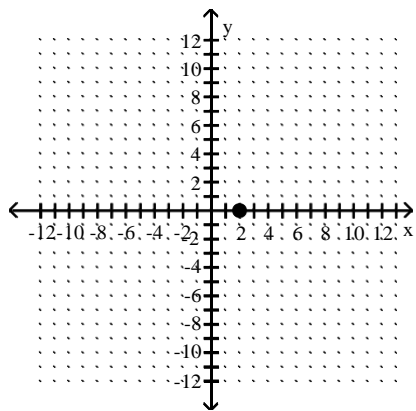

C)

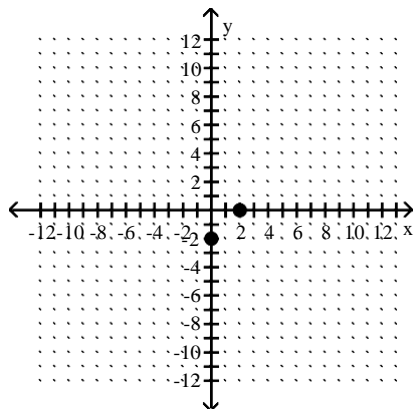

D)

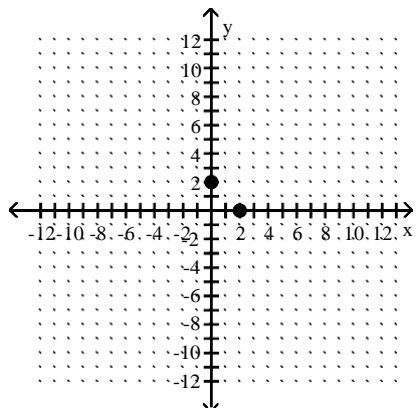

Answer: A

Determine whether the equation has a graph that is symmetric with respect to the y-axis, the x-axis, the origin, or none of these.

442) $y = 2x^2 - 3$

- A) y-axis only
- B) x-axis, y-axis, origin
- C) origin only
- D) x-axis only

Answer: A

443) $y = (x + 8)(x + 6)$

- A) y-axis only
- B) x-axis, y-axis, origin
- C) none of these
- D) x-axis only

Answer: C

444) $y = -5x^3 + 9x$

- A) x-axis only
- B) origin only
- C) y-axis only
- D) x-axis, y-axis, origin

Answer: B

445) $y = -8x^5 - 6x^3$

- A) origin only
- B) y-axis only
- C) none of these
- D) x-axis, y-axis, origin

Answer: A

446) $x^2 - y^2 = 7$

- A) x-axis, y-axis
- B) x-axis, y-axis, origin
- C) origin only
- D) y-axis, origin

Answer: B

447) $y = -0.12x^4 + x^2 - 9$

- A) y-axis only
- B) origin only
- C) none of these
- D) x-axis only

Answer: A

448) $y = 9x^4 - 9x + 3$

- A) y-axis only
- B) x-axis only
- C) none of these
- D) origin only

Answer: C

Determine if the function is even, odd, or neither.

449) $f(x) = 5x^2 - 5$

- A) Odd
- B) Even
- C) Neither

Answer: B

450) $f(x) = x^4 - 4x^2 + 1$

- A) Even
- B) Neither
- C) Odd

Answer: A

451) $f(x) = -4x^3 + 7x$

- A) Even
- B) Odd
- C) Neither

Answer: B

452) $f(x) = -6x^5 + 4x^3$

- A) Neither
- B) Even
- C) Odd

Answer: C

453) $f(x) = 3x^4 - 5x - 8$

- A) Odd
- B) Neither
- C) Even

Answer: B

454) $f(x) = -3x^3 + 9x^2 - 3$

- A) Even
- B) Neither
- C) Odd

Answer: B

Describe the transformations and give the equation for the graph.

455)

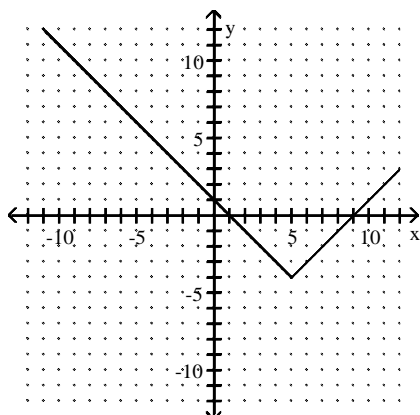

- A) It is the graph of $f(x) = |x|$ translated 5 units to the right and 4 units down. The equation is $y = |x + 5| + 4$
- B) It is the graph of $f(x) = |x|$ translated 5 units to the right and 4 units down. The equation is $y = |x - 5| - 4$
- C) It is the graph of $f(x) = |x|$ translated 5 units to the right and 4 units down. The equation is $y = |x - 5| + 4$
- D) It is the graph of $f(x) = |x|$ translated 5 units to the right and 4 units down. The equation is $y = |x + 5| - 4$

Answer: B

264)

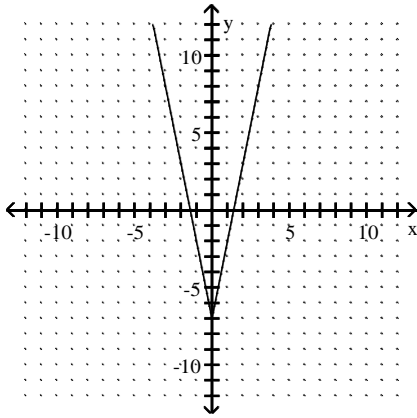

- A) It is the graph of $f(x) = |x|$ shrunken vertically by a factor of 5 and translated 7 units down. The equation is $y = 5|x| + 7$
- B) It is the graph of $f(x) = |x|$ stretched vertically by a factor of 5 and translated 7 units down. The equation is $y = \frac{1}{5}|x| - 7$
- C) It is the graph of $f(x) = |x|$ shrunken vertically by a factor of 5 and translated 7 units down. The equation is $y = \frac{1}{5}|x| - 7$
- D) It is the graph of $f(x) = |x|$ stretched vertically by a factor of 5 and translated 7 units down. The equation is $y = \frac{1}{5}|x| + 7$

Answer: B

265)

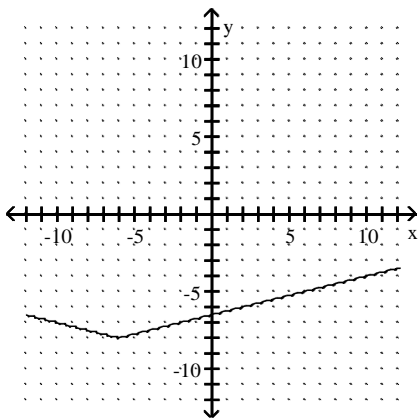

A) It is the graph of $f(x) = |x|$ translated 6 units to the left, shrunken vertically by a factor of $\frac{1}{4}$ and translated 8

units down. The equation is $y = \frac{1}{4}|x - 6| - 8$

B) It is the graph of $f(x) = |x|$ translated 6 units to the left, stretched vertically by a factor of 4 and translated 8

units down. The equation is $y = 4|x - 6| + 8$

C) It is the graph of $f(x) = |x|$ translated 6 units to the left, stretched vertically by a factor of 4 and translated 8

units down. The equation is $y = 4|x + 6| - 8$

Answer: D

458)

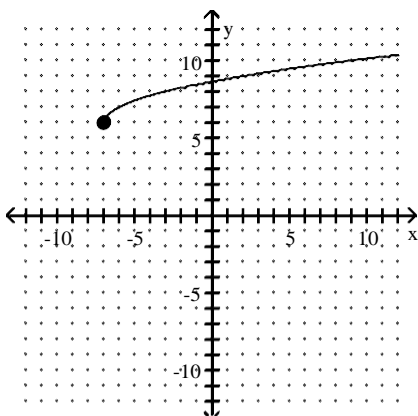

A) It is the graph of $f(x) = \sqrt{x}$ translated 7 units to the left and translated 6 units up. The equation is $y = \sqrt{x + 7} + 6$

B) It is the graph of $f(x) = \sqrt{x}$ translated 7 units to the left and translated 6 units up. The equation is $y = \sqrt{x + 7} - 6$

C) It is the graph of $f(x) = \sqrt{x}$ translated 7 units to the left and translated 6 units up. The equation is $y = \sqrt{x - 7} + 6$

D) It is the graph of $f(x) = \sqrt{x}$ translated 7 units to the left and translated 6 units up. The equation is $y = \sqrt{x - 7} - 6$

Answer: A

266)

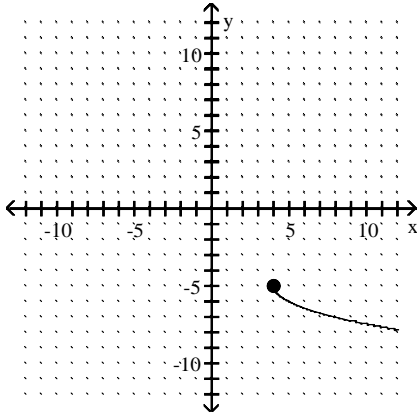

- A) It is the graph of $f(x) = \sqrt{x}$ translated 4 units to the right, reflected across the x-axis and translated 5 units down. The equation is $y = -\sqrt{x+4} - 5$
- B) It is the graph of $f(x) = \sqrt{x}$ translated 4 units to the right, reflected across the x-axis and translated 5 units down. The equation is $y = \sqrt{-x+4} - 5$
- C) It is the graph of $f(x) = \sqrt{x}$ translated 4 units to the right, reflected across the x-axis and translated 5 units down. The equation is $y = -\sqrt{x-4} - 5$
- D) It is the graph of $f(x) = \sqrt{x}$ translated 4 units to the right, reflected across the y-axis and translated 5 units down. The equation is $y = \sqrt{-x-4} - 5$

Answer: C

267)

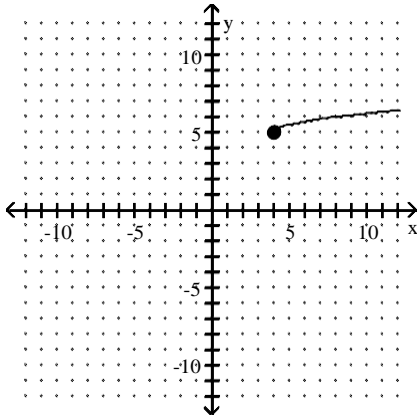

A) It is the graph of $f(x) = \sqrt{x}$ translated 4 units to the right, shrunken vertically by a factor of $\frac{1}{2}$ and

translated 5 units up. The equation is $y = \frac{1}{2}\sqrt{x+4} + 5$

B) It is the graph of $f(x) = \sqrt{x}$ translated 4 units to the right, stretched vertically by a factor of 2 and translated 5 units up. The equation is $y = 2\sqrt{x-4} + 5$

C) It is the graph of $f(x) = \sqrt{x}$ translated 4 units to the right, shrunken vertically by a factor of $\frac{1}{2}$ and

translated 5 units up. The equation is $y = \frac{1}{2}\sqrt{x-4} + 5$

D) It is the graph of $f(x) = \sqrt{x}$ translated 4 units to the right, stretched vertically by a factor of 2 and translated 5 units up. The equation is $y = 2\sqrt{x+4} + 5$

Answer: C

Evaluate.

461) Find $(f - g)(1)$ when $f(x) = 3x^2 + 3$ and $g(x) = x + 6$.

- A) 11
- B) -7
- C) 1
- D) -1

Answer: D

462) Find $(f + g)(-1)$ when $f(x) = x + 3$ and $g(x) = x + 6$.

- A) -11
- B) 7
- C) -5
- D) 1

Answer: B

463) Find $\begin{pmatrix} f \\ g \end{pmatrix}(-3)$ when $f(x) = 2x - 2$ and $g(x) = 2x^2 + 14x + 5$.

A) $-\frac{2}{19}$

B) $-\frac{2}{19}$

C) $\frac{8}{19}$

D) $\frac{1}{2}$

Answer: C

464) Find $(fg)(-4)$ when $f(x) = x - 1$ and $g(x) = 5x^2 + 19x - 3$.

A) 315

B) -231

C) -5

D) -3

Answer: C

For the pair of functions, find the indicated sum, difference, product, or quotient.

465) $f(x) = 3x - 3$, $g(x) = 5x - 9$

Find $(f - g)(x)$.

A) $2x - 6$

B) $-2x - 12$

C) $8x - 12$

D) $-2x + 6$

Answer: D

466) $f(x) = 7 - 8x$, $g(x) = -2x + 8$

Find $(f + g)(x)$.

A) $-10x + 15$

B) $-6x + 15$

C) $-2x + 7$

D) $5x$

Answer: A

467) $f(x) = 6 - 3x$, $g(x) = -8x^2 + 3$

Find $(f + g)(x)$.

A) $-8x^2 - 3x + 9$

B) $-11x^2 - 3x + 9$

C) $-8x^2 + 6$

D) $-11x + 9$

Answer: A

468) $f(x) = 2x^2 - 5x$, $g(x) = x^2 - 2x - 15$

Find $\left(\frac{f}{g}\right)(x)$.

A) $\frac{2x}{x+1}$

B) $\frac{2x^2 - 5x}{x^2 - 2x - 15}$

C) $\frac{2x - 5}{-2}$

D) $\frac{2 - x}{15}$

Answer: B

469) $f(x) = 4x + 8$, $g(x) = 9x + 7$

Find $(fg)(x)$.

A) $13x^2 + 100x + 15$

B) $36x^2 + 79x + 56$

C) $36x^2 + 100x + 56$

D) $36x^2 + 56$

Answer: C

470) $f(x) = x^2 + 1$, $g(x) = 8x + 5$

Find $(fg)(x)$.

A) $8x^3 + 5$

B) $8x^3 + 8x^2 + 5x + 5$

C) $8x^3 + 5x^2 + 8x + 5$

D) $8x^2 + 8x + 5$

Answer: C

471) $f(x) = \sqrt{5x + 5}$, $g(x) = \sqrt{25x - 4}$

Find $(fg)(x)$.

A) $(5x - 2)(\sqrt{5x + 5})$

B) $(5x + 5)(5x - 2)$

C) $(5x + 5)(25x - 4)$

D) $(\sqrt{5x + 5})(\sqrt{25x - 4})$

Answer: D

472) $f(x) = \sqrt{5x+6}$, $g(x) = \frac{1}{x}$

Find $\left(\frac{f}{g}\right)(x)$.

A) $\frac{1}{x\sqrt{5x+6}}$

B) $\frac{x}{\sqrt{5x+6}}$

C) $\frac{\sqrt{5x+6}}{x}$

D) $x\sqrt{5x+6}$

Answer: D

473) $f(x) = \sqrt{7x+6}$, $g(x) = \frac{1}{x}$

Find $(f - g)(x)$.

A) $\frac{1}{\sqrt{7x+6} - x}$

B) $\sqrt{7x+6} - \frac{1}{x}$

C) $\frac{1}{x} - \sqrt{7x+6}$

D) $\sqrt{7x+6} - \frac{1}{x}$

Answer: D

Find the specified domain.

474) Find the domain of $(f - g)(x)$ when $f(x) = 9x - 5$ and $g(x) = 5x - 4$.

A) $(-\infty, \infty)$

B) $(-9, 5)$

C) $(-5, 9)$

D) $(-9, \infty)$

Answer: A

475) Find the domain of $(fg)(x)$ when $f(x) = \sqrt{3x+2}$ and $g(x) = \sqrt{6x-3}$.

A) $\left[-\frac{1}{2}, \infty\right)$

B) $[0, \infty)$

C) $\left[\frac{1}{2}, \infty\right)$

D) $(-\infty, \infty)$

Answer: C

476) Find the domain of $(f + g)(x)$ when $f(x) = \sqrt{9x - 7}$ and $g(x) = \frac{1}{x}$

- A) $(-\infty, 0) \cup (0, \infty)$
- B) $\left[-\frac{7}{9}, \infty\right)$
- C) $\left[\frac{7}{9}, \infty\right)$
- D) $\left[-\frac{7}{9}, 0\right) \cup (0, \infty)$

Answer: C

477) Find the domain of $\left(\frac{f}{g}\right)(x)$ when $f(x) = \sqrt{3x - 2}$ and $g(x) = \frac{1}{x}$

- A) $\left[-\frac{2}{3}, 0\right) \cup (0, \infty)$
- B) $(-\infty, 0) \cup (0, \infty)$
- C) $\left[\frac{2}{3}, \infty\right)$
- D) $\left[-\frac{2}{3}, \infty\right)$

Answer: C

478) Find the domain of $(f + g)(x)$ when $f(x) = 2x + 5$ and $g(x) = \frac{4}{x - 2}$

- A) $(-\infty, 2) \cup (2, \infty)$
- B) $(-\infty, -2) \cup (-2, \infty)$
- C) $(-\infty, \infty)$
- D) $(-\infty, -4) \cup (-4, \infty)$

Answer: A

479) Find the domain of $(f - g)(x)$ when $f(x) = \frac{3x}{x - 3}$ and $g(x) = \frac{4}{x + 5}$

- A) $(-\infty, -3) \cup (-3, 5) \cup (5, \infty)$
- B) $(-\infty, -5) \cup (-5, 3) \cup (3, \infty)$
- C) $(-\infty, \infty)$
- D) $(-\infty, -4) \cup (-4, -3) \cup (-3, \infty)$

Answer: B

480) Find the domain of $(fg)(x)$ when $f(x) = \frac{2}{x - 7}$ and $g(x) = -9x - 5$

- A) $(-\infty, 5) \cup (5, \infty)$
- B) $(-\infty, 7) \cup (7, \infty)$
- C) $(-\infty, -7) \cup (-7, \infty)$
- D) $(-\infty, \infty)$

Answer: B

481) Find the domain of $\left(\frac{f}{g}\right)(x)$ when $f(x) = 2x - 6$ and $g(x) = 7x - 2$

- A) $(-\infty, 3) \cup (3, \infty)$
- B) $(-\infty, \infty)$
- C) $\left(-\infty, \frac{2}{7}\right) \cup \left(\frac{2}{7}, \infty\right)$
- D) $\left(-\infty, \frac{2}{7}\right) \cup \left(\frac{2}{7}, 3\right) \cup (3, \infty)$

Answer: C

482) Find the domain of $\left(\frac{f}{g}\right)(x)$ when $f(x) = 7x - 5$ and $g(x) = \frac{2}{x - 11}$

- A) $(-\infty, \infty)$
- B) $\left(-\infty, \frac{5}{7}\right) \cup \left(\frac{5}{7}, 11\right) \cup (11, \infty)$
- C) $(-\infty, -11) \cup (-11, \infty)$
- D) $(-\infty, 11) \cup (11, \infty)$

Answer: D

483) Find the domain of $\left(\frac{f}{g}\right)(x)$ when $f(x) = \frac{5}{x - 3}$ and $g(x) = 6 - x$

- A) $(-\infty, 3) \cup (3, 6) \cup (6, \infty)$
- B) $(-\infty, -6) \cup (-6, -3) \cup (-3, \infty)$
- C) $(-\infty, 6) \cup (6, \infty)$
- D) $(-\infty, 3) \cup (3, \infty)$

Answer: A

Solve the problem.

484) The graphs of functions f and g are shown. Use these graphs to find $(f + g)(3)$.

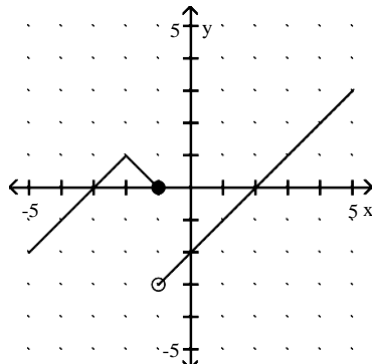

$y = f(x)$

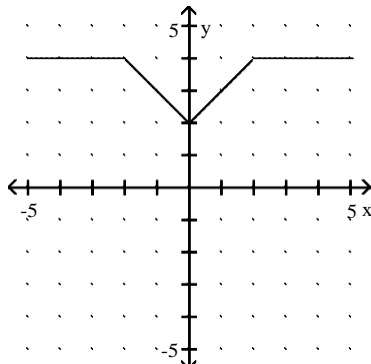

$y = g(x)$

- A) -3
- B) 4
- C) $\frac{1}{4}$
- D) 5

Answer: D

485) The graphs of functions f and g are shown. Use these graphs to find $(fg)(3)$.

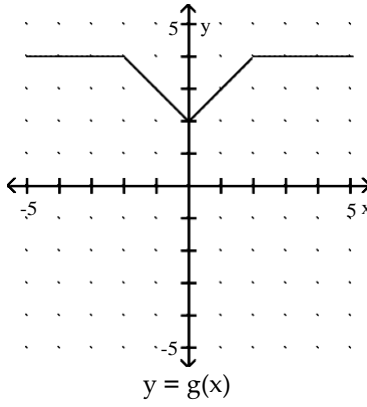
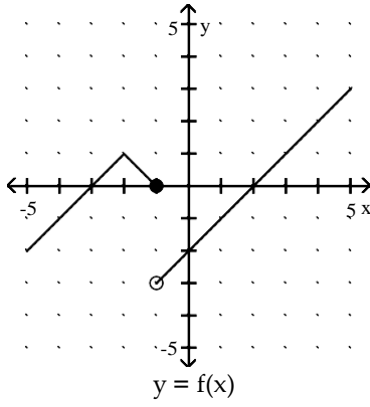

- A) -3
- B) 4
- C) 3
- D) 5

Answer: B

486) Use the graphs to find the value of $(f + g)(3)$.

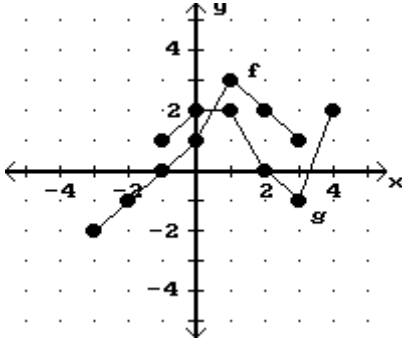

- A) 1
- B) 0
- C) 3
- D) -1

Answer: B

487) Use the graphs to find the value of $(f - g)(-1)$.

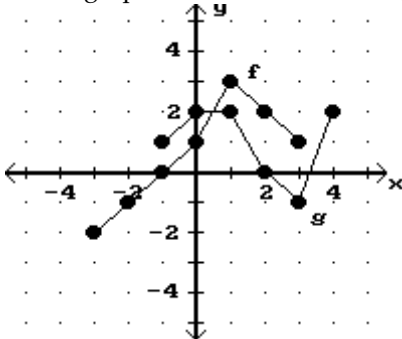

- A) 0
- B) -1
- C) 3
- D) 1

Answer: B

488) Use the graphs to find the value of $(fg)(1)$.

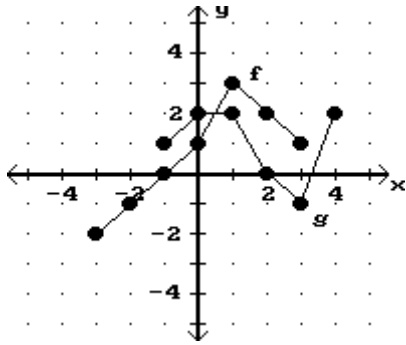

489) $\left. \begin{array}{l} \\ \\ \\ \end{array} \right\} (3)$.

- A) 4
- B) 2
- C) 3
- D) 6

Answer: D

Use the graphs to find the value of $\left(\frac{f}{g} \right)$

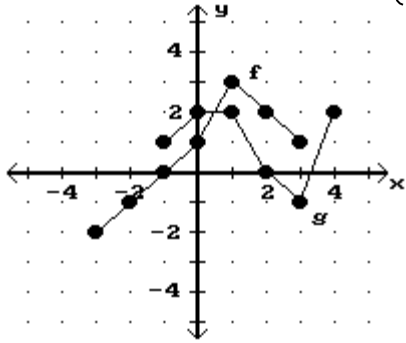

- A) -2
- B) -1
- C) 1
- D) undefined

Answer: B

490) Use the tables to find $(f + g)(-7)$.

x	-7	3	8
$f(x)$	2	2	-4

x	-7	4	8
$g(x)$	9	6	-9

- A) 11
- B) 8
- C) 16
- D) -13

Answer: A

491) Use the tables to find $(fg)(-9)$.

x	-9	-3	5
f(x)	-5	-4	8

x	-9	1	5
g(x)	-7	-4	-6

- A) -48
- B) 81
- C) 16
- D) 35

Answer: D

Compute and simplify the difference quotient $\frac{f(x+h) - f(x)}{h}$, $h \neq 0$.

492) $f(x) = 4x - 9$

- A) $-9h$
- B) $\frac{9}{4}$
- C) 4
- D) 9

Answer: C

493) $f(x) = \frac{1}{x+25}$

- A) $-\frac{1}{(x+1)^2}$
- B) $\frac{1}{(x+h+25)(x+25)}$
- C) $-\frac{1}{(x+h+25)(x+25)}$
- D) $-\frac{25}{(x+h+25)(x+25)}$

Answer: C

494) $f(x) = 7x^2 + 9x$

- A) $14x + 9$
- B) $14x^2 + 7h + 9x$
- C) $21x - 9h + 18$
- D) $14x + 7h + 9$

Answer: D

$$495) f(x) = \frac{x}{7-x}$$

$$A) \frac{x}{(7-x+h)(7-x)}$$

$$B) -\frac{7}{(7-x+h)(7-x)}$$

$$C) \frac{hx}{(7-x-h)(7+x)}$$

$$D) \frac{7}{(7-x-h)(7-x)}$$

Answer: D

$$496) f(x) = \frac{x-15}{x+3}$$

$$A) \frac{18}{(x+h+3)(x+3)}$$

$$B) \frac{18(x+h+3)}{(x+3)}$$

$$C) \frac{19}{(x+3)(x-3)}$$

$$D) -\frac{18}{x(x+3)}$$

Answer: A

Find the requested function value.

$$497) \text{ Find } (f \cdot g)(-6) \text{ when } f(x) = 9x + 2 \text{ and } g(x) = -9x^2 - 2x + 1.$$

$$A) 573$$

$$B) -2797$$

$$C) -24,231$$

$$D) 605$$

Answer: B

$$498) \text{ Find } (g \cdot f)(4) \text{ when } f(x) = 4x - 2 \text{ and } g(x) = -6x^2 - 8x - 8.$$

$$A) -546$$

$$B) -1296$$

$$C) -204$$

$$D) -258$$

Answer: B

$$499) \text{ Find } (g \cdot f)(10) \text{ when } f(x) = \frac{x-1}{3} \text{ and } g(x) = 2x + 3.$$

$$A) 15$$

$$B) \frac{22}{3}$$

$$C) 69$$

$$D) 9$$

Answer: D

Find the requested value.

500) Using the given tables, find $(f \cdot g)(3)$

x	11	7	3	5
f(x)	22	14	6	10

x	5	3	6	4
g(x)	9	5	11	7

- A) 14
- B) 10
- C) 5
- D) 3

Answer: B

501) Using the given tables, find $(g \cdot f)(9)$

x	9	12	10	20
f(x)	10	18	49	51

x	11	20	9	10
g(x)	21	17	20	19

- A) 17
- B) 49
- C) 9
- D) 19

Answer: D

502) Using the given tables, find $(f \cdot f)(3)$

x	3	6	4	2
f(x)	4	3	13	15

x	5	3	6	4
g(x)	9	5	11	7

- A) 13
- B) 7
- C) 3
- D) 11

Answer: A

503) Using the given tables, find $(g \cdot g)(9)$

x	9	12	10	20
f(x)	10	18	49	51

x	11	20	9	10
g(x)	21	17	20	19

- A) 17
- B) 49
- C) 51
- D) 19

Answer: A

For the given functions f and g , find the indicated composition.

504) $f(x) = 3x + 14$, $g(x) = 2x - 1$

$(f \circ g)(x)$

- A) $6x + 17$
- B) $6x + 13$
- C) $6x + 27$
- D) $6x + 11$

Answer: D

505) $f(x) = -5x + 2$, $g(x) = 2x + 7$

$(g \circ f)(x)$

- A) $-10x + 3$
- B) $-10x + 11$
- C) $10x + 11$
- D) $-10x + 37$

Answer: B

506) $f(x) = \frac{4}{x+7}$, $g(x) = \frac{1}{8x}$

$(f \circ g)(x)$

- A) $\frac{32x}{1+56x}$
- B) $\frac{1x+7}{32x}$
- C) $\frac{4x}{1+56x}$
- D) $\frac{32x}{1-56x}$

Answer: A

507) $f(x) = \sqrt{x+5}$, $g(x) = -\frac{1}{x}$

$(g \circ f)(x)$

- A) $\sqrt{-\frac{1}{x}+5}$
- B) $-\frac{1}{\sqrt{1x+5}}$
- C) $\frac{1}{\sqrt{-x+5}}$
- D) $-\frac{1}{\sqrt{x+5}}$

Answer: D

508) $f(x) = \frac{x-8}{9}$, $g(x) = 9x + 8$

$(g \circ f)(x)$

A) $9x + 64$

B) x

C) $x - \frac{8}{9}$

D) $x + 16$

Answer: B

509) $f(x) = \sqrt{x+4}$, $g(x) = 8x - 8$

$(f \circ g)(x)$

A) $2\sqrt{2x+1}$

B) $8\sqrt{x-4}$

C) $8\sqrt{x+4} - 8$

D) $2\sqrt{2x-1}$

Answer: D

510) $f(x) = 4x^2 + 4x + 3$, $g(x) = 4x - 4$

$(g \circ f)(x)$

A) $4x^2 + 4x - 1$

B) $4x^2 + 16x + 8$

C) $16x^2 + 16x + 8$

D) $16x^2 + 16x + 16$

Answer: C

Determine whether $(f \circ g)(x) = x$ and whether $(g \circ f)(x) = x$.

511) $f(x) = \sqrt[5]{x-12}$, $g(x) = x^5 + 12$

A) Yes, yes

B) No, no

C) Yes, no

D) No, yes

Answer: A

512) $f(x) = x^2 + 3$, $g(x) = \sqrt{x} - 3$

A) Yes, yes

B) Yes, no

C) No, yes

D) No, no

Answer: D

513) $f(x) = \frac{1}{x}$, $g(x) = x$

A) No, yes

B) Yes, yes

C) No, no

D) Yes, no

Answer: C

514) $f(x) = \sqrt{x+1}$, $g(x) = x^2$

- A) No, no
- B) Yes, no
- C) Yes, yes
- D) No, yes

Answer: A

515) $f(x) = x^3 + 8$, $g(x) = \sqrt[3]{x-8}$

- A) Yes, no
- B) No, yes
- C) Yes, yes
- D) No, no

Answer: C

Consider the function h as defined. Find functions f and g so that $(f \circ g)(x) = h(x)$.

516) $h(x) = \frac{1}{x^2 - 7}$

A) $f(x) = \frac{1}{x^2}$, $g(x) = x - 7$

B) $f(x) = \frac{1}{x^2}$, $g(x) = -\frac{1}{7}$

C) $f(x) = \frac{1}{x}$, $g(x) = x^2 - 7$

D) $f(x) = \frac{1}{7}$, $g(x) = x^2 - 7$

Answer: C

517) $h(x) = |2x + 8|$

A) $f(x) = x$, $g(x) = 2x + 8$

B) $f(x) = |-x|$, $g(x) = 2x - 8$

C) $f(x) = -|x|$, $g(x) = 2x + 8$

D) $f(x) = |x|$, $g(x) = 2x + 8$

Answer: D

518) $h(x) = \frac{8}{x^2} + 10$

A) $f(x) = x$, $g(x) = \frac{8}{x} + 10$

B) $f(x) = \frac{8}{x^2}$, $g(x) = 10$

C) $f(x) = \frac{1}{x}$, $g(x) = \frac{8}{x} + 10$

D) $f(x) = x + 10$, $g(x) = \frac{8}{x^2}$

Answer: D

$$519) h(x) = \frac{5}{\sqrt{7x+9}}$$

A) $f(x) = 5, g(x) = \sqrt{7+9}$

B) $f(x) = \frac{5}{\sqrt{x}}, g(x) = 7x + 9$

C) $f(x) = \frac{5}{x}, g(x) = 7x + 9$

D) $f(x) = \sqrt{7x+9}, g(x) = 5$

Answer: B

$$520) h(x) = (5x + 6)^5$$

A) $f(x) = (5x)^5, g(x) = 6$

B) $f(x) = x^5, g(x) = 5x + 6$

C) $f(x) = 5x^5, g(x) = x + 6$

D) $f(x) = 5x + 6, g(x) = x^5$

Answer: B

A new chocolate company is estimating how many candy bars per week college students will consume of their line of products. The graph shows the probable number of candy bars students (age 18-22) will consume from year 0 to year 10. $B(x)$ gives the number of candy bars for boys, $G(x)$ gives the number of candy bars for girls, and $T(x)$ gives the total number for both groups. Use the graph to answer the question.

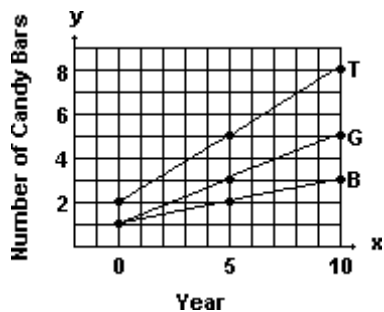

521) Estimate $B(4)$ and $G(4)$ and use your estimates to estimate $T(4)$.

A) 1.5; 2.5; 4.0

B) 2.0; 2.8; 4.8

C) 1.8; 2.5; 4.3

D) 2.0; 3.0; 5.0

Answer: B

522) Estimate $B(7)$ and $G(7)$ and use your estimates to estimate $T(7)$.

A) 3.5; 4.2; 7.7

B) 2.3; 4.0; 6.3

C) 2.5; 4.0; 6.5

D) 2.2; 4.3; 6.5

Answer: D

- 523) Use the slopes of the line segments to decide in which period (0-5 or 5-10) the number of candy bars per week increased more rapidly.
- A) The number of candy bars increased at the same rate in both periods
 - B) 5-10
 - C) 0-5

Answer: A

Solve the problem.

- 524) The cost of manufacturing clocks is given by $C(x) = 70 + 37x - x^2$. Also, it is known that in t hours the number of clocks that can be produced is given by $x = 2t$, where $1 \leq t \leq 12$. Express C as a function of t .
- A) $C(t) = 70 + 37t + t^2$
 - B) $C(t) = 70 + 37t - 2$
 - C) $C(t) = 70 + 74t - 4t$
 - D) $C(t) = 70 + 74t - 4t^2$

Answer: D

- 525) The radius r of a circle of known area A is given by $r = \sqrt{A/\pi}$, where $\pi \approx 3.1416$. Find the radius and circumference of a circle with an area of 46.32 sq ft. (Round results to two decimal places.)
- A) $r = 3.84$ ft, $C = 24.13$ sq ft
 - B) $r = 3.84$ ft, $C = 8.86$ ft
 - C) $r = 14.75$ ft, $C = 92.68$ ft
 - D) $r = 3.84$ ft, $C = 24.13$ ft

Answer: D

- 526) The volume of water added to a circular drum of radius r is given by $V_w = 40t$, where V_w is volume in cu ft and t is time in sec. Find the depth of water in a drum of radius 4 ft after adding water for 19 sec. (Round result to one decimal place.)
- A) 30.2 ft
 - B) 47.4 ft
 - C) 3.9 ft
 - D) 15.1 ft

Answer: D

- 527) A furniture store buys 165 footstools from a distributor at a cost of \$210 each plus an overhead charge of \$50 per order. The retail markup is 45% on the total price paid. Find the profit on the sale of one footstool.
- A) \$94.64
 - B) \$94.50
 - C) \$94.36
 - D) \$9464.00

Answer: A

CHAPTER 2, FORM A
COLLEGE ALGEBRA

NAME _____
DATE _____

1. Match the set described in Column I with the correct interval notation from Column II. Choices in Column II may be used once, more than once, or not at all.

I

- a. Domain of $f(x) = \sqrt{x-3}$
 b. Range of $f(x) = \sqrt{x} - 3$
 c. Domain of $f(x) = x^2 - 16$
 d. Range of $f(x) = x^2 - 7$
 e. Domain of $f(x) = \sqrt[3]{x-2}$
 f. Range of $f(x) = \sqrt[3]{x} + 2$
 g. Domain of $f(x) = |x+2|$
 h. Range of $f(x) = |x| + 3$
 i. Domain of $y = 2x^2$
 j. Range of $y = 2x^2$

II

- A. $(-\infty, \infty)$
 B. $[3, \infty)$
 C. $[0, 2]$
 D. $[0, \infty)$
 E. $[-3, 3]$
 F. $(-\infty, -2]$
 G. $[-3, \infty)$
 H. $[-7, \infty)$

1. a. _____
 b. _____
 c. _____
 d. _____
 e. _____
 f. _____
 g. _____
 h. _____
 i. _____
 j. _____

The graph shows the line that passes through the points $(-5, -3)$ and $(-1, 4)$. Refer to it to answer Exercises 2–6.

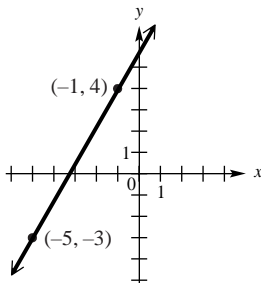

2. What is the slope of the line? 2. _____
 3. What is the distance between the two points shown? 3. _____
 4. What are the coordinates of the midpoint of the segment joining the two points? 4. _____
 5. Find the standard form of the equation of the line. 5. _____
 6. Write the linear function defined by $f(x) = ax + b$ that has this line as its graph. 6. _____

CHAPTER 2, FORM A

Tell whether each graph is that of a function. Give the domain and the range. If it is a function, give the intervals where it is increasing, decreasing, or constant.

7.

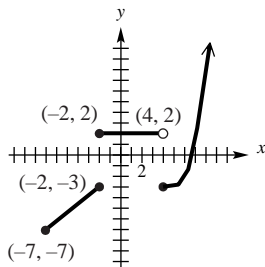

7.

8.

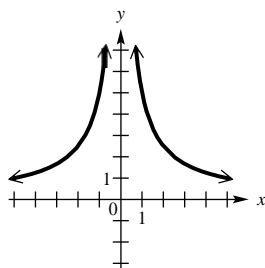

8.

9. Suppose point P has coordinates $\left(1, \left(-\frac{1}{5}, \frac{2}{7}\right)\right)$.

a. What is the equation of the vertical line through P ?

9. a. _____

b. What is the equation of the horizontal line through P ?

b. _____

10. Find the slope-intercept form of the equation of the line passing through $(2, 5)$ and

a. parallel to the graph of $y = 4x - 7$;

10. a. _____

b. perpendicular to the graph of $y = 4x - 7$.

b. _____

Graph each relation.

11. $x = 2|y - 3| + 1$

11.

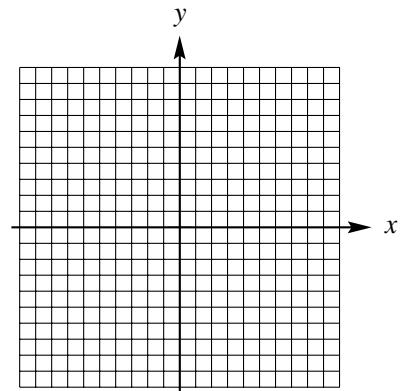

CHAPTER 2, FORM A

12. $f(x) = \lfloor x \rfloor + 2$

12.

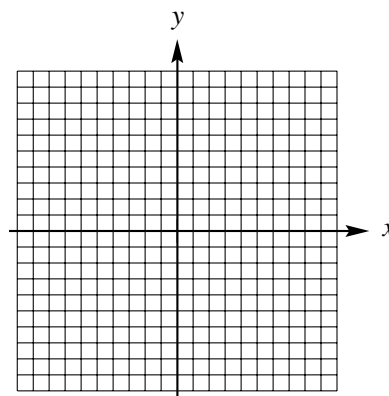

13. $f(x) = \begin{cases} 2x-1 & \text{if } x < 0 \\ -3x-1 & \text{if } x \geq 0 \end{cases}$

13.

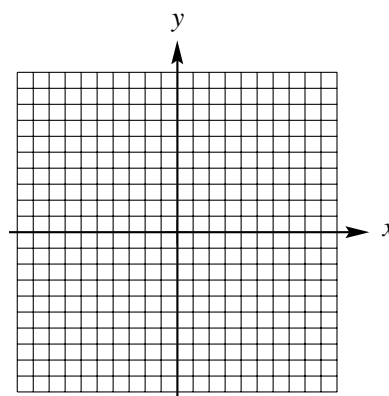

14. Explain how the graph of $y = -\frac{1}{2}\sqrt{x+3} + 5$ can be obtained from the graph of $y = \sqrt{x}$.

14. _____

15. Determine whether the graph of $2x^2 + 3y^2 = 1$ is symmetric with respect to

15. a. _____
 b. _____
 c. _____

- a. the x-axis,
- b. the y-axis,
- c. the origin.

Given $f(x) = x^2 - 1$ and $g(x) = 2x + 1$, find each of the following. Simplify the expressions when possible.

16. $(f + g)(x)$

16. _____

17. $(fg)(x)$

17. _____

18. the domain of $\frac{g}{f}$

18. _____

CHAPTER 2, FORM A

19.
$$\frac{f(x+h) - f(x)}{h}$$

19. _____

20. $(f - g)(0)$

20. _____

21. $\left| \frac{f}{g} \right|(2)$

21. _____

22. $(f \circ g)(x)$

22. _____

23. $(f \circ g)(-2)$

23. _____

24. $(g \circ f)(x)$

24. _____

25. $(g \circ f)(-2)$

25. _____

CHAPTER 2, FORM B
COLLEGE ALGEBRA

NAME _____
DATE _____

1. Match the set described in Column I with the correct interval notation from Column II. Choices in Column II may be used once, more than once, or not at all.

I	II
a. Domain of $f(x) = \sqrt{x-4}$	A. $(-\infty, \infty)$
b. Range of $f(x) = \sqrt{x}-2$	B. $[-2, \infty)$
c. Domain of $f(x) = x^2 + 5$	C. $[0, 2]$
d. Range of $f(x) = 3x^2$	D. $[0, \infty)$
e. Domain of $f(x) = \sqrt[3]{x}-1$	E. $[-3, 3]$
f. Range of $f(x) = \sqrt[3]{x-8}$	F. $(-\infty, -2]$
g. Domain of $f(x) = x-2 $	G. $[5, \infty)$
h. Range of $f(x) = x +5$	H. $[4, \infty)$
i. Domain of $x = 2y^2$	
j. Range of $x = 2y^2$	

1. a. _____
b. _____
c. _____
d. _____
e. _____
f. _____
g. _____
h. _____
i. _____
j. _____

The graph shows the line that passes through the points $(-2, -1)$ and $(4, -3)$. Refer to it to answer Exercises 2–6.

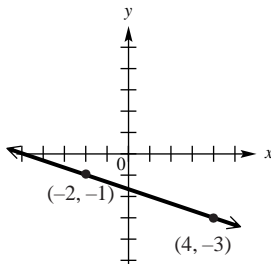

2. What is the slope of the line?
3. What is the distance between the two points shown?
4. What are the coordinates of the midpoint of the *segment* joining the two points?
5. Find the standard form of the equation of the line.
6. Write the linear function defined by $f(x) = ax + b$ that has this line as its graph.

2. _____
3. _____
4. _____
5. _____
6. _____

CHAPTER 2, FORM B

Tell whether each graph is that of a function. Give the domain and the range. If it is a function, give the intervals where it is increasing, decreasing, or constant.

7.

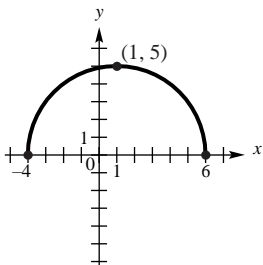

7.

8.

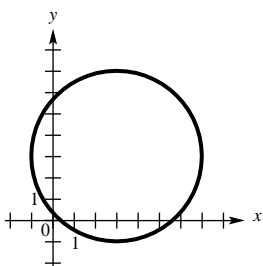

8.

Graph each function.

9. $f(x) = 2 - |3x|$

9.

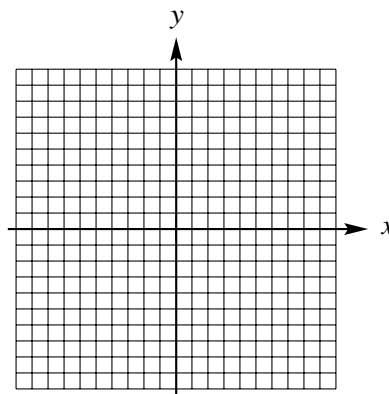

10. $f(x) = \frac{1}{2}x^4$

10.

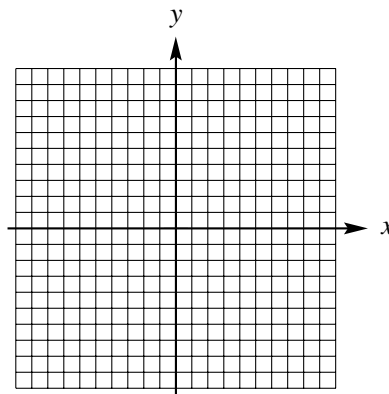

CHAPTER 2, FORM B

$$11. \quad f(x) = \begin{cases} -2x & \text{if } x < -3 \\ 4 & \text{if } -3 \leq x < 2 \\ x-4 & \text{if } x \geq 2 \end{cases}$$

11.

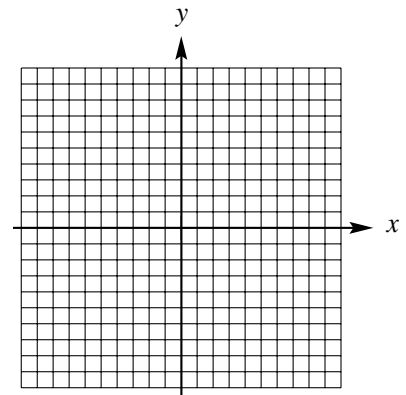

$$12. \quad \text{Suppose point } P \text{ has coordinates } \left(-\frac{3}{4}, \frac{1}{4} \right).$$

- a. What is the equation of the vertical line through P ?
- b. What is the equation of the horizontal line through P ?
13. Find the slope-intercept form of the equation of the line passing through $(-6, 3)$ and

12. a. _____

b. _____

- a. parallel to the graph of $y = -3x - 12$;
- b. perpendicular to the graph of $y = -3x - 12$.

13. a. _____

b. _____

14. Explain how the graph of $y = -\frac{1}{3}\sqrt{x+4} + 2$ can be obtained from the graph of $y = \sqrt{x}$.

14. _____

15. Determine whether the graph of $y^2 = 3x$ is symmetric with respect to

15. a. _____

b. _____

c. _____

- a. the x -axis,
- b. the y -axis,
- c. the origin.

Given $f(x) = 2x^2 + 7x + 6$ and $g(x) = 3x - 2$, find each of the following. Simplify the expressions when possible.

16. $(f - g)(x)$

16. _____

17. $(fg)(x)$

17. _____

18. the domain of $\frac{g}{f}$

18. _____

19. $\frac{f(x+h) - f(x)}{h}$

19. _____

CHAPTER 2, FORM B

20. $(f + g)(0)$

20.

21. $\left(\frac{g}{f}\right)(0)$

21.

22. $(f \circ g)(x)$

22.

23. $(f \circ g)(1)$

23.

24. $(g \circ f)(x)$

24.

25. $(g \circ f)(1)$

25.

CHAPTER 2, FORM C
COLLEGE ALGEBRA

NAME _____
DATE _____

1. Match the set described in Column I with the correct interval notation from Column II. Choices in Column II may be used once, more than once, or not at all.

I	II
a. Domain of $f(x) = \sqrt{x+2}$	A. $(-\infty, \infty)$
b. Range of $f(x) = \sqrt{x}-4$	B. $[-4, \infty)$
c. Domain of $f(x) = x^2 - 16$	C. $[0, 2]$
d. Range of $f(x) = x^2 - 1$	D. $[0, \infty)$
e. Domain of $f(x) = \sqrt[3]{x-2}$	E. $[-3, 3]$
f. Range of $f(x) = \sqrt[3]{x} + 2$	F. $[-3, \infty)$
g. Domain of $f(x) = x+3 $	G. $[-1, \infty)$
h. Range of $f(x) = x - 3$	H. $[-2, \infty)$
i. Domain of $y = x^2 - 3$	
j. Range of $y = 2x^2$	

1. a. _____
b. _____
c. _____
d. _____
e. _____
f. _____
g. _____
h. _____
i. _____
j. _____

The graph shows the line that passes through the points $(-3, 5)$ and $(3, -2)$. Refer to it to answer Exercises 2–6.

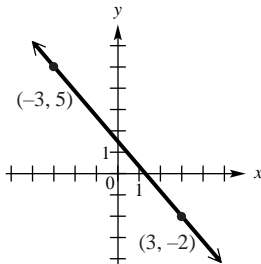

- | | |
|---|----------|
| 2. What is the slope of the line? | 2. _____ |
| 3. What is the distance between the two points shown? | 3. _____ |
| 4. What are the coordinates of the midpoint of the <i>segment</i> joining the two points? | 4. _____ |
| 5. Find the standard form of the equation of the line. | 5. _____ |
| 6. Write the linear function $f(x) = ax + b$ that has this line as its graph. | 6. _____ |

CHAPTER 2, FORM C

Tell whether each graph is that of a function. Give the domain and range. If it is a function, give the intervals where it is increasing, decreasing, or constant.

7.

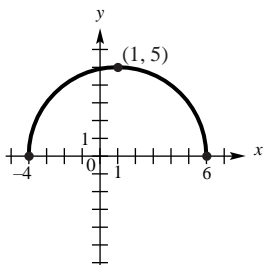

7.

8.

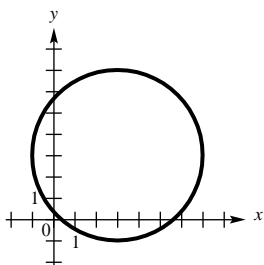

8.

9. Suppose point P has coordinates $(-2, \sqrt{3})$.

a. What is the equation of the vertical line through P ?

9. a.

b. What is the equation of the horizontal line through P ?

b.

10. Find the slope-intercept form of the equation of the line passing through $(4, -2)$.

a. parallel to the graph of $x = \frac{5}{4}y - 2$;

10. a.

b. perpendicular to the graph of $x = \frac{5}{4}y - 2$;

b.

CHAPTER 2, FORM C

Graph each function.

11. $f(x) = \frac{1}{2}|x+1|-2$

11.

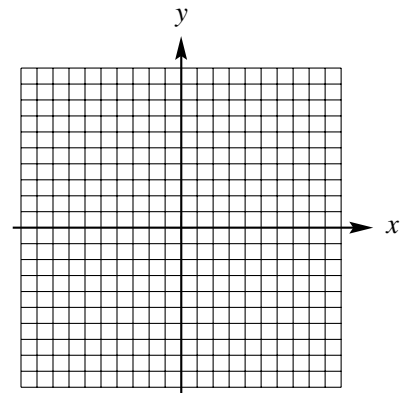

12. $f(x) = \lfloor 2x \rfloor - 2$

12.

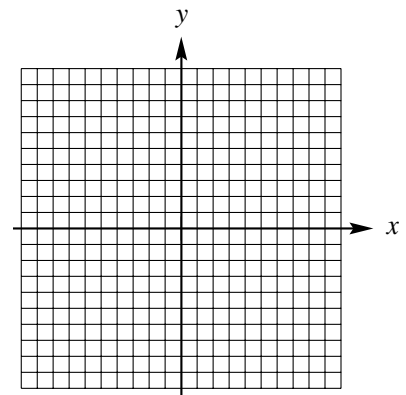

13. $f(x) = \begin{cases} x+1 & \text{if } x \leq -2 \\ -1 & \text{if } x > -2 \end{cases}$

13.

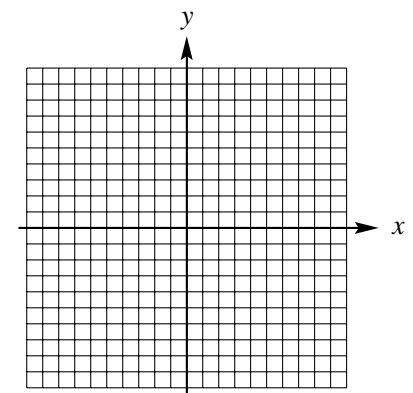

14. Explain how the graph of $y = 3|x+4|+2$ can be obtained from the graph of $y = |x|$

14.

CHAPTER 2, FORM C

15. Determine whether the graph of $y = 3x^2 + 7$ is symmetric with respect to

- a. the x -axis,
- b. the y -axis,
- c. the origin.

15. a. _____
- b. _____
- c. _____

Given $f(x) = 3x^2 - 2$ and $g(x) = 4x + 4$, find each of the following. Simplify the expressions when possible.

16. $(g - f)(x)$

16. _____

17. $(fg)(x)$

17. _____

18. $f(-1)$

18. _____

19. $\frac{f(x+h) - f(x)}{h}$

19. _____

20. $(f + g)(0)$

20. _____

21. $\left(\frac{f}{g}\right)(-2)$

21. _____

22. $(f - g)(x)$

22. _____

23. $(f \circ g)(x)$

23. _____

24. $(f \circ g)(0)$

24. _____

25. $(g \circ f)(x)$

25. _____

CHAPTER 2, FORM D
COLLEGE ALGEBRA

NAME _____
DATE _____

1. Match the set described in Column I with the correct interval notation from Column II. Choices in Column II may be used once, more than once, or not at all.

I	II
a. Domain of $f(x) = \sqrt{x+1}$	A. $(-\infty, -1]$
b. Domain of $f(x) = \sqrt{x} + 1$	B. $(-\infty, \infty)$
c. Domain of $f(x) = x^2 - 25$	C. $[0, 2]$
d. Range of $f(x) = x^2 - 1$	D. $[0, \infty)$
e. Domain of $f(x) = \sqrt[3]{x-2}$	E. $[-3, 3]$
f. Range of $f(x) = \sqrt[3]{x} + 2$	F. $[-3, \infty)$
g. Domain of $f(x) = x+4 $	G. $[-1, \infty)$
h. Range of $f(x) = x - 4$	H. $[-4, \infty)$
i. Domain of $y = x^2 - 4$	
j. Range of $y = 2x^2$	

1. a. _____
b. _____
c. _____
d. _____
e. _____
f. _____
g. _____
h. _____
i. _____
j. _____

The graph shows the line that passes through the points $(-7, -4)$ and $(3, -2)$. Refer to it to answer Exercises 2–6.

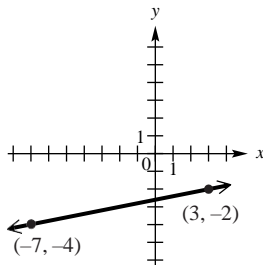

2. What is the slope of the line? 2. _____
3. What is the distance between the two points shown? 3. _____
4. What are the coordinates of the midpoint of the *segment* joining the two points? 4. _____
5. Find the standard form of the equation of the line. 5. _____
6. Write the linear function $f(x) = ax + b$ that has this line as its graph. 6. _____

CHAPTER 2, FORM D

Tell whether each graph is that of a function. Give the domain and range. If it is a function, give the intervals where it is increasing, decreasing, or constant.

7.

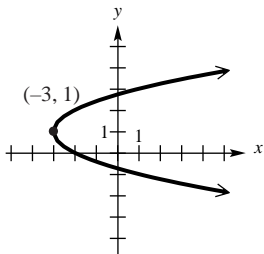

7.

8.

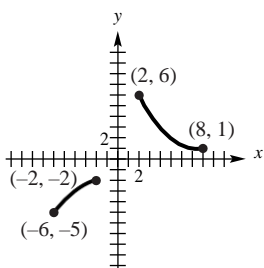

8.

Graph each relation.

9. $f(x) = 3 + |x + 1|$

9.

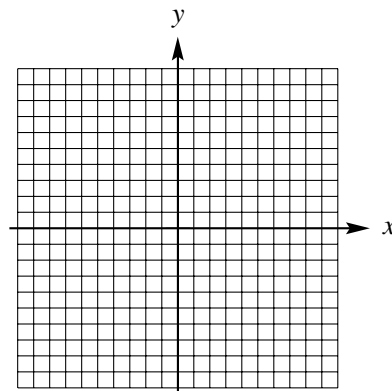

10. $f(x) = \begin{cases} -x & \text{if } x < 0 \\ 2x & \text{if } x \geq 0 \end{cases}$

11.

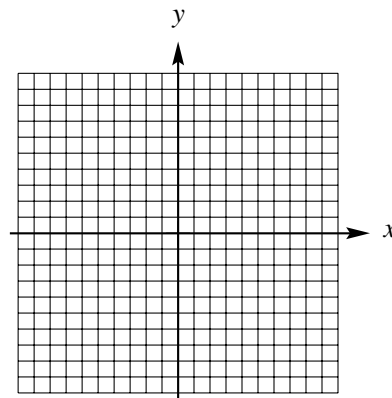

CHAPTER 2, FORM D

11. Suppose point P has coordinates $(-4, 5)$.
- a. What is the equation of the vertical line through P ? **12. a.** _____
- b. What is the equation of the horizontal line through P ? **b.** _____
12. Find the slope-intercept form of the equation of the line passing through $(1, -5)$.
- a. parallel to the graph of $x = -\frac{3}{4}y + 5$; **13. a.** _____
- b. perpendicular to the graph of $x = -\frac{3}{4}y + 5$; **b.** _____
13. Find the slope of the line through points $(11, -5)$ and $(-8, 6)$. **13.** _____
14. Explain how the graph of $y = 3\sqrt{x-4} - 2$ can be obtained from the graph of $y = \sqrt{x}$. **14.** _____
15. Determine whether the graph of $xy = -4$ is symmetric with respect to
- a. the x -axis, **15. a.** _____
- b. the y -axis, **b.** _____
- c. the origin. **c.** _____

Given $f(x) = 2x^3 - 3x - 1$ and $g(x) = 2x + 1$, find each of the following. Simplify the expressions when possible.

16. $(f + g)(x)$ **16.** _____
17. $\left(\frac{f}{g}\right)(x)$ **17.** _____
18. $f(-2)$ **18.** _____
19. $\frac{f(x+h) - f(x)}{h}$ **19.** _____
20. $(g - f)(0)$ **20.** _____
21. $(fg)(-1)$ **21.** _____
22. $(f \circ g)(x)$ **22.** _____
23. $(g \circ f)(x)$ **23.** _____

CHAPTER 2, FORM D

24. $(f \circ g)(2)$

25. $(g \circ f)(2)$

24. _____

25. _____

**CHAPTER 2, FORM E
COLLEGE ALGEBRA**

NAME _____
DATE _____

Choose the best answer.

1a. Which of the following is the domain of $f(x) = \sqrt{3-x}$?

- a. $[0, 3]$ b. $(-\infty, 3]$
c. $[3, \infty)$ d. $(-\infty, \infty)$

1a. _____

1b. Which of the following is the range of $f(x) = x^2 - 49$?

- a. $[-49, \infty)$ b. $[-7, \infty)$
c. $[-7, 7]$ d. $[0, \infty)$

1b. _____

1c. Which of the following is the domain of $f(x) = \sqrt[3]{x+7}$?

- a. $(-\infty, \infty)$ b. $(-\infty, 6]$
c. $[0, \infty)$ d. $[6, \infty)$

1c. _____

1d. Which of the following is the range of $f(x) = |x+1|$?

- a. $[-1, 1]$ b. $[0, 1]$
c. $[0, \infty)$ d. $[1, \infty)$

1d. _____

1e. Which of the following is the domain of $x = y^2$?

- a. $(-\infty, \infty)$ b. $[0, \infty)$
c. $(0, \infty)$ d. $(-\infty, 0]$

1e. _____

The graph shows the line that passes through $(-5, 8)$ and $(4, -3)$. Refer to it to answer Exercises 2–6.

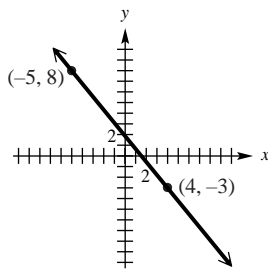

2. What is the slope of the line?

- a. $-\frac{13}{7}$ b. $\frac{11}{9}$
c. $-\frac{11}{9}$ d. 0

2. _____

3. What is the distance between the two points shown?

- a. $\sqrt{26}$ b. $2\sqrt{5}$
c. $\sqrt{122}$ d. $\sqrt{202}$

3. _____

CHAPTER 2, FORM E

4. What are the coordinates of the midpoint of the segment joining the two points?

a. $\left(\frac{1}{2}, \frac{5}{2}\right)$

b. $\left(-\frac{9}{2}, \frac{11}{2}\right)$

c. $\left(\frac{3}{2}, \frac{1}{2}\right)$

d. $(-1, 5)$

4. _____

5. Find the standard form of the equation of the line.

a. $11x + 9y = 127$

b. $11x - 9y = 17$

c. $11x + 9y = 17$

d. $11x - 9y = 127$

5. _____

6. Write the linear function $f(x) = ax + b$ that has this line as its graph.

a. $f(x) = \frac{11}{9}x - \frac{17}{9}$

b. $f(x) = -\frac{11}{9}x + \frac{17}{9}$

c. $f(x) = -\frac{11}{9}x + \frac{127}{9}$

d. $f(x) = \frac{11}{9}x - \frac{127}{9}$

6. _____

Tell whether each graph is that of a function. Give the domain and range.

7.

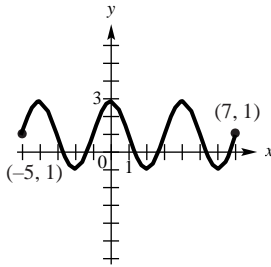

7. _____

- a. Function; domain: $[-5, 7]$; range: $[-1, 3]$
 b. Function; domain: $(-\infty, \infty)$; range: $[-1, 3]$
 c. Function; domain: $[-1, 3]$; range: $[-5, 7]$
 d. Not a function; domain: $[-5, 7]$; range: $[-1, 3]$

8.

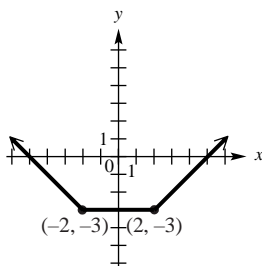

8. _____

- a. Not a function; domain: $(-\infty, \infty)$; range: $[-2, \infty)$
 b. Not a function; domain: $[-5, 5]$; range: $[-3, \infty)$
 c. Function; domain: $(-\infty, \infty)$; range: $[-2, \infty)$
 d. Function; domain: $(-\infty, \infty)$; range: $[-3, \infty)$

CHAPTER 2, FORM E

9. Suppose point P has coordinates $(-6, 1)$.

What is the equation of the vertical line through P ?

- a. $x = -6$ b. $y = -1$
 c. $x = 1$ d. $y = 6$

9. _____

10. Find the slope-intercept form of the equation of the line passing through $(-2, 5)$ perpendicular to the graph of $y = -\frac{1}{8}x + \frac{19}{4}$.

- a. $y = 8x + 21$ b. $y = \frac{1}{3}x - 3$
 c. $y = -8x - 13$ d. $y = -\frac{1}{3}x + 3$

10. _____

Graph each function.

11. $f(x) = 2|x + 1| - 2$

11. _____

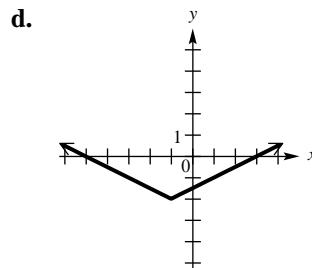
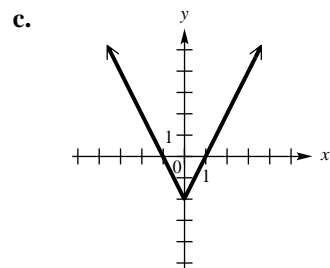
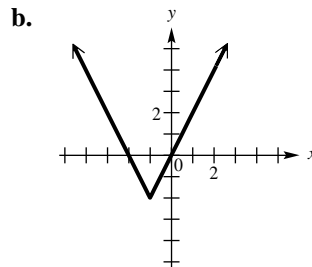
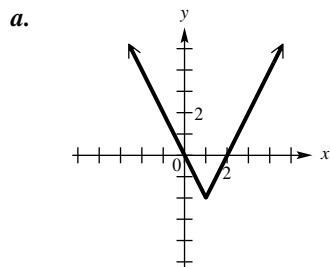

CHAPTER 2, FORM E

12. $f(x) = \begin{cases} \frac{1}{2}x & \text{if } x < 0 \\ 1 & \text{if } x \geq 0 \end{cases}$

12. _____

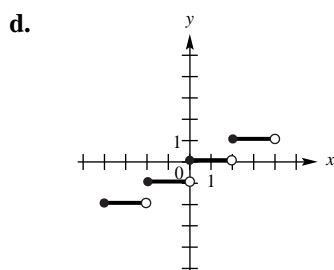
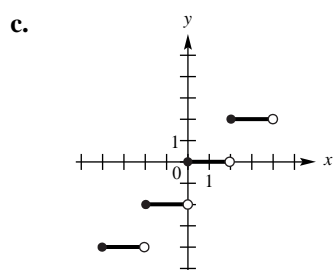
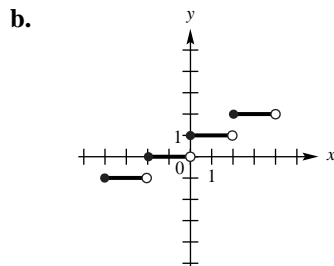
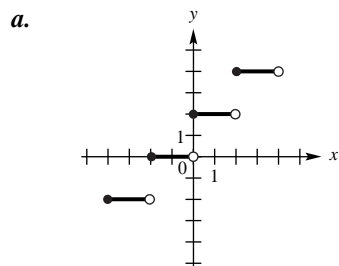

13. $f(x) = \begin{cases} 2 & \text{if } x < -2 \\ 1 & \text{if } -2 < x < 2 \\ -\frac{x}{2} + 1 & \text{if } x \geq 2 \end{cases}$

13. _____

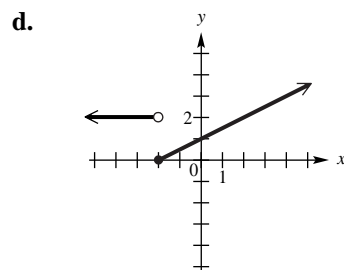
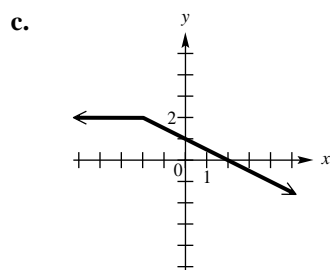
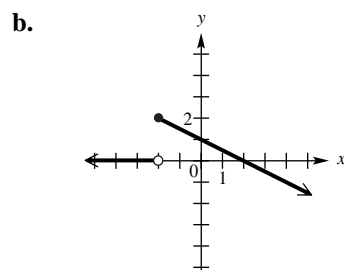
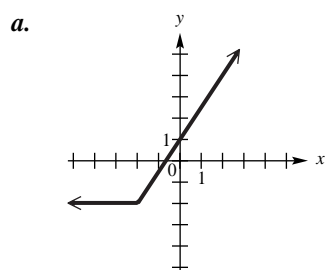

CHAPTER 2, FORM E

14. Explain how the graph of $y = \sqrt{x+2} - 5$ can be obtained from the graph of $y = \sqrt{x}$. 14. _____
- Translate 2 unit to the right and 5 units up.
 - Translate 2 unit to the right and 5 units down.
 - Translate 2 unit to the left and 5 units up.
 - Translate 2 unit to the left and 5 units down.

15. Determine the symmetries of the graph of the relation $x^2 - 2xy + y^2 = 5$. 15. _____
- x -axis only
 - y -axis only
 - origin only
 - x -axis, y -axis, and origin

Given $f(x) = 5x - 4$ and $g(x) = x^2 + 3$, find each of the following.
Simplify the expressions when possible.

16. $(g - f)(x)$ 16. _____
- $x^2 - 5x + 7$
 - $x^2 + 5x - 7$
 - $-x^2 - 5x + 1$
 - $x^2 + 5x + 1$

17. $(fg)(x)$ 17. _____
- $x^3 + 4x^2 - 12$
 - $5x^3 - 4x^2 + 15x - 12$
 - $5x^3 + 4x^2 + 3x - 12$
 - $-5x^3 + 4x^2 - 5x - 12$

18. The domain of $\frac{g}{f}$ 18. _____
- $\left(-\infty, \frac{4}{5} \right) \cup \left(\frac{4}{5}, \infty \right)$
 - $\left(-\infty, \frac{5}{4} \right) \cup \left(\frac{5}{4}, \infty \right)$
 - $\left(-\infty, \frac{1}{3} \right) \cup \left(\frac{1}{3}, \infty \right)$
 - $(-\infty, \infty)$

19. $\frac{f(x+h) - f(x)}{h}$ 19. _____
- h
 - 5
 - $5x + 2h$
 - $5x + 2h - 4$

20. $(f + g)(-1)$ 20. _____
- -1
 - -5
 - 2
 - 5

CHAPTER 2, FORM E

21. $\left| \begin{array}{c} f \\ g \end{array} \right| (0)$

a. $-\frac{3}{4}$

c. $-\frac{4}{3}$

b. $\frac{1}{4}$

d. $\frac{15}{2}$

21. _____

22. $(g \circ f)(x)$

a. $25x^2 + 40x - 19$

c. $25x^2 - 40x - 19$

b. $25x^2 - 40x + 19$

d. $25x^2 + 40x + 19$

22. _____

23. $(g \circ f)(1)$

a. -6

c. 0

b. 4

d. 1

23. _____

24. $(f \circ g)(x)$

a. $5x^2 - 11$

c. $5x^2 + 19$

b. $5x^2 + 11$

d. $5x^2 - 12$

24. _____

25. $(g \circ f)(0)$

a. -1

c. 19

b. 0

d. 15

25. _____

**CHAPTER 2, FORM F
COLLEGE ALGEBRA**

NAME _____
DATE _____

Choose the best answer.

- 1a.** Which of the following is the domain of $f(x) = \sqrt{x-1}$? **1a.** _____
- a. $[0, 1]$ b. $(-\infty, 1]$
c. $[1, \infty)$ d. $(-\infty, \infty)$
- 1b.** Which of the following is the range of $f(x) = x^2 - 16$? **1b.** _____
- a. $[-16, \infty)$ b. $[-4, \infty)$
c. $[-4, 4]$ d. $[0, \infty)$
- 1c.** Which of the following is the domain of $f(x) = \sqrt[3]{x-7}$? **1c.** _____
- a. $(-\infty, \infty)$ b. $(-\infty, 3]$
c. $[0, \infty)$ d. $[3, \infty)$
- 1d.** Which of the following is the range of $f(x) = |x-3|$? **1d.** _____
- a. $[-2, 2]$ b. $[0, 2]$
c. $[2, \infty)$ d. $[0, \infty)$
- 1e.** Which of the following is the domain of $x = y^2$? **1e.** _____
- a. $(-\infty, \infty)$ b. $[0, \infty)$
c. $(0, \infty)$ d. $(-\infty, 0]$

The graph shows the line that passes through $(-7, -4)$ and $(3, -2)$. Refer to it to answer Exercises 2-6.

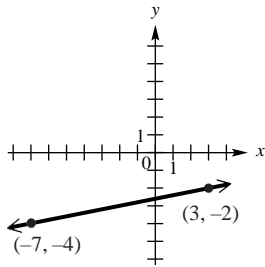

- 2.** What is the slope of the line? **2.** _____
- a. 0 b. $-\frac{1}{5}$
c. $\frac{1}{5}$ d. 5
- 3.** What is the distance between the two points shown? **3.** _____
- a. $\sqrt{122}$ b. $2\sqrt{26}$
c. $2\sqrt{13}$ d. $2\sqrt{34}$

CHAPTER 2, FORM F

4. What are the coordinates of the midpoint of the segment joining the two points?

a. $\left(\frac{1}{2}, -\frac{11}{2}\right)$ b. $(-2, -1)$
 c. $(-5, -1)$ d. $(-2, -3)$

4. _____

5. Find the standard form of the equation of the line.

a. $5x - y = 17$ b. $5x + y = -17$
 c. $x - 5y = 13$ d. $x + 5y = -13$

5. _____

6. Write the linear function $f(x) = ax + b$ that has this line as its graph.

a. $f(x) = \frac{1}{5}x - \frac{13}{5}$ b. $f(x) = -5x + 17$
 c. $f(x) = 5x - 17$ d. $f(x) = \frac{1}{5}x + \frac{13}{5}$

6. _____

Tell whether each graph is that of a function. Give the domain and range.

7.

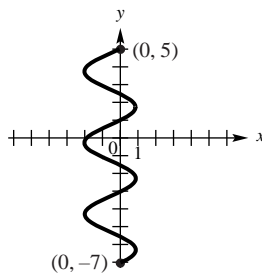

7. _____

- a. not a function; domain: $[-2, 1]$; range: $(-\infty, \infty)$
 b. not a function; domain: $[-7, 5]$; range: $[-2, 1]$
 c. not a function; domain: $[-7, 5]$; range: $(-\infty, \infty)$
 d. not a function; domain: $[-2, 1]$; range: $[-7, 5]$

8.

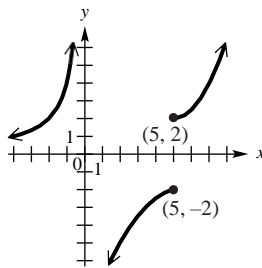

8. _____

- a. not a function; domain: $(-\infty, 0) \cup (0, \infty)$; range: $(-\infty, -2] \cup (0, \infty)$
 b. not a function; domain: $(-\infty, \infty)$; range: $(-\infty, \infty)$
 c. not a function; domain: $(-\infty, 0) \cup (0, \infty)$; range: $(-\infty, \infty)$
 d. not a function; domain: $(-\infty, 0) \cup (0, \infty)$; range: $(-\infty, -2] \cup [2, \infty)$

CHAPTER 2, FORM F

9. Suppose point P has coordinates $(-3, 6)$.
What is the equation of the horizontal line through P ?

- a. $x = -3$ b. $y = -3$
c. $x = 6$ d. $y = 6$

9. _____

10. Find the slope-intercept form of the equation of the line passing through $(1, 2)$ and parallel to the graph of $y = -\frac{1}{8}x + \frac{1}{3}$

10. _____

- a. $y = 8x - 3$ b. $y = \frac{1}{8}x - \frac{1}{3}$
c. $y = -8x + 3$ d. $y = -\frac{1}{8}x + \frac{17}{8}$

Graph each relation.

11. $f(x) = \frac{1}{2}|x-1|$

11. _____

a.

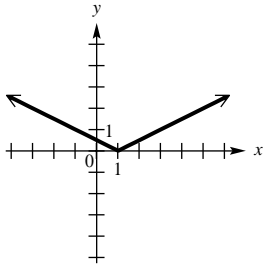

b.

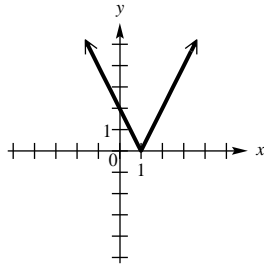

c.

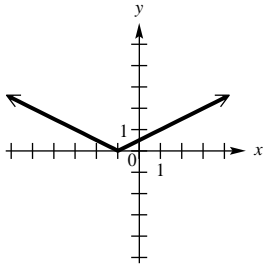

d.

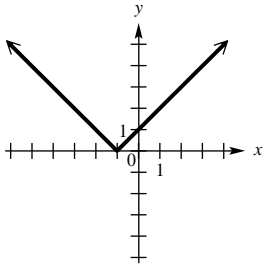

CHAPTER 2, FORM F

12. $f(x) = \begin{cases} \frac{1}{2}x + 1 & x < 1 \\ \frac{1}{2}x & x \geq 1 \end{cases} - 2$

12. _____

a.

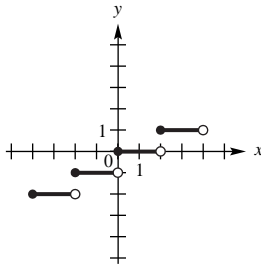

b.

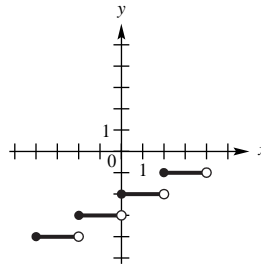

c.

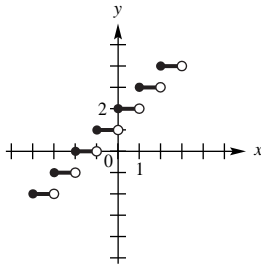

d.

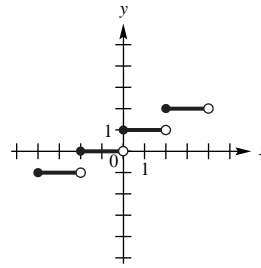

13. $f(x) = \begin{cases} -2x & \text{if } x < -1 \\ x + 3 & \text{if } x \geq -1 \end{cases}$

13. _____

a.

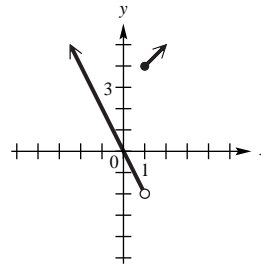

b.

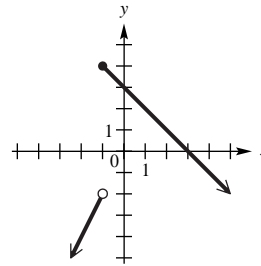

c.

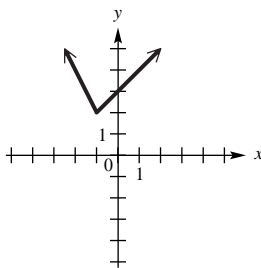

d.

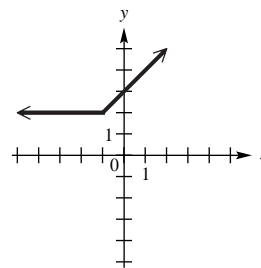
14. Explain how the graph of $y = \sqrt{x+3} + 1$ can be obtained from the graph of $y = \sqrt{x}$.

14. _____

- Translate 3 units to the right and 1 units up.
- Translate 3 units to the right and 1 units down.
- Translate 3 units to the left and 1 units up.
- Translate 3 units to the left and 1 units down.

CHAPTER 2, FORM F

15. Determine the symmetries of the graph of the relation $4x^2 + 9y^2 = 36$.

- a. x -axis only b. y -axis only
 c. Origin only d. x -axis, y -axis, and origin

15. _____

Given $f(x) = 6x^2 + 5x - 6$ and $g(x) = 2x - 8$, find each of the following.
 Simplify the expressions when possible.

16. $f(-3)$

- a. -9 b. 21
 c. 33 d. 51

16. _____

17. $\frac{f(x+h) - f(x)}{h}$

- a. $12x + 6h + 5$ b. $12x - 6h - 5$
 c. $-12x - 6h + 5$ d. $-12x + 6h - 5$

17. _____

18. $(f \circ g)\left(\frac{3}{2}\right)$

- a. -131 b. 119
 c. -181 d. 169

18. _____

19. $(f - g)(x)$

- a. $6x^2 + 7x + 2$ b. $-6x^2 + 7x - 2$
 c. $6x^2 + 3x + 2$ d. $-6x^2 - 3x - 2$

19. _____

20. $(f + g)(1)$

- a. -15 b. -1
 c. -27 d. 1

20. _____