

Finite Mathematics for Business Economics Life Sciences and Social Sciences 13th Edition

**Test Bank for Finite Mathematics for Business Economics Life Sciences and Social
Sciences 13th Edition by Barnett Ziegler and Byleen ISBN 0321945522 9780321945525**

Full link download:

Test Bank:

<https://testbankpack.com/p/test-bank-for-finite-mathematics-for-business-economics-life-sciences-and-social-sciences-13th-edition-by-barnett-ziegler-and-byleen-isbn-0321945522-9780321945525/>

Solution Manual:

<https://testbankpack.com/p/solution-manual-for-finite-mathematics-for-business-economics-life-sciences-and-social-sciences-13th-edition-by-barnett-ziegler-and-byleen-isbn-0321945522-9780321945525/>

MULTIPLE CHOICE. Choose the one alternative that best completes the statement or answers the question.

Use point-by-point plotting to sketch the graph of the equation.

1) $y = x + 2$

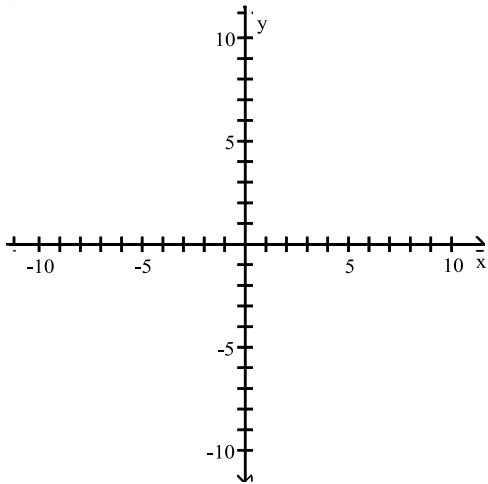

A)

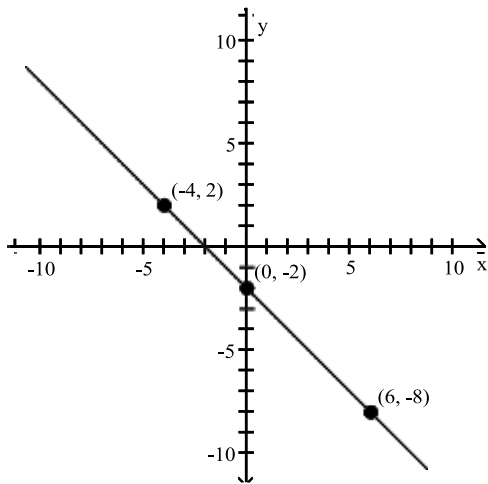

B)

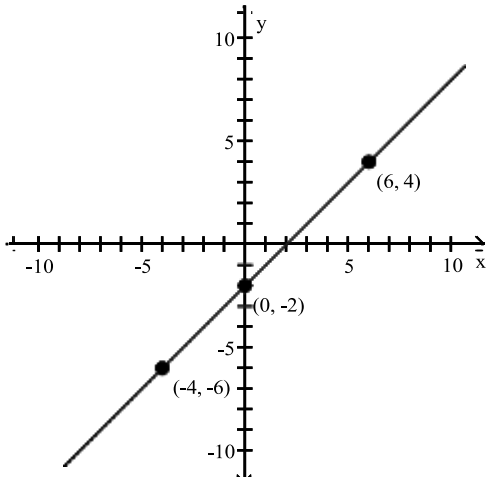

C)

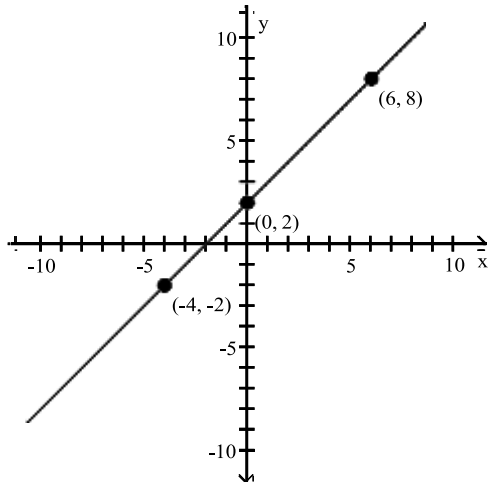

D)

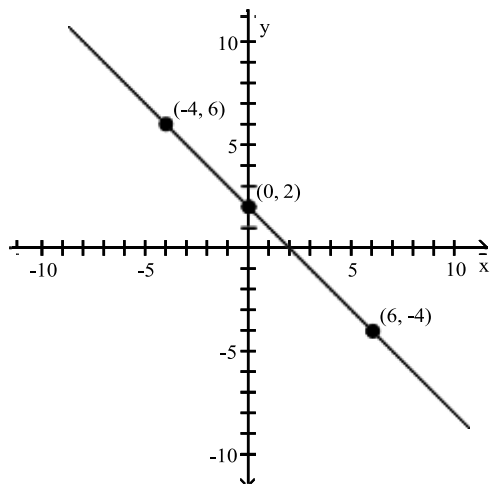

Answer: C

2) $y = x^2 + 4$

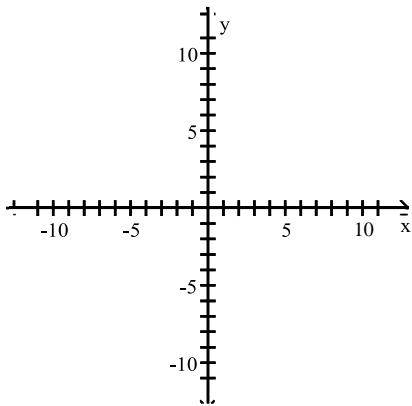

A)

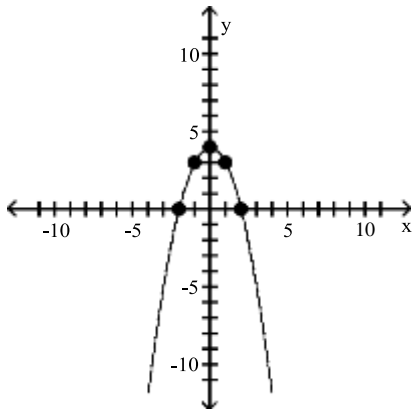

B)

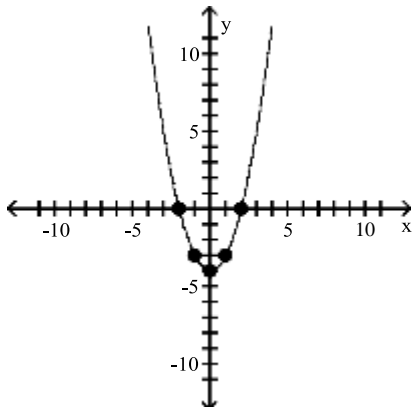

C)

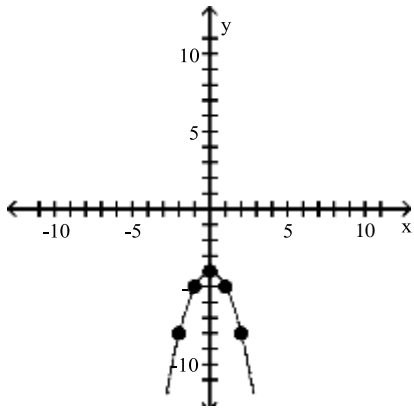

D)

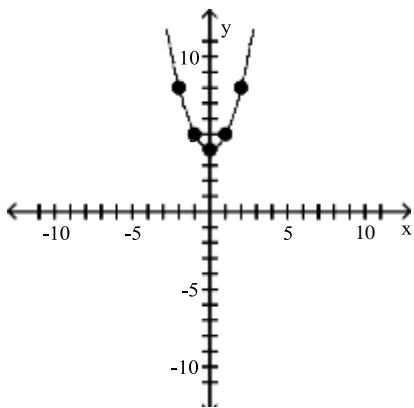

Answer: D

Determine whether the graph is the graph of a function.

3)

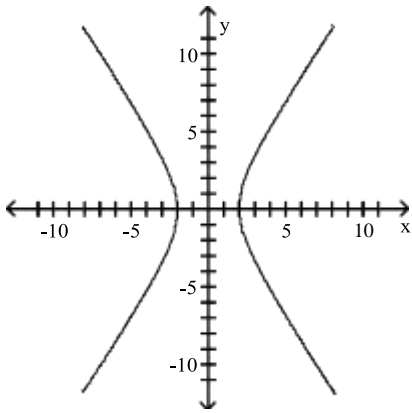

- A) function
- B) not a function

Answer: B

4)

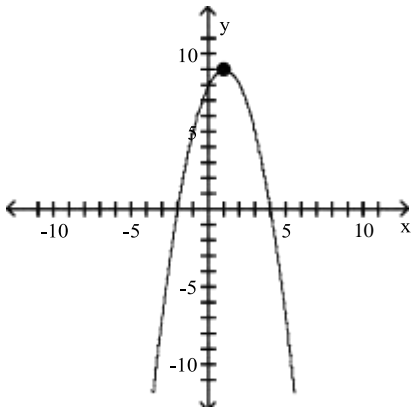

- A) function
- B) not a function

Answer: A

5)

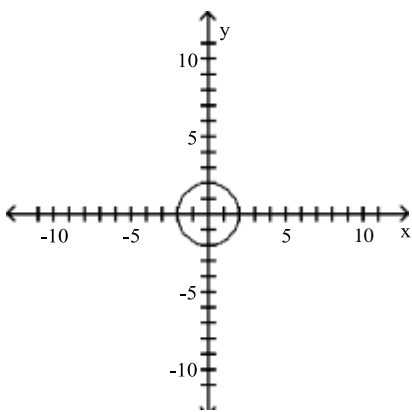

- A) function
- B) not a function

Answer: B

Determine whether the relation represents a function. If it is a function, state the domain and range.

6)

4	→	20
9	→	45
14	→	70
19	→	95

A) function

domain: {4, 9, 14, 19}

range: {20, 45, 70, 95}

B) function

domain: {20, 45, 70, 95}

range: {4, 9, 14, 19}

C) not a function

Answer: A

7)

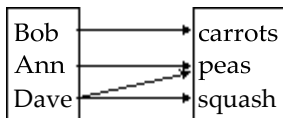

A) function

domain: {Bob, Ann, Dave}

range: {carrots, peas, squash}

B) function

domain: {carrots, peas, squash}

range: {Bob, Ann, Dave}

C) not a function

Answer: C

8) {(19, -2), (3, -1), (3, 0), (4, 1), (12, 3)}

A) function

domain: {-2, -1, 0, 1, 3}

range: {19, 4, 3, 12}

B) function

domain: {19, 4, 3, 12}

range: {-2, -1, 0, 1, 3}

C) not a function

Answer: C

9) {(-4, 21), (-3, 14), (0, 5), (3, 14), (5, 30)}

A) function

domain: {-4, -3, 0, 3, 5}

range: {21, 14, 5, 30}

B) function

domain: {21, 14, 5, 30}

range: {-4, -3, 0, 3, 5}

C) not a function

Answer: A

Determine whether the function is linear, constant, or neither

$$10) y = \frac{x+3}{7}$$

- A) Linear
- B) Constant
- C) Neither

Answer: A

$$11) y = x^3 - x^2 + 8$$

- A) Linear
- B) Constant
- C) Neither

Answer: C

$$12) y = \frac{2\pi}{3}$$

- A) Linear
- B) Constant
- C) Neither

Answer: B

$$13) y - 12 = 0$$

- A) Linear
- B) Constant
- C) Neither

Answer: B

Use point-by-point plotting to sketch the graph of the equation.

$$14) f(x) = \frac{2x}{x-1}$$

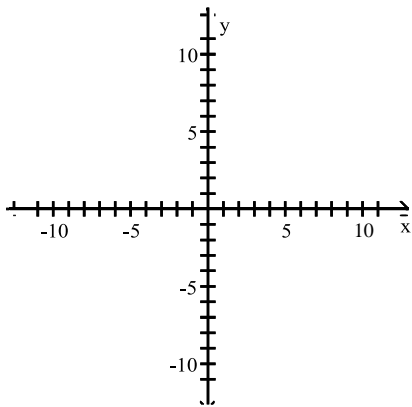

A)

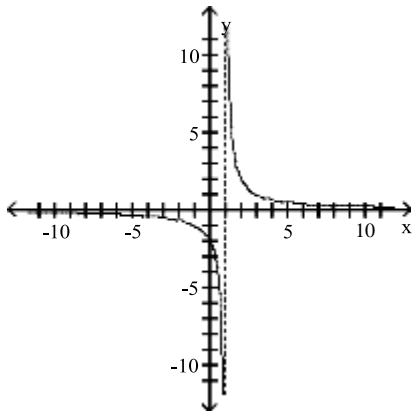

B)

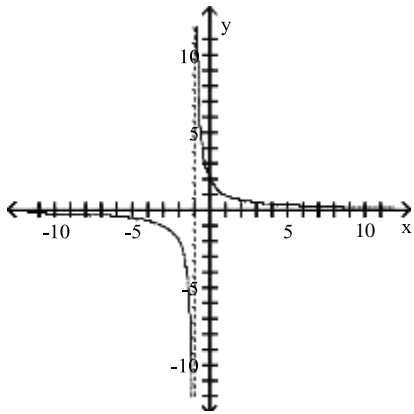

C)

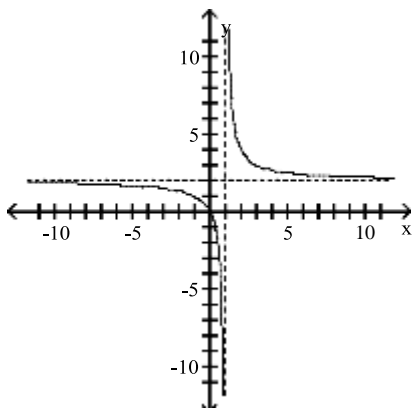

D)

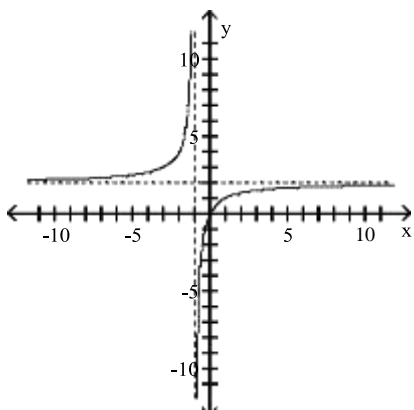

Answer: C

The graph of a function f is given. Use the graph to answer the question.

15) Use the graph of f given below to find $f(2)$.

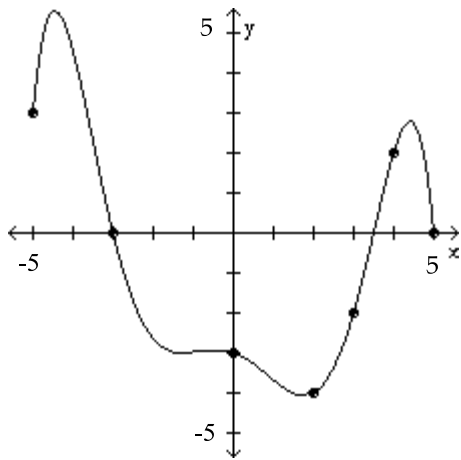

- A) 3
- B) 2
- C) -4
- D) 0

Answer: C

Find the function value.

16) Find $f(4)$ when $f(x) = 5 - 8x^2$.

- A) -27
- B) -123
- C) 133
- D) -59

Answer: B

17) $f(x) = \frac{x^2 - 2}{x^3 - 7x}$; $f(5)$

- A) $\frac{23}{118}$
- B) $\frac{5}{18}$
- C) $\frac{23}{90}$
- D) $\frac{23}{125}$

Answer: C

18) Given that $f(x) = 5x^2 - 2x$, find $f(t + 2)$.

- A) $t^2 + 2t - 6$
- B) $3t + 6$
- C) $5t^2 - 18t + 16$
- D) $5t^2 + 18t + 16$

Answer: D

SHORT ANSWER. Write the word or phrase that best completes each statement or answers the question.

Provide an appropriate response.

19) If $g(x) = -4x^2 + x - 9$, find $g(-2)$, $g(1)$, and $g\left(\frac{3}{2}\right)$.

Answer: -27, -12, - $\frac{33}{2}$

20) For $f(t) = 3t + 2$ and $g(t) = 2 - t^2$, find $4f(3) - g(-3) + g(0)$.

Answer: 53

21) For $f(t) = 3 - 5t$, find $\frac{f(a+h) - f(a)}{h}$.

Answer: -5

MULTIPLE CHOICE. Choose the one alternative that best completes the statement or answers the question.

Compute and simplify the difference quotient $\frac{f(x+h) - f(x)}{h}$, $h \neq 0$.

22) $f(x) = 5x^2 + 7x$

- A) $10x^2 + 5h + 7x$
- B) $10x + 5h + 7$
- C) $15x - 7h + 14$
- D) $10x + 7$

Answer: B

Determine the domain of the function.

23) $f(x) = -7x + 9$

- A) All real numbers except $\frac{9}{7}$
- B) No solution
- C) All real numbers
- D) $x \leq \frac{9}{7}$

Answer: C

$$24) f(x) = \frac{x}{x-2}$$

- A) All real numbers
- B) All real numbers except 2
- C) $x < 2$
- D) No solution

Answer: B

$$25) f(x) = \sqrt{3-x}$$

- A) No solution
- B) $x < 3$
- C) All real numbers except 3
- D) $x \leq 3$

Answer: D

$$26) f(x) = \frac{8}{x^3}$$

- A) No solution
- B) All real numbers except 0
- C) $x < 0$
- D) All real numbers

Answer: B

SHORT ANSWER. Write the word or phrase that best completes each statement or answers the question.

Provide an appropriate response.

27) Only one of the following functions has domain which is not equal to all real numbers. State which function and state its domain.

$$(A) h(x) = 4x^2 - 3x - 5 \quad (B) f(x) = \frac{2x}{48-x} \quad (C) g(x) = \frac{x+7}{2}$$

Answer: $f(x) = \frac{2x}{48-x}$ has domain all real numbers except $x = 48$.

MULTIPLE CHOICE. Choose the one alternative that best completes the statement or answers the question.

Determine if the equation specifies a function with independent variable x . If so, find the domain. If not, find a value of x to which there corresponds more than one value of y .

$$28) x - y^2 = 9$$

- A) A function with domain \mathcal{R}
- B) Not a function; for example, when $x = 10$, $y = \pm 1$

Answer: B

$$29) y = x^2 + 8$$

- A) A function with domain \mathcal{R}
- B) Not a function; for example, when $x = 8$, then $y = \pm 1$

Answer: A

- 30) $xy = -1$
A) A function with domain all real numbers except $x = 0$
B) Not a function; for example, when $x = -1$, $y = \pm 1$

Answer: A

- 31) $xy + 3y = -8$
A) A function with domain all real numbers except $x = -3$
B) Not a function; for example, when $x = -8$, $y = \pm 3$

Answer: A

- 32) $x^2 + y^2 = 9$
A) A function with domain \mathcal{R}
B) Not a function; for example, when $x = 0$, $y = \pm 3$

Answer: B

- 33) $x^2 - y^2 = 9$
A) A function with domain all real numbers except $x = 5$
B) Not a function; for example, when $x = 5$, $y = \pm 4$

Answer: B

Solve the problem.

- 34) The function F described by $F(x) = 2.75x + 71.48$ can be used to estimate the height, in centimeters, of a woman whose humerus (the bone from the elbow to the shoulder) is x cm long. Estimate the height of a woman whose humerus is 30.93 cm long. Round your answer to the nearest four decimal places.
A) 156.5375 cm
B) 43.3000 cm
C) 105.1600 cm
D) 13.5775 cm

Answer: A

- 35) The function M described by $M(x) = 2.89x + 70.64$ can be used to estimate the height, in centimeters, of a male whose humerus (the bone from the elbow to the shoulder) is x cm long. Estimate the height of a male whose humerus is 30.93 cm long. Round your answer to the nearest four decimal places.
A) 156.5375 cm
B) 160.0277 cm
C) 157.3400 m
D) 30.9300 cm

Answer: B

- 36) To estimate the ideal minimum weight of a woman in pounds multiply her height in inches by 4 and subtract 130. Let W = the ideal minimum weight and h = height. W is a linear function of h . Find the ideal minimum weight of a woman whose height is 62 inches.
A) 118 lb
B) 378 lb
C) 120 lb
D) 130 lb

Answer: A

- 37) The point at which a company's costs equals its revenue is the break-even. C represents cost, in dollars, of x units of a product. R represents the revenue, in dollars, for the sale of x units. Find the number of units that must be produced and sold in order to break even.

$$C = 15x + 12,000$$

$$R = 18x - 6000$$

- A) 12,000
- B) 545
- C) 6000
- D) 800

Answer: C

- 38) The function P , given by $P(d) = \frac{1}{33}d + 1$, gives the pressure, in atmospheres (atm), at a depth d , in feet, under

the sea. Find the pressure at 200 feet. Round your answer to the nearest whole number.

- A) 7 atm
- B) 200 atm
- C) 8 atm
- D) 201 atm

Answer: A

- 39) To estimate the ideal minimum weight of a woman in pounds multiply her height in inches by 4 and subtract 130. Let W = the ideal minimum weight and h = height. Express W as a linear function of h .

- A) $W(h) = 130h + 4$
- B) $W(h) = 4(h + 130)$
- C) $W(h) = 130$
- D) $W(h) = 4h - 130$

Answer: D

Provide an appropriate response.

- 40) In a profit-loss analysis, point where revenue equals cost.

- A) break-even point
- B) turning point
- C) inflection point
- D) profit-loss point

Answer: A

SHORT ANSWER. Write the word or phrase that best completes each statement or answers the question.

- 41) Let T be the set of teachers at a high school and let S be the set of students enrolled at that school. Determine which of the following correspondences define a function. Explain.

- (A) A student corresponds to the teacher if the student is enrolled in the teacher's class.
- (B) A student corresponds to every teacher of the school.

Answer: Choice (A) defines a function. To each element (student) of the first set (or domain), there corresponds exactly one element (teacher) of the second set (or range).

Choice (B) does not define a function. An element (student) of the first set (or domain) corresponds to more than one element (teacher) of the second set (or range).

MULTIPLE CHOICE. Choose the one alternative that best completes the statement or answers the question.

Give the domain and range of the function.

42) $f(x) = x^2 + 6$

- A) Domain: all real numbers; Range: $[-2, \infty)$
- B) Domain: $[0, \infty)$; Range: $[0, \infty)$
- C) Domain: all real numbers; Range: $[6, \infty)$
- D) Domain: $[6, \infty)$; Range: all real numbers

Answer: C

43) $g(x) = x^2 - 6$

- A) Domain: $[0, \infty)$; Range: $[0, \infty)$
- B) Domain: all real numbers; Range: $[2, \infty)$
- C) Domain: all real numbers; Range: $[-6, \infty)$
- D) Domain: $[6, \infty)$; Range: all real numbers

Answer: C

44) $h(x) = -6|x|$

- A) Domain: $(-\infty, 0]$; Range: all real numbers
- B) Domain: all real numbers; Range: $(-\infty, 3]$ C)
- Domain: $[0, \infty)$; Range: $[0, \infty)$
- D) Domain: all real numbers; Range: $(-\infty, 0]$

Answer: D

45) $s(x) = \sqrt{-5 - x}$

- A) Domain: $(\sqrt{5}, \infty)$; Range: $(-\infty, 0]$
- B) Domain: $(-\infty, -5]$; Range: $[0, \infty)$
- C) Domain: $(-\infty, -5) \cup (-5, \infty)$; Range: $(-\infty, 0) \cup (0, \infty)$
- D) Domain: all real numbers; Range: $[0, \infty)$

Answer: B

46) $r(x) = |x - 2| - 9$

- A) Domain: all real numbers; Range: $[0, \infty)$
- B) Domain: all real numbers; Range: all real numbers
- C) Domain: all real numbers; Range: $[-9, \infty)$
- D) Domain: $[-9, \infty)$; Range: all real numbers

Answer: C

Provide an appropriate response.

47) How can the graph of $f(x) = -\sqrt{x + 1}$ be obtained from the graph of $y = \sqrt{x}$?

- A) Shift it horizontally -1 units to the left. Reflect it across the x-axis.
- B) Shift it horizontally 1 units to the right. Reflect it across the x-axis.
- C) Shift it horizontally 1 units to the left. Reflect it across the y-axis.
- D) Shift it horizontally 1 units to the left. Reflect it across the x-axis.

Answer: D

- 48) How can the graph of $f(x) = -(x - 1)^2 - 6$ be obtained from the graph of $y = x^2$?
- A) Shift it horizontally 1 units to the left. Reflect it across the x-axis. Shift it 6 units up.
 - B) Shift it horizontally 1 units to the right. Reflect it across the y-axis. Shift it 6 units down.
 - C) Shift it horizontally 1 units to the right. Reflect it across the y-axis. Shift it 6 units up.
 - D) Shift it horizontally 1 units to the right. Reflect it across the x-axis. Shift it 6 units up.

Answer: D

Write an equation for a function that has a graph with the given transformations.

- 49) The shape of $y = \sqrt{x}$ is shifted 5 units to the left. Then the graph is shifted 7 units upward.
- A) $f(x) = 7\sqrt{x + 5}$
 - B) $f(x) = \sqrt{x + 7} + 5$
 - C) $f(x) = \sqrt{x + 5} + 7$
 - D) $f(x) = \sqrt{x - 5} + 7$

Answer: C

- 50) The shape of $y = x^2$ is vertically stretched by a factor of 10, and the resulting graph is reflected across the x-axis.
- A) $f(x) = 10(x - 10)^2$
 - B) $f(x) = 10x^2$
 - C) $f(x) = -10x^2$
 - D) $f(x) = (x - 10)^2$

Answer: C

SHORT ANSWER. Write the word or phrase that best completes each statement or answers the question.

Provide an appropriate response.

- 51) The following graph represents the result of applying a sequence of transformations to the graph of a basic function. Identify the basic function and describe the transformation(s). Write the equation for the given graph.

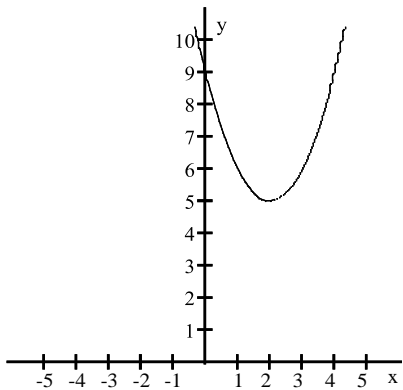

Answer: Basic function is $f(x) = x^2$; shift right 2 units, shift up 5 units. $f(x) = (x - 2)^2 + 5$

52) The following graph represents the result of applying a sequence of transformations to the graph of a basic function. Identify the basic function and describe the transformation(s). Write the equation for the given graph.

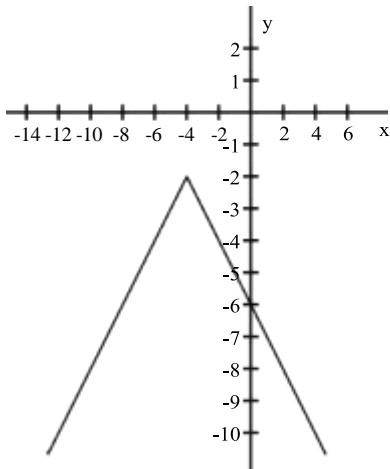

Answer: Basic function is $f(x) = |x|$; reflect over the x -axis, shift left 4 units, shift down 2 units. $f(x) = -|x + 4| - 2$

MULTIPLE CHOICE. Choose the one alternative that best completes the statement or answers the question.

Graph the function.

53)

$$f(x) = \begin{cases} x - 1 & \text{if } x < 1 \\ 4 & \text{if } x \geq 1 \end{cases}$$

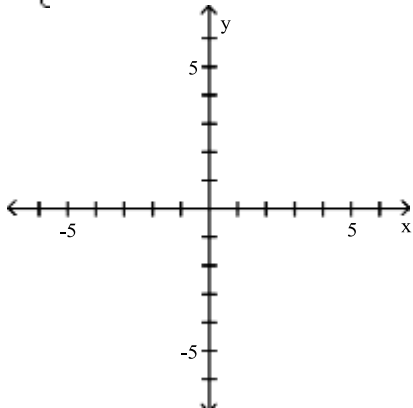

A)

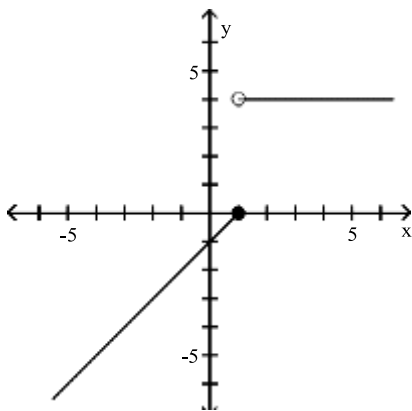

B)

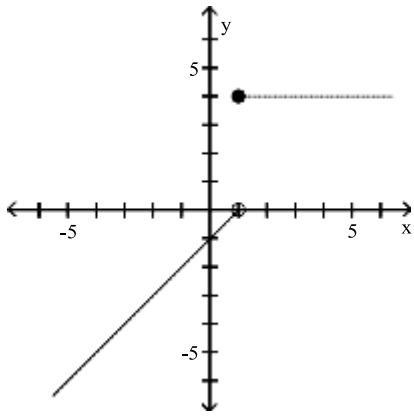

C)

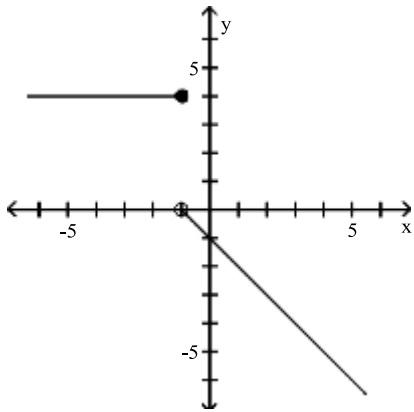

D)

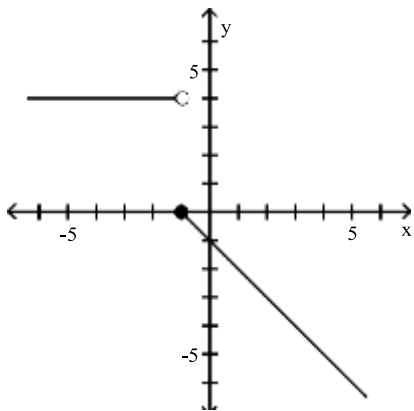

Answer: B

54)

$$f(x) = \begin{cases} -x + 3 & \text{if } x < 2 \\ 2x - 3 & \text{if } x \geq 2 \end{cases}$$

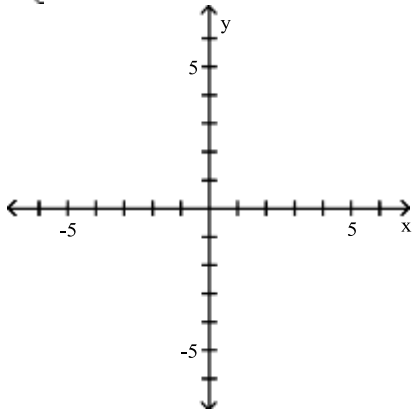

A)

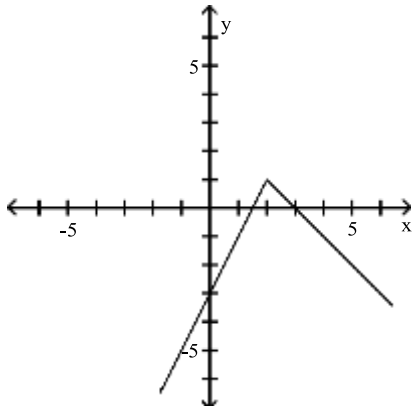

B)

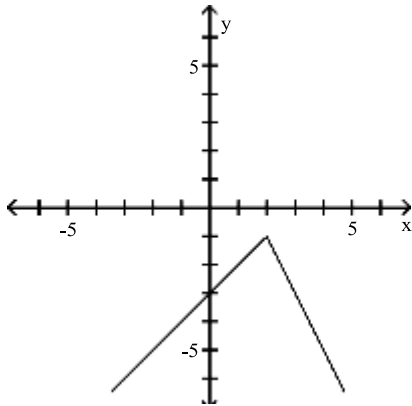

C)

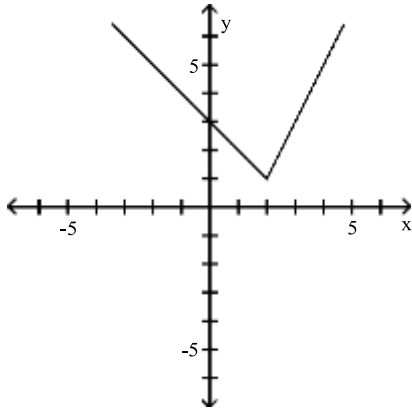

D)

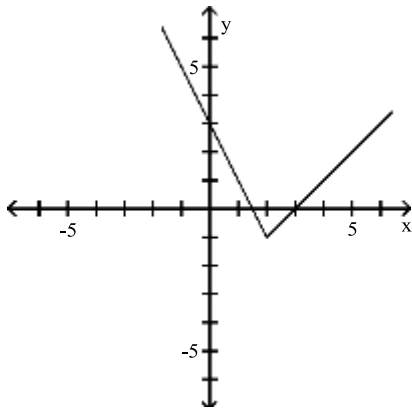

Answer: C

55) Assume it costs 25 cents to mail a letter weighing one ounce or less, and then 20 cents for each additional ounce or fraction of an ounce. Let $L(x)$ be the cost of mailing a letter weighing x ounces. Graph $y = L(x)$. Use the interval $(0, 4]$.

A)

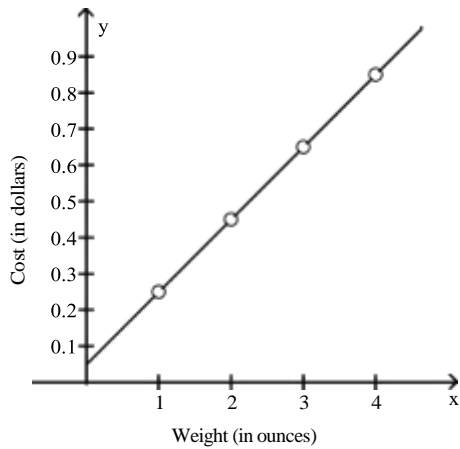

B)

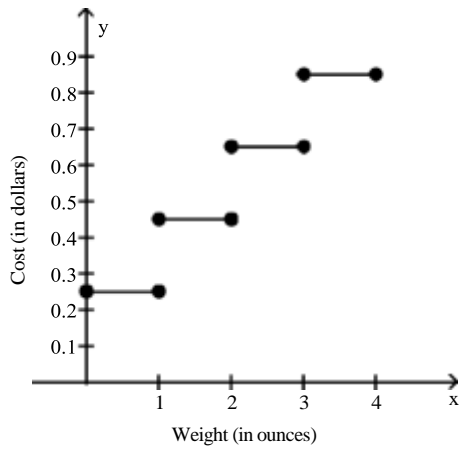

C)

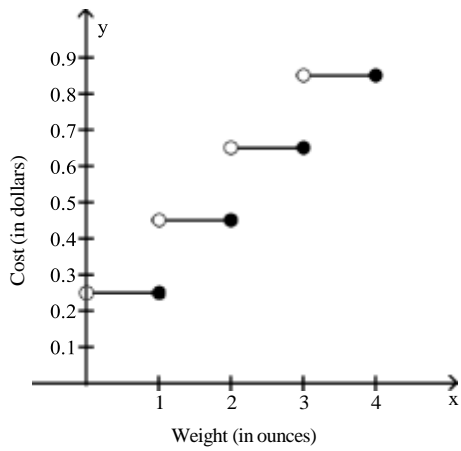

D)

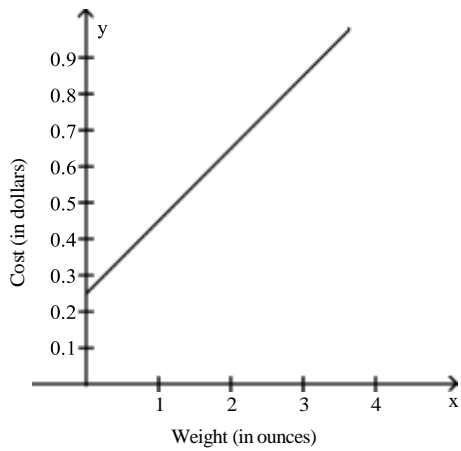

Answer: C

SHORT ANSWER. Write the word or phrase that best completes each statement or answers the question.

Provide an appropriate response.

56) If $f(x) = \begin{cases} x - 3 & \text{if } x < 2 \\ x^2 & \text{if } x \geq 2 \end{cases}$, what is the definition of $g(x)$, the function whose graph is obtained by shifting $f(x)$'s

graph right 5 units and down 1 unit?

Answer: $g(x) = \begin{cases} x - 9 & x < 7 \\ (x - 5)^2 - 1 & x \geq 7 \end{cases}$

MULTIPLE CHOICE. Choose the one alternative that best completes the statement or answers the question.

Solve the problem.

57) A retail chain sells washing machines. The retail price $p(x)$ (in dollars) and the weekly demand x for a particular model are related by the function $p(x) = 625 - 5\sqrt{x}$, where $50 \leq x \leq 500$. (i) Describe how the graph of the function p can be obtained from the graph of one of the six basic functions: $y = x$, $y = x^2$, $y = x^3$, $y = \sqrt{x}$, $y = \sqrt[3]{x}$, or $y = |x|$. (ii) Sketch a graph of function p using part (i) as an aid.

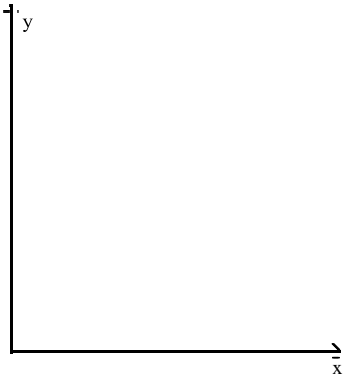

A) (i) The graph of the basic function $y = \sqrt{x}$ is reflected in the x -axis and vertically expanded by a factor of 5.

(ii)

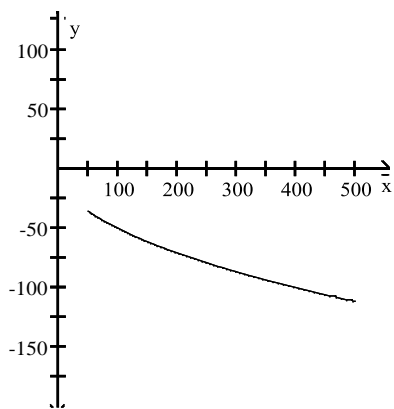

B) (i) The graph of the basic function $y = \sqrt{x}$ is reflected in the x-axis, vertically expanded by a factor of 5, and shifted up 625 units.

(ii)

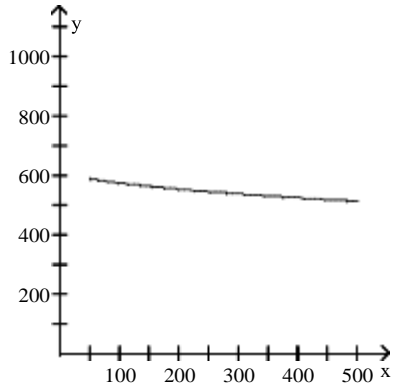

C) (i) The graph of the basic function $y = \sqrt{x}$ is vertically expanded by a factor of 5, and shifted up 625 units.

(ii)

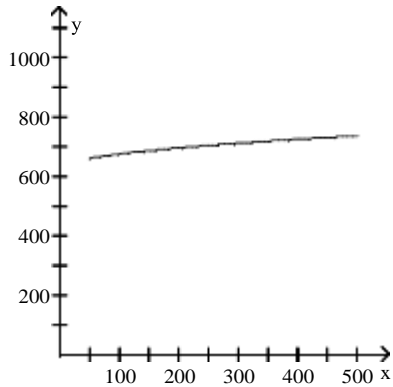

D) (i) The graph of the basic function $y = \sqrt{x}$ is vertically expanded by a factor of 625, and shifted up 5 units.

(ii)

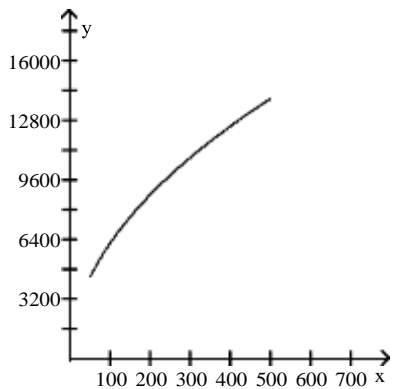

Answer: B

58) The following table shows a recent state income tax schedule for married couples filing a joint return in State X.

State X Income Tax

SCHEDULE I - MARRIED FILING JOINTLY

If taxable income is	But not over	Tax due is
Over \$0	\$40,000	4.25% of taxable incomes
\$40,000	\$70,000	\$3700 plus 6.75% of excess over \$40,000
\$70,000		\$3875 plus 7.05% of excess over \$70,000

(i) Write a piecewise definition for the tax due $T(x)$ on an income of x dollars. (ii) Graph $T(x)$. (iii) Find the tax due on a taxable income of \$50,000. Of \$95,000.

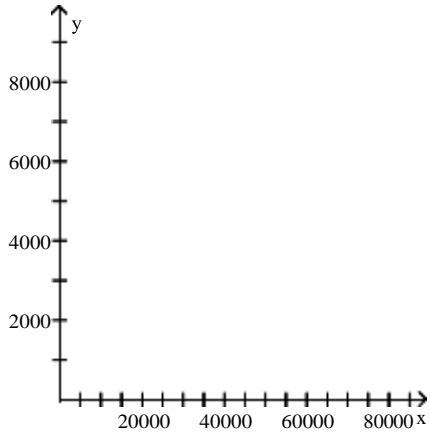

A) (i)

$$T(x) = \begin{cases} 0.0425x & \text{if } 0 \leq x \leq 40,000 \\ 0.0675x - 1025 & \text{if } 40,000 < x \leq 70,000 \\ 0.0705x - 1375 & \text{if } x > 70,000 \end{cases}$$

(ii)

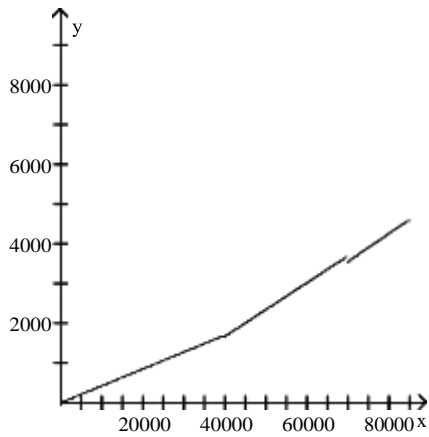

(iii) \$2350; \$5322.50

B) (i)

$$T(x) = \begin{cases} 0.0425x & \text{if } 0 \leq x \leq 40,000 \\ 0.0675x - 1000 & \text{if } 40,000 < x \leq 70,000 \\ 0.0705x - 1060 & \text{if } x > 70,000 \end{cases}$$

(ii)

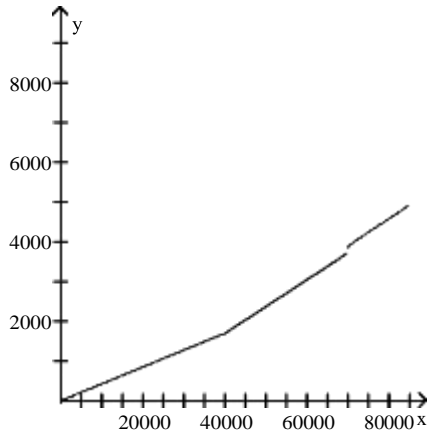

(iii) \$2375; \$5637.50

C) (i)

$$T(x) = \begin{cases} 0.0425x & \text{if } 0 \leq x \leq 40,000 \\ 0.0675x - 1300 & \text{if } 40,000 < x \leq 70,000 \\ 0.0705x - 1427 & \text{if } x > 70,000 \end{cases}$$

(ii)

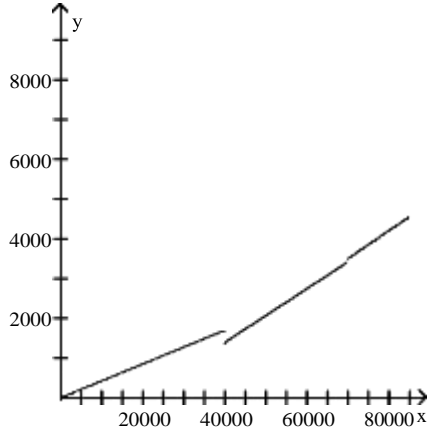

(iii) \$2075; \$5270.50

D) (i)

$$T(x) = \begin{cases} 0.0425x & \text{if } 0 \leq x \leq 40,000 \\ 0.0675x - 990 & \text{if } 40,000 < x \leq 70,000 \\ 0.0705x - 1000 & \text{if } x > 70,000 \end{cases}$$

(ii)

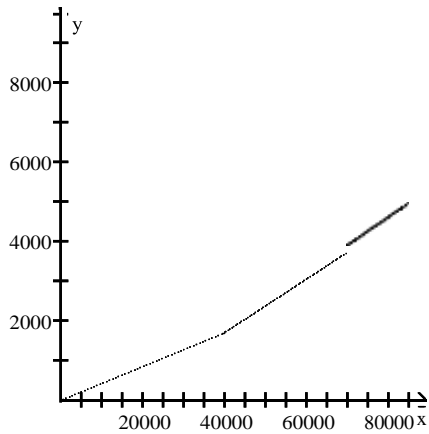

(iii) \$2385; \$5697.50

Answer: B

- 59) The average weight of a particular species of frog is given by $w(x) = 98x^3$, $0.1 \leq x \leq 0.3$, where x is length (with legs stretched out) in meters and $w(x)$ is weight in grams. (i) Describe how the graph of function w can be obtained from one of the six basic functions: $y = x$, $y = x^2$, $y = x^3$, $y = \sqrt{x}$, $y = \sqrt[3]{x}$, or $y = |x|$. (ii) Sketch a graph of function w using part (i) as an aid.

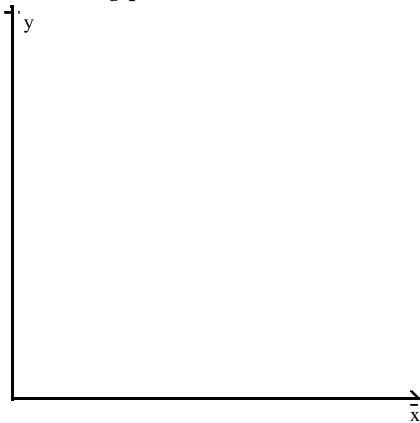

A) (i) The graph of the basic function $y = x^3$ is vertically expanded by a factor of 98.

(ii)

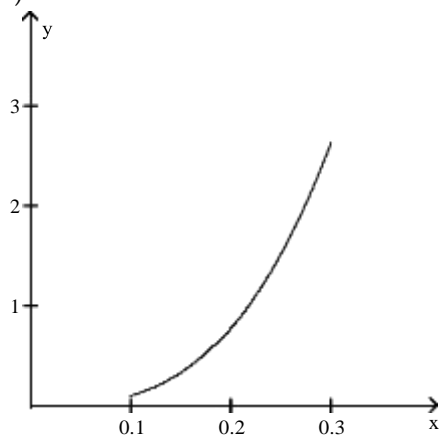

B) (i) The graph of the basic function $y = \sqrt[3]{x}$ is vertically expanded by a factor of 98.

(ii)

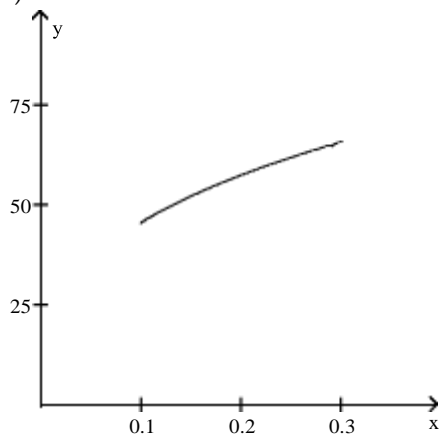

C) (i) The graph of the basic function $y = x^3$ is reflected on the x-axis and is vertically expanded by a factor of 98.

(ii)

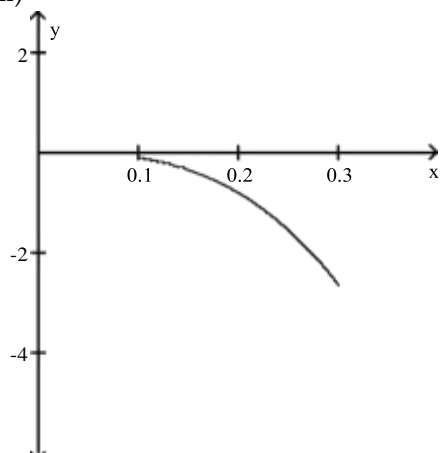

D) (i) The graph of the basic function $y = x^2$ is vertically expanded by a factor of 98.

(ii)

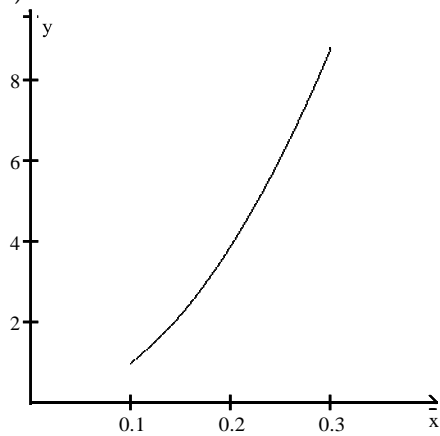

Answer: A

Find the x-intercept(s) if they exist.

60) $x^2 + 6x + 5 = 0$

A) 1, 5

B) $\sqrt{5}$, $-\sqrt{5}$

C) -1, -5

D) 10, -5

Answer: C

61) $6x^2 = 42x$

A) 7

B) 21

C) 0, 7

D) 0

Answer: C

For the given function, find each of the following:

(A) Intercepts

(B) Vertex

(C) Maximum or minimum

(D) Range

62) $f(x) = (x + 3)^2 - 4$

- A) (A) x-intercepts: 1, 5; y-intercept: 5
(B) Vertex (-3, -4)
(C) Minimum: -4
(D) $y \geq -4$

- B) (A) x-intercepts: -5, -1; y-intercept: 5
(B) Vertex (-3, -4)
(C) Maximum: -4
(D) $y \leq -4$

- C) (A) x-intercepts: -5, -1; y-intercept: 5
(B) Vertex (-3, -4)
(C) Minimum: -4
(D) $y \geq -4$

- D) (A) x-intercepts: -5, -1; y-intercept: 5
(B) Vertex (3, -4)
(C) Minimum: -4
(D) $y \geq -4$

Answer: C

63) $g(x) = (x - 3)^2 - 4$

- A) (A) x-intercepts: -5, -1; y-intercept: 5
(B) Vertex (3, -4)
(C) Minimum: -4
(D) $y \geq -4$

- B) (A) x-intercepts: 1, 5; y-intercept: 5
(B) Vertex (3, -4)
(C) Maximum: -4
(D) $y \leq -4$

- C) (A) x-intercepts: 1, 5; y-intercept: 5
(B) Vertex (-3, -4)
(C) Minimum: -4
(D) $y \geq -4$

- D) (A) x-intercepts: 1, 5; y-intercept: 5
(B) Vertex (3, -4)
(C) Minimum: -4
(D) $y \geq -4$

Answer: D

64) $m(x) = -(x + 2)^2 + 9$

- A) (A) x-intercepts: - 5, 1; y-intercept: 5
(B) Vertex (-2, 9)
(C) Minimum: 9
(D) $y \geq 9$

- B) (A) x-intercepts: - 5, 1; y-intercept: 5
(B) Vertex (-2, 9)
(C) Maximum: 9
(D) $y \leq 9$

- C) (A) x-intercepts: - 5, 1; y-intercept: 5
(B) Vertex (2, -9)
(C) Maximum: 9
(D) $y \leq 9$

- D) (A) x-intercepts: -1, 5; y-intercept: 5
(B) Vertex (-2, 9)
(C) Maximum: 9
(D) $y \leq 9$

Answer: B

65) $n(x) = -(x - 1)^2 + 9$

- A) (A) x-intercepts: - 2, 4; y-intercept: 8
(B) Vertex (1, 9)
(C) Maximum: 9
(D) $y \leq 9$

- B) (A) x-intercepts: -4, 2; y-intercept: 8
(B) Vertex (1, 9)
(C) Maximum: 9
(D) $y \leq 9$

- C) (A) x-intercepts: - 2, 4; y-intercept: 8
(B) Vertex (1, 9)
(C) Minimum: 9
(D) $y \geq 9$

- D) (A) x-intercepts: - 2, 4; y-intercept: 8
(B) Vertex (-1, -9)
(C) Maximum: 9
(D) $y \leq 9$

Answer: A

Find the vertex form for the quadratic function. Then find each of the following:

(A) Intercepts

(B) Vertex

(C) Maximum or minimum

(D) Range

66) $f(x) = x^2 + 6x + 8$

A) Standard form: $f(x) = (x - 3)^2 - 1$

(A) x-intercepts: 2, 4; y-intercept: 8

(B) Vertex (-3, -1)

(C) Minimum: -1

(D) $y \geq -1$

B) Standard form: $f(x) = (x + 3)^2 - 1$

(A) x-intercepts: -4, -2; y-intercept: 8

(B) Vertex (3, -1)

(C) Minimum: -1

(D) $y \geq -1$

C) Standard form: $f(x) = (x - 3)^2 - 1$

(A) x-intercepts: -4, -2; y-intercept: 8

(B) Vertex (-3, -1)

(C) Maximum: -1

(D) $y \leq -1$

D) Standard form: $f(x) = (x + 3)^2 - 1$

(A) x-intercepts: -4, -2; y-intercept: 8

(B) Vertex (-3, -1)

(C) Minimum: -1

(D) $y \geq -1$

Answer: D

67) $g(x) = x^2 - 2x - 8$

- A) Standard form: $g(x) = (x + 1)^2 - 9$
(A) x-intercepts: -4, 2; y-intercept: -8
(B) Vertex (1, -9)
(C) Minimum: -9
(D) $y \geq -9$
- B) Standard form: $g(x) = (x - 1)^2 - 9$
(A) x-intercepts: -2, 4; y-intercept: -8
(B) Vertex (1, -9)
(C) Minimum: -9
(D) $y \geq -9$
- C) Standard form: $g(x) = (x + 1)^2 - 9$
(A) x-intercepts: -2, 4; y-intercept: -8
(B) Vertex (1, -9)
(C) Maximum: -9
(D) $y \leq -9$
- D) Standard form: $g(x) = (x - 1)^2 - 9$
(A) x-intercepts: -2, 4; y-intercept: -8
(B) Vertex (-1, -9)
(C) Minimum: -9
(D) $y \geq -9$

Answer: B

68) $m(x) = -x^2 - 6x - 8$

A) Standard form: $m(x) = -(x - 3)^2 + 1$

(A) x-intercepts: 2, 4; y-intercept: -8

(B) Vertex (-3, 1)

(C) Maximum: 1

(D) $y \leq 1$

B) Standard form: $m(x) = -(x - 3)^2 + 1$

(A) x-intercepts: -4, -2; y-intercept: -8

(B) Vertex (-3, 1)

(C) Minimum: 1

(D) $y \geq 1$

C) Standard form: $m(x) = -(x + 3)^2 + 1$

(A) x-intercepts: -4, -2; y-intercept: -8

(B) Vertex (3, -1)

(C) Maximum: 1

(D) $y \leq 1$

D) Standard form: $m(x) = -(x + 3)^2 + 1$

(A) x-intercepts: -4, -2; y-intercept: -8

(B) Vertex (-3, 1)

(C) Maximum: 1

(D) $y \leq 1$

Answer: D

69) $n(x) = -x^2 + 4x + 5$

- A) Standard form: $n(x) = -(x - 2)^2 + 9$
(A) x-intercepts: -1, 5; y-intercept: 5
(B) Vertex (-2, -9)
(C) Maximum: 9
(D) $y \leq 9$
- B) Standard form: $n(x) = -(x - 2)^2 + 9$
(A) x-intercepts: -1, 5; y-intercept: 5
(B) Vertex (2, 9)
(C) Maximum: 9
(D) $y \leq 9$
- C) Standard form: $n(x) = -(x + 2)^2 + 9$
(A) x-intercepts: -1, 5; y-intercept: 5
(B) Vertex (2, 9)
(C) Minimum: 9
(D) $y \geq 9$
- D) Standard form: $n(x) = -(x + 2)^2 + 9$
(A) x-intercepts: -5, 1; y-intercept: 5
(B) Vertex (2, 9)
(C) Maximum: 9
(D) $y \leq 9$

Answer: B

Determine whether there is a maximum or minimum value for the given function, and find that value.

70) $f(x) = x^2 - 20x + 104$

- A) Minimum: 0
B) Maximum: -4
C) Minimum: 4
D) Maximum: 10

Answer: C

71) $f(x) = -x^2 - 18x - 90$

- A) Minimum: -9
B) Minimum: 0
C) Minimum: 9
D) Maximum: -9

Answer: D

Find the range of the given function. Express your answer in interval notation.

72) $f(x) = 4x^2 + 16x + 19$

- A) $[-2, \infty)$
B) $[3, \infty)$
C) $(-\infty, 2]$
D) $(-\infty, -3]$

Answer: B

73) $f(x) = -2x^2 + 12x - 23$

- A) $(-\infty, -3]$
- B) $[-3, \infty)$
- C) $[5, \infty)$
- D) $(-\infty, -5]$

Answer: D

SHORT ANSWER. Write the word or phrase that best completes each statement or answers the question.

Provide an appropriate response.

74) Find the vertex and the maximum or minimum of the quadratic function $f(x) = -x^2 - 4x + 5$ by first writing f in standard form. State the range of f and find the intercepts of f .

Answer: $f(x) = -(x + 2)^2 + 9$; vertex: $(-2, 9)$; maximum: $f(-2) = 9$; Range of $f = \{y \mid y \leq 9\}$; y-intercept: $(0, 5)$; x-intercepts: $(-5, 0), (1, 0)$.

75) Graph $f(x) = -x^2 - x + 6$ and indicate the maximum or minimum value of $f(x)$, whichever exists.

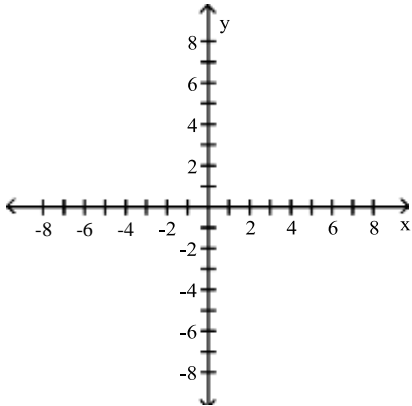

Answer: Max $f(x) = \frac{25}{4}$

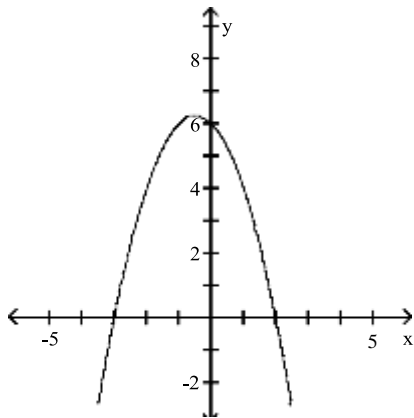

MULTIPLE CHOICE. Choose the one alternative that best completes the statement or answers the question.

Write an equation for the graph in the form $y = a(x - h)^2 + k$, where a is either 1 or -1 and h and k are integers.

76)

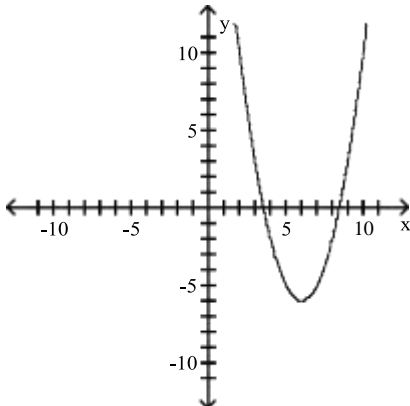

- A) $y = (x - 6)^2 - 5$
- B) $y = (x + 6)^2 + 5$
- C) $y = (x - 5)^2 - 6$
- D) $y = (x - 6)^2 - 6$

Answer: D

77)

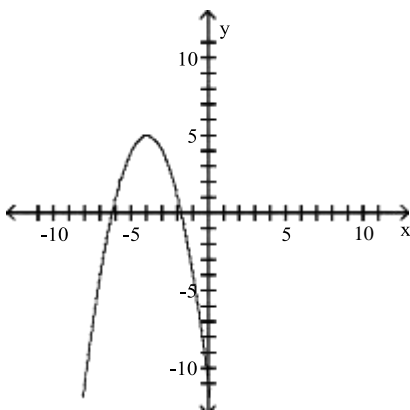

- A) $y = -(x + 4)^2 + 5$
- B) $y = (x + 4)^2 - 2$
- C) $y = (x + 4)^2 + 5$
- D) $y = -(x - 4)^2 - 5$

Answer: A

Solve graphically to two decimal places using a graphing calculator.

78) $1.9x^2 - 3.1x - 2.7 > 0$

- A) $-2.26 < x < 0.63$
- B) $x < -2.26$ or $x > 0.63$
- C) $-0.63 < x < 2.26$
- D) $x < -0.63$ or $x > 2.26$

Answer: D

- 79) $1.3x^2 - 2.1x - 3.2 \leq 0$
 A) $-0.96 < x < 2.57$
 B) $-2.57 < x < 0.96$
 C) $x < -0.96$ or $x > 2.57$
 D) $x < -2.57$ or $x > 0.96$

Answer: A

Solve the equation graphically to four decimal places.

- 80) Let $f(x) = -0.5x^2 + 4x + 2$, find $f(x) = 3$.
 A) 0.2583, 7.7417
 B) 0.2583
 C) No solution
 D) 7.7417

Answer: A

- 81) Let $f(x) = -0.5x^2 + 4x + 2$, find $f(x) = -5$.
 A) -1.4772, 9.4772
 B) No solution
 C) 9.4772
 D) -1.4772

Answer: A

- 82) Let $f(x) = -0.4x^2 + 2x + 3$, find $f(x) = 6$.
 A) 2.5000, 5.5000
 B) 2.5000
 C) No solution
 D) 5.5000

Answer: C

For the following problem, (i) graph f and g in the same coordinate system; (ii) solve $f(x) = g(x)$ algebraically to two decimal places; (iii) solve $f(x) > g(x)$ using parts i and ii; (iv) solve $f(x) < g(x)$ using parts i and ii.

- 83) $f(x) = -0.8x(x - 8)$, $g(x) = 0.4x + 3.2$; $0 \leq x \leq 10$

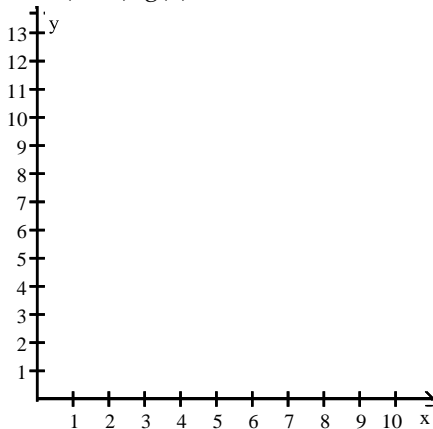

A) (i) f is the curve, g is the line

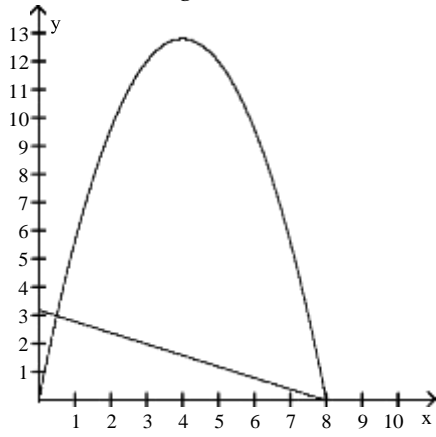

(ii) 0.61, 7.98

(iii) $0.61 < x < 7.98$

(iv) $0 \leq x < 0.61$ or $7.98 < x \leq 8$

B) (i) f is the curve, g is the line

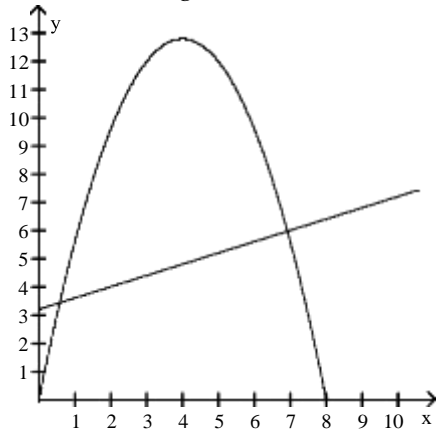

(ii) 0.61, 7.02

(iii) $0.61 < x < 7.02$

(iv) $0 \leq x < 0.61$ or $7.02 < x \leq 8$

C) (i) f is the curve, g is the line

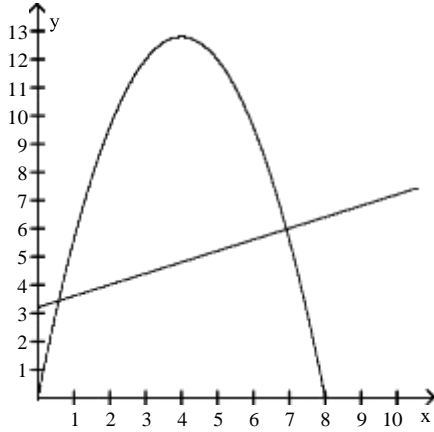

(ii) 0.58, 6.92

(iii) $0.58 < x < 6.92$

(iv) $0 \leq x < 0.58$ or $6.92 < x \leq 8$

D) (i) f is the curve, g is the line

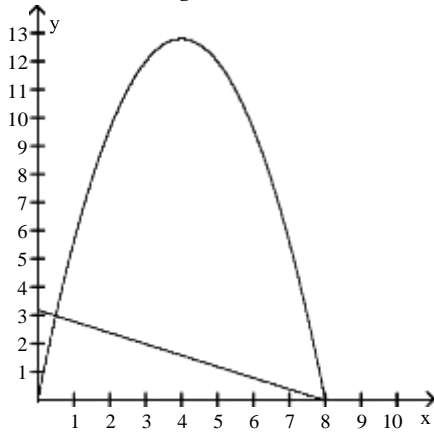

(ii) 0.58, 7.98

(iii) $0.58 < x < 7.98$

(iv) $0 \leq x < 0.58$ or $7.98 < x \leq 8$

Answer: C

Solve the problem.

84) In economics, functions that involve revenue, cost and profit are used. Suppose $R(x)$ and $C(x)$ denote the total revenue and the total cost, respectively, of producing a new high-tech widget. The difference $P(x) = R(x) - C(x)$ represents the total profit for producing x widgets. Given $R(x) = 60x - 0.4x^2$ and $C(x) = 3x + 13$, find the equation for $P(x)$.

A) $P(x) = -0.4x^2 + 63x + 13$

B) $P(x) = 60x - 0.4x^2$

C) $P(x) = -0.4x^2 + 57x - 13$

D) $P(x) = 3x + 13$

Answer: C

- 85) In economics, functions that involve revenue, cost and profit are used. Suppose $R(x)$ and $C(x)$ denote the total revenue and the total cost, respectively, of producing a new high-tech widget. The difference $P(x) = R(x) - C(x)$ represents the total profit for producing x widgets. Given $R(x) = 60x - 0.4x^2$ and $C(x) = 3x + 13$, find $P(100)$.
- A) 55687
 - B) 313
 - C) 1687
 - D) 2000

Answer: C

- 86) A professional basketball player has a vertical leap of 37 inches. A formula relating an athlete's vertical leap V , in inches, to hang time T , in seconds, is $V = 48T^2$. What is his hang time? Round to the nearest tenth.
- A) 1 sec
 - B) 0.8 sec
 - C) 0.9 sec
 - D) 0.6 sec

Answer: C

- 87) Under certain conditions, the power P , in watts per hour, generated by a windmill with winds blowing v miles per hour is given by $P(v) = 0.015v^3$. Find the power generated by 18-mph winds.
- A) 4.86 watts per hour
 - B) 58.32 watts per hour
 - C) 0.00006075 watts per hour
 - D) 87.48 watts per hour

Answer: D

- 88) The U. S. Census Bureau compiles data on population. The population (in thousands) of a southern city can be approximated by $P(x) = 0.08x^2 - 13.08x + 927$, where x corresponds to the years after 1950. In what calendar year was the population about 804,200?
- A) 1955
 - B) 1960
 - C) 1965
 - D) 2000

Answer: B

- 89) Assume that a person's critical weight W , defined as the weight above which the risk of death rises dramatically, is given by $W(h) = \left(\frac{h}{11.9}\right)^3$, where W is in pounds and h is the person's height in inches.

Find the critical weight for a person who is 6 ft 11 in. tall. Round to the nearest tenth.

- A) 221.5 lb
- B) 339.3 lb
- C) 377.4 lb
- D) 212.4 lb

Answer: B

- 90) The polynomial $0.0053x^3 + 0.003x^2 + 0.108x + 1.54$ gives the approximate total earnings of a company, in millions of dollars, where x represents the number of years since 1996. This model is valid for the years from 1996 to 2000. Determine the earnings for 2000. Round to 2 decimal places.
- A) \$2.36 million
 - B) \$2.03 million
 - C) \$2.82 million
 - D) \$2.26 million

Answer: A

Use the REGRESSION feature on a graphing calculator.

- 91) The average retail price in the Spring of 2000 for a used Camaro Z28 coupe depends on the age of the car as shown in the following table.

Age, x	1	2	3	4	5	6	7	8	9
Price, y	18,325	15,925	13,685	11,805	10,490	8885	8015	6480	5710

Find the quadratic model that best estimates this data. Round your answer to whole numbers.

- A) $y = 102x^2 - 2576x + 20,669$
- B) $y = 102x^2 - 2576x$
- C) $y = -1551x + 18,790x$
- D) $y = -9x^3 + 235x^2 - 3134x + 21,252$

Answer: A

- 92) As the number of farms has decreased in South Carolina, the average size of the remaining farms has grown larger, as shown below.

YEAR	AVERAGE ACREAGE PER FARM
1900 ($x = 0$)	127
1910 ($x = 10$)	119
1920	135
1930	137
1940	155
1950	196
1960	283
1970	353
1980	406
1990	440
2000 ($x = 100$)	420

Let x represent the number of years since 1900. Use a graphing calculator to fit a quadratic function to the data. Round your answer to five decimal places.

- A) $y = 0.02536x^3 + 1.21114 + 102.58741$
- B) $y = 0.02536x^3 + 1.21114x + 102.58741$
- C) $y = 0.02536x^2 + 1.21114x + 102.58741$
- D) $y = -.00114x^3 + 0.19605x^2 - 5.29775 + 143.55245$

Answer: C

93) Since 1984 funeral directors have been regulated by the Federal Trade Commission. The average cost of a funeral for an adult in a Midwest city has increased, as shown in the following table.

YEAR	AVERAGE COST OF FUNERAL
1980	\$ 1926
1985	\$ 2841
1991	\$ 3842
1995	\$ 4713
1996	\$ 4830
1998	\$ 5120
2001	\$ 5340

Let x represent the number of years since 1980. Use a graphing calculator to fit a quartic function to the data. Round your answer to five decimal places.

- A) $y = -0.04268x^4$
- B) $y = -0.04268x^4 + 1.53645x^3 - 16.76289x^2 + 231.82723x + 1927.58518$
- C) $y = -2.047489x^2 + 212.82699x + 1879.85469$
- D) $y = 170.5971x + 1991.5213$

Answer: B

Solve the problem.

94) The population P , in thousands, of Fayetteville is given by $P(t) = \frac{300t}{2t^2 + 7}$, where t is the time, in months. Find

the population at 9 months.

- A) 40,000
- B) 7988
- C) 30,769
- D) 15,976

Answer: D

95) If the average cost per unit $C(x)$ to produce x units of plywood is given by $C(x) = \frac{1200}{x + 40}$, what is the unit cost for

10 units?

- A) \$3.00
- B) \$120.00
- C) \$80.00
- D) \$24.00

Answer: D

96) Suppose the cost per ton, y , to build an oil platform of x thousand tons is approximated by $C(x) = \frac{212,500}{x + 425}$.

What is the cost per ton for $x = 30$?

- A) \$425.00
- B) \$16.67
- C) \$7083.33
- D) \$467.03

Answer: D

SHORT ANSWER. Write the word or phrase that best completes each statement or answers the question.

- 97) The financial department of a company that produces digital cameras arrived at the following price-demand function and the corresponding revenue function:

$$p(x) = 95.4 - 6x \quad \text{price-demand}$$

$$R(x) = x \cdot p(x) = x(95.4 - 6x) \quad \text{revenue function}$$

The function $p(x)$ is the wholesale price per camera at which x million cameras can be sold and $R(x)$ is the corresponding revenue (in million dollars). Both functions have domain $1 \leq x \leq 15$. They also found the cost function to be $C(x) = 150 + 15.1x$ (in million dollars) for manufacturing and selling x cameras. Find the profit function and determine the approximate number of cameras, rounded to the nearest hundredths, that should be sold for maximum profit.

Answer: $P(x) = -6x^2 + 80.3x - 150$, must sell approximately 6.69 million cameras.

- 98) The financial department of a company that manufactures portable MP3 players arrived at the following daily cost equation for manufacturing x MP3 players per day: $C(x) = 1500 + 105x + x^2$. The average cost per unit at a production level of players per day is $\bar{C}(x) = \frac{C(x)}{x}$.

- (A) Find the rational function \bar{C} .
 (B) Graph the average cost function on a graphing utility for $10 \leq x \leq 200$.
 (C) Use the appropriate command on a graphing utility to find the daily production level (to the nearest integer) at which the average cost per player is a minimum. What is the minimum average cost (to the nearest cent)?

Answer: (A) $\bar{C}(x) = \frac{1500}{x} + 105 + x$

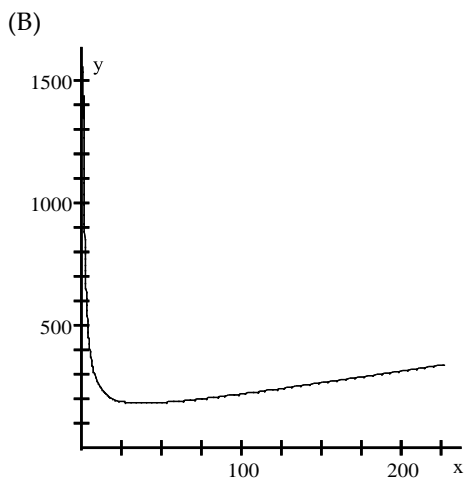

(C) 39; \$182.46

MULTIPLE CHOICE. Choose the one alternative that best completes the statement or answers the question.

For the polynomial function find the following: (i) Degree of the polynomial; (ii) All x intercepts; (iii) The y intercept.

99) $y = 4x + 5$

- A) (i) 1
(ii) 5
(iii) $\frac{5}{4}$

- B) (i) 1
(ii) $\frac{5}{4}$

- (iii) 5
C) (i) 1
(ii) $-\frac{5}{4}$

- (iii) 5
D) (i) 1
(ii) $-\frac{4}{5}$
(iii) 4

Answer: C

100) $y = x^2 - 196$

- A) (i) 1
(ii) 98
(iii) -196
B) (i) 2
(ii) -15, 15
(iii) -196
C) (i) 2
(ii) -14, 14
(iii) -196
D) (i) 1
(ii) 14
(iii) -196

Answer: C

101) $y = x^2 + 5x - 66$

- A) (i) 2
(ii) -11, 6
(iii) -66
- B) (i) 2
(ii) 11, -6
(iii) -66
- C) (i) 2
(ii) -11, 1
(iii) -66
- D) (i) 2
(ii) 11, 6
(iii) -66

Answer: A

102) $y = 15 - x^2 + 2x$

- A) (i) 2
(ii) -3, -5
(iii) -15
- B) (i) 2
(ii) 3, -5
(iii) -15
- C) (i) 2
(ii) 5, -3
(iii) 15
- D) (i) 2
(ii) 5, 3
(iii) 15

Answer: C

103) $y = (x + 6)(x + 8)(x + 5)$

- A) (i) 3
(ii) 6, 8, 5
(iii) 240
- B) (i) 3
(ii) -6, -8, -5
(iii) -40
- C) (i) 3
(ii) -6, -8, -5
(iii) 240
- D) (i) 3
(ii) 6, 8, 5
(iii) 40

Answer: C

104) $f(x) = (x^6 + 7)(x^{10} + 9)$

- A) (i) 16
(ii) 7, 9
(iii) 63
- B) (i) 16
(ii) none
(iii) 63
- C) (i) 60
(ii) none
(iii) -63
- D) (i) 60
(ii) 7, 9
(iii) -63

Answer: B

The graph that follows is the graph of a polynomial function. (i) What is the minimum degree of a polynomial function that could have the graph? (ii) Is the leading coefficient of the polynomial negative or positive?

105)

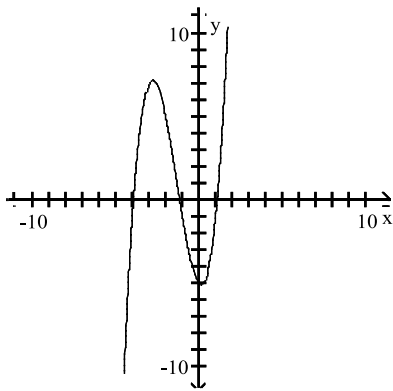

- A) (i) 3
(ii) Negative
- B) (i) 2
(ii) Negative
- C) (i) 3
(ii) Positive
- D) (i) 2
(ii) Positive

Answer: C

106)

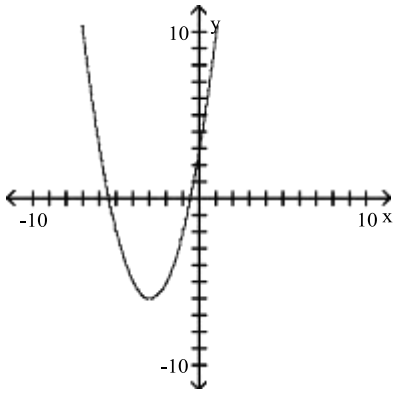

- A) (i) 2
(ii) Negative
- B) (i) 3
(ii) Negative
- C) (i) 3
(ii) Positive
- D) (i) 2
(ii) Positive

Answer: D

107)

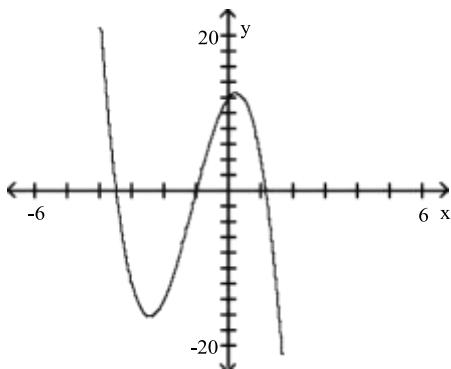

- A) (i) 3
(ii) Positive
- B) (i) 4
(ii) Positive
- C) (i) 4
(ii) Negative
- D) (i) 3
(ii) Negative

Answer: D

108)

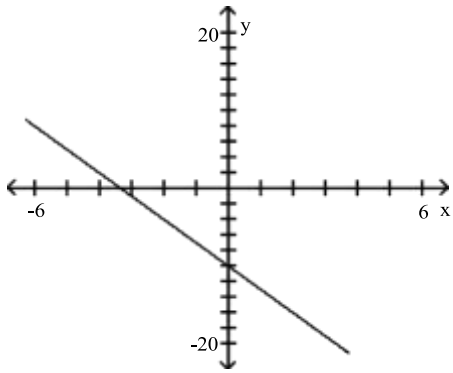

- A) (i) 1
(ii) Positive
- B) (i) 1
(ii) Negative
- C) (i) 2
(ii) Negative
- D) (i) 2
(ii) Positive

Answer: B

109)

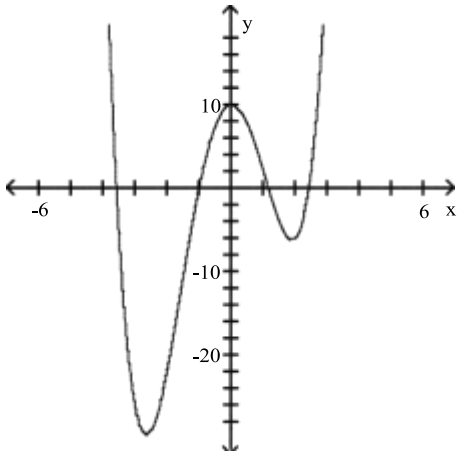

- A) (i) 3
(ii) Negative
- B) (i) 3
(ii) Positive
- C) (i) 4
(ii) Positive
- D) (i) 4
(ii) Negative

Answer: C

Provide an appropriate response.

110) What is the maximum number of x intercepts that a polynomial of degree 6 can have?

- A) 6
- B) 7
- C) 5
- D) Not enough information is given.

Answer: A

111) What is the minimum number of x intercepts that a polynomial of degree 11 can have? Explain.

- A) 1 because a polynomial of odd degree crosses the x axis at least once.
- B) 11 because this is the degree of the polynomial.
- C) 0 because a polynomial of odd degree may not cross the x axis at all.
- D) Not enough information is given.

Answer: A

112) What is the minimum number of x intercepts that a polynomial of degree 8 can have? Explain.

- A) 8 because this is the degree of the polynomial.
- B) 1 because a polynomial of even degree crosses the x axis at least once.
- C) 0 because a polynomial of even degree may not cross the x axis at all.
- D) Not enough information is given.

Answer: C

For the rational function below (i) Find the intercepts for the graph; (ii) Determine the domain; (iii) Find any vertical or horizontal asymptotes for the graph; (iv) Sketch any asymptotes as dashed lines. Then sketch the graph of $y = f(x)$.

113) $f(x) = \frac{x+2}{x+1}$

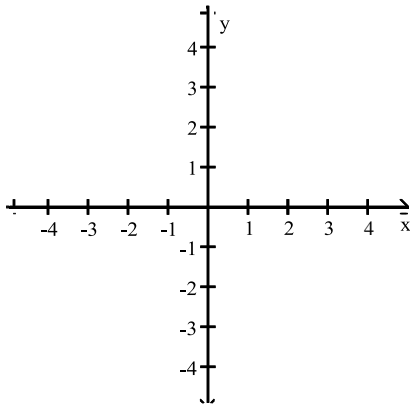

- A) (i) x intercept: 0; y intercept: 0
(ii) Domain: all real numbers except 1
(iii) Vertical asymptote: $x = 1$; horizontal asymptote: $y = 1$
(iv)

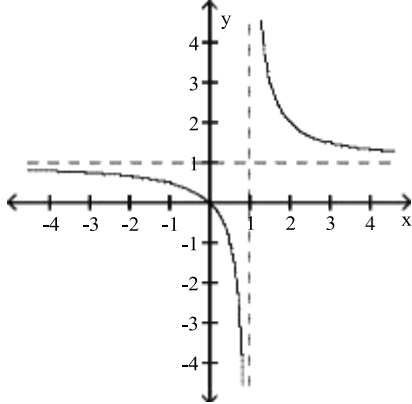

- B) (i) x intercept: 2; y intercept: 2
(ii) Domain: all real numbers except 1
(iii) Vertical asymptote: $x = 1$; horizontal asymptote: $y = 1$
(iv)

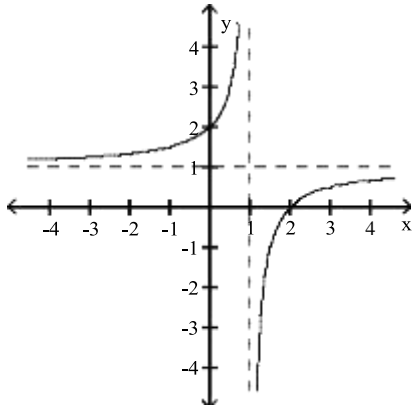

- C) (i) x intercept: -2; y intercept: 2
(ii) Domain: all real numbers except -1
(iii) Vertical asymptote: $x = -1$; horizontal asymptote: $y = 1$
(iv)

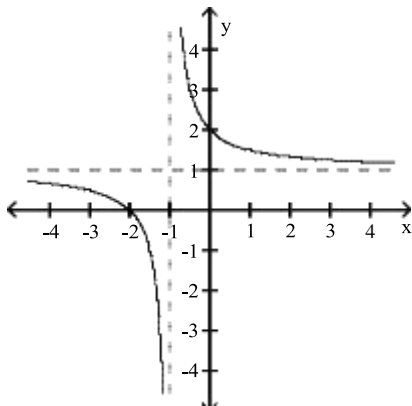

- D) (i) x intercept: 0; y intercept: 0
(ii) Domain: all real numbers except -1
(iii) Vertical asymptote: $x = -1$; horizontal asymptote: $y = 1$
(iv)

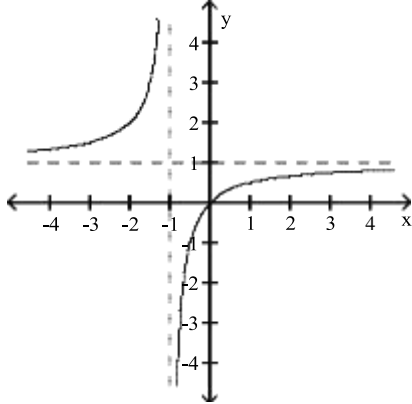

Answer: C

114) $f(x) = \frac{x-3}{x-4}$

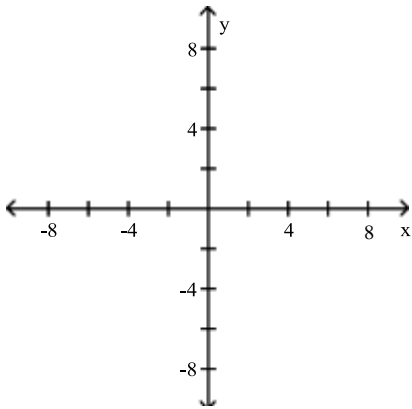

- A) (i) x intercept: -3; y intercept: $\frac{3}{4}$

- (ii) Domain: all real numbers except -4
(iii) Vertical asymptote: $x = -4$; horizontal asymptote: $y = 1$
(iv)

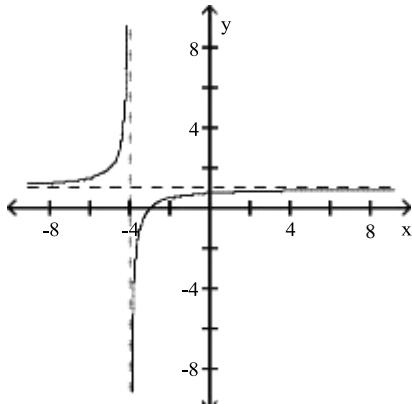

B) (i) x intercept: 3; y intercept: $\frac{3}{4}$

(ii) Domain: all real numbers except 4

(iii) Vertical asymptote: $x = 4$; horizontal asymptote: $y = 1$

(iv)

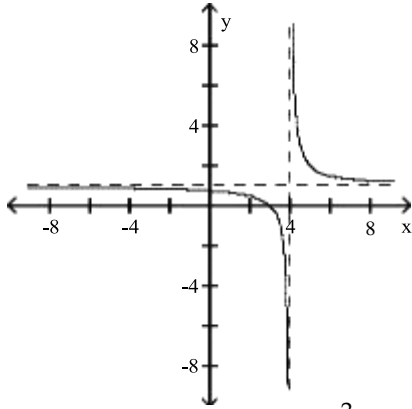

C) (i) x intercept: 5; y intercept: $\frac{3}{4}$

(ii) Domain: all real numbers except 4

(iii) Vertical asymptote: $x = 4$; horizontal asymptote: $y = 1$

(iv)

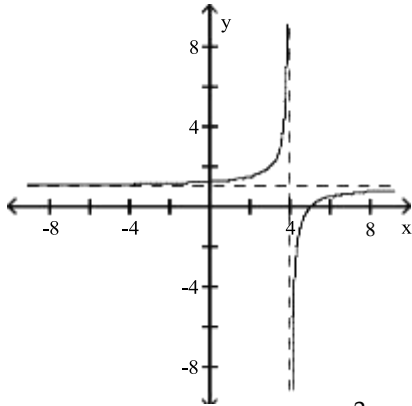

D) (i) x intercept: -5; y intercept: $\frac{3}{4}$

(ii) Domain: all real numbers except -4

(iii) Vertical asymptote: $x = -4$; horizontal asymptote: $y = 1$

(iv)

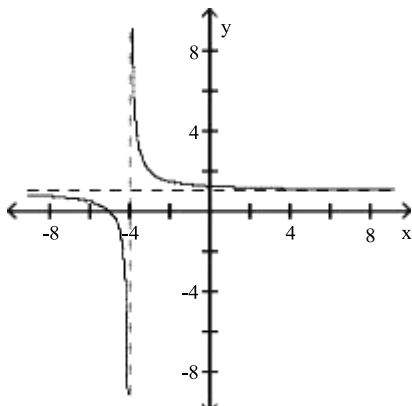

Answer: B

115) $f(x) = \frac{3x}{x-2}$

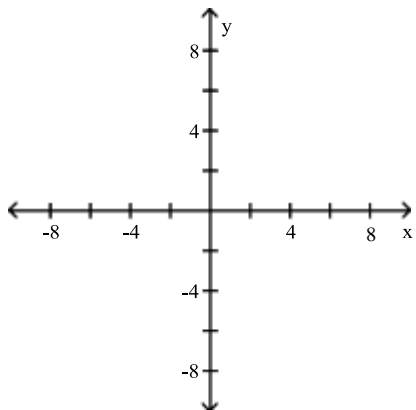

- A) (i) x intercept: 0; y intercept: 0
(ii) Domain: all real numbers except 2
(iii) Vertical asymptote: $x = 2$; horizontal asymptote: $y = 3$
(iv)

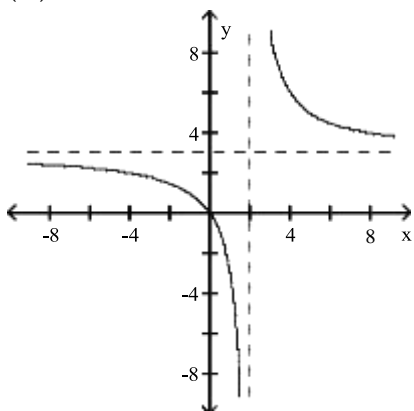

- B) (i) x intercept: 0; y intercept: 0
(ii) Domain: all real numbers except -2
(iii) Vertical asymptote: $x = -2$; horizontal asymptote: $y = 3$
(iv)

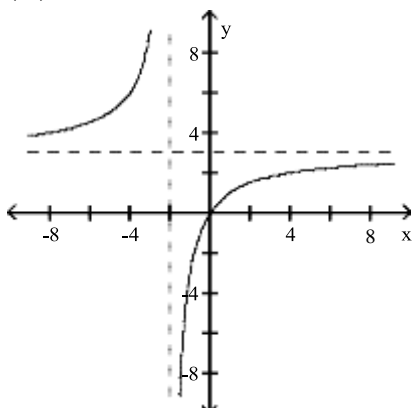

- C) (i) x intercept: 0; y intercept: 0
(ii) Domain: all real numbers except -2
(iii) Vertical asymptote: $x = -2$; horizontal asymptote: $y = -3$
(iv)

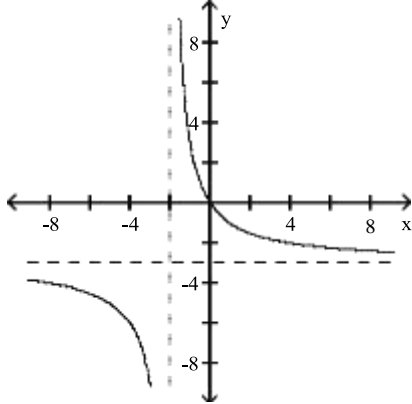

- D) (i) x intercept: 0; y intercept: 0
(ii) Domain: all real numbers except 2
(iii) Vertical asymptote: $x = 2$; horizontal asymptote: $y = -3$
(iv)

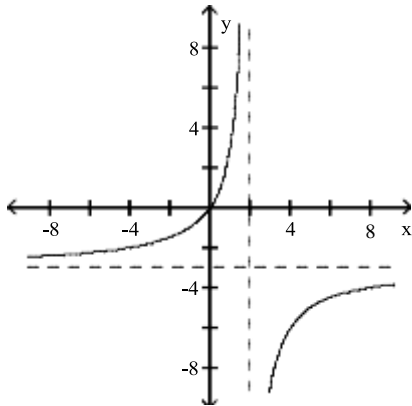

Answer: A

116) $f(x) = \frac{-2x - 3}{x + 2}$

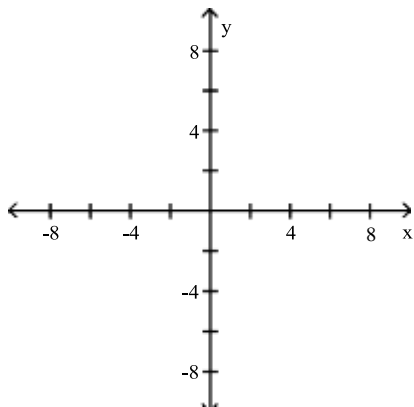

A) (i) x intercept: $-\frac{3}{2}$; y intercept: $-\frac{3}{2}$

(ii) Domain: all real numbers except -2

(iii) Vertical asymptote: $x = -2$; horizontal asymptote: $y = -2$

(iv)

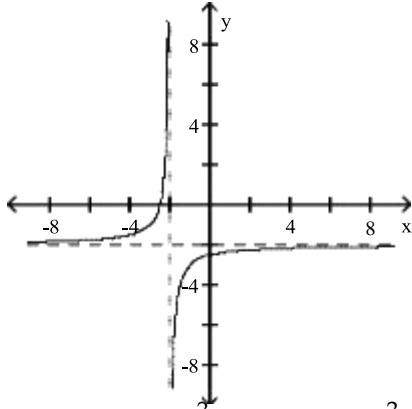

B) (i) x intercept: $-\frac{3}{2}$; y intercept: $-\frac{3}{2}$

(ii) Domain: all real numbers except -2

(iii) Vertical asymptote: $x = -2$; horizontal asymptote: $y = -2$

(iv)

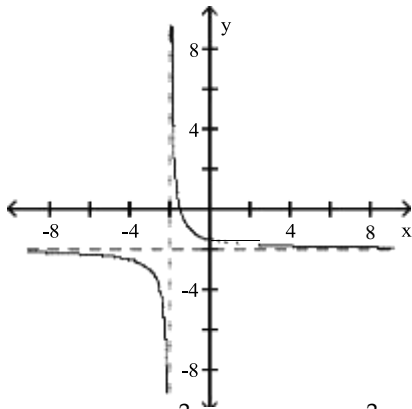

C) (i) x intercept: $\frac{3}{2}$; y intercept: $-\frac{3}{2}$

(ii) Domain: all real numbers except 2

(iii) Vertical asymptote: $x = 2$; horizontal asymptote: $y = -2$

(iv)

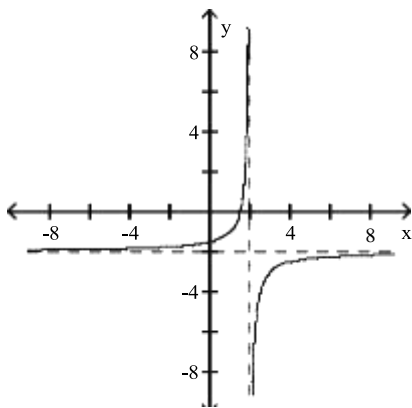

D) (i) x intercept: $\frac{3}{2}$; y intercept: $-\frac{3}{2}$

(ii) Domain: all real numbers except 2

(iii) Vertical asymptote: $x = 2$; horizontal asymptote: $y = -2$

(iv)

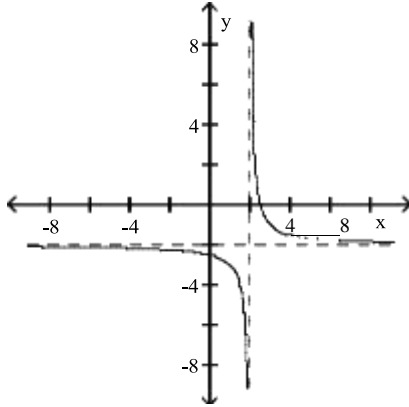

Answer: B

For the rational function below (i) Find any intercepts for the graph; (ii) Find any vertical and horizontal asymptotes for the graph; (iii) Sketch any asymptotes as dashed lines. Then sketch a graph of f.

$$117) y = \frac{6}{x^2 - 1}$$

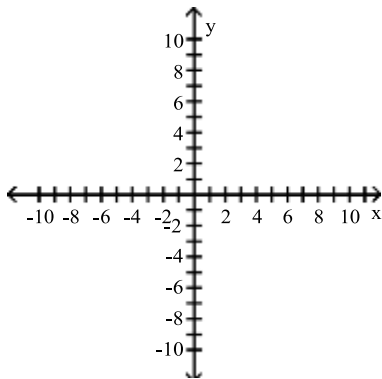

A) (i) y intercept: -2

(ii) horizontal asymptote: $y = 0$; vertical asymptotes: $x = 2$ and $x = -2$

(iii)

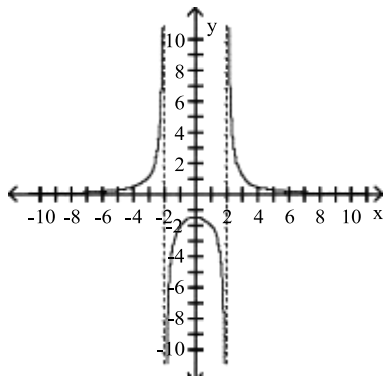

- B) (i) y intercept: - 6
(ii) horizontal asymptote: $y = 0$
(iii)

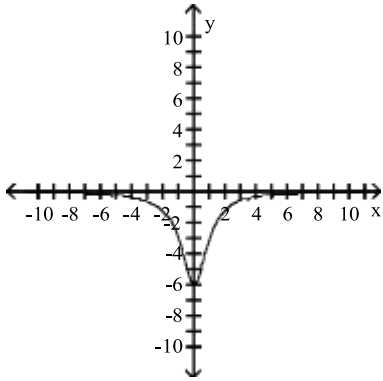

- C) (i) y intercept: - 6
(ii) horizontal asymptote: $y = 0$; vertical asymptotes: $x = 1$ and $x = -1$
(iii)

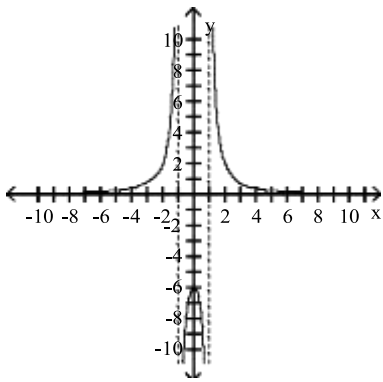

- D) (i) y intercept: 2
(ii) horizontal asymptote: $y = 0$; vertical asymptotes: $x = 2$ and $x = -2$
(iii)

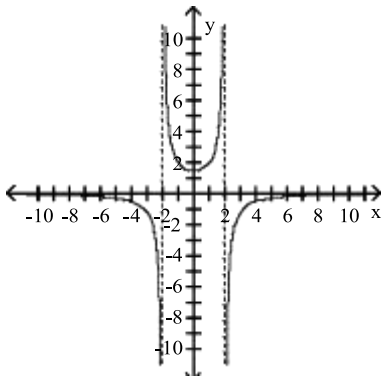

Answer: C

Sketch the graph of the function.

118) $f(x) = \frac{x+1}{x^2+x-2}$

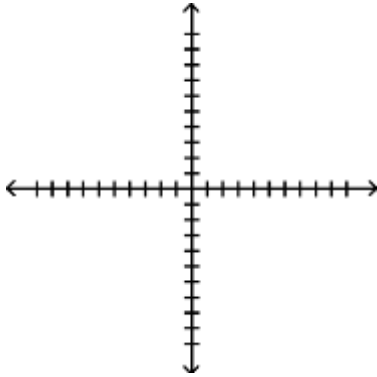

A)

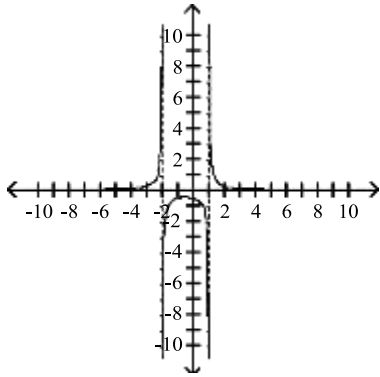

B)

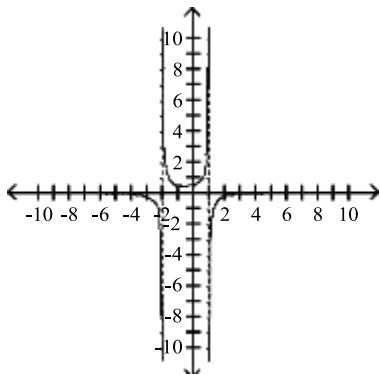

C)

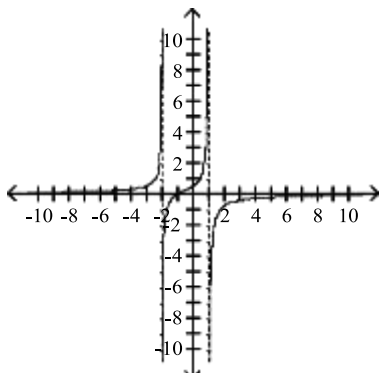

D)

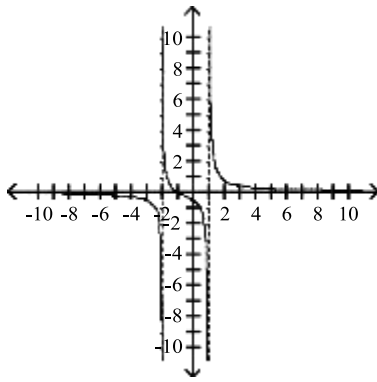

Answer: D

$$119) f(x) = \frac{x^2}{x^2 - x - 6}$$

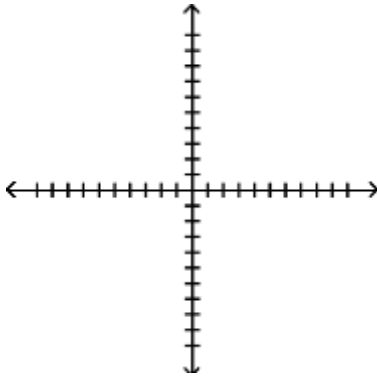

A)

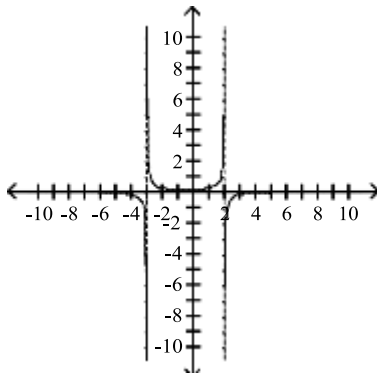

B)

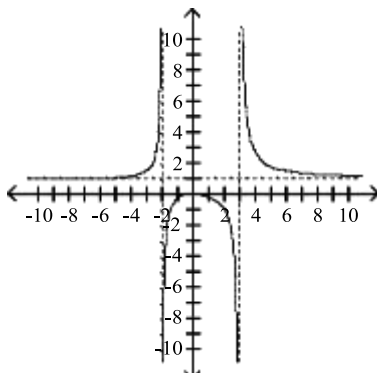

C)

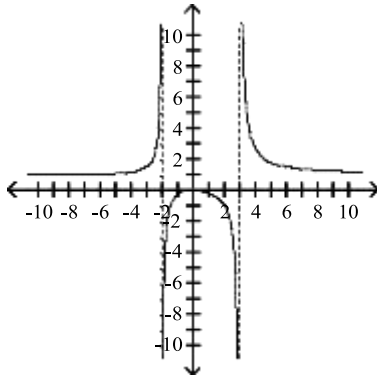

D)

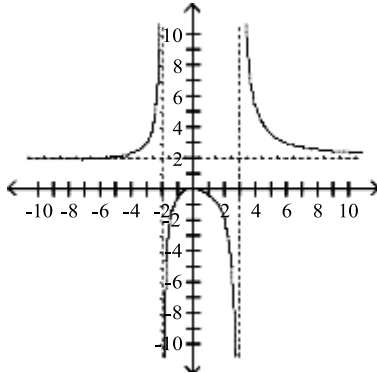

Answer: B

Find the equation of any horizontal asymptote.

$$120) f(x) = \frac{4x^2 - 3x - 8}{7x^2 - 8x + 2}$$

A) $y = \frac{0}{3}$

B) $y = \frac{4}{8}$

C) $y = \frac{4}{7}$

D) None

Answer: C

$$121) f(x) = \frac{7x^2 + 8}{7x^2 - 8}$$

A) $y = 8$

B) $y = -8$

C) $y = 1$

D) None

Answer: C

$$122) f(x) = \frac{x^2 + 9x - 7}{x - 7}$$

- A) $y = -9$
- B) None
- C) $y = 4$
- D) $y = 7$

Answer: B

Find the equations of any vertical asymptotes.

$$123) f(x) = \frac{4x - 11}{x^2 + 2x - 63}$$

- A) $x = -7, x = 9$
- B) $x = 7, x = -9$
- C) $y = 4$
- D) $y = 7, y = -9$

Answer: B

$$124) f(x) = \frac{x^2 - 100}{(x - 8)(x + 9)}$$

- A) $x = 8, x = -9$
- B) $y = 8, y = -9$
- C) $x = 10, x = -10$
- D) $x = -8$

Answer: A

$$125) f(x) = \frac{x^2 + 4x}{x^2 - 4x - 32}$$

- A) $x = 8, x = -4$
- B) $x = 8$
- C) $x = -8, x = 4$
- D) None

Answer: B

$$126) f(x) = \frac{x - 4}{x^2 + 8}$$

- A) $x = -8$
- B) $x = 8$
- C) $x = 2, x = -2$
- D) None

Answer: D

Write an equation for the lowest-degree polynomial function with the graph and intercepts shown in the figure.

127)

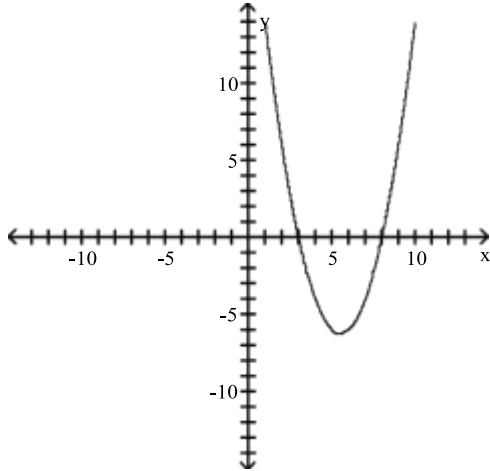

- A) $f(x) = x^2 + 24x + 11$
- B) $f(x) = x^2 + 24x - 11$
- C) $f(x) = x^2 - 11x + 24$
- D) $f(x) = x^2 + 11x + 24$

Answer: C

128)

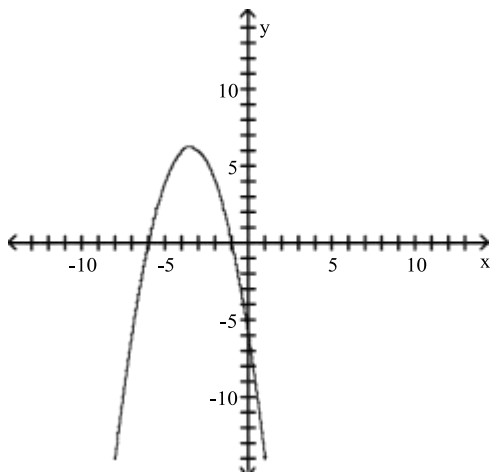

- A) $f(x) = x^2 + 6x + 7$
- B) $f(x) = x^2 + 6x - 7$
- C) $f(x) = -x^2 - 7x - 6$
- D) $f(x) = x^2 + 7x + 6$

Answer: C

129)

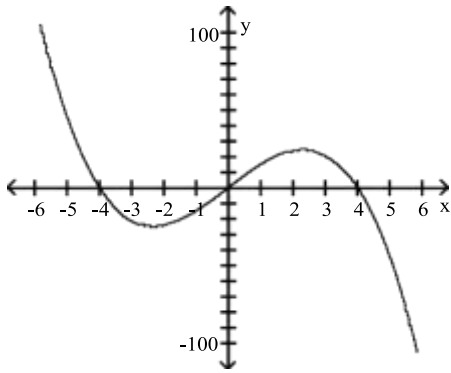

- A) $f(x) = -x^3 + 16x$
- B) $f(x) = -x^3 - 16x$
- C) $f(x) = x^3 + 16x$
- D) $f(x) = -x^3 - 16x$

Answer: A

Solve the problem.

130) Financial analysts in a company that manufactures ovens arrived at the following daily cost equation for manufacturing x ovens per day: $C(x) = x^2 + 4x + 1800$. The average cost per unit at a production level of x ovens per day is $\bar{C}(x) = C(x)/x$. (i) Find the rational function \bar{C} . (ii) Sketch a graph of $\bar{C}(x)$ for $10 \leq x \leq 125$. (iii) For what daily production level (to the nearest integer) is the average cost per unit at a minimum, and what is the minimum average cost per oven (to the nearest cent)? HINT: Refer to the sketch in part (ii) and evaluate $\bar{C}(x)$ at appropriate integer values until a minimum value is found.

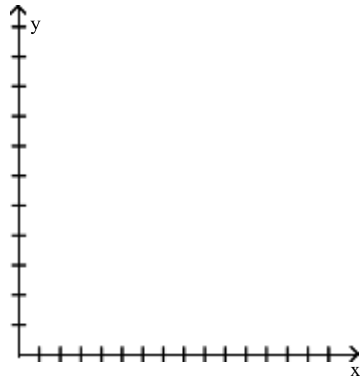

A) (i) $\bar{C}(x) = \frac{x^2 + 4x + 1800}{x}$

(ii)

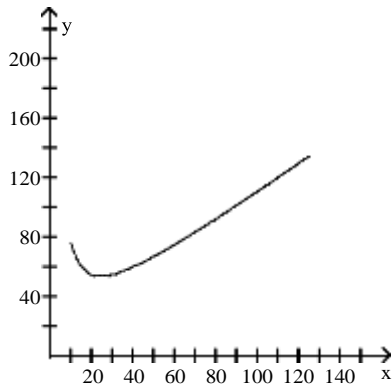

(iii) 22 units; \$48.93 per oven

B) (i) $\epsilon(x) = \frac{x^2 + 4x + 1800}{x}$

(ii)

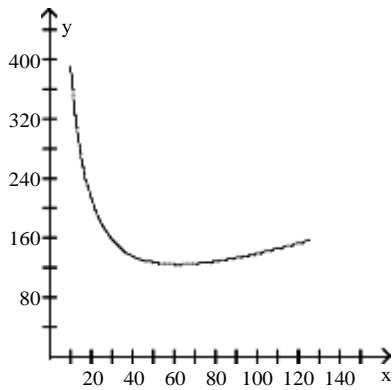

(iii) 61 units; \$133.29 per oven

C) (i) $\epsilon(x) = \frac{x^2 + 4x + 1800}{x}$

(ii)

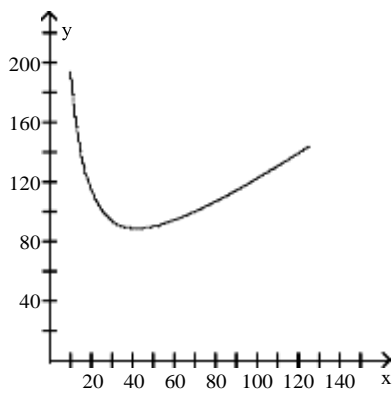

(iii) 42 units; \$88.86 per oven

D) (i) $\bar{C}(x) = \frac{x^2 + 4x + 1800}{x}$

(ii)

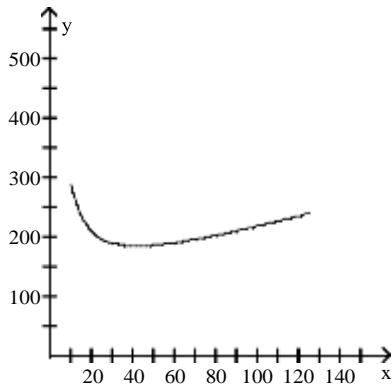

(iii) 44 units; \$185.61 per oven

Answer: C

Graph the function.

131) $f(x) = \left(\frac{1}{4}\right)^x$

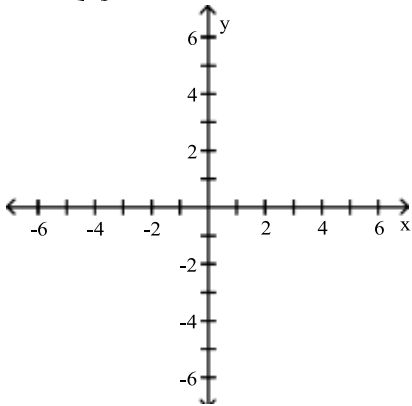

A)

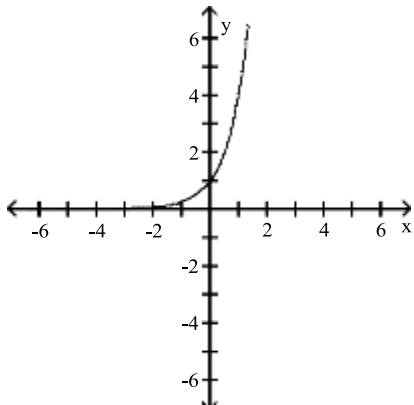

B)

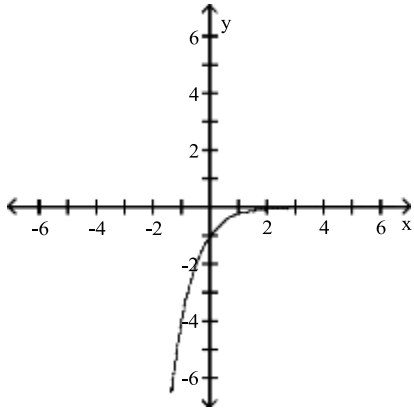

C)

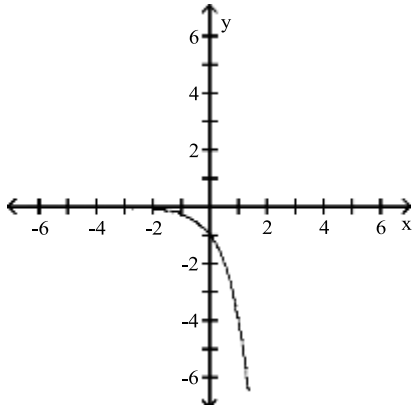

D)

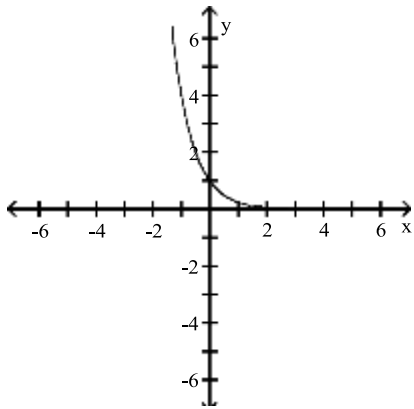

Answer: D

132) $f(x) = 5^{(x - 2)} - 2$

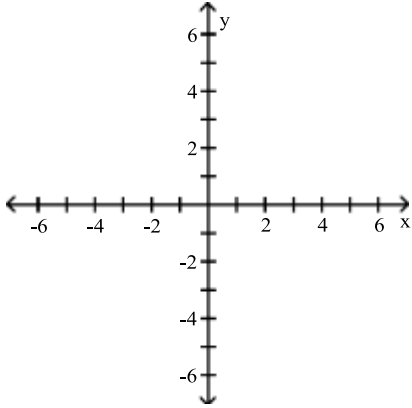

A)

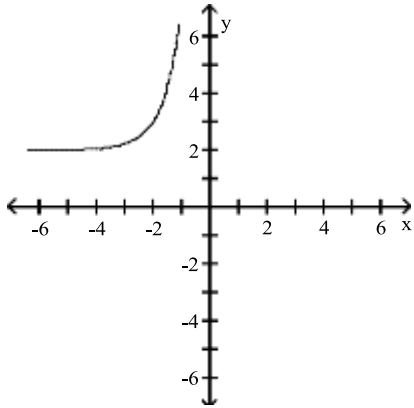

B)

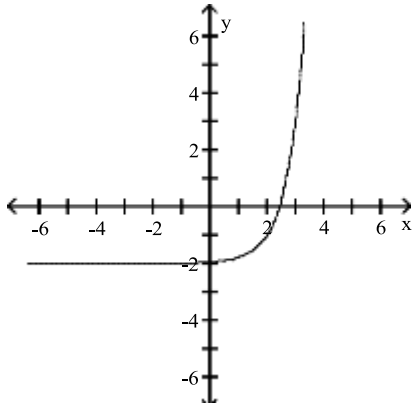

C)

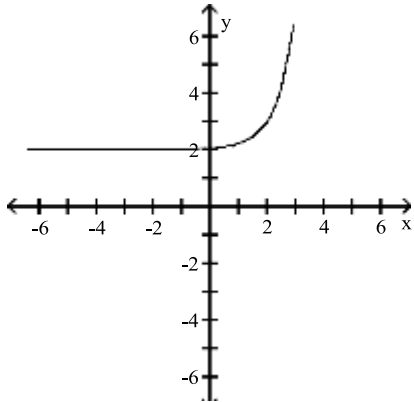

D)

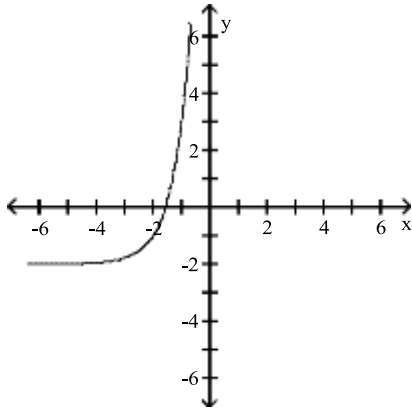

Answer: B

133) $f(x) = 2^{-x} - 2$

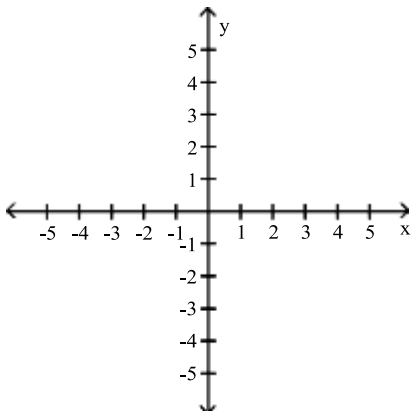

A)

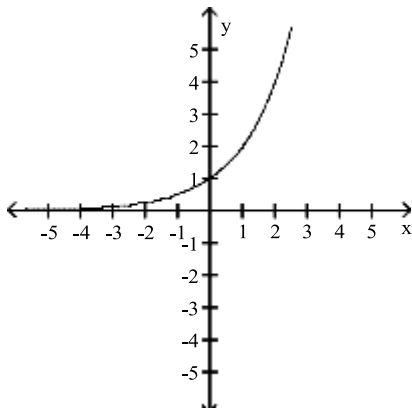

B)

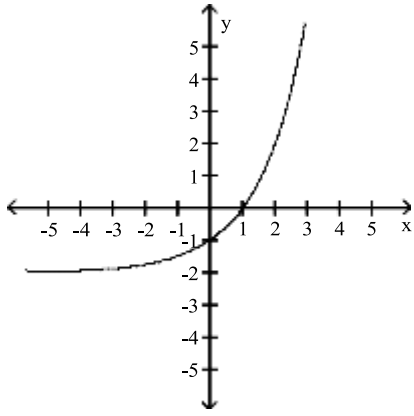

C)

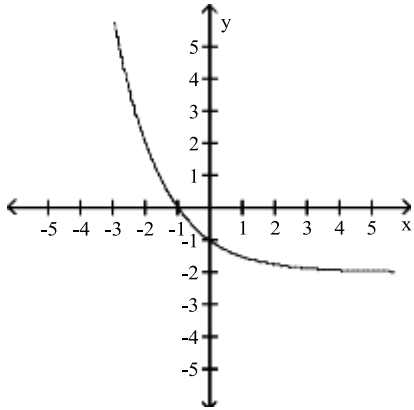

D)

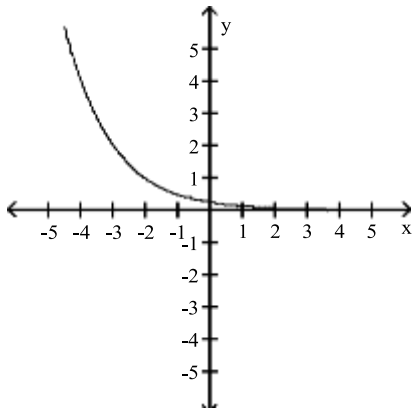

Answer: C

134) $f(x) = 0.6^x$

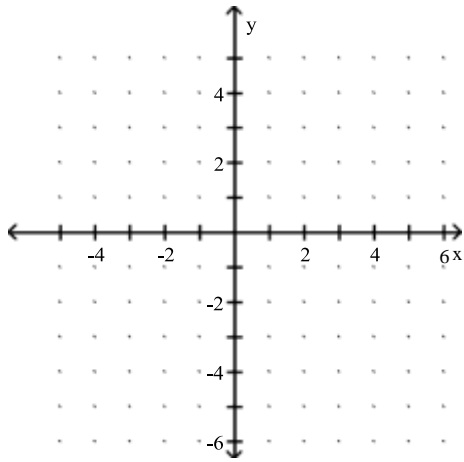

A)

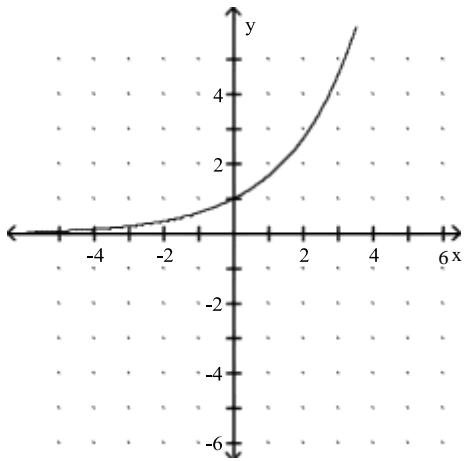

B)

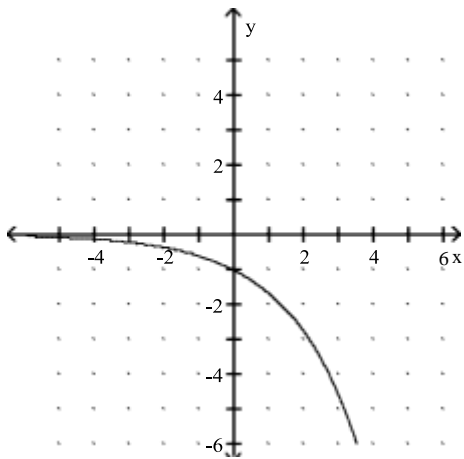

C)

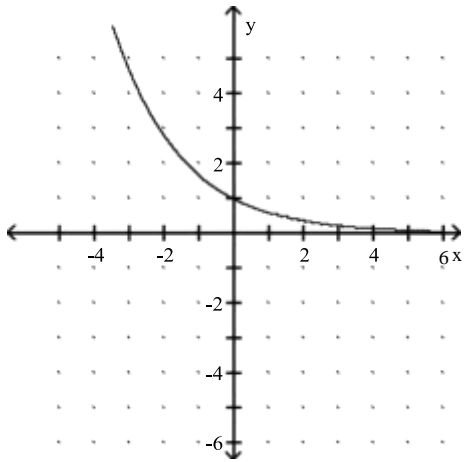

D)

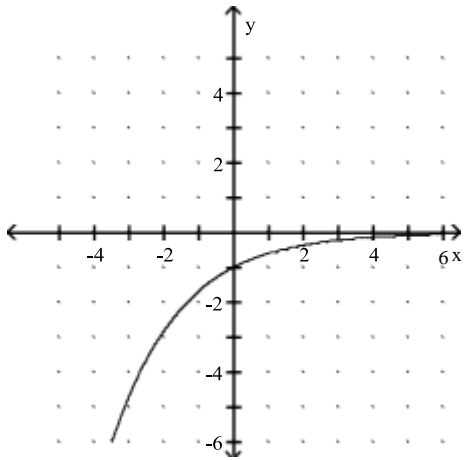

Answer: C

135) $f(x) = 5^x$

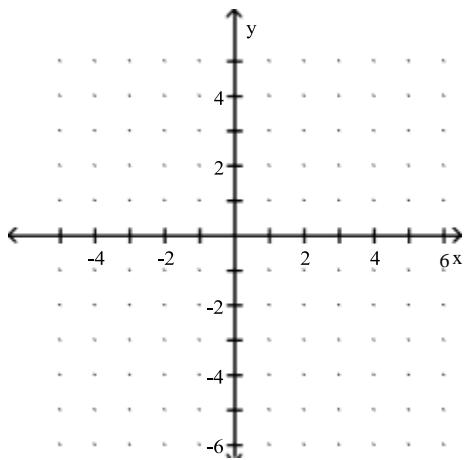

A)

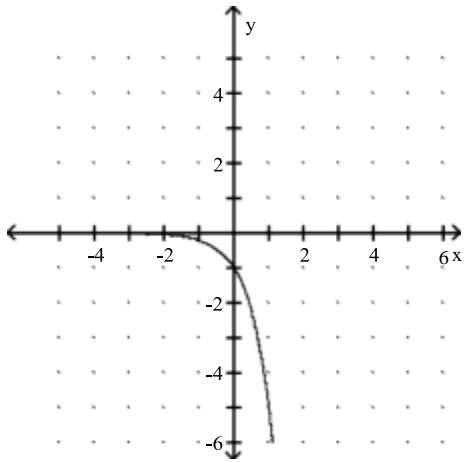

B)

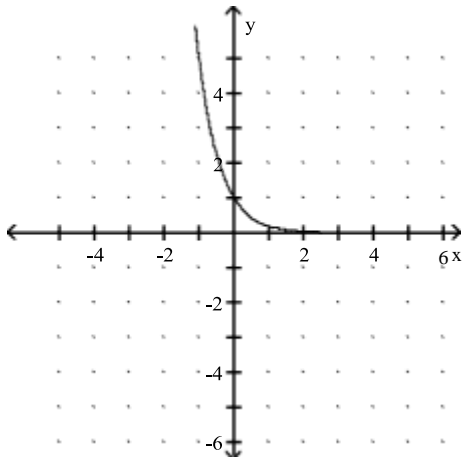

C)

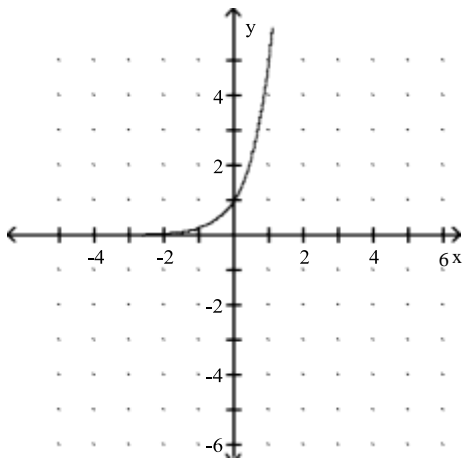

D)

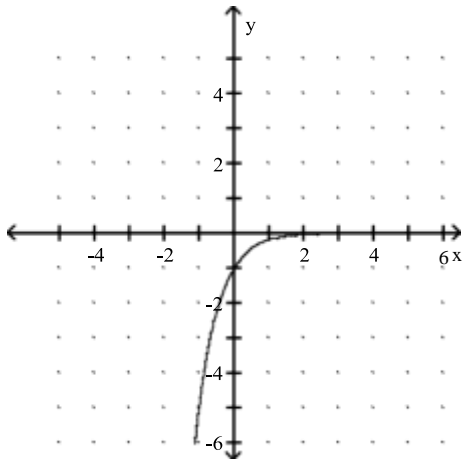

Answer: C

Solve the equation.

136) Solve for x: $3(1 + 2x) = 27$

- A) -1
- B) 9
- C) 1
- D) 3

Answer: C

137) Solve for x: $2^{4x} = 8^x + 5$

- A) 15
- B) -5
- C) -15
- D) 5

Answer: A

138) Solve for x: $(e^x)^x \cdot 27 = e^{12x}$

- A) {9}
- B) {-3, -9}
- C) {3, 9}
- D) {3}

Answer: C

139) Solve for t: $e^{-0.07t} = 0.05$ Round your answer to four decimal places.

- A) -66.4815
- B) 44.321
- C) 42.7962
- D) -70.1312

Answer: C

SHORT ANSWER. Write the word or phrase that best completes each statement or answers the question.

Solve the problem.

140) In the table below, the amount of the U.S. minimum wage is listed for selected years.

Year	1961	1967	1974	1980	1981	1990	1991	1996	1997
Wage	\$1.15	\$1.40	\$2.00	\$3.10	\$3.35	\$3.80	\$4.25	\$4.75	\$5.15

Find an exponential regression model of the form $y = a \cdot b^x$, where y represents the U.S. minimum wage x years after 1960. Round a and b to four decimal places. According to this model, what will the minimum wage be in 2005? In 2010?

Answer: $y = 1.1389(1.0429^x)$; \$7.54; \$9.30

MULTIPLE CHOICE. Choose the one alternative that best completes the statement or answers the question.

- 141) Hi-Tech UnWater begins a cable TV advertising campaign in Miami to market a new water. The percentage of the target market that buys water is estimated by the function $w(t) = 100(1 - e^{-0.02t})$, t represents the number of days of the campaign. After how long will 90% of the target market have bought the water?
- A) 120 days
 - B) 3 days
 - C) 90 days
 - D) 115 days

Answer: D

- 142) The number of books in a community college library increases according to the function $B = 7200e^{0.03t}$, where t is measured in years. How many books will the library have after 8 year(s)?
- A) 10,275
 - B) 9153
 - C) 4462
 - D) 7200

Answer: B

- 143) Since life expectancy has increased in the last century, the number of Alzheimer's patients has increased dramatically. The number of patients in the United States reached 4 million in 2000. Using data collected since 2000, it has been found that the data can be modeled by the exponential function $y = 4.19549 \cdot (1.02531)^x$, where x is the years since 2000. Estimate the Alzheimer's patients in 2025. Round to the nearest tenth.
- A) 8.0 million
 - B) 3.9 million
 - C) 4.8 million
 - D) 7.8 million

Answer: D

- 144) A sample of 800 grams of radioactive substance decays according to the function $A(t) = 800e^{-0.028t}$, where t is the time in years. How much of the substance will be left in the sample after 10 years? Round to the nearest whole gram.
- A) 1 gram
 - B) 605 grams
 - C) 9 grams
 - D) 800 grams

Answer: B

- 145) The number of reports of a certain virus has increased exponentially since 1960. The current number of cases can be approximated using the function $r(t) = 207e^{0.005t}$, where t is the number of years since 1960. Estimate the number of cases in the year 2010.
- A) 207
 - B) 190
 - C) 240
 - D) 266

Answer: D

- 146) An initial investment of \$12,000 is invested for 2 years in an account that earns 4% interest, compounded quarterly. Find the amount of money in the account at the end of the period.
- A) \$12,979.20
 - B) \$12,865.62
 - C) \$994.28
 - D) \$12,994.28

Answer: D

- 147) Suppose that \$2200 is invested at 3% interest, compounded semiannually. Find the function for the amount of money after t years.
- A) $A = 2200(1.015)^t$
 - B) $A = 2200(1.0125)^{2t}$
 - C) $A = 2200(1.015)^{2t}$
 - D) $A = 2200(1.03)^{2t}$

Answer: C

Use the REGRESSION feature on a graphing calculator.

- 148) A strain of E-coli Beu-recA441 is placed into a petri dish at 30°Celsius and allowed to grow. The following data are collected. Theory states that the number of bacteria in the petri dish will initially grow according to the law of uninhibited growth. The population is measured using an optical device in which the amount of light that passes through the petri dish is measured.

Time in hours, x	Population, y
0	0.09
2.5	0.18
3.5	0.26
4.5	0.35
6	0.50

Find the exponential equation in the form $y = a \cdot b^x$, where x is the hours of growth. Round to four decimal places.

- A) $y = 0.0903 \cdot 1.3384^x$
- B) $y = 0.0903^x$
- C) $y = 1.3384^x$
- D) $y = 1.3384 \cdot 0.0903^x$

Answer: A

- 149) The total cost of the Democratic and the Republican national conventions has increased 596% over the 20-year period between 1980 and 2004. The following table lists the total cost, in millions of dollars, for selected years.

Year, x	Cost, y
1980, x = 0	\$ 23.1
1984, x = 4	31.8
1988, x = 8	44.4
1992, x = 12	58.8
1996, x = 16	90.6
2000, x = 20	160.8
2004, x = 24	170.5

Find the exponential functions that best estimates this data. Round your answer to four decimal places

- A) $y = 1.0929 \cdot (22.2887)^x$
- B) $y = 6.6643x + 2.8857$
- C) $y = 22.2887 \cdot (1.0929)^x$
- D) $y = 22.2887x \cdot (1.0929)^x$

Answer: C

SHORT ANSWER. Write the word or phrase that best completes each statement or answers the question.

- 150) A particular bacterium is found to have a doubling time of 20 minutes. If a laboratory culture begins with a population of 300 of this bacteria and there is no change in the growth rate, how many bacteria will be present in 55 minutes? Use six decimal places in the interim calculation for the growth rate.

Answer: 2,018 bacteria

MULTIPLE CHOICE. Choose the one alternative that best completes the statement or answers the question.

Convert to a logarithmic equation.

151) $2^3 = 8$

- A) $\log_3 8 = 2$
- B) $\log_2 3 = 8$
- C) $\log_8 2 = 3$
- D) $\log_2 8 = 3$

Answer: D

152) $5^2 = 25$

- A) $5 = \log_2 25$
- B) $25 = \log_5 2$
- C) $2 = \log_5 25$
- D) $2 = \log_{25} 5$

Answer: C

153) $10^{0.4771} = 3$

- A) $0.4771 = \log 10$
- B) $0.4771 = \log_9 10$
- C) $3 = \log 0.4771$
- D) $0.4771 = \log 3$

Answer: D

154) $e^t = 7$

- A) $\log_7 t = e$
- B) $\ln t = 7$
- C) $\ln 7 = t$
- D) $\log_7 e = t$

Answer: B

Convert to an exponential equation.

155) $\log_9 27 = \frac{3}{2}$

- A) $27 = \left(\frac{3}{2}\right)^9$
- B) $9 = 27^{3/2}$
- C) $\frac{3}{2} = \sqrt[9]{27}$
- D) $27 = 9^{3/2}$

Answer: D

156) $\log_8 512 = t$

A) $8^t = 512$

B) $512^8 = t$

C) $t^8 = 512$

D) $8^{512} = t$

Answer: A

157) $\ln 44 = 3.7842$

A) $e^{3.7842} = 1$

B) $e^{3.7842} = 44$

C) $e^{3.7842} = \ln 44$

D) $e^{44} = 3.7842$

Answer: B

Evaluate.

158) $\log_8 8^4$

A) 32

B) 8

C) 8^4

D) 4

Answer: D

Use a calculator to evaluate the expression. Round the result to five decimal places.

159) $\log 0.17$

A) -4.07454

B) -1.76955

C) -0.76955

D) -1.77196

Answer: C

160) $\log 0.234$

A) -0.63074

B) -1.45243

C) 1.26364

D) 0.234

Answer: A

161) $\log 51.237$

A) 3.93646

B) 1.70958

C) 51.237

D) Undefined

Answer: B

- 162) $\log(-10.25)$
A) 1.01072
B) 2.32728
C) -1.01072
D) Undefined

Answer: D

- 163) $\log_8 36.8$
A) 1.56585
B) 3.60550
C) 1.73388
D) 0.57674

Answer: C

- 164) $\ln 0.027$
A) -1.56864
B) 0.56864
C) -3.61192
D) Undefined

Answer: C

- 165) $\ln 1097$
A) 9.30292
B) 7.00033
C) 3.04021
D) 4.69775

Answer: B

Write in terms of simpler forms.

- 166) $\log_6 XY$
A) $\log_3 X - \log_3 Y$
B) $\log_3 X + \log_3 Y$
C) $\log_6 X - \log_6 Y$
D) $\log_6 X + \log_6 Y$

Answer: D

- 167) $\log_{\frac{a}{b}} s$
A) $\log_{\frac{a}{2b}} s$
B) $\log_b a + \log_b s$
C) $\log_b a - s$
D) $\log_b a - \log_b s$

Answer: D

- 168) $\log_b M^9$
A) $9 + \log_b M$
B) $M \log_b 9$
C) $9 \log_b M$
D) $M + \log_b 9$

Answer: C

- 169) ${}_4^a \log_4 b$
A) b^{4a}
B) b^a
C) a^b
D) a^{4b}

Answer: B

Solve for x to two decimal places (using a calculator).

- 170) $700 = 500(1.04)^x$
A) 8.58
B) 520
C) 1.35
D) 1.40

Answer: A

- 171) $5.2 = 1.006^{12x}$
A) 22.97
B) 2.32
C) 1.07
D) 5.17

Answer: A

Use the properties of logarithms to solve.

- 172) $\log_7 x + \log_7(x - 2) = \log_7 24$
A) 7
B) 2
C) 6
D) 24

Answer: C

- 173) $\log_b x - \log_b 5 = \log_b 2 - \log_b(x - 3)$
A) 2, 5
B) 3
C) 2
D) 5

Answer: D

174) $\log_b(x + 3) + \log_b x = \log_b 54$

- A) -6
- B) 3
- C) -6, -3
- D) 6

Answer: D

175) $\log_6(4x - 5) = 1$

- A) $\frac{\log 5}{4}$
- B) $\frac{11}{4}$
- C) $\frac{7}{4}$
- D) $\frac{11}{6}$

Answer: B

176) $\ln(3x - 4) = \ln 20 - \ln(x - 5)$

- A) -5, $-\frac{19}{3}$
- B) $\frac{19}{3}$
- C) 5, $\frac{5}{3}$
- D) 0, $\frac{19}{3}$

Answer: B

177) $\log(x + 10) - \log(x + 4) = \log x$

- A) -5
- B) 2, -5
- C) 6
- D) 2

Answer: D

178) $\log(x - 9) = 1 - \log x$

- A) -10, 1
- B) -10
- C) 10
- D) -1, 10

Answer: C

Graph by converting to exponential form first.

179) $y = \log_5 (x - 4)$

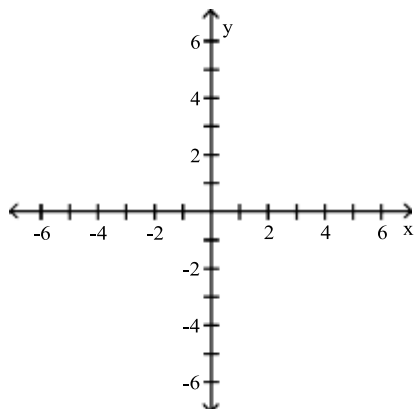

A)

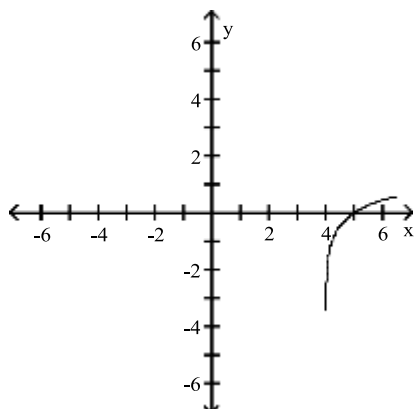

B)

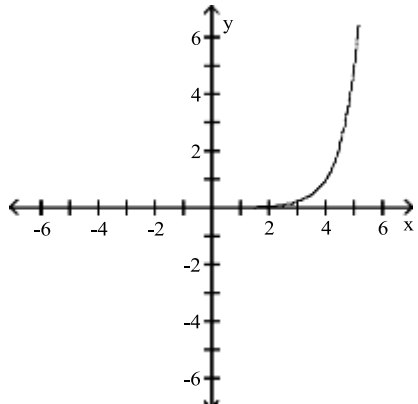

C)

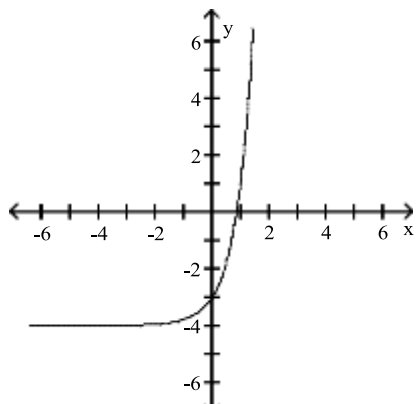

D)

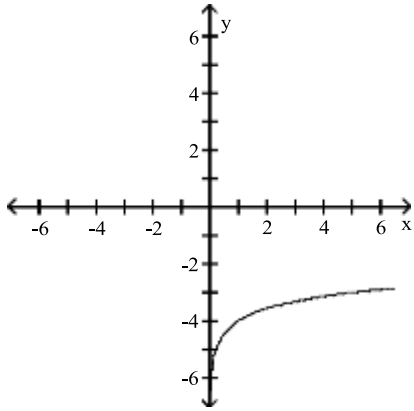

Answer: A

180) $y = \log_5(x + 2)$

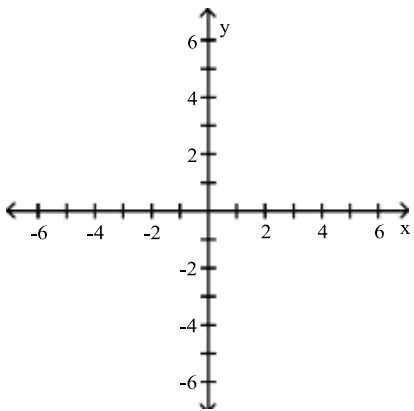

A)

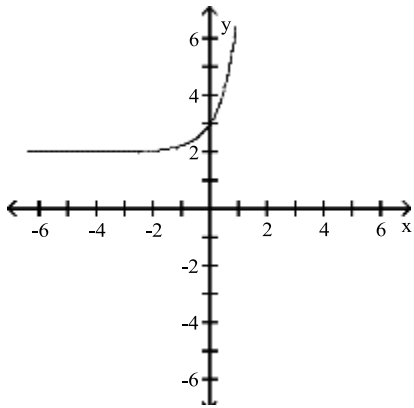

B)

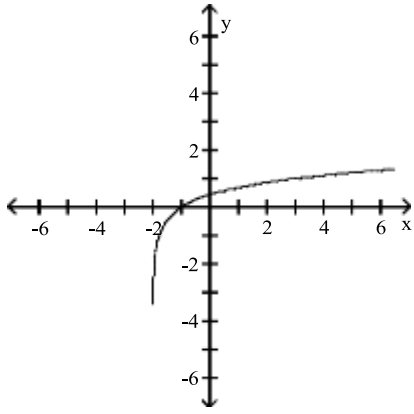

C)

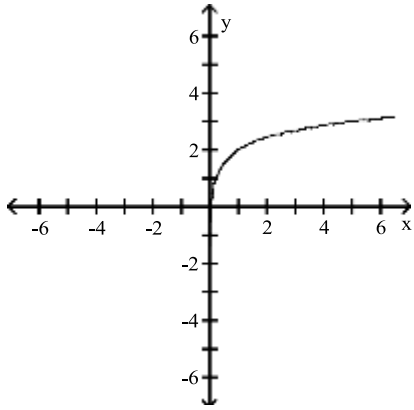

D)

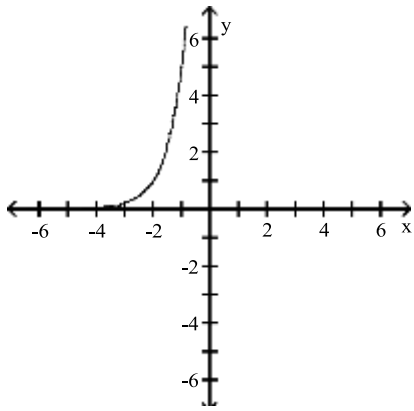

Answer: B

Graph the function using a calculator and point-by-point plotting. Indicate increasing and decreasing intervals.

181) $f(x) = 3 \ln x$

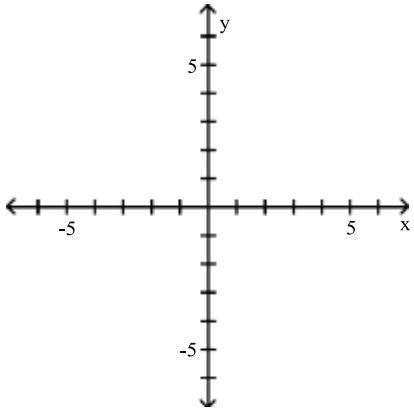

A) Decreasing: $(0, \infty)$

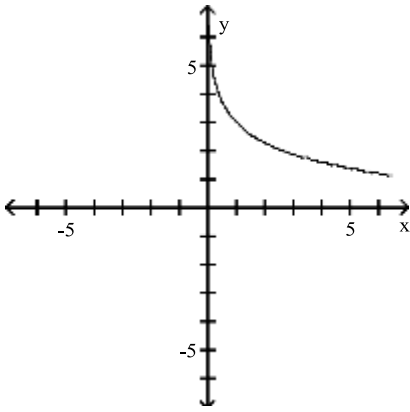

B) Increasing: $(-3, \infty)$

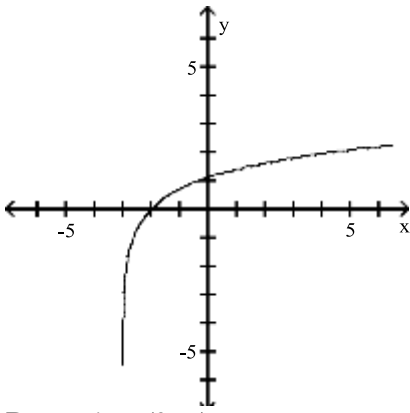

C) Decreasing: $(0, \infty)$

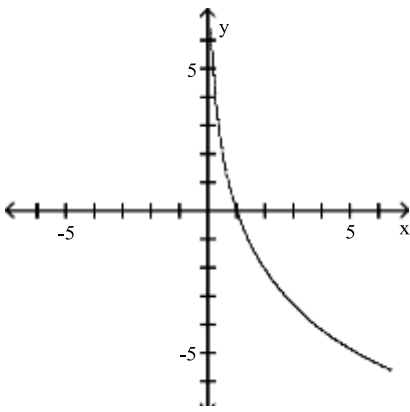

D) Increasing: $(0, \infty)$

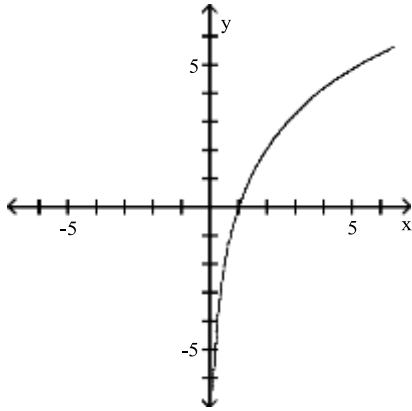

Answer: D

182) $f(x) = |-4 \ln x|$

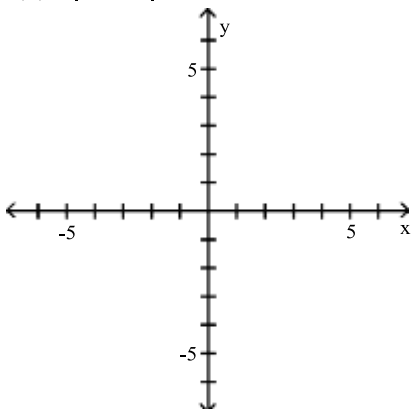

A) Decreasing: $(0, \infty)$

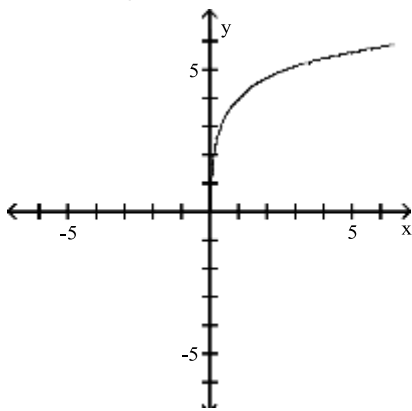

B) Decreasing: $(0, 1]$

Increasing: $[1, \infty)$

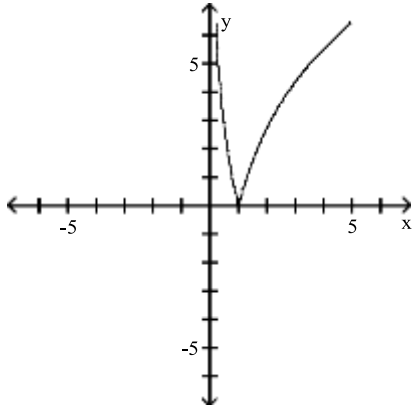

C) Decreasing: $(0, -4]$

Increasing: $[-4, \infty)$

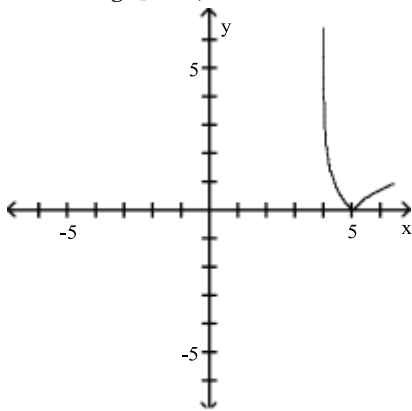

D) Decreasing: $(0, \frac{1}{2}]$

Increasing: $[\frac{1}{2}, \infty)$

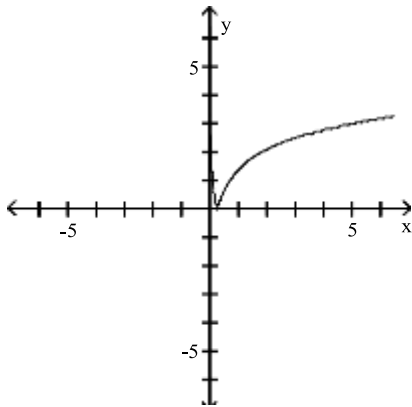

Answer: B

183) $f(x) = -3 - \ln x$

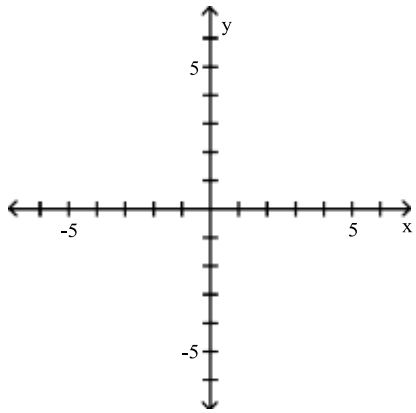

A) Decreasing: $(0, \infty)$

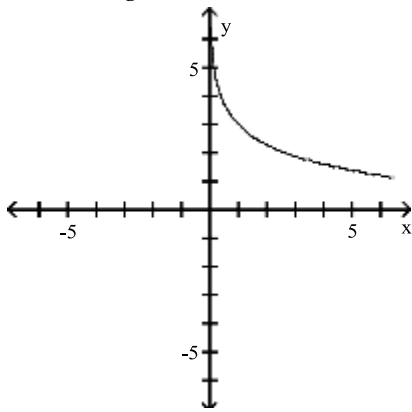

B) Increasing $(0, \infty)$

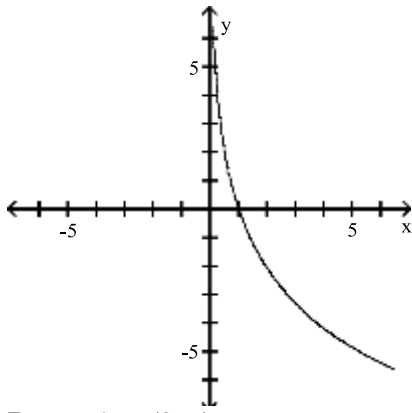

C) Decreasing: $(0, \infty)$

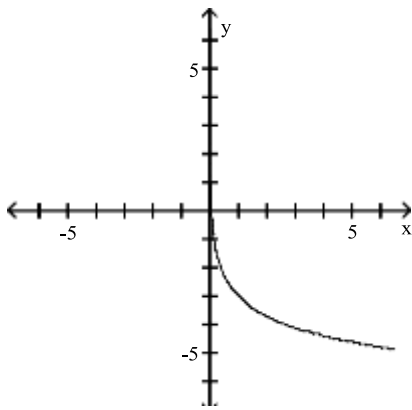

D) Increasing $(-3, \infty)$

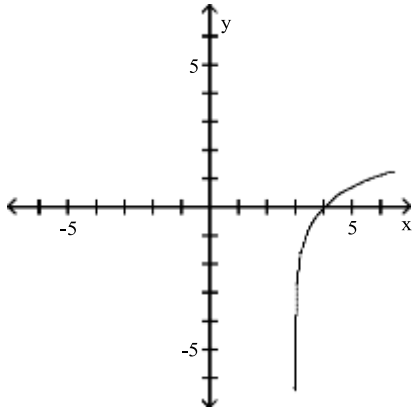

Answer: C

184) $f(x) = 2 - \ln(x + 4)$

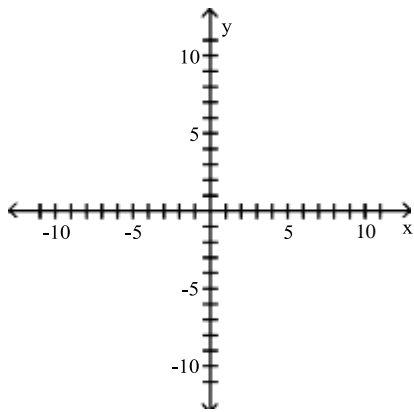

A) Decreasing: $(4, \infty)$

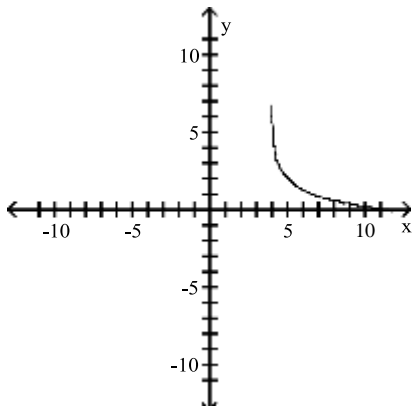

B) Decreasing: $(-4, \infty)$

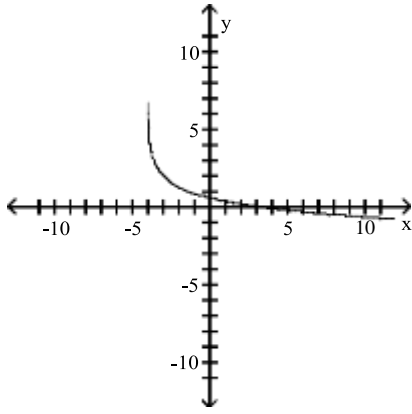

C) Decreasing: $(-4, \infty)$

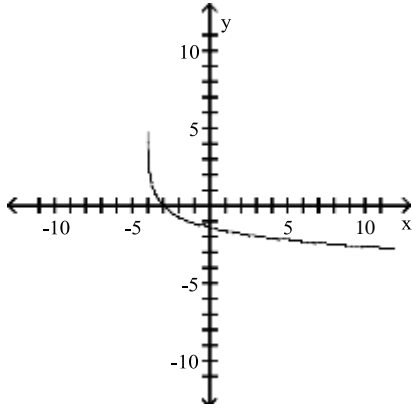

D) Decreasing: $(0, \infty)$

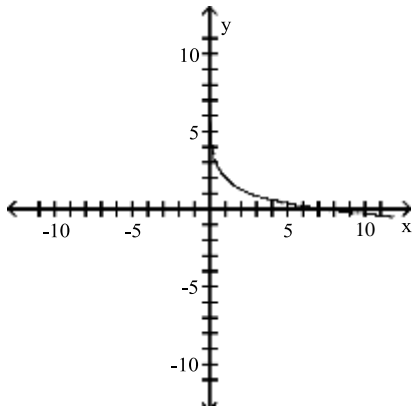

Answer: B

Solve the problem.

185) If \$1250 is invested at a rate of $8\frac{1}{4}\%$ compounded monthly, what is the balance after 10 years?

$[A = P(1 + i)^n]$

- A) \$2281.25
- B) \$1031.25
- C) \$2844.31
- D) \$1594.31

Answer: C

186) If \$4,000 is invested at 7% compounded annually, how long will it take for it to grow to \$6,000, assuming no withdrawals are made? Compute answer to the next higher year if not exact.

$$[A = P(1 + r)^t]$$

- A) 2 years
- B) 8 years
- C) 6 years
- D) 5 years

Answer: C

187) In North America, coyotes are one of the few species with an expanding range. The future population of coyotes in a region of Mississippi valley can be modeled by the equation $P = 59 + 12 \cdot \ln(18t + 1)$, where t is time in years. Use the equation to determine when the population will reach 170. (Round your answer to the nearest tenth year.)

- A) 583.1 years
- B) 581.3 years
- C) 578.0 years
- D) 586.2 years

Answer: C

188) A country has a population growth rate of 2.4% compounded continuously. At this rate, how long will it take for the population of the country to double? Round your answer to the nearest tenth.

- A) 2.9 years
- B) 30 years
- C) .29 years
- D) 28.9 years

Answer: D

189) A carbon-14 dating test is performed on a fossil bone, and analysis finds that 15.5% of the original amount of carbon-14 is still present in the bone. Estimate the age of the fossil bone. (Recall that carbon-14 decays according to the equation $A = A_0e^{-0.000124t}$).

- A) 15,000 years
- B) 15,035 years
- C) 1,500 years
- D) 150 years

Answer: B

190) Assume that a savings account earns interest at the rate of 2% compounded monthly. If this account contains \$1000 now, how many months will it take for this amount to double if no withdrawals are made?

- A) 408 months
- B) 417 months
- C) 12 months
- D) 450 months

Answer: B

- 191) U. S. Census Bureau data shows that the number of families in the United States (in millions) in year x is given by $h(x) = 51.42 + 15.473 \cdot \log x$, where $x = 0$ is 1980. How many families were there in 2002?
- A) 21 million
 - B) 48 million
 - C) 72 million
 - D) 90 million

Answer: C

- 192) The level of a sound in decibels (db) is determined by the formula $N = 10 \cdot \log(I \times 10^{12})$ db, where I is the intensity of the sound in watts per square meter. A certain noise has an intensity of 8.49×10^{-4} watts per square meter. What is the sound level of this noise? (Round your answer to the nearest decibel.)
- A) 9 db
 - B) 206 db
 - C) 89 db
 - D) 79 db

Answer: C

- 193) Book sales on the Internet (in billions of dollars) in year x are approximated by $f(x) = 1.84 + 2.1 \cdot \ln x$, where $x = 0$ corresponds to 2000. How much will be spent on Internet book sales in 2008? Round to the nearest tenth.
- A) 8.0 billion
 - B) 3.9 billion
 - C) 6.0 billion
 - D) 6.2 billion

Answer: D