

Manufacturing Processes for Engineering Materials 6th Edition Kalpakjian

**Solution Manual for Manufacturing
Processes for Engineering Materials 6th
Edition Kalpakjian Schmid 0134290550
9780134290553**

Full link download:

<https://testbankpack.com/p/solution-manual-for-manufacturing-processes-for-engineering-materials-6th-edition-kalpakjian-schmid-0134290550-9780134290553/>

Chapter 2

Fundamentals of the Mechanical Behavior of Materials

QUESTIONS

- 2.1 Can you calculate the percent elongation of materials based only on the information given in Fig. 2.6? Explain.

Recall that the percent elongation is defined by Eq. (2.6) on p. 35 and depends on the original gage length (l_0) of the specimen. From Fig. 2.6 on p. 39, only the necking strain (true and engineering) and true fracture strain can be determined. Thus, we cannot calculate the percent elongation of the specimen; also, note that the elongation is a function of gage length and increases with gage length.

- 2.2 Explain if it is possible for stress-strain curves in tension tests to reach 0% elongation as the gage length is increased further.

The percent elongation of the specimen is a function of the initial and final gage lengths. When the specimen is being pulled, regardless of the original gage length, it will elongate uniformly (and permanently) until necking begins. Therefore, the specimen will always have a certain finite elongation. However, note that as the specimen's gage length is increased, the contribution of localized elongation (that is, necking) will decrease, but the total elongation will not approach zero.

- 2.3 Explain why the difference between engineering strain and true strain becomes larger as strain increases. Is this phenomenon true for both tensile and compressive strains? Explain.

The difference between the engineering and true strains becomes larger because of the way the strains are defined, respectively, as can be seen by inspecting Eqs. (2.1) and (2.9). This is true for both tensile and compressive strains.

- 2.4 Using the same scale for stress, the tensile true-stress-true-strain curve is higher than the engineering stress-

strain curve. Explain whether this condition also holds for a compression test.

During a compression test, the cross-sectional area of the specimen increases as the specimen height decreases (because of volume constancy) as the load is increased. Since true stress is defined as ratio of the load to the instantaneous cross-sectional area of the specimen, the true stress in compression will be lower than the engineering stress for a given load, assuming that friction between the platens and the specimen is negligible.

- 2.5 Which of the two tests, tension or compression, requires a higher capacity testing machine than the other? Explain.

The compression test requires a higher capacity machine because the cross-sectional area of the specimen increases during the test, which is the opposite of a tension test. The increase in area requires a load higher than that for the tension test to achieve the same stress level. Furthermore, note that compression-test specimens generally have a larger original cross-sectional area than those for tension tests, thus requiring higher forces.

- 2.6 Explain how the modulus of resilience of a material changes, if at all, as it is strained: (a) for an elastic, perfectly plastic material, and (b) for an elastic, linearly strain-hardening material.

Recall that the modulus of resilience is given by Eq. (2.5) on p. 34 as $S_y^2/(2E)$. (a) If the material is perfectly plastic, then the yield strength does not increase with strain - see Fig. 2.7c on p. 42. Therefore, the modulus of resilience is unchanged as the material is strained. (b) For a linear strain hardening material, the yield strength increases with plastic strain. Therefore the modulus of resilience will increase with strain.

2.7 If you pull and break a tensile-test specimen rapidly, where would the temperature be the highest? Explain why.

Since temperature rise is due to the work input, the temperature will be highest in the necked region because that is where the strain, hence the energy dissipated per unit volume in plastic deformation, is highest.

2.8 Comment on the temperature distribution if the specimen in Question 2.7 is pulled very slowly.

If the specimen is pulled very slowly, the temperature generated will be dissipated throughout the specimen and to the environment. Thus, there will be no appreciable temperature rise anywhere, particularly with materials with high thermal conductivity.

2.9 In a tension test, the area under the true-stress-true-strain curve is the work done per unit volume (the specific work). Also, the area under the load-elongation curve represents the work done on the specimen. If you divide this latter work by the volume of the specimen between the gage marks, you will determine the work done per unit volume (assuming that all deformation is confined between the gage marks). Will this specific work be the same as the area under the true-stress-true-strain curve? Explain. Will your answer be the same for any value of strain? Explain.

If we divide the work done by the total volume of the specimen between the gage lengths, we obtain the average specific work throughout the specimen. However, the area under the true stress-true strain curve represents the specific work done at the necked (and fractured) region in the specimen where the strain is a maximum. Thus, the answers will be different. However, up to the onset of necking (instability), the specific work calculated will be the same. This is because the strain is uniform throughout the specimen until necking begins.

2.10 The note at the bottom of Table 2.4 states that as temperature increases, C decreases and m increases. Explain why.

The value of C in Table 2.4 on p. 46 decreases with temperature because it is a measure of the strength of the material. The value of m increases with temperature because the material becomes more strain-rate sensitive, due to the fact that the higher the strain rate, the less time the material has to recover and recrystallize, hence its strength increases.

2.11 You are given the K and n values of two different materials. Is this information sufficient to determine which material is tougher? If not, what additional information do you need, and why?

Although the K and n values may give a good estimate of toughness, the true fracture stress and the true strain at fracture are required for accurate calculation

of toughness. The modulus of elasticity and yield stress would provide information about the area under the elastic region; however, this region is very small and is thus usually negligible with respect to the rest of the stress-strain curve.

2.12 Modify the curves in Fig. 2.7 to indicate the effects of temperature. Explain your changes.

These modifications can be made by lowering the slope of the elastic region and lowering the general height of the curves. See, for example, Fig. 2.9 on p. 43.

2.13 Using a specific example, show why the deformation rate, say in m/s, and the true strain rate are not the same.

The deformation rate is the quantity v in Eqs. (2.16) and (2.17). Thus, when v is held constant during deformation (hence a constant deformation rate), the true strain rate will vary (l increases), whereas the engineering strain rate will remain constant. Hence, the two quantities are not the same.

2.14 It has been stated that the higher the value of m , the more diffuse the neck is, and likewise, the lower the value of m , the more localized the neck is. Explain the reason for this behavior.

As discussed in Section 2.2.7, with high m values, the material stretches to a greater length before it fails; this behavior is an indication that necking is delayed with increasing m . When necking is about to begin, the necking region's strength with respect to the rest of the specimen increases, due to strain hardening. However, the strain rate in the necking region is also higher than in the rest of the specimen, because the material is elongating faster there. Since the material in the necked region becomes stronger as it is strained at a higher rate, the region exhibits a greater resistance to necking. The increase in resistance to necking thus depends on the magnitude of m . As the tension test progresses, necking becomes more diffuse, and the specimen becomes longer before fracture; hence, total elongation increases with increasing values of m . As expected, the elongation after necking (postuniform elongation) also increases with increasing m . It has been observed that the value of m decreases with metals of increasing strength.

2.15 Explain why materials with high m values, such as hot glass and silly putty, when stretched slowly, undergo large elongations before failure. Consider events taking place in the necked region of the specimen.

The answer is similar to Answer 2.14 above.

2.16 Assume that you are running four-point bending tests on a number of identical specimens of the same length and cross-section, but with increasing distance between the upper points of loading (see Fig. 2.19b). What changes, if any, would you expect in the test results? Explain.

As the distance between the upper points of loading in Fig. 2.19b increases, the magnitude of the bending moment decreases. However, the volume of material subjected to the maximum bending moment (hence to maximum stress) increases. Thus, the probability of failure in the four-point test increases as this distance increases.

2.17 Would Eq. (2.10) hold true in the elastic range? Explain.

Note that this equation is based on volume constancy, i.e., $A_0 l_0 = A l$. We know, however, that because the Poisson's ratio ν is less than 0.5 in the elastic range, the volume is not constant in a tension test; see Eq. (2.47) on p. 71. Therefore, the expression is not valid in the elastic range.

2.18 Why have different types of hardness tests been developed? How would you measure the hardness of a very large object?

There are several basic reasons:

1. The overall hardness range of the materials
2. The hardness of their constituents; see Chapter 3;
3. The thickness of the specimen, such as bulk versus foil
4. The size of the specimen with respect to that of the indenter
5. The surface finish of the part being tested.

2.19 Which hardness tests and scales would you use for very thin strips of material, such as aluminum foil? Why?

Because aluminum foil is very thin, the indentations on the surface must be very small so as not to affect test results. Suitable tests would be a microhardness test such as Knoop or Vickers under very light loads (see Fig. 2.20 on p. 54). The accuracy of the test can be validated by observing any changes in the surface appearance opposite to the indented side.

2.20 List and explain the factors that you would consider in selecting an appropriate hardness test and scale for a particular application.

Hardness tests mainly have three differences:

1. type of indenter,
2. applied load, and
3. method of indentation measurement (depth or surface area of indentation, or rebound of indenter).

2.21 In a Brinell hardness test, the resulting impression is found to be an ellipse. Give possible explanations for this result.

There are several possible reasons for this phenomenon, but the two most likely are anisotropy in the material and the presence of surface residual stresses in the material.

2.22 Referring to Fig. 2.20, the material for testers are either steel, tungsten carbide, or diamond. Why isn't diamond used for all of the tests?

While diamond is the hardest material known, it would not, for example, be practical to make and use a 10-mm diamond indenter because the costs would be prohibitive. Consequently, a hard material such as those listed are sufficient for most hardness tests.

2.23 What role does friction play in a hardness test? Can high friction between a material and indenter affect a hardness test? Explain.

The effect of friction has been found to be minimal. In a hardness test, most of the indentation occurs through plastic deformation, and there is very little sliding at the indenter-workpiece interface; see Fig. 2.23 on p. 58.

2.24 Describe the difference between creep and stress relaxation, giving two examples for each as they relate to engineering applications.

Creep is the permanent deformation of a part that is under a load over a period of time, usually occurring at elevated temperatures. Stress relaxation is the decrease in the stress level in a part under a constant strain. Examples of creep include:

1. turbine blades operating at high temperatures, and
2. high-temperature steam lines and furnace components.

Stress relaxation is observed when, for example, a rubber band or a thermoplastic is pulled to a specific length and held at that length for a period of time. This phenomenon is commonly observed in rivets, bolts, and guy wires, as well as thermoplastic components.

2.25 Referring to the two impact tests shown in Fig. 2.26, explain how different the results would be if the specimens were impacted from the opposite directions.

Note that impacting the specimens shown in Fig. 2.26 on p. 61 from the opposite directions would subject the roots of the notches to compressive stresses, and thus they would not act as stress raisers. Thus, cracks would not propagate as they would when under tensile stresses. Consequently, the specimens would basically behave as if they were not notched.

2.26 If you remove the layer ad from the part shown in Fig. 2.27d, such as by machining or grinding, which way will the specimen curve? (Hint: Assume that the part in diagram (d) is composed of four horizontal springs held at the ends. Thus, from the top down, we have compression, tension, compression, and tension springs.)

Since the internal forces will have to achieve a state of static equilibrium, the new part has to bow downward (i.e., it will hold water). Such residual-stress patterns

can be modeled with a set of horizontal tension and compression springs. Note that the top layer of the material in Fig. 2.27d, which is under compression, has the tendency to bend the bar upward. When this stress is relieved (such as by removing a layer), the bar will compensate for it by bending downward.

2.27 Is it possible to completely remove residual stresses in a piece of material by the technique described in Fig. 2.29 if the material is elastic, linearly strain hardening? Explain.

By following the sequence of events depicted in Fig. 2.29 on p. 64, it can be seen that it is not possible to completely remove the residual stresses. Note that for an elastic, linearly strain hardening material, σ_c will never catch up with σ_t .

2.28 Referring to Fig. 2.29, would it be possible to eliminate residual stresses by compression? Assume that the piece of material will not buckle under the uniaxial compressive force.

Yes, by the same mechanism described in Fig. 2.29 on p. 64.

2.29 List and explain the desirable mechanical properties for (a) an elevator cable; (b) a bandage; (c) a shoe sole; (d) a fish hook; (e) an automotive piston; (f) a boat propeller; (g) a gas-turbine blade; and (h) a staple.

The following are some basic considerations:

- (a) Elevator cable: The cable should not elongate elastically to a large extent or undergo yielding as the load is increased. These requirements thus call for a material with a high elastic modulus and yield stress.
- (b) Bandage: The bandage material must be compliant, that is, have a low stiffness, but have high strength in the membrane direction. Its inner surface must be permeable and outer surface resistant to environmental effects.
- (c) Shoe sole: The sole should be compliant for comfort, with a high resilience. It should be tough so that it absorbs shock and should have high friction and wear resistance.
- (d) Fish hook: A fish hook needs to have high strength so that it doesn't deform permanently under load, and thus maintain its shape. It should be stiff (for better control during its use) and should be resistant to the environment it is used in (such as salt water).
- (e) Automotive piston: This product must have high strength at elevated temperatures, high physical and thermal shock resistance, and low mass.
- (f) Boat propeller: The material must be stiff (to maintain its shape) and resistant to corrosion, and also have abrasion resistance because the propeller encounters sand and other abrasive particles when operated close to shore.

(g) Gas turbine blade: A gas turbine blade operates at high temperatures (depending on its location in the turbine); thus it should have high-temperature strength and resistance to creep, as well as to oxidation and corrosion due to combustion products during its use.

(h) Staple: The properties should be closely parallel to that of a paper clip. The staple should have high ductility to allow it to be deformed without fracture, and also have low yield stress so that it can be bent (as well as unbent when removing it) easily without requiring excessive force.

2.30 Make a sketch showing the nature and distribution of the residual stresses in Figs. 2.28a and b before the parts were cut. Assume that the split parts are free from any stresses. (Hint: Force these parts back to the shape they were in before they were cut.)

As the question states, when we force back the split portions in the specimen in Fig. 2.28a on p. 63, we induce tensile stresses on the outer surfaces and compressive on the inner. Thus the original part would, along its total cross section, have a residual stress distribution of tension-compression-tension. Using the same technique, we find that the specimen in Fig. 2.28b would have a similar residual stress distribution prior to cutting.

2.31 It is possible to calculate the work of plastic deformation by measuring the temperature rise in a workpiece, assuming that there is no heat loss and that the temperature distribution is uniform throughout? If the specific heat of the material decreases with increasing temperature, will the work of deformation calculated using the specific heat at room temperature be higher or lower than the actual work done? Explain.

If we calculate the heat using a constant specific heat value in Eq. (2.62), the work will be higher than it actually is. This is because, by definition, as the specific heat decreases, less work is required to raise the workpiece temperature by one degree. Consequently, the calculated work will be higher than the actual work done.

2.32 Explain whether or not the volume of a metal specimen changes when the specimen is subjected to a state of (a) uniaxial compressive stress and (b) uniaxial tensile stress, all in the elastic range.

For case (a), the quantity in parentheses in Eq. (2.47) on p. 71 will be negative, because of the compressive stress. Since the rest of the terms are positive, the product of these terms is negative and, hence, there will be a decrease in volume (This can also be deduced intuitively.) For case (b), it will be noted that the volume will increase.

2.33 It is relatively easy to subject a specimen to hydrostatic compression, such as by using a chamber filled with a liquid. Devise a means whereby the specimen (say, in

the shape of a cube or a round disk) can be subjected to hydrostatic tension, or one approaching this state of stress. (Note that a thin-walled, internally pressurized spherical shell is not a correct answer, because it is subjected only to a state of plane stress.)

Two possible answers are the following:

1. A solid cube made of a soft metal has all its six faces brazed to long square bars (of the same cross section as the specimen); the bars are made of a stronger metal. The six arms are then subjected to equal tension forces, thus subjecting the cube to equal tensile stresses.
2. A thin, solid round disk (such as a coin) and made of a soft material is brazed between the ends of two solid round bars of the same diameter as that of the disk. When subjected to longitudinal tension, the disk will tend to shrink radially. But because it is thin and its flat surfaces are restrained by the two rods from moving, the disk will be subjected to tensile radial stresses. Thus, a state of triaxial (though not exactly hydrostatic) tension will exist within the thin disk.

2.34 Referring to Fig. 2.17, make sketches of the state of stress for an element in the reduced section of the tube when it is subjected to (a) torsion only; (b) torsion while the tube is internally pressurized; and (c) torsion while the tube is externally pressurized. Assume that the tube is a closed-end tube.

These states of stress can be represented simply by referring to the contents of this chapter as well as the relevant materials covered in texts on mechanics of solids.

2.35 A penny-shaped piece of soft metal is brazed to the ends of two flat, round steel rods of the same diameter as the piece. The assembly is then subjected to uniaxial tension. What is the state of stress to which the soft metal is subjected? Explain.

The penny-shaped soft metal piece will tend to contract radially due to Poisson's ratio; however, the solid rods to which it attached will prevent this from happening. Consequently, the state of stress will tend to approach that of hydrostatic tension.

2.36 A circular disk of soft metal is being compressed between two flat, hardened circular steel punches of having the same diameter as the disk. Assume that the disk material is perfectly plastic and that there is no friction or any temperature effects. Explain the change, if any, in the magnitude of the punch force as the disk is being compressed plastically to, say, a fraction of its original thickness.

Note that as it is compressed plastically, the disk will expand radially, because of volume constancy. An approximately donut-shaped material will then be pushed radially outward, which will then exert radial compressive stresses on the disk volume under

the punches. The volume of material directly between the punches will now be subjected to a triaxial compressive state of stress. According to yield criteria (see Section 2.11), the compressive stress exerted by the punches will thus increase, even though the material is not strain hardening. Therefore, the punch force will increase as deformation increases.

2.37 A perfectly plastic metal is yielding under the stress state $\sigma_1, \sigma_2, \sigma_3$, where $\sigma_1 > \sigma_2 > \sigma_3$. Explain what happens if σ_1 is increased.

Consider Fig. 2.32 on p. 70. Points in the interior of the yield locus are in an elastic state, whereas those on the yield locus are in a plastic state. Points outside the yield locus are not admissible. Therefore, an increase in σ_1 while the other stresses remain unchanged would require an increase in yield stress. This can also be deduced by inspecting either Eq. (2.38) or Eq. (2.39).

2.38 What is the dilatation of a material with a Poisson's ratio of 0.5? Is it possible for a material to have a Poisson's ratio of 0.7? Give a rationale for your answer.

It can be seen from Eq. (2.47) on p. 71 that the dilatation of a material with $\nu = 0.5$ is always zero, regardless of the stress state. To examine the case of $\nu = 0.7$, consider the situation where the stress state is hydrostatic tension. Equation (2.47) would then predict contraction under a tensile stress, a situation that cannot occur.

2.39 Can a material have a negative Poisson's ratio? Give a rationale for your answer.

Solid materials do not have a negative Poisson's ratio, with the exception of some composite materials (see Chapter 10), where there can be a negative Poisson's ratio in a given direction.

2.40 As clearly as possible, define plane stress and plane strain.

Plane stress is the situation where the stresses in one of the directions on an element are zero; plane strain is the situation where the strains in one of the directions are zero.

2.41 What test would you use to evaluate the hardness of a coating on a metal surface? Would it matter if the coating was harder or softer than the substrate? Explain.

The answer depends on whether the coating is relatively thin or thick. For a relatively thick coating, conventional hardness tests can be conducted, as long as the deformed region under the indenter is less than about one-tenth of the coating thickness. If the coating thickness is less than this threshold, then one must either rely on nontraditional hardness tests, or else use fairly complicated indentation models to extract the material behavior. As an example of the former, atomic force microscopes using diamond-tipped pyramids have been used to measure the hardness of coatings less than 100 nanometers thick. As an example of

the latter, finite-element models of a coated substrate being indented by an indenter of a known geometry can be developed and then correlated to experiments.

2.42 List the advantages and limitations of the stress-strain relationships given in Fig. 2.7.

Several answers that are acceptable, and the student is encouraged to develop as many as possible. Two possible answers are:

1. There is a tradeoff between mathematical complexity and accuracy in modeling material behavior
2. Some materials may be better suited for certain constitutive laws than others

2.43 Plot the data in the inside front cover on a bar chart, showing the range of values, and comment on the results.

By the student. An example of a bar chart for the elastic modulus is shown below.

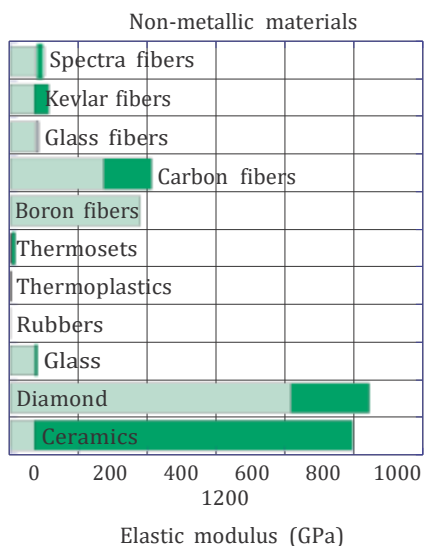
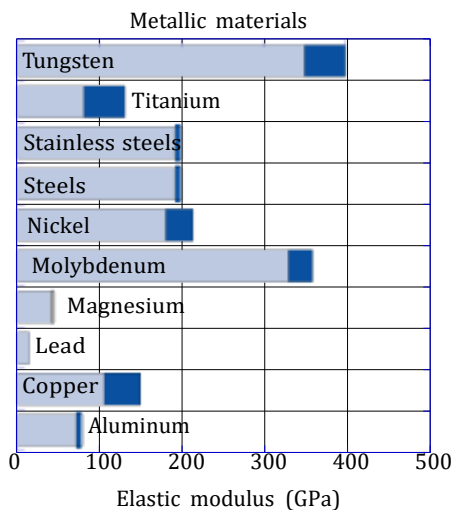

Typical comments regarding such a chart are:

1. There is a smaller range for metals than for non-metals;
2. Thermoplastics, thermosets and rubbers are orders of magnitude lower than metals and other non-metals;
3. Diamond and ceramics can be superior to others, but ceramics have a large range of values.

2.44 A hardness test is conducted on as-received metal as a quality check. The results show indicate that the hardness is too high, indicating that the material may not have sufficient ductility for the intended application. The supplier is reluctant to accept the return of the material, instead claiming that the diamond cone used in the Rockwell testing was worn and blunt, and hence the test needed to be recalibrated. Is this explanation plausible? Explain.

Refer to Fig. 2.20 on p. 54 and note that if an indenter is blunt, then the penetration, t , under a given load will be smaller than that using a sharp indenter. This then translates into a higher hardness. The explanation is plausible, but in practice, hardness tests are fairly reliable and measurements are consistent if the testing equipment is properly calibrated and routinely serviced.

2.45 Explain why a 0.2% offset is used to obtain the yield strength in a tension test.

The value of 0.2% is somewhat arbitrary and is used to set some standard. A yield stress, representing the transition point from elastic to plastic deformation, is difficult to measure. This is because the stress-strain curve is not linearly proportional after the proportional limit, which can be as high as one-half the yield strength in some metals. Therefore, a transition from elastic to plastic behavior in a stress-strain curve is difficult to discern. The use of a 0.2% offset is a convenient way of consistently interpreting a yield point from stress-strain curves.

2.46 Referring to Question 2.45, would the offset method be necessary for a highly strained hardened material? Explain.

The 0.2% offset is still advisable whenever it can be used, because it is a standardized approach for determining yield stress, and thus one should not arbitrarily abandon standards. However, if the material is highly cold worked, there will be a more noticeable 'kink' in the stress-strain curve, and thus the yield stress is far more easily discernable than for the same material in the annealed condition.

2.47 Explain why the hardness of a material is related to a multiple of the uniaxial compressive stress, since both involve compression of workpiece material.

The hardness is related to a multiple of the uniaxial compressive stress, not just the uniaxial compressive stress, because:

1. The volume of material that is stressed is different - in a hardness test, the volume that is under stress is not just a cylinder beneath the inventor.
2. The stressed volume is constrained by the elastic material outside of the indentation area. This often requires material to deform laterally and counter to the indentation direction - see Fig. 2.21

2.48 Without using the words “stress” or “strain”, define elastic modulus.

This is actually quite challenging, but historically sig-

nificant, since Thomas Young did not have the benefit of the concept of strain when he first defined modulus of elasticity. Young’s definition satisfies the project requirement. In Young’s words:

The modulus of the elasticity of any substance is a column of the same substance, capable of producing a pressure on its base which is to the weight causing a certain degree of compression as the length of the substance is to the diminution of the length.

There are many possible other definitions, of course.

PROBLEMS

2.49 A strip of metal is originally 1.0 m long. It is stretched in three steps: first to a length of 1.5 m, then to 2.5 m, and finally to 3.0 m. Show that the total true strain is the sum of the true strains in each step, that is, that the strains are additive. Show that, using engineering strains, the strain for each step cannot be added to obtain the total strain.

The true strain is given by Eq. (2.9) on p. 36 as

$$= \ln \frac{l}{l_0}$$

Therefore, the true strains for the three steps are:

$$e_1 = \ln \frac{1.5}{1.0} = 0.4055$$

$$e_2 = \ln \frac{2.5}{1.5} = 0.5108$$

$$e_3 = \ln \frac{3.0}{2.5} = 0.1823$$

The sum of these true strains is $e = 0.4055 + 0.5108 + 0.1823 = 1.099$. The true strain from step 1 to 3 is

$$e = \ln \frac{3}{1} = 1.099$$

Therefore the true strains are additive. Using the same approach for engineering strain as defined by Eq. (2.1),

we obtain $e_1 = 0.5$, $e_2 = 0.667$, and $e_3 = 0.20$. The sum of these strains is $e_1 + e_2 + e_3 = 1.367$. The engineering strain from step 1 to 3 is

$$e = \frac{l - l_0}{l_0} = \frac{3 - 1}{1} = 2$$

$$\begin{aligned} l_0 &= 1; \\ l_1 &= 1.5; \\ l_2 &= 2.5; \\ l_3 &= 3; \\ e_{tot} &= (l_1 - l_0)/l_0 + (l_2 - l_1)/l_1 + (l_3 - l_2)/l_2; \\ e_{fin} &= (l_3 - l_0)/l_0; \\ e_{pstot} &= \log(l_1/l_0) + \log(l_2/l_1) + \log(l_3/l_2); \\ e_{psfin} &= \log(l_3/l_0); \end{aligned}$$

2.50 A paper clip is made of wire 1.00 mm in diameter. If the original material from which the wire is made is a rod 15 mm in diameter, calculate the longitudinal and diametrical engineering and true strains that the wire has undergone during processing.

Assuming volume constancy, we may write

$$\frac{l_f}{l_0} = \left(\frac{d_0}{d_f}\right)^2 = \frac{15^2}{1.00^2} = 225$$

Letting l_0 be unity, the longitudinal engineering strain is $e_l = (225 - 1)/1 = 224$. The diametrical engineering strain is calculated as

$$e_d = \frac{1 - 15}{15} = -0.933$$

The longitudinal true strain is given by Eq. (2.9) on p. 36 as

$$= \ln \frac{l}{l_0} = \ln(224) = 5.412$$

The diametrical true strain is

$$e_d = \ln \frac{1}{15} = -2.708$$

Note that this is not equal to the sum of the engineering strains for the individual steps. The following Matlab code can be used to

demonstrate that this is generally true, and not just a conclusion for the specific deformations stated in the problem.

Note the large difference between the engineering and true strains, even though both describe the same phenomenon. Note also that the sum of the true strains (recognizing that the radial strain is $\epsilon_r = \ln \frac{0.5}{15} = -2.708$) in the three principal directions is zero, indicating volume constancy in plastic deformation.

The following Matlab code is useful:

d=0.001;
d0=0.015;
l0=1;

lf=(d0/d)^2*10;
e1=(lf-l0)/l0;
ed=(d-d0)/d0;
epsilon=log(lf/l0);
epsilon_d=log(d/d0);

2.51 A material has the following properties: $S_{ut} = 350$ MPa and $n = 0.20$. Calculate its strength coefficient, K .

Note from Eq. (2.11) on p. 36 that $S_{ut,true} = K \epsilon^n = K n^n$ because at necking $\epsilon = n$. From Fig. 2.3, $S_{ut} = \frac{P}{A_0}$, where P is the load at necking. The true ultimate tensile strength would be

$$S_{ut,true} = P/A = S_{ut} \frac{A_0}{A}$$

From Eq. (2.10),

$$\ln \frac{A_0}{A} = 0.20$$

Therefore,

$$\frac{A_0}{A} = \exp(0.2) = 1.2214$$

Substituting into the expression for true ultimate strength,

$$S_{ut,true} = (350 \text{ MPa}) (1.2214) = 427 \text{ MPa.}$$

The strength coefficient, K , can then be found as

$$K = \frac{427}{0.2^{0.2}} = 589 \text{ MPa.}$$

2.52 Based on the information given in Fig. 2.6, calculate the ultimate tensile strength of 304 stainless steel.

From Fig. 2.6 on p. 39, the true stress for 304 stainless steel at necking (where the slope changes; see Fig. 2.7e) is found to be about 900 MPa, while the true strain is about 0.4. We also know that the ratio of the original to necked areas of the specimen is given by

$$\ln \frac{A_0}{A_{neck}} = 0.40$$

or

$$\frac{A_{neck}}{A_0} = e^{-0.40} = 0.670$$

Thus,

$$S_{ut} = (900)(0.670) = 603 \text{ MPa.}$$

2.53 Calculate the ultimate tensile strength (engineering) of a material whose strength coefficient is 300 MPa and that necks at a true strain of 0.25.

and

$$A_{neck} = A_0 e^{-0.25} = 0.779 A_0$$

Consequently,

$$S_{ut} = (212)(0.779) = 165 \text{ MPa.}$$

2.54 A material has a strength coefficient $K = 700$ MPa. Assuming that a tensile-test specimen made from this material begins to neck at a true strain of 0.20, show that the ultimate tensile strength of this material is 415 MPa.

The approach is the same as in Example 2.1 on p. 41. Since the necking strain corresponds to the maximum load and the necking strain for this material is given as $\epsilon = n = 0.20$, we have, as the true ultimate tensile strength:

$$S_{ut,true} = (700)(0.20)^{0.20} = 507 \text{ MPa.}$$

The cross-sectional area at the onset of necking is obtained from

$$\ln \frac{A_0}{A_{neck}} = n = 0.20.$$

Consequently,

$$A_{neck} = A_0 \exp(-0.20)$$

and the maximum load, P , is

$$\begin{aligned} P &= \sigma A = S_{ut,true} A_0 \exp(-0.20) \\ &= (507)(0.8187)(A_0) = 415 \times 10^6 A_0 \end{aligned}$$

Since $S_{ut} = P/A_0$, we have $S_{ut} = 415$ MPa. This is confirmed with the following Matlab code.

```
K=700e6; n=0.2;
Sut_true=K*n^n;
P=Sut_true*exp(-n)
```

2.55 A cable is made of four parallel strands of different materials, all behaving according to the equation $\sigma = K \epsilon^n$,

where $n = 0.20$. The materials, strength coefficients and cross-sections are as follows:

Material A: $K = 450$ MPa, $A_0 = 7 \text{ mm}^2$;

Material B: $K = 600$ MPa, $A_0 = 2.5 \text{ mm}^2$;

Material C: $K = 300$ MPa, $A_0 = 3 \text{ mm}^2$;

In this problem, $K = 300$ MPa and $n = 0.25$. Following the same procedure as in Example 2.1 on p. 41, the true ultimate tensile strength is

$$\sigma = (300)(0.25)^{0.25} = 212 \text{ MPa}$$

Material D: $K = 750 \text{ MPa}$, $A_0 = 2 \text{ mm}^2$;

- (a) Calculate the maximum tensile force that this cable can withstand prior to necking.
- (b) Explain how you would arrive at an answer if the n values of the three strands were different from each other.

- (a) Necking will occur when $n = 0.20$. At this point the true stresses in each cable are, from Eq. (2.11) on p. 36,

$$\sigma_A = (450)0.2^{0.2} = 326 \text{ MPa}$$

$$\sigma_B = (600)0.2^{0.2} = 435 \text{ MPa}$$

$$\sigma_C = (300)0.2^{0.2} = 217 \text{ MPa}$$

$$\sigma_D = (760)0.2^{0.2} = 543 \text{ MPa}$$

The areas at necking are calculated from $A_{\text{neck}} =$

$A_0 e^{-n}$ (see Example 2.1 on p. 41):

$$A_A = (7)e^{-0.2} = 5.73 \text{ mm}^2$$

$$A_B = (2.5)e^{-0.2} = 2.04 \text{ mm}^2$$

$$A_C = (3)e^{-0.2} = 2.46 \text{ mm}^2$$

$$A_D = (2)e^{-0.2} = 1.64 \text{ mm}^2$$

Hence the total load that the cable can support is

$$\begin{aligned} P &= (326)(5.73) + (435)(2.04) \\ &\quad + (217)(2.46) + (543)(1.64) \\ &= 4180 \text{ N.} \end{aligned}$$

The following Matlab code is helpful:

```
K_A=450e6;
K_B=600e6;
K_C=300e6;
K_D=750e6;
A0_A=7/1e6;
A0_B=2.5/1e6;
A0_C=3/1e6;
A0_D=2/1e6;
n=0.20;
s_A=K_A*n^n;
s_B=K_B*n^n;
s_C=K_C*n^n;
s_D=K_D*n^n;
A_A=A0_A*exp(-1*n);
A_B=A0_B*exp(-1*n);
A_C=A0_C*exp(-1*n);
A_D=A0_D*exp(-1*n);
P=s_A*A_A+s_B*A_B+s_C*A_C+s_D*A_D;
```

- (b) If the n values of the four strands were different, the procedure would consist of plotting the load-elongation curves of the four strands on the same chart, then obtaining graphically the maximum load. Alternately, a computer program can be written to determine the maximum load.

2.56 Using only Fig. 2.6, calculate the maximum load in tension testing of a 304 stainless-steel specimen with an original diameter of 6.0 mm.

Observe from Fig. 2.6 on p. 39 that necking begins at a true strain of about 0.4 for 304 stainless steel, and that $S_{\text{ut,true}}$ is about 900 MPa (this is the location of

the 'kink' in the stress-strain curve). The original cross-sectional area is $A_0 = \pi(0.006 \text{ m})^2/4 = 2.827 \times 10^{-5} \text{ m}^2$. Since $n = 0.4$, a procedure similar to Example 2.1 on p. 41 demonstrates that

$$\frac{A_0}{A_{\text{neck}}} = \exp(0.4) = 1.49$$

Thus

$$S_{\text{ut}} = \frac{900}{1.49} = 604 \text{ MPa}$$

Hence the maximum load is

$$P = (S_{\text{ut}})(A_0) = (604)(2.827 \times 10^{-5})$$

or $P = 17.1 \text{ kN}$. The following Matlab code is helpful to investigate other parameters.

```
n=0.4;
Sut_true=900e6;
A_0=pi*d0*d0/4;
Sut=Sut_true/exp(n);
P=Sut*A_0;
```

2.57 Using the data given in the inside front cover, calculate the values of the shear modulus G for the metals listed in the table.

The important equation is Eq. (2.24) which gives the shear modulus as

$$G = \frac{E}{2(1 + \nu)}$$

The following values can be calculated (mid-range values of ν are taken as appropriate):

Material	E (GPa)	ν	G (GPa)
Al & alloys	69-79	0.32	26-30
Cu & alloys	105-150	0.34	39-56
Pb & alloys	14	0.43	4.9
Mg & alloys	41-45	0.32	15.5-17.0
Mo & alloys	330-360	0.32	125-136
Ni & alloys	180-214	0.31	69-82
Steels	190-200	0.30	73-77
Stainless steels	190-200	0.29	74-77
Ti & alloys	80-130	0.32	30-49
W & alloys	350-400	0.27	138-157
Ceramics	70-1000	0.2	29-417
Glass	70-80	0.24	28-32
Rubbers	0.01-0.1	0.5	0.0033-0.033
Thermoplastics	1.4-3.4	0.36	0.51-1.25
Thermosets	3.5-17	0.34	1.3-6.34

2.58 Derive an expression for the toughness of a material represented by the equation $\sigma = K(\epsilon + 0.2)^n$ and whose fracture strain is denoted as ϵ_f .

Recall that toughness is the area under the stress-strain curve, hence the toughness for this material would be

given by

$$\begin{aligned} \text{Toughness} &= \int_0^{\sigma_f} \sigma \, d\epsilon \\ &= \int_0^{\sigma_f} K (\epsilon + 0.2)^n \, d\epsilon \\ &= \frac{K}{n+1} (\sigma_f + 0.2)^{n+1} - 0.2^{n+1} K \end{aligned}$$

2.59 A cylindrical specimen made of a brittle material 50 mm high and with a diameter of 25 mm is subjected to a compressive force along its axis. It is found that fracture takes place at an angle of 45° under a load of 130 kN. Calculate the shear stress and the normal stress, respectively, acting on the fracture surface.

Assuming that compression takes place without friction, note that two of the principal stresses will be zero. The third principal stress acting on this specimen is normal to the specimen and its magnitude is

$$\sigma_3 = -\frac{130,000}{(\pi/4)(0.025)^2} = -264 \text{ MPa}$$

The Mohr's circle for this situation is shown below.

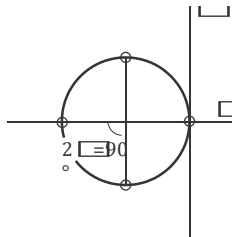

The fracture plane is oriented at an angle of 45°, corresponding to a rotation of 90° on the Mohr's circle. This corresponds to a stress state on the fracture plane of $-\sigma = \tau = 264/2 = 132 \text{ MPa}$.

2.60 What is the modulus of resilience of a highly cold-worked piece of steel with a hardness of 280 HB? Of

a piece of highly cold-worked copper with a hardness of 175 HB?

Referring to Fig. 2.22 on p. 57, the value of c in Eq. (2.31) is approximately 3.2 for highly cold-worked steels and around 3.4 for cold-worked aluminum. Therefore, approximate $c = 3.3$ for cold-worked copper. From Eq. (2.31),

$$S_{y,\text{steel}} = \frac{H}{3.2} = \frac{280}{3.2} = 87.5 \text{ kg/mm}^2 = 858 \text{ MPa}$$

$$S_{y,\text{Cu}} = \frac{H}{3.3} = \frac{175}{3.3} = 53.0 \text{ kg/mm}^2 = 520 \text{ MPa}$$

From the inside front cover, $E_{\text{steel}} = 200 \text{ GPa}$ and $E_{\text{Cu}} = 124 \text{ GPa}$. The modulus of resilience is calculated from Eq. (2.5) on p. 34. For steel: 12

or a modulus of resilience for steel of $1.81 \text{ MN}\cdot\text{m/m}^3$. For copper,

$$\text{Modulus of Resilience} = \frac{S_y^2}{2E} = \frac{520^2 \times 10^6}{2(124 \times 10^9)}$$

or a modulus of resilience for copper of $1.09 \text{ MN}\cdot\text{m/m}^3$.

Note that these values are slightly different than the values given in the text. This is due to the fact that (a) highly cold-worked metals such as these have a much higher yield stress than the annealed materials described in the text; and (b) arbitrary property values are given in the statement of the problem.

2.61 Calculate the work done in frictionless compression of a solid cylinder 40 mm high and 15 mm in diameter to a reduction in height of 50% for the following materials: (a) 1100-O aluminum; (b) annealed copper; (c) annealed 304 stainless steel; and (d) 70-30 brass, annealed.

The work done is calculated from Eq. (2.59) where the specific energy, u , is obtained from Eq. (2.57) on p. 73. Since the reduction in height is 50%, the final height is 20 mm and the absolute value of the true strain is

$$= \ln \frac{40}{20} = 0.6931$$

K and n are obtained from Table 2.3 as follows:

Material	K (MPa)	n
1100-O Al	180	0.20
Cu, annealed	315	0.54
304 Stainless, annealed	1300	0.30
70-30 brass, annealed	895	0.49

u is then calculated from Eq. (2.57). For example, for 1100-O aluminum, where K is 180 MPa and n is 0.20, u is calculated as

$$u = \frac{K}{n+1} \epsilon^{n+1} = \frac{(180)(0.6931)^{1.2}}{1.2} = 96.6 \text{ MN/m}^3$$

The volume is calculated as

$$V = \pi r^2 l = \pi(0.0075)^2(0.04) = 7.069 \times 10^{-6} \text{ m}^3$$

The work done is the product of the specific work, u , and the volume, V . Therefore, the results can be tabulated as follows.

Material	u (MN/m ³)	Work (Nm)
1100-O Al	96.6	682
late		
304 Stainless, annealed	620	4389
70-30 brass, annealed	348	2460

Cu, annealed

168

1186

$$\text{Modulus of Resilience} = \frac{S_y^2}{2E} = \frac{858 \times 10^6 \text{ }^2}{2(200 \times 10^9)}$$

The following Matlab code can be used to confirm results:

```

h0=0.040;
d0=0.015;
hf=0.020;
epsilon=log(h0/hf);
K=180e6;
n=0.20;
u=K*epsilon^(n+1)/(n+1);

```

```

V=pi*d0^2/4*h0;
Work=u*V;

```

2.62 A tensile-test specimen is made of a material repre-

sented by the equation $\sigma = K(\epsilon + n)^n$. (a) Determine the true strain at which necking will begin. (b) Show that it is possible for an engineering material to exhibit this behavior.

- (a) In Section 2.2.4 on p. 40, it was noted that instability, hence necking, requires the following condition to be fulfilled:

$$\frac{d\sigma}{d\epsilon} = \sigma$$

Consequently, for this material we have

$$Kn(\epsilon + n)^{n-1} = K(\epsilon + n)^n$$

This is solved as $n = 0$; thus necking begins as soon as the specimen is subjected to tension.

- (b) Yes, this behavior is possible. Consider a tension-test specimen that has been strained to necking and then unloaded. Upon loading it again in tension, it will immediately begin to neck.

2.63 Take two solid cylindrical specimens of equal diameter, but different heights. Assume that both specimens

are compressed (frictionless) by the same percent reduction, say 50%. Prove that the final diameters will be

the same.

Identify the shorter cylindrical specimen with the sub-

script s and the taller one as t , and their original diameter as D . Subscripts f and o indicate final and original, respectively. Because both specimens undergo the same percent reduction in height,

$$\frac{h_{tf}}{h_{to}} = \frac{h_{sf}}{h_{so}}$$

and from volume constancy,

$$\frac{D_o^2}{D_f^2} = \frac{h_o}{h_f}$$

and

2.64 In a disk test performed on a specimen 50 mm in diameter and 2.5 mm thick, the specimen fractures at a stress of 500 MPa. What was the load on it at fracture?

Equation (2.22) is used to solve this problem. Noting that $\sigma = 500$ MPa, $d = 50$ mm = 0.05 m, and $t = 2.5$ mm = 0.0025 m, we can write

$$\sigma = \frac{2P}{\pi dt} \rightarrow P = \frac{\sigma \pi dt}{2}$$

Therefore

$$P = \frac{(500 \times 10^6) \pi (0.05)(0.0025)}{2} = 98 \text{ kN.}$$

The following Matlab code allows for variation in parameters for this problem.

```

d=0.050;
t=0.0025;
sigma=500e6;
P=sigma*pi*d*t/2;

```

2.65 In Fig. 2.29a, let the tensile and compressive residual stresses both be 70 MPa, and the modulus of elasticity of the material be 200 GPa with a modulus of resilience of 225 kN-m/m³. If the original length in diagram (a) is 500 mm, what should be the stretched length in diagram (b) so that, when unloaded, the strip will be free of residual stresses?

Note that the yield stress can be obtained from Eq. (2.5) on p. 34 as

$$\text{Mod. of Resilience} = MR = \frac{S_y^2}{2E}$$

Thus,

$$S_y = \sqrt{2(MR)E} = \sqrt{2(225 \times 10^3)(200 \times 10^9)}$$

or $S_y = 300$ MPa. The strain required to relieve the residual stress is:

$$\frac{\sigma_c}{E} + \frac{S_y}{E} = \frac{70 \times 10^6}{200 \times 10^9} + \frac{300 \times 10^6}{200 \times 10^9} = 0.00185$$

Therefore,

$$= \ln \frac{l_f}{l_o} = \ln \frac{l_f}{0.500 \text{ m}} = 0.00185$$

Therefore, $l_f = 0.50093$ m. The following Matlab code is helpful

```

l_tf =

```

h_{to}

$\frac{h_{sf}}{h_{so}}$

$$\begin{aligned}
& \frac{D_s}{t_i} \\
& = \frac{g}{D_m} \\
& \quad a \\
& \quad - \\
& \quad c \\
& = \\
& \frac{D_7}{so} \\
& = \frac{0}{2} \\
& \quad e \\
& \quad D \\
& \quad s \\
& \quad t \\
& \quad E \\
& = \\
& \quad 2 \\
& \quad 0 \\
& \quad 0 \\
& \quad e \\
& \quad 9 \\
& \quad ; \\
& \quad M \\
& \quad R \\
& = \\
& \quad 2 \\
& \quad 2 \\
& \quad 5 \\
& \quad e \\
& \quad 3 \\
& \quad ; \\
& \quad 1 \\
& \quad 0 \\
& = \\
& \quad 0 \\
& \quad \cdot \\
& \quad 5 \\
& \quad ; \\
& \quad Sy=(2*MR \\
& \quad *E)^{(0. \\
& \quad 5)}; \\
& \quad \epsilon = \\
& \quad \frac{\sigma_c}{E+Sy/E};
\end{aligned}$$

Because $D_{to} = D_{so}$, note from these relationships that $D_{tf} = D_{sf}$.

$If=10*\exp(\epsilon);$

2.66 A horizontal rigid bar *c-c* is subjecting specimen *a* to tension and specimen *b* to frictionless compression such that the bar remains horizontal. (See the accompanying figure.) The force *F* is located at a distance ratio of 2:1. Both specimens have an original cross-sectional area of 0.0001 m² and the original lengths are *a* = 200 mm and *b* = 115 mm. The material for specimen *a* has a true-stress-true-strain curve of $\sigma = (700 \text{ MPa})^{0.5}$. Plot the true-stress-true-strain curve that the material for specimen *b* should have for the bar to remain horizontal.

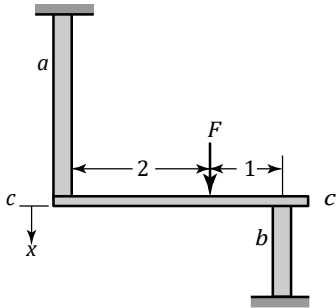

From the equilibrium of vertical forces and to keep the bar horizontal, we note that $2F_a = F_b$. Hence, in terms of true stresses and instantaneous areas, we have

$$2\sigma_a A_a = \sigma_b A_b$$

From volume constancy we also have, in terms of original and final dimensions

$$A_{oa} L_{oa} = A_a L_a$$

and

$$A_{ob} L_{ob} = A_b L_b$$

where $L_{oa} = (0.200/0.115)L_{ob} = 1.73L_{ob}$. From these relationships we can show that

$$\sigma_b = 2 \frac{0.2}{0.115} K \sigma_a \frac{L_b}{L_a}$$

Since $\sigma_a = K \epsilon_a^{0.5}$ where $K = 700 \text{ MPa}$, we can now write

$$\sigma_b = \frac{0.4K}{0.115} \frac{L_b}{L_a} \sqrt{\epsilon_a}$$

Hence, for a deflection of *x*,

$$\sigma_b = \frac{0.4K}{0.115} \frac{0.115 - x}{0.2 + x} \ln \frac{0.2 + x}{0.2}$$

The true strain in specimen *b* is given by

$$\epsilon_b = \ln \frac{0.115 - x}{0.115}$$

must approach zero. This observation suggests that specimen *b* cannot have a true stress-true strain curve typical of metals, and that it will have a maximum at some strain. This is seen in the plot of σ_b shown below.

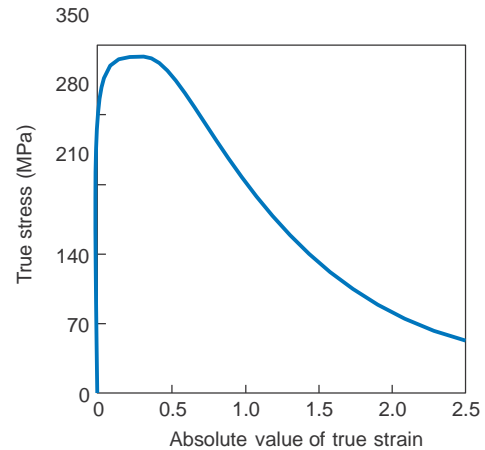

2.67 Inspect the curve that you obtained in Problem 2.66. Does a typical strain-hardening material behave in that manner? Explain.

Based on the discussions in Section 2.2.3, it is obvious that ordinary metals would not normally behave in this manner. However, under certain conditions, the following could explain such behavior:

- When specimen *b* is heated to higher and higher temperatures as deformation progresses, with its strength decreasing as *x* is increased further after the maximum value of stress.
- In compression testing of brittle materials, such as ceramics, when the specimen begins to fracture.
- If the material is susceptible to thermal softening, then it can display such behavior with a sufficiently high strain rate.

2.68 Show that you can take a bent bar made of an elastic, perfectly plastic material and straighten it by stretching it into the plastic range. (Hint: Observe the events shown in Fig. 2.29.)

The series of events that takes place in straightening a bent bar by stretching it can be visualized by starting with a stress distribution as in Fig. 2.29a on p. 64, which would represent the unbending of a bent section.

As we apply tension, we algebraically add a uniform tensile stress to this stress distribution. Note that the change in the stresses is the same as that depicted in Fig. 2.29d, namely, the tensile stress increases and reaches the yield stress, S_y . The compressive stress

reaches the yield stress, S_y . The compressive stress

By inspecting the figure in the problem statement, we note that while specimen a gets longer, it will continue exerting some force F_a . However, specimen b will eventually acquire a cross-sectional area that will become infinite as x approaches 115 mm, thus its strength

is first reduced in magnitude, then becomes tensile. Eventually, the whole cross section reaches the constant yield stress, S_y . Because we now have a uniform stress distribution throughout its thickness, the bar becomes straight and remains straight upon unloading.

2.69 A bar 1 m long is bent and then stress relieved. The radius of curvature to the neutral axis is 0.50 m. The bar is 25 mm thick and is made of an elastic, perfectly plastic material with $S_y = 500$ MPa and $E = 207$ GPa. Calculate the length to which this bar should be stretched so that, after unloading, it will become and remain straight.

A review of bending theory from a solid mechanics textbook is necessary for this problem. In particular, it should be recognized that when the curved bar becomes straight, the engineering strain it undergoes is given by the expression

$$e = \frac{t}{2\rho}$$

where t is the thickness and ρ is the radius to the neutral axis. Hence in this case,

$$e = \frac{(0.025)}{2(0.50)} = 0.025$$

Since $S_y = 500$ MPa and $E = 207$ GPa, we find that the elastic limit for this material is at an elastic strain of

$$e = \frac{S_y}{E} = \frac{500 \text{ MPa}}{207 \text{ GPa}} = 0.00242$$

which is smaller than 0.025. Therefore, we know that the bar must be loaded in the plastic range. Following the description in Answer 2.68 above, the strain required to straighten the bar is twice the elastic limit, or

$$e = (2)(0.00242) = 0.0048$$

or

$$\frac{l_f - l_0}{l_0} = 0.0048 \quad \rightarrow \quad l_f = 0.005l_0 + l_0$$

or $l_f = 1.0049$ m.

The following Matlab code is helpful.

```
l=1;
rho=0.5;
Sy=500e6;
E=207e9;
t=0.025;
epsilon=t/2/rho;
epsilon_y=Sy/E;
epsilon_b=2*epsilon_y;
lf=1/(1-epsilon_b);
```

2.70 Assume that a material with a uniaxial yield strength S_y yields under a stress state of principal stresses $\sigma_1, \sigma_2, \sigma_3$, where $\sigma_1 > \sigma_2 > \sigma_3$. Show that the superpo-

the maximum shear stress criterion as well. Equation (2.39) on p. 67 gives

$$(\sigma_1 - \sigma_2)^2 + (\sigma_2 - \sigma_3)^2 + (\sigma_3 - \sigma_1)^2 = 2S_y^2$$

Now consider a new stress state where the principal stresses are

$$\begin{aligned} \sigma_1^0 &= \sigma_1 + p \\ \sigma_2^0 &= \sigma_2 + p \\ \sigma_3^0 &= \sigma_3 + p \end{aligned}$$

which represents a new loading with an additional hydrostatic pressure, p . The distortion-energy criterion for this stress state is

$$(\sigma_1^0 - \sigma_2^0)^2 + (\sigma_2^0 - \sigma_3^0)^2 + (\sigma_3^0 - \sigma_1^0)^2 = 2S_y^2$$

or

$$\begin{aligned} 2S_y^2 &= [(\sigma_1 + p) - (\sigma_2 + p)]^2 \\ &+ [(\sigma_2 + p) - (\sigma_3 + p)]^2 \\ &+ [(\sigma_3 + p) - (\sigma_1 + p)]^2 \end{aligned}$$

which can be simplified as

$$(\sigma_1 - \sigma_2)^2 + (\sigma_2 - \sigma_3)^2 + (\sigma_3 - \sigma_1)^2 = 2S_y^2$$

which is the original yield criterion. Hence, the yield criterion is unaffected by the superposition of a hydrostatic pressure.

2.71 Give two different and specific examples in which the maximum-shear-stress and the distortion-energy criteria give the same answer.

In order to obtain the same answer for the two yield

criteria, we refer to Fig. 2.32 on p. 70 for plane stress and note the coordinates at which the two diagrams meet. Examples are: simple tension, simple compres-

sion of a hydrostatic stress p on this system (such as placing the specimen in a chamber pressurized with a liquid) does not affect yielding. In other words, the material will still yield according to yield criteria.

This solution considers the distortion-energy criterion, although the same derivation could be performed with

sion, equal biaxial tension, and equal biaxial compression. Thus, acceptable answers would include (a) wire rope, as used on a crane to lift loads; (b) spherical pressure vessels, including balloons and gas storage tanks; and (c) shrink fits.

2.72 A thin-walled spherical shell with a yield strength S_y is subjected to an internal pressure p . With appropriate equations, show whether or not the pressure required to yield this shell depends on the particular yield criterion used.

Here we have a state of plane stress with equal biaxial tension. The answer to Problem 2.71 leads one to immediately conclude that both the maximum shear stress and distortion energy criteria will give the same results. We will now demonstrate this more rigorously. The principal membrane stresses are given by

$$\sigma_1 = \sigma_2 = \frac{pr}{2t}$$

and

$$\sigma_3 = 0$$

Using the maximum shear-stress criterion, we find that

$$\sigma_1 - 0 = S_y.$$

Hence

$$p = \frac{2tS_y}{r}$$

Using the distortion-energy criterion, we have

$$(0 - 0)^2 + (\sigma_2 - 0)^2 + (0 - \sigma_1)^2 = 2S_y^2$$

Since $\sigma_1 = \sigma_2$, then this gives $\sigma_1 = \sigma_2 = S_y$, and the same expression is obtained for pressure.

2.73 Show that, according to the distortion-energy criterion, the yield strength in plane strain is $1.15S_y$, where S_y is the uniaxial yield strength of the material.

A plane-strain condition is shown in Fig. 2.35d, where σ_1 is the yield stress of the material in plane strain (S_y^0), σ_3 is zero, and $\sigma_2 = 0$. From Eq. 2.43b, we find

that $\sigma_2 = \sigma_1/2$. Substituting these into the distortion-energy criterion given by Eq. (2.37),

$$\sigma_1 - \frac{\sigma_1}{2}^2 + \frac{\sigma_1}{2} - 0^2 + (0 - \sigma_1)^2 = 2S_y^2$$

and

$$\frac{3\sigma_1^2}{2} = 2S_y^2$$

hence

$$\sigma_1 = \sqrt{\frac{2}{3}}S_y \approx 1.15S_y$$

2.74 What would be the answer to Problem 2.73 if the maximum shear stress criterion were used?

Because σ_2 is an intermediate stress and using Eq. (2.38) on p. 67, the answer would be

$$\sigma_1 - 0 = S_y.$$

Hence, the yield stress in plane strain will be equal to the uniaxial yield stress, S_y .

2.75 A closed-end, thin-walled cylinder of original length l , thickness t , and internal radius r is subjected to an internal pressure p . Using the generalized Hooke's law equations, show the change, if any, that occurs in the length of this cylinder when it is pressurized. Let $\nu = 0.25$.

A closed-end, thin-walled cylinder under internal pressure is subjected to the following principal stresses:

$$\sigma_1 = \frac{pr}{2t}; \quad \sigma_2 = \frac{pr}{t}; \quad \sigma_3 = 0$$

where the subscript 1 is the longitudinal direction, 2 is the hoop direction, and 3 is the thickness direction. From Hooke's law given by Eq. (2.34) on p. 66,

$$\begin{aligned} \epsilon_1 &= \frac{1}{E} [\sigma_1 - \nu(\sigma_2 + \sigma_3)] \\ &= \frac{1}{E} \left[\frac{pr}{2t} - \nu \left(\frac{pr}{t} + 0 \right) \right] \end{aligned}$$

Since all the quantities are positive (note that in order to produce a tensile membrane stress, the pressure is positive as well), the longitudinal strain is finite and positive. Thus the cylinder becomes longer when pressurized, as it can also be deduced intuitively.

2.76 A round, thin-walled tube is subjected to tension in the elastic range. Show that both the thickness and the diameter decrease as tension increases.

The stress state in this case is $\sigma_1, \sigma_2 = \sigma_3 = 0$. From the generalized Hooke's law equations given by Eq. (2.34), and denoting the axial direction as 1, the hoop direction as 2, and the radial direction as 3, we have for the hoop strain:

$$\epsilon_2 = \frac{1}{E} [\sigma_2 - \nu(\sigma_1 + \sigma_3)] = -\frac{\nu\sigma_1}{E}$$

Therefore, the diameter is negative for a tensile (positive) value of σ_1 . For the radial strain, the generalized Hooke's law gives

$$\epsilon_3 = \frac{1}{E} [\sigma_3 - \nu(\sigma_1 + \sigma_2)] = -\frac{\nu\sigma_1}{E}$$

Therefore, the radial strain is also negative and the wall becomes thinner for a positive value of σ_1 .

2.77 Take a long cylindrical balloon and, with a thin felt-tip pen, mark a small square on it. What will be the shape of this square after you blow up the balloon, (a) a larger square; (b) a rectangle with its long axis in the circumferential direction; (c) a rectangle with its long axis in the longitudinal direction; or (d) an ellipse? Perform this experiment, and, based on your observations, explain the results, using appropriate equations. Assume that the material the balloon is made up of is perfectly elastic and isotropic and that this situation represents a thin-walled closed-end cylinder under internal pressure.

This is a simple graphic way of illustrating the generalized Hooke's law equations. A balloon is a readily available and economical method of demonstrating these stress states. It is also encouraged to assign the students the task of predicting the shape numerically; an example of a valuable experiment involves partially inflating the balloon, drawing the square, then expanding it further and having the students predict the dimensions of the square.

Although not as readily available, a rubber tube can be used to demonstrate the effects of torsion in a similar manner.

2.78 Take a cubic piece of metal with a side length l_0 and deform it plastically to the shape of a rectangular parallelepiped of dimensions l_1, l_2 , and l_3 . Assuming that the material is rigid and perfectly plastic, show that

$$= \frac{E}{6t} (2t^2 + 3t)$$

volume constancy requires that the following expression be satisfied: $v_1 + v_2 + v_3 = 0$.

The initial volume and the final volume are constant, so that

$$l_o l_o l_o = l_1 l_2 l_3 \rightarrow \frac{l_1 l_2 l_3}{l_o l_o l_o} = 1$$

Taking the natural log of both sides,

$$\ln \frac{l_1 l_2 l_3}{l_o l_o l_o} = \ln(1) = 0$$

$$l_o l_o l_o$$

since $\ln(AB) = \ln(A) + \ln(B)$,

$$\ln \frac{l_1}{l_o} + \ln \frac{l_2}{l_o} + \ln \frac{l_3}{l_o} = 0$$

From the definition of true strain given by Eq. (2.9) on

p. 36, $\ln \frac{l_1}{l_o} = \epsilon_1$, etc., so that

$$\epsilon_1 + \epsilon_2 + \epsilon_3 = 0.$$

According to the distortion-energy criterion and referring to Eq. (2.53) on p. 72 for effective stress, we find that

$$\begin{aligned} \bar{\sigma} &= \sqrt{\frac{1}{2} \left(\sigma_1 - \frac{\sigma_1}{2} \right)^2 + \frac{\sigma_1}{2}^2 + (\sigma_1)^2}^{1/2} \\ &= \sqrt{\frac{1}{2} \left(\frac{1}{2} \right)^2 + \frac{1}{2} + 1} \sigma_1 \\ &= \sqrt{\frac{1}{2} \left(\frac{1}{4} + 1 \right) + 1} \sigma_1 \\ &= \sqrt{\frac{1}{2} \left(\frac{5}{4} \right) + 1} \sigma_1 = \frac{\sqrt{13}}{2} \sigma_1 \end{aligned}$$

Note that for this case $\epsilon_3 = 0$. Since volume constancy is maintained during plastic deformation, we also have $\epsilon_3 = -\epsilon_1$. Substituting these into Eq. (2.54), the effective strain is found to be

$$\bar{\epsilon} = \frac{2}{\sqrt{3}} \epsilon_1$$

2.79 What is the diameter of an originally 40-mm-diameter solid steel ball when the ball is subjected to a hydrostatic pressure of 2 GPa?

From Eq. (2.47) on p. 71, and noting that, for this case, all three strains are equal and all three stresses are equal to $-p$ (accounting for the fact that a positive pressure is equivalent to a negative stress),

$$\epsilon_3 = \frac{1-2\nu}{E} (-3p)$$

where p is the hydrostatic pressure. Thus, from the inside front cover, $\nu = 0.3$ and $E = 200$ GPa, so that

$$\epsilon_3 = \frac{1-2\nu}{E} (-p) = \frac{1-0.6}{200} (-2) \quad (-2)$$

or $\epsilon_3 = -0.004$. Therefore

$$\ln \frac{D_f}{D_o} = -0.004$$

Solving for D_f ,

$$D_f = D_o e^{-0.004} = (40) e^{-0.004} = 39.84 \text{ mm.}$$

The following Matlab code is useful.

```
nu=0.3;
E=200e9;
```

2.81 (a) Calculate the work done in expanding a 2-mm-thick spherical shell from a diameter of 100 mm to 150 mm, where the shell is made of a material for which $\sigma = 200 + 50 \epsilon^{0.5}$ MPa. (b) Does your answer depend on the particular yield criterion used? Explain.

(a) For this case, the membrane stresses are given by

$$\sigma_1 = \sigma_2 = \frac{pt}{2t}$$

and the strains are

$$\epsilon_1 = \epsilon_2 = \ln \frac{r_f}{r_o}$$

Note that we have a balanced (or equal) biaxial state of plane stress. Thus, the specific energy (for a perfectly-plastic material) will, according to either yield criteria, be

$$u = 2\sigma_1 \epsilon_1 = 2S_y \ln \frac{r_f}{r_o}$$

The work done will be, according to Eq. (2.59) on p. 73,

$$\begin{aligned} W &= (\text{Volume})(u) \\ &= 4\pi r_o^2 t_o \cdot 2S_y \ln \frac{r_f}{r_o} \\ &= 8\pi S_y r_o^2 t_o \ln \frac{r_f}{r_o} \end{aligned}$$

$d_o = 0.040$;
 $p = 2e9$;
 $\epsilon = -(1 - 2\nu)/E * p$;
 $df = d_o * \exp(\epsilon)$;

2.80 Determine the effective stress and effective strain in plane-strain compression according to the distortion-energy criterion.

Referring to Fig. 2.31d, note that, for this case, $\sigma_3 = 0$ and $\sigma_2 = \sigma_1/2$, as can be seen from Eq. (2.45) on p. 70.

$$\sigma_1 = \sigma_0 \ln \frac{r_o}{r}$$

Using the pressure-volume method of work, we begin with the formula

$$W = \int p dV$$

where V is the volume of the sphere. We integrate this equation between the limits V_o and V_f , noting that

$$p = \frac{2tS_y}{r}$$

and

$$V = \frac{4\pi r^3}{3}$$

so that

$$dV = 4\pi r^2 dr$$

Also, from volume constancy, we have

$$t = \frac{r_o^2 t_o}{r^2}$$

Combining these expressions, we obtain

$$W = 8\pi S_y r_o^2 t_o \int_{r_o}^{r_f} \frac{dr}{r} = 8\pi S_y r_o^2 t_o \ln \frac{r_f}{r_o}$$

which is the same expression obtained earlier. To obtain a numerical answer to this problem, note that S_y should be replaced with an average value \bar{S}_y . Also note that $\ln \frac{r_f}{r_o} = \ln(150/100) = 0.4055$. Thus,

$$\bar{S}_y = 200 + \frac{50(0.4055)^{1.5}}{1.5} = 208.6 \text{ MPa}$$

Hence the work done is

$$\begin{aligned} W &= 8\pi \bar{S}_y r_o^2 t_o \ln \frac{r_f}{r_o} \\ &= 8\pi (208.6 \times 10^6)(0.1)^2(0.001) \ln(75/50) \\ &= 21.26 \text{ kN-m} \end{aligned}$$

(b) The yield criterion used does not matter because

this is equal biaxial tension; see the answer to Problem 2.71.

2.82 A cylindrical slug that has a diameter of 25 mm and is 25 mm high is placed at the center of a 50-mm-diameter cavity in a rigid die (see the accompanying figure). The slug is surrounded by a compressible matrix, the pressure of which is given by the relation

$$p_m = 150 \frac{\Delta V}{V_{om}} \text{ MPa}$$

where m denotes matrix and V_{om} is the original volume of the compressible matrix. Both the slug and the matrix are being compressed by a piston and without any friction. The initial pressure of the matrix is zero, and the slug material has the true-stress-true-strain curve of $\sigma = 600 \epsilon^{0.4}$.

F

Obtain an expression for the force F versus piston travel d up to $d = 10$ mm.

The total force, F , on the piston will be

$$F = F_w + F_m,$$

where the subscript w denotes the workpiece and m the matrix. As d increases, the matrix pressure increases, thus subjecting the slug to transverse compressive stresses on its circumference. Hence the slug will be subjected to triaxial compressive stresses, with $\sigma_2 = \sigma_3$. Using the maximum shear-stress criterion for simplicity, we have

$$\sigma_1 = \sigma + \sigma_2$$

where σ_1 is the required compressive stress on the slug, σ is the flow stress of the slug material corresponding to a given strain, and given as $\sigma = 600 \epsilon^{0.4}$, and σ_2 is the compressive stress due to matrix pressure.

The initial volume of the slug is equal to

$$V_s = \frac{\pi}{4} (0.025)^2 (0.025) = 1.227 \times 10^{-5} \text{ m}^3$$

and the volume of the cavity when $d = 0$ is

$$V_{co} = \frac{\pi}{4} (0.050)^2 (0.025) = 4.909 \times 10^{-5}$$

The volume of the matrix at any value of d is then

$$\begin{aligned} V_m &= \frac{\pi}{4} (0.050)^2 (0.025 - d) - 1.227 \times 10^{-5} \\ &= 3.682 \times 10^{-5} - 0.001963d \end{aligned}$$

from which we obtain

$$\begin{aligned} \frac{\Delta V}{V_{om}} &= \frac{V_{om} - V_m}{V_{om}} \\ &= \frac{(3.682 \times 10^{-5}) - (3.682 \times 10^{-5} - 0.001963d)}{3.682 \times 10^{-5}} \\ &= 53.33d \end{aligned}$$

Note that when $d = 0.01875$ m, the volume of the matrix becomes zero. Therefore, the matrix volume is still positive in the bounds defined by the problem ($d < 0.010$). The matrix pressure, hence σ_2 , is now given by

$$\sigma_2 = 150 \frac{\Delta V}{V} = 150(53.33d) = 8000d$$

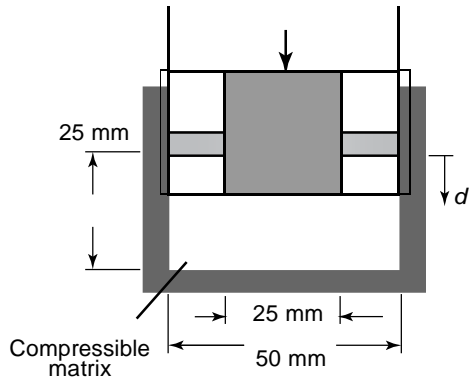

The absolute value of the true strain in the slug is given by

$$= \ln \frac{0.025}{0.025 - d}$$

with which we can determine the value of σ for any d . The cross-sectional area of the workpiece at any d is

$$A_w = \frac{(\pi/4)(0.025)^2(0.025)}{0.025 - d} = \frac{1.227 \times 10^{-5}}{0.025 - d}$$

and that of the matrix is

$$A_m = \frac{\pi}{4} (0.050)^2 - A_w = 1.963 \times 10^{-3} - A_w$$

The required compressive stress on the slug is

$$\sigma_1 = \sigma + \sigma_2 = \sigma + 8000d$$

We may now write the total force on the piston as

$$F = A_w (\sigma + 8000d) + A_m 8000d \text{ MN}$$

The following data gives some numerical results:

d (m)	A_w (m ²)	σ (MPa)	F (kN)
0	4.908×10^{-3}	0	0
0.002	5.335×10^{-3}	0.0834	150
0.004	5.843×10^{-3}	0.174	237
0.006	6.458×10^{-3}	0.274	325
0.008	7.218×10^{-3}	0.386	421
0.010	8.180×10^{-3}	0.511	532

And the following plot shows the desired results.

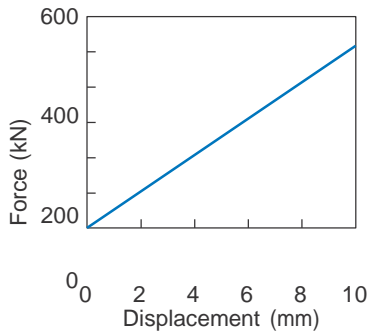

2.83 A specimen in the shape of a cube 25 mm on each side is being compressed without friction in a die cavity, as

shown in Fig. 2.31d, where the width of the groove is 30 mm. Assume that the linearly strain-hardening material has the true-stress-true-strain curve given by

$\sigma = 70 + 30 \epsilon$ MPa. Calculate the compressive force

required when the height of the specimen is 3 mm, according to both yield criteria.

Note that the volume of the specimen is constant and

can be expressed as

$$(0.025)^3 = (h)(x)(x)$$

where x is the lateral dimension assuming the spec-

imen expands uniformly during compression. Since $h = 3$ mm, we have $x = 72.17$ mm. Thus, the specimen touches the walls and hence this becomes a plane-

The cross-sectional area on which the force is acting is

$$\text{Area} = \frac{(0.025)^3}{0.003} = 5.208 \times 10^{-3} \text{ m}^2$$

According to the maximum shear-stress criterion given by Eq. (2.41) on p. 69, we have $\sigma_1 = \sigma_f$ (because $\sigma_3 = 0$), and thus

$$\text{Force} = (133.6)(5.208 \times 10^{-3}) = 696 \text{ kN.}$$

According to the distortion energy criterion in Eq. (2.46) on p. 71, we have $\sigma_1 = 1.15\sigma_f$, or

$$\text{force} = (1.15)(696) = 800 \text{ kN.}$$

2.84 Obtain expressions for the specific energy for a material for each of the stress-strain curves shown in Fig. 2.7, similar to those shown in Section 2.12.

Equation (2.56) on p. 72 gives the specific energy as

$$u = \int_0^{\epsilon} \sigma d\epsilon$$

1. For a perfectly-elastic material as shown in Fig 2.7a, this expression becomes

$$u = \int_0^{\epsilon} E \epsilon d\epsilon = E \frac{\epsilon^2}{2} = \frac{E}{2} \epsilon^2$$

2. For a rigid, perfectly-plastic material as shown in Fig. 2.7b, this is

$$u = \int_0^{\epsilon} S_y d\epsilon = S_y \epsilon = S_y \epsilon$$

3. For an elastic, perfectly plastic material, this is identical to an elastic material for $\epsilon < S_y/E$, and for $\epsilon > S_y/E$ it is

$$\begin{aligned} u &= \int_0^{\epsilon} \sigma d\epsilon = \int_0^{S_y/E} E \epsilon d\epsilon + \int_{S_y/E}^{\epsilon} S_y d\epsilon \\ &= \frac{E}{2} \left(\frac{S_y}{E}\right)^2 + S_y \left(\epsilon - \frac{S_y}{E}\right) \\ &= \frac{S_y^2}{2E} + S_y \epsilon - \frac{S_y^2}{E} = S_y \epsilon - \frac{S_y^2}{2E} \end{aligned}$$

4. For a rigid, linearly strain hardening material, the specific energy is

$$u = \int_0^{\epsilon} (S_y + E \epsilon) d\epsilon = S_y \epsilon + \frac{E}{2} \epsilon^2$$

strain problem (see Fig. 2.31d). The absolute value of the true strain is given by Eq. (2.10) on p. 36 as

$$\frac{\sigma_y - \sigma_p}{\sigma_y} = \frac{70 - 133.6}{70} = -0.91$$

$$= \ln \frac{25}{3} = 2.12$$

We can now determine the flow stress, σ_f , of the material at this strain as

$$\sigma_f = 70 + 30(2.12) = 133.6 \text{ MPa}$$

5. For an elastic, linear strain hardening material, the specific energy is identical to an elastic material for $\epsilon_1 < S_y/E$ and for $\epsilon_1 > S_y/E$ it is

$$u = \int_0^{\epsilon_1} \left(S_y + E_p \left(\epsilon - \frac{S_y}{E} \right) \right) d\epsilon$$

$$= \int_0^{\epsilon_1} S_y d\epsilon - \frac{E_p}{E} \int_0^{\epsilon_1} \left(\epsilon - \frac{S_y}{E} \right) d\epsilon$$

$$= S_y \epsilon_1 - \frac{E_p}{E} \left(\frac{\epsilon_1^2}{2} - \frac{S_y \epsilon_1}{E} \right)$$

2.85 A material with a yield strength of 75 MPa is subjected to principal (normal) stresses of σ_1 , $\sigma_2 = 0$, and $\sigma_3 = -\sigma_1/2$. What is the value of σ_1 when the metal yields according to the von Mises criterion?

The distortion-energy criterion, given by Eq. (2.39) on p. 67, is

$$(\sigma_1 - \sigma_2)^2 + (\sigma_2 - \sigma_3)^2 + (\sigma_3 - \sigma_1)^2 = 2S_y^2$$

Substituting $S_y = 75$ MPa and σ_1 , $\sigma_2 = 0$ and $\sigma_3 = -\sigma_1/2$, we have

$$2(75)^2 = (\sigma_1)^2 + \frac{\sigma_1^2}{2} + \frac{\sigma_1^2}{2} = 3.5\sigma_1^2$$

thus, $\sigma_1 = 56.69$ MPa. If $S_y = 75$ MPa and σ_1 , $\sigma_2 = \sigma_1/3$ and $\sigma_3 = -\sigma_1/2$ is the stress state, then

$$2(75)^2 = \sigma_1^2 - \frac{\sigma_1^2}{3} + \frac{\sigma_1^2}{3} - \frac{\sigma_1^2}{2} + \frac{\sigma_1^2}{2} - \sigma_1^2 = 2.72\sigma_1^2$$

Thus, $\sigma_1 = 64.3$ MPa. Therefore, the stress level to initiate yielding actually increases when σ_2 is increased.

2.86 A steel plate is 100 mm \times 100 mm \times 10 mm thick. It is subjected to biaxial tension $\sigma_1 = \sigma_2 = 350$ MPa, with the stress in the thickness direction of $\sigma_3 = 0$. What is the change in volume using Hooke's law?

From the inside front cover, it is noted that for steel we can use $E = 200$ GPa and $\nu = 0.30$. For a stress state of $\sigma_1 = \sigma_2 = 350$ MPa and $\sigma_3 = 0$, Equation (2.48) gives:

$$\begin{aligned} \Delta &= \frac{1-2\nu}{E} (\sigma_x + \sigma_y + \sigma_z) \\ &= \frac{1-2(0.3)}{200 \text{ GPa}} [(350 \text{ MPa}) + (350 \text{ MPa})] \\ &= 0.0014 \end{aligned}$$

Since the original volume is $(100)(100)(10) = 100,000$ mm³, the stressed volume is 100,140 mm³, or the volume change is $\Delta V = 140$ mm³.

For copper, we have $E = 125$ GPa and $\nu = 0.34$. Fol-

lowing the same derivation, the dilatation for copper is 0.0018; the stressed volume is 100,180 mm³ and thus the change in volume is $\Delta V = 180$ mm³.

The following Matlab code is helpful. Note that the values of E and ν need to be changed for each material considered.

```
I1=0.1;
I2=0.1;
```

2.87 A 50-mm-wide, 1-mm-thick strip is rolled to a final thickness of 0.5 mm. It is noted that the strip has increased in width to 51 mm. What is the strain in the rolling direction?

The thickness strain is given by Eq. (2.10) on p. 36 as

$$t = \ln \frac{1}{l_0} = \ln \frac{0.5 \text{ mm}}{1 \text{ mm}} = -0.693.$$

The width strain is

$$w = \ln \frac{l}{l_0} = \ln \frac{51 \text{ mm}}{50 \text{ mm}} = 0.0198.$$

Therefore, from Eq. (2.49) on p. 71, the strain in the rolling (or longitudinal) direction is $\epsilon_1 = 0 - 0.0198 + 0.693 = 0.6732$.

The following Matlab code is useful.

```
w0=0.050;
```

```
t0=0.001;
```

```
tf=0.0005;
```

```
wf=0.051;
```

```
et=log(tf/t0);
```

```
ew=log(wf/w0);
```

```
eI=0-et-ew;
```

2.88 An aluminum alloy yields at a stress of 50 MPa in uniaxial tension. If this material is subjected to the stresses $\sigma_1 = 25$ MPa, $\sigma_2 = 15$ MPa and $\sigma_3 = -26$ MPa, will it yield? Explain.

According to the maximum shear-stress criterion, the effective stress is given by Eq. (2.52) on p. 72 as:

$$\bar{\sigma} = \sigma_1 - \sigma_3 = 25 - (-26) = 51 \text{ MPa}$$

However, according to the distortion-energy criterion, the effective stress is given by Eq. (2.53) as:

$$\bar{\sigma} = \sqrt{\frac{1}{2} [(\sigma_1 - \sigma_2)^2 + (\sigma_2 - \sigma_3)^2 + (\sigma_3 - \sigma_1)^2]}$$

or

$$\bar{\sigma} = \sqrt{\frac{(25 - 15)^2 + (15 + 26)^2 + (-26 - 25)^2}{2}}$$

or $\bar{\sigma} = 46.8$ MPa. Therefore, the effective stress is

```
t=0.0
```

```
10;
```

```
s1=35
```

```
0e6;
```

```
s2=35
```

```

0e6; s3=0;
nu=0.30;
E=200e9;
Delta=(1-2*nu)/E*(s1+s2+s3);
V=11*12*t;
V2=V*(1+Delta);
DeltaV=V2-V;

```

higher than the yield stress for the maximum shear-stress criterion, and lower than the yield stress for the distortion-energy criterion. It is impossible to state whether or not the material will yield at this stress state. An accurate statement would be that yielding is imminent, if it is not already occurring.

The following Matlab code is helpful.

```

Sy=50e6;
s1=25e6;
s2=15e6;
s3=-26e6;
s_MSS=s1-s3;
se=1/((2)^0.5)*
    ((s1-s2)^2+(s2-s3)^2+(s3-s1)^2)^0.5;

```

2.89 A pure aluminum cylindrical specimen 25 mm in diameter and 25 mm high is being compressed by dropping a weight of 1000 N on it from a certain height.

After deformation, it is found that the temperature rise in the specimen is 50°C. Assuming no heat loss and no

friction, calculate the final height of the specimen. Use the following information for the material: $K = 205$

MPa, $n = 0.4$, $\rho = 7800 \text{ kg/m}^3$, and $c_p = 450 \text{ J/kg-K}$.

This problem uses the same approach as in Example

2.7 on p. 76. The volume of the specimen is

$$V = \frac{\pi d^2 h}{4} = \frac{\pi(0.025)^2(0.025)}{4} = 1.227 \times 10^{-5} \text{ m}^3$$

The expression for heat is given by

$$\begin{aligned} \text{Heat} &= c_p \rho V \Delta T \\ &= (450)(7800)(1.227 \times 10^{-5})(50) \\ &= 2150 \text{ J.} \end{aligned}$$

Since, ideally, from Eq. (2.59),

$$\begin{aligned} \text{Heat} = \text{Work} &= V u = V \frac{K}{n+1} \\ &= 1.227 \times 10^{-5} \frac{(205)^{1.4}}{1.4} \end{aligned}$$

Solving for u ,

$$1.4 = \frac{(1.4)(2150)}{1.1966 (1.227 \times 10^{-5})(205 \times 10^6)}$$

Therefore, $n = 1.13$. Using absolute values, we have

$$\ln \frac{h_o}{h_f} = \ln \frac{25 \text{ mm}}{h_f} = 1.13$$

Solving for h_f gives $h_f = 8.02 \text{ mm}$.

The following Matlab code confirms the answer and allows investigation of alternate values:

```
do=0.025;
ho=0.025;
W=1000;
DT=50;
K=205e6;
n=0.4;
```

```
rho=7800;
```

In the first step, we note that $h_o = 100 \text{ mm}$ and $h_1 = 70 \text{ mm}$, so that from Eq. (2.1) on p. 31,

$$e_1 = \frac{h_1 - h_o}{h_o} = \frac{70 - 100}{100} = -0.300$$

and from Eq. (2.9) on p. 36,

$$\epsilon_1 = \ln \frac{h_1}{h_o} = \ln \frac{70}{100} = -0.357$$

Similarly, for the second step where $h_1 = 70 \text{ mm}$ and $h_2 = 30 \text{ mm}$,

$$e_2 = \frac{h_2 - h_1}{h_1} = \frac{30 - 70}{70} = -0.571$$

$$\epsilon_2 = \ln \frac{h_2}{h_1} = \ln \frac{30}{70} = -0.847$$

Note that if the operation were conducted in one step, the following would result:

$$\begin{aligned} e &= \frac{h_2 - h_o}{h_o} = \frac{30 - 100}{100} = -0.7 \\ \epsilon &= \ln \frac{h_2}{h_o} = \ln \frac{30}{100} = -1.204 \end{aligned}$$

As was shown in Problem 2.49, this indicates that the true strains are additive while the engineering strains are not.

The following Matlab code can be used to consider other parameters.

```
ho=0.1;
h1=0.07;

h2=0.03;
e1=(h1-ho)/ho;
eps1=log(h1/ho);
e2=(h2-h1)/h1;
eps2=log(h2/h1);
etot=(h2-ho)/ho;
eps_tot=log(h2/ho);
```

2.91 Suppose the cylinder in Problem 2.90 has an initial diameter of 50 mm and is made of 1100-O aluminum. Determine the load required for each step.

From volume constancy, we calculate

$$\frac{\pi d_o^2 h_o}{4} = \frac{\pi d_f^2 h_f}{4}$$

$$c_p = 450;$$

$$V = \pi \cdot d_o^2 \cdot h_o / 4;$$

$$H = c_p \cdot \rho \cdot V \cdot \Delta T;$$

$$\epsilon = \left((1+n) \cdot H / V / K \right)^{1/(1+n)};$$

$$h_f = h_o / \exp(\epsilon);$$

2.90 A ductile metal cylinder 100 mm high is compressed to a final height of 30 mm in two steps between frictionless platens. After the first step the cylinder is 70 mm

high. Calculate both the engineering strain and the true strain for both steps, compare them, and comment on

your observations.

$$d_1 = d_o \sqrt{\frac{h_o}{h_1}} = 50 \sqrt{\frac{100}{70}} = 59.76 \text{ mm}$$

$$d_2 = d_o \sqrt{\frac{h_o}{h_2}} = 50 \sqrt{\frac{100}{30}} = 91.29 \text{ mm}$$

Based on these diameters the cross-sectional area at the steps is calculated as:

$$A_1 = \frac{\pi}{4} d_1^2 = 2.805 \times 10^{-3} \text{ m}^2$$

$$A_2 = \frac{\pi}{4} d_2^2 = 6.545 \times 10^{-3} \text{ m}^2$$

As calculated in Problem 2.90, $\epsilon_1 = 0.357$ and $\epsilon_{\text{total}} = 1.204$. Note that for 1100-O aluminum, $K = 180 \text{ MPa}$

and $n = 0.20$ (see Table 2.2 on p. 38) so that Eq. (2.11) on p. 36 yields

$$\sigma_1 = 180(0.357)^{0.20} = 146.5 \text{ MPa}$$

$$\sigma_2 = 180(1.204)^{0.20} = 186.8 \text{ MPa}$$

Therefore, the loads are calculated as:

$$P_1 = \sigma_1 A_1 = (146.5) (2.805 \times 10^{-3}) = 411 \text{ kN}$$

$$P_2 = (186.8)(6.545 \times 10^{-3}) = 1223$$

kN The following Matlab code is helpful.

```

ho=0.1;
h1=0.07;
h2=0.03;
e1=(h1-ho)/ho;

eps1=log(h1/ho);
e2=(h2-h1)/h1;
eps2=log(h2/h1);
etot=(h2-ho)/ho;
eps_tot=log(h2/ho);
do=0.050;
K=180e6; n=0.20;
d1=do*(ho/h1)^0.5;
d2=do*(ho/h2)^0.5;
A1=pi/4*d1*d1;

A2=pi/4*d2*d2;
sigma1=K*(abs(eps1)^n);
sigma2=K*(abs(eps_tot)^n)

P1=sigma1*A1;
P2=sigma2*A2;

```

2.92 Determine the specific energy and actual energy expended for the entire process described in the previous two problems.

From Eq. (2.57) on p. 73 and using $\sigma_{total} = 1.204$, $K = 180 \text{ MPa}$ and $n = 0.20$, we have

$$u = \frac{K}{n+1} = \frac{(180)(1.204)^{1.2}}{1.2} = 187 \text{ MPa}$$

2.93 A metal has a strain hardening exponent of 0.22. At a true strain of 0.2, the true stress is 80 MPa. (a) Determine the stress-strain relationship for this material. (b) Determine the ultimate tensile strength for this material.

(a) This solution follows the same approach as in Example 2.1 on p. 41. From Eq. (2.11) on p. 36, and recognizing that $n = 0.22$ and $\sigma = 80 \text{ MPa}$ for $\epsilon = 0.20$,

$$\sigma = K \epsilon^n \rightarrow 80 = K(0.20)^{0.22}$$

(b) To determine the ultimate tensile strength for the material, realize that the strain at necking is equal to the strain hardening exponent, or $\epsilon = n$. Therefore,

$$\sigma_{ult} = K(n)^n = 114(0.22)^{0.22} = 81.7 \text{ MPa}$$

Note that this is the true stress whereas S_{ut} is based on engineering stress. Therefore, the approach in Example 2.1 on p. 41 needs to be followed. The cross-sectional area at the onset of necking is obtained from

$$\ln \frac{A_o}{A_{neck}} = n = 0.22$$

Consequently,

$$A_{neck} = A_o e^{-0.22}$$

and the maximum load is

$$P = \sigma A = \sigma_{ult} A_{neck}$$

Hence,

$$P = (81.7)(A_o)e^{-0.22} = 65.6A_o$$

Since $S_{ut} = P/A_o$, we have

$$S_{ut} = \frac{65.6A_o}{A_o} = 65.6 \text{ MPa.}$$

The following Matlab code is helpful.

```

n=0.22; e=0.2;
sigma=80e6;
K=sigma/(e^n);
sigma_ut=K*n^n;
Sut=sigma_ut*exp(-n);

```

2

2.94 The area of each face of a metal cube is 5 cm^2 , and the metal has a shear yield strength k of 140 MPa . Compressive loads of 40 kN and 80 kN are applied to different faces (say in the x - and y - directions). What must be the compressive load applied to the z -direction to cause yielding according to the Tresca yield criterion? Assume a frictionless condition.

Since the area of each face is $5 \text{ cm}^2 = 5 \times 10^{-4} \text{ m}^2$, the stresses in the x - and y - directions are

$$\sigma_x = -\frac{40,000}{5 \times 10^{-4}} = -80 \text{ MPa}$$

$$\sigma_y = -\frac{80,000}{5 \times 10^{-4}} = -160 \text{ MPa}$$

or $K = 114$ MPa. Therefore, the stress-strain relationship for this material is

$$\sigma = 114 \epsilon^{0.22} \text{ MPa}$$

where the negative sign indicates that the stresses are compressive. If the Tresca criterion is used, then Eq. (2.38) on p. 67 gives

$$\sigma_{\max} - \sigma_{\min} = S_y = 2k = 280 \text{ MPa}$$

It is stated that σ_3 is compressive, and is therefore negative. Note that if σ_3 is zero, then the material does not yield because $\sigma_{\max} - \sigma_{\min} = 0 - (-160) = 160 \text{ MPa} < 280 \text{ MPa}$. Therefore, σ_3 must be lower than σ_2 , and is calculated from:

$$\sigma_{\max} - \sigma_{\min} = \sigma_1 - \sigma_3 = 280 \text{ MPa}$$

or

$$\sigma_3 = \sigma_1 - 280 = -80 - 280 = -360 \text{ MPa}$$

The compressive load is then

$$P = \sigma_3 A = -360 \times 10^6 \cdot 0.05 \times 10^{-4} = -180 \text{ kN.}$$

The following Matlab code is helpful.

```
A=5/100/100;
k=140e6;
Px=-40e3;
Py=-80e3;
sigma_x=Px/A;
sigma_y=Py/A;
Sy=2*k;
sigma_z=sigma_x-Sy;
P=sigma_z*A;
```

- 2.95** A tensile force of 9 kN is applied to the ends of a solid bar of 7.0 mm diameter. Under load, the diameter reduces to 5.00 mm. Assuming uniform deformation and volume constancy, (a) determine the engineering stress and strain; (b) determine the true stress and strain; (c) If the original bar had been subjected to a true stress of 345 MPa and the resulting diameter was 5.60 mm, what are the engineering stress and strain for this condition?

First note that, in this case, $d_o = 7 \text{ mm}$, $d_f = 5.00 \text{ mm}$, $P = 9000 \text{ N}$, and from volume constancy,

$$l_o d_o^2 = l_f d_f^2 \rightarrow \frac{l_f}{l_o} = \frac{d_o^2}{d_f^2} = \frac{7^2}{5.00^2} = 1.96$$

- (a) The engineering stress is calculated from Eq. (2.3) on p. 32 as:

$$s = \frac{P}{A_o} = \frac{9000}{\frac{\pi}{4}(0.007)^2} = 234 \text{ MPa}$$

and the engineering strain is calculated from

Eq. (2.1) as:

$$e = \frac{l - l_o}{l_o} = \frac{l_f}{l_o} - 1 = 1.96 - 1 = 0.96$$

- (b) The true stress is calculated from Eq. (2.8) on p. 35 as:

- (c) If the final diameter is $d_f = 5.60 \text{ mm}$, then the final area is $A_f = \frac{\pi}{4} d_f^2 = 24.63 \text{ mm}^2$. If the true stress is 345 MPa, then

$$P = \sigma A = (345)(24.63) = 8497 \approx 8500 \text{ N}$$

Therefore, the engineering stress is calculated as before as

$$\sigma = \frac{P}{A} = \frac{8500}{\frac{\pi}{4}(0.0056)^2} = 345 \text{ MPa}$$

Similarly, from volume constancy,

$$\frac{l_f}{l_o} = \frac{d_o^2}{d_f^2} = \frac{7^2}{5.60^2} = 1.5625$$

Therefore, the engineering strain is

$$e = \frac{l_f}{l_o} - 1 = 1.5625 - 1 = 0.5625$$

The following Matlab code is useful for parts (a) and (b).

```
df=0.005;
do=0.007;
Ao=pi*do*do/4;
Af=pi*df*df/4;
P=9000;
lr=do*do/df/df;
s=P/Ao;
e=lr-1;
sigma=P/Af;
eps=log(lr);
```

- 2.96** Two identical specimens 20 mm in diameter and with test sections 25 mm long are made of 1112 steel. One is in the as-received condition and the other is annealed. (a) What will be the true strain when necking occurs, and what will be the elongation of these samples at that

instant? (b) Find the ultimate tensile strength for these materials.

This problem uses a similar approach as for Example 2.1 on p. 41. First, we note from Table 2.2 on p. 38 that for cold-rolled 1112 steel, $K = 760 \text{ MPa}$

and $n = 0.08$. Also, the initial cross-sectional area is $A_o = \frac{\pi}{4} (0.020)^2 = 3.142 \times 10^{-4} \text{ m}^2$. For annealed 1112

steel, $K = 760 \text{ MPa}$ and $n = 0.19$. At necking, $\epsilon = n$, so that the strain will be $\epsilon = 0.08$ for the cold-rolled steel and $\epsilon = 0.19$ for the annealed steel. For the cold-rolled steel, the final length is given by Eq. (2.9) on p. 36 as

$$l = l_o e^{\epsilon} = l_o \ln \frac{l_f}{l_o}$$

$$\sigma = \frac{P}{A} = \frac{9000}{\frac{\pi}{4}(5.00)^2} = 458 \text{ MPa}$$

and the true strain is calculated from Eq. (2.9) on p. 36 as:

$$= \ln \frac{l_f}{l_o} = \ln 1.96 = 0.673$$

Solving for l_f ,

$$l_f = e^n l_o = e^{0.08}(25) = 27.08 \text{ mm}$$

The elongation is, from Eq. (2.6) on p. 35,

$$\text{Elongation} = \frac{l_f - l_o}{l_o} \times 100 = \frac{27.08 - 25}{25} \times 100$$

or 8.32%. To calculate the ultimate strength, we can write, for the cold-rolled steel,

$$S_{ut,true} = \sigma_{ut} = K n^n = 760(0.08)^{0.08} = 621 \text{ MPa}$$

As in Example 2.1 on p. 41, we calculate the load at necking as:

$$P = \sigma_{ut} A_o e^{-n}$$

So that

$$S_{ut} = \frac{P}{A_o} = \frac{S_{ut,true} A_o e^{-n}}{A_o} = S_{ut,true} e^{-n}$$

This expression is evaluated as

$$S_{ut} = (621)e^{-0.08} = 573 \text{ MPa.}$$

Repeating these calculations for the annealed specimen yields $l = 30.23 \text{ mm}$, **elongation = 20.9%**, and $S_{ut} = 458$

MPa.

The following Matlab code is useful, and can be used

to prove the calculations for the annealed specimen are correct by using $n = 0.19$.

`do=0.020;`

`K=760e6;`
`n=0.08;`

`Ao=pi*do*do/4;`
`lf=exp(n)*lo;`
`elongation=(lf-lo)/lo*100;`
`sigma_ut=K*n^n;`
`P=sigma_ut*Ao*exp(-n);`
`Sut=sigma_ut*exp(-n);`

2.97 During the production of a part, a metal with a yield

strength of 200 MPa is subjected to a stress state σ_1 , $\sigma_2 = \sigma_1/3$, $\sigma_3 = 0$. Sketch the Mohr's circle diagram for this stress state. Determine the stress σ_1 necessary to cause yielding by the maximum shear stress and the von Mises criteria.

For the stress state of σ_1 , $\sigma_1/3$, 0 the following figure the three-dimensional Mohr's circle:

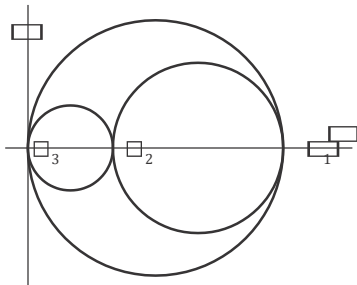

For the von Mises criterion, Eq. (2.39) on p. 67 gives:

$$2S_y^2 = \frac{\sigma_1}{3} \left[(\sigma_1 - \sigma_2)^2 + (\sigma_2 - \sigma_3)^2 + (\sigma_3 - \sigma_1)^2 \right]$$

Solving for σ_1 gives $\sigma_1 = 227 \text{ MPa}$. According to the Tresca criterion, Eq. (2.42) on p. 69 gives

$$\sigma_1 - \sigma_3 = \sigma_1 = 0 = S_y$$

or $\sigma_1 = 200 \text{ MPa}$.

2.98 The following data are taken from a stainless steel tension-test specimen:

Load P (kN)	Extension Δl (mm)
7.10	0
11.1	0.50
13.3	2.0
16.0	5.0
18.7	10
20.0	15.2
20.5 (max)	21.5
14.7 (fracture)	25

Also, $A_o = 3.5 \times 10^{-5} \text{ m}^2$, $A_f = 1.0 \times 10^{-5} \text{ in}^2$, $l_o = 50$

mm. Plot the true stress-true strain curve for the material.

The following are calculated from Eqs. (2.6), (2.9), (2.10), and (2.8):

Δl (mm)	l (mm)	A (m ²)	σ (MPa)	
0	50	0	3.50×10^{-5}	203
0.50	50.50	0.00995	3.46×10^{-5}	321
2.0	52.0	0.0392	3.36×10^{-5}	396
5.0	55.0	0.0953	3.18×10^{-5}	503
10	60.0	0.182	2.92×10^{-5}	640
15.2	65.2	0.262	2.69×10^{-5}	743
21.5	71.5	0.357	2.45×10^{-5}	837
25	75	0.405	2.33×10^{-5}	631

The true stress-true strain curve is then plotted as follows:

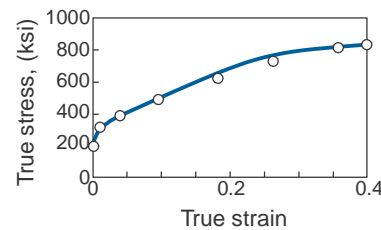

2.99 A metal is yielding plastically under the stress state shown.

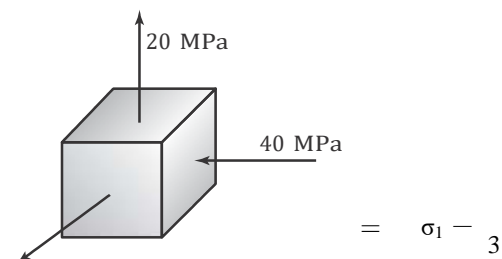

$$\begin{aligned}
 & 4 \sigma_1^2 + \frac{\sigma_1^2}{3} + (0 - \sigma_1)^2 \\
 = & \frac{4}{9} \sigma^2 + \frac{1}{9} \sigma^2 + \frac{1}{3} \sigma^2 = \frac{14}{9} \sigma^2
 \end{aligned}$$

50 MPa

- (a) Label the principal axes according to their proper numerical convention (1, 2, 3).
- (b) What is the yield strength using the Tresca criterion?
- (c) What if the von Mises criterion is used?
- (d) The stress state causes measured strains of $\epsilon_1 = 0.4$ and $\epsilon_2 = 0.1$, with ϵ_3 not being measured. What is the value of ϵ_3 ?

- (a) The 1-direction corresponds to the 50 MPa stress, the 2 direction corresponds to the 20 MPa stress, and the 3 direction corresponds to the -40 MPa stress.
- (b) Since $\sigma_1 \geq \sigma_2 \geq \sigma_3$, then from the figure $\sigma_1 = 50$ MPa, $\sigma_2 = 20$ MPa and $\sigma_3 = -40$ MPa.
- (c) The yield stress using the Tresca criterion is given by Eq. (2.38) on p. 67 as

$$\sigma_{\max} - \sigma_{\min} = S_y$$

So that

$$S_y = 50 \text{ MPa} - (-40 \text{ MPa}) = 90 \text{ MPa.}$$

- (d) If the von Mises criterion is used, then Eq. (2.39) gives

$$(\sigma_1 - \sigma_2)^2 + (\sigma_2 - \sigma_3)^2 + (\sigma_3 - \sigma_1)^2 = 2S_y^2$$

or

$$2S_y^2 = (50 - 20)^2 + (20 + 40)^2 + (50 + 40)^2$$

or

$$2S_y^2 = 12,600$$

which is solved as $S_y = 79.4 \text{ MPa.}$

- (d) If the material is deforming plastically, then from Eq. (2.49) on p. 71,

$$\epsilon_1 + \epsilon_2 + \epsilon_3 = 0.4 + 0.2 + \epsilon_3 = 0$$

or $\epsilon_3 = -0.6$.

The following Matlab code is useful.

```
s1=50e6;
s2=20e6;
s3=-40e6;
Sy_T=s1-s3;
se=(s1-s2)^2+(s2-s3)^2+(s3-s1)^2;
Sy_vM=(se/2)^(0.5);
```

- 2.100** Estimate the depth of penetration in a Brinell hardness test using 500 kg as the load when the sample is a cold-worked aluminum with a yield strength of 150 MPa.

can estimate the diameter of the indentation from the expression:

$$HB = \frac{2P}{(\pi D)(D - \sqrt{D^2 - d^2})}$$

from which we find that $d = 3.51 \text{ mm}$ for $D = 10 \text{ mm}$. To calculate the depth of penetration, consider the following sketch:

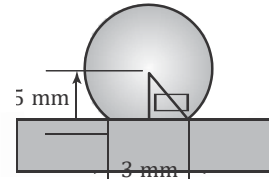

Because the radius is 5 mm and one-half the penetration diameter is 1.755 mm, we can obtain α as

$$\alpha = \sin^{-1} \frac{1.755}{5} = 20.5^\circ$$

The depth of penetration, t , can be obtained from

$$t = 5 - 5 \cos \alpha = 5 - 5 \cos 20.5^\circ = 0.318 \text{ mm}$$

- 2.101** It has been proposed to modify the von Mises yield criterion as:

$$(\sigma_1 - \sigma_2)^a + (\sigma_2 - \sigma_3)^a + (\sigma_3 - \sigma_1)^a = C$$

where C is a constant and a is an even integer larger than 2. Plot this yield criterion for $a = 4$ and $a = 12$, along with the Tresca and von Mises criterion, in plane stress. (Hint: See Fig. 2.32).

For plane stress, one of the stresses, say σ_3 , is zero, and the other stresses are σ_A and σ_B . The yield criterion is then

$$(\sigma_A - \sigma_B)^a + (\sigma_B)^a + (\sigma_A)^a = C$$

Note from Fig. 2.22 on p. 57 that for cold-worked aluminum with a yield stress of 150 MPa, the Brinell hardness is around 50 kg/mm². From Fig. 2.20 on p. 54, we

For uniaxial tension, $\sigma_A = S_y$ and $\sigma_B = 0$ so that $C = 2S^a$. These equations are difficult to solve by hand; the following solution was obtained using a mathematical programming package:

von Mises B
 $a=4$ Y
 $a=12$
 Tresca

A
 Y

y

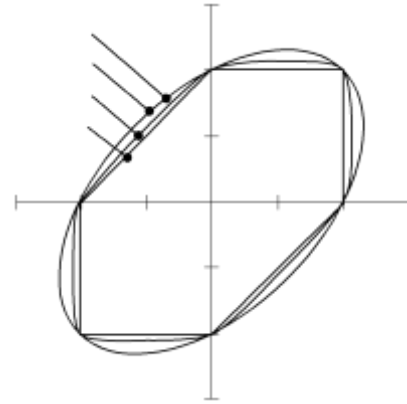

Note that the solution for $a = 2$ (von Mises) and $a = 4$ are so close that they cannot be distinguished in the plot. When zoomed into a portion of the curve, one would see that the $a = 4$ curve lies between the von Mises curve and the $a = 12$ curve.

2.102 Assume that you are asked to give a quiz to students on the contents of this chapter. Prepare three quantitative

problems and three qualitative questions, and supply the answers.

By the student. This is a challenging, open-ended question that requires considerable focus and understanding on the part of the student, and has been found to be a very valuable homework problem.