

## Solution Manual for Materials Science and Engineering Properties 1st Edition

Gilmore 1111988609 9781111988609

Full link download:

<https://testbankpack.com/p/solution-manual-for-materials-science-and-engineering-properties-1st-edition-gilmore-1111988609-9781111988609/>

### Chapter 2 Atoms, Chemical Bonding, Material Structure, and Physical Properties Homework Solutions

#### Concept Questions

1. The *Pauli exclusion* principle says that no two electrons that occupy the same space can have the same quantum numbers.
2. The quantum numbers of electrons on an atom include the principal quantum number, the angular-momentum quantum number, the magnetic quantum number, and the *spin* quantum number of  $\pm 1/2$ .
3. The *valence* electrons of an atom are the electrons in an incomplete electron shell that are outside of a spherically symmetric closed electron shell corresponding to an inert-gas atom.
4. The *group* number in the periodic table is equal to an element's number of valence electrons.
5. The inert-gas atoms have the group number of *zero*.
6. Atoms chemically bond to achieve an electron configuration as similar as possible to that of the *inert gas* atoms.
7. If a ceramic has strong chemical bonding, the ceramic has a(n) *high* melting temperature.
8. Hardness is a measure of a material's resistance to mechanical *penetration*.
9. If a metal has a low cohesive energy, the metal is expected to have a *low* hardness.
10. The primary bonding between different H<sub>2</sub>O molecules in water is a *permanent* electric dipole bond.
11. The bond between different inert-gas atoms in liquids and solids is the *fluctuating* electric dipole bond.
12. An element has metallic bonding when the valence electron shell is *less* than half filled.
13. In metallic bonding, the valence electrons are *free* electrons.

14. Ideal metals form close-packed crystal structures because the positive ion cores pack like spherical billiard balls.
- 15.
15. The density of metals is high relative to their atomic weights, in comparison to covalently bonded materials with the same interatomic spacing.
16. The unit cell is a small group of atoms that contains all of the necessary information about the crystal that when repeated in space produces the crystal.
17. Lattice points in a Bravais lattice are equivalent points in space.
18. A primitive unit cell contains one lattice point(s).
19. The eight corners of a cubic lattice unit cell contribute one lattice point(s) to the unit cell.
20. The six face-centered lattice points of a FCC lattice unit cell contribute three lattice point(s) to a unit cell.
21. A BCC unit cell contains two lattice point(s).
22. The Miller indices of a plane are the inverse of the intercepts of the plane along the unit cell axes.
23. The {100} planes of a cubic unit cell form the faces of the cube.
24. The close-packed planes in a FCC metal are the {111} family of planes.
25. The planar atom density of the (100) plane of a FCC metal is two atoms divided by the square of the lattice parameter.
26. In a BCC metal, the <111> family of directions is the most closely packed.
27. The linear atom density of the [110] direction for a FCC metal is two atoms divided by the length of the face diagonal.
28. If there is only one atom type and the valence shell is one-half filled or more, then the atoms share electrons in a covalent bond.
29. An atom in face centered cubic aluminum has twelve nearest neighbors.
30. A carbon nanotube is a single sheet of graphite rolled into a tube.
31. The mer of polyethylene is made from two atoms of carbon and two atoms of hydrogen.
32. In a polyethylene long-chain molecule, the carbon-carbon and hydrogen-carbon bonds are all covalent bonds.

33. If liquid PMMA is rapidly cooled to room temperature, the structure is amorphous.
34. In vulcanized rubber, sulfur atoms crosslink the latex long-chain molecules.
35. Polyethylene is mechanically soft because different long-chain molecules in polyethylene are held together with weak van der Waals bonds.
36. OUEHMWPE fibers are high in strength because the LCMs are oriented parallel to the fiber axis.
37. In ionic bonding, electrons are transferred from an atom with its valence shell less than half filled to an atom with the valence shell more than half filled.
38. The atom arrangement in liquid copper is amorphous, with no long-range order.
39. It is possible to cool liquid copper sufficiently fast to form an amorphous structure. True or false?
40. When polyethylene is melted, the only bonds that are broken are the weak van der Waals bonds between the long-chain molecules.
41. In silica glass ( $\text{SiO}_2$ ), there is no long-range order, but there is short-range order.
42. Glass at room temperature is not a liquid, it is a solid because it can resist a change in shape.
43. During a rapid cool, liquid  $\text{SiO}_2$  solidifies into glass because of its complex structure.
44. During heating, an amorphous material starts to soften at the glass transition temperature.
45. The atom pair bond energy as a function of interatomic separation is the interatomic pair potential.
46. The equilibrium interatomic separation between two atoms is determined by setting the derivative of the interatomic pair potential with respect to separation equal to zero.
47. In an ionic material, the coulombic potential is the attractive energy between ions.
48. The bond energy of a pair of atoms is equal to the depth of the interatomic potential at the equilibrium interatomic separation.
49. Covalently bonded materials cannot be modeled with pair potentials, because the pair potential energy is only a function of interatomic separation.

50. The element rubidium (Rb, atomic number 37) is in Group IA of the periodic table, thus the chemical bonding should be metallic.

51. The element rubidium (Rb, atomic number 37) is in Group IA of the periodic table, and the element chlorine (Cl, atomic number 17) is in Group VIIB of the periodic table. RbCl should have ionic bonding.

52. The molecular weight of a long-chain molecule is equal to the molecular weight of a mer unit times the number of mer units.

### Engineer in Training-Style Questions

1. Which of the following types of chemical bond is not a primary bond type?

- (a) Covalent
- (b) Fluctuating- electric dipole
- (c) Metallic
- (d) Ionic

2. If the principal quantum number ( $n$ ) is equal to 3, which of the following angular momentum quantum numbers ( $l$ ) is not allowed?

- (a) 0
- (b) 1
- (c) 2
- (d) 3

3. The energy of an electron on an atom that is not in a magnetic field is not dependent upon which of the following?

- (a) Charge on the nucleus
- (b) Spin quantum number
- (c) Angular momentum quantum number
- (d) Principle quantum number

4. The radius of an atom is typically:

- (a)  $10^{-6}$  m
- (b)  $10^{-10}$  m
- (c)  $10^{-15}$  m
- (d)  $10^{-18}$  m

5. The radius of a nucleus is typically:

- (a)  $10^{-6}$  m
- (b)  $10^{-10}$  m
- (c)  $10^{-15}$  m
- (d)  $10^{-18}$  m

6. The electronegativity of the inert-gas atoms is equal to:  
*(a) undefined*  
(b) 0  
(c) 1  
(d) 2
7. In a tetragonal unit cell,  $a=b$  but  $c$  is not equivalent. Which plane is therefore not equivalent?  
(a) (100)  
(b) (010)  
(c) (0 $\bar{1}$ 0)  
*(d) (001)*
8. Which of the following is not associated with a solid that has covalent bonding?  
(a) Localized valence electrons  
(b) High cohesive energy  
*(c) Close-packing of atoms*  
(d) Low density relative to molar weight
9. Which of the following physical properties is not associated with a solid that has covalent bonding between all atoms?  
*(a) Low melting temperature*  
(b) High hardness  
(c) Electrical insulator  
(d) Brittle fracture
10. Which of the following is not associated with van der Waals bonds?  
(a) Fluctuating- electric dipoles  
*(b) Electron transfer*  
(c) Permanent- electric dipoles  
(d) Relatively low melting temperature
11. Which of the following is not an allotropic form of carbon?  
*(a) Ethylene*  
(b) Diamond  
(c) Buckyball  
(d) Graphene
12. Which of the following is not a thermoplastic polymer?  
(a) Polyethylene  
*(b) Epoxy*  
(c) Polyvinylchloride  
(d) Polypropylene

13. Which of the following does not increase the strength of a polymer?

- (a) Orienting molecules
- (b) High molecular weight
- (c) Cross-links
- (d) Plasticizers

### Design-Related Questions

1. If you have to select a material and the primary requirement is a high melting temperature, what class of material would you investigate first for suitability? ceramics
2. If low density is the primary design requirement, what class of material discussed in this chapter would you first investigate for suitability? polymers
3. You have to select a material as a coating on an aluminum part that improves the wear and abrasion resistance of the part. What class of material would you investigate first for suitability? ceramics
4. You are asked to select a material for a barge tow line that must be as strong as steel cable, but can float on water and is not corroded by salt water. What material discussed in this chapter might be suitable? OUHMWPE
5. Aluminum (Group III) and silicon (Group IV) are adjacent to each other in the periodic table. Relative to aluminum silicon is less dense, has a higher melting temperature, is harder, and is very prevalent in the sand and rocks of the Earth's crust. And yet aluminum has many more mechanical applications, such as in the structure and skin of aircraft, the cylinder heads in automobile engines, small boats, and marine engines. We will cover this later in the book, but from what you know about metals, such as aluminum, what property results in the use of aluminum in these applications rather than silicon? ductility

### Problems

**Problem 2.1:** How many atoms are there in a face centered cubic unit cell that has an atom at 0, 0, 0?

**Solution:**

The atoms at each of the eight corners of the cube contribute 1/8 of an atom to the unit cell for a total of one atom contributed by the corner atoms of the cube.

The atom at the face centered position of each face is  $1/2$  in the unit cell, and there are 6 faces for a total of 3 atoms contributed by the 6 face centered atoms. The total number of atoms in the unit cell is  $3+1$  for a total of 4.

**Problem 2.2:** The compound  $\text{Ni}_3\text{Al}$  is used to strengthen nickel based alloys used in high temperature gas turbine materials. The crystal structure of  $\text{Ni}_3\text{Al}$  is a cube with Al atoms at the eight cube corners and Ni at all of the cube face centers. (a) What is the Bravais lattice type for  $\text{Ni}_3\text{Al}$  and (b) What are the atom positions?

**Solution:**

(a) Simple cubic because the Ni atoms at the face centered positions are not equivalent to the Al atoms at the corners. Therefore, only the corner atom positions are equivalent and this corresponds to the simple cubic lattice.

(b) Al-0,0,0 Assigning an atom to 0,0,0 also automatically places atoms at all of the equivalent 8 corners of the cube.

Ni-1/2,1/2,0 0,1/2,1/2 1/2,0,1/2

Placing atoms at these three face centers also places an atom at the equivalent face on the other side of the unit cell. The other side of the unit cell is the equivalent face in the next unit cell.

**Problem 2.3:** Calculate the number of atoms per unit volume in face centered cubic (FCC) silver (Ag) assuming that the lattice parameter (a) for Ag is 0.407 nm.

**Solution:**

Since Ag is cubic the volume of a unit cell is

$$a^3 = (0.407 \times 10^{-9} \text{ m})^3 = 0.0674 \times 10^{-27} \text{ m}^3$$

In the unit cell there are four atoms, thus the number of atoms per unit volume ( $n_a$ ) is

$$n = \frac{4 \text{ atoms}}{0.0674 \times 10^{-27} \text{ m}^3} = 59.33 \times 10^{27} \text{ atoms/m}^3$$

**Problem 2.4:** Calculate the number of atoms per unit volume in BCC solid sodium (Na) assuming that the lattice parameter for sodium is 0.428 nm.

**Solution:**

Since sodium is BCC the volume of a unit cell is

$$a^3 = (0.428 \times 10^{-9} \text{ m})^3 = 0.0784 \times 10^{-27} \text{ m}^3$$

In the unit cell there are two atoms, thus the number of atoms per unit volume ( $n_a$ ) is

$$n = \frac{2 \text{ atoms}}{0.0784 \times 10^{-27} \text{ m}^3} = 25.51 \times 10^{27} \text{ atoms/m}^3$$



**Problem 2.5:** The density of silver at room temperature is  $10.49 \text{ g/cm}^3$ . You need to know the density of solid silver just below the melting temperature. At  $960^\circ\text{C}$  the lattice parameter was measured to be  $0.4176 \text{ nm}$ . Compare the theoretical density of silver at  $960^\circ\text{C}$  to that at room temperature.

**Solution:**

The theoretical density can be calculated from the weight of silver atoms in a single unit cell divided by the volume of a unit cell. Silver is FCC therefore there are 4 atoms per unit cell. The number of atoms per unit volume is:

$$n_a = \frac{4 \text{ atoms}}{(0.4176 \times 10^{-9})^3 \text{ m}^3} = \frac{4 \text{ atoms}}{(0.0728 \times 10^{-27}) \text{ m}^3} = 54.93 \times 10^{27} \frac{\text{atoms}}{\text{m}^3}$$

$$\rho_{Ag} = \frac{N_A}{n_a} = 54.93 \times 10^{27} \frac{\text{atoms}}{\text{m}^3} \frac{6.02 \times 10^{23} \text{ atoms}}{\text{mole}} \frac{107.87 \times 10^{-3} \text{ kg}}{\text{mole}} = 984.2 \times 10^3 \frac{\text{kg}}{\text{m}^3}$$

At  $960^\circ\text{C}$  the density is  $\rho_{Ag} = 9.84 \times 10^3 \text{ kg/m}^3$  in comparison to  $10.49 \times 10^3 \text{ kg/cm}^3$  at room temperature.

**Problem 2.6:**

The density of iron at room temperature is listed as  $7.87 \text{ g/cm}^3$  in Appendix B. The density of the FCC ( $\gamma$ ) phase at temperatures above  $912^\circ\text{C}$  is not listed. Calculate the theoretical density of FCC iron based upon the listed lattice parameter of  $0.3589 \text{ nm}$ .

**Solution:**

$$n_a = \frac{4 \text{ atoms}}{(0.3589 \times 10^{-9})^3 \text{ m}^3} = \frac{4 \text{ atoms}}{(0.04623 \times 10^{-27}) \text{ m}^3} = 86.52 \times 10^{27} \frac{\text{atoms}}{\text{m}^3}$$

$$\rho_{\gamma Fe} = \frac{n_a}{N_A} = 86.52 \times 10^{27} \frac{\text{atoms}}{\text{m}^3} \frac{6.02 \times 10^{23} \text{ atoms}}{\text{mole}} \frac{55.85 \times 10^{-3} \text{ kg}}{\text{mole}} = 80.27 \times 10^3 \frac{\text{kg}}{\text{m}^3}$$

$$\rho_{\gamma Fe} = 8.027 \times 10^3 \frac{\text{kg}}{\text{m}^3}$$

The density increases for the FCC high temperature phase. This is due to the FCC phase being close packed and the BCC phase is not close packed.

**Problem 2.7:** Nanoparticles are finding many applications including medicine, magnetic permanent memory, and high strength materials. Assume that a high strength nickel alloy is to be made out of nanoparticles, and that the size of the nanoparticles is a cube 10 nm on each side. Calculate the number of atoms in these particles in two ways. (a) For face centered cubic nickel calculate the number of atoms using only the lattice parameter of 0.352 nm from Appendix B and (b) using the density of nickel and the atomic mass from Appendix B.

**Solution:**

(a) Nickel is face centered cubic, the volume of a cubic unit cell is

The volume of a cube 10 nm on each side is

$$V = (10 \text{ nm})^3 = 1000 \text{ nm}^3 = 1000 \times 10^{-27} \text{ m}^3 = 1.0 \times 10^{-26} \text{ m}^3$$

$$\text{The volume of a unit cell is } a^3 = (0.352 \times 10^{-9} \text{ m})^3 = 0.044 \times 10^{-27} \text{ m}^3$$

In the face centered cubic unit cell there are four atoms, thus the number of atoms per unit volume ( $n_a$ ) is

$$n_a = \frac{4 \text{ atoms}}{0.044 \times 10^{-27} \text{ m}^3} = 91.7 \times 10^{27} \frac{\text{atoms}}{\text{m}^3}$$

The number of atoms  $N$  in the volume  $V$  is then

$$N = V n_a = 1.0 \times 10^{-26} \text{ m}^3 \cdot 91.7 \times 10^{27} \frac{\text{atoms}}{\text{m}^3} = 91.7 \times 10 \text{ atoms} = 917 \text{ atoms}$$

$$N = 917 \text{ atoms}$$

(b) Calculate the number of atoms per unit volume ( $N_V$ ) using the mass of one mole of nickel atoms ( $M_{Ni}$ ) of 58.71 gm and the density  $\rho_{Ni}$  is 8.902 gm/cm<sup>3</sup>. Using dimensional analysis or the equation

$$N_V = \frac{\rho}{M_{Ni}} N_A = 8.902 \frac{\text{g}}{\text{cm}^3} \cdot \frac{1 \text{ mole}}{58.71 \text{ g}} \cdot 6.02 \times 10^{23} \frac{\text{atoms}}{\text{mole}} \cdot \frac{\text{cm}^3}{10^6 \text{ m}^3} = 0.913 \times 10^{29} \frac{\text{atoms}}{\text{m}^3}$$

$$N = V N_V = 1.0 \times 10^{-26} \text{ m}^3 \cdot 0.913 \times 10^{29} \frac{\text{atoms}}{\text{m}^3} = 913 \text{ atoms}$$

The difference is due to round off errors.

**Problem 2.8:** Silicon is FCC with an atom at 0,0,0 and an atom at 1/4,1/4,1/4 and a lattice parameter of 0.543 nm. (a) How many atoms are there in this FCC unit cell? (b) Calculate the number of atoms per unit volume based upon the unit cell. (c) Calculate the number of atoms per unit volume based upon the density of  $2.33 \times 10^3 \text{ kg/m}^3$ .

**Solution:**

(a) The atom at 0,0,0 in the FCC structure contributes 4 atoms to the unit cell. One atom from the corners and 3 atoms from the face centers. Associated with each atom in corner and face centered positions is another atom a distance of  $\frac{1}{4}, \frac{1}{4}, \frac{1}{4}$  away. These atoms contribute 4 more atoms to the unit cell for a total of 8 atoms.

$$(b) \frac{8 \text{ atoms}}{\text{unit cell}} = \frac{8 \text{ atoms}}{\text{unit cell}} = 50 \times 10^{27} \frac{\text{atoms}}{\text{m}^3} = 0.5 \times 10^{29} \frac{\text{atoms}}{\text{m}^3}$$

$$(c) \frac{2.33 \frac{\text{g}}{\text{cm}^3} \cdot \frac{1 \text{ mole}}{28.09 \text{ g}}}{6.02 \times 10^{23} \frac{\text{atoms}}{\text{mole}}} \cdot \frac{0.16 \times 10^{-27} \text{ m}^3}{10^{-6} \text{ cm}^3} = 0.5 \times 10^{29} \frac{\text{atoms}}{\text{m}^3}$$

**Problem 2.9:** Diamond is FCC with a lattice parameter of 0.357 nm and atoms located at 0,0,0 and at 1/4,1/4,1/4, and these two atoms are nearest neighbors. Calculate the atomic radius of a carbon atom in diamond, assuming that the radii touch between nearest neighbors.

**Solution:**

The atomic diameter ( $2R$ ) is equal to the distance between the two atoms at 0,0,0 and  $\frac{1}{4}, \frac{1}{4}, \frac{1}{4}$  and this distance ( $2R$ ) is equal to  $\frac{1}{4}$  of the distance along the body diagonal of the cubic unit cell. The body diagonal is thus equal to  $8R$ .

$$8R = 0.357 \text{ nm}(3)^{1/2} = 0.618 \text{ nm}$$

$$R = \frac{0.618 \text{ nm}}{8} = 0.077 \text{ nm}$$

**Problem 2.10:** In an orthorhombic unit cell with  $a < b < c$ , draw the following planes:  $(001)$ ,  $(101)$ ,  $(01\bar{0})$ ,  $(132)$ ,  $(112)^{-}$ , and  $(11\bar{0})$ . Label each plane, and show the intercepts of the plane with the  $x$ ,  $y$ , and  $z$  axes in the unit cell.

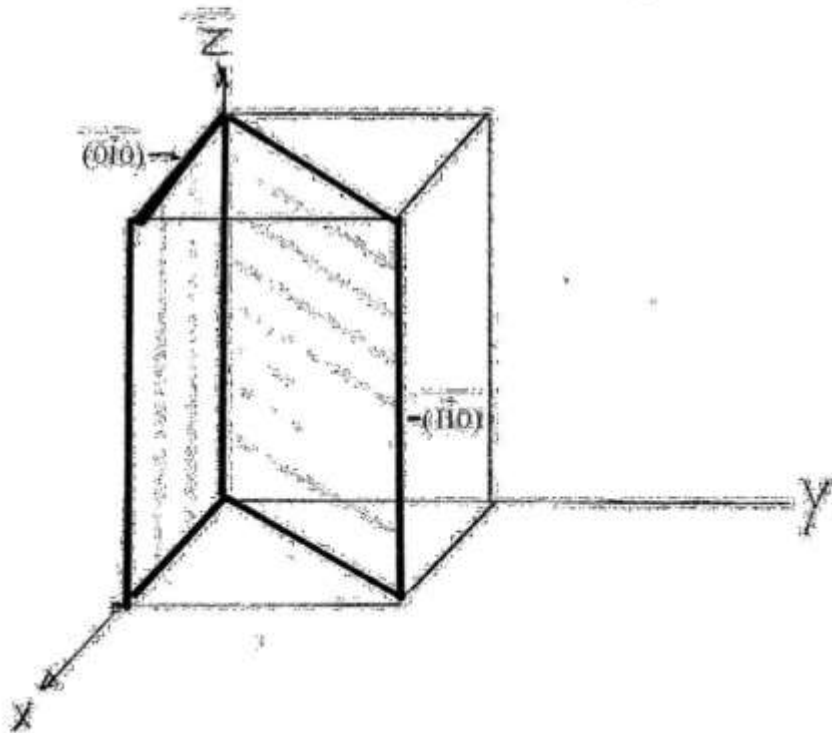
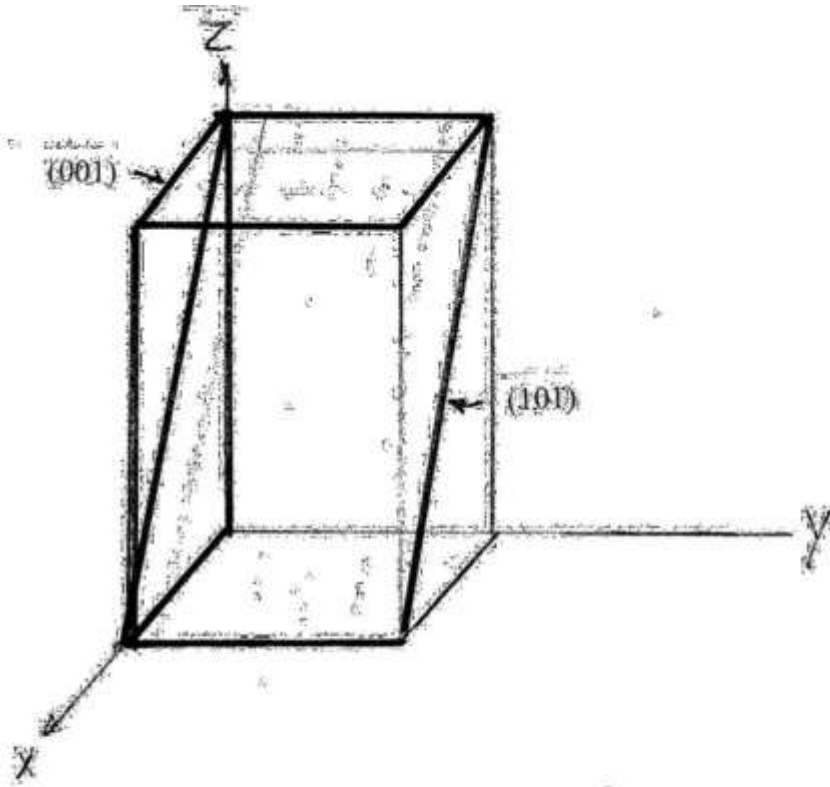

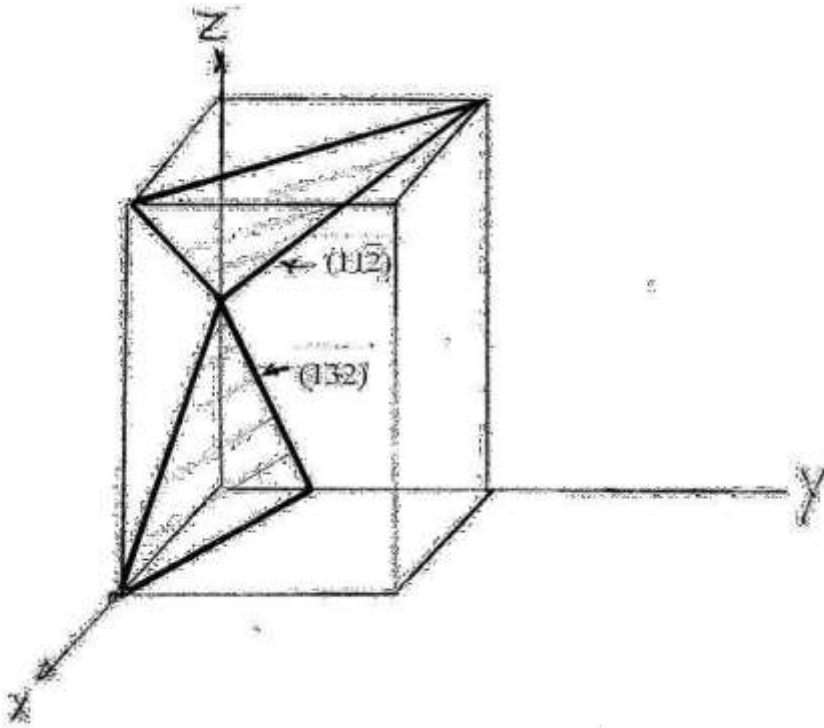

**Problem 2.11:** In the BCC metal iron, the (110)-type planes are the most closely packed planes.

- Calculate the interplanar spacing between the (110)-type planes.
- Draw a BCC unit cell and show the (110)-type planes and a [110] direction that is perpendicular to the (110) planes.
- Calculate the segment lengths where the (110) planes cut the [110] direction.

**Solution:**

From Appendix B the lattice parameter ( $a$ ) of iron is 0.2866 nm

$$(a) \quad d_{hkl} = \frac{a}{\sqrt{h^2 + k^2 + l^2}} = \frac{0.2866 \text{ nm}}{\sqrt{1^2 + 1^2 + 0}} = \frac{0.2866 \text{ nm}}{\sqrt{2}} = \frac{0.2866 \text{ nm}}{1.414} = 0.203 \text{ nm}$$

(b) Draw a (110) and [110] in a cubic unit cell.

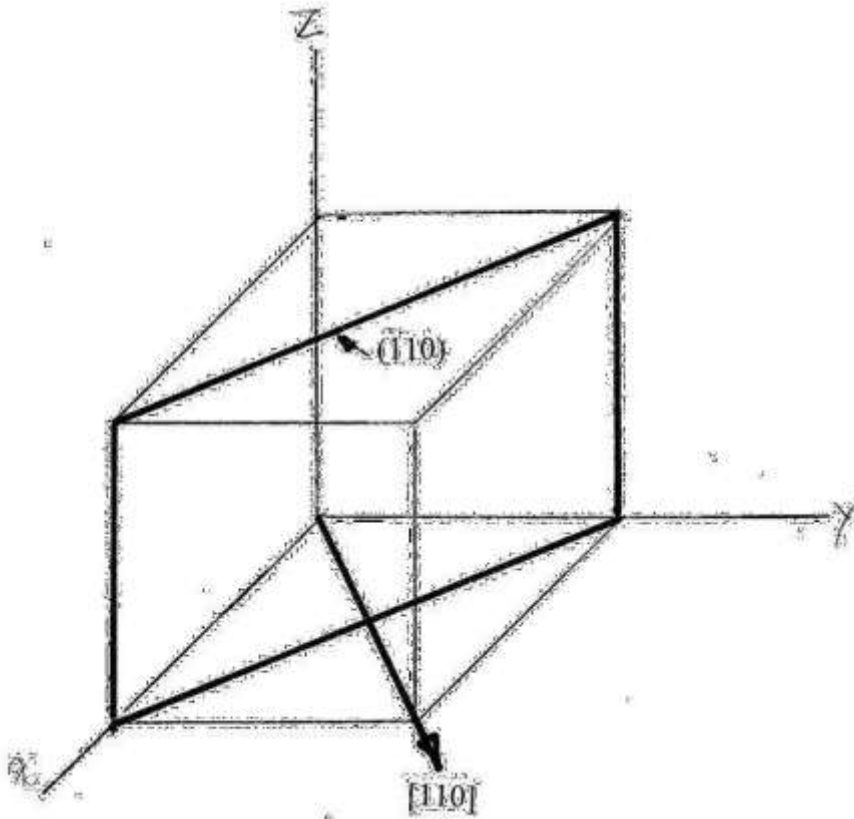

(c) Starting at the position 0, 0, 0 and going to the position 1, 1, 0 the [110] direction is sliced into two segments. There is a (110) plane that surrounds the atoms both at 0, 0, 0 and at 1, 1, 0. The distance from 0, 0, 0 to 1, 1, 0 is  $a2^{1/2}$ , but the spacing between planes is 1/2 of this value, because the (111) planes cut this distance into two segments. Thus the spacing between the (110) planes is

$$\frac{a}{2^{1/2}} = \frac{0.2866 \text{ nm}}{1.414} = 0.203 \text{ nm}$$

This result is in agreement with the result obtained using Equation 2.1.

**Problem 2.12:** Compare the planar atom density of the {100}-type planes with the {111}-type planes in the FCC structure of copper that has a lattice parameter of 0.361 nm.

**Solution:**

For the {100} planes there are 2 atoms in the cube face that has an area of  $a^2$  thus the planar density is

$$\frac{2 \text{ atoms}}{a^2} = \frac{2 \text{ atoms}}{(0.363 \times 10^{-9} \text{ m})^2} = \frac{2 \text{ atoms}}{0.132 \times 10^{-18} \text{ m}^2} = 15.1 \times 10^{18} \frac{\text{atoms}}{\text{m}^2}$$

The {111} planes in the FCC crystal of copper form equilateral triangles that have sides that are the face diagonals of length  $2^{1/2}(a)$  where the lattice parameter is  $a$ , the height of the triangle is  $1/2$  of the cube diagonal that has a length  $3^{1/2}(a)$  or  $1/2[3^{1/2}(a)]$ . The area of the equilateral triangle formed by the {111} plane is

$$A = \frac{1}{2}(2^{1/2} \times (1/2)3^{1/2}) a^2 = 0.613 a^2 = 0.613(0.361 \times 10^{-9} \text{ m})^2 = 0.613(0.130 \times 10^{-18} \text{ m}^2) = 0.080 \times 10^{-18} \text{ m}^2$$

The number of atoms on this plane is  $1/2$  atom on the three face diagonals for  $3/2$  atoms, and  $1/6$  of an atom ( $60/360$ ) at each of the three  $60$  degree angles or  $3/6 = 1/2$  atom. The total number of atoms in the equilateral triangle is  $3/2 + 1/2 = 4/2 = 2$ . The atom density ( $n_a$ ) of the {111} planes is

$$n_a = 2 \text{ atoms} / 0.080 \times 10^{-18} \text{ m}^2 = 25 \times 10^{18} \text{ atoms/m}^2$$

The {111} type planes have the highest packing density in the FCC type crystals.



**Problem 2.13:** Draw the following directions in a cubic unit cell:  $[001]$ ,  $[00\bar{1}]$ ,  $[110]$ ,  $[111]$ ,  $[1\bar{1}1]$ ,  $[11\bar{2}]$ , and  $[1\bar{2}3]$ . Label each direction, and show the coordinates of where each direction intersects the boundary of the unit cell.

**Solution:**

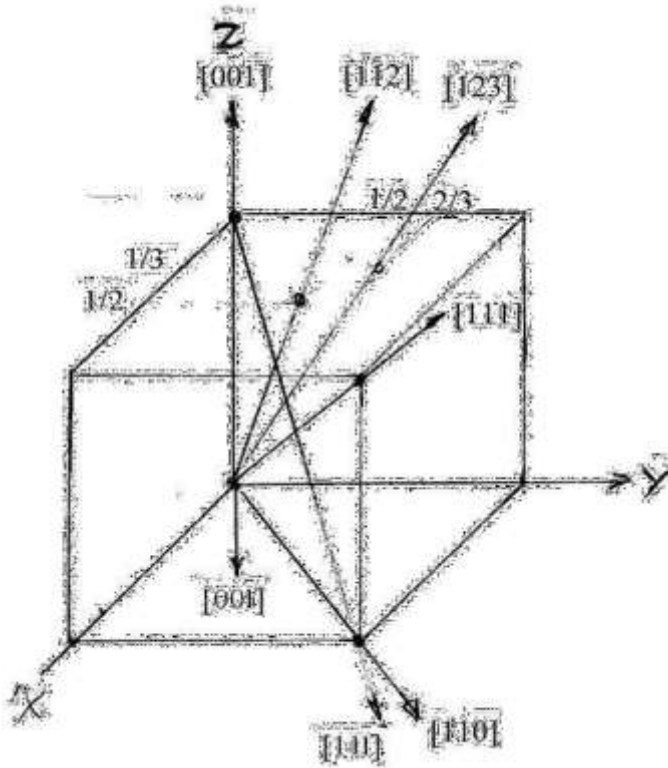

**Problem 2.14:** (a) Compare the linear atom density of the  $[100]$  and  $[111]$  directions in the BCC metal iron, with a lattice parameter of 0.286 nm. (b) Which is the most closely packed direction in the BCC structure? (c) What is the radius of an iron atom if it is assumed that the atoms touch along the most closely packed direction?

**Solution:**

The  $[100]$  direction is along the cube side. There is  $\frac{1}{2}$  atom at 0, 0, 0 and  $\frac{1}{2}$  atom at 1, 0, 0 for a total of 1 atom in a distance of 0.286 nm. The  $LAD$  is

$$LAD = \frac{1 \text{ atoms}}{.286 \text{ nm}} = 3.5 \frac{\text{atoms}}{\text{nm}}$$

$$LAD[100] = 3.5 \frac{\text{atoms}}{\text{nm}}$$

The [111] direction is along the body diagonal of the body centered cubic lattice. The body diagonal goes from the position 0, 0, 0 to the position 1, 1, 1. In the BCC structure body diagonal has  $\frac{1}{2}$  atom at 0, 0, 0 plus 1 atom at  $\frac{1}{2}, \frac{1}{2}, \frac{1}{2}$ , plus  $\frac{1}{2}$  atom at 1, 1, 1 for a total of 2 atoms.

The length of the body diagonal is  $0.286 \text{ nm} (\sqrt{3}) = 0.495 \text{ nm}$ . The linear atom density is then

$$LAD = \frac{2 \text{ atoms}}{0.495 \text{ nm}} = 4.03 \frac{\text{atoms}}{\text{nm}}$$

$$LAD[111] = 4.03 \frac{\text{atoms}}{\text{nm}}$$

If we checked the linear atom density in all directions of the body centered cubic metal crystal, we would find that the  $\langle 111 \rangle$  directions have the highest linear atom density.

(b) Along the body diagonal of the BCC crystal there are four atomic radii ( $4R$ ) in a distance of  $0.495 \text{ nm}$ .

$$4R = 0.495 \text{ nm}$$

$$R = 0.124 \text{ nm}$$

**Problem 2.15:** Pure iron at room temperature has the BCC structure; however, iron can also be found in the FCC structure at higher temperatures. Predict the lattice parameter of FCC iron if it did form at room temperature, assuming that atoms touch only along the most closely packed directions in both the FCC and BCC structures. The lattice parameter of BCC iron at room temperature is  $0.286 \text{ nm}$ .

**Solution:**

The shortest interatomic distance in the BCC structure is between a corner atom and the body centered atom. That is a length of  $\frac{a}{\sqrt{2}}$  [111]. In this length there are two atomic radii

$$\frac{0.286 \text{ nm}}{\sqrt{2}} = 2R = 0.248 \text{ nm} = 2R$$

For the FCC structure the shortest interatomic distance is  $\frac{a}{\sqrt{2}}$  [110] and this also is equal

to  $2R$  thus:

$$\frac{a}{\sqrt{2}} [110] = 2R = 0.248 \text{ nm} = \frac{a}{\sqrt{2}} [1^2 + 1^2 + 0]^{1/2} = \frac{a}{\sqrt{2}}$$

Solving for the lattice parameter  $a$

$$a = 0.248(\sqrt{2}) = 0.351 \text{ nm for iron in the FCC structure at room temperature.}$$

**Problem 2.16:** If sufficient force is applied to a crystal, it can be permanently deformed. Permanent deformation in metal crystals occurs due to atomic displacements on the planes that are most closely packed, and it happens in the most closely packed directions. Assume that a force is applied to a crystal of FCC copper that permanently stretches the crystal in the [001] direction. The (111) plane is one of the close-packed planes in FCC copper on which permanent deformation could occur.

- (a) What is the angle between the [001] direction and the normal to the (111) plane?
- (b) Atom displacements along which close-packed directions within the (111) plane could contribute to the permanent deformation of the crystal in the [001] direction?

**Solution:**

(a) The normal to the (111) plane is the [111] direction. The cosine of the angle  $\theta$  between [111] and [001] is given by the length of a side of the cube divided by the body diagonal.

$$\cos \theta = \frac{a}{\sqrt{3}a} = 0.577, \theta = 54.7^\circ$$

(b) The directions in the (111) that could contribute to deformation in the [001] are  $[01\bar{1}]$  and  $[\bar{1}01]$  as shown in the figure.

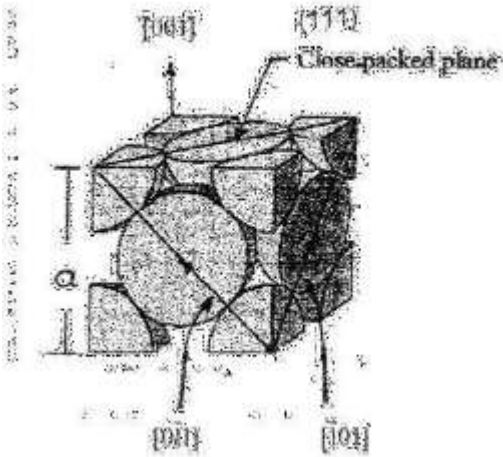

**Problem 2.17:** Permanent deformation in BCC crystals occurs on the most closely packed planes, and it happens in the most closely packed directions that are  $\{110\}$  planes and  $\langle 111 \rangle$  directions in the BCC crystal. Assume that a force is applied to a BCC crystal that permanently deforms it in the  $[001]$  direction. For permanent deformation that is on a  $(11)$  plane:

- What is the angle between the normal to the  $(011)$  plane and the  $[001]$  direction?
- Atomic displacements along what most closely packed directions could contribute to permanent deformation of the crystal in the  $[001]$  direction?

**Solution:**

(a) The normal to the  $(011)$  plane is in the  $[011]$  direction. The angle between the  $[011]$  and  $[001]$  directions is

$$\cos\theta = \frac{a}{a\sqrt{2}} = \frac{1}{\sqrt{2}} = 0.707$$

$$\theta = 45$$

(b) On the  $(011)$  plane the  $\langle 111 \rangle$  type directions that could contribute to deformation in the  $[001]$  direction are the  $\bar{1}\bar{1}1$  and the  $1\bar{1}1$ .

**Problem 2.18:** Briefly explain how a fiber made of oriented ultra-high-molecular-weight polyethylene can be much stronger than structural steel in tension, but perpendicular to the fiber axis, its hardness is much less than that of steel.

**Solution:**

In tension the force is pulling on the strong covalent carbon-carbon bonds in the long chain molecules oriented along the fiber axis. In a hardness test perpendicular to the fiber axis the indenter displaces the weak van der Waals bonds that hold different fibers together.

**Problem 2.19:** How many carbon and hydrogen atoms are there in the unit cell of polyethylene shown in Figure 2.21c, assuming that the density of crystalline polyethylene is  $0.996 \text{ g/cm}^3$ ?

**Solution:**

We can use the equation in Example problem 2.3 and write the density of polyethylene ( $\rho_{PE}$ ) is equal to:

$$\rho_{PE} = 0.996 \times 10^3 \frac{\text{kg}}{\text{m}^3} = \frac{n_{PE} M_{PE}}{N_A}$$

However in this case there are two atom types: carbon and hydrogen. There are always 2 hydrogen atoms for each carbon. Thus if  $x$  is the number of carbon atoms then  $2x$  is the number of hydrogen. The above equation can then be written as for molecules as:

$$\rho_{PE} = 0.996 \times 10^3 \frac{\text{kg}}{\text{m}^3} = \frac{(x \text{ C atoms})(M_C \frac{\text{kg}}{\text{mole}}) + (2x \text{ H atoms})(M_H \frac{\text{kg}}{\text{mole}})}{m^3 N_A (V_{PE} \text{ m}^3) N_A \text{ molecules / mole}}$$

$V_{PE}$  is the volume of the polyethylene unit cell, and  $x$  is the number of carbon atoms in the unit cell,  $M_C$  is the molar mass of carbon. Taking values from the periodic table and inserting Avagadro's number results in

$$0.996 \times 10^3 \frac{\text{kg}}{\text{m}^3} = \frac{(x \text{ C atoms})(12.01 \times 10^{-3} \text{kg/mole}) + (2x \text{ H atoms})(1.01 \times 10^{-3} \text{kg/mole})}{(0.741 \times 10^{-9} \text{ m})(0.494 \times 10^{-9} \text{ m})(0.255 \times 10^{-9} \text{ m})(6.02 \times 10^{23} \text{ atoms / mole})}$$

Multiplying out numbers results in

$$0.996 \times 10^3 \frac{\text{kg}}{\text{m}^3} = \frac{x(14.03 \times 10^{-3} \text{ kg})}{0.562 \times 10^{-27} \text{ m}^3} = x(24.96 \times 10^4) \frac{\text{kg}}{\text{m}^3} = x(249.6) \frac{\text{kg}}{\text{m}^3}$$

Solving for  $x$  results in  $x=4$ . The number of carbon atoms is four, and the number of hydrogen atoms is eight.

**Problem 2.20:** MgO is a high -temperature ceramic material that has mixed ionic and covalent bonding. Should MgO have the NaCl structure or the CsCl structure based upon ionic radii?

**Solution:**

From Appendix C the ionic radius of Mg is 0.066 nm and for oxygen it is 0.132 for a radius ratio of:

$$\frac{r_c}{r_a} = \frac{0.066 \text{ nm}}{0.132 \text{ nm}} = 0.5$$

From Figure 2.24 each O ion should be surrounded by six nearest neighbors. Thus MgO should have the NaCl structure.

**Problem 2.21:** Use a spreadsheet or write a short computer program to confirm the percent ionic and covalent character of the bonding in Table 2.3.

**Solution:**

Compound	energy 1	energy 2	delta(D)	delta sq	0.25Dsqr	minus F	% ionic
ZrO2	3.5	1.4	2.1	4.41	1.1025	-1.1025	0.66796
MgO	3.5	1.2	2.3	5.29	1.3225	-1.3225	0.733531
Al2O3	3.5	1.5	2	4	1	-1	0.63212
SiO2	3.5	1.8	1.7	2.89	0.7225	-0.7225	0.514463
Si3N4	3	1.8	1.2	1.44	0.36	-0.36	0.302324
SiC	2.5	1.8	0.7	0.49	0.1225	-0.1225	0.115294

**Problem 2.22:** The lattice parameter of CsCl is 0.4123 nm. Calculate the density of CsCl.

**Solution:**

CsCl is simple cubic, thus it has one lattice point (LP) per unit cell. The number of lattice points per unit volume is

$$n = \frac{1 \text{ LP}}{(0.4123 \times 10^{-9})^3 \text{ m}^3} = \frac{1 \text{ LP}}{(0.071 \times 10^{-27}) \text{ m}^3} = 14.27 \times 10^{27} \frac{\text{LP}}{\text{m}^3}$$

Each lattice point has two atoms associated with it one Cs and one Cl. The molar mass of Cs is 132.91 g/mole and for Cl it is 35.45 g/mole, thus the total molar weight per lattice point is 168.36 g/mole. Putting these values into the equation for the density.

$$\rho_{\text{CsCl}} = \frac{n_{\text{LP}} M_{\text{LP}}}{N_A} = 1.427 \times 10^{28} \frac{\text{LPs}}{\text{m}^3} \frac{\text{mole of LPs}}{6.02 \times 10^{23} \text{ LPs}} 168.36 \times 10^{-3} \frac{\text{kg}}{\text{mole of LPs}}$$

$$\rho_{\text{CsCl}} = 3.99 \times 10^3 \frac{\text{kg}}{\text{m}^3}$$

**Problem 2.23:** You are trying to identify a mineral that has been brought to your laboratory. The density is measured to be  $1.984 \times 10^3 \text{ kg/m}^3$ . From the density you think it might be KCl. From data available, you know the KCl has the same crystal structure as NaCl, but you cannot find the lattice parameter of KCl. Determine the lattice parameter of KCl from the density that you can then confirm with x-ray diffraction.

**Solution:**

If KCl has the NaCl structure it is face centered cubic with a Cl atom at 0, 0, 0 and a K atom at  $\frac{1}{2}, 0, 0$ .

There are four lattice points (LPs) in the KCl unit cell. The molar mass of K is 39.10 g/mole, and for Cl it is 35.45 g/mole, thus each lattice point has a molar mass of 74.55 g/mole.

From the density of KCl we can obtain the number of lattice points per unit volume and from that the lattice parameter.

$$\rho_{KCl} = 1.984 \times 10^3 \frac{\text{kg}}{\text{m}^3} = \frac{n_{LP} M_{LP}}{N_A}$$

Rearranging this equation and solving for the number of lattice points per unit volume ( $n_{LP}$ ).

$$n_{LP} = \frac{\rho_{KCl} N_A}{M_{LP}} = 1.984 \times 10^3 \frac{\text{kg}}{\text{m}^3} \frac{6.02 \times 10^{23} \text{ LPs}}{\text{mole of LPs}} \frac{\text{mole of LPs}}{74.55 \times 10^{-3} \text{ kg}} = 0.16 \times 10^{29} \frac{\text{LPs}}{\text{m}^3}$$

There are 4 lattice points per unit cell volume of  $a^3$  if this is KCl.

$$n_{LP} = 0.16 \times 10^{29} \frac{\text{LPs}}{\text{m}^3} = 4 \frac{\text{LPs}}{a^3}$$

$$\text{Solve for } a^3. \quad a^3 = \frac{4 \text{ LPs} \cdot \text{m}^3}{0.16 \times 10^{29} \text{ LPs}} = 24.97 \times 10^{-29} \text{ m}^3 = 249.7 \times 10^{-30} \text{ m}^3$$

Solve for the lattice parameter ( $a$ ).  $a = 6.30 \times 10^{-10} \text{ m} = 0.630 \text{ nm}$

**Problem 2.24:** An empirical interatomic pair potential for xenon atoms, in units of eV, and nm, has been determined to be

$$V(r) = \frac{12.6 \times 10^{-7}}{r^{12}} - \frac{31.8 \times 10^{-4}}{r^6}$$

The lattice parameter of FCC xenon is equal to 0.630 nm.

- Determine the equilibrium pair bonding energy.
- Determine the cohesive energy of a xenon crystal at 0 kelvin using only the nearest-neighbor interactions, and compare your result with the value in the periodic table. Comment on any observed difference.

**Solution:**

(a) From the lattice parameter ( $a$ ) of face centered cubic xenon, the equilibrium interatomic separation ( $r$ ) is equal to

$$r = \frac{a}{2^{1/2}} = \frac{0.630 \text{ nm}}{1.414} = 0.445 \text{ nm}$$



The interatomic separation is equal to two atomic radii. Substituting the interatomic separation of 0.445 nm into the interatomic potential for argon results in

$$V(r) = \frac{12.6 \times 10^{-7}}{(0.445)^{12}} - \frac{31.8 \times 10^{-4}}{(0.445)^6}$$

$$V(r) = \frac{12.6 \times 10^{-7}}{6.03 \times 10^{-5}} - \frac{31.8 \times 10^{-4}}{7.77 \times 10^{-3}} = 0.021 \text{ eV} - 0.041 \text{ eV} = -0.02 \text{ eV}$$

Experimentally the pair bond energy has been determined to be  $-0.02 \text{ eV}$  for excellent agreement.

(b) Considering only nearest neighbor interactions the cohesive energy per atom is

$$V_{coh}(r) \frac{\text{eV}}{\text{atom}} = \frac{C_N \text{ pair bonds}}{2 \text{ atom}} V_p(r) \frac{\text{eV}}{\text{pair bond}} = \frac{12 \text{ pair bonds}}{2 \text{ atom}} (-0.02) \frac{\text{eV}}{\text{pair bond}}$$

$$V_{coh}(r) = -0.12 \frac{\text{eV}}{\text{atom}}$$

The experimental value in the Periodic Table is  $-0.15 \text{ eV}$ . The difference is due to considering only nearest neighbor interactions.

**Problem 2.25:** Assume that an interionic pair potential between  $\text{K}^+$  and  $\text{Cl}^-$  ions can be approximated by Equation 2.15. Assume that the repulsive ion core interactions can be modeled with a power of  $m=12$ . Experimentally it has been determined that the energy to separate one pair of  $\text{K}^+$  and  $\text{Cl}^-$  ions is  $5.0 \text{ eV}$ , and that the equilibrium interionic separation is equal to  $0.266 \text{ nm}$ . Use this experimental data to determine the value of  $B$  for an ion pair. Use the SI system of units for this problem.

**Solution:**

First convert  $-5.0 \text{ eV}$  to  $-8.01 \times 10^{-19} \text{ J}$ . Equation 2.15 is

$$V_{ion}(r) = -\frac{(Ze)^2}{4\pi\epsilon_0 r} + \frac{B}{r^m}$$

$$-8.01 \times 10^{-19} \text{ J} = -\frac{(1.602 \times 10^{-19} \text{ C})^2}{4\pi(8.85 \times 10^{-12} \text{ F/m})(0.266 \times 10^{-9} \text{ m})} + \frac{B}{(0.266 \times 10^{-9} \text{ m})^{12}}$$

$$-8.01 \times 10^{-19} \text{ J} = -\frac{2.566 \times 10^{-38} \text{ C}^2}{0.2958 \times 10^{-19} \text{ F} (1 \times 10^{-7})(10^{-108}) \text{ m}^{12}} + \frac{B}{1 \times 10^{-115} \text{ m}^{12}}$$

$$B = 0.665 \times 10^{-19} \text{ J} (1 \times 10^{-115} \text{ m}^{12}) = 0.665 \times 10^{-134} \text{ J} \cdot \text{m}^{12}$$

**Problem 2.26:** Test the  $K^+$  and a  $Cl^-$  interionic potential that you developed for Problem 2.25 by determining the equilibrium interionic separation, and comparing this value to the experimental value of 0.266 nm.

**Solution:**

From Problem 2.25 the numerical form of the  $K^+$  and a  $Cl^-$  interionic potential is

$$V(r) = -\frac{(Ze)^2}{4\pi\epsilon_0 r} + \frac{B}{r^m} = -\frac{2.308 \times 10^{-28}}{r} + \frac{0.665 \times 10^{-134}}{r^{12}}$$

The interionic force is equal to  $F = (-1)\frac{2.308 \times 10^{-28}}{r^2} + (-12)\frac{0.665 \times 10^{-134}}{r^{13}}$

At the equilibrium interionic separation the interionic force is equal to zero, resulting in

$$\frac{2.308 \times 10^{-28}}{r^2} = \frac{7.98 \times 10^{-134}}{r^{13}}$$

$$\frac{r^{13}}{r^2} = r^{11} = \frac{7.98 \times 10^{-134}}{2.308 \times 10^{-28}} = 3.458 \times 10^{-106} \text{ m}^{11} = 34580 \times 10^{-110} \text{ m}^{11}$$

Solve for the equilibrium interionic separation.  $r_0 = 2.59 \times 10^{-10} \text{ m} = 0.259 \text{ nm}$  . The calculated interatomic separation is approximately 3 % low, this is quite good agreement.



