

**Solution Manual for Mechatronics Electronic Control Systems in  
Mechanical and Electrical Engineering 6th Edition Bolton  
1292076682 9781292076683**

**Link full download:  
Solution Manual:**

<https://testbankpack.com/p/solution-manual-for-mechatronics-electronic-control-systems-in-mechanical-and-electrical-engineering-6th-edition-bolton-1292076682-9781292076683/>

**TEST 2**

**Actuation**

For the following questions, you have four answer options A, B, C and D. Choose the correct answer from the answer options.

Questions 1, 2 and 3 concern the following symbol, which describes a directional control valve.

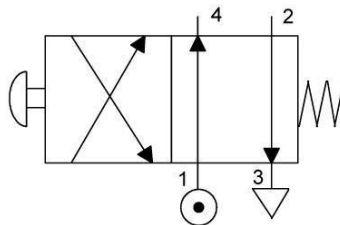

1. Decide whether each of these statements is TRUE (T) or FALSE (F). With the push-button not pressed:
  - (i) Pressure is applied to port 4.
  - (ii) Port 2 is vented.

A (i) T (ii) T  
B (i) T (ii) F  
C (i) F (ii) T  
D (i) F (ii) F
2. Decide whether each of these statements is TRUE (T) or FALSE (F). When the push-button is pressed:
  - (i) Pressure is applied to port 4.
  - (ii) Port 2 is vented.

Which option BEST describes the two statements?  
A (i) T (ii) T

B (i) T (ii) F

C (i) F (ii) T

D (i) F (ii) F

3. Decide whether each of these statements is TRUE (T) or FALSE (F). After pressing the push-button it is released, then:
- (i) Pressure is applied to port 2.
  - (ii) Port 4 is vented.

Which option BEST describes the two statements?

- A (i) T (ii) T
- B (i) T (ii) F
- C (i) F (ii) T
- D (i) F (ii) F

Questions 4 and 5 refer to the following figure, which shows a cylinder controlled by two pneumatic valves.

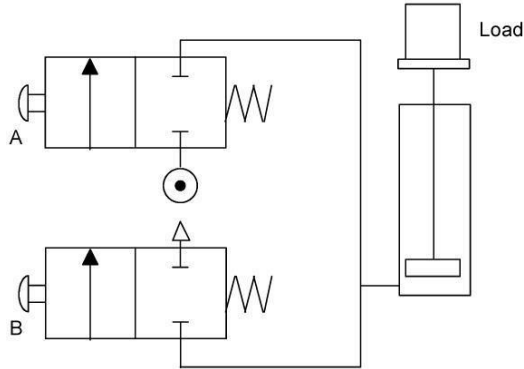

4. Decide whether each of these statements is TRUE (T) or FALSE (F).

- (i) When push-button A is pressed, the load is lifted.
- (ii) When push-button A is released, the load descends.

Which option BEST describes the two statements?

- A (i) T (ii) T
- B (i) T (ii) F
- C (i) F (ii) T
- D (i) F (ii) F

5. Decide whether each of these statements is TRUE (T) or FALSE (F).

- (i) When push-button B is pressed, the load is lifted.
- (ii) When push-button B is released, the load remains either lifted or descended. Which option BEST describes the two statements?

- A (i) T (ii) T
- B (i) T (ii) F
- C (i) F (ii) T
- D (i) F (ii) F

6. Decide whether each of these statements is TRUE (T) or FALSE (F). A process control valve with a quick-opening plug gives:
- (i) A change in flow rate that is proportional to the change in displacement of the valve stem.
  - (ii) A large change in the flow rate for a small initial movement of the valve stem.
- Which option BEST describes the two statements?
- A (i) T (ii) T
  - B (i) T (ii) F
  - C (i) F (ii) T
  - D (i) F (ii) F
7. For the pneumatic circuit given below, following the pressing of the start push-button the sequence is:

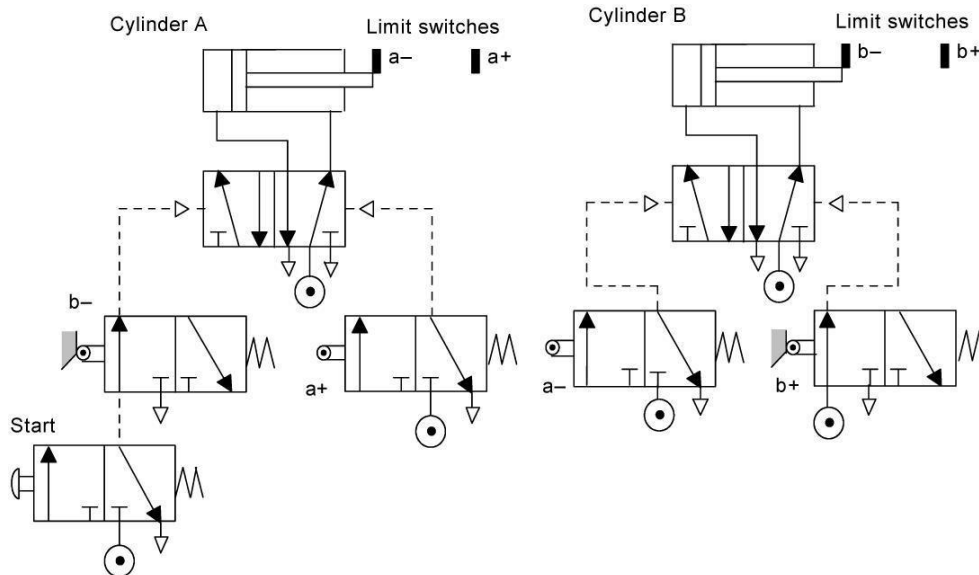

- A A+, B+, B-, A-
  - B A+, A-, B+, B-
  - C A+, B+, A-, B-
  - D A+, A-, B-, B+
8. Decide whether each of these statements is TRUE (T) or FALSE (F). Four links are connected as indicated in the following figure:

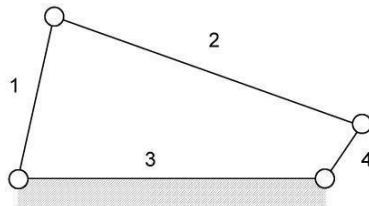

With the relative link lengths shown:

- (i) When link 4 rotates in a circular path, link 1 rotates in a circular path.
- (ii) If link 4 is made the same length as link 1 then when link 4 rotates, link 1 can only oscillate back-and-forth and not completely rotate.

Which option BEST describes the two statements?

- A (i) T (ii) T
- B (i) T (ii) F
- C (i) F (ii) T
- D (i) F (ii) F

9. The cam shown in the following figure rotates with a constant angular velocity.

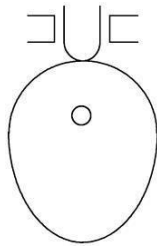

The displacement of the follower is best described by:

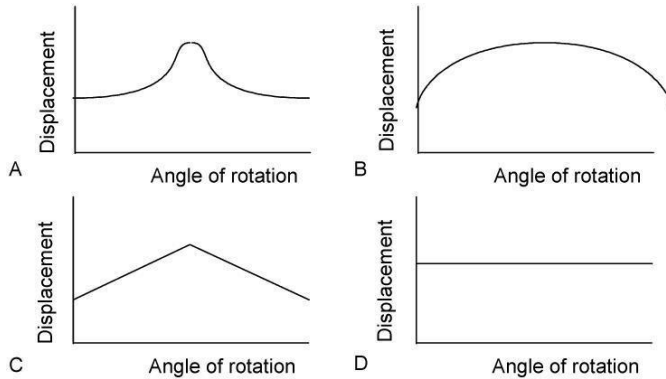

10. A ball bearing is required to withstand radial loads and axial loads. The optimum bearing from the following is:
- A Deep groove.
  - B Filling-slot.
  - C Angular contact.
  - D Self-aligning.

11. Decide whether each of these statements is TRUE (T) or FALSE

(F). For a thyristor:

- (i) When it is switched on and forward breakdown occurs, the thyristor resistance drops to a low value.
- (ii) The voltage at which a thyristor is switched on is determined by the current entering the gate.

Which option BEST describes the two statements?

- A (i) T (ii) T
- B (i) T (ii) F
- C (i) F (ii) T
- D (i) F (ii) F

12. Decide whether each of these statements is TRUE (T) or FALSE

(F). For a series wound DC motor:

- (i) The direction of rotation of its shaft can be reversed by reversing the direction of the current supplied to the motor.
- (ii) The speed of rotation of the motor shaft can be controlled by varying the size of the current supplied to the motor.

Which option BEST describes the two statements?

- A (i) T (ii) T
- B (i) T (ii) F
- C (i) F (ii) T
- D (i) F (ii) F

13. Decide whether each of these statements is TRUE (T) or FALSE

(F). For a shunt wound DC motor:

- (i) The direction of rotation of its shaft can be reversed by reversing the direction of the armature current.
- (ii) The speed of rotation of the motor shaft can be controlled by varying the size of the armature current.

Which option BEST describes the two statements?

- A (i) T (ii) T
- B (i) T (ii) F
- C (i) F (ii) T
- D (i) F (ii) F

14. Decide whether each of these statements is TRUE (T) or FALSE (F).

The H-circuit shown below is used to control the current supplied to a DC motor.

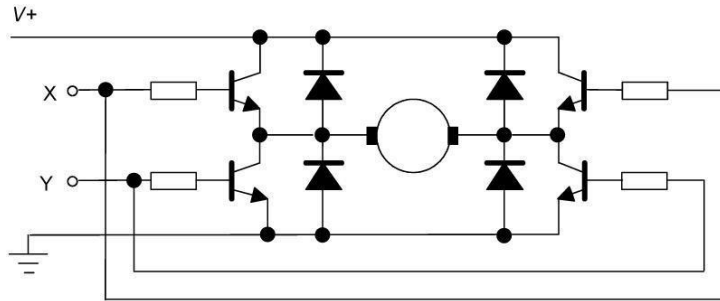

- (i) For the motor to rotate, we must have both X and Y high.
- (ii) To reverse the motor, we must have both X and Y low. Which option BEST describes the two statements?

- A (i) T (ii) T
- B (i) T (ii) F
- C (i) F (ii) T
- D (i) F (ii) F

15. Decide whether each of these statements is TRUE (T) or FALSE (F).

A stepper motor is specified as having a step angle of  $6^\circ$ . This means that:

- (i) Each pulse input to the motor rotates the motor shaft by  $6^\circ$ .
- (ii) An input of 300 pulses per second will cause it to rotate at 5 rev/s. Which option BEST describes the two statements?

- A (i) T (ii) T
- B (i) T (ii) F
- C (i) F (ii) T
- D (i) F (ii) F



16. Decide whether each of these statements is TRUE (T) or FALSE (F). The

figure below shows the unipolar connection for a stepper motor.

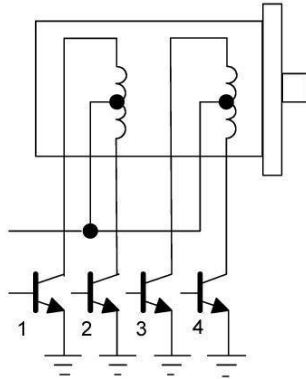

The motor will:

- (i) Rotate through one step when each transistor, 1, 2, 3 and 4, is switched on in turn, otherwise being off.
- (ii) Reverse its direction of rotation when the transistors are switched in the sequence 4, 3, 2 and 1, otherwise being off.

Which option BEST describes the two statements?

- A (i) T (ii) T
- B (i) T (ii) F
- C (i) F (ii) T
- D (i) F (ii) F