

Graphical Approach to College Algebra 6th Edition Hornsby Lial Rockswold 0321920309 9780321920300

Solution Manual:

<https://testbankpack.com/p/solution-manual-for-graphical-approach-to-college-algebra-6th-edition-hornsby-0321920309-9780321920300/>

Test Bank: <https://testbankpack.com/p/test-bank-for-graphical-approach-to-college-algebra-6th-edition-hornsby-0321920309-9780321920300/>

MULTIPLE CHOICE. Choose the one alternative that best completes the statement or answers the question.

Determine the intervals of the domain over which the function is continuous.

1)

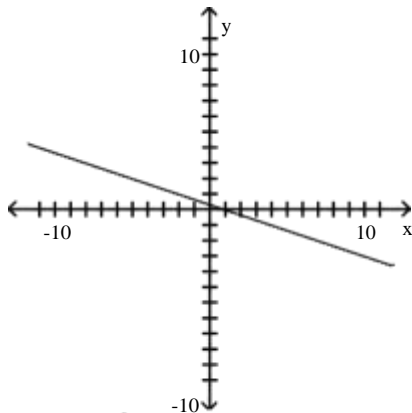

[)
A) $1, \infty$

B) $(-\infty, \infty)$

C) $(-\infty, 1]$

D) $[0, \infty)$

Answer: B

2)

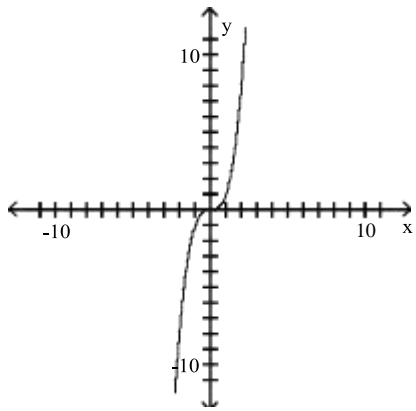

- A) $(0, \infty)$ B) $(-\infty, \infty)$ C) $(-\infty, 0]$ D) $[0, \infty)$
Answer: B

3)

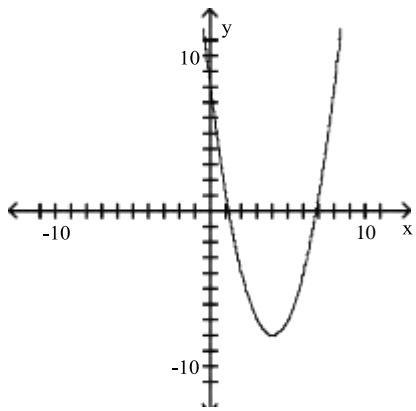

- A) $(-\infty, \infty)$ B) $(-\infty, 0); (0, \infty)$ C) $(-\infty, 0)$ D) $(0, \infty)$
Answer: A

4)

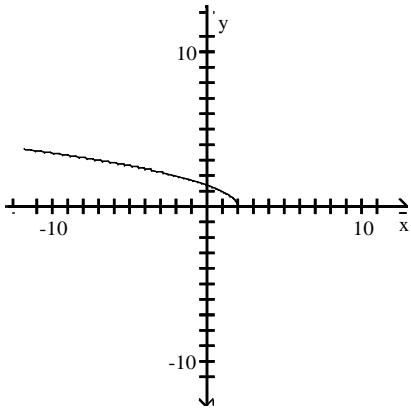

A) $(-\infty, \infty)$

B) $(-\infty, 2]$

C) $(-\infty, 2); (2, \infty)$

D) $(2, \infty)$

Answer: B

5)

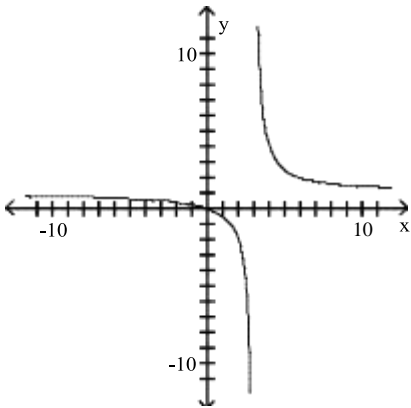

A) $(-\infty, 3); (3, \infty)$

B) $(-\infty, \infty)$

C) $(0, \infty)$

D) $(-\infty, -3); (-3, \infty)$

Answer: A

6)

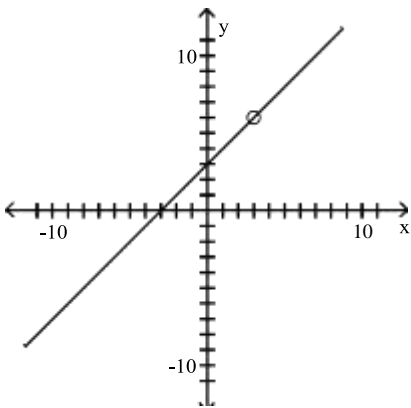

A) $(-\infty, -3); (-3, \infty)$

B) $(-\infty, \infty)$

C) $(-\infty, 3); (3, \infty)$

D) $(-\infty, 6); (6, \infty)$

Answer: C

7)

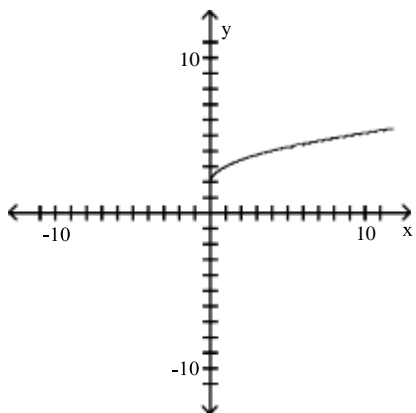

A) $[0, \infty)$

B) $[0, 2)$

C) $[-2, \infty)$

D) $[2, \infty)$

Answer: A

8)

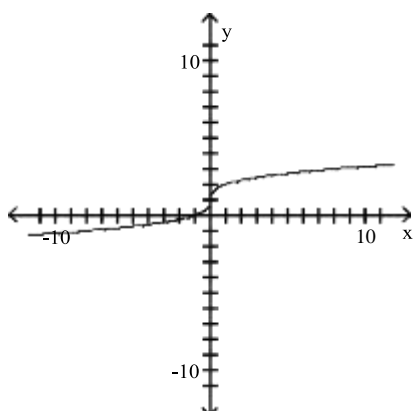

A) $(1, \infty)$

B) $(0, 1)$

C) $(0, \infty)$

D) $(-\infty, \infty)$

Answer: D

Determine the intervals on which the function is increasing, decreasing, and constant.

9)

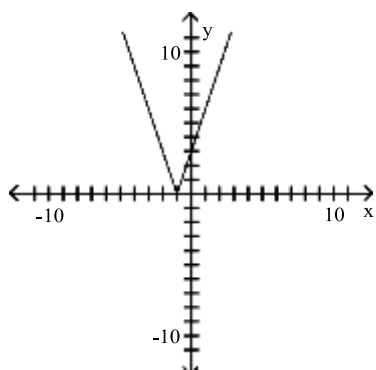

A) Increasing on $(-\infty, -1)$; Decreasing on $(-1, \infty)$

B) Increasing on $(-1, \infty)$; Decreasing on $(-\infty, -1)$

C) Increasing on $(-\infty, 1)$; Decreasing on $(1, \infty)$

D) Increasing on $(1, \infty)$; Decreasing on $(-\infty, 1)$

Answer: B

10)

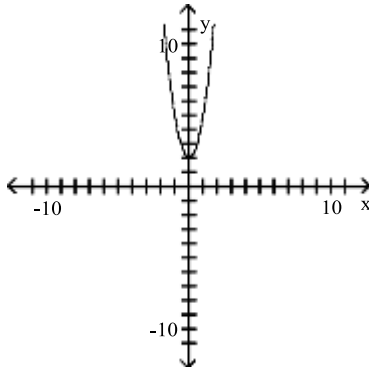

- A) Increasing on $(-\infty, 0)$; Decreasing on $(0, \infty)$
- C) Increasing on $(-\infty, 0)$; Decreasing on $(-\infty, 0)$

Answer: B

- B) Increasing on $(0, \infty)$; Decreasing on $(-\infty, 0)$
- D) Increasing on $(\infty, 0)$; Decreasing on $(0, -\infty)$

11)

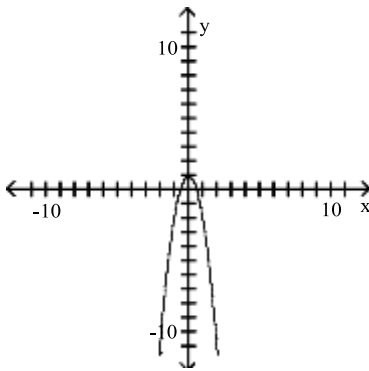

- A) Increasing on $(-\infty, 0)$; Decreasing on $(-\infty, 0)$
- C) Increasing on $(-\infty, 0)$; Decreasing on $(0, \infty)$

Answer: C

- B) Increasing on $(\infty, 0)$; Decreasing on $(0, -\infty)$
- D) Increasing on $(0, \infty)$; Decreasing on $(-\infty, 0)$

12)

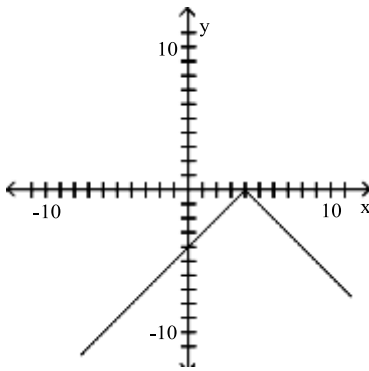

- A) Increasing on $(-\infty, 4)$; Decreasing on $(4, \infty)$
- C) Increasing on $(4, \infty)$; Decreasing on $(-\infty, 4)$

Answer: A

- B) Increasing on $(-\infty, 4)$; Decreasing on $(-\infty, 4)$
- D) Increasing on $(4, \infty)$; Decreasing on $(4, \infty)$

13)

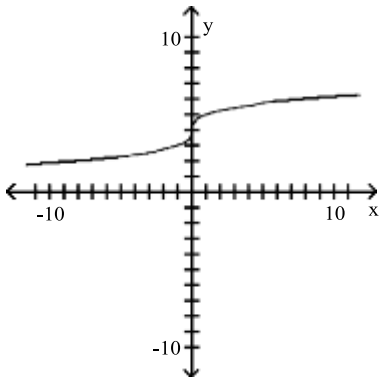

A) Decreasing on $(-\infty, \infty)$

C) Increasing on $(0, \infty)$; Decreasing on $(-\infty, 0)$

B) Increasing on $(-\infty, 0)$; Decreasing on $(0, \infty)$

D) Increasing on $(-\infty, \infty)$

Answer: D

14)

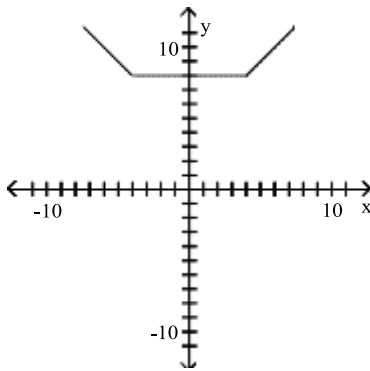

A) Increasing on $(-\infty, 4)$; Decreasing on $(-4, \infty)$; Constant on $(4, \infty)$

B) Increasing on $(4, \infty)$; Decreasing on $(-4, \infty)$; Constant on $(-4, 4)$

C) Increasing on $(-\infty, 4)$; Decreasing on $(-\infty, -4)$; Constant on $(4, \infty)$

D) Increasing on $(4, \infty)$; Decreasing on $(-\infty, -4)$; Constant on $(-4, 4)$

Answer: D

15)

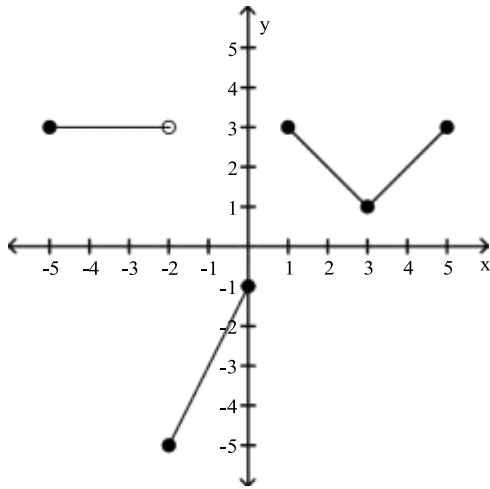

- A) Increasing on $(-2, 0)$ and $(3, 4)$; Decreasing on $(-5, -2)$ and $(1, 3)$
- B) Increasing on $(1, 3)$; Decreasing on $(-2, 0)$ and $(3, 5)$; Constant on $(2, 5)$
- C) Increasing on $(-1, 0)$ and $(3, 5)$; Decreasing on $(0, 3)$; Constant on $(-5, -3)$
- D) Increasing on $(-2, 0)$ and $(3, 5)$; Decreasing on $(1, 3)$; Constant on $(-5, -2)$

Answer: D

16)

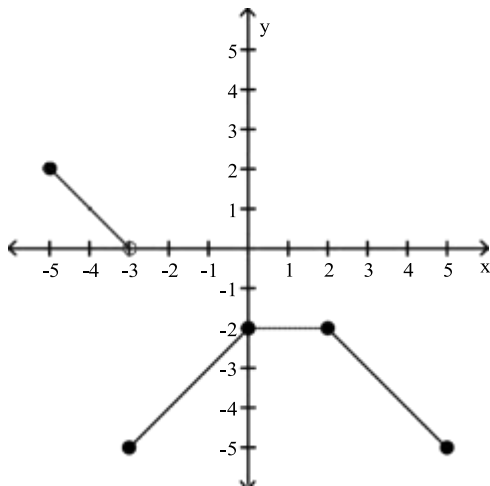

- A) Increasing on $(-3, 1)$; Decreasing on $(-5, -3)$ and $(0, 5)$; Constant on $(1, 2)$
- B) Increasing on $(-3, 0)$; Decreasing on $(-5, -3)$ and $(2, 5)$; Constant on $(0, 2)$
- C) Increasing on $(-3, -1)$; Decreasing on $(-5, -2)$ and $(2, 4)$; Constant on $(-1, 2)$
- D) Increasing on $(-5, -3)$ and $(2, 5)$; Decreasing on $(-3, 0)$; Constant on $(0, 2)$

Answer: B

Find the domain and the range for the function.

17)

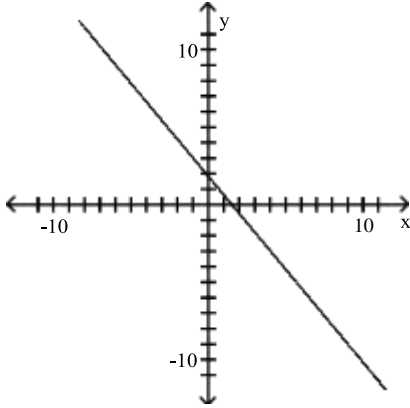

A) $D: (-\infty, \infty), R: (-\infty, \infty)$

C) $D: \left[\frac{3}{2}, \infty\right), R: [0, \infty)$

B) $D: \left[\frac{3}{2}, \infty\right), R: (-\infty, 0]$

D) $D: [0, \infty), R: \left[-\frac{9}{5}, \infty\right)$

Answer: A

18)

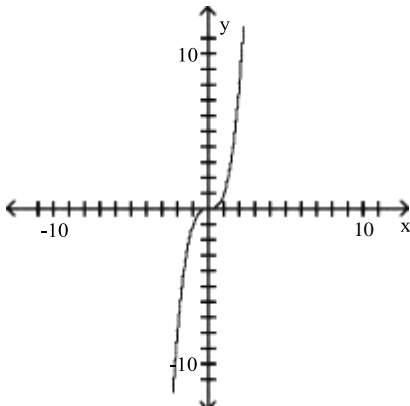

A) $D: (-\infty, 0], R: (-\infty, 0]$

C) $D: (0, \infty), R: (0, \infty)$

B) $D: [0, \infty), R: [0, \infty)$

D) $D: (-\infty, \infty), R: (-\infty, \infty)$

Answer: D

19)

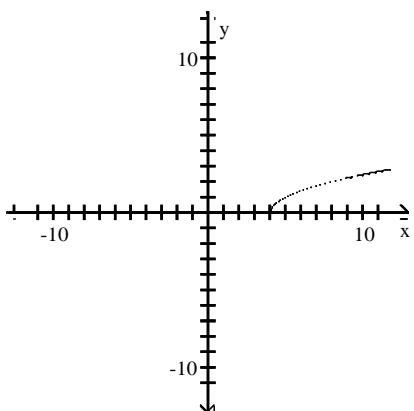

A) D: $[0, \infty)$, R: $(-\infty, 0]$

B) D: $(0, \infty)$, R: $(-\infty, 0)$

C) D: $[4, \infty)$, R: $[0, \infty)$

D) D: $(4, \infty)$, R: $[0, \infty)$

Answer: C

20)

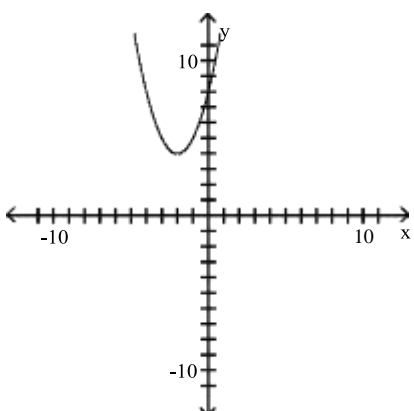

A) D: $(-\infty, 0)$, R: $(-\infty, 0)$

C) D: $(-\infty, \infty)$, R: $[4, \infty)$

B) D: $(-\infty, \infty)$, R: $(-\infty, \infty)$

D) D: $(0, \infty)$, R: $(-\infty, 0]$

Answer: C

21)

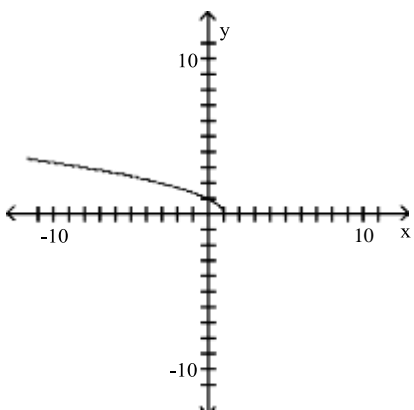

A) D: $(-\infty, \infty)$, R: $[0, \infty)$

B) D: $[0, \infty)$, R: $(-\infty, 1]$

C) D: $(-\infty, 1]$, R: $[0, \infty)$

D) D: $(-\infty, 1]$, R: $[1, \infty)$

Answer: C

22)

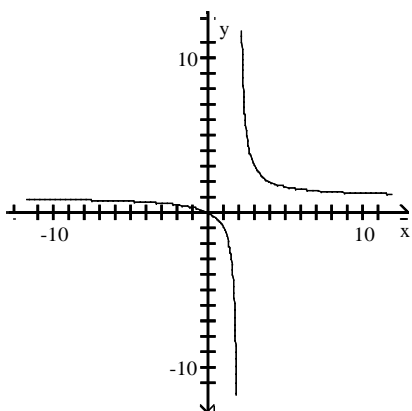

A) $D: (-\infty, -2) \cup (-2, \infty), R: (-\infty, \infty)$

C) $D: (-\infty, \infty), R: (-\infty, \infty)$

Answer: D

B) $D: (0, \infty), R: (1, \infty)$

D) $D: (-\infty, 2) \cup (2, \infty), R: (-\infty, 1) \cup (1, \infty)$

23)

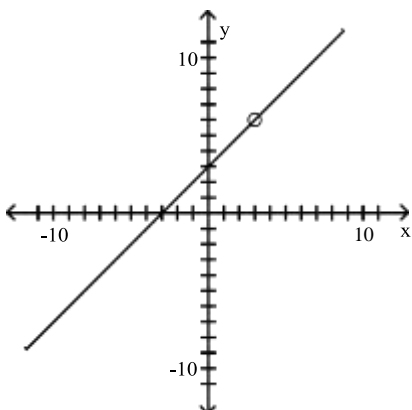

A) $D: (-\infty, -3) \cup (-3, \infty), R: (-\infty, -6) \cup (-6, \infty)$

C) $D: (-\infty, 6) \cup (6, \infty), R: (-\infty, 3) \cup (3, \infty)$

Answer: D

B) $D: (-\infty, \infty), R: (-\infty, \infty)$

D) $D: (-\infty, 3) \cup (3, \infty), R: (-\infty, 6) \cup (6, \infty)$

24)

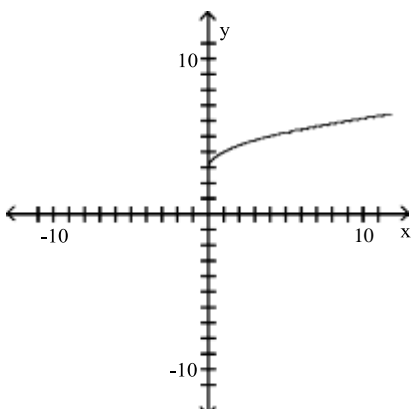

A) $D: [0, \infty), R: [0, \infty)$

C) $D: [0, \infty), R: [3, \infty)$

Answer: C

B) $D: [3, \infty), R: [0, \infty)$

D) $D: [-3, \infty), R: (-\infty, 0]$

25)

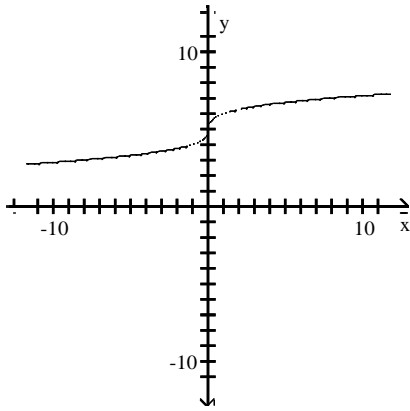

A) D: $(-\infty, \infty)$, R: $(-\infty, \infty)$

C) D: $(0, \infty)$, R: $[0, \infty)$

B) D: $(4, \infty)$, R: $[0, \infty)$

D) D: $(5, \infty)$, R: $(-\infty, 0]$

Answer: A

Determine if the function is increasing or decreasing over the interval indicated.

26) $f(x) = 7x - 5$; $(-\infty, \infty)$

A) Increasing

B) Decreasing

Answer: A

27) $f(x) = \frac{1}{4}x^2 - \frac{1}{2}x$; $(1, \infty)$

A) Increasing

B) Decreasing

Answer: A

28) $f(x) = x^2 - 2x + 1$; $(1, \infty)$

A) Increasing

B) Decreasing

Answer: A

29) $f(x) = (x^2 - 9)^2$; $(3, \infty)$

A) Increasing

B) Decreasing

Answer: A

30) $f(x) = \frac{1}{x^2 + 1}$; $(-\infty, 0)$

A) Increasing

B) Decreasing

Answer: A

31) $f(x) = \sqrt{4 - x}$; $(-\infty, 4)$

A) Increasing

B) Decreasing

Answer: B

32) $f(x) = |x - 8|$; $(-\infty, 8)$

A) Increasing

B) Decreasing

Answer: B

33) $f(x) = \frac{1}{x^2} + 7; (0, \infty)$

A) Increasing

B) Decreasing

Answer: B

34) $f(x) = -\sqrt{x+3}; (-3, \infty)$

A) Increasing

B) Decreasing

Answer: B

Determine if the graph is symmetric with respect to the x-axis, y-axis, or origin.

35)

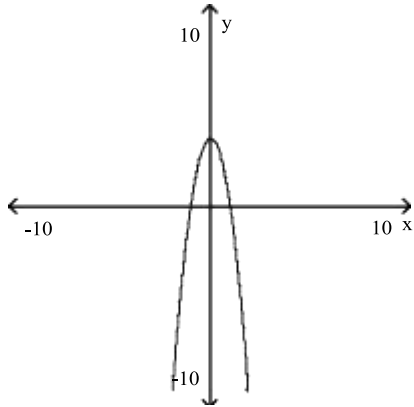

A) Origin

B) y-axis

C) y-axis, origin

D) x-axis, origin

Answer: B

36)

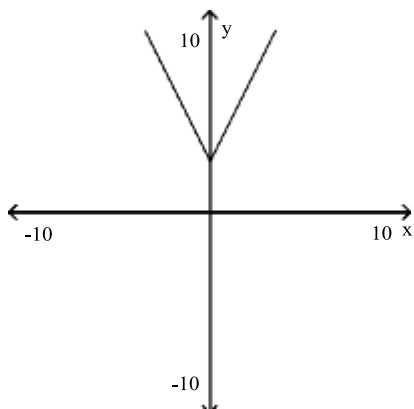

A) x-axis

B) x-axis, origin

C) y-axis, origin

D) y-axis

Answer: D

37)

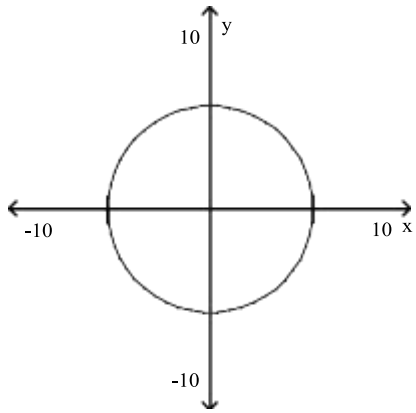

A) x-axis

C) x-axis, y-axis, origin

B) Origin

D) x-axis, origin

Answer: C

38)

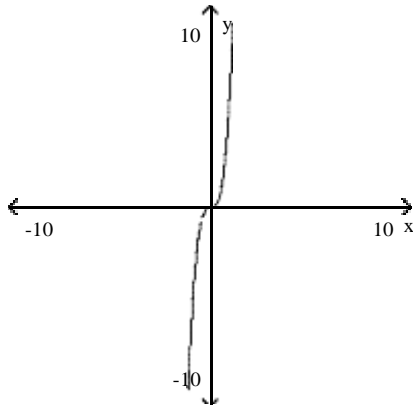

A) Origin

B) x-axis, origin

C) x-axis

D) y-axis

Answer: A

39)

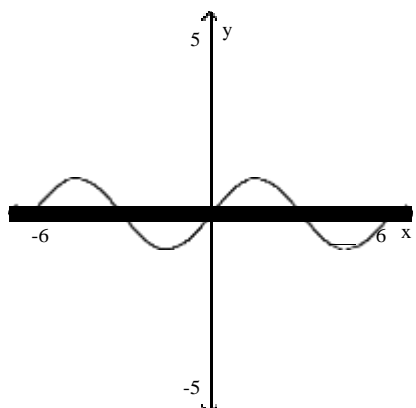

A) y-axis

B) Origin

C) x-axis

D) No symmetry

Answer: B

Based on the ordered pairs seen in the pair of tables, make a conjecture as to whether the function defined in Y_1 is even, odd, or neither even nor odd.

40)

X	Y_1	
0	0	
1	-3	
2	-6	
3	-9	
4	-12	
5	-15	
6	-18	
$X = 0$		

X	Y_1	
-6	18	
-5	15	
-4	12	
-3	9	
-2	6	
-1	3	
0	0	
$X = -6$		

A) Neither even nor odd

B) Odd

C) Even

Answer: B

41)

X	Y_1	
0	0	
1	1	
2	16	
3	81	
4	256	
5	625	
6	1296	
$X = 0$		

X	Y_1	
-6	1296	
-5	625	
-4	256	
-3	81	
-2	16	
-1	1	
0	0	
$X = -6$		

A) Odd

B) Even

C) Neither even nor odd

Answer: B

42)

X	Y_1	
0	0	
1	-1	
2	12	
3	75	
4	248	
5	615	
6	1284	
$X = 0$		

X	Y_1	
-6	1308	
-5	635	
-4	264	
-3	87	
-2	20	
-1	3	
0	0	
$X = -6$		

A) Even

B) Odd

C) Neither even nor odd

Answer: C

43)

X	Y ₁	
0	0	
1	1	
2	4	
3	9	
4	16	
5	25	
6	36	
X = 0		

X	Y ₁	
-6	36	
-5	25	
-4	16	
-3	9	
-2	4	
-1	1	
0	0	
X = -6		

A) Neither even nor odd

B) Odd

C) Even

Answer: C

44)

X	Y ₁	
0	-3	
1	-2	
2	1	
3	6	
4	13	
5	22	
6	33	
X = 0		

X	Y ₁	
-6	33	
-5	22	
-4	13	
-3	6	
-2	1	
-1	-2	
0	-3	
X = -6		

A) Odd

B) Even

C) Neither even nor odd

Answer: B

45)

X	Y ₁	
0	-4	
1	-3	
2	4	
3	23	
4	60	
5	121	
6	212	
X = 0		

X	Y ₁	
-6	-220	
-5	-129	
-4	-68	
-3	-31	
-2	-12	
-1	-5	
0	-4	
X = -6		

A) Odd

B) Neither even nor odd

C) Even

Answer: B

46)

X	Y ₁	
0	2	
1	2	
2	4	
3	8	
4	14	
5	22	
6	32	
X = 0		

X	Y ₁	
-6	44	
-5	32	
-4	22	
-3	14	
-2	8	
-1	4	
0	2	
X = -6		

A) Odd

B) Even

C) Neither even nor odd

Answer: C

47)

X	Y ₁	
0	0	
1	4	
2	8	
3	12	
4	16	
5	20	
6	24	
X = 0		

X	Y ₁	
-6	-24	
-5	-20	
-4	-16	
-3	-12	
-2	-8	
-1	-4	
0	0	
X = -6		

A) Neither even nor odd

B) Odd

C) Even

Answer: B

48)

X	Y ₁	
0	0	
1	-2	
2	-8	
3	-18	
4	-32	
5	-50	
6	-72	
X = 0		

X	Y ₁	
-6	-72	
-5	-50	
-4	-32	
-3	-18	
-2	-8	
-1	-2	
0	0	
X = -6		

A) Odd

B) Even

C) Neither even nor odd

Answer: B

49)

X	Y ₁	
0	0	
1	2	
2	6	
3	12	
4	20	
5	30	
6	40	
X = 0		

X	Y ₁	
-6	30	
-5	20	
-4	12	
-3	6	
-2	2	
-1	0	
0	0	
X = -6		

A) Odd

B) Even

C) Neither even nor odd

Answer: C

Determine whether the function is even, odd, or neither.

50) $f(x) = 5x^2 - 2$

A) Even

B) Odd

C) Neither

Answer: A

51) $f(x) = (x + 5)(x + 2)$

A) Even

B) Odd

C) Neither

Answer: C

52) $f(x) = -6x^3 + 6x$

A) Even

B) Odd

C) Neither

Answer: B

53) $f(x) = 3x^5 + 3x^3$

A) Even

B) Odd

C) Neither

Answer: B

54) $f(x) = 0.94x^2 + |x| + 6$

A) Even

B) Odd

C) Neither

Answer: A

55) $f(x) = 8x^4 - 2x + 9$

A) Even

B) Odd

C) Neither

Answer: C

56) $f(x) = |x^2 + x|$

A) Even

B) Odd

C) Neither

Answer: C

57) $f(x) = x^3 - \frac{1}{x}$

A) Even

B) Odd

C) Neither

Answer: B

Determine whether the graph of the given function is symmetric with respect to the y-axis, symmetric with respect to the origin, or neither.

58) $f(x) = -4x^2 + 1$

A) y-axis

B) Origin

C) Neither

Answer: A

59) $f(x) = |2x| + 4$

A) y-axis

B) Origin

C) Neither

Answer: A

60) $f(x) = 5x^3$

A) y-axis

B) Origin

C) Neither

Answer: B

61) $f(x) = 2x^2 + 4$

A) y-axis

B) Origin

C) Neither

Answer: A

62) $f(x) = -6x^3 + 2x$

A) y-axis

B) Origin

C) Neither

Answer: B

63) $f(x) = -5x^5 - 2x^3$

A) y-axis

B) Origin

C) Neither

Answer: B

64) $f(x) = -0.03x^2 + |x| + 3$

A) y-axis

B) Origin

C) Neither

Answer: A

65) $f(x) = 9x^4 + 6x + 4$

A) y-axis

B) Origin

C) Neither

Answer: C

66) $f(x) = x + \frac{1}{x^6}$

A) y-axis

B) Origin

C) Neither

Answer: C

Provide an appropriate response.

67) True or False: The function $y = \frac{x^2 - 7^2}{x - 7}$ is not continuous at $x = 7$.

A) True

B) False

Answer: A

68) Sketch the graph of $f(x) = -x^2$. At which of these points is the function increasing?

- A) 4 B) 0 C) -2 D) 2

Answer: C

69) True or False: A continuous function may be drawn without lifting the pencil from the paper.

- A) True B) False

Answer: A

70) What symmetry does the graph of $y = f(x)$ exhibit?

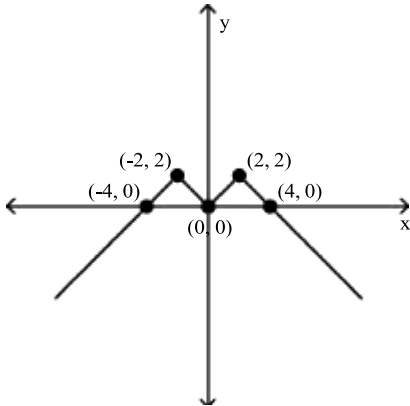

- A) Origin B) x-axis C) y-axis D) No symmetry

Answer: C

71) What symmetry does the graph of $y = f(x)$ exhibit?

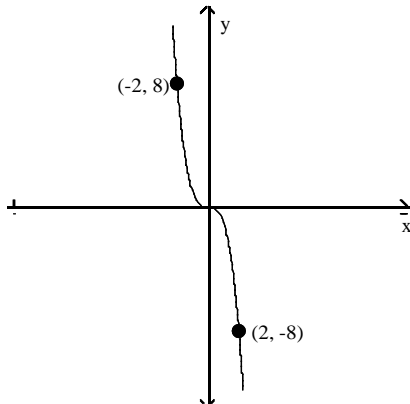

- A) x-axis B) y-axis C) Origin D) No symmetry

Answer: C

72) Complete the table if f is an even function.

x	-4	-2	-1	1	2	4
$f(x)$	8	-6	1			

A)

x	-4	-2	-1	1	2	4
$f(x)$	8	-6	1	1	-6	8

C)

x	-4	-2	-1	1	2	4
$f(x)$	8	-6	1	-8	6	-1

Answer: A

B)

x	-4	-2	-1	1	2	4
$f(x)$	8	-6	1	8	-6	1

D)

x	-4	-2	-1	1	2	4
$f(x)$	8	-6	1	-1	6	-8

SHORT ANSWER. Write the word or phrase that best completes each statement or answers the question.

73) Complete the right half of the graph of $y = f(x)$ for each of the following conditions:

(i) f is odd.

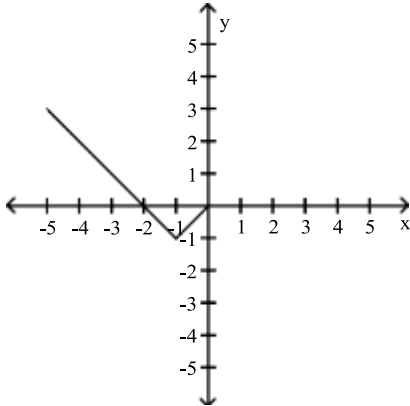

(ii) f is even.

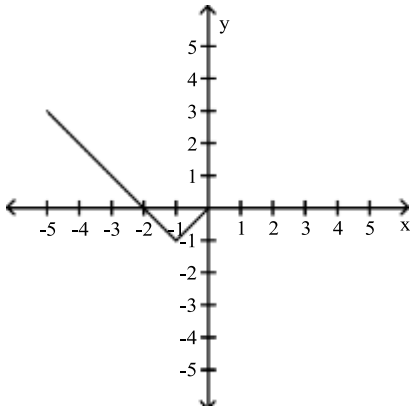

Answer: (i) f is odd.

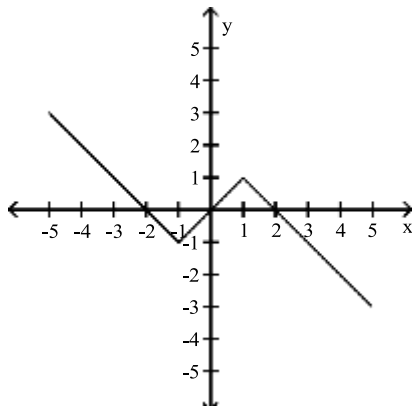

(ii) f is even.

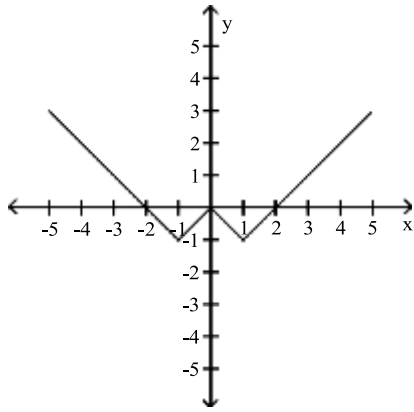

MULTIPLE CHOICE. Choose the one alternative that best completes the statement or answers the question.

Write an equation that results in the indicated translation.

74) The squaring function, shifted 8 units downward

A) $y = \frac{x^2}{8}$

B) $y = 8x^2$

C) $y = x^2 + 8$

D) $y = x^2 - 8$

Answer: D

75) The absolute value function, shifted 7 units to the right

A) $y = |x| - 7$

B) $y = |x - 7|$

C) $y = |x| + 7$

D) $y = |x + 7|$

Answer: B

76) The absolute value function, shifted 7 units upward

A) $y = |x - 7|$

B) $y = |x| - 7$

C) $y = |x| + 7$

D) $y = |x + 7|$

Answer: C

77) The square root function, shifted 9 units to the right

A) $y = \sqrt{x} + 9$

B) $y = \sqrt{x - 9}$

C) $y = \sqrt{x} - 9$

D) $y = \sqrt{x - 9}$

Answer: D

78) The square root function, shifted 7 units to the left

A) $y = \sqrt{x + 7}$

B) $y = \sqrt{x - 7}$

C) $y = \sqrt{x} - 7$

D) $y = \sqrt{x} + 7$

Answer: A

79) The square root function, shifted 6 units upward

A) $y = \sqrt{x} - 6$

B) $y = \sqrt{x - 6}$

C) $y = \sqrt{x + 6}$

D) $y = \sqrt{x} + 6$

Answer: D

80) The square root function, shifted 7 units downward

A) $y = \sqrt{x - 7}$

B) $y = \sqrt{x} - 7$

C) $y = \sqrt{x} + 7$

D) $y = \sqrt{x + 7}$

Answer: B

Use translations of one of the basic functions to sketch a graph of $y = f(x)$ by hand.

81) $y = x^2 - 4$

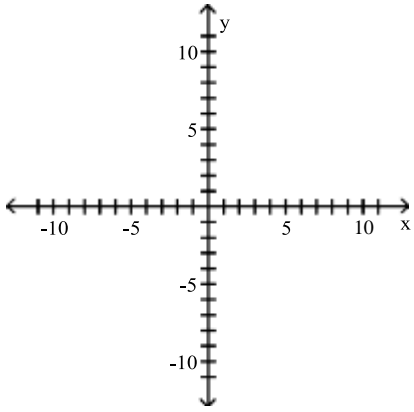

A)

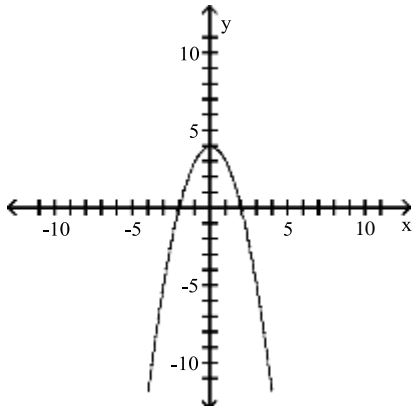

B)

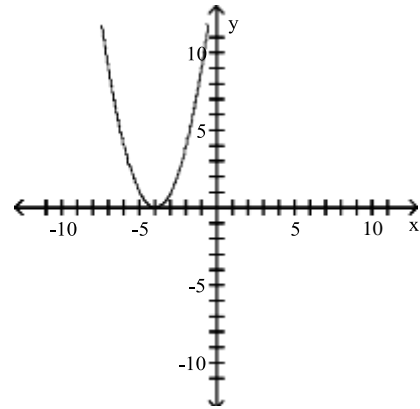

C)

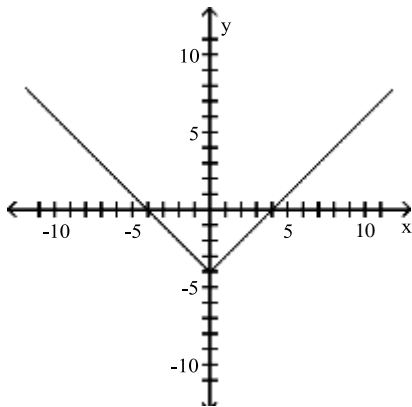

D)

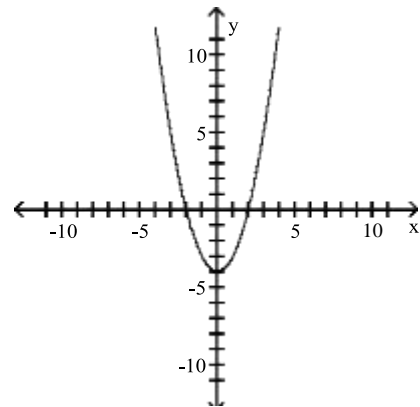

Answer: D

82) $y = |x - 6|$

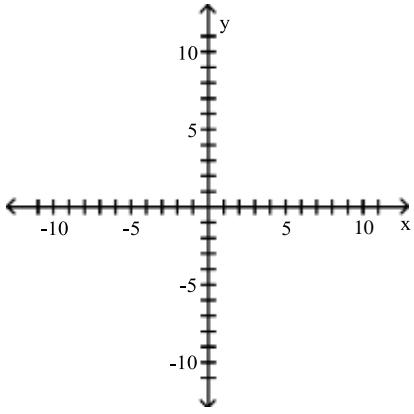

A)

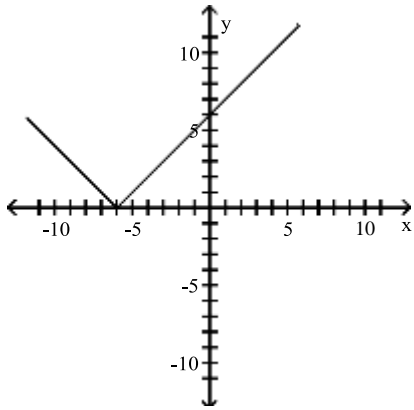

B)

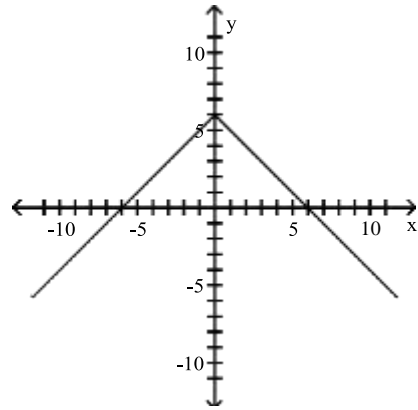

C)

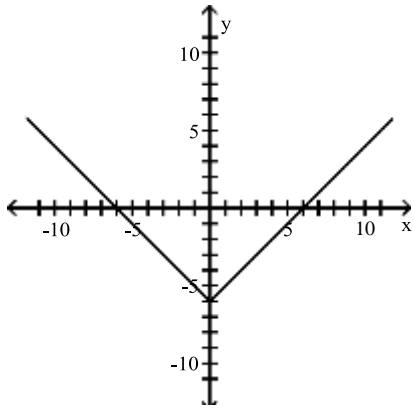

D)

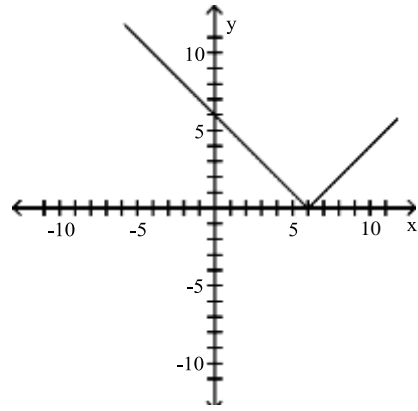

Answer: D

83) $y = x^3 - 4$

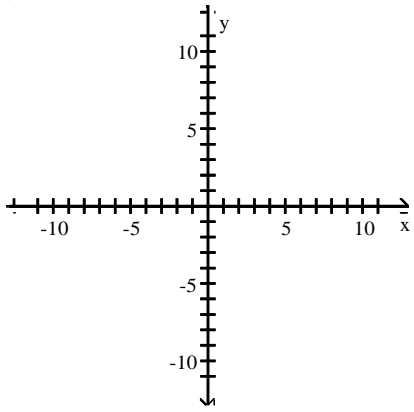

A)

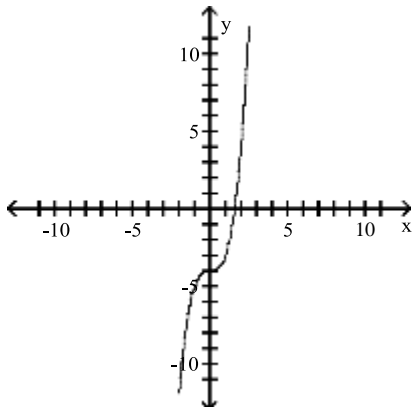

B)

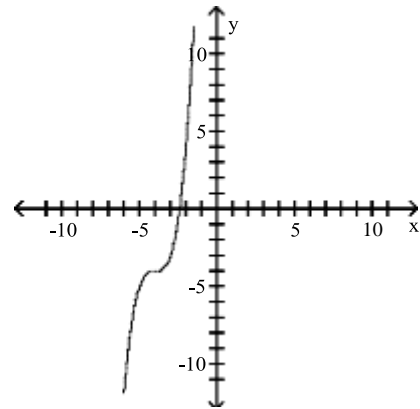

C)

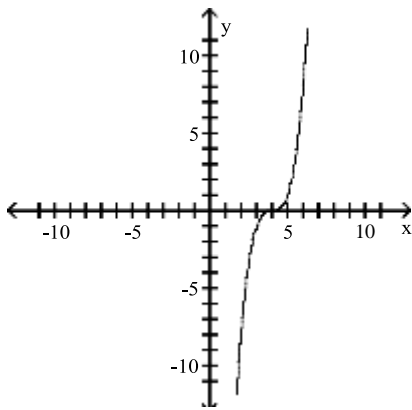

D)

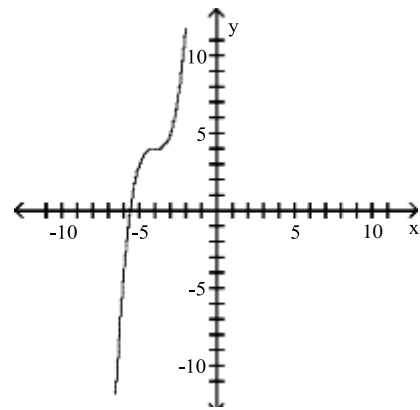

Answer: A

84) $y = (x + 3)^3$

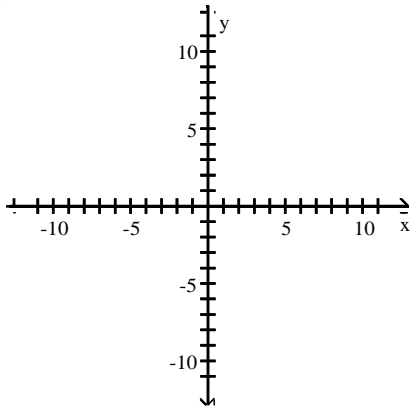

A)

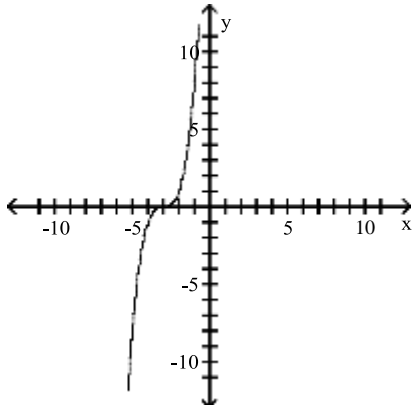

B)

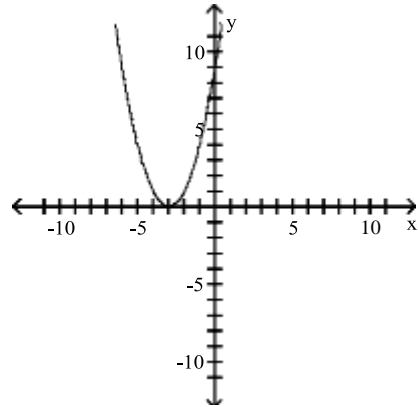

C)

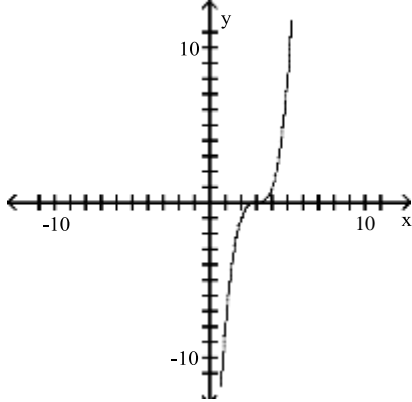

D)

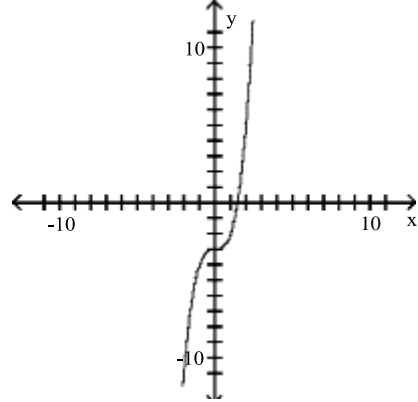

Answer: A

85) $y = \sqrt{x+2} + 1$

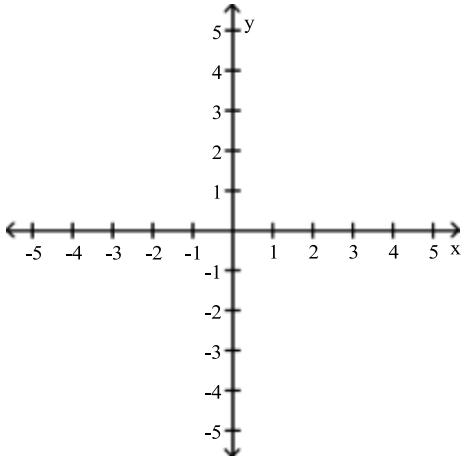

A)

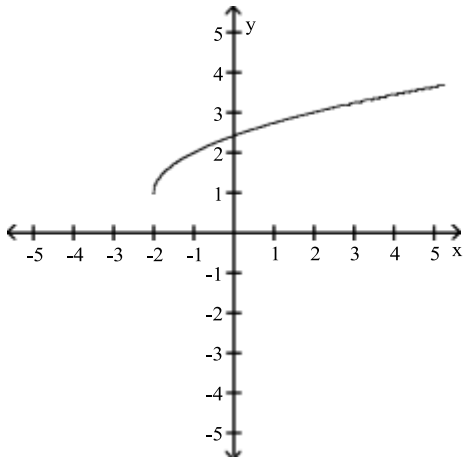

B)

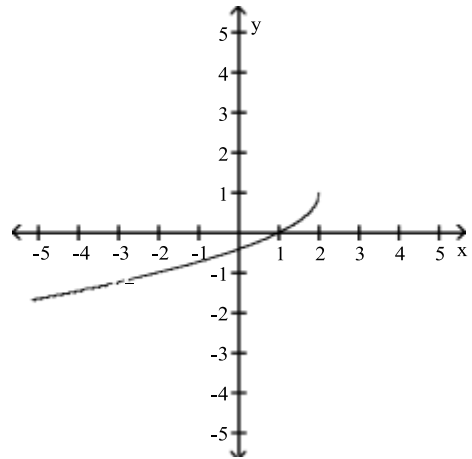

C)

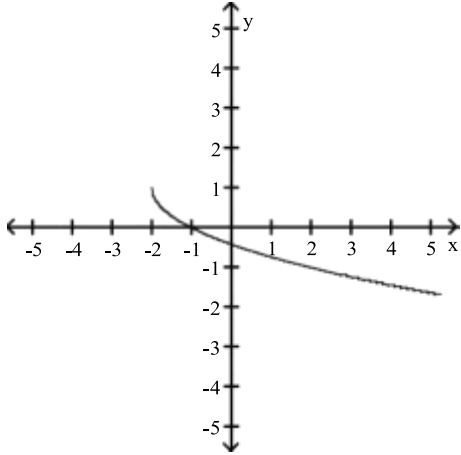

D)

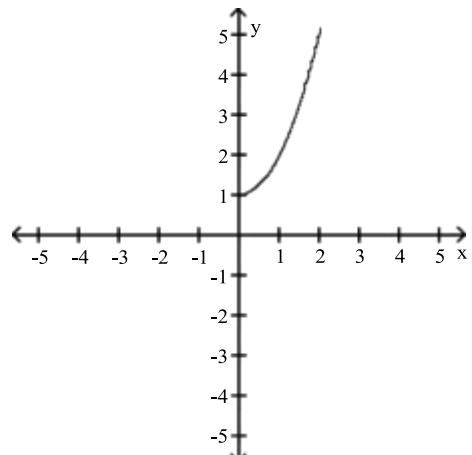

Answer: A

86) $y = |x - 3| - 5$

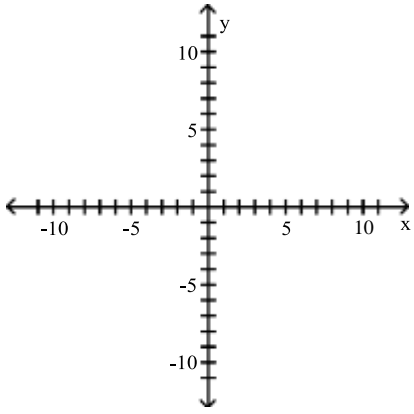

A)

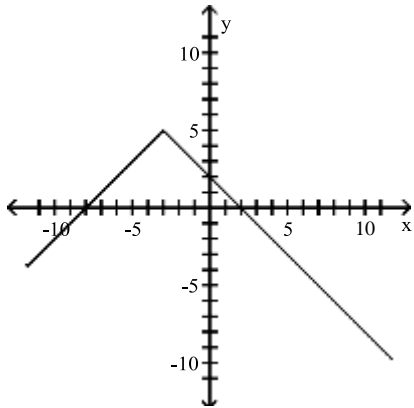

B)

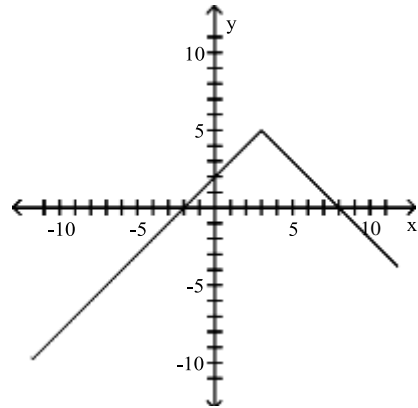

C)

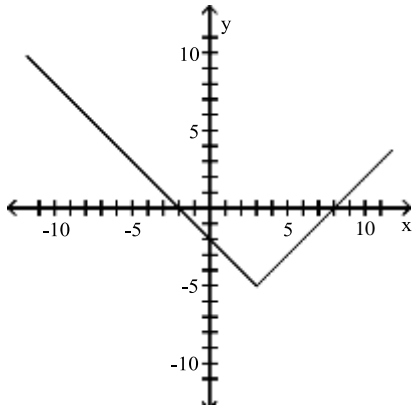

D)

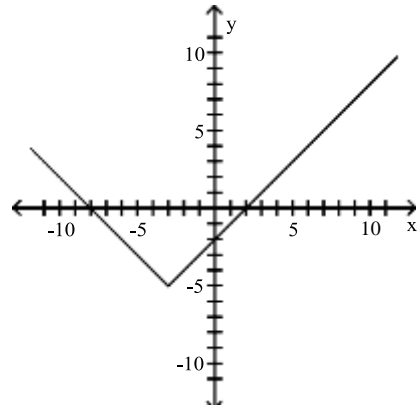

Answer: C

87) $y = (x - 4)^2 - 2$

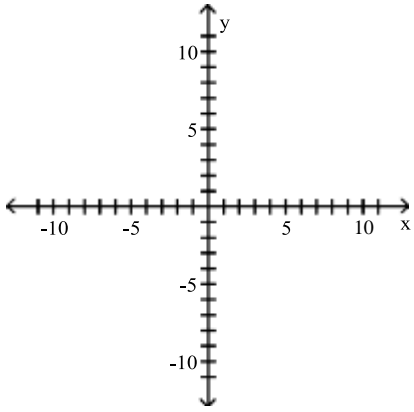

A)

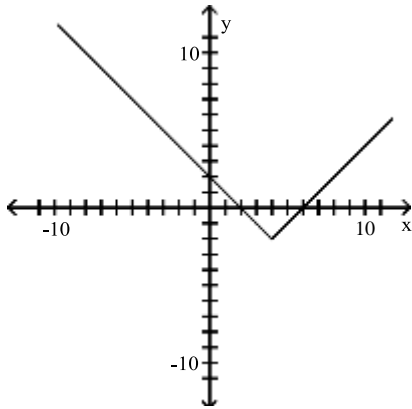

B)

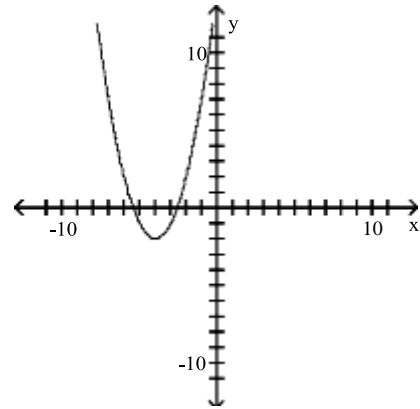

C)

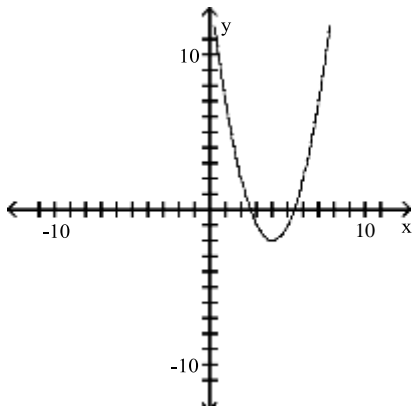

D)

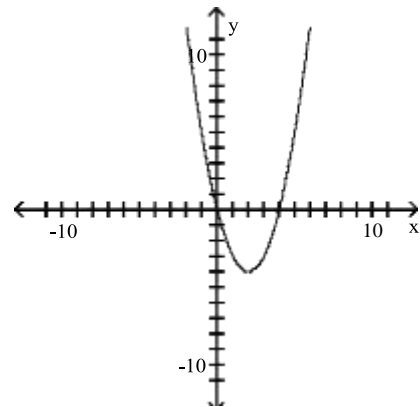

Answer: C

The function Y_2 is defined as $Y_1 + k$ for some real number k . Based upon the given information about Y_1 and Y_2 , find k .

88)

X	Y_1	Y_2
0	-1	3
1	0	4
2	3	7
3	8	12
4	15	19
5	24	28
6	35	39
X = 0		

A) 4

B) 5

C) 1

D) 2

Answer: A

89)

X	Y_1	Y_2
0	-3	-8
1	-2	-7
2	5	0
3	24	19
4	61	56
5	122	117
6	213	208
X = 0		

A) 4

B) -4

C) -5

D) 5

Answer: C

90)

X	Y_1	Y_2
0	-2	8
1	-1	9
2	6	16
3	25	35
4	62	72
5	123	133
6	214	224
X = 0		

A) -6

B) -10

C) 6

D) 10

Answer: D

91)

X	Y ₁	Y ₂
0	-3	-5
1	-2	-4
2	1	-1
3	6	4
4	13	11
5	22	20
6	33	31
X = 0		

A) -2

B) -1

C) 1

D) 2

Answer: A

92)

X	Y ₁	Y ₂
0	-3	-18
1	-2	-17
2	13	-2
3	78	63
4	253	238
5	622	607
6	1293	1278
X = 0		

A) -25

B) 28

C) 12

D) -15

Answer: D

93)

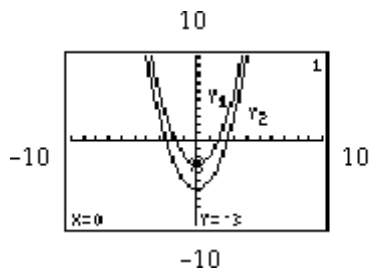

A) 4

B) -2

C) 5

D) -3

Answer: D

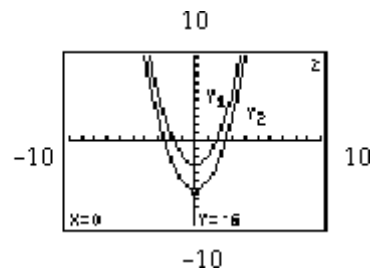

94)

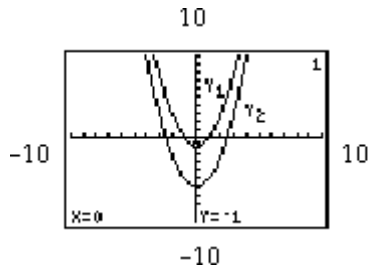

A) 4

B) 3

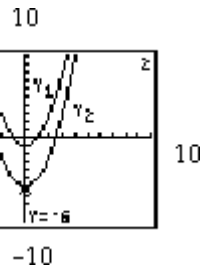

C) -1

D) -5

Answer: D

95)

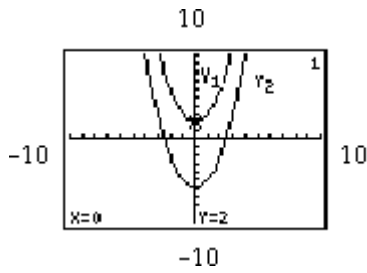

A) 7

B) 9

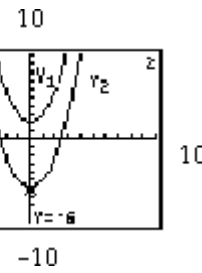

C) -6

D) -8

Answer: D

96)

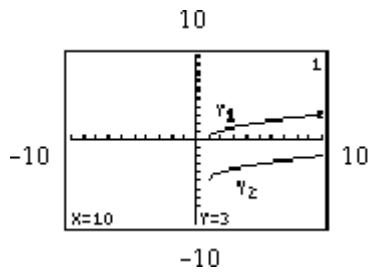

A) -5

B) 4

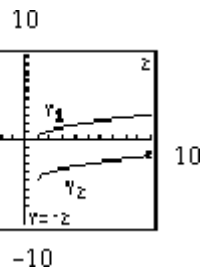

C) 3

D) -4

Answer: A

97)

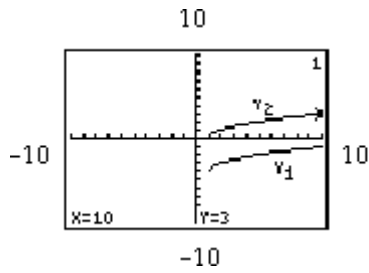

A) -4

B) 5

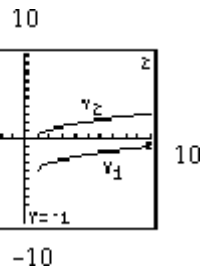

C) -5

D) 4

Answer: D

Determine the domain and range of the function from the graph.

98)

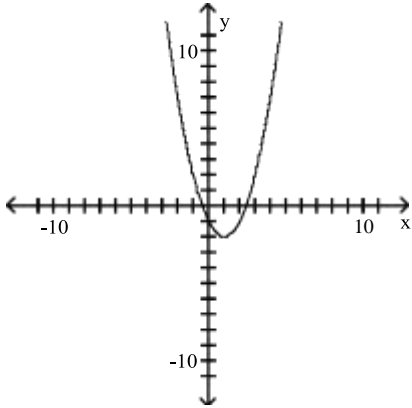

A) $(-\infty, \infty)$; $[-2, \infty)$

C) $(-\infty, 0) \cup (0, \infty)$; $(-\infty, 0) \cup (0, \infty)$

B) $(0, \infty)$; $[3, \infty)$

D) $(-\infty, 0)$; $(-\infty, 0)$

Answer: A

99)

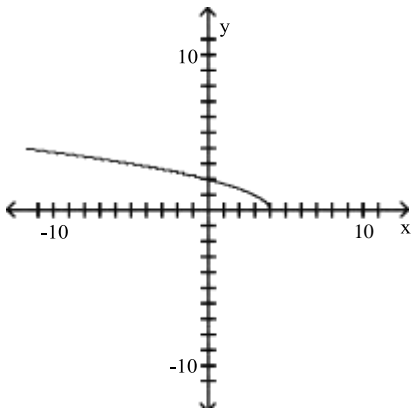

A) $(-\infty, 4]$; $[0, \infty)$

C) $(-\infty, \infty)$; $[0, \infty)$

B) $(-\infty, 4) \cup (4, \infty)$; $(-\infty, 0) \cup (0, \infty)$

D) $(\sqrt{4}, \infty)$; $(-\infty, 0]$

Answer: A

100)

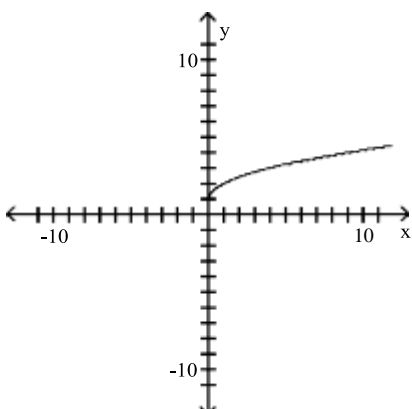

A) $[1, \infty)$; $[0, \infty)$

B) $[0, \infty)$; $[0, \infty)$

C) $[-1, \infty)$; $(-\infty, 0]$

D) $[0, \infty)$; $[1, \infty)$

Answer: D

101)

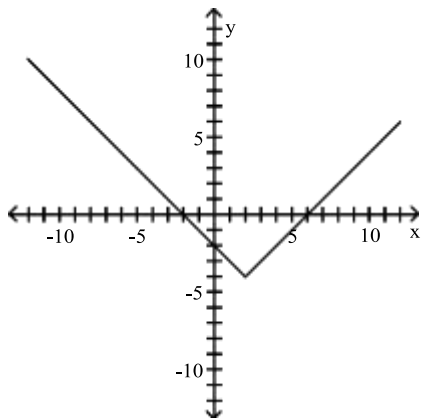

A) $(-\infty, \infty); [-4, \infty)$

B) $(-\infty, \infty); (-\infty, \infty)$

C) $(-\infty, \infty); [0, \infty)$

D) $[-4, \infty); (-\infty, \infty)$

Answer: A

102)

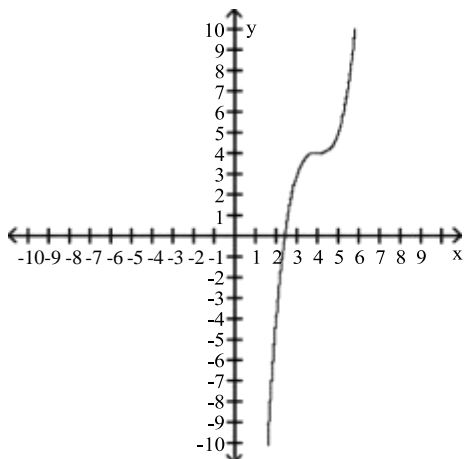

A) $(-\infty, \infty); [4, \infty)$

B) $(-\infty, \infty); (-\infty, \infty)$

C) $[4, \infty); (-\infty, \infty)$

D) $[0, \infty); [0, \infty)$

Answer: B

Use translations of one of the basic functions defined by $y = x^2$, $y = x^3$, $y = \sqrt{x}$, or $y = |x|$ to sketch a graph of $y = f(x)$ by hand. Do not use a calculator.

103) $y = x^2 - 5$

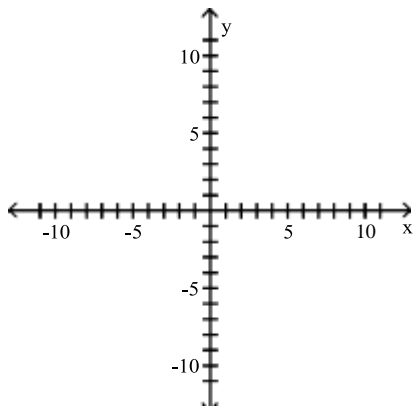

A)

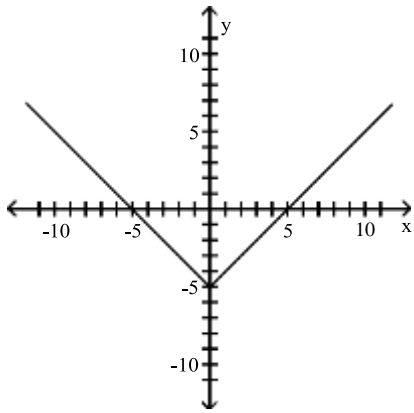

B)

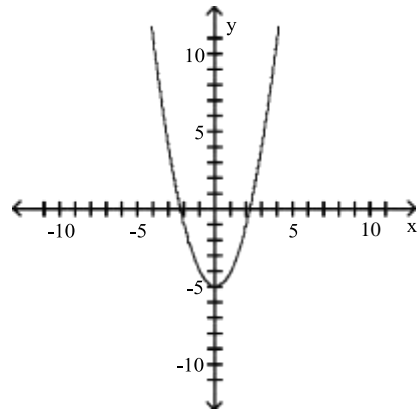

C)

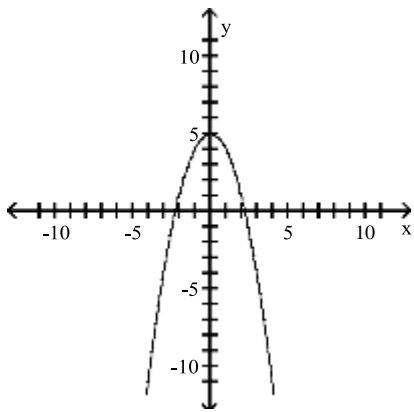

D)

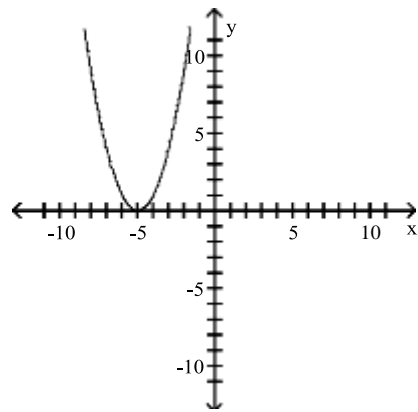

Answer: B

104) $y = |x - 2|$

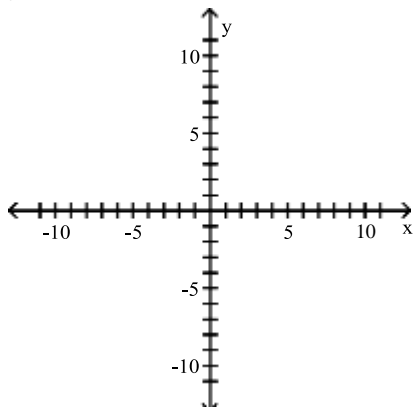

A)

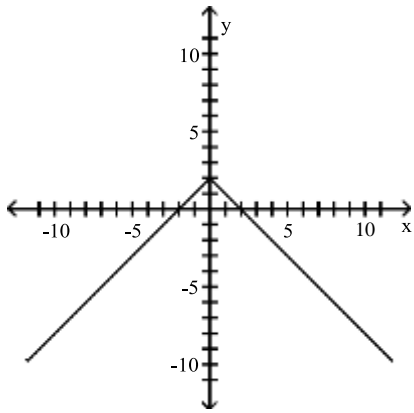

B)

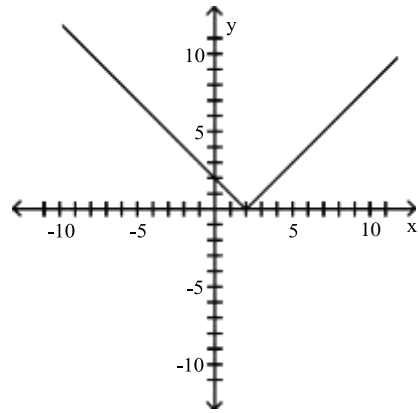

C)

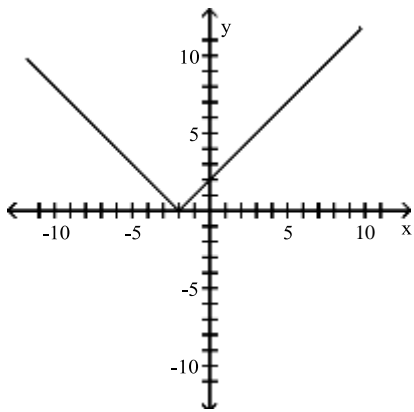

D)

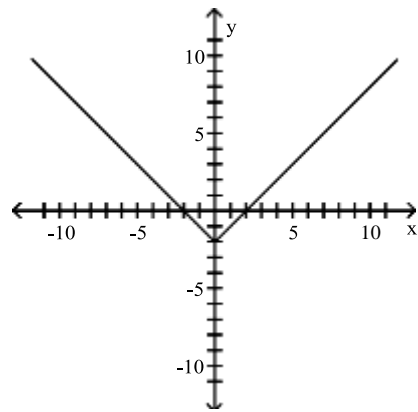

Answer: B

105) $y = (x + 5)^3$

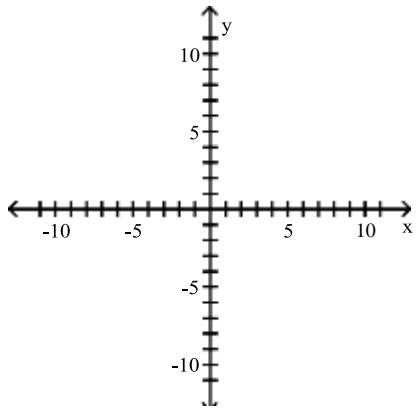

A)

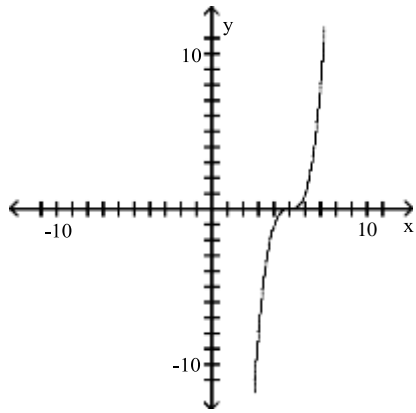

B)

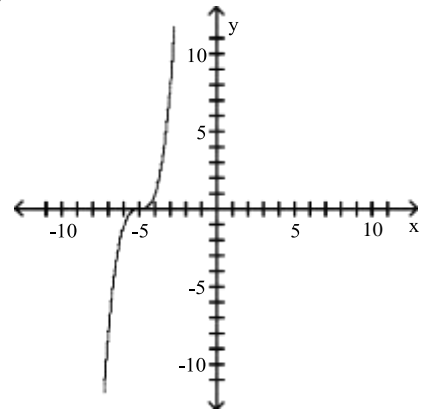

C)

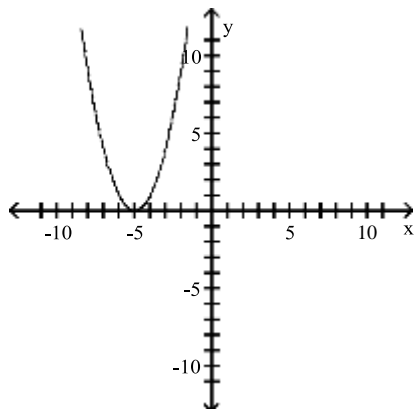

D)

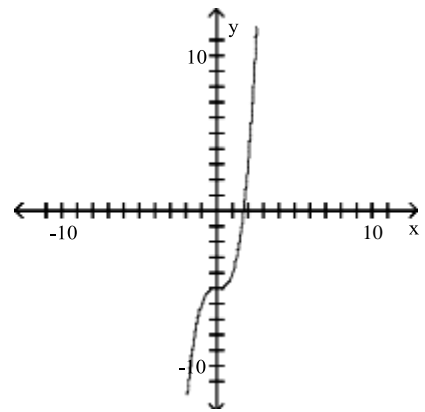

Answer: B

106) $y = x^3 + 4$

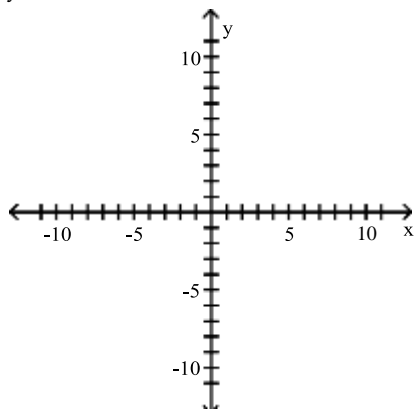

A)

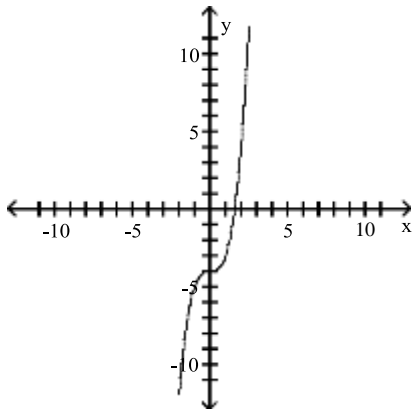

B)

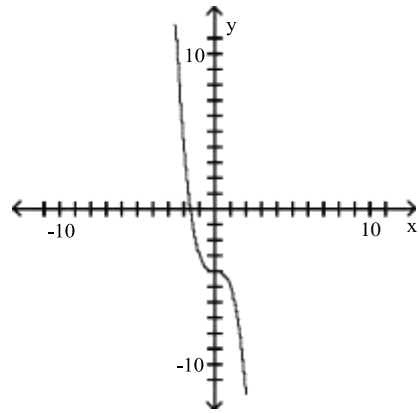

C)

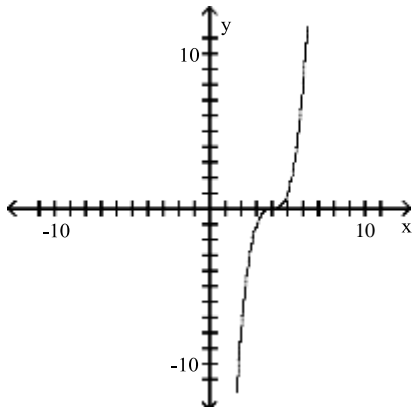

D)

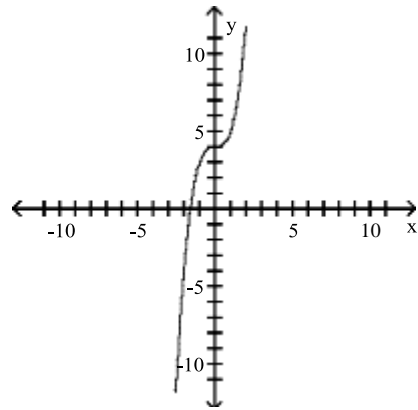

Answer: D

107) $y = \sqrt{x+3}$

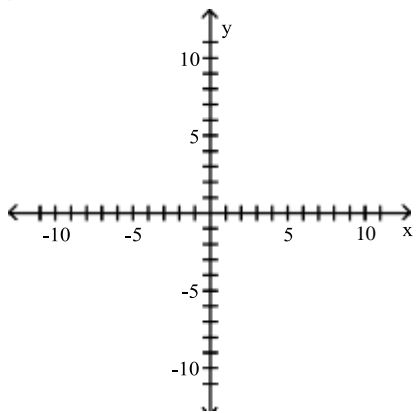

A)

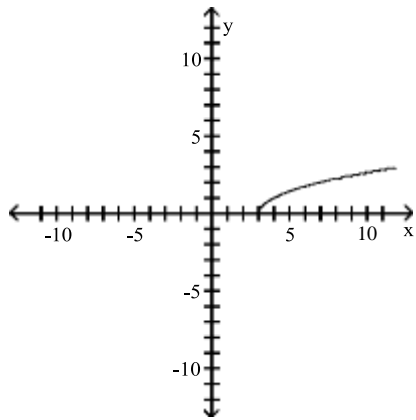

B)

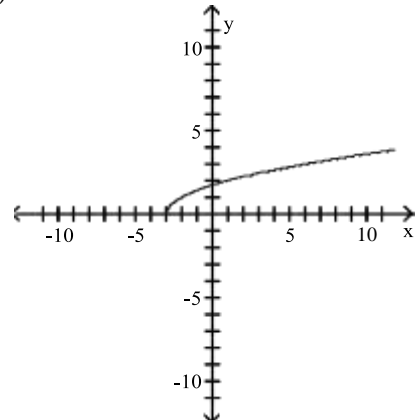

C)

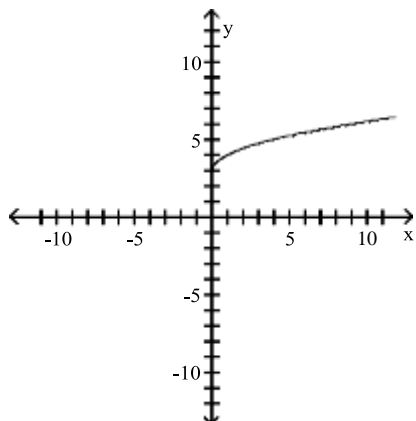

D)

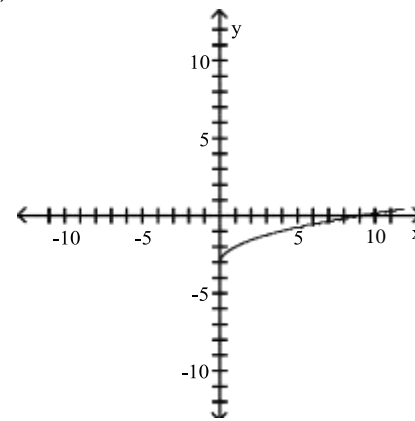

Answer: B

108) $y = -2 + |x|$

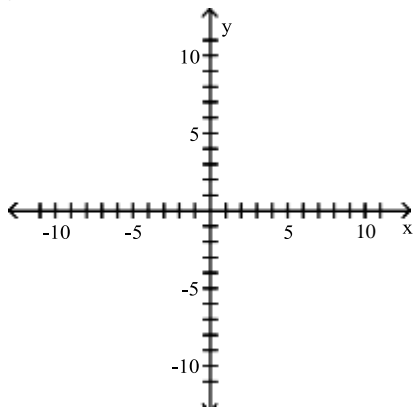

A)

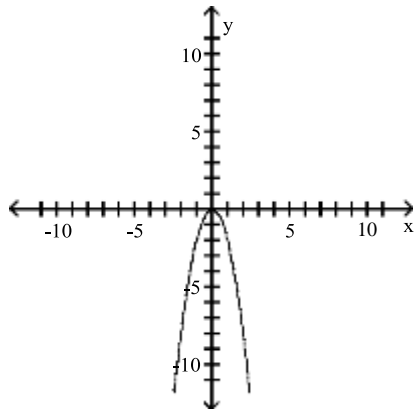

B)

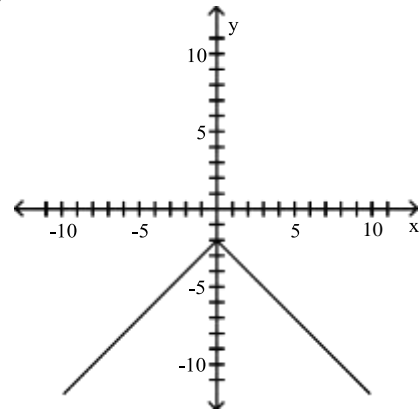

C)

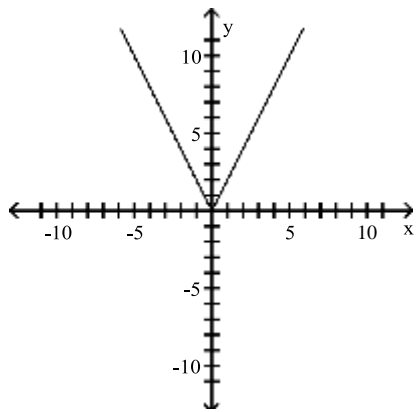

D)

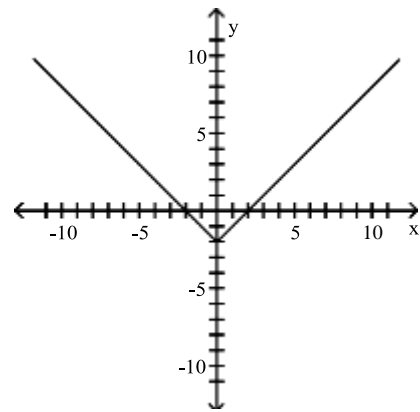

Answer: D

109) $y = (x - 2)^2 - 6$

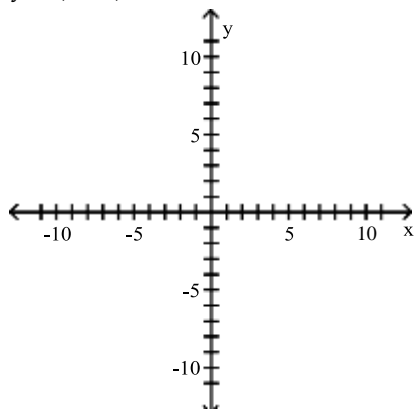

A)

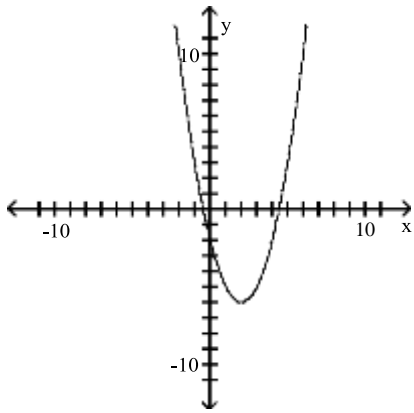

B)

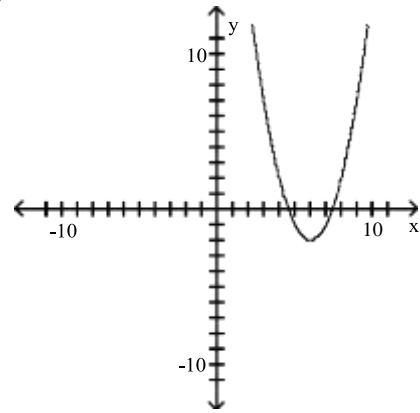

C)

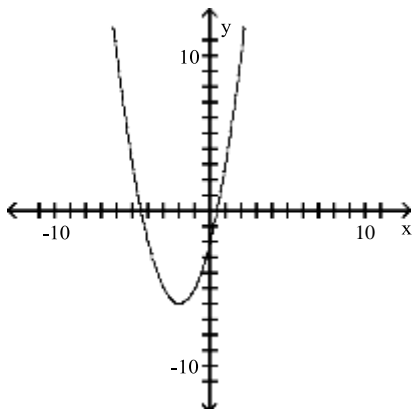

D)

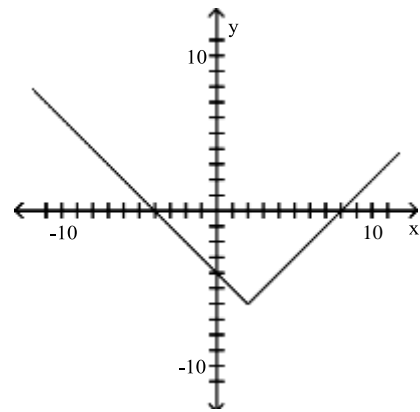

Answer: A

110) $y = (x + 2)^3 - 6$

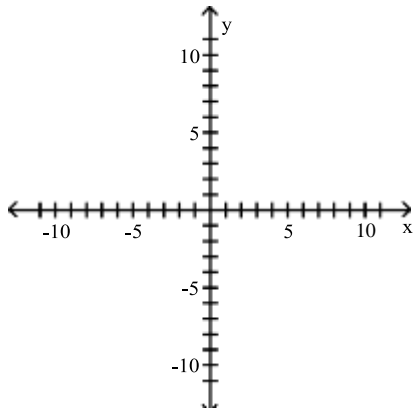

A)

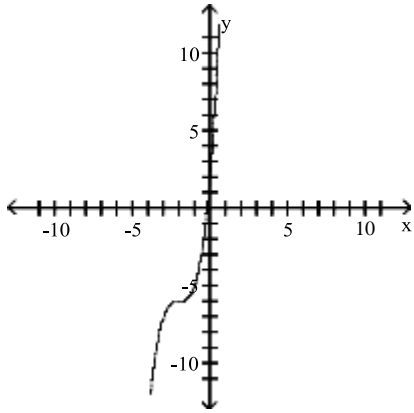

B)

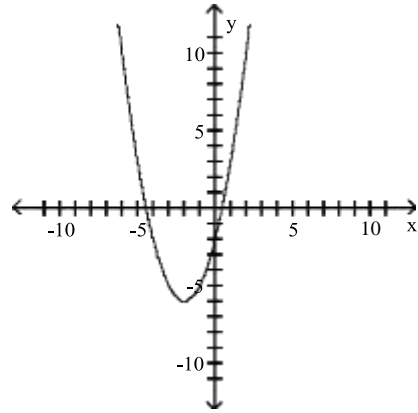

C)

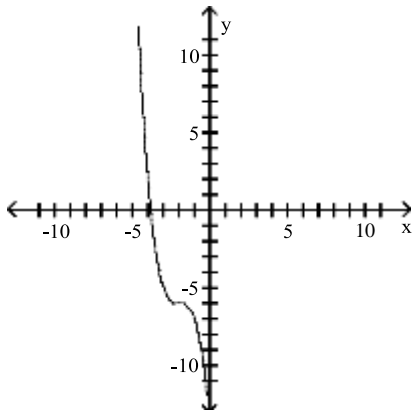

D)

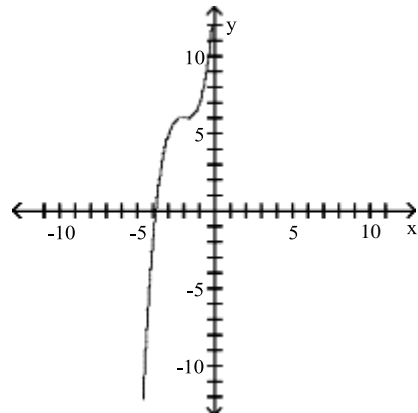

Answer: A

111) $y = (x - 6)^2 - 1$

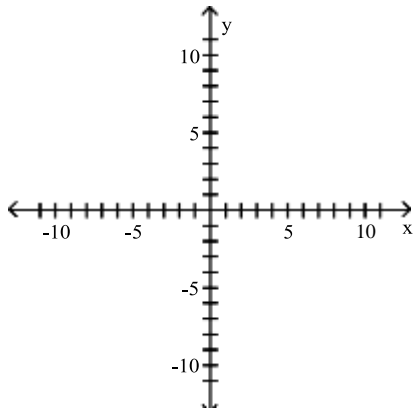

A)

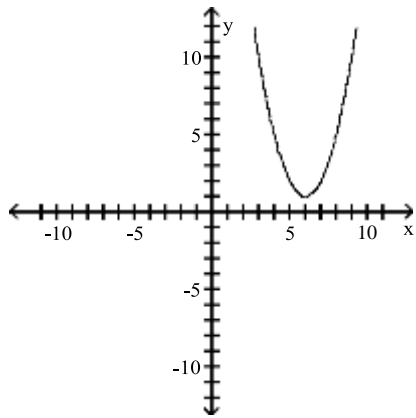

B)

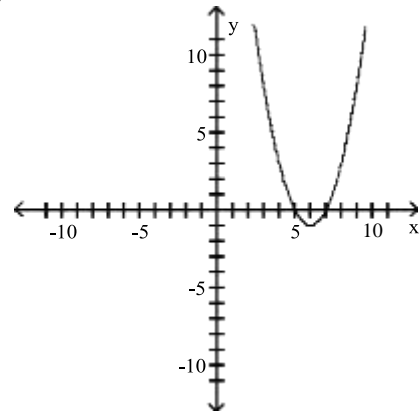

C)

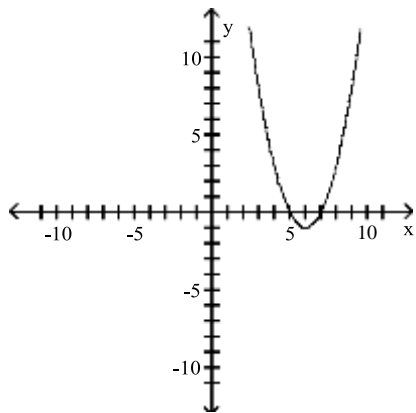

D)

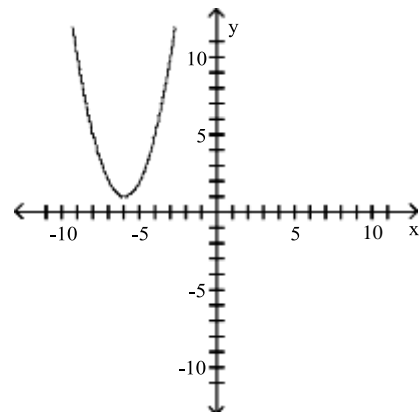

Answer: B

112) $y = |x - 3| + 2$

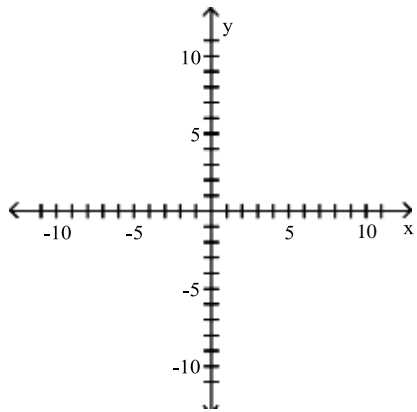

A)

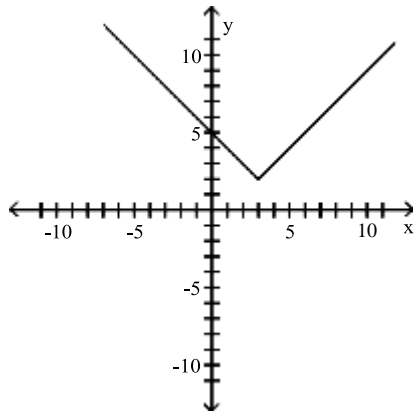

B)

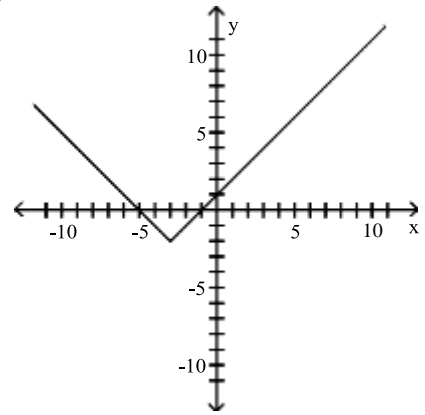

C)

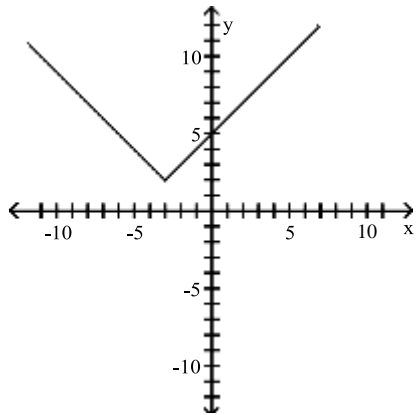

D)

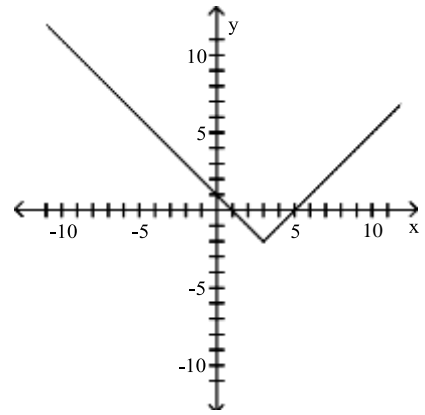

Answer: A

113) $y = \sqrt{x-7} + 4$

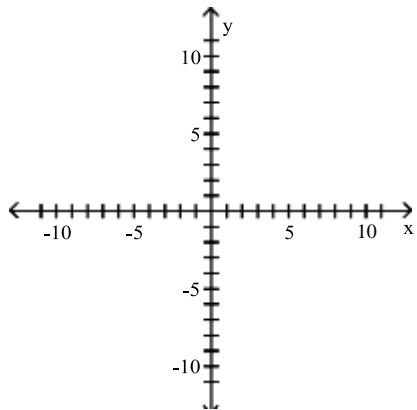

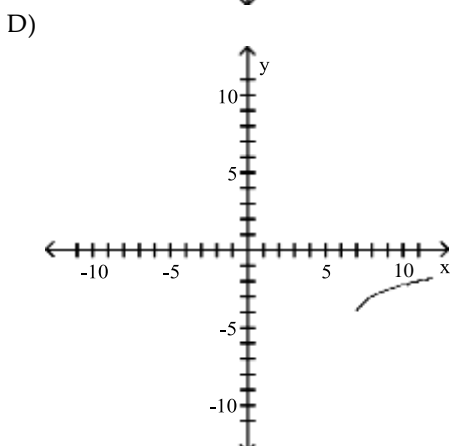
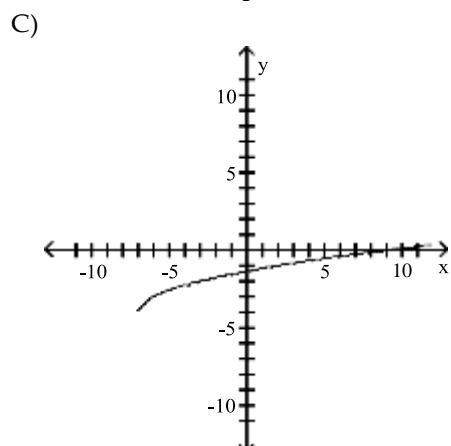
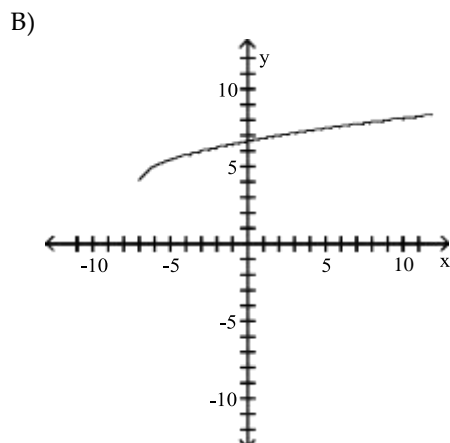
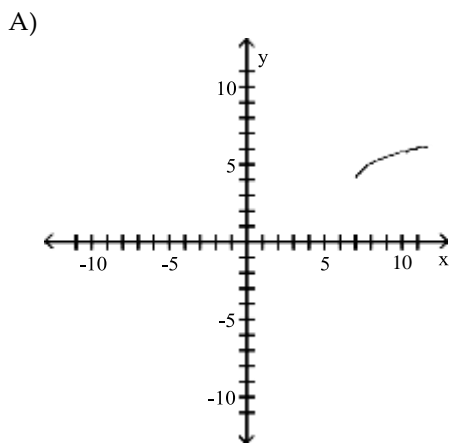

Answer: A

The graph is a translation of one of the basic functions defined by $y = x^2$, $y = x^3$, $y = \sqrt{x}$, or $y = |x|$. Find the equation that defines the function.

114)

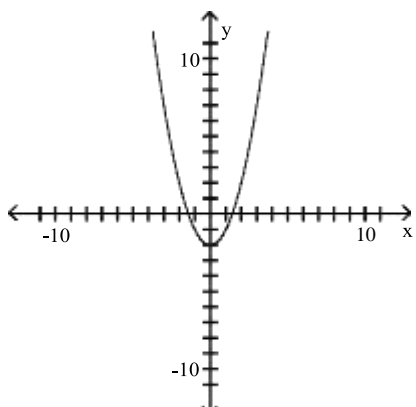

A) $y = x^2 - 2$

B) $y = (x - 2)^2 + 2$

C) $y = (x - 2)^2$

D) $y = (x + 2)^2$

Answer: A

115)

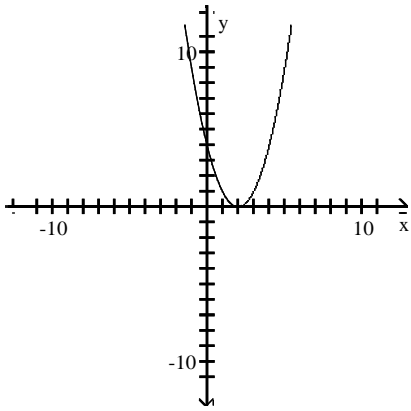

A) $y = (x - 2)^2$

B) $y = x^2 - 2$

C) $y = (x - 2)^2 + 2$

D) $y = (x + 2)^2$

Answer: A

116)

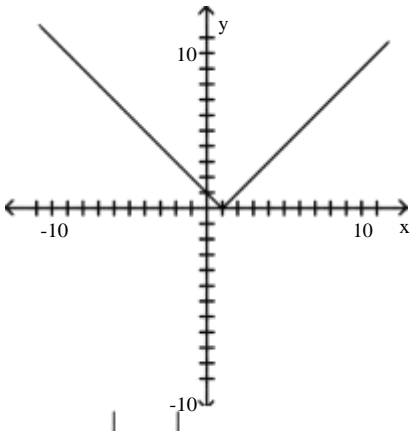

A) $y = x + 1$

B) $y = |x - 1| + 3$

C) $y = |x - 1|$

D) $y = |x| - 1$

Answer: C

117)

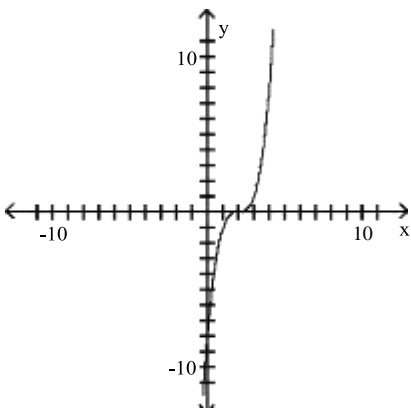

A) $y = (x + 2)^3$

B) $y = (x - 2)^3$

C) $y = (x - 2)^3 + 1$

D) $y = x^3 - 2$

Answer: B

118)

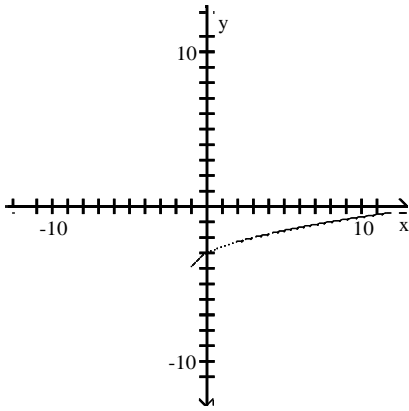

A) $y = \sqrt{x - 1}$

B) $y = \sqrt{x + 1} - 4$

C) $y = \sqrt{x + 1}$

D) $y = \sqrt{x} - 4$

Answer: B

119)

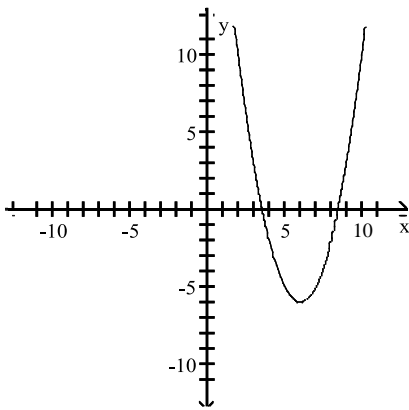

A) $y = (x - 5)^2 - 6$

B) $y = (x - 6)^2 - 6$

C) $y = -5(x - 6)^2$

D) $y = 5(x + 6)^2$

Answer: B

Find the linear equation that meets the stated criteria.

120) The linear equation $y = 226x + 6320$ provides an approximation of the annual cost (in dollars) to rent an apartment at the Leisure Village Retirement Community, where $x = 1$ represents 1989, $x = 2$ represents 1990, and so on. Write an equation that yields the same y -values when the exact year number is entered.

A) $y = 226(1988 - x) + 6320$

B) $y = 226(x - 1989) + 6320$

C) $y = 226(1989 - x) + 6320$

D) $y = 226(x - 1988) + 6320$

Answer: D

121) The linear equation $y = 466x + 3420$ provides an approximation of the annual cost (in dollars) of health insurance for a family of three, where $x = 1$ represents 1981, $x = 2$ represents 1982, and so on. Write an equation that yields the same y -values when the exact year number is entered.

A) $y = 466(x - 1980) + 3420$

B) $y = 466(1981 - x) + 3420$

C) $y = 466(x - 1981) + 3420$

D) $y = 466(1980 - x) + 3420$

Answer: A

- 122) The linear equation $y = 81.2x + 1160$ provides an approximation of the value (in dollars) of an account opened on January 1, 1997, in the amount of \$1160 and earning 7% simple interest, where $x = 0$ represents January 1, 1997, $x = 1$ represents January 1, 1998, $x = 2$ represents January 1, 1999, and so on. Write an equation that yields the same y -values when the exact year number is entered.

A) $y = 81.2(x - 1998) + 1160$
 C) $y = 81.2(1998 - x) + 1160$

B) $y = 81.2(x - 1997) + 1160$
 D) $y = 81.2(1997 - x) + 1160$

Answer: B

- 123) The table shows the number of members in the Windy City Edsel Owners Club during the years 1980-1984.

Year	Number of Members
1980	64
1981	71
1982	75
1983	86
1984	99

Use a calculator to find the least squares regression line for this data, where $x = 0$ represents 1980, $x = 1$ represents 1981, and so on.

A) $y = 7.9x + 63$

B) $y = 8.1x + 59$

C) $y = 8.3x + 61$

D) $y = 8.5x + 62$

Answer: D

- 124) The table shows the number of members in the Windy City Edsel Owners Club during the years 1986-1990.

Year	Number of Members
1986	111
1987	132
1988	167
1989	197
1990	219

Use a calculator to find the least squares regression line for this data, where $x = 0$ represents 1986, $x = 1$ represents 1987, and so on.

A) $y = 28.4x + 105$

B) $y = 28.1x + 109$

C) $y = 28.3x + 106$

D) $y = 27.6x + 111$

Answer: B

Provide an appropriate response.

- 125) Explain how the graph of $g(x) = f(x) - 2$ is obtained from the graph of $y = f(x)$.

A) Shift the graph of f downward 2 units.

B) Shift the graph of f upward 2 units.

C) Shift the graph of f to the right 2 units.

D) Shift the graph of f to the left 2 units.

Answer: A

- 126) Explain how the graph of $g(x) = f(x - 8)$ is obtained from the graph of $y = f(x)$.

A) Shift the graph of f to the right 8 units.

B) Shift the graph of f downward 8 units.

C) Shift the graph of f to the left 8 units.

D) Shift the graph of f upward 8 units.

Answer: A

- 127) Which function represents a vertical translation of the parabola $y = (x - 3)^2 + 5$?

A) $y = -(x - 3)^2 + 5$

B) $y = (x + 3)^2 + 5$

C) $y = (x - 3)^2 + 8$

D) $y = x^2 + 5$

Answer: C

128) The graph shown is a translation of the function $y = |x|$. The graph shown is of the form $y = |x - h| + k$. What are the values of h and k ?

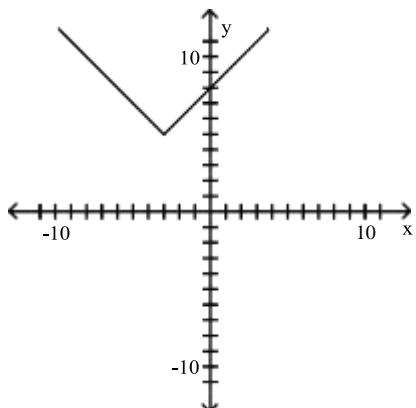

A) $h = -3, k = -5$

B) $h = 3, k = 5$

C) $h = -3, k = 5$

D) $h = 3, k = -5$

Answer: C

129) Sketch the graph of $y = f(x - 3)$ for the given graph of $y = f(x)$.

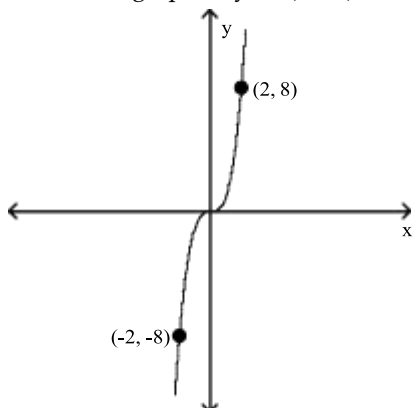

A)

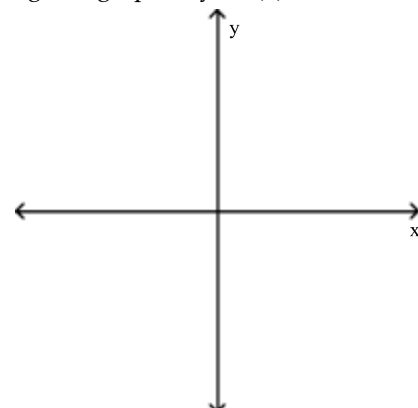

B)

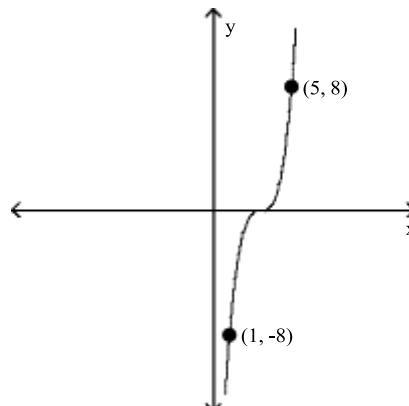
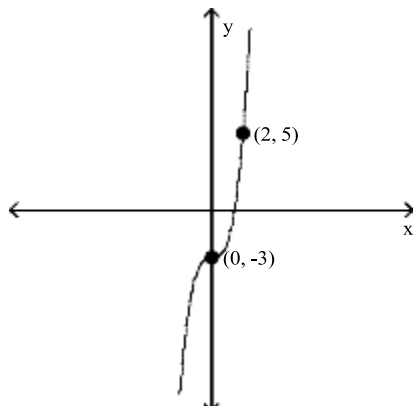

C)

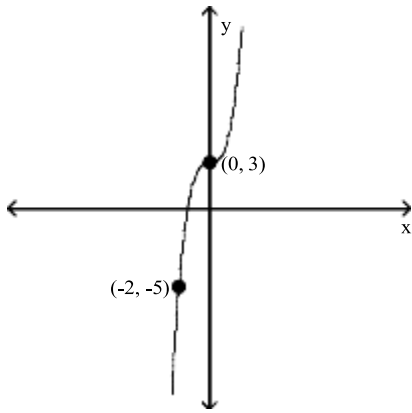

D)

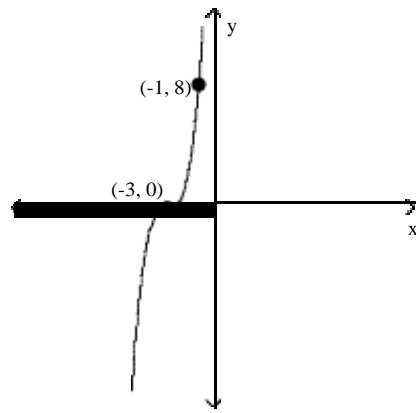

Answer: B

130) Sketch the graph of $y = f(x + 2)$ for the given graph of $y = f(x)$.

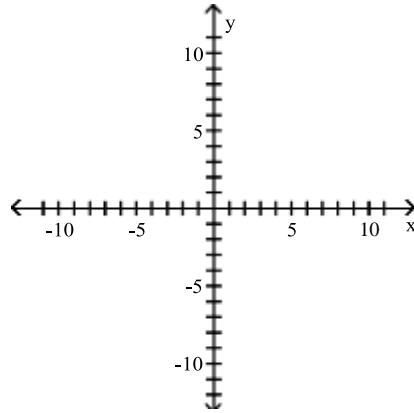
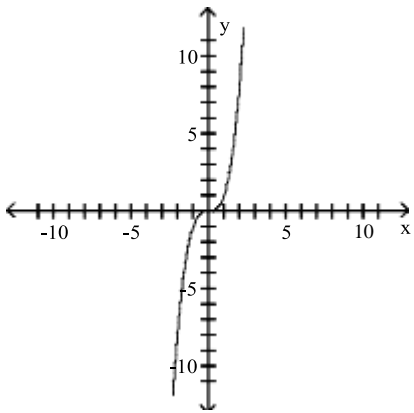

A)

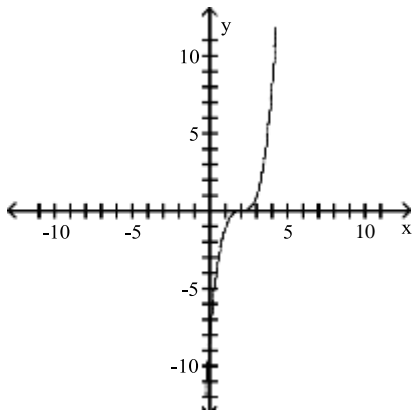

B)

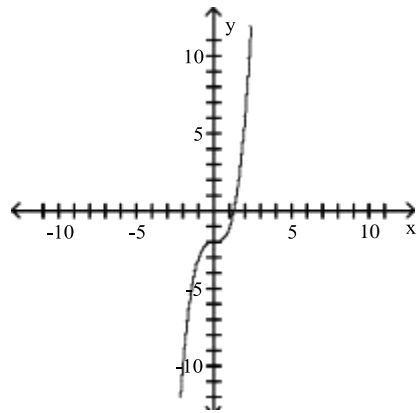

C)

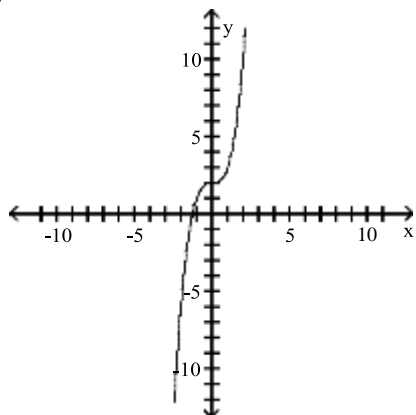

D)

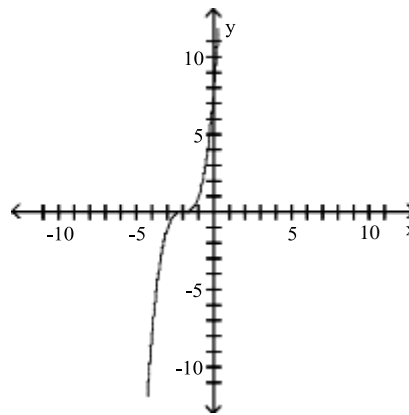

Answer: D

131) Use the graph of $y = f(x)$ to find the x-intercepts of the graph of $y = f(x + 2)$.

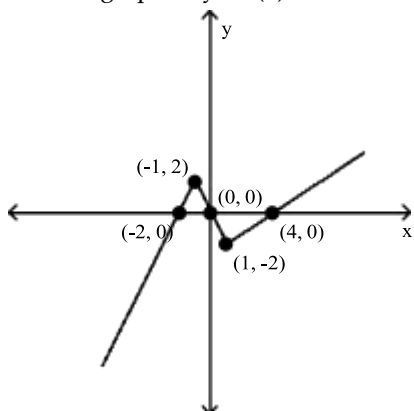

A) 0, 2, 6

B) -2, 0, 4

C) -3, 0

D) -4, -2, 2

Answer: D

Write the equation that results in the desired transformation.

132) The square root function, reflected across the x-axis

A) $y = \sqrt{x}$

B) $y = \sqrt{x} - 1$

C) $y = \sqrt{-x}$

D) $y = -\sqrt{x}$

Answer: D

133) The squaring function, vertically stretched by a factor of 5

A) $y = (x - 5)^2$

B) $y = 5(x - 5)x^2$

C) $y = -5x^2$

D) $y = 5x^2$

Answer: D

134) The cubing function, vertically shrunk by a factor of 0.2

A) $y = 0.2x^3$

B) $y = (x + 0.2)^3$

C) $y = 0.2\sqrt[3]{x}$

D) $y = (x - 0.2)^3$

Answer: A

135) The squaring function, vertically stretched by a factor of 9 and reflected across the x-axis

A) $y = -9x^2$

B) $y = (x - 9)^2$

C) $y = 9(x - 9)x^2$

D) $y = 9x^2$

Answer: A

- 136) The absolute value function, vertically stretched by a factor of 3.3 and reflected across the x-axis
 A) $y = -|x + 3.3|$ B) $y = 3.3|x|$ C) $y = 3.3|-x|$ D) $y = -3.3|x|$

Answer: D

- 137) The absolute value function, vertically stretched by a factor of 1.9 and reflected across the y-axis
 A) $y = |-x + 1.9|$ B) $y = |-x - 1.9|$ C) $y = -1.9|x|$ D) $y = 1.9|-x|$

Answer: D

Use transformations of graphs to sketch the graphs of y_1 and y_2 . Graph y_2 as a dashed curve.

138) $y_1 = x^2$; $y_2 = x^2 - 6$

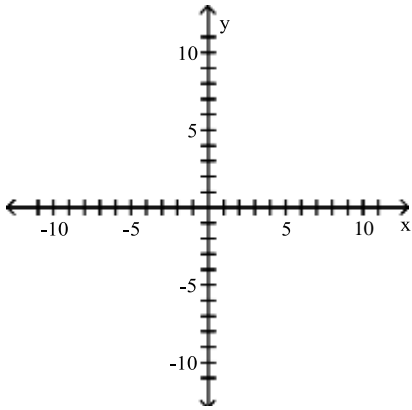

A)

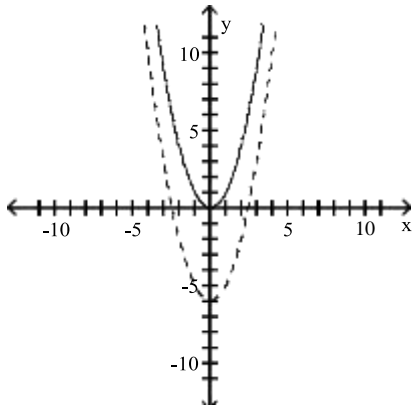

B)

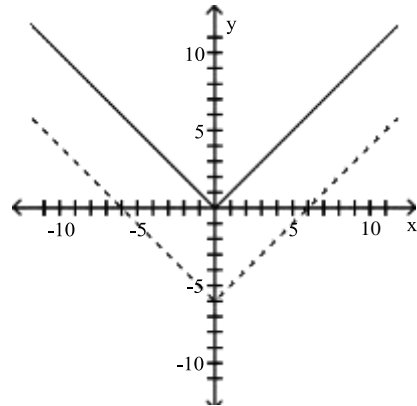

C)

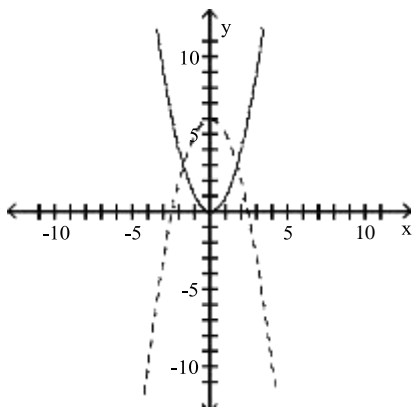

D)

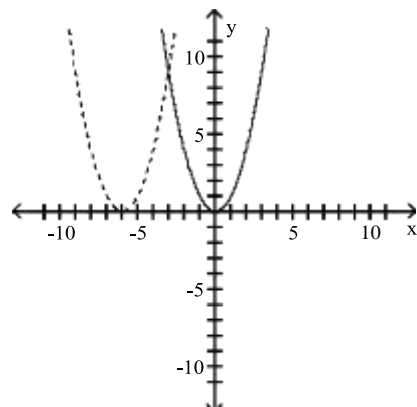

Answer: A

139) $y_1 = |x|$; $y_2 = |x - 6|$

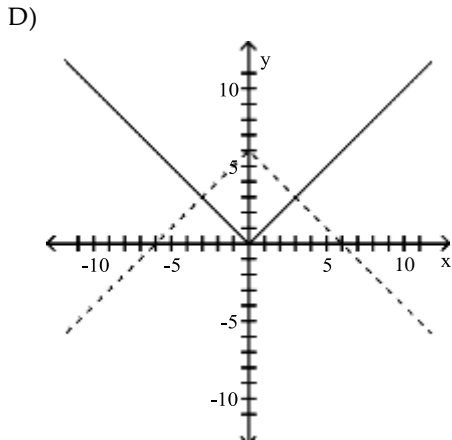
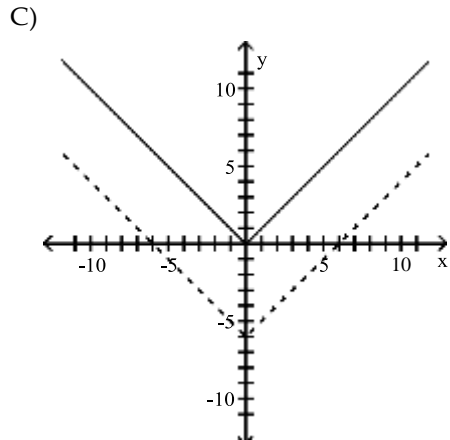
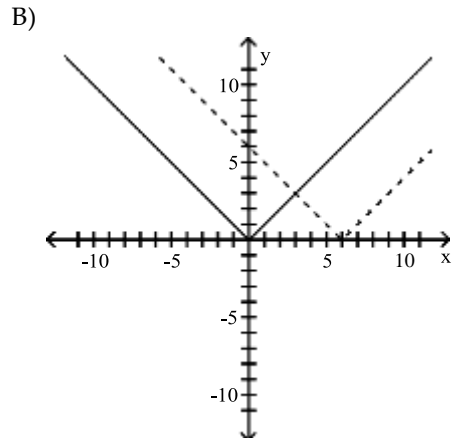
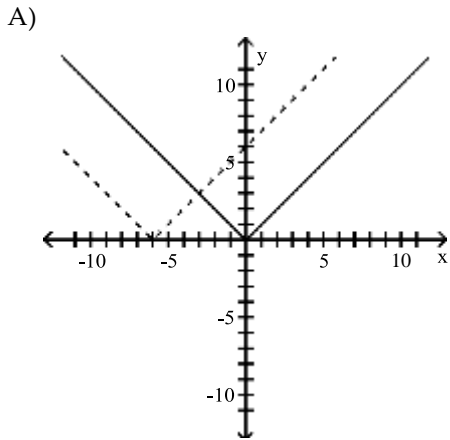
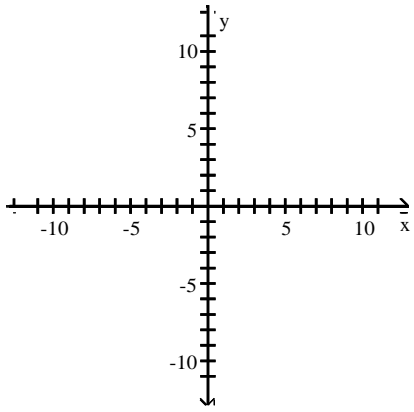

Answer: B

140) $y_1 = x^3$; $y_2 = (x + 5)^3$

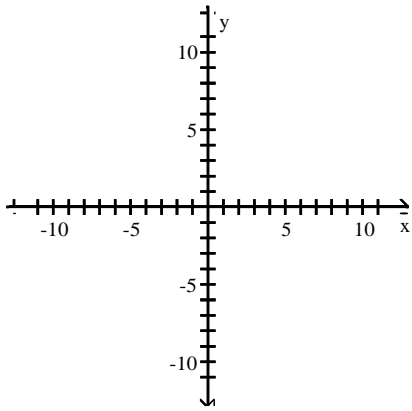

A)

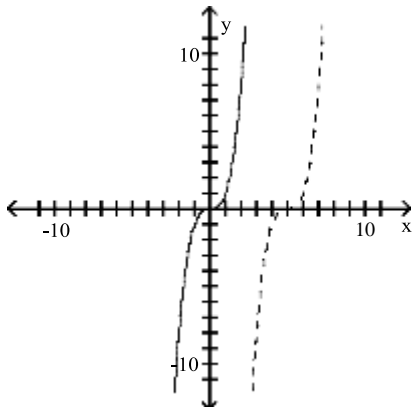

B)

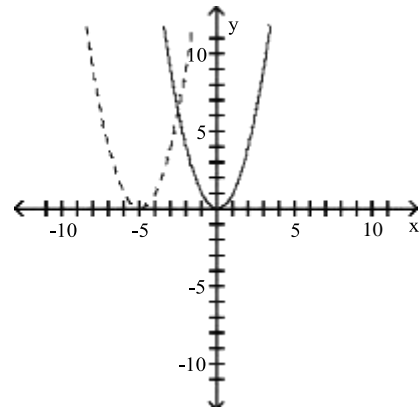

C)

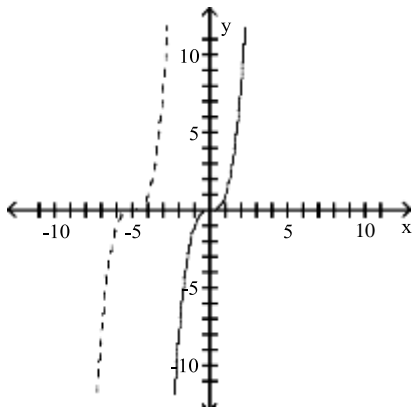

D)

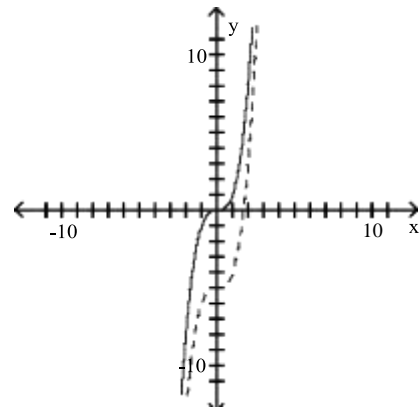

Answer: C

141) $y_1 = |x|$; $y_2 = -3|x|$

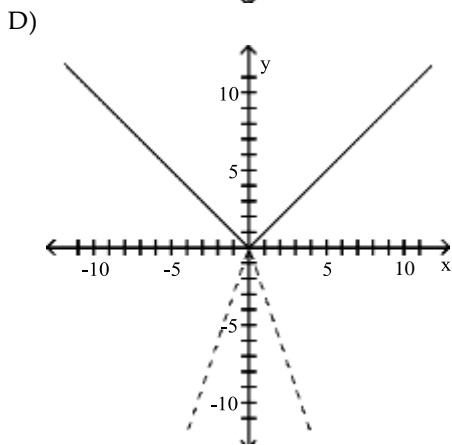
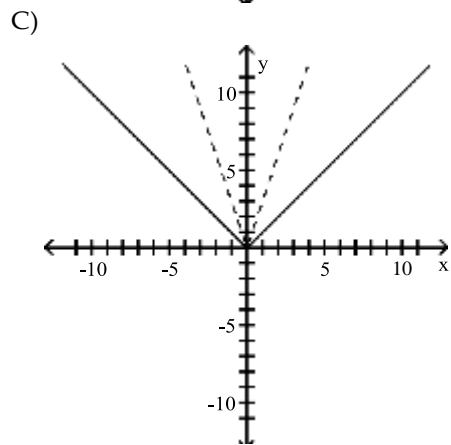
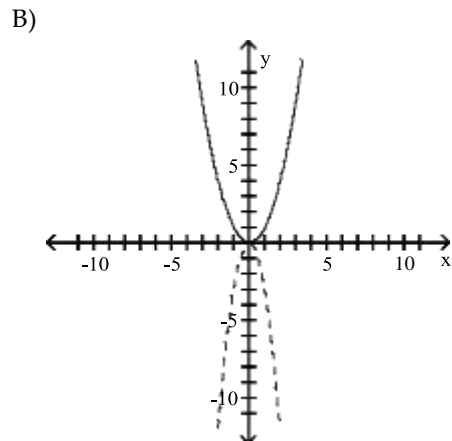
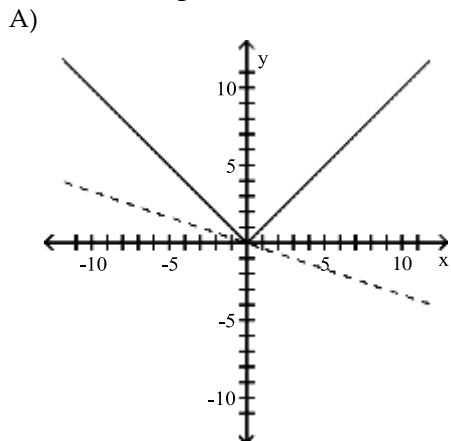
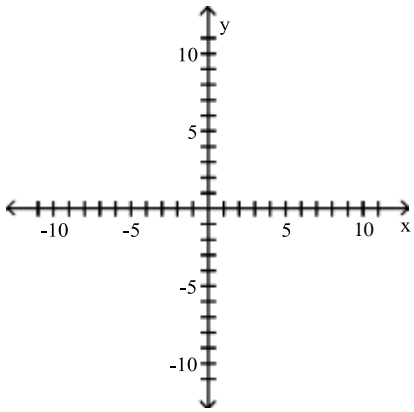

Answer: D

142) $y_1 = x^2$; $y_2 = (x - 5)^2 - 3$

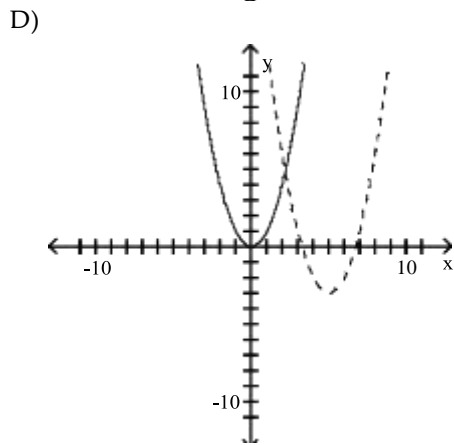
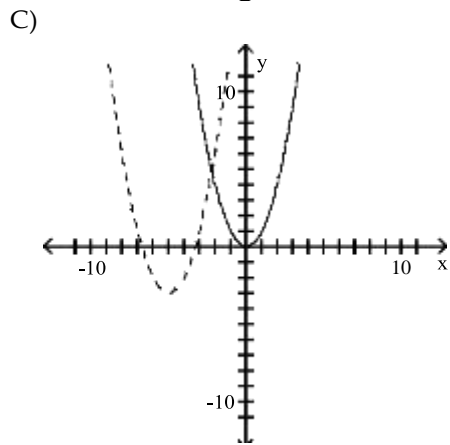
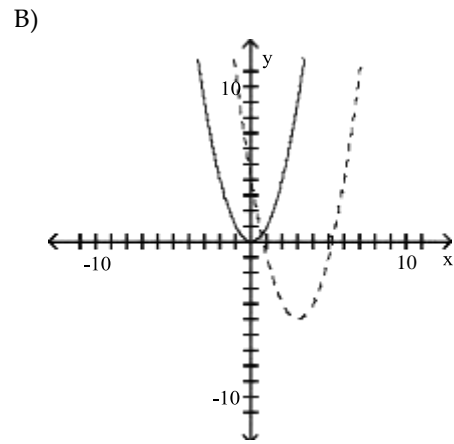
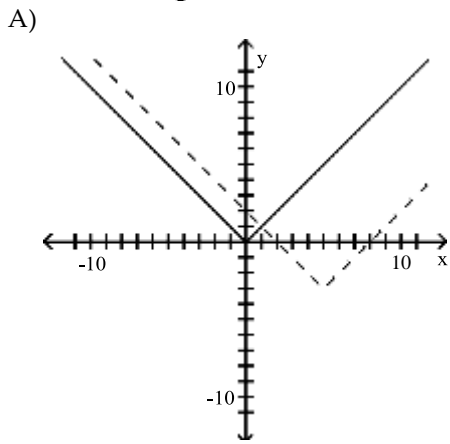
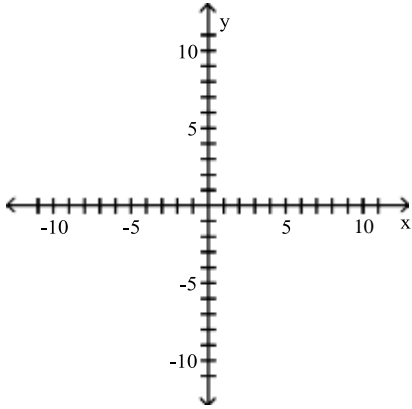

Answer: D

143) $y_1 = x^2$, $y_2 = -\frac{1}{4}(x + 4)^2 + 3$

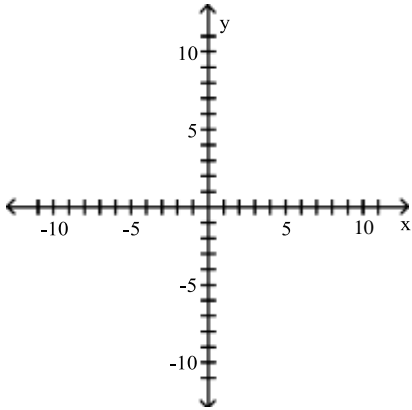

A)

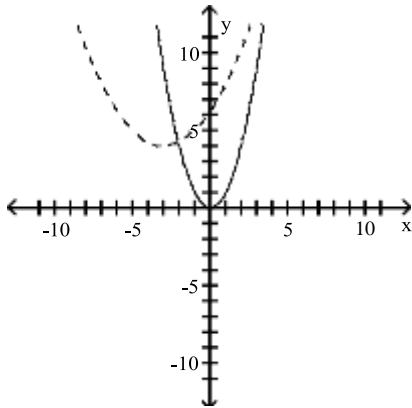

B)

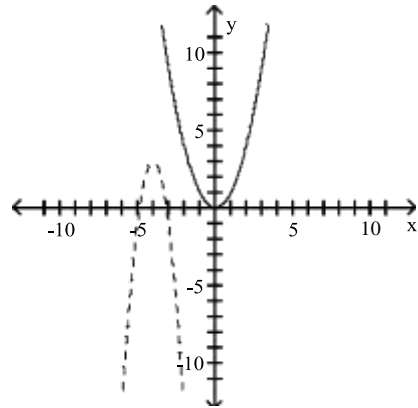

C)

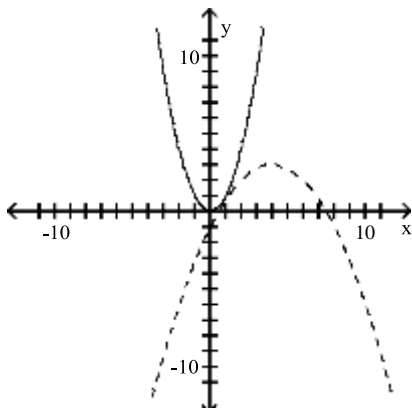

D)

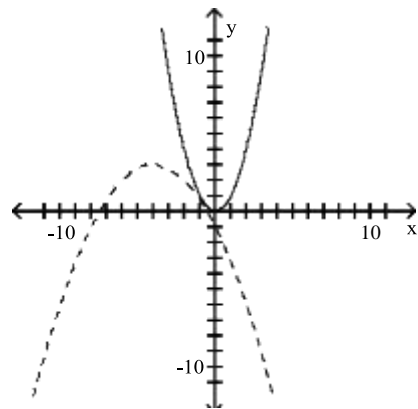

Answer: D

144) $y_1 = \sqrt[3]{x}$, $y_2 = \sqrt[3]{x} + 3$

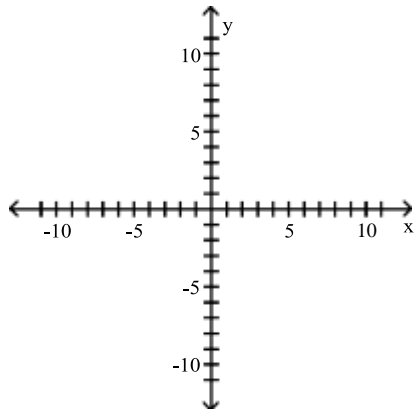

A)

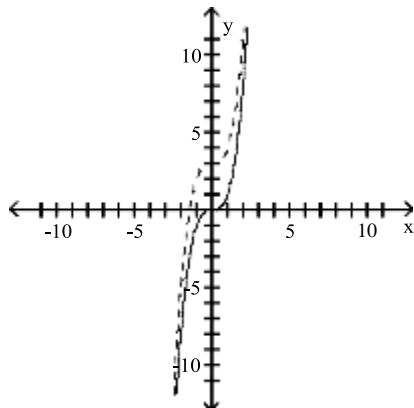

C)

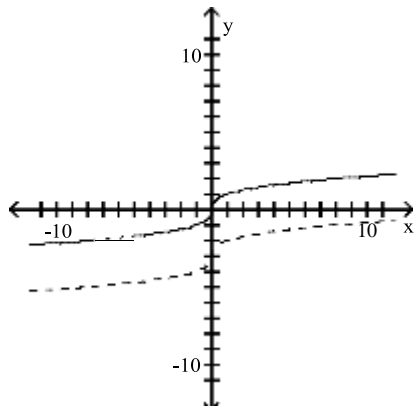

B)

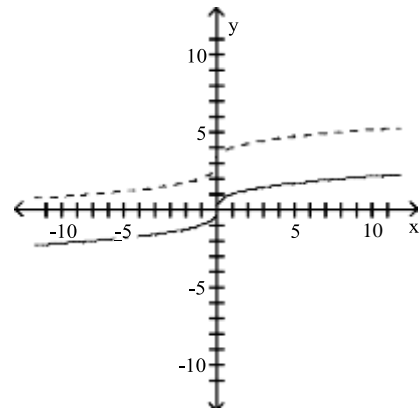

D)

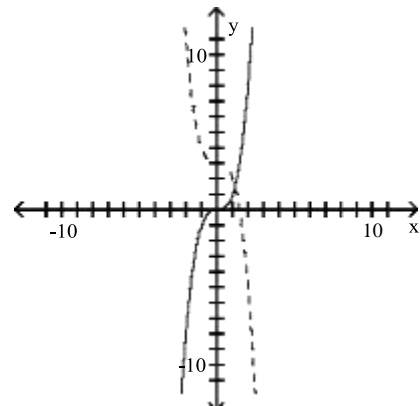

Answer: B

$$145) y_1 = \left| \frac{x}{2} + 3 \right| - 4$$

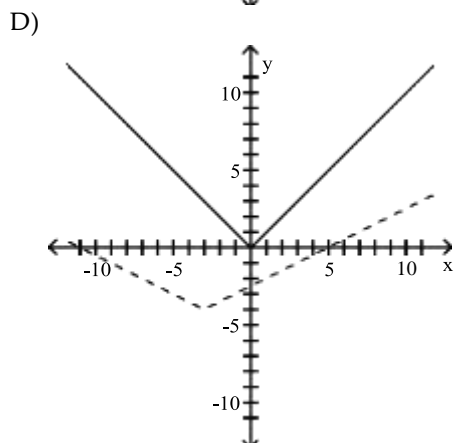
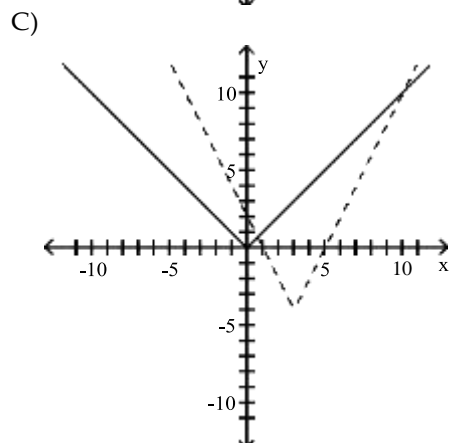
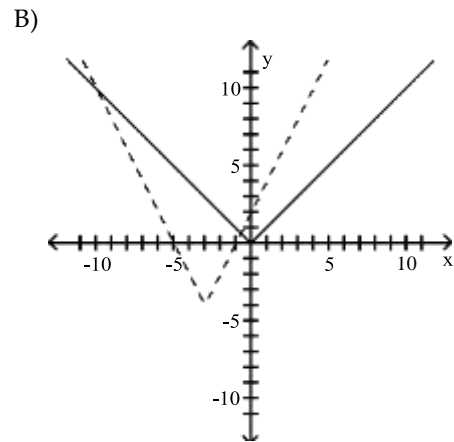
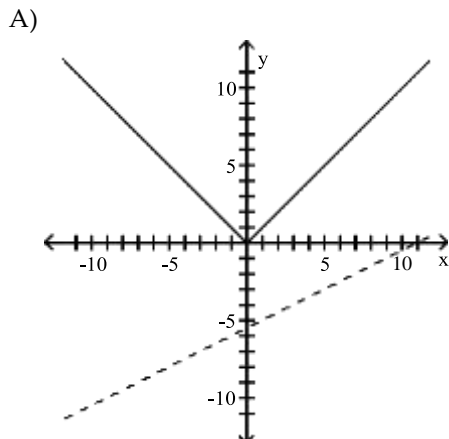
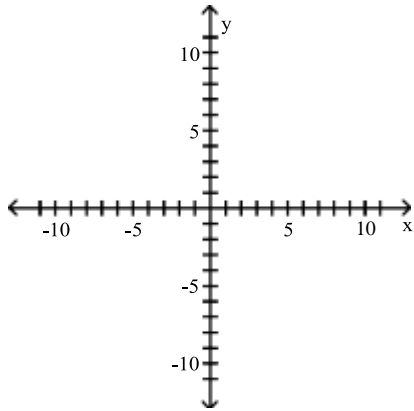

Answer: D

146) $y_1 = \sqrt[3]{x}$, $y_2 = \sqrt[3]{-x} + 2$

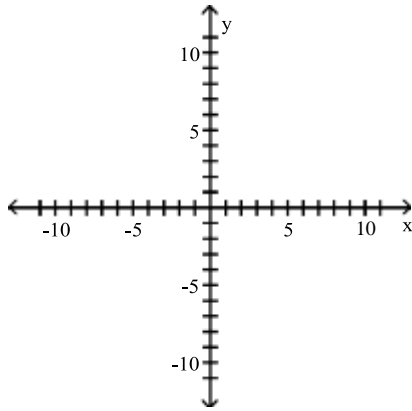

A)

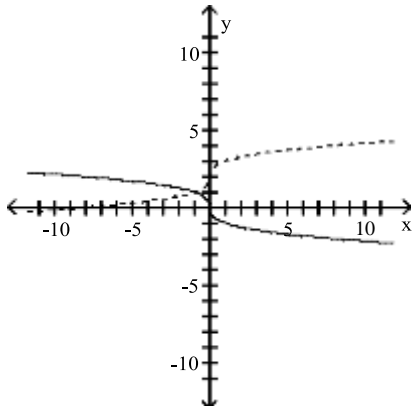

B)

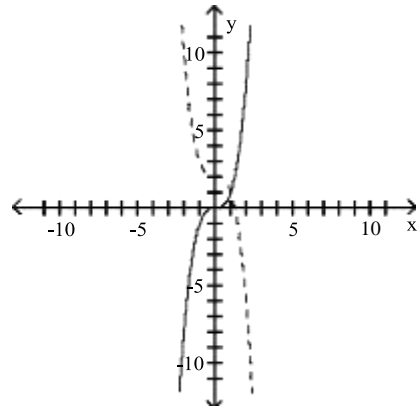

C)

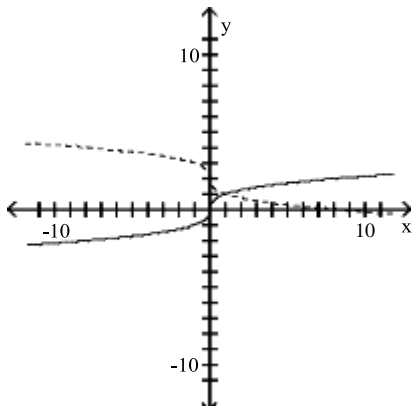

D)

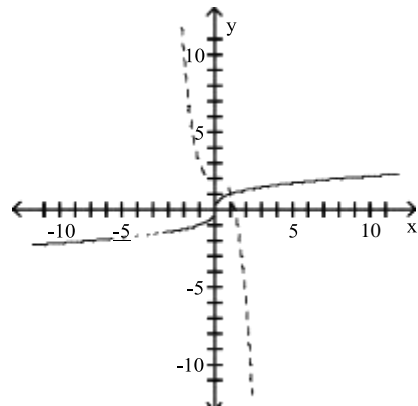

Answer: C

Fill in each blank with the appropriate response.

147) The graph of $y = -4|x|$ can be obtained from the graph of $y = |x|$ by vertically stretching by a factor of ___ and reflecting across the ___-axis.

A) 4; x

B) -4; y

C) 4; y

D) -4; x

Answer: A

148) The graph of $y = -6x^2$ can be obtained from the graph of $y = x^2$ by vertically stretching by a factor of ___ and reflecting across the ___-axis.

A) 6; x

B) -6; y

C) -6; x

D) 6; y

Answer: A

- 149) The graph of $y = -5(x - 3)^2 + 7$ can be obtained from the graph of $y = x^2$ by shifting horizontally ___ units to the _____, vertically stretching by a factor of ___, reflecting across the ___-axis, and shifting vertically ___ units in the _____ direction.
- A) 3; right; 7; y; 5; downward
 B) 3; right; 5; x; 7; upward
 C) 3; right; 7; x; 5; upward
 D) 3; left; 5; x; 7; upward

Answer: B

- 150) The graph of $y = -6(x + 2)^2 - 8$ can be obtained from the graph of $y = x^2$ by shifting horizontally ___ units to the _____, vertically stretching by a factor of ___, reflecting across the ___-axis, and shifting vertically ___ units in the _____ direction.
- A) 2; left; 6; x; 8; downward
 B) 2; right; 6; x; 8; upward
 C) 2; left; 8; x; 6; downward
 D) 2; right; 6; x; 8; downward

Answer: A

- 151) The graph of $y = -\frac{1}{6}(x + 3)^2 - 8$ can be obtained from the graph of $y = x^2$ by shifting horizontally ___ units to the _____, vertically shrinking by a factor of ___, reflecting across the ___-axis, and shifting vertically ___ units in the _____ direction.
- A) 3; left; $\frac{1}{6}$; x; 8; downward
 B) 3; right; $\frac{1}{6}$; x; 8; upward
 C) 3; left; 8; x; $\frac{1}{6}$; downward
 D) 3; right; $\frac{1}{6}$; x; 8; downward

Answer: A

- 152) The graph of $y = -\frac{1}{3}|-x| + 2$ can be obtained from the graph of $y = x$ by reflecting across the ___-axis, vertically

shrinking by a factor of ___, reflecting across the ___-axis, and shifting vertically ___ units in the _____ direction.

- A) $y; \frac{1}{3}; x; 2; \text{upward}$
 B) $x; 2; y; \frac{1}{3}; \text{upward}$
 C) $x; \frac{1}{3}; x; 2; \text{upward}$
 D) $y; \frac{1}{3}; x; 2; \text{downward}$

Answer: A

Give the equation of the function whose graph is described.

- 153) The graph of $y = |x|$ is vertically stretched by a factor of 3, and the resulting graph is reflected across the x-axis.
- A) $y = -3|-x|$
 B) $y = -3|x|$
 C) $y = 3|-x|$
 D) $y = -|x + 3|$

Answer: B

- 154) The graph of $y = x^2$ is shifted 2 units to the right. This graph is then vertically stretched by a factor of 5 and reflected across the x-axis. Finally, the graph is shifted 8 units upward.
- A) $y = -5(x - 2)^2 + 8$
 B) $y = -5(x + 8)^2 + 2$
 C) $y = -5(x - 2)^2 - 8$
 D) $y = -5(x + 2)^2 + 8$

Answer: A

- 155) The graph of $y = x^2$ is shifted 4 units to the left. This graph is then vertically stretched by a factor of 6 and reflected across the x-axis. Finally, the graph is shifted 7 units downward.
- A) $y = -6(x - 4)^2 + 7$
 B) $y = -6(x - 4)^2 - 7$
 C) $y = -6(x + 4)^2 - 7$
 D) $y = -6(x + 7)^2 - 4$

Answer: C

156) The graph of $y = x^2$ is shifted 3 units to the left. This graph is then vertically shrunk by a factor of $\frac{1}{5}$ and

reflected across the x-axis. Finally, the graph is shifted 7 units downward.

A) $y = \frac{1}{5}(x - 3)^2 - 7$ B) $y = -\frac{1}{5}(x - 3)^2 + 7$ C) $y = -\frac{1}{5}(x + 3)^2 - 7$ D) $y = -\frac{1}{5}(x - 3)^2 - 7$

Answer: C

157) The graph of $y = |x|$ is reflected across the y-axis and vertically shrunk by a factor of $\frac{2}{3}$. This graph is then

reflected across the x-axis. Finally, the graph is shifted 2 units upward.

A) $y = \left| -x - \frac{2}{3} \right| + 2$ B) $y = \frac{2}{3}|x| + 2$ C) $y = -\frac{2}{3}|-x| + 2$ D) $y = \frac{2}{3}|x + 2|$

Answer: C

158) The graph of $y = x^3$ is shifted 4.9 units to the right and then vertically shrunk by a factor of 0.2.

A) $y = 0.2(x + 4.9)^3$ B) $y = 0.2x^3 + 4.9$ C) $y = 4.9(x - 0.2)^3$ D) $y = 0.2(x - 4.9)^3$

Answer: D

159) The graph of $y = |x|$ is vertically stretched by a factor of 4.9. This graph is then reflected across the x-axis. Finally, the graph is shifted 0.63 units downward.

A) $y = -4.9|x| - 0.63$ B) $y = 4.9|x| - 0.63$ C) $y = 4.9|x| - 0.63$ D) $y = 4.9|x - 0.63|$

Answer: A

160) The graph of $y = |x|$ is reflected across the y-axis. This graph is then vertically stretched by a factor of 6.2. Finally, the graph is shifted 4 units downward.

A) $y = -6.2|x| - 4$ B) $y = 6.2|-x| + 4$ C) $y = 6.2|-x| - 4$ D) $y = 6.2|-x| - 6.2$

Answer: C

161) The graph of $y = \sqrt[3]{x}$ is shifted 5.6 units to the left. This graph is then vertically stretched by a factor of 6.5. Finally, the graph is reflected across the x-axis.

A) $y = -6.5\sqrt[3]{x + 5.6}$ B) $y = -6.5\sqrt[3]{x - 5.6}$ C) $y = 6.5\sqrt[3]{x + 5.6}$ D) $y = -5.6\sqrt[3]{x + 6.5}$

Answer: A

The graph of the given function is drawn with a solid line. The graph of a function, $g(x)$, transformed from this one is drawn with a dashed line. Find a formula for $g(x)$.

162) $f(x) = |x|$

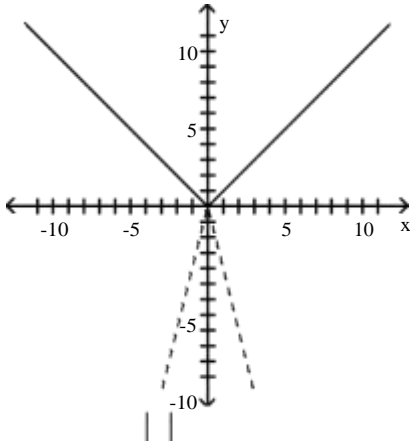

A) $g(x) = x - 4$

B) $g(x) = -4|x|$

C) $g(x) = |x - 4|$

D) $g(x) = |x + 4|$

Answer: B

163) $f(x) = x^2$

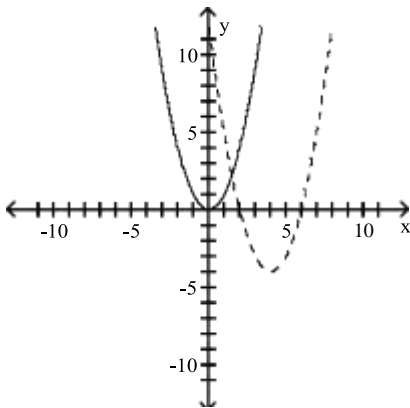

A) $g(x) = 6(x + 4)^2$

B) $g(x) = -6(x - 4)^2$

C) $g(x) = (x - 4)^2 - 4$

D) $g(x) = (x - 6)^2 - 4$

Answer: C

164) $f(x) = x^2$

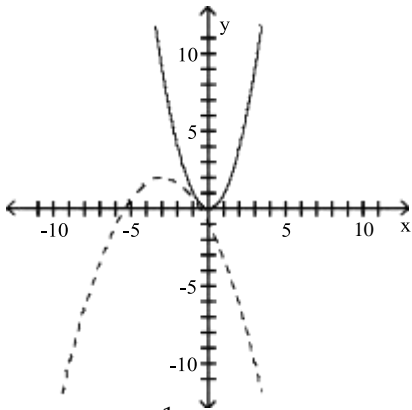

A) $g(x) = -\frac{1}{3}(x + 3)^2 + 2$

B) $g(x) = \frac{1}{3}(x - 3)^2 - 2$

C) $g(x) = -\frac{1}{3}(x + 3)^2$

D) $g(x) = (x + 3)^2 + 2$

Answer: A

165) $f(x) = |x|$

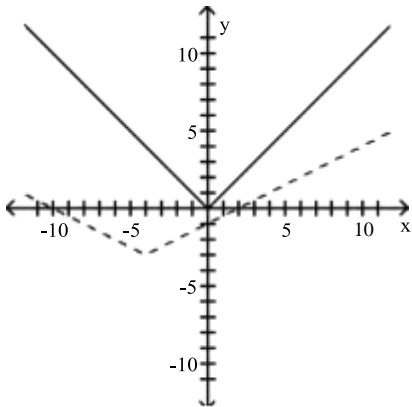

A) $g(x) = 3|x - 4| + 0.5$

B) $g(x) = 0.5|x - 4| + 3$

C) $g(x) = 3|x + 4| - 0.5$

D) $g(x) = 0.5|x + 4| - 3$

Answer: D

Use transformations to graph the function.

166) $f(x) = -2|x|$

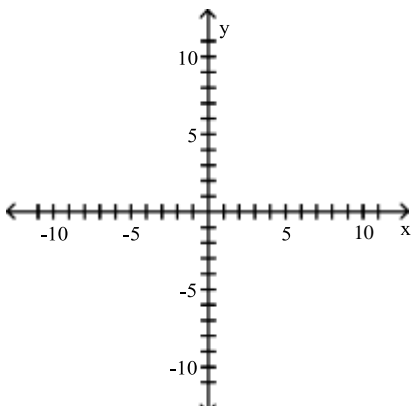

A)

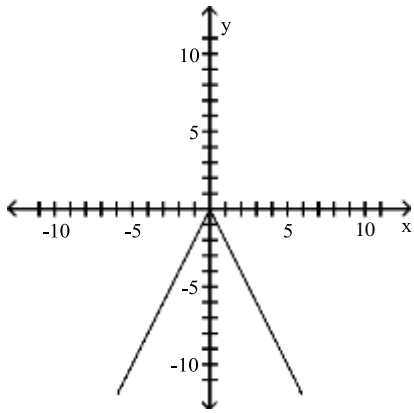

B)

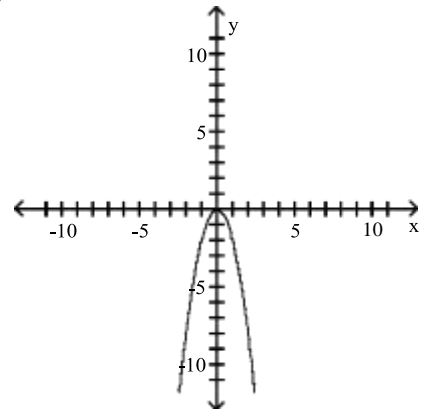

C)

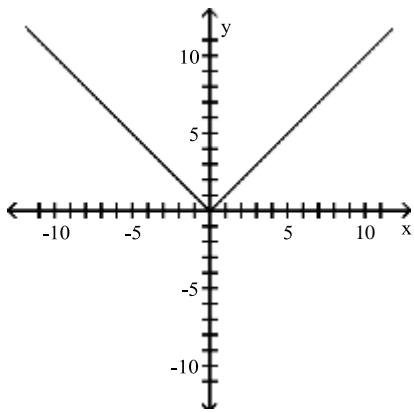

D)

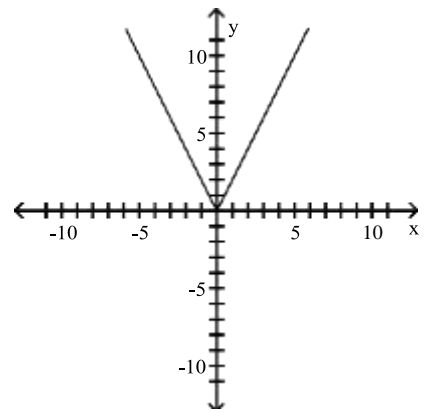

Answer: A

167) $f(x) = 3x^2 + 3$

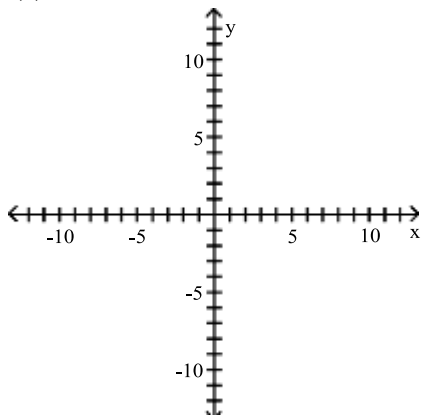

A)

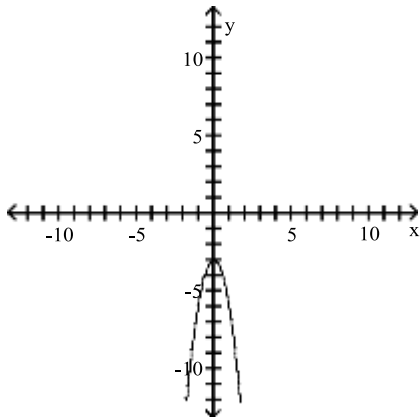

B)

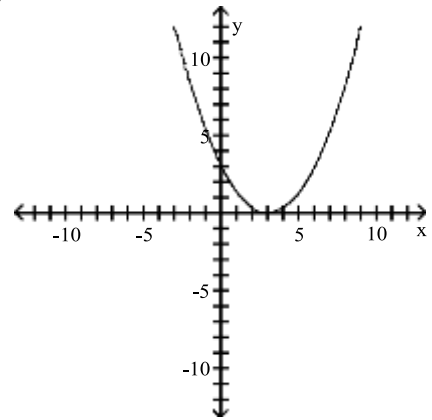

C)

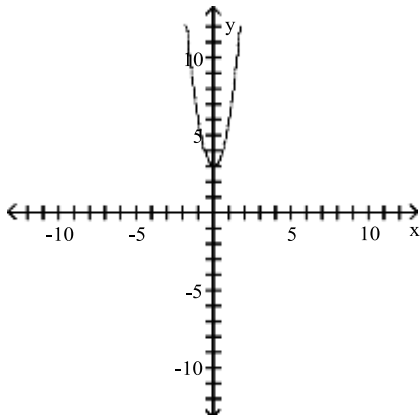

D)

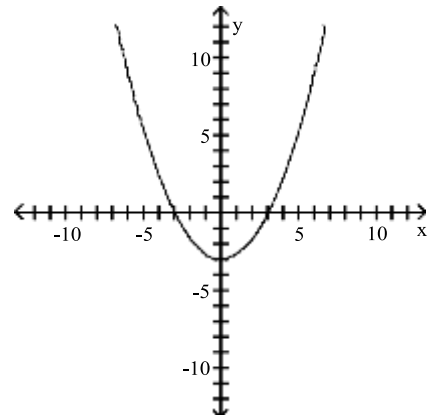

Answer: C

168) $f(x) = |9 - x|$

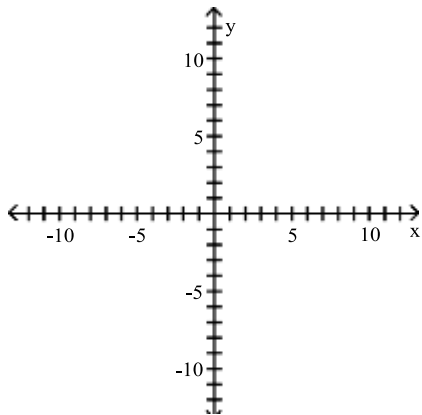

A)

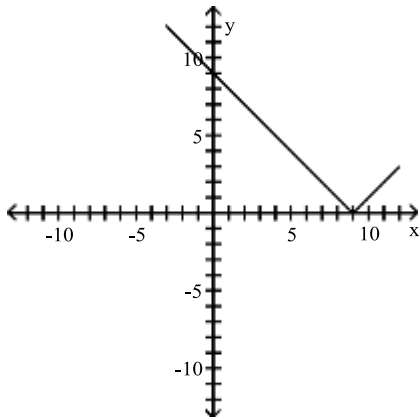

B)

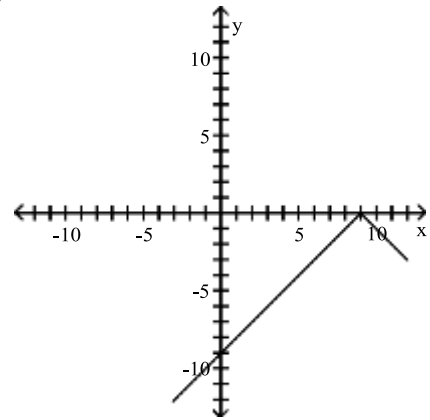

C)

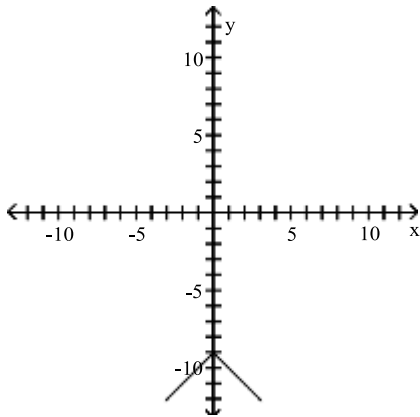

D)

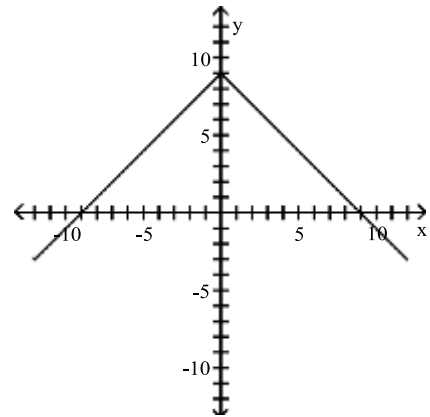

Answer: A

169) $f(x) = 5|x| - 6$

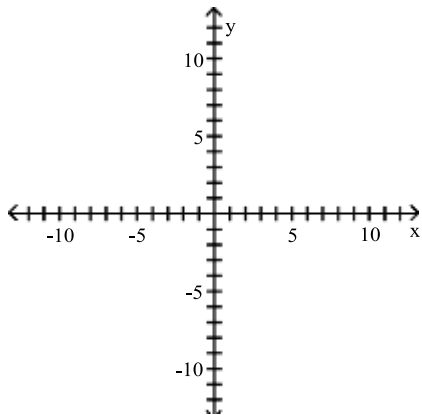

A)

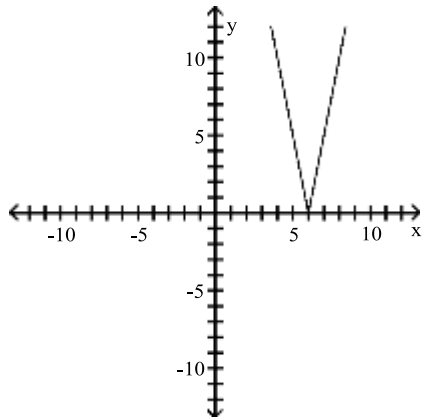

B)

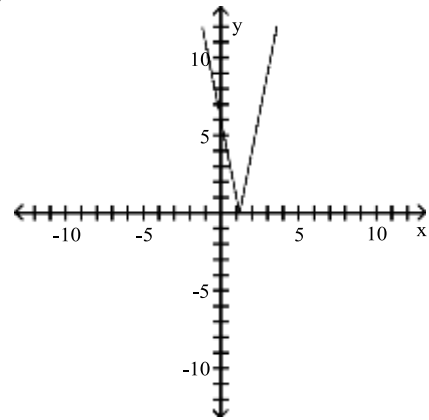

C)

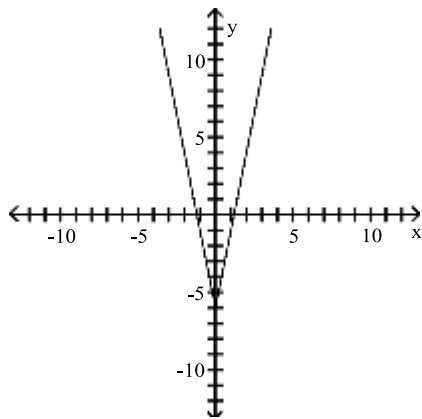

D)

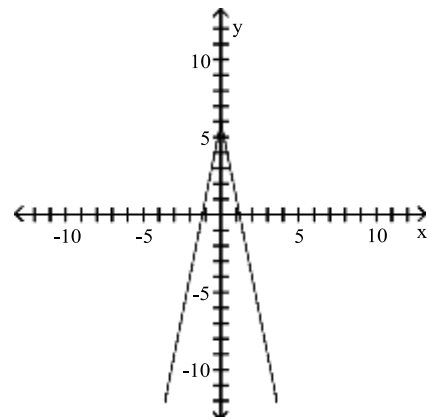

Answer: C

170) $f(x) = |x - 8| - 6$

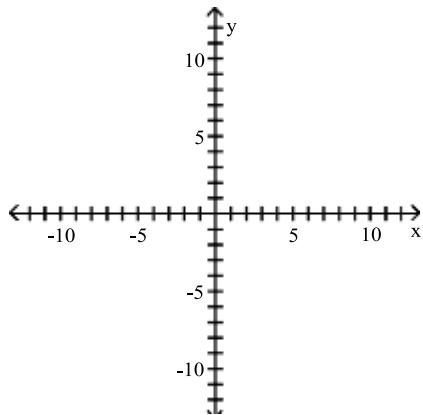

A)

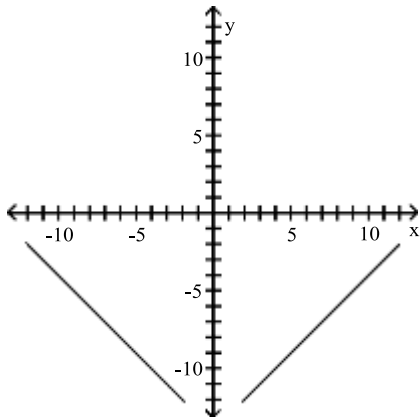

B)

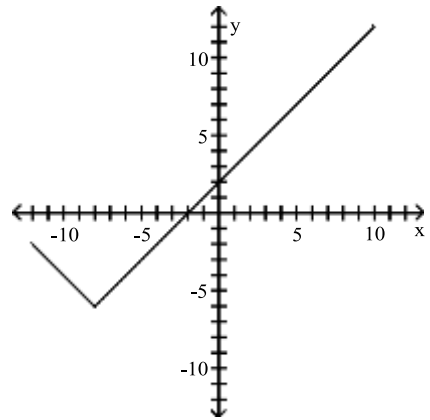

C)

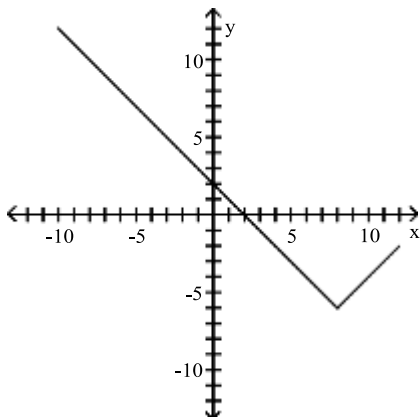

D)

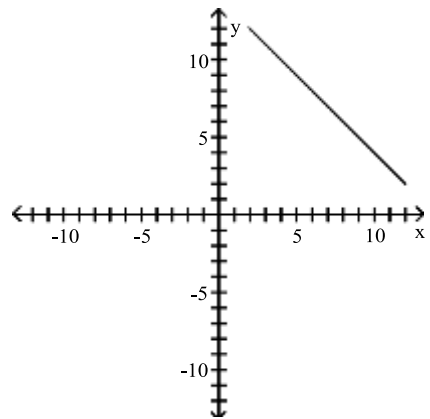

Answer: C

171) $f(x) = 4|x - 4| - 8$

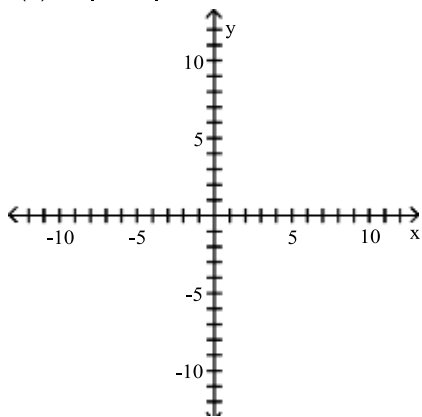

A)

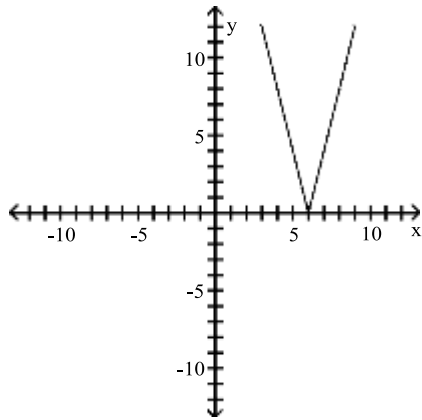

B)

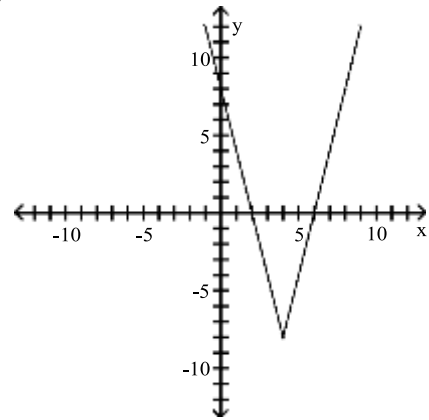

C)

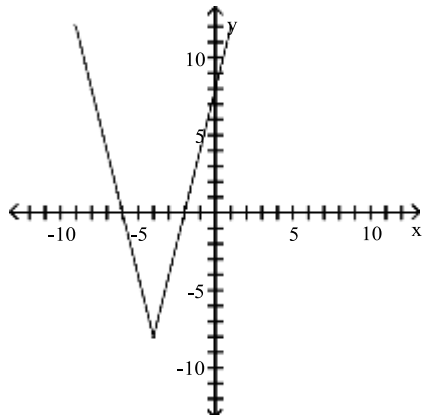

D)

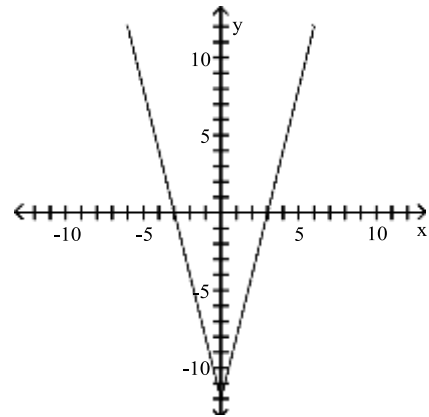

Answer: B

172) $f(x) = -\sqrt{x+2} + 1$

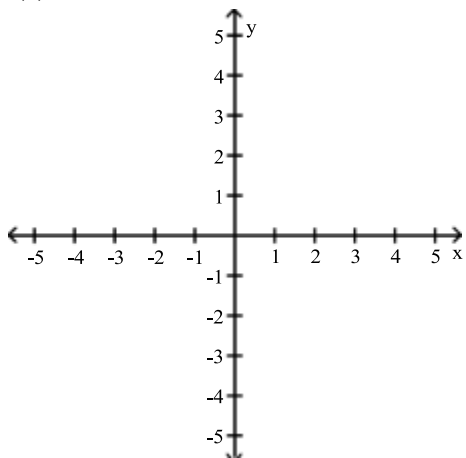

A)

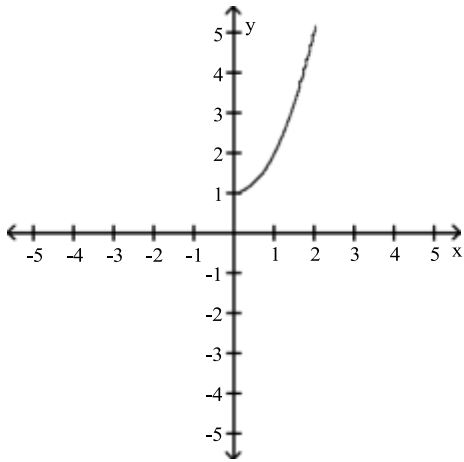

B)

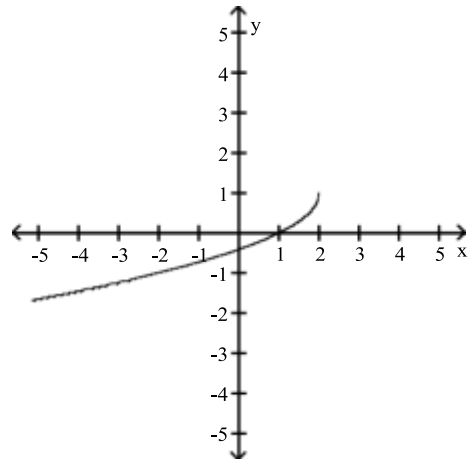

C)

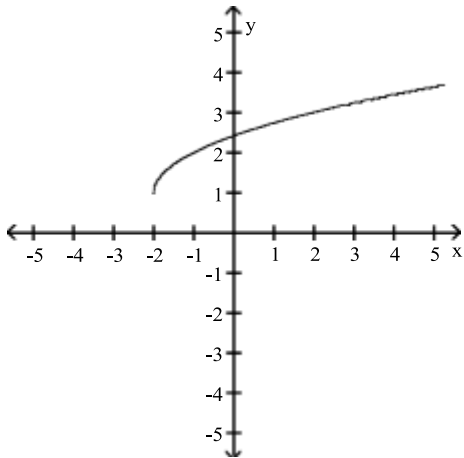

D)

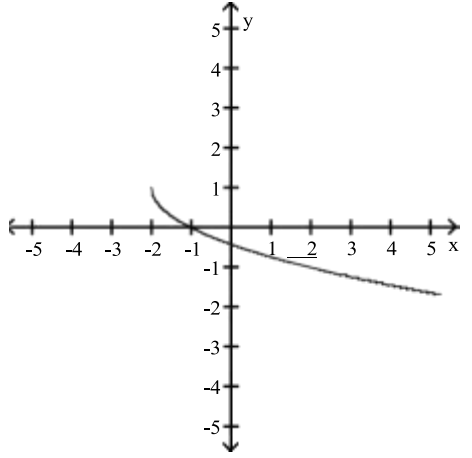

Answer: D

173) $f(x) = (x - 2)^2 - 4$

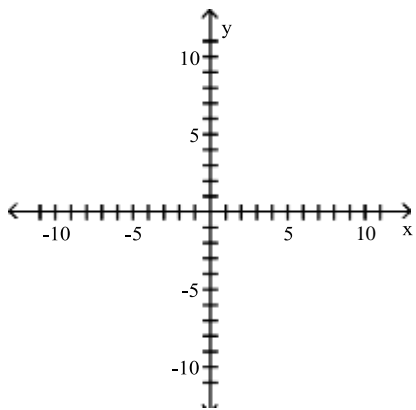

A)

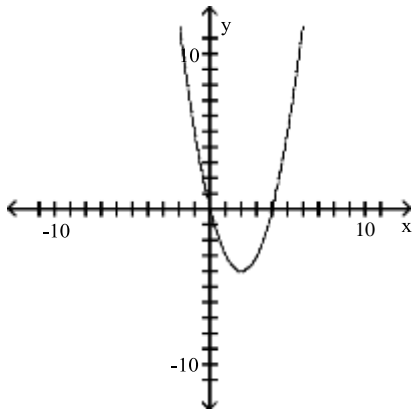

B)

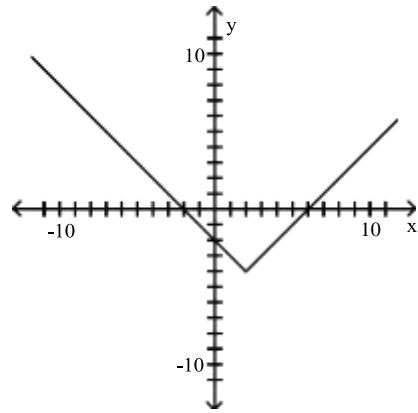

C)

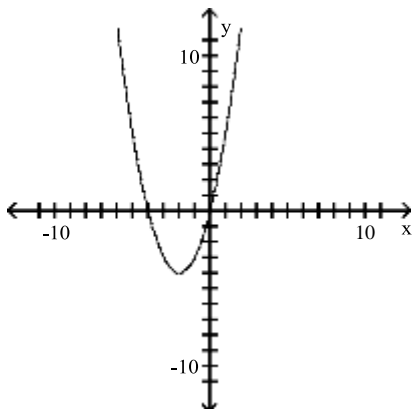

D)

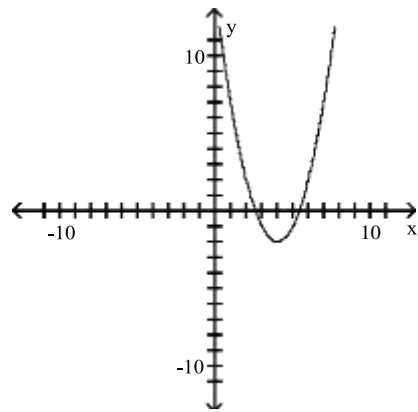

Answer: A

174) $f(x) = -3(x + 2)^2 + 4$

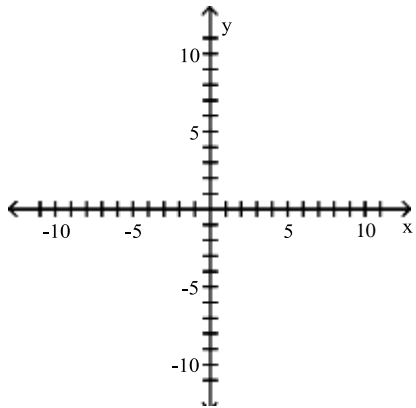

A)

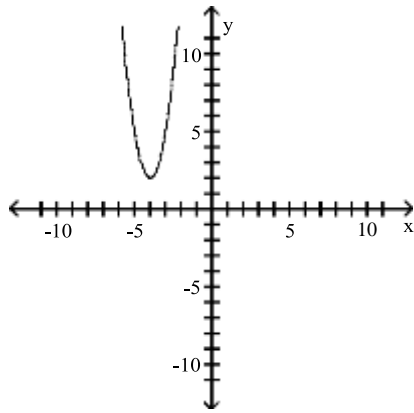

B)

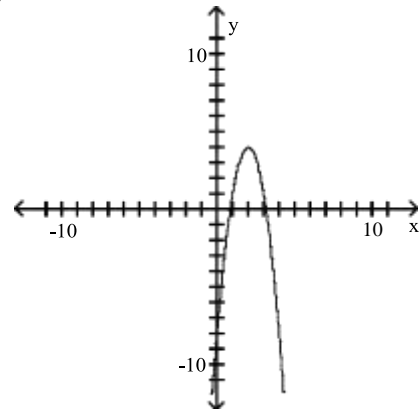

C)

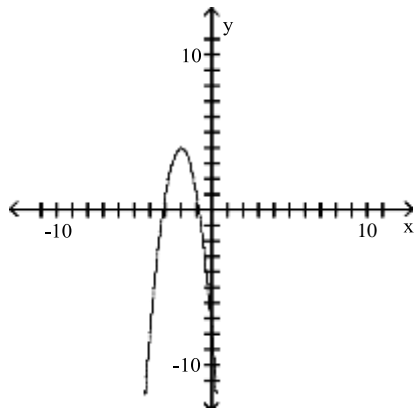

D)

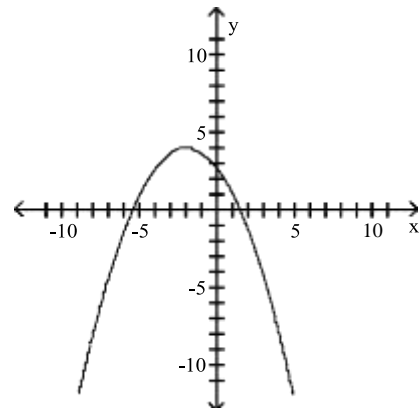

Answer: C

Use the accompanying graph of $y = f(x)$ to sketch the graph of the indicated function.

175) $y = -f(x)$

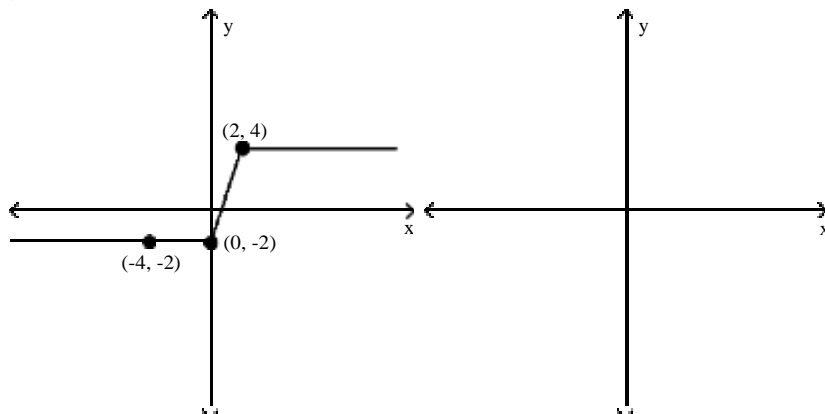

A)

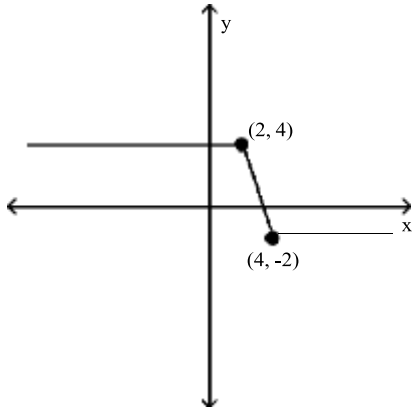

B)

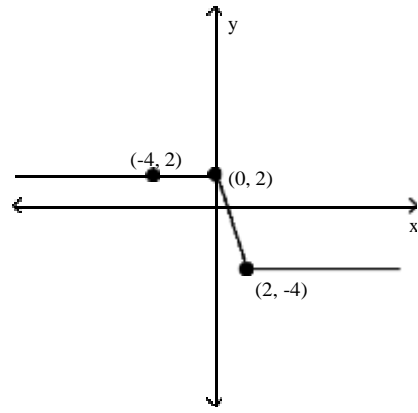

C)

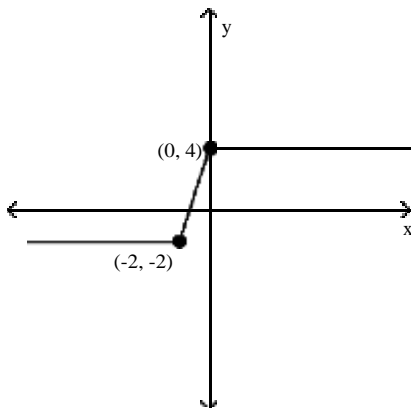

D)

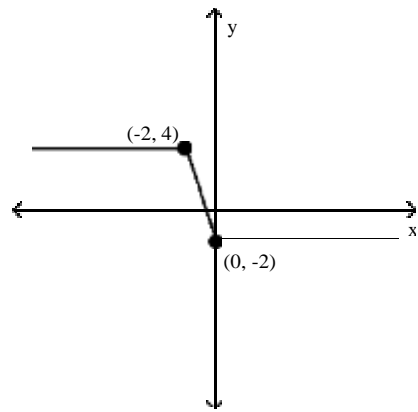

Answer: B

176) $y = f(-x)$

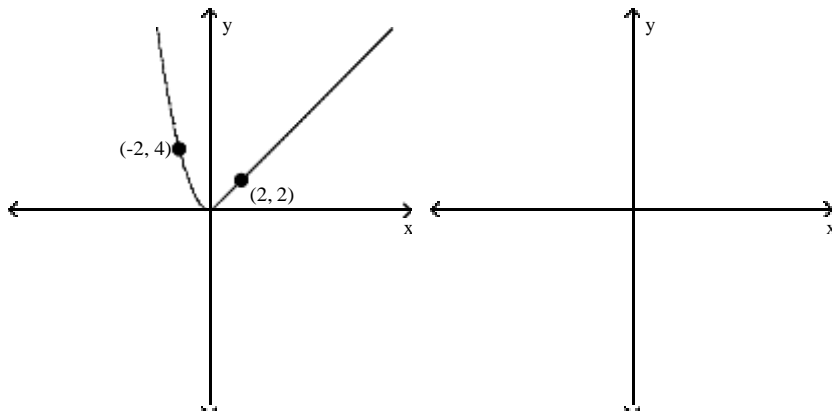

A)

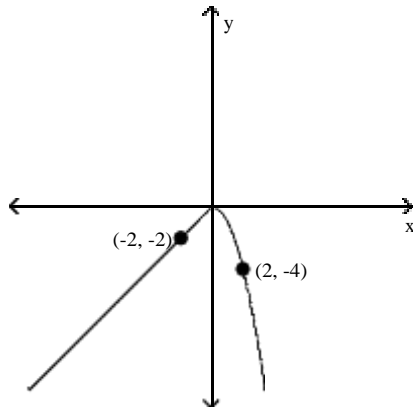

B)

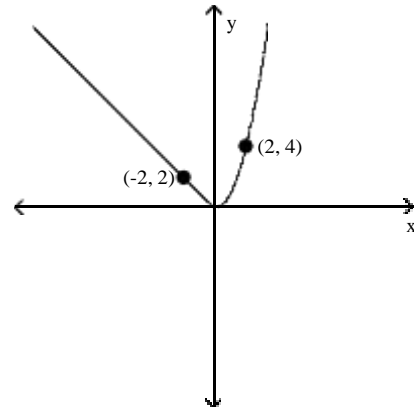

C)

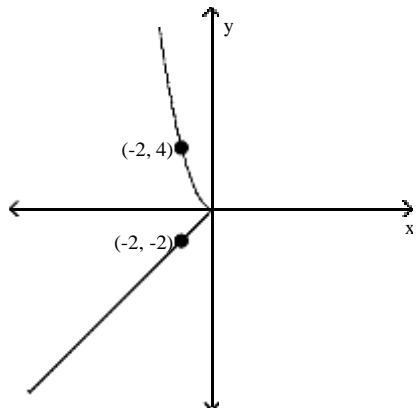

D)

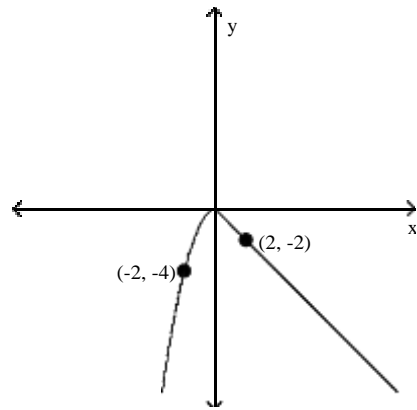

Answer: B

177) $y = f(-x)$

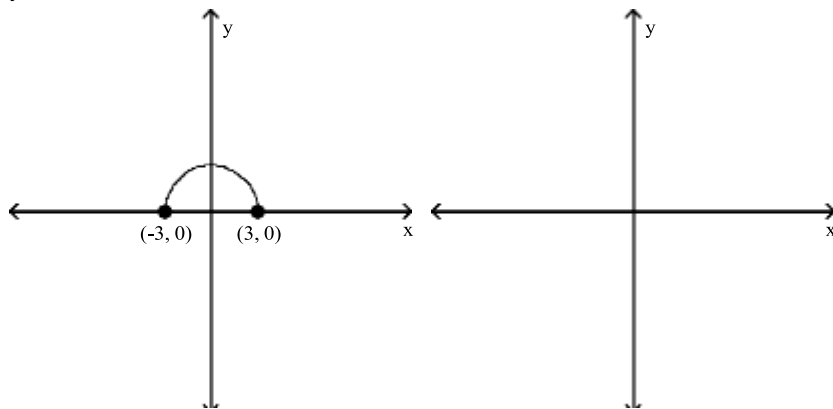

A)

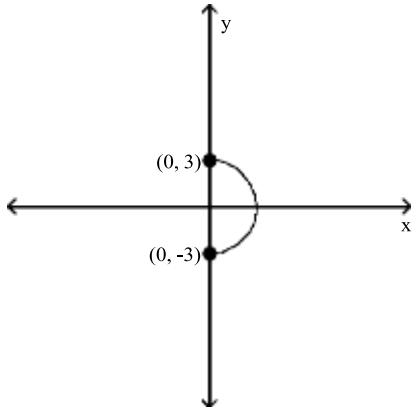

B)

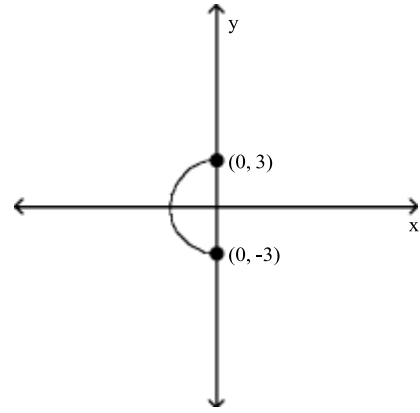

C)

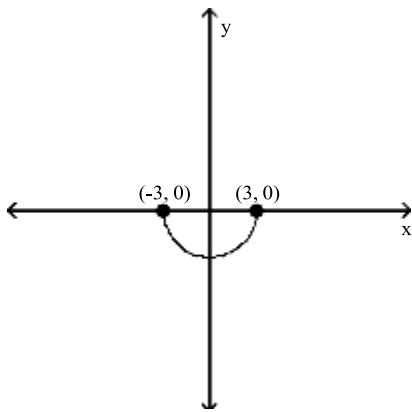

D)

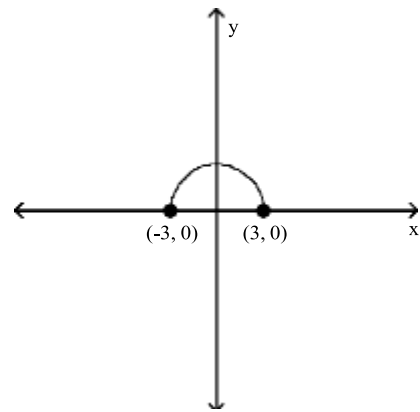

Answer: D

178) $y = -f(x)$

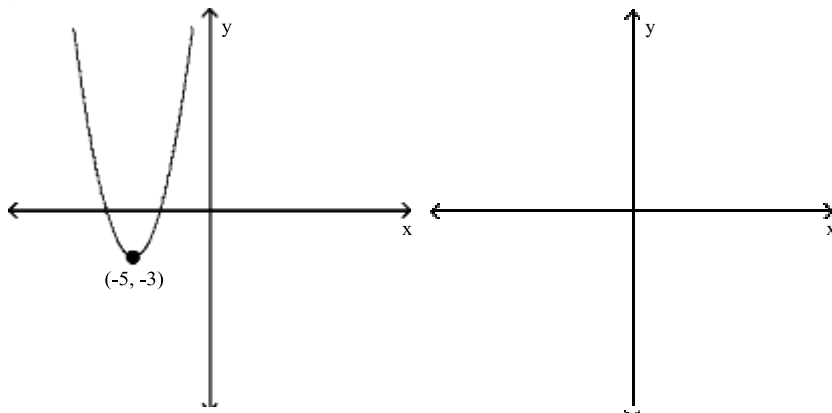

A)

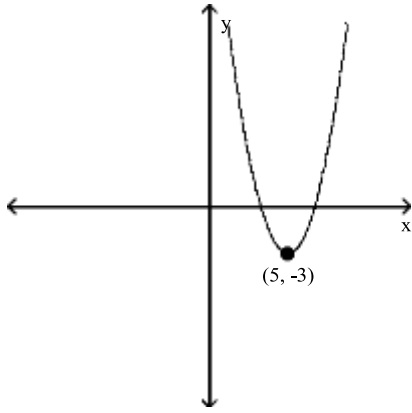

B)

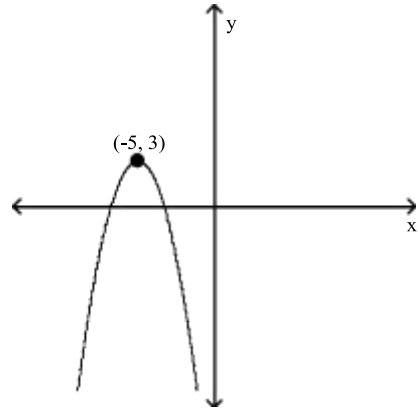

C)

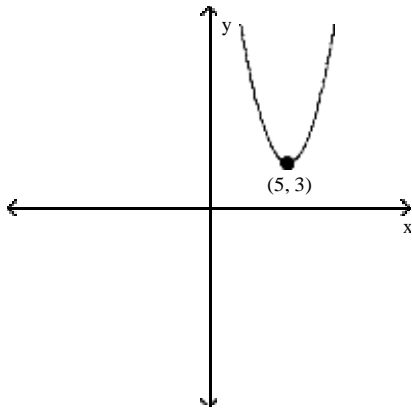

D)

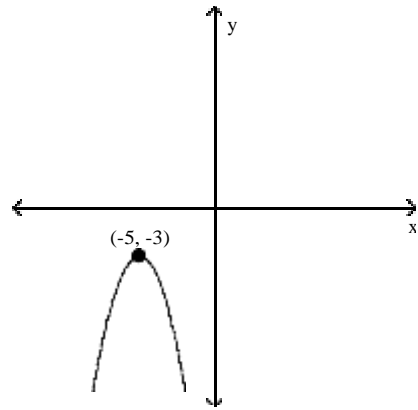

Answer: B

179) $y = 2f(x)$

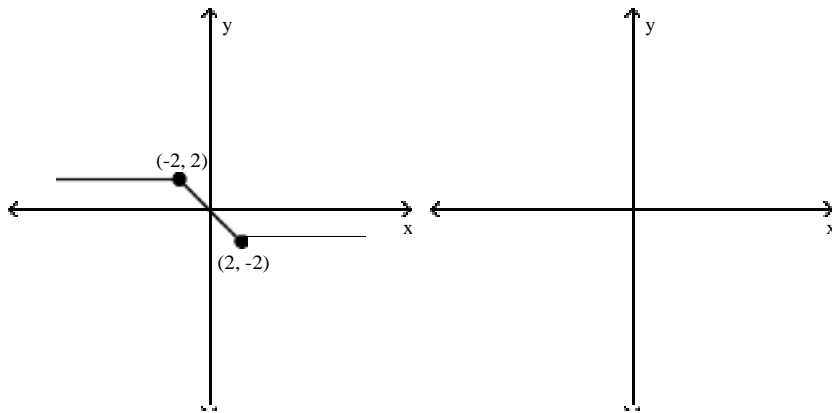

A)

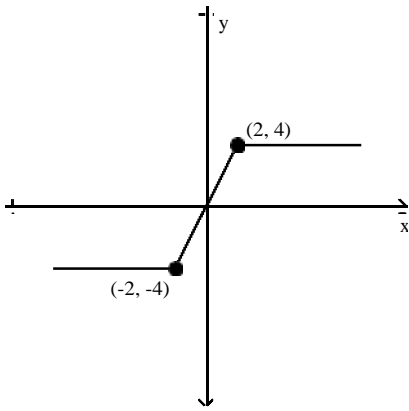

B)

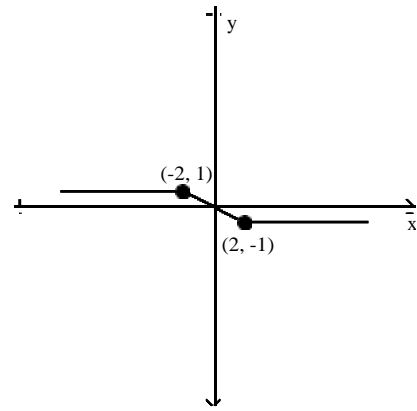

C)

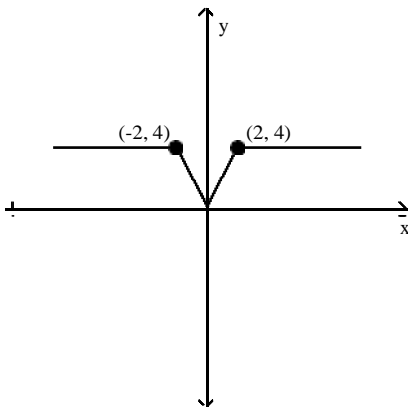

D)

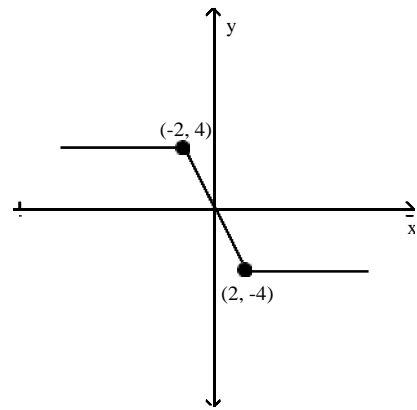

Answer: D

180) $y = -\frac{1}{2}f(x)$

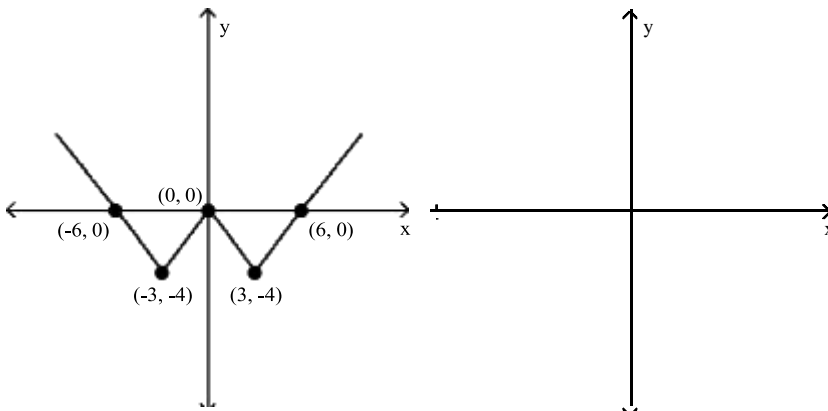

A)

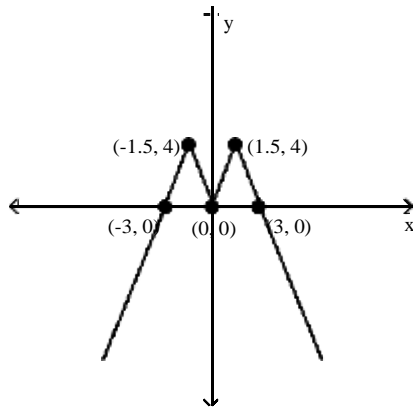

B)

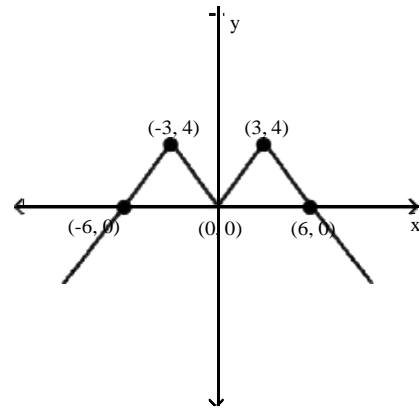

C)

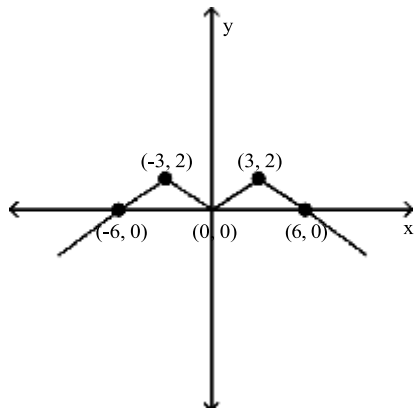

D)

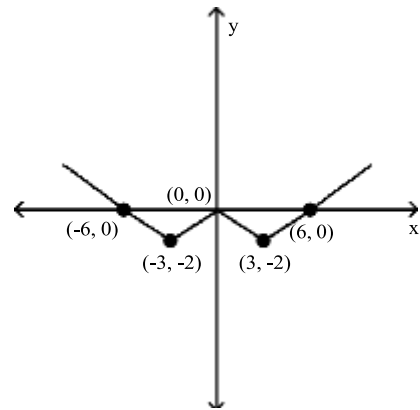

Answer: C

181) $y = -f(2x)$

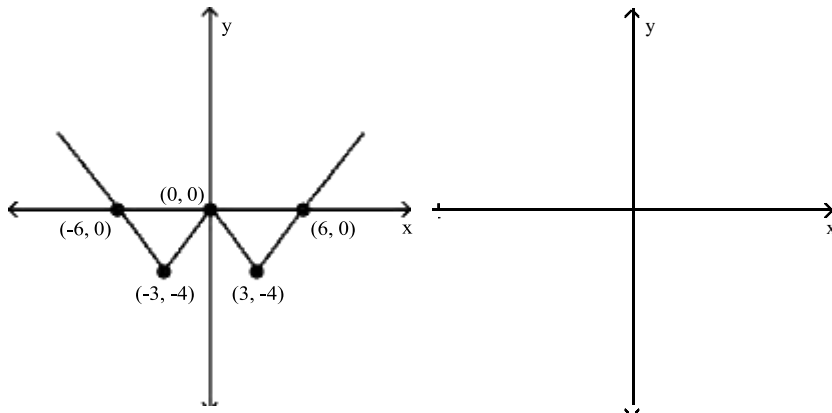

A)

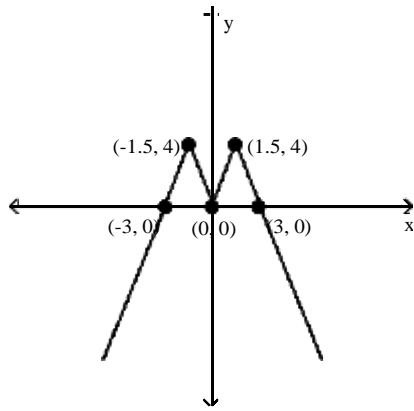

B)

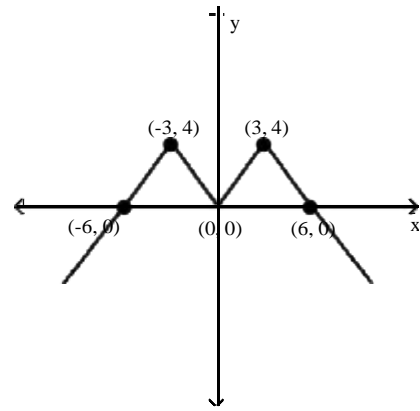

C)

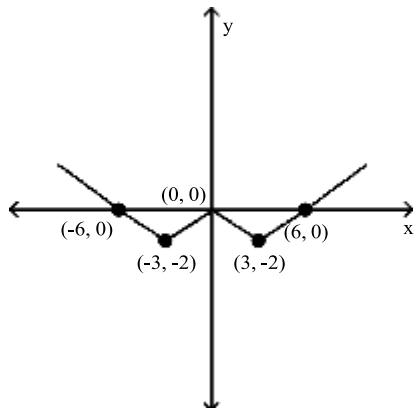

D)

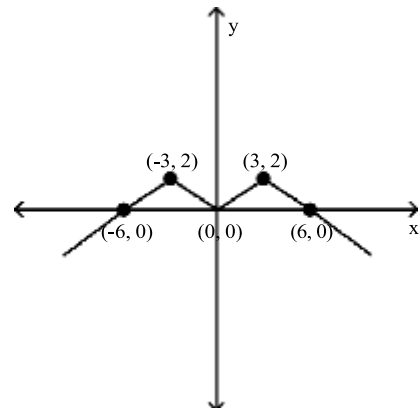

Answer: A

182) $y = f(x - 3)$

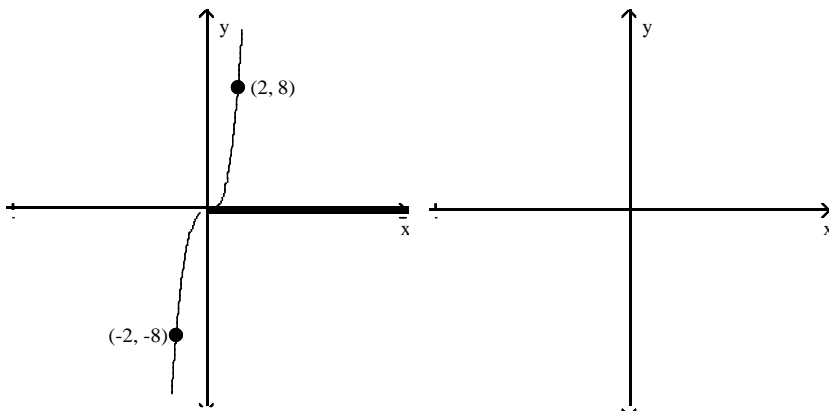

A)

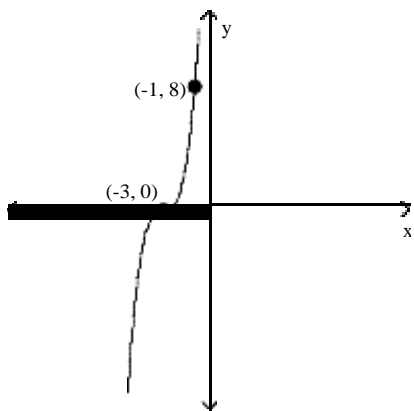

B)

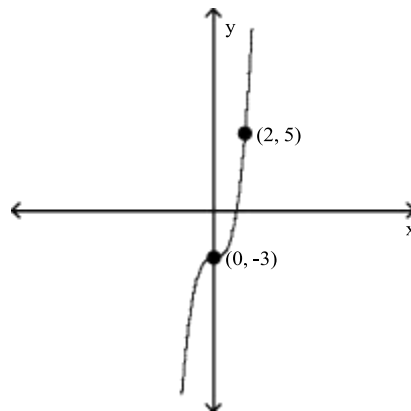

C)

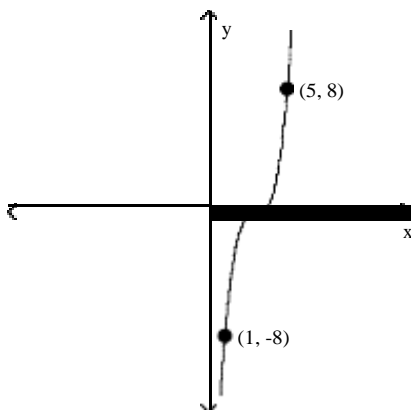

D)

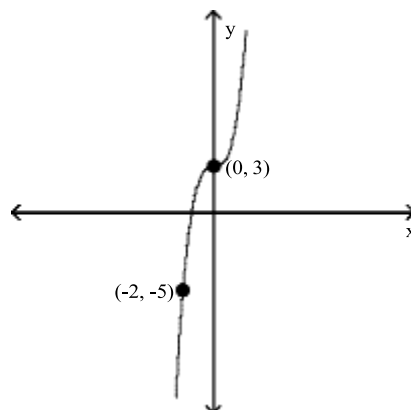

Answer: C

183) $y = -\frac{1}{3}f(x + 3) + 2$

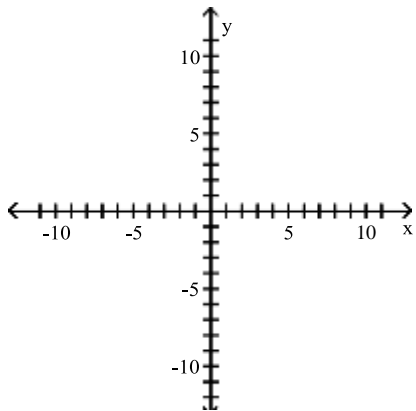
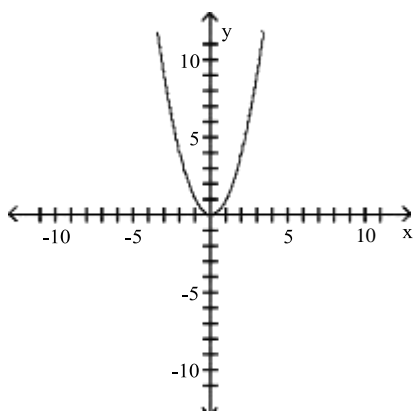

A)

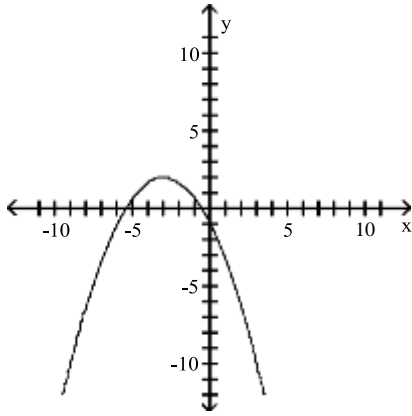

C)

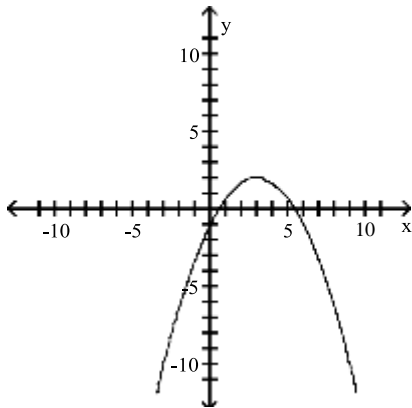

B)

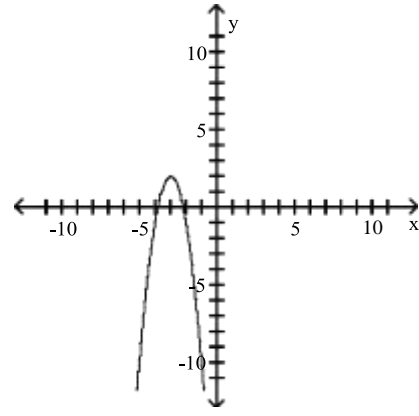

D)

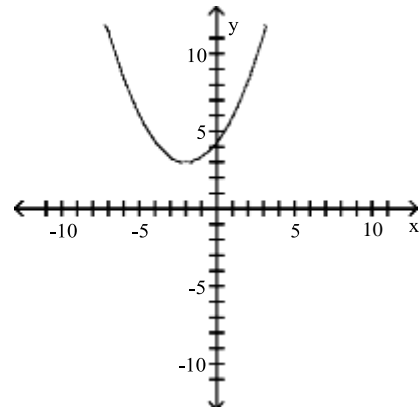

Answer: A

Let f be a function with the given domain and range. Find the domain and range of the indicated function.

184) Domain of $f(x)$: $[5, 10]$; Range of $f(x)$: $[0, 1]$

$-f(x)$

A) D: $[-10, -5]$; R: $[-1, 0]$

B) D: $[5, 10]$; R: $[0, 1]$

C) D: $[-10, -5]$; R: $[0, 1]$

D) D: $[5, 10]$; R: $[-1, 0]$

Answer: D

185) Domain of $f(x)$: $[2, 7]$; Range of $f(x)$: $[0, 3]$

$f(-x)$

A) D: $[2, 7]$; R: $[0, 3]$

B) D: $[-7, -2]$; R: $[-3, 0]$

C) D: $[2, 7]$; R: $[-3, 0]$

D) D: $[-7, -2]$; R: $[0, 3]$

Answer: D

186) Domain of $f(x)$: $[4, 6]$; Range of $f(x)$: $[0, 5]$

$f(x - 2)$

A) D: $[2, 7]$; R: $[0, 5]$

B) D: $[4, 9]$; R: $[2, 7]$

C) D: $[4, 6]$; R: $[-2, 3]$

D) D: $[6, 8]$; R: $[0, 5]$

Answer: D

187) Domain of $f(x)$: $[-5, 6]$; Range of $f(x)$: $[0, 6]$

$f(x + 3) + 2$

A) D: $[-8, 3]$; R: $[-2, 4]$

B) D: $[-2, 9]$; R: $[2, 8]$

C) D: $[-8, 3]$; R: $[2, 8]$

D) D: $[-2, 9]$; R: $[-2, 4]$

Answer: C

188) Domain of $f(x)$: $[-6, 7]$; Range of $f(x)$: $[0, 1]$

$$3f(x + 1)$$

A) D: $[-7, 6]$; R: $[0, 3]$

B) D: $[-7, 6]$; R: $[3, 4]$

C) D: $[-5, 8]$; R: $[3, 4]$

D) D: $[-5, 8]$; R: $[0, 3]$

Answer: A

189) Domain of $f(x)$: $[-7, 0]$; Range of $f(x)$: $[0, 3]$

$$f(-2x)$$

A) D: $[0, 14]$; R: $[0, 3]$

B) D: $\left[0, \frac{7}{2}\right]$; R: $[0, 3]$

C) D: $[-7, 0]$; R: $\left[-\frac{3}{2}, 0\right]$

D) D: $[-7, 0]$; R: $[-6, 0]$

Answer: B

190) Domain of $f(x)$: $[-3, 0]$; Range of $f(x)$: $[0, 5]$

$$2f\left(\frac{1}{4}x\right)$$

A) D: $[-6, 0]$; R: $[0, 20]$

B) D: $\left[-\frac{3}{4}, 0\right]$; R: $\left[0, \frac{5}{2}\right]$

C) D: $\left[-\frac{3}{4}, 0\right]$; R: $[0, 10]$

D) D: $[-12, 0]$; R: $[0, 10]$

Answer: D

Determine the intervals on which the function is increasing, decreasing, and constant.

191)

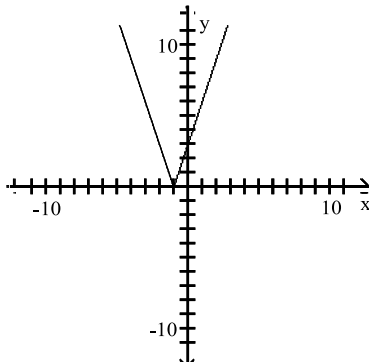

A) Increasing on $(-1, \infty)$; Decreasing on $(-\infty, -1)$

B) Increasing on $(-\infty, 1)$; Decreasing on $(1, \infty)$

C) Increasing on $(1, \infty)$; Decreasing on $(-\infty, 1)$

D) Increasing on $(-\infty, -1)$; Decreasing on $(-1, \infty)$

Answer: A

192)

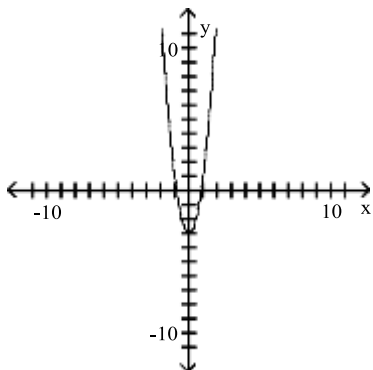

- A) Increasing on $(-\infty, 0)$; Decreasing on $(0, \infty)$
- C) Increasing on $(-\infty, 0)$; Decreasing on $(-\infty, 0)$

- B) Increasing on $(0, \infty)$; Decreasing on $(-\infty, 0)$
- D) Increasing on $(\infty, 0)$; Decreasing on $(0, -\infty)$

Answer: B

193)

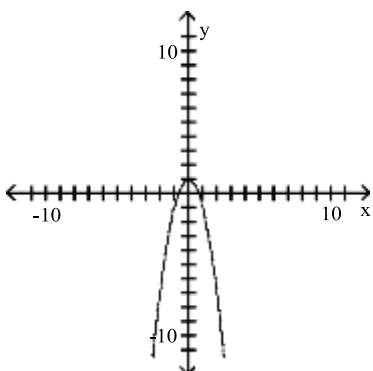

- A) Increasing on $(-\infty, 0)$; Decreasing on $(-\infty, 0)$
- C) Increasing on $(0, \infty)$; Decreasing on $(-\infty, 0)$

- B) Increasing on $(-\infty, 0)$; Decreasing on $(0, \infty)$
- D) Increasing on $(\infty, 0)$; Decreasing on $(0, -\infty)$

Answer: B

194)

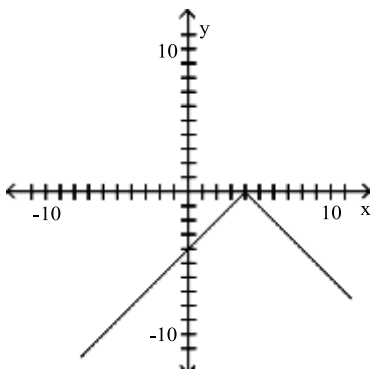

- A) Increasing on $(4, \infty)$; Decreasing on $(4, \infty)$
- C) Increasing on $(-\infty, 4)$; Decreasing on $(-\infty, 4)$

- B) Increasing on $(4, \infty)$; Decreasing on $(-\infty, 4)$
- D) Increasing on $(-\infty, 4)$; Decreasing on $(4, \infty)$

Answer: D

195)

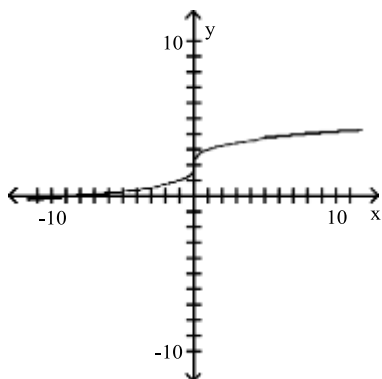

A) Decreasing on $(-\infty, \infty)$

C) Increasing on $(-\infty, 0)$; Decreasing on $(0, \infty)$

B) Increasing on $(0, \infty)$; Decreasing on $(-\infty, 0)$

D) Increasing on $(-\infty, \infty)$

Answer: D

196)

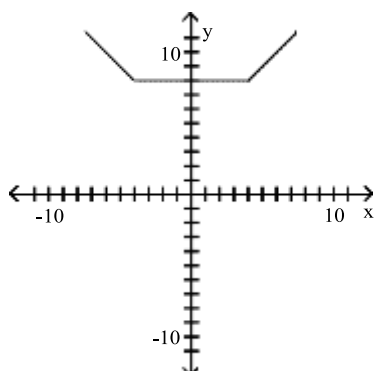

A) Increasing on $(4, \infty)$; Decreasing on $(-4, \infty)$; Constant on $(-4, 4)$

B) Increasing on $(-\infty, 4)$; Decreasing on $(-\infty, -4)$; Constant on $(4, \infty)$

C) Increasing on $(4, \infty)$; Decreasing on $(-\infty, -4)$; Constant on $(-4, 4)$

D) Increasing on $(-\infty, 4)$; Decreasing on $(-4, \infty)$; Constant on $(4, \infty)$

Answer: C

197)

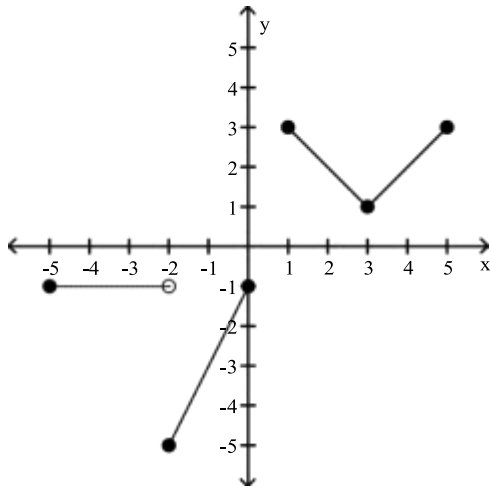

- A) Increasing on $(-1, 0)$ and $(3, 5)$; Decreasing on $(0, 3)$; Constant on $(-5, -3)$
- B) Increasing on $(-2, 0)$ and $(3, 4)$; Decreasing on $(-5, -2)$ and $(1, 3)$
- C) Increasing on $(1, 3)$; Decreasing on $(-2, 0)$ and $(3, 5)$; Constant on $(2, 5)$
- D) Increasing on $(-2, 0)$ and $(3, 5)$; Decreasing on $(1, 3)$; Constant on $(-5, -2)$

Answer: D

198)

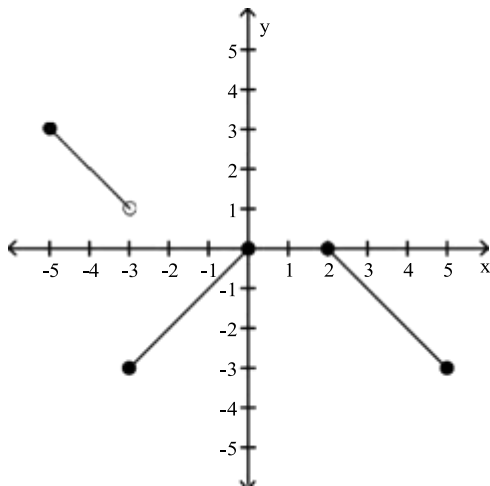

- A) Increasing on $(-3, -1)$; Decreasing on $(-5, -2)$ and $(2, 4)$; Constant on $(-1, 2)$
- B) Increasing on $(-5, -3)$ and $(2, 5)$; Decreasing on $(-3, 0)$; Constant on $(0, 2)$
- C) Increasing on $(-3, 0)$; Decreasing on $(-5, -3)$ and $(2, 5)$; Constant on $(0, 2)$
- D) Increasing on $(-3, 1)$; Decreasing on $(-5, -3)$ and $(0, 5)$; Constant on $(1, 2)$

Answer: C

Shown here are graphs of y_1 and y_2 . The point whose coordinates are given at the bottom of the screen lies on the graph of y_1 . Use this graph, and not your own calculator, to find the value of y_2 for the same value of x shown.

199)

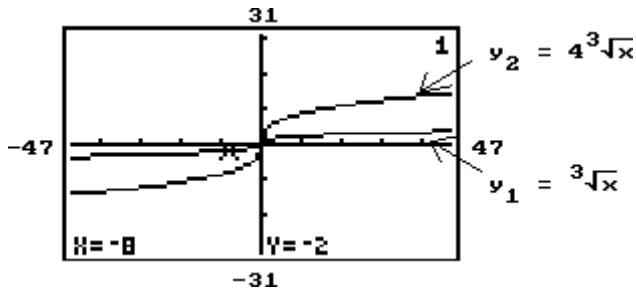

- A) -32 B) 2 C) -2 D) -8

Answer: D

200)

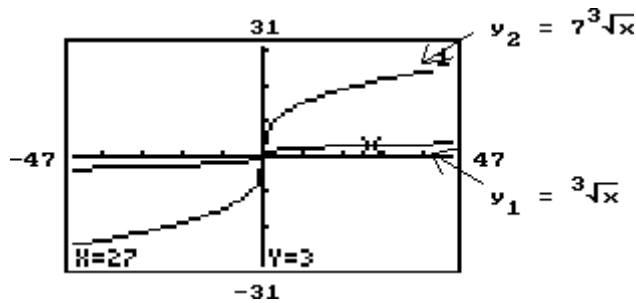

- A) 21 B) 2.3333333 C) 27 D) -2.3333333

Answer: A

201)

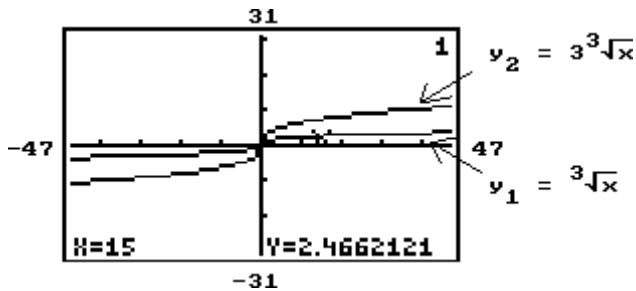

- A) 7.3986363 B) 0.8220707 C) -7.3986363 D) 14.797273

Answer: A

202)

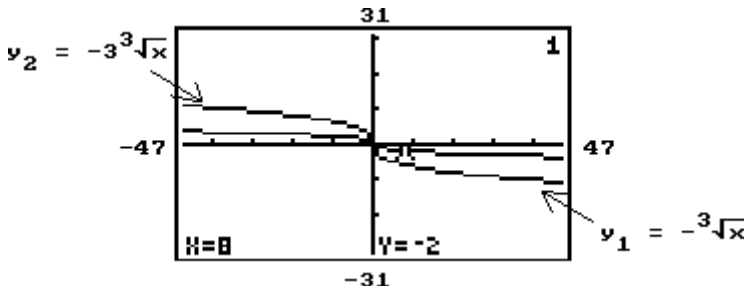

- A) -9 B) -6 C) 6 D) -1.5

Answer: B

203)

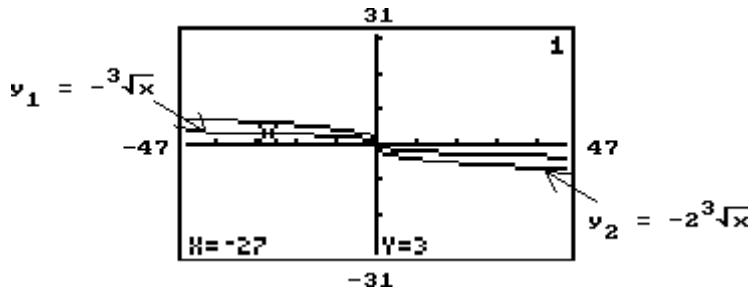

A) 0.6666666

B) -6

C) 6

D) 27

Answer: C

204)

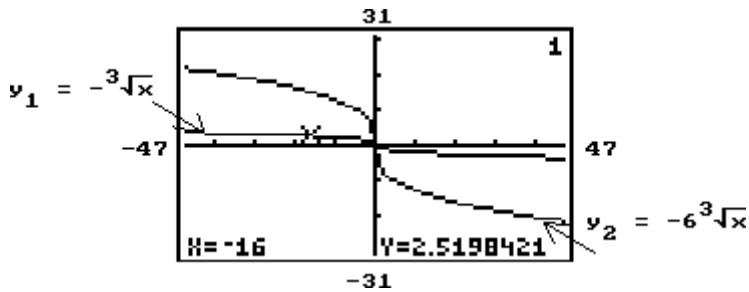

A) -15.119053

B) -16

C) 15.119053

D) 0.4199736

Answer: C

The figure shows a transformation of the graph of $y = x^2$. Write the equation for the graph.

205)

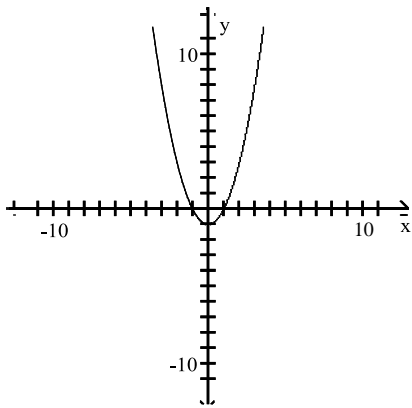

A) $g(x) = (x + 1)^2$

B) $g(x) = (x - 1)^2$

C) $g(x) = x^2 - 1$

D) $g(x) = (x - 1)^2 + 1$

Answer: C

206)

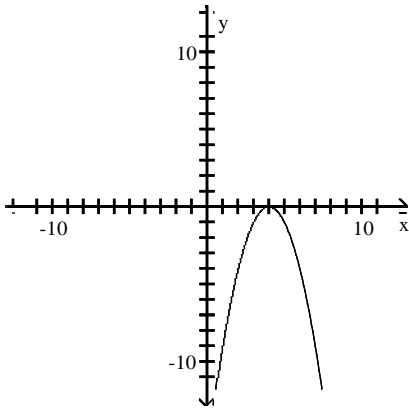

A) $g(x) = (x + 4)^2$

B) $g(x) = -x^2 - 4$

C) $g(x) = -x^2 + 4$

D) $g(x) = -(x - 4)^2$

Answer: D

207)

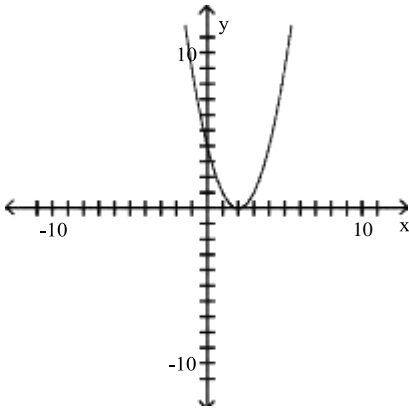

A) $g(x) = -x^2 + 2$

B) $g(x) = (-x - 2)^2$

C) $g(x) = (-x + 2)^2$

D) $g(x) = -x^2 - 2$

Answer: C

208)

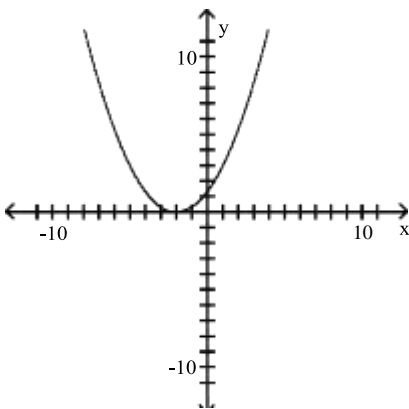

A) $g(x) = \frac{1}{3}(x + 2)^2$

B) $g(x) = (x - 2)^2$

C) $g(x) = \frac{1}{3}x^2 - 2$

D) $g(x) = \frac{1}{3}x^2 + 2$

Answer: A

209)

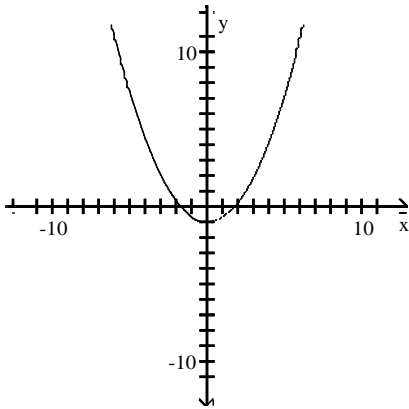

A) $g(x) = -x^2 + 3$

B) $g(x) = \frac{1}{3}(x - 3)^2$

C) $g(x) = \frac{1}{3}(x^2 - 3)$

D) $g(x) = \frac{1}{3}(x + 3)^2$

Answer: C

210)

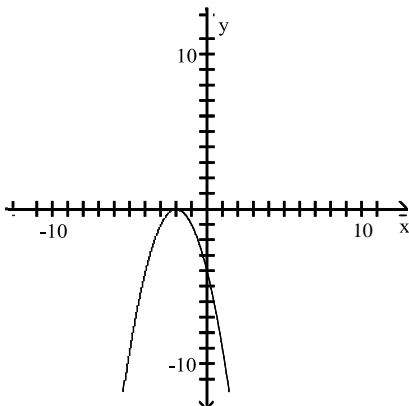

A) $g(x) = -x^2$

B) $g(x) = -(x + 2)^2$

C) $g(x) = -x^2 + 2$

D) $g(x) = -x^2 - 2$

Answer: B

Provide an appropriate response.

211) True or false? If r is an x -intercept of the graph of $y = f(x)$, then $y = f(-x)$ has an x -intercept at $x = r$.

A) True

B) False

Answer: B

212) True or false? If b is a y -intercept of the graph of $y = f(x)$, then $y = f(-x)$ has a y -intercept at $x = b$.

A) True

B) False

Answer: A

213) True or false? If the function $y = f(x)$ increases on the interval (a, b) of its domain, then $y = f(-x)$ increases on the interval (a, b) .

A) False

B) True

Answer: A

214) If b is a y -intercept of the graph of $y = f(x)$, then $y = -5f(x)$ has a y -intercept of which of these points?

A) b

B) $5b$

C) $-5b$

D) $-b$

Answer: C

215) True or false? If the function $y = f(x)$ increases on the interval (a, b) of its domain, and we are given that $c < 0$, then the graph of $y = cf(x)$ decreases on the interval (a, b) .

A) True

B) False

Answer: A

216) True or False. If the graph of $y = f(x)$ is symmetric with respect to the y -axis, then the graph of $y = -f(x)$ is not symmetric with respect to the y -axis.

A) False

B) True

Answer: A

217) True or False. If the graph of $y = f(x)$ is symmetric with respect to the origin, then the graph of $y = f(-x)$ is symmetric with respect to the origin.

A) True

B) False

Answer: A

The graph of the function $y = f(x)$ is given below. Sketch the graph of $y = |f(x)|$.

218)

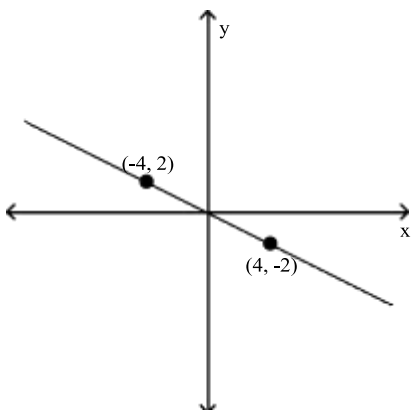

A)

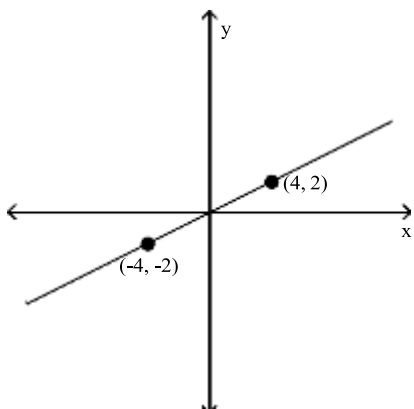

B)

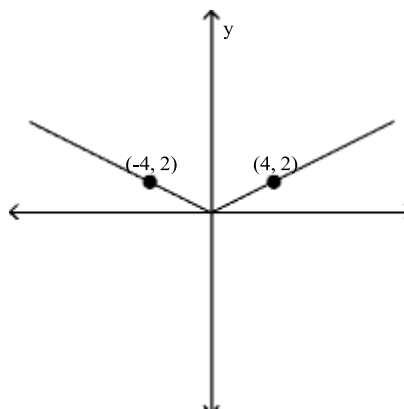

C)

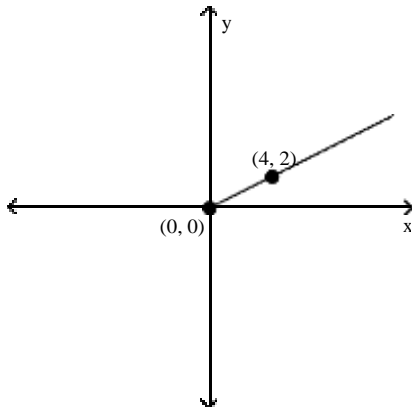

D)

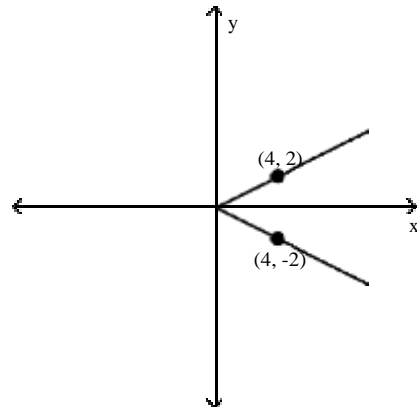

Answer: B

219)

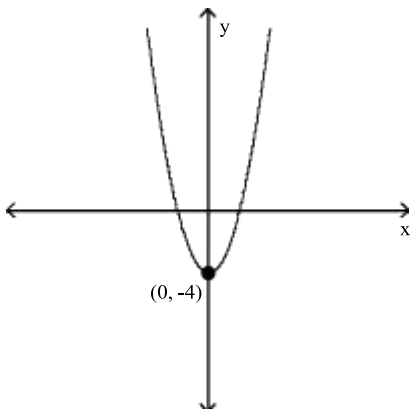

A)

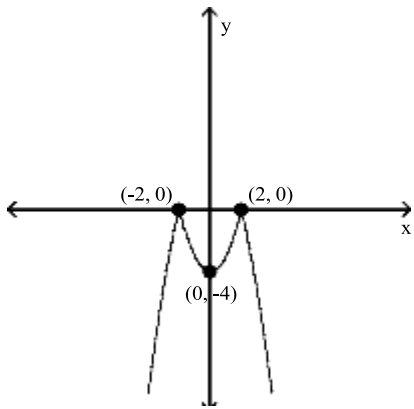

B)

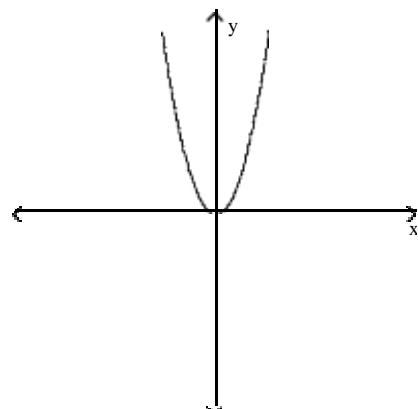

C)

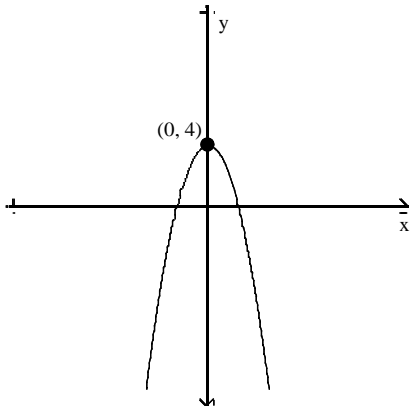

D)

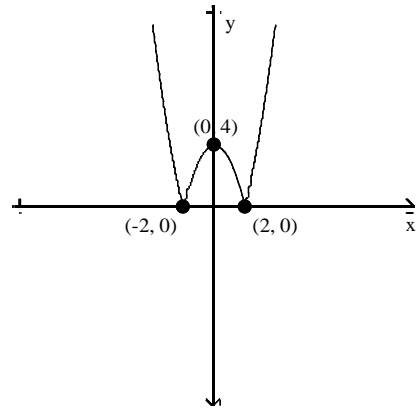

Answer: D

220)

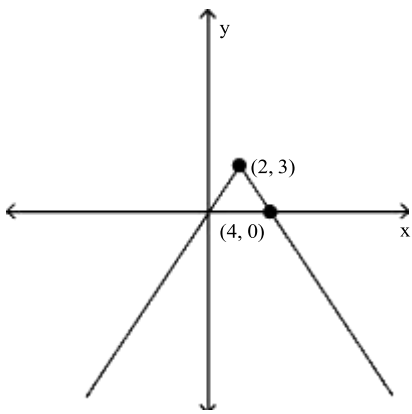

A)

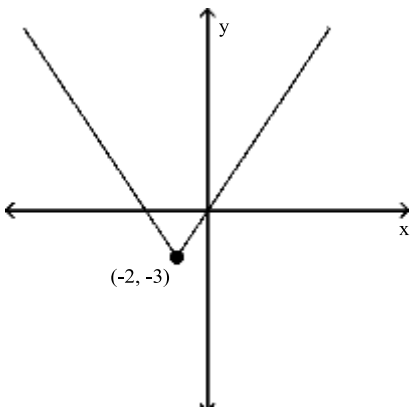

B)

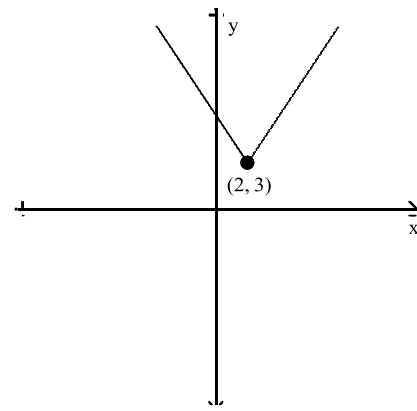

C)

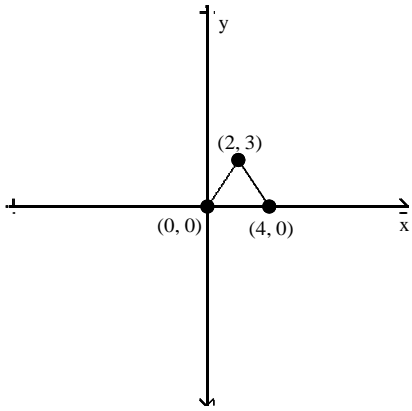

D)

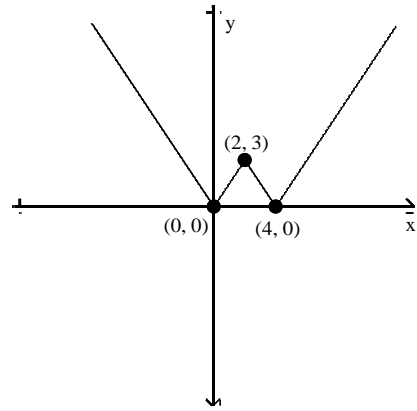

Answer: D

221)

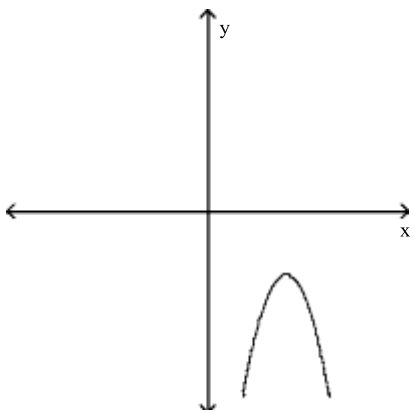

A)

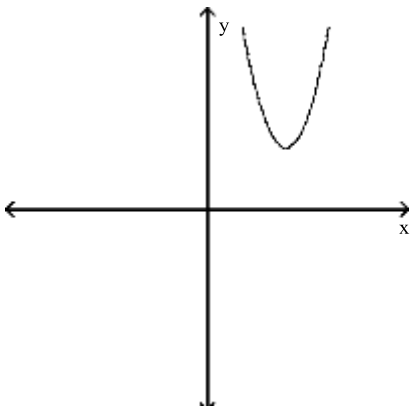

B)

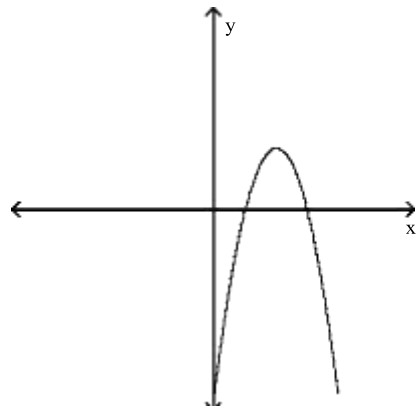

C)

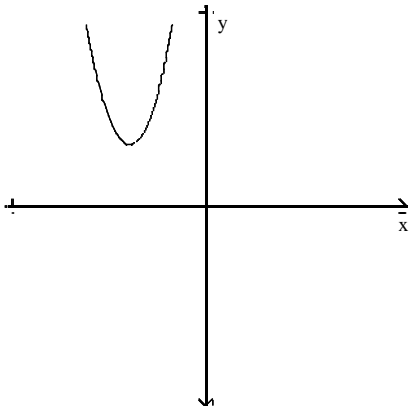

D)

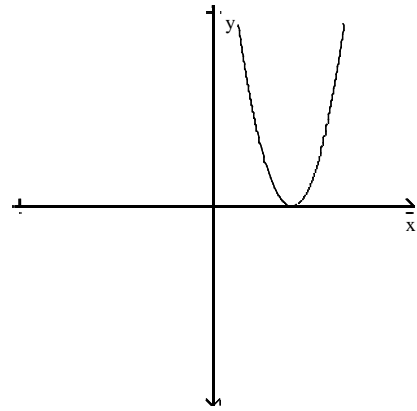

Answer: A

222)

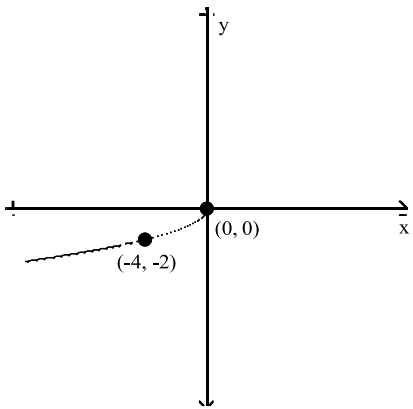

A)

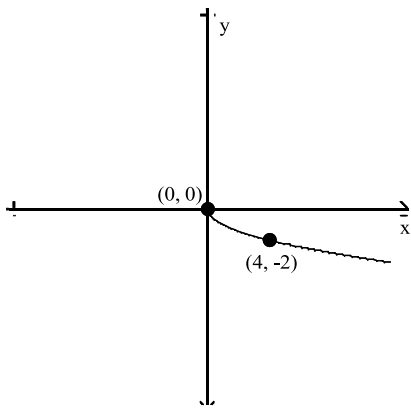

B)

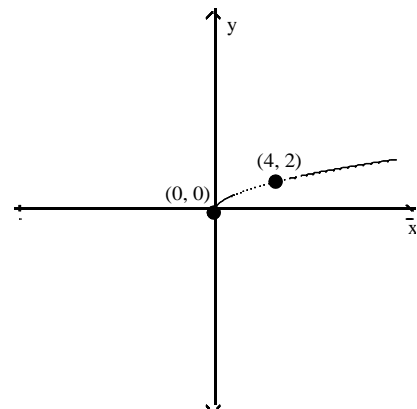

C)

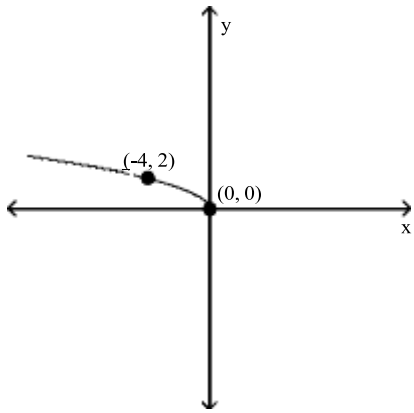

D)

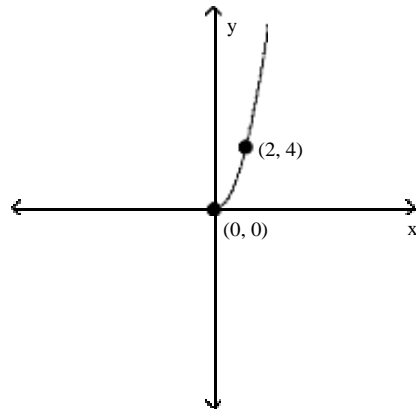

Answer: C

223)

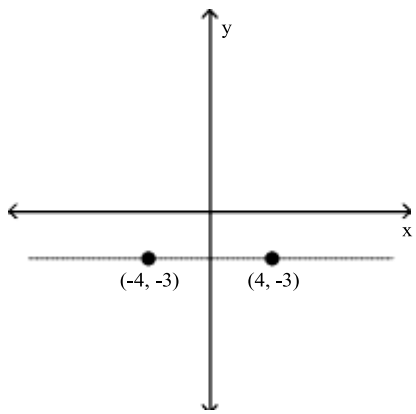

A)

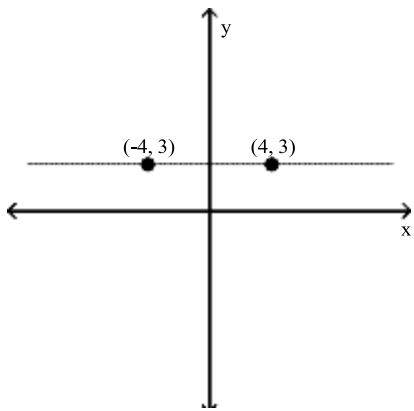

B)

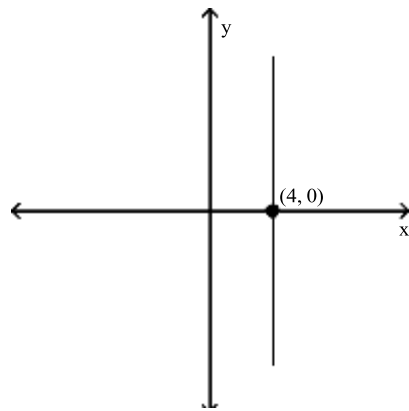

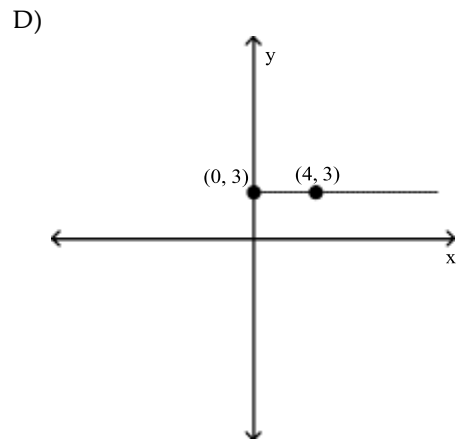
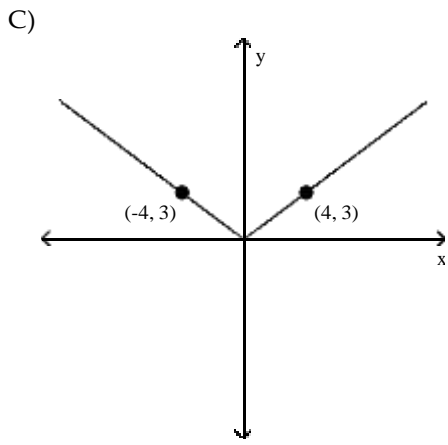

Answer: A

224)

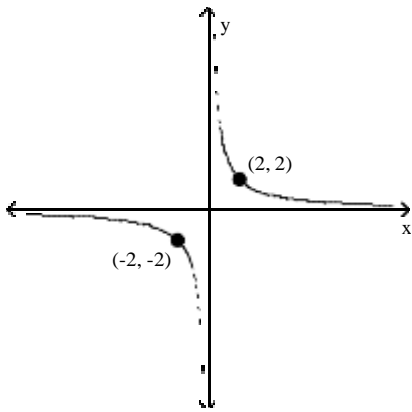

A)

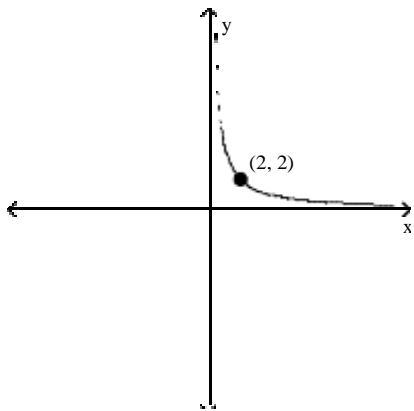

B)

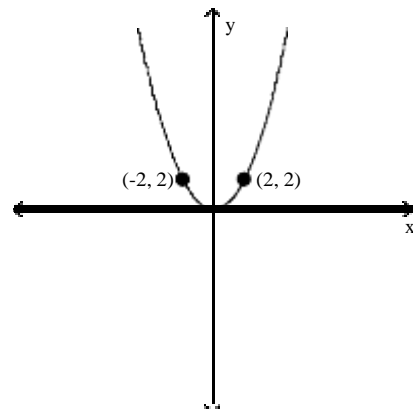

C)

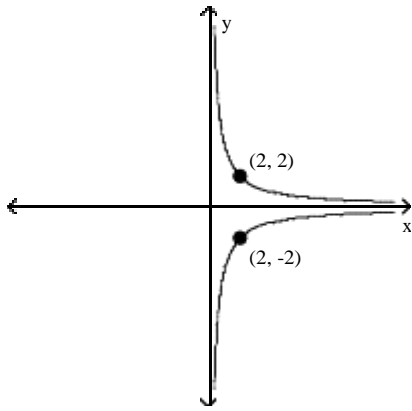

D)

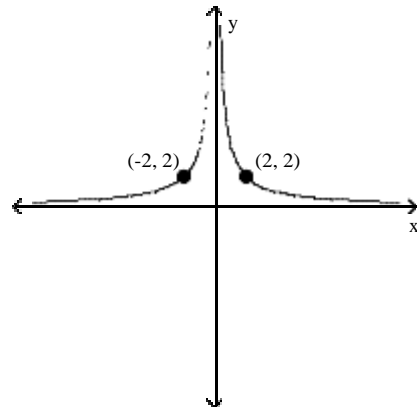

Answer: D

225)

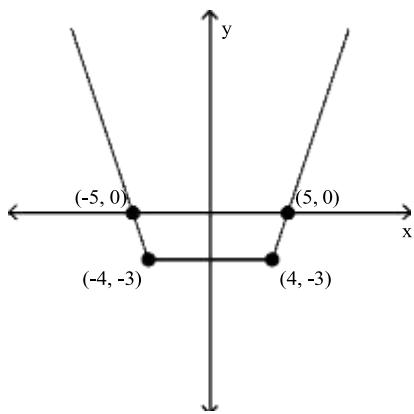

A)

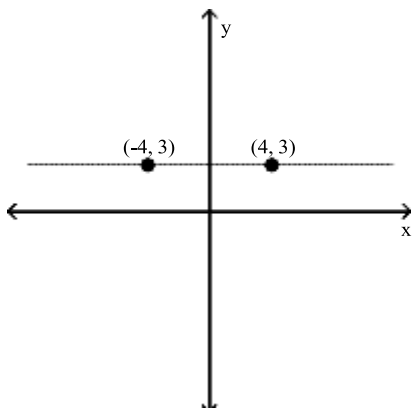

B)

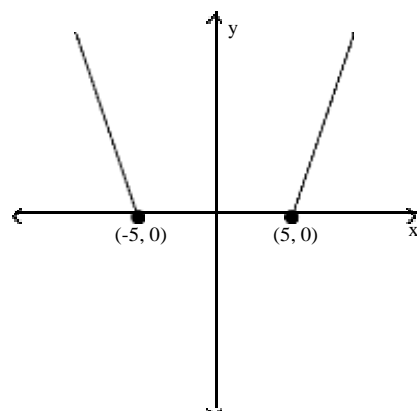

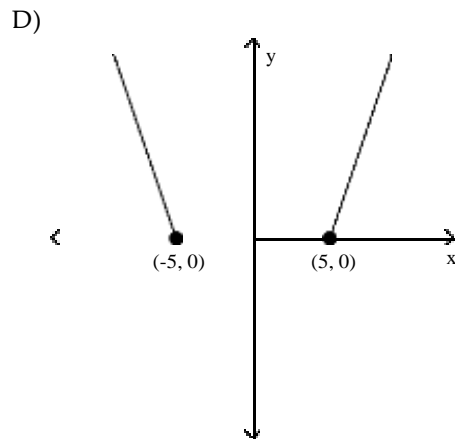
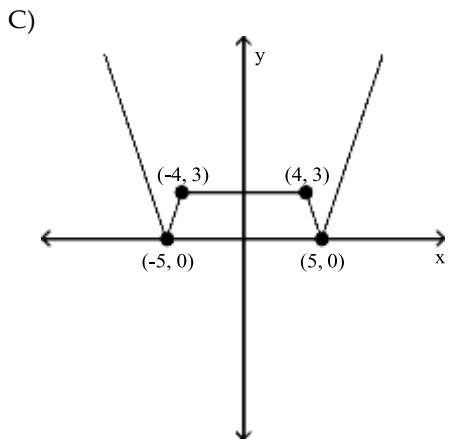

Answer: C

226)

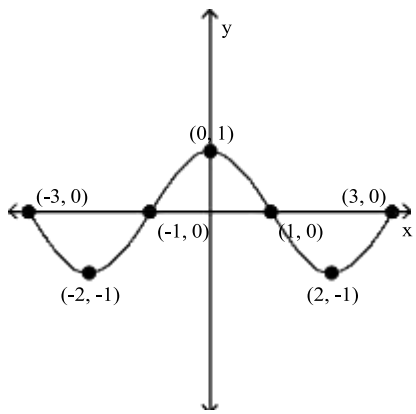

A)

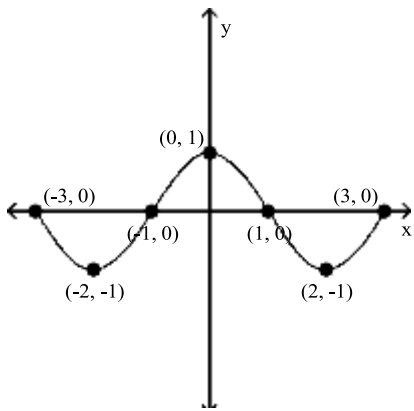

B)

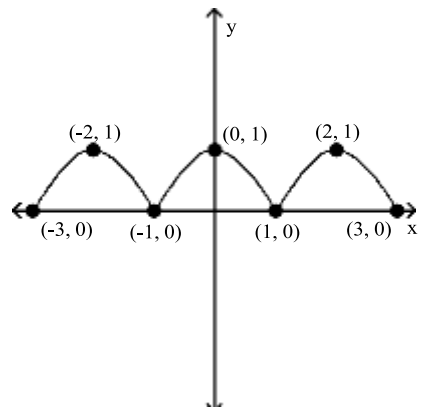

C)

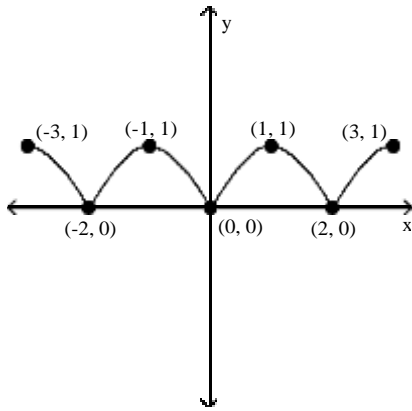

D)

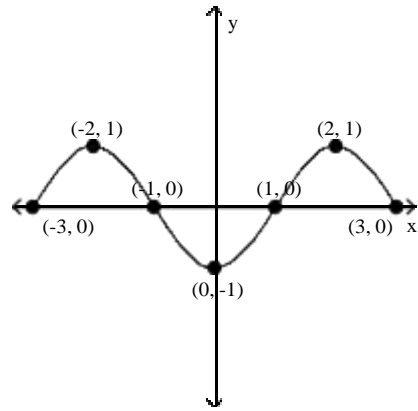

Answer: B

227)

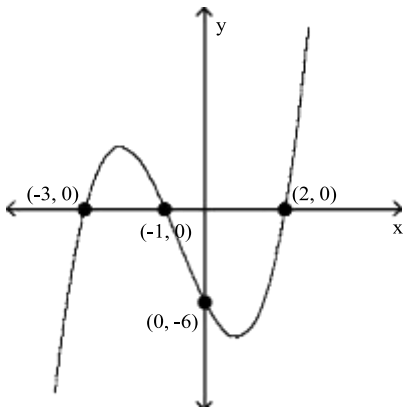

A)

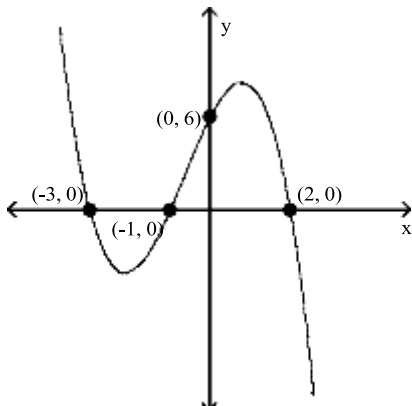

B)

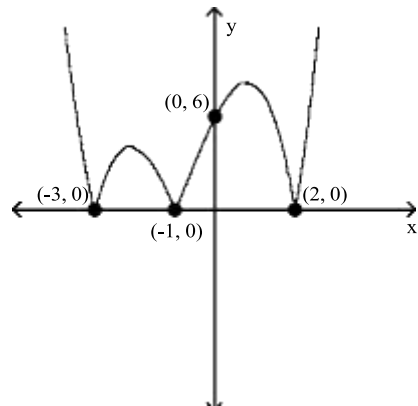

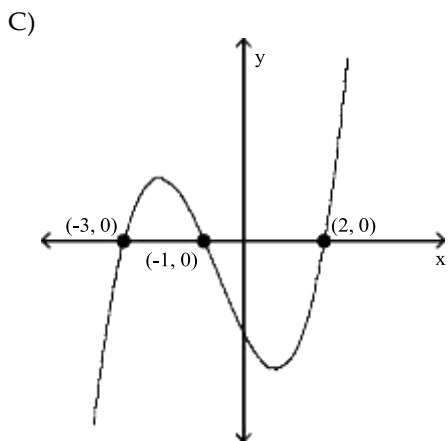

Answer: B

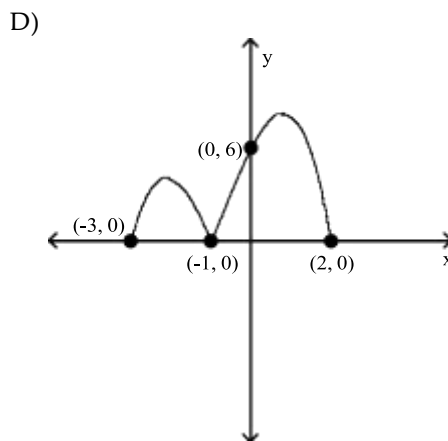

Provide an appropriate response.

228) If the range of $y = f(x)$ is $(-\infty, \infty)$, what is the range of $y = |f(x)|$?

- A) $[0, \infty)$ B) $(0, \infty)$ C) $(-\infty, \infty)$ D) $(-\infty, 0]$

Answer: A

229) If the range of $y = f(x)$ is $(-\infty, 0]$, what is the range of $y = |f(x)|$?

- A) $[0, \infty)$ B) $(-\infty, 0]$ C) $(0, \infty)$ D) $(-\infty, \infty)$

Answer: A

230) If the range of $y = f(x)$ is $[7.1, \infty)$, what is the range of $y = |f(x)|$?

- A) $[7.1, \infty)$ B) $(-\infty, \infty)$ C) $[0, \infty)$ D) $(-\infty, 7.1]$

Answer: A

231) If the range of $y = f(x)$ is $[-3.3, \infty)$, what is the range of $y = |f(x)|$?

- A) $[0, \infty)$ B) $[3.3, \infty)$ C) $(-\infty, 0]$ D) $(-\infty, -3.3]$

Answer: A

232) If the range of $y = f(x)$ is $(-\infty, 14.3)$, what is the range of $y = |f(x)|$?

- A) $(-\infty, \infty)$ B) $[0, \infty)$ C) $(-\infty, -14.3]$ D) $[14.3, \infty)$

Answer: B

233) If the range of $y = f(x)$ is $(-\infty, -6.9]$, what is the range of $y = |f(x)|$?

- A) $[-6.9, \infty)$ B) $[6.9, \infty)$ C) $[0, \infty)$ D) $(-\infty, 6.9]$

Answer: B

Use the graph, along with the indicated points, to give the solution set of the equation or inequality.

234) $y_1 > y_2$

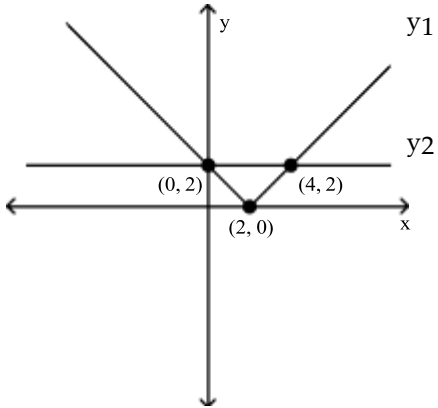

A) $(0, 4)$

B) $(-\infty, 0] \cup [4, \infty)$

C) $[0, 4]$

D) $(-\infty, 0) \cup (4, \infty)$

Answer: D

235) $y_1 = y_2$

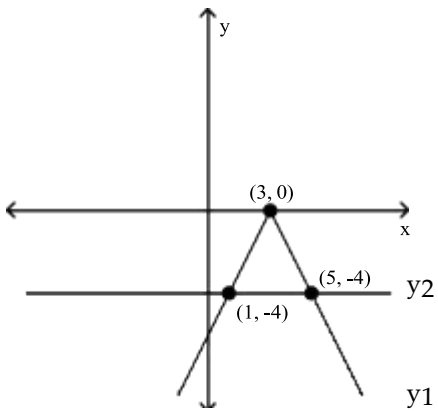

A) $\{-4\}$

B) $\{1, 5\}$

C) $[1, 5]$

D) $\{1, 5\}$

Answer: D

236) $y_1 > y_2$

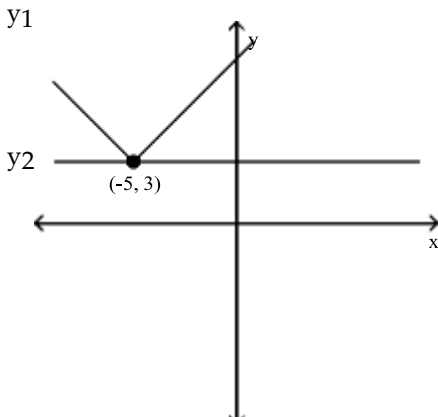

A) $(-5, \infty)$

B) \emptyset

C) $(-\infty, -5) \cup (-5, \infty)$

D) $[-5, \infty)$

Answer: C

237) $y_1 \geq y_2$

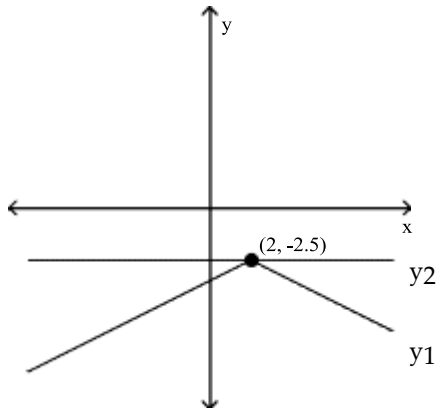

A) $\{2\}$

B) $[2, \infty)$

C) $(-\infty, \infty)$

D) $(2, \infty)$

Answer: A

238) $y_1 \leq y_2$

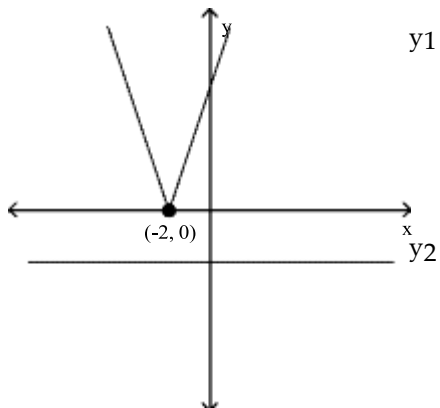

A) $(-\infty, -2]$

B) $(-\infty, -2)$

C) \emptyset

D) $(-\infty, \infty)$

Answer: C

239) $y_1 = y_2$

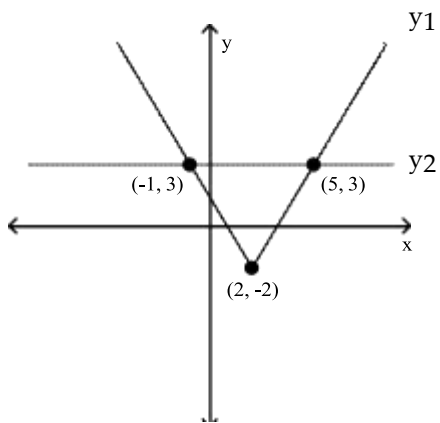

A) $\{-1, 5\}$

B) $(-1, 5)$

C) $\{1, 5\}$

D) $\{3\}$

Answer: A

Solve the equation.

240) $|x - 8| = 0$

A) $(-8, \infty)$

B) $\{-8, 8\}$

C) $(-\infty, 8)$

D) $\{8\}$

Answer: D

241) $|9x + 2| = 7$

A) $\left\{\frac{5}{9}\right\}$

B) $\left\{\frac{5}{9}, -1\right\}$

C) $\left\{1, -\frac{5}{9}\right\}$

D) $\left\{-1, -\frac{5}{9}\right\}$

Answer: B

242) $|6x - 5| = 8$

A) $\left\{\frac{13}{6}, -\frac{13}{6}\right\}$

B) $\left\{-\frac{13}{6}\right\}$

C) $\left\{-\frac{13}{6}, \frac{1}{2}\right\}$

D) $\left\{-\frac{1}{2}, \frac{13}{6}\right\}$

Answer: C

243) $|x - 6.1| = 9$

A) $\{-15.1\}$

B) $\{15.1, -2.9\}$

C) $\{15.1, 2.9\}$

D) \emptyset

Answer: B

244) $x - 8 - 5 = 2$

A) $\{15\}$

B) $\{15, 1\}$

C) $\{-15, -1\}$

D) \emptyset

Answer: B

245) $|8x + 4| + 6 = 11$

A) $\left\{\frac{1}{4}, -\frac{9}{4}\right\}$

B) $\left\{-\frac{1}{8}, \frac{9}{8}\right\}$

C) $\left\{\frac{1}{8}, -\frac{9}{8}\right\}$

D) \emptyset

Answer: C

246) $2x + 4| + 4 = 8$

A) $\{0, -2\}$

B) $\{0, -4\}$

C) $\{0, 4\}$

D) \emptyset

Answer: B

247) $7x + 3| + 1 = -5$

A) $\left\{-\frac{3}{7}, -\frac{9}{7}\right\}$

B) $\left\{\frac{3}{7}, \frac{9}{7}\right\}$

C) $\left\{-\frac{9}{7}\right\}$

D) \emptyset

Answer: D

248) $5|x + 10| - 2 = 3$

A) $\left\{9, \frac{49}{5}\right\}$

B) $\{-9\}$

C) $\{-9, -11\}$

D) $\{-11\}$

Solve the equation. Answer: C

$$249) 2(x - 1) + 3 + 5 = 6$$

A) $\left\{ \frac{3}{2}, -\frac{1}{2} \right\}$

B) $\left\{ -\frac{3}{2} \right\}$

C) $\{-1, 0\}$

D) \emptyset

Answer: C

Solve the inequality.

250) $|x + 3| > 9$

A) $(-12, 6)$

B) $(-\infty, -12) \cup (6, \infty)$

C) $(6, \infty)$

D) \emptyset

Answer: B

251) $|1 + 7x| > 4$

A) $\left(-\infty, -\frac{5}{7}\right) \cup \left(\frac{3}{7}, \infty\right)$

B) $\left(\frac{3}{7}, \frac{5}{7}\right)$

C) $\left(-\frac{5}{7}, \frac{3}{7}\right)$

D) $\left(-\infty, -\frac{1}{7}\right) \cup (1, \infty)$

Answer: A

252) $|7 - 6x| \geq 2$

A) $\left(\frac{3}{2}, \frac{5}{6}\right)$

B) $\left(-\infty, \frac{7}{6}\right) \cup \left(\frac{1}{2}, \infty\right)$

C) $\left(\frac{5}{6}, -\frac{3}{2}\right)$

D) $\left(-\infty, -\frac{3}{2}\right) \cup \left(-\frac{5}{6}, \infty\right)$

Answer: D

253) $|2 - 3x| \leq 11$

A) $\left[-\frac{13}{3}, 3\right]$

B) $\left[-3, \frac{13}{3}\right]$

C) $(-\infty, -3] \cup \left[\frac{13}{3}, \infty\right)$

D) $(-\infty, 3] \cup \left[\frac{13}{3}, \infty\right)$

Answer: B

254) $|8 - x| \leq 1$

A) $[7, 9]$

B) $[9, \infty)$

C) $(-\infty, 7] \cup [9, \infty)$

D) $[7, \infty)$

Answer: A

255) $|4x + 5 - 4| < 3$

A) $(-\infty, -3) \cup \left(\frac{1}{2}, \infty\right)$

B) $(-\infty, -3)$

C) $\left(-3, \frac{1}{2}\right)$

D) \emptyset

Answer: C

256) $|x - 5 - 9| > 9$

A) $(-\infty, -13) \cup (5, \infty)$

B) $(-\infty, -5) \cup (13, \infty)$

C) $(-13, 23)$

D) $(-\infty, -13) \cup (23, \infty)$

Answer: D

257) $|-3x - 1| > -3$

A) $\left(-\infty, \frac{2}{3}\right)$

B) $(-\infty, \infty)$

C) $\left(-\frac{4}{3}, \frac{2}{3}\right)$

D) \emptyset

Answer: B

258) $|x - 8| \leq 0$

A) $(-\infty, 8)$

B) $\{-8\}$

C) $\{8\}$

D) \emptyset

Answer: C

259) $|x - 9| < 0$
Solve the inequality.

Answer: D

B) $(-\infty, 9)$

C) $\{-9\}$

D) \emptyset

Solve the equation.

260) $9x + 2 = 6x + 9$

A) $\left\{ \frac{7}{15}, -\frac{11}{3} \right\}$

Answer: C

B) $\left\{ -\frac{11}{3}, 1 \right\}$

C) $\left\{ \frac{7}{3}, -\frac{11}{15} \right\}$

D) $\left\{ \frac{11}{3}, 1 \right\}$

261) $9x - 2 = 2x - 7$

A) $\left\{ \frac{5}{11}, \frac{9}{7} \right\}$

Answer: C

B) $\left\{ -\frac{9}{7}, 1 \right\}$

C) $\left\{ -\frac{5}{7}, \frac{9}{11} \right\}$

D) $\left\{ \frac{9}{7}, 1 \right\}$

262) $5x + 8 = 9 - 4x$

A) $\left\{ \frac{1}{9}, -17 \right\}$

Answer: A

B) $\left\{ 1, -\frac{17}{9} \right\}$

C) $\left\{ -\frac{17}{9}, 1 \right\}$

D) $\left\{ \frac{17}{9}, 1 \right\}$

263) $-10 + 7x = 7 - 2x$

A) $\left\{ \frac{1}{3}, 1 \right\}$

Answer: B

B) $\left\{ \frac{17}{9}, \frac{3}{5} \right\}$

C) $\left\{ -\frac{1}{3}, 1 \right\}$

D) $\left\{ \frac{17}{5}, \frac{1}{3} \right\}$

264) $5x - 7 = x + 6$

A) $\frac{13}{4}$

Answer: B

B) $\left\{ \frac{13}{4}, \frac{1}{6} \right\}$

C) $\left\{ -\frac{13}{4}, -\frac{1}{6} \right\}$

D) \emptyset

265) $3x + 3 = x - 7$

A) $\{-5\}$

Answer: B

B) $\{-5, 1\}$

C) $\{5, -1\}$

D) \emptyset

266) $4x + 3 = x - 4$

A) $\left\{ \frac{7}{3}, -\frac{1}{3} \right\}$

Answer: B

B) $\left\{ -\frac{7}{3}, \frac{1}{5} \right\}$

C) $\left\{ -\frac{7}{3}, \frac{10}{3} \right\}$

D) \emptyset

267) $\frac{1}{x+2} = 2$

$$3x - 2 = 4$$

Solve the equation.

A) $\{10, 10\}$

B) $\{16, 0\}$

C) $\{16, 12\}$

D) \emptyset

Answer: B

268) $3x + 6 = 3x - 5$

A) $\left\{ \emptyset, -\frac{11}{6} \right\}$

B) $\left\{ -\frac{1}{6} \right\}$

C) $\left\{ 0, -\frac{1}{6} \right\}$

D) \emptyset

Answer: B

Solve the inequality graphically.

269) $3x + 9 > x - 1$



A) $(-5, -2)$

B) $(-\infty, -5) \cup (-2, \infty)$

C) $(2, 5)$

D) \emptyset

Answer: B

270) $3x + 9 < x - 1$



A) $(2, 5)$

B) $(-5, -2)$

C) $(-\infty, -5) \cup (-2, \infty)$

D) \emptyset

Answer: B

271) $\left| \frac{1}{2}x + 2 \right| > \left| \frac{3}{4}x - 2 \right|$

A) $(16, \infty)$

B) $(-\infty, 16)$

C) $(0, 16)$

D) $(-\infty, 0) \cup (16, \infty)$

Answer: C

272) $\left| \frac{1}{2}x + 2 \right| < \left| \frac{3}{4}x - 2 \right|$

A) $(16, \infty)$

B) $(-\infty, 0) \cup (16, \infty)$

C) $(-\infty, 16)$

D) $(0, 16)$

Answer: B

Solve the equation or inequality graphically. Express solutions or endpoints of intervals rounded to the nearest hundredth, if necessary.

273) $|3x - 11| = \sqrt{x + 5}$

A) $\{-4.71, -2.74\}$

B) $\{4.71, 4.71\}$

C) $\{4.71, 2.74\}$

D) $\{-4.71, 2.74\}$

Answer: C

274) $3x - 5 = 6x - 2$



A) $\{-0.78\}$

B) \emptyset

C) $\{0.78\}$

D) $\{1\}$

Answer: C

275) $-|7x - 9| \geq -x - 6$

A) $[-0.38, -2.5]$

B) $[0.38, 2.5]$

C) $(-\infty, 0.38] \cup [2.5, \infty)$

D) $(-\infty, -2.5] \cup [-0.38, \infty)$

Answer: B

276) $x + 3 < .2x - 5$



A) $(-\infty, -3] \cup [2.5, \infty)$

B) $(-\infty, \infty)$

C) \emptyset

D) $[-3, 2.5]$

Answer: C

277) $3x + 5 > -4x - 4$



A) $[1.67, 0.8]$

B) \emptyset

C) $(-\infty, \infty)$

D) $(-\infty, 1.67] \cup [0.8, \infty)$

Answer: C

278) $x + 7 + 5 \geq -x - 11$

$$|\sqrt{x}| \sqrt{x} \sqrt{x}$$

(Provide exact answer.)

Solve the inequality graphically.

A) $(-\infty, -\sqrt{11}] \cup [\sqrt{11}, \infty)$

C) $(-\infty, \infty)$

Answer: C

B) \emptyset

D) $(-\infty, -\sqrt{5}] \cup [\sqrt{5}, \infty)$

279) $x + x - 8 = 16$

$| \quad | \quad | \quad |$

A) $\{-4\}$

B) $\{4, 12\}$

C) $\{-4, 12\}$

D) \emptyset

Answer: C

280) $x + 2 + x - 8 = 16$

$| \quad | \quad | \quad |$

A) $\{11\}$

B) $\{-11, 5\}$

C) $\{11, -5\}$

D) \emptyset

Answer: C

Solve the problem.

281) The formula to find Fahrenheit temperature, F , given Celsius temperature, C , is $F = \frac{9}{5}C + 32$. Find the range, in

Fahrenheit, when the temperature in Celsius is between 3°C and 6°C , inclusive. Round to the nearest tenth.

A) $33.7^\circ\text{F} \leq \text{Temperature} \leq 42.8^\circ\text{F}$

B) $37.4^\circ\text{F} \leq \text{Temperature} \leq 42.8^\circ\text{F}$

C) $21.4^\circ\text{F} \leq \text{Temperature} \leq 26.8^\circ\text{F}$

D) $5.4^\circ\text{F} \leq \text{Temperature} \leq 10.8^\circ\text{F}$

Answer: B

282) The formula to find Celsius temperature, C , given Fahrenheit temperature, F , is $C = \frac{5}{9}(F - 32)$. If the processing

temperature of a chemical ranges from 302°F to 347°F , inclusive, then what is the range of its temperature in degrees Celsius?

A) $270^\circ\text{C} \leq \text{Temperature} \leq 315^\circ\text{C}$

B) $32^\circ\text{C} \leq \text{Temperature} \leq 45^\circ\text{C}$

C) $100^\circ\text{C} \leq \text{Temperature} \leq 175^\circ\text{C}$

D) $150^\circ\text{C} \leq \text{Temperature} \leq 175^\circ\text{C}$

Answer: D

283) The temperature on the surface of the planet Krypton in degrees Celsius satisfies the inequality $|C + 75| \leq 52$. What range of temperatures corresponds to this inequality? (Use interval notation.)

A) $[-127, 23]$

B) $[-127, -23]$

C) $[23, 127]$

D) $[-23, 127]$

Answer: B

284) Dr. Hughes found that the weight, w , of 98% of his students at Cantanople University satisfied the inequality $|w - 152| < 57$. What range of weights corresponds to this inequality? (Use interval notation.)

A) $(95, 209)$

B) $(-\infty, 95) \cup (209, \infty)$

C) $(-\infty, 95] \cup [209, \infty)$

D) $[95, 209]$

Answer: A

285) The Fahrenheit temperature, F , in Siber City in October ranges from 71°F to 39°F . Write an absolute value inequality whose solution is this range.

A) $|F| > 39$

B) $|F| < 71$

C) $|F - 55| < 16$

D) $|F - 16| < 55$

Answer: C

286) In a milling operation, the thickness of the metal bars that can be produced satisfies the inequality $|x - 1.88| \leq 1.27$. What range of thicknesses corresponds to this inequality?

A) $[0.61, 6.3]$

B) $[0.31, 3.15]$

C) $[1.27, 1.88]$

D) $[0.61, 3.15]$

Answer: D

287) The average annual growth rate of Cyprus trees in inches satisfies the inequality $|x - 4.72| \leq 3.27$. What range of growth corresponds to this inequality?

A) $[1.45, 7.99]$

B) $[3.27, 4.72]$

C) $[0.73, 7.99]$

D) $[1.45, 15.98]$

Answer: A

288) The number of non-text books read by college students ranges from 10 to 62. Using B as the variable, write an absolute value inequality that corresponds to this range.

A) $|B - 26| \leq 36$

B) $|B - 52| \leq 10$

C) $|B - 36| \leq 26$

D) $|B - 10| \leq 52$

Answer: C

289) A real estate development consists of home sites that range in width from 60 to 94 feet and in depth from 121 to 183 feet. Using x as the variable in both cases, write absolute value inequalities that correspond to these ranges.

A) $|x - 60| \leq 34, |x - 121| \leq 62$

B) $|x - 17| \leq 77, |x - 31| \leq 152$

C) $|x - 34| \leq 60, |x - 62| \leq 121$

D) $|x - 77| \leq 17, |x - 152| \leq 31$

Answer: D

290) The inequality $|T - 35| \leq 14$ describes the range of monthly average temperatures T in degrees Fahrenheit at a

City X. (i) Solve the inequality. (ii) If the high and low monthly average temperatures satisfy equality, interpret the inequality.

A) $T \leq 49$; The monthly averages are always less than or equal to 49°F .

B) $12 \leq T \leq 58$; The monthly averages are always within 23° of 35°F .

C) $12 \leq T$; The monthly averages are always greater than or equal to 12°F .

D) $21 \leq T \leq 49$; The monthly averages are always within 14° of 35°F .

Answer: D

Provide an appropriate response.

291) True or false? The graph of $y = |f(x)|$ is the same as that of $y = f(x)$ for values of $f(x)$ that are nonnegative; and for values of $y = f(x)$ that are negative, the graph is reflected across the x-axis.

A) False

B) True

Answer: B

292) One of the graphs below is that of $y = f(x)$, and the other is that of $y = |f(x)|$. State which is the graph of $y = |f(x)|$.

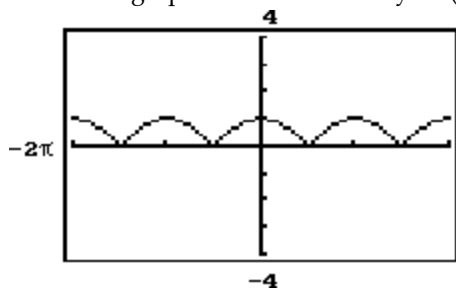

i

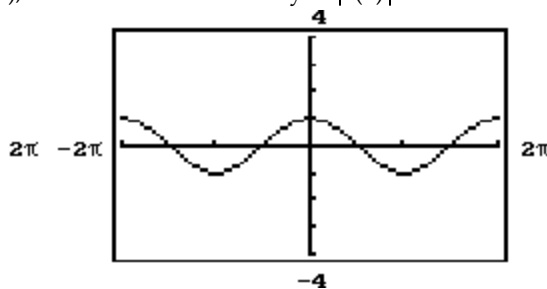

ii

A) ii

B) i

Answer: B

293) One of the graphs below is that of $y = f(x)$ and the other is that of $y = |f(x)|$. State which is the graph of $y = |f(x)|$.

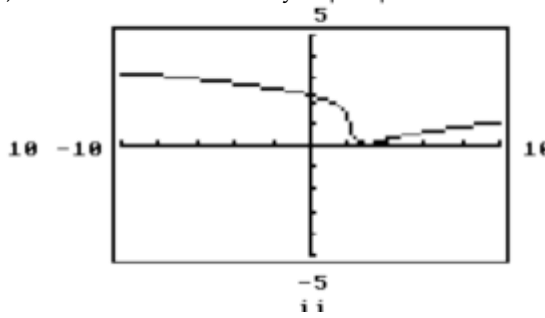
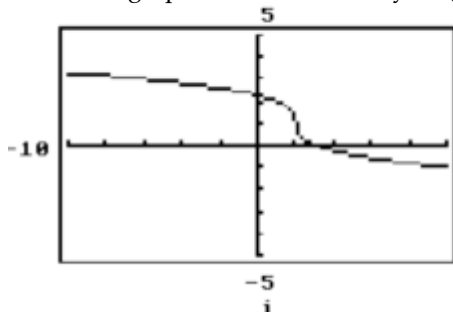

A) ii

B) i

Answer: A

294) Given $a = 15$, $b = -23$, which of the following statements is false?

A) $|a/b| = a/b$

B) $|ab| = -ab$

C) $|a| + |b| \geq -(a+b)$

Answer: A

295) Given $a = -1$, $b = -13$, which of the following statements is false?

A) $|a/b| = a/b$

B) $|a| + |b| = -(a+b)$

C) $|ab| = -ab$

Answer: C

296) The graph shown is a translation of the function $y = |x|$ of the form $y = |x - h| + k$. What are the values of h and k ?

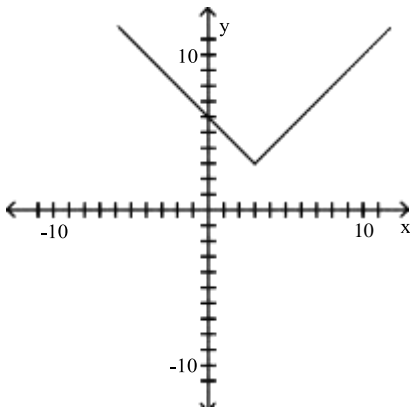

A) $h = 3, k = 3$

B) $h = -3, k = -3$

C) $h = -3, k = 3$

D) $h = 3, k = -3$

Answer: A

297) Use graphing to determine the domain and range of $y = |f(x)|$ for $f(x) = -(x - 5)^2 - 3$.

A) D: $[0, \infty)$; R: $(-\infty, 3]$

B) D: $[0, \infty)$; R: $(-\infty, -3]$

C) D: $(-\infty, \infty)$; R: $[-3, \infty)$

D) D: $(-\infty, \infty)$; R: $[3, \infty)$

Answer: D

298) Use graphing to determine the domain and range of $y = |f(x)|$ for $f(x) = |x - 3| - 6$.

A) D: $(-\infty, \infty)$; R: $[0, \infty)$

B) D: $(-\infty, \infty)$; R: $[6, \infty)$

C) D: $[0, \infty)$; R: $(-\infty, \infty)$

D) D: $[0, \infty)$; R: $[-6, \infty)$

Answer: A

Find the requested value.

299)

$$f(-7) \text{ for } f(x) = \begin{cases} 2x & \text{if } x \leq -1 \\ x - 8 & \text{if } x > -1 \end{cases}$$

A) -14

B) 14

C) -15

D) -1

Answer: A

300)

$$f(0) \text{ for } f(x) = \begin{cases} x - 2 & \text{if } x < 5 \\ 9 - x & \text{if } x \geq 5 \end{cases}$$

A) 3

B) 9

C) 4

D) -2

Answer: D

301)

$$f(6) \text{ for } f(x) = \begin{cases} 4x + 6 & \text{if } x \leq 0 \\ 2 - 5x & \text{if } 0 < x < 5 \\ x & \text{if } x \geq 5 \end{cases}$$

A) 5

B) 6

C) 30

D) -28

Answer: B

302)

$$f(6) \text{ for } f(x) = \begin{cases} 5x + 1 & \text{if } x < 6 \\ 6x & \text{if } 6 \leq x \leq 9 \\ 6 - 9x & \text{if } x > 9 \end{cases}$$

A) 36

B) -48

C) 6

D) 82

Answer: A

303)

$$f(-7) \text{ for } f(x) = \begin{cases} 5x + 1 & \text{if } x < 7 \\ 7x & \text{if } 7 \leq x \leq 11 \\ 7 - 5x & \text{if } x > 11 \end{cases}$$

A) 42

B) -49

C) 36

D) -34

Answer: D

Graph the function.

304)

$$f(x) = \begin{cases} -4 & \text{if } x \geq 1 \\ -1 - x & \text{if } x < 1 \end{cases}$$

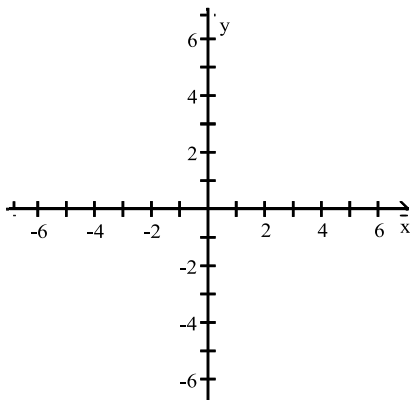

A)

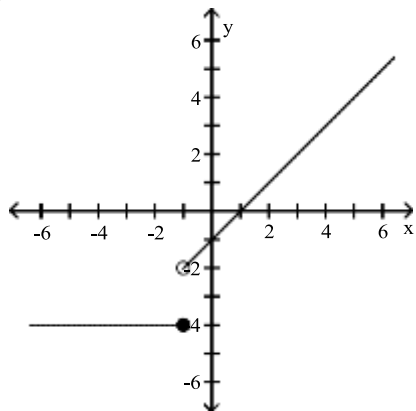

B)

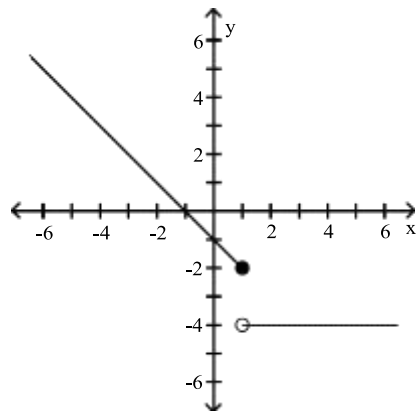

C)

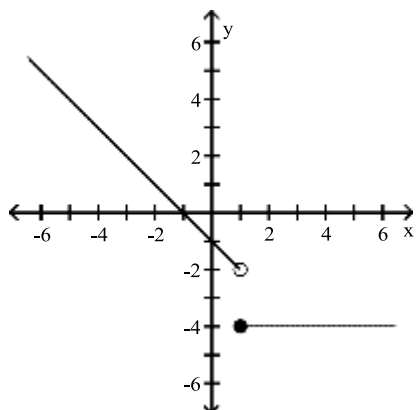

D)

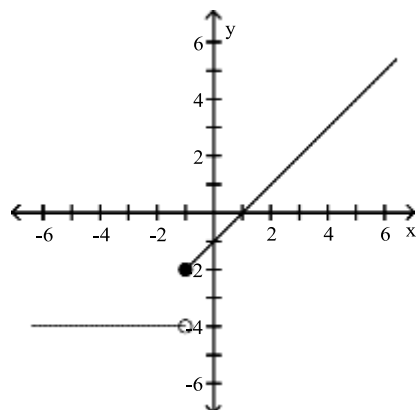

Answer: C

305)

$$f(x) = \begin{cases} x - 1 & \text{if } x > 0 \\ 4 & \text{if } x \leq 0 \end{cases}$$

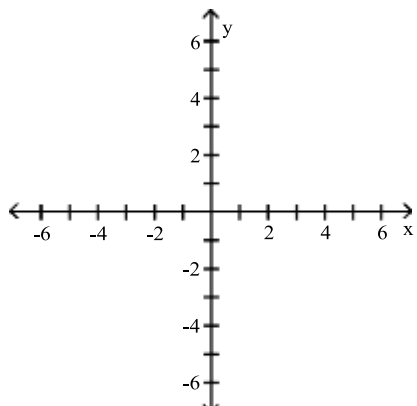

A)

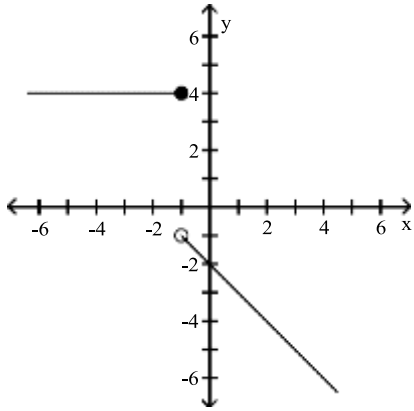

B)

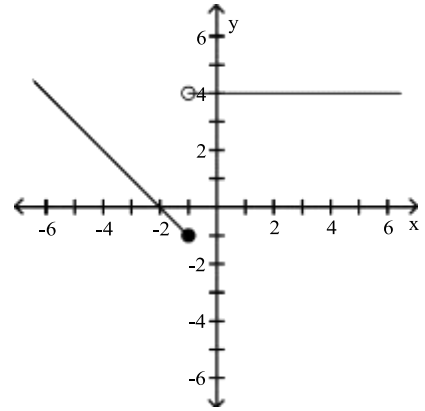

C)

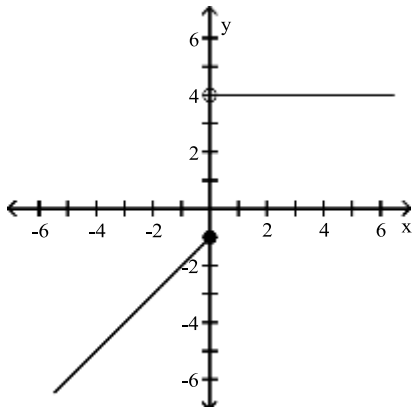

D)

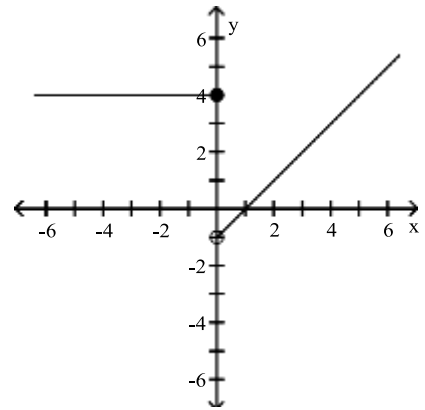

Answer: D

306)

$$f(x) = \begin{cases} 9x + 6 & \text{if } x < 0 \\ 2x^2 - 2 & \text{if } x \geq 0 \end{cases}$$

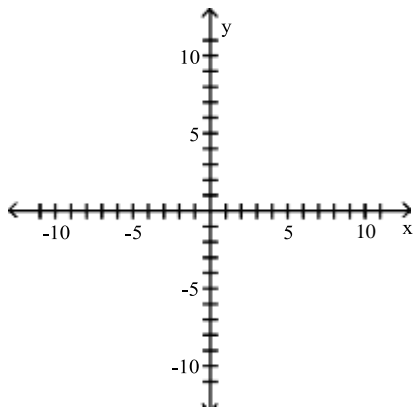

A)

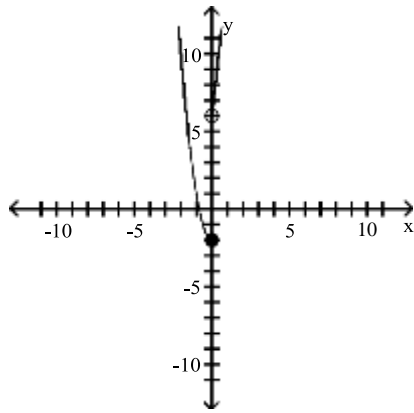

B)

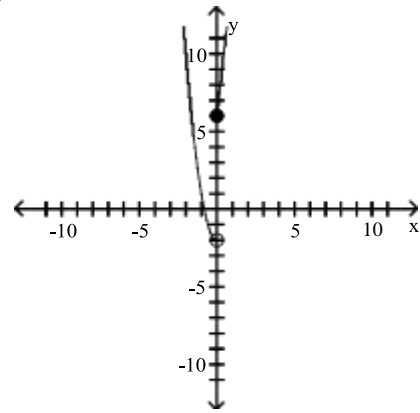

C)

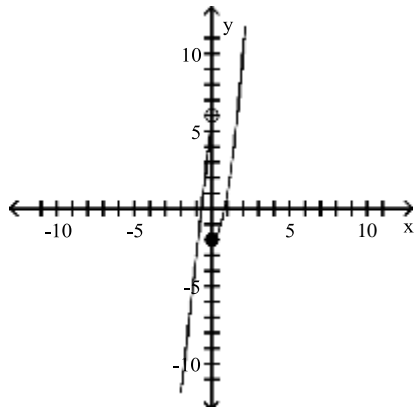

D)

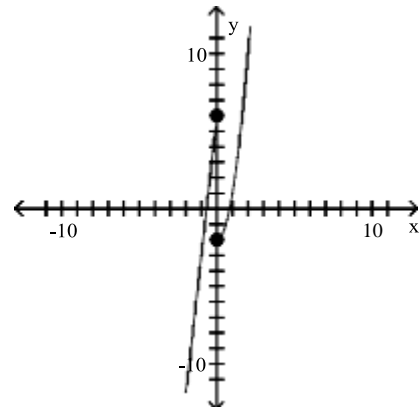

Answer: C

307)

$$f(x) = \begin{cases} x^2 - 4 & \text{if } x < -1 \\ 0 & \text{if } -1 \leq x \leq 1 \\ x^2 + 4 & \text{if } 1 < x \end{cases}$$

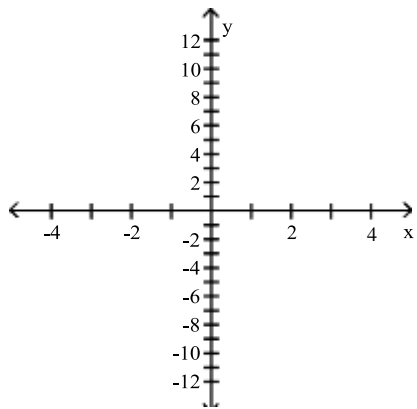

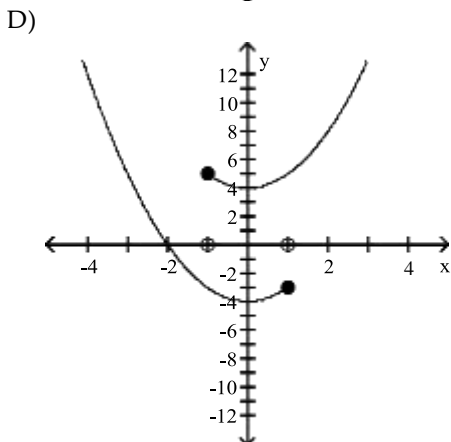
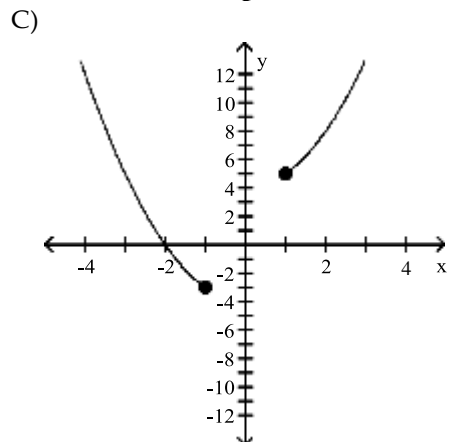
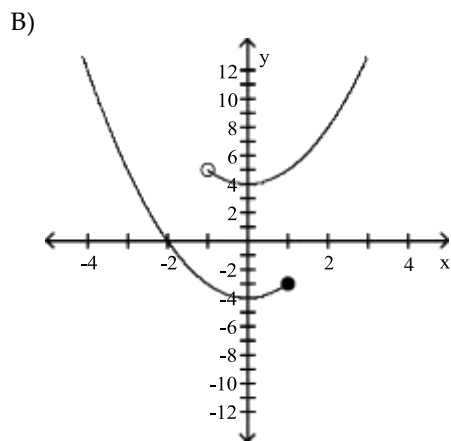
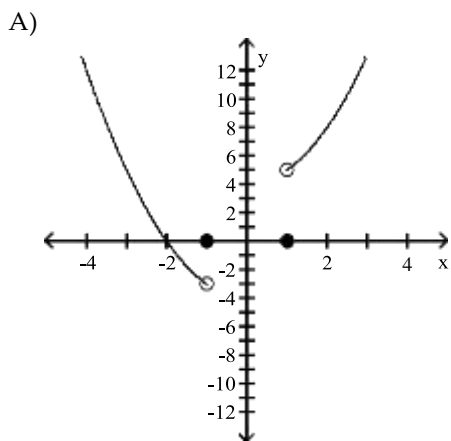

Answer: A

308)

$$f(x) = \begin{cases} |x| + 5 & \text{if } x < 0 \\ 5 & \text{if } x \geq 0 \end{cases}$$

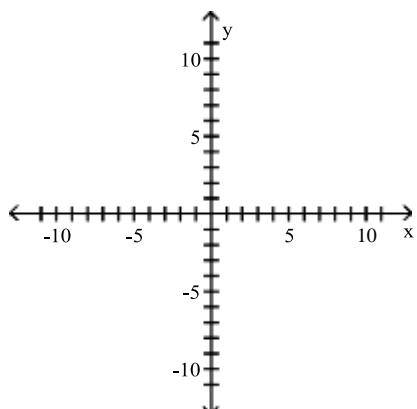

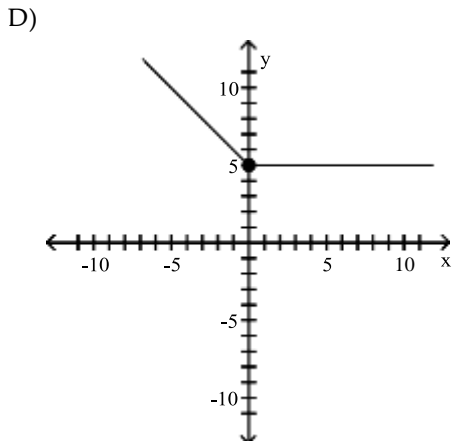
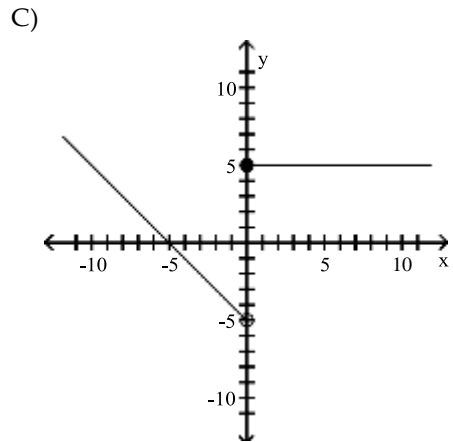
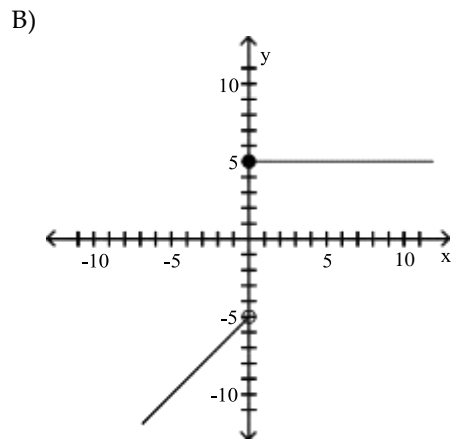
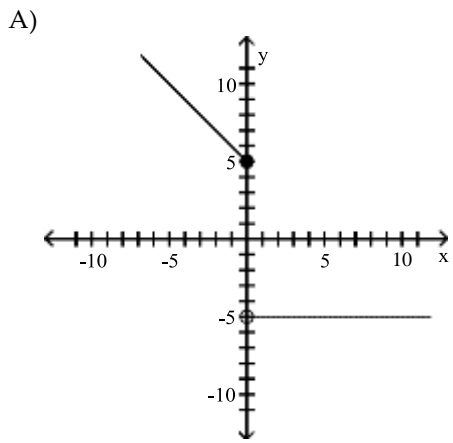

Answer: D

309)

$$f(x) = \begin{cases} 5x + 2 & \text{if } x < -2 \\ x & \text{if } -2 \leq x \leq 3 \\ 4x - 1 & \text{if } x > 3 \end{cases}$$

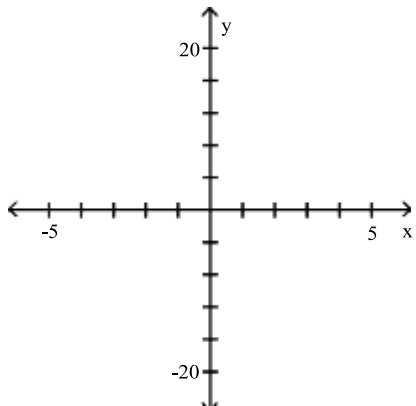

A)

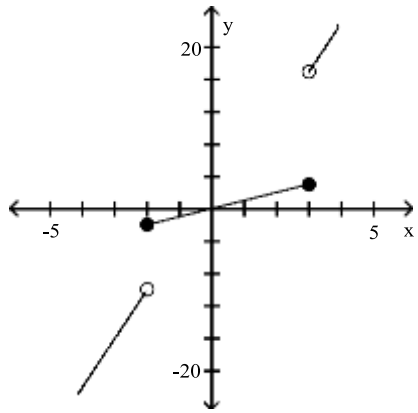

B)

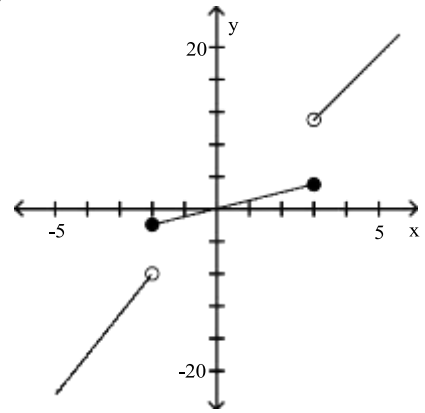

C)

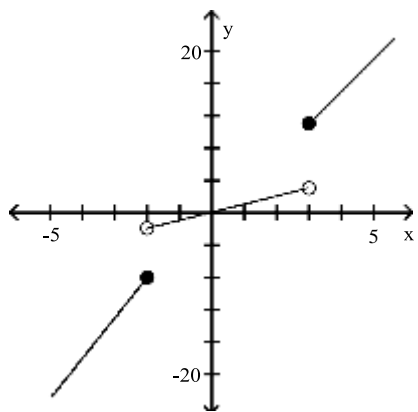

D)

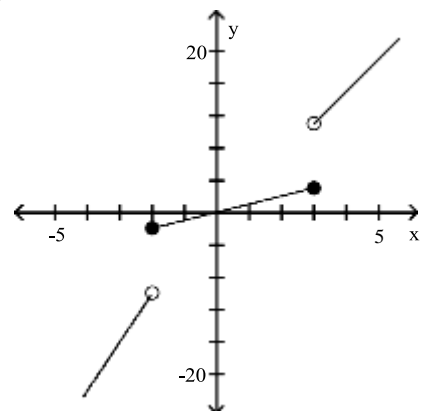

Answer: B

Use a graphing calculator to graph the piecewise-defined function, using the window indicated.

$$310) f(x) = \begin{cases} x + 2 & \text{if } x \leq 3 \\ 5 & \text{if } x > 3 \end{cases}; \text{ window } [-4, 6] \text{ by } [-2, 8]$$

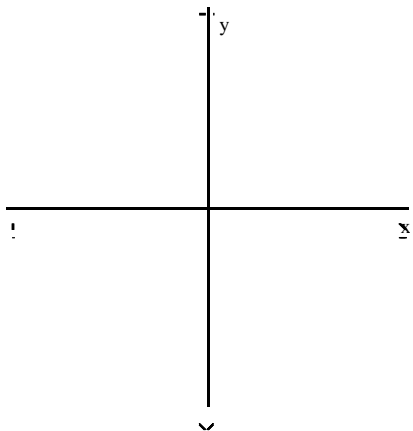

A)

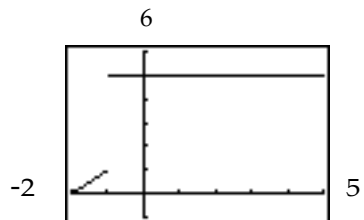

B)

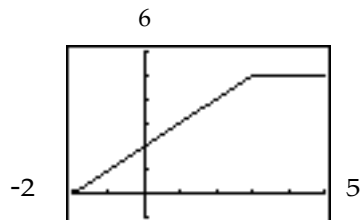

C)

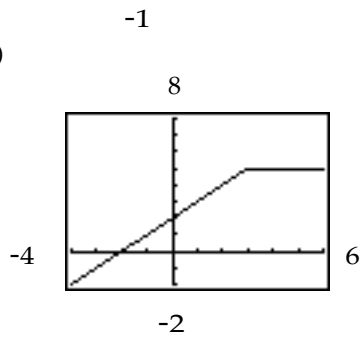

D)

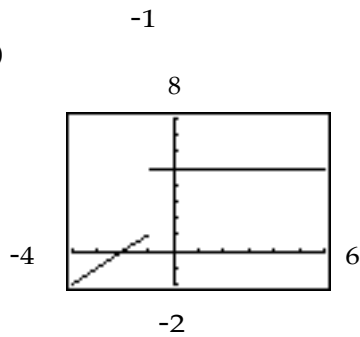

Answer: C

$$311) f(x) = \begin{cases} 4 - x & \text{if } x \leq 3 \\ 2x - 5 & \text{if } x > 3 \end{cases}; \text{ window } [-2, 5] \text{ by } [-1, 6]$$

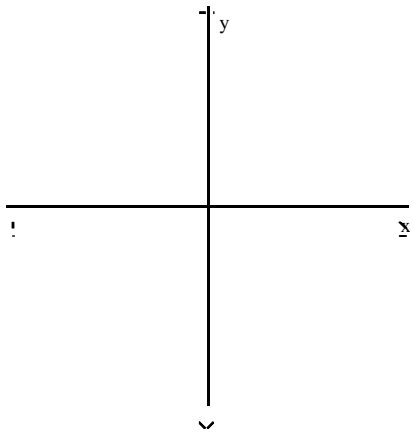

A)

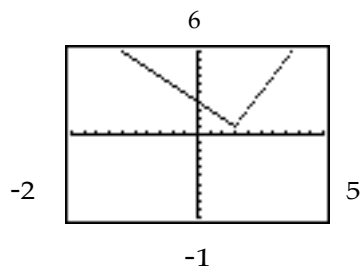

C)

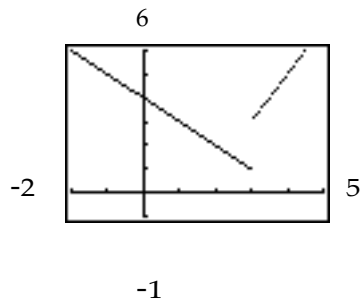

B)

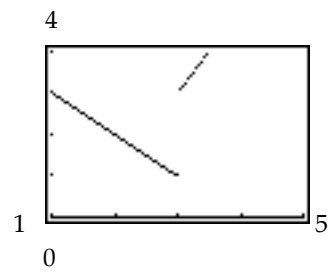

D)

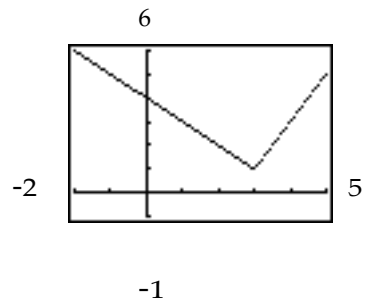

Answer: D

$$312) f(x) = \begin{cases} 2 - x & \text{if } x < -2 \\ 2x - 1 & \text{if } x \geq -2 \end{cases}; \text{ window } [-10, 6] \text{ by } [-6, 10]$$

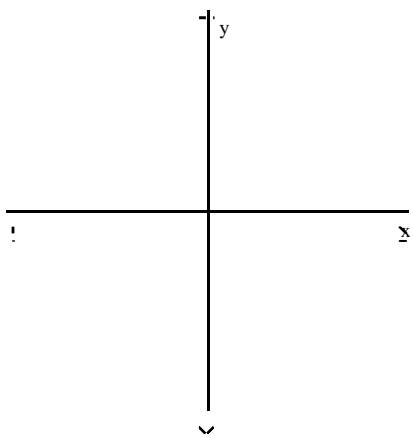

A)

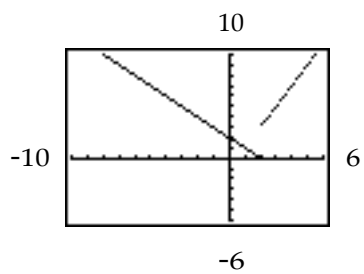

C)

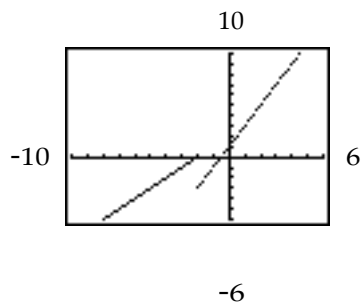

B)

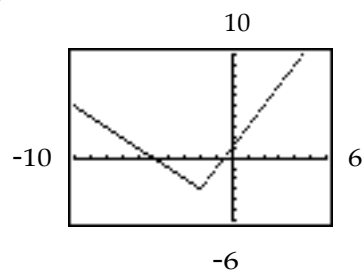

D)

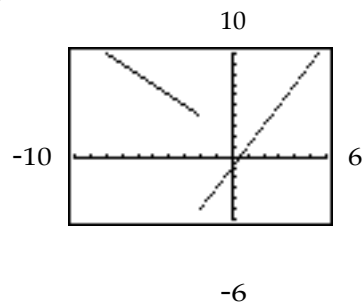

Answer: D

$$313) f(x) = \begin{cases} 3x + 1 & \text{if } x < 0 \\ 2x - 1 & \text{if } x \geq 0 \end{cases}; \text{ window } [-4, 4] \text{ by } [-4, 4]$$

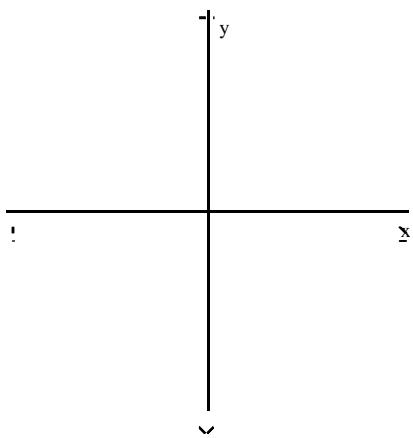

A)

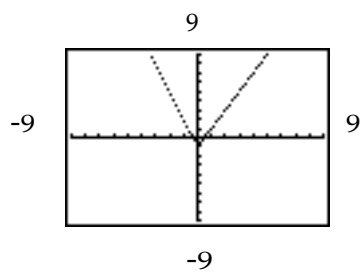

C)

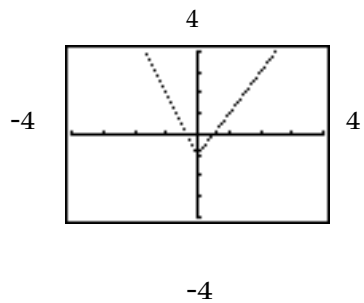

B)

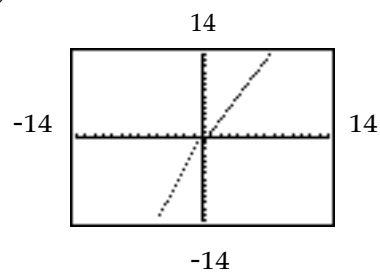

D)

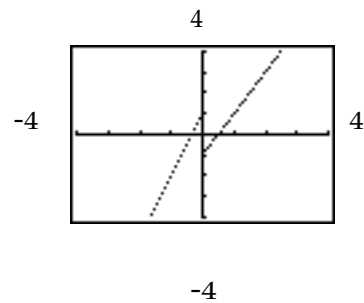

Answer: D

$$314) f(x) = \begin{cases} x - 1 & \text{if } x < -2 \\ x + 1 & \text{if } -2 \leq x < 3 \\ -2x & \text{if } x \geq 3 \end{cases} ; \text{ window } [-6, 12] \text{ by } [-12, 6]$$

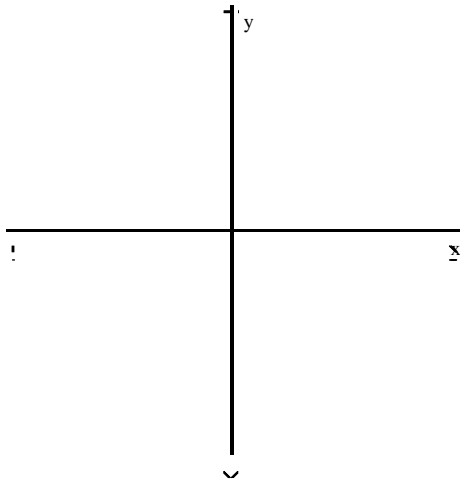

A)

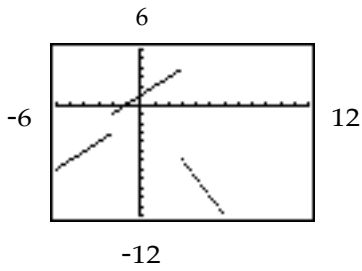

C)

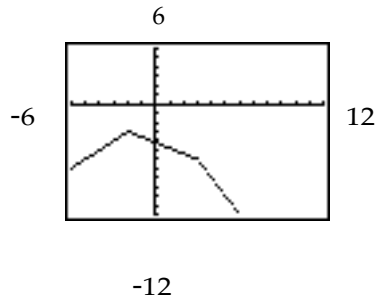

B)

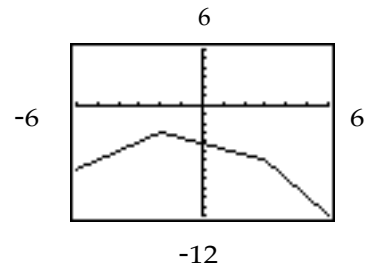

D)

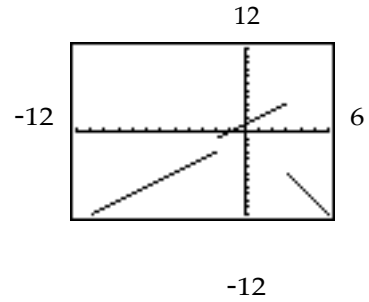

Answer: A

$$315) f(x) = \begin{cases} x - 1 & \text{if } x < -2 \\ -0.6x - 4.2 & \text{if } -2 \leq x < 3 \\ -2x & \text{if } x \geq 3 \end{cases}; \text{ window } [-6, 6] \text{ by } [-12, 6]$$

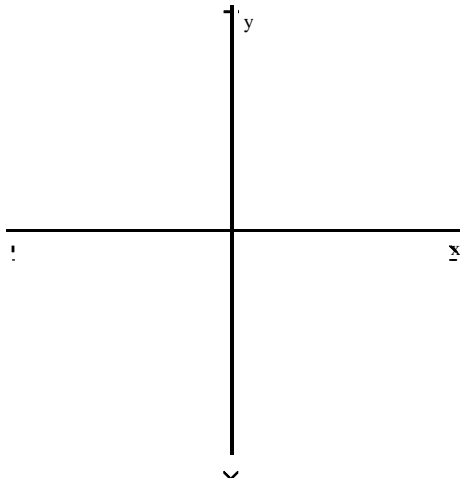

A)

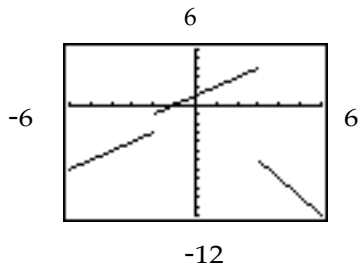

C)

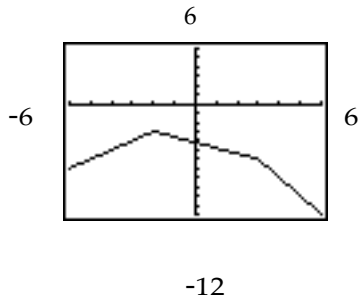

B)

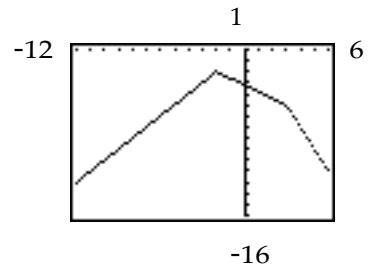

D)

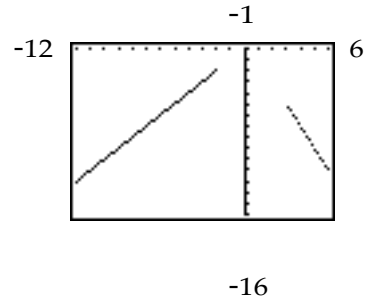

Answer: C

$$316) f(x) = \begin{cases} x + 3 & \text{if } x < -2 \\ x^2 - 3 & \text{if } x \geq -2 \end{cases}; \text{ window } [-10, 5] \text{ by } [-10, 10]$$

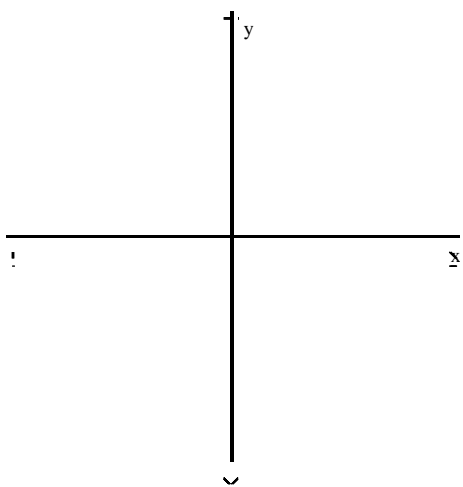

A)

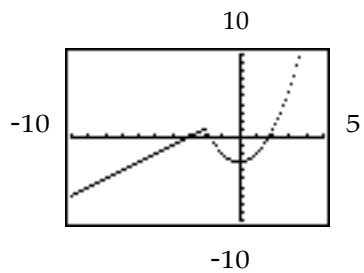

C)

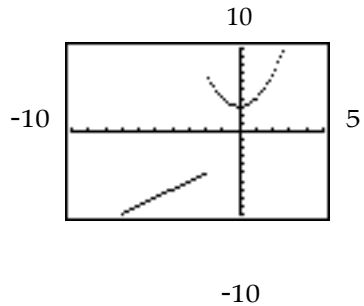

B)

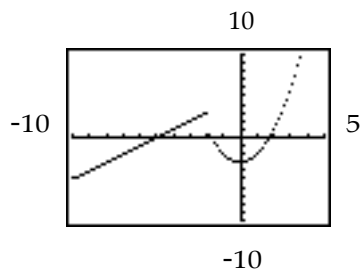

D)

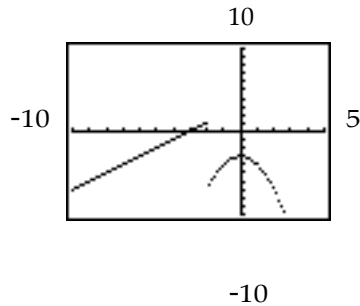

Answer: A

$$317) f(x) = \begin{cases} x^3 & \text{if } x < 0 \\ -x^2 - 3 & \text{if } x \geq 0 \end{cases}; \text{ window } [-5, 5] \text{ by } [-10, 2]$$

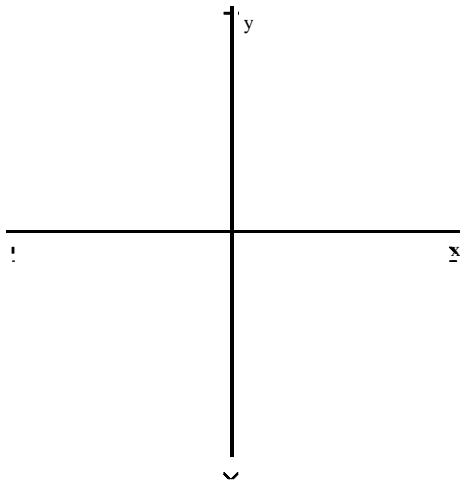

A)

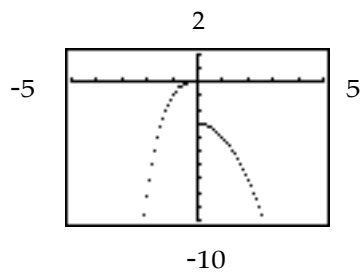

C)

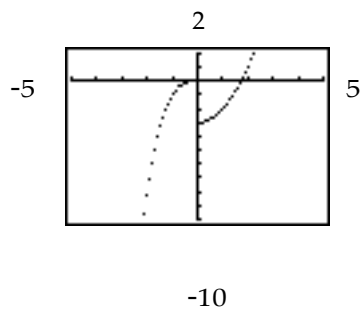

B)

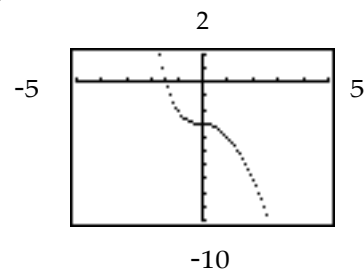

D)

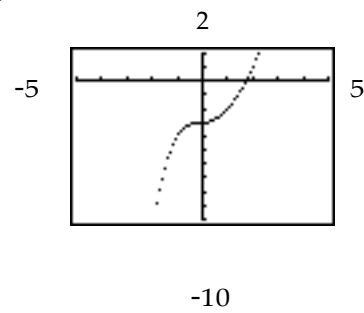

Answer: A

$$318) f(x) = \begin{cases} x^3 - 1 & \text{if } x < 2 \\ -x^2 + 1 & \text{if } x \geq 2 \end{cases}; \text{ window } [-5, 5] \text{ by } [-10, 10]$$

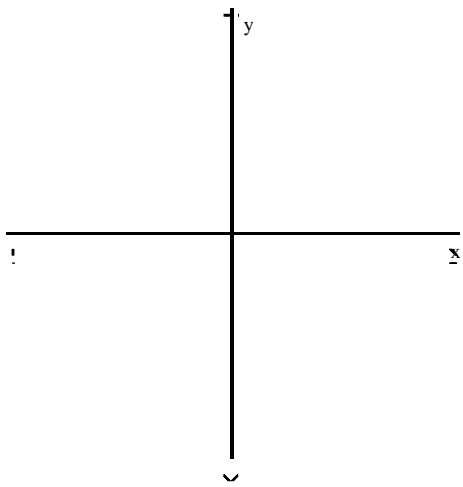

A)

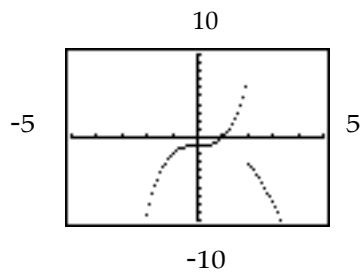

B)

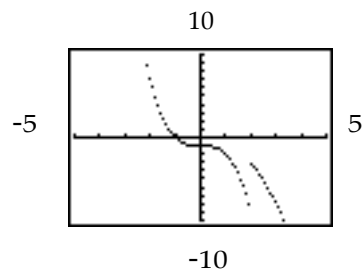

C)

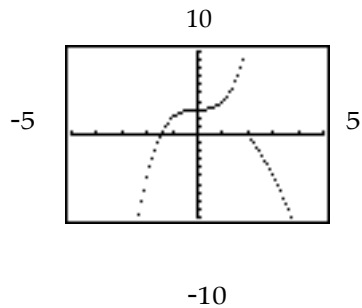

D)

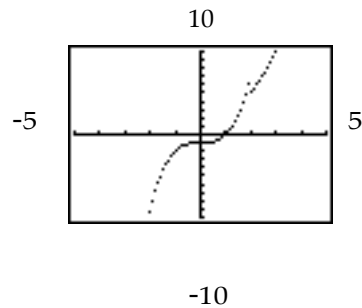

Answer: A

$$319) f(x) = \begin{cases} \sqrt[3]{x} & \text{if } x < 0 \\ -x^2 + 5 & \text{if } x \geq 0 \end{cases}; \text{ window } [-6, 5] \text{ by } [-10, 6]$$

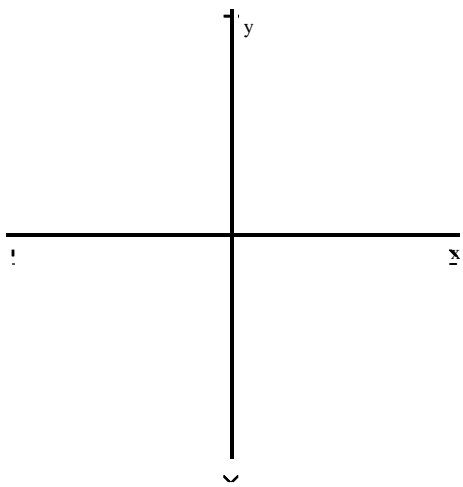

A)

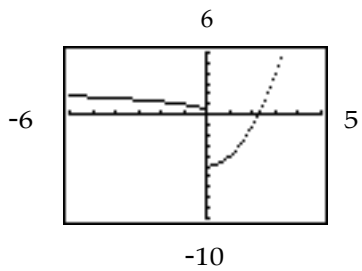

C)

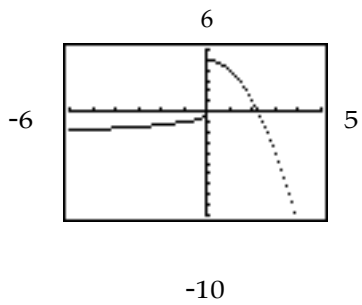

B)

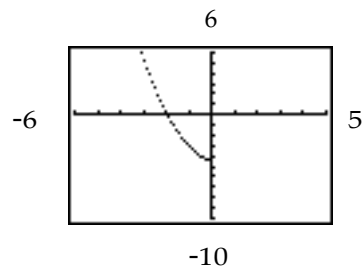

D)

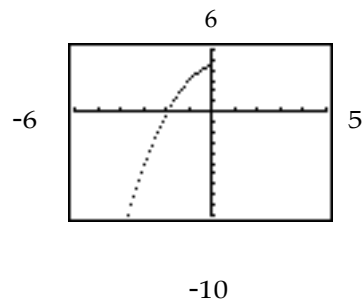

Answer: C

Give a formula for a piecewise-defined function f for the graph shown.

320)

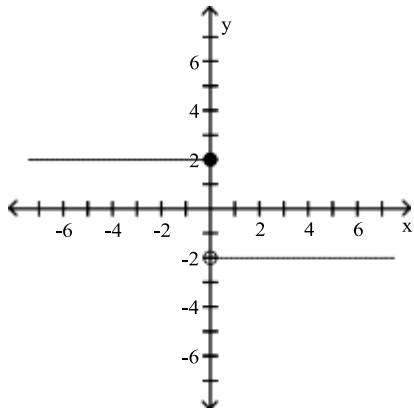

A)

$$f(x) = \begin{cases} 2 & \text{if } x \leq 0 \\ -2 & \text{if } x < 0 \end{cases}$$

C)

$$f(x) = \begin{cases} 2x & \text{if } x \leq 0 \\ -2x & \text{if } x > 0 \end{cases}$$

B)

$$f(x) = \begin{cases} 2 & \text{if } x < 0 \\ -2 & \text{if } x \geq 0 \end{cases}$$

D)

$$f(x) = \begin{cases} -2 & \text{if } x \leq 0 \\ 2 & \text{if } x > 0 \end{cases}$$

Answer: A

321)

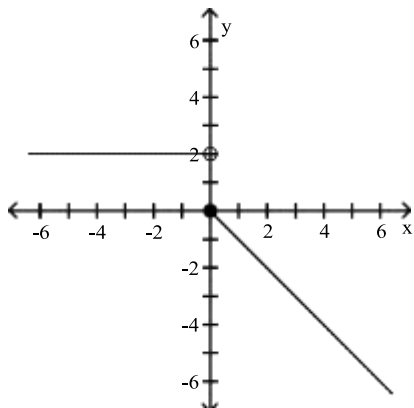

A)

$$f(x) = \begin{cases} 2 & \text{if } x \leq 0 \\ x & \text{if } x > 0 \end{cases}$$

B)

$$f(x) = \begin{cases} 2 & \text{if } x < 0 \\ -2x & \text{if } x \geq 0 \end{cases}$$

C)

$$f(x) = \begin{cases} 2 & \text{if } x < 0 \\ -x & \text{if } x \geq 0 \end{cases}$$

D)

$$f(x) = \begin{cases} 2 & \text{if } x \leq 0 \\ -x & \text{if } x > 0 \end{cases}$$

Answer: C

322)

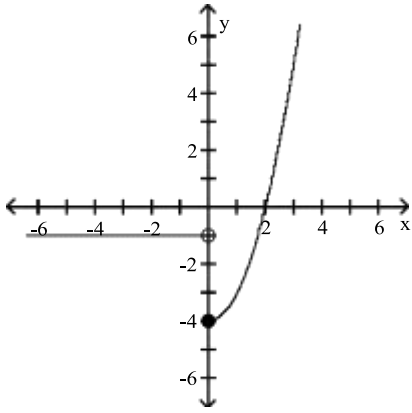

A)

$$f(x) = \begin{cases} 1 & \text{if } x < 0 \\ x^2 & \text{if } x \geq 0 \end{cases}$$

C)

$$f(x) = \begin{cases} 1 & \text{if } x \leq 0 \\ x^2 - 4 & \text{if } x > 0 \end{cases}$$

B)

$$f(x) = \begin{cases} -1 & \text{if } x < 0 \\ x^2 - 4 & \text{if } x \geq 0 \end{cases}$$

D)

$$f(x) = \begin{cases} |x| & \text{if } x < 0 \\ |x| - 4 & \text{if } x \geq 0 \end{cases}$$

Answer: B

323)

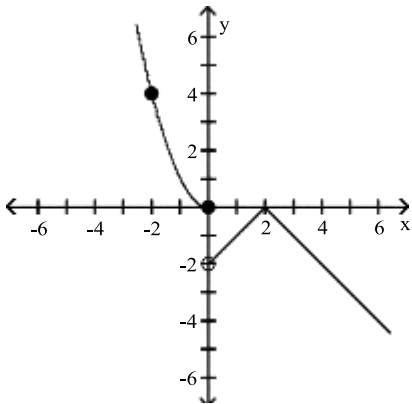

A)

$$f(x) = \begin{cases} x^2 & \text{if } x \leq 0 \\ -|x - 2| & \text{if } x > 0 \end{cases}$$

C)

$$f(x) = \begin{cases} -x^2 & \text{if } x \leq 0 \\ |x - 2| & \text{if } x > 0 \end{cases}$$

B)

$$f(x) = \begin{cases} x^2 & \text{if } x \leq 0 \\ -|x + 2| & \text{if } x > 0 \end{cases}$$

D)

$$f(x) = \begin{cases} -|x - 2| & \text{if } x < 0 \\ x^2 & \text{if } x \geq 0 \end{cases}$$

Answer: A

324)

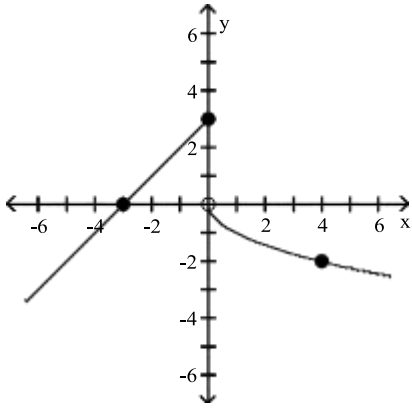

A)

$$f(x) = \begin{cases} x + 3 & \text{if } x \leq 0 \\ \sqrt{x} & \text{if } x > 0 \end{cases}$$

C)

$$f(x) = \begin{cases} -x + 3 & \text{if } x \leq 0 \\ \sqrt{x} & \text{if } x > 0 \end{cases}$$

B)

$$f(x) = \begin{cases} x - 3 & \text{if } x \leq 0 \\ -x^2 & \text{if } x > 0 \end{cases}$$

D)

$$f(x) = \begin{cases} x + 3 & \text{if } x \leq 0 \\ \sqrt{x} & \text{if } x > 0 \end{cases}$$

Answer: A

325)

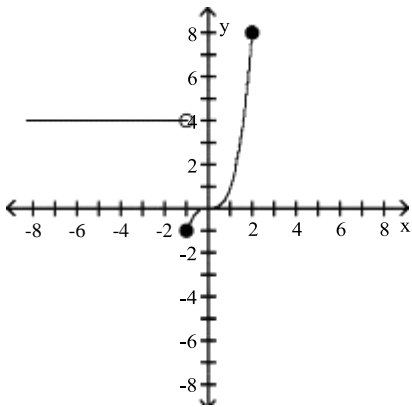

A)

$$f(x) = \begin{cases} 4 & \text{if } x < -1 \\ x^3 & \text{if } x \geq -1 \end{cases}$$

C)

$$f(x) = \begin{cases} 4 & \text{if } x < -1 \\ x^2 & \text{if } x \geq -1 \end{cases}$$

B)

$$f(x) = \begin{cases} 4 & \text{if } x < -1 \\ x^3 - 1 & \text{if } x \geq -1 \end{cases}$$

D)

$$f(x) = \begin{cases} -4 & \text{if } x < -1 \\ x^2 - 1 & \text{if } x \geq -1 \end{cases}$$

Answer: A

326)

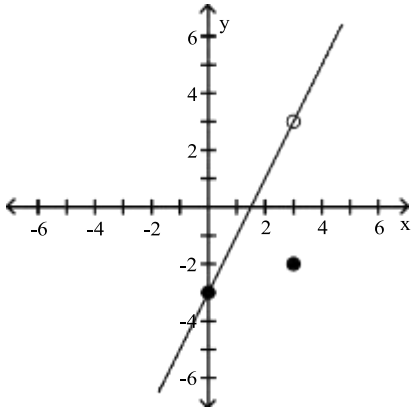

A)

$$f(x) = \begin{cases} x - 3 & \text{if } x \neq 3 \\ -2 & \text{if } x = 3 \end{cases}$$

C)

$$f(x) = \begin{cases} 2x - 3 & \text{if } x < 3 \\ 2x + 3 & \text{if } x > 3 \end{cases}$$

B)

$$f(x) = \begin{cases} 2x - 3 & \text{if } x \neq 3 \\ -2 & \text{if } x = 3 \end{cases}$$

D)

$$f(x) = \begin{cases} 2x - 3 & \text{if } x \neq 2 \\ -3 & \text{if } x = 2 \end{cases}$$

Answer: B

327)

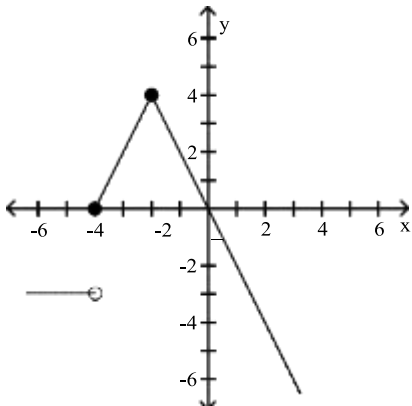

A)

$$f(x) = \begin{cases} -3x & \text{if } x < -4 \\ -2|x - 2| + 4 & \text{if } x \geq -4 \end{cases}$$

C)

$$f(x) = \begin{cases} -3 & \text{if } x \leq -4 \\ -2|x + 2| + 4 & \text{if } x > -4 \end{cases}$$

B)

$$f(x) = \begin{cases} -3 & \text{if } x < -4 \\ -2|x + 2| + 4 & \text{if } x \geq -4 \end{cases}$$

D)

$$f(x) = \begin{cases} -3x & \text{if } x < -4 \\ -2|x + 2| + 4 & \text{if } x \geq -4 \end{cases}$$

Answer: B

328)

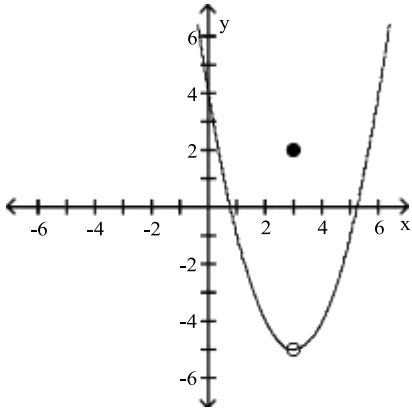

A)

$$f(x) = \begin{cases} (x-3)^2 - 5 & \text{if } x \neq 3 \\ 2 & \text{if } x = 3 \end{cases}$$

C) $f(x) = (x-3)^2 - 5$

B)

$$f(x) = \begin{cases} (x+3)^2 - 5 & \text{if } x \neq 3 \\ 2 & \text{if } x = 3 \end{cases}$$

D)

$$f(x) = \begin{cases} |x-3| - 5 & \text{if } x \neq 3 \\ 2 & \text{if } x = 3 \end{cases}$$

Answer: A

329)

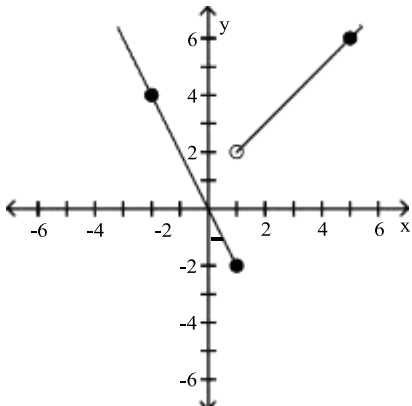

A)

$$f(x) = \begin{cases} 2x & \text{if } x \leq 1 \\ x+1 & \text{if } x > 1 \end{cases}$$

C)

$$f(x) = \begin{cases} -x & \text{if } x \leq 1 \\ 2x+1 & \text{if } x > 1 \end{cases}$$

B)

$$f(x) = \begin{cases} -2x & \text{if } x \leq 1 \\ x+1 & \text{if } x > 1 \end{cases}$$

D)

$$f(x) = \begin{cases} -2x & \text{if } x \leq 1 \\ x+2 & \text{if } x > 1 \end{cases}$$

Answer: B

Graph the equation.

135) $y = \lfloor x \rfloor + 1$

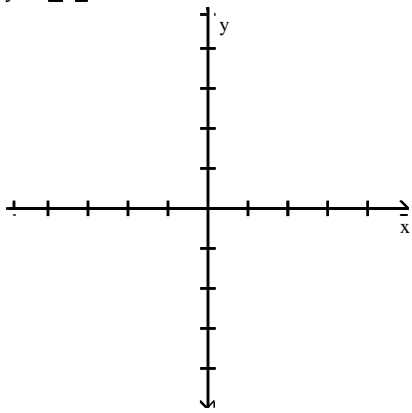

A)

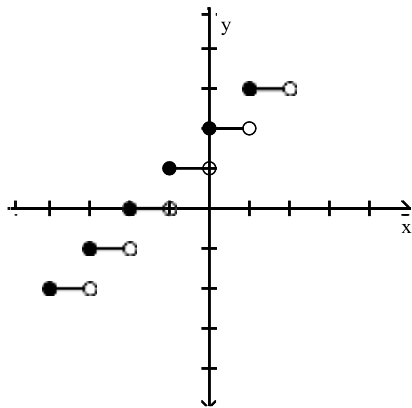

C)

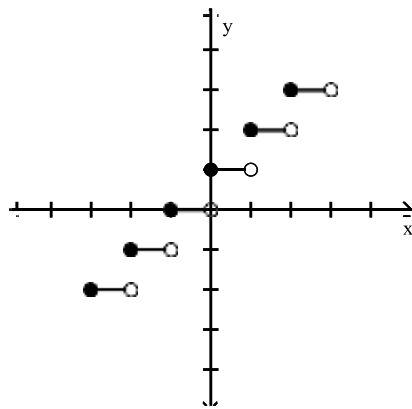

Answer: C

B)

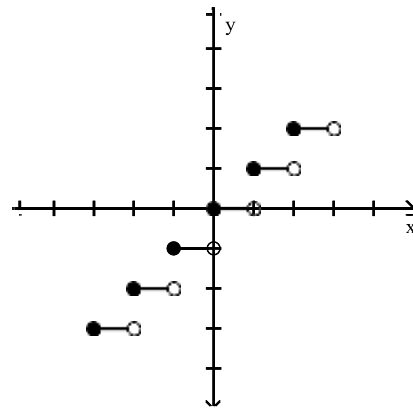

D)

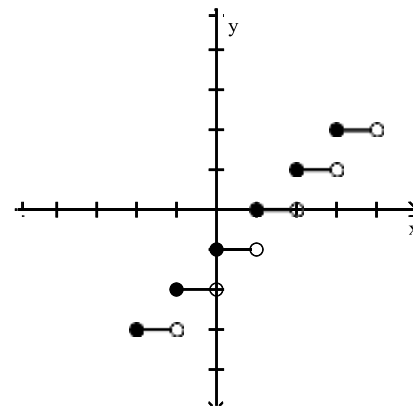

136) $y = \lfloor k + 1 \rfloor$

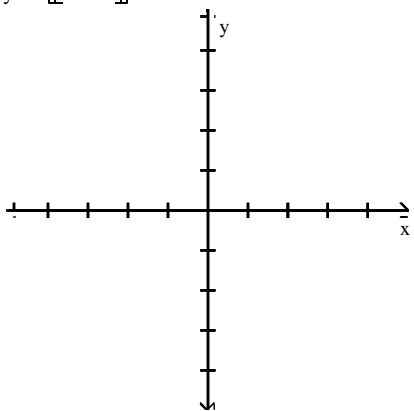

A)

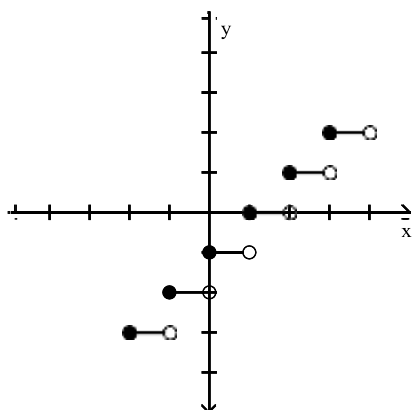

C)

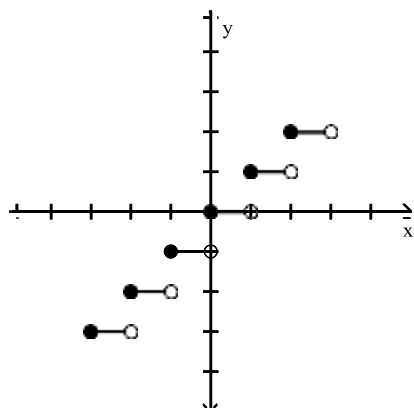

B)

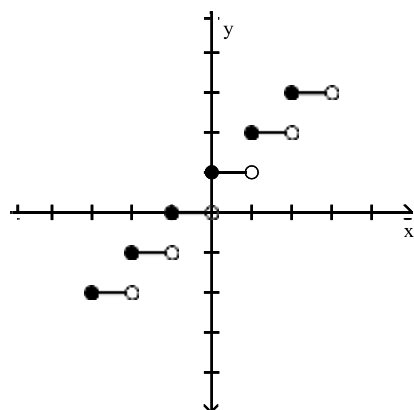

D)

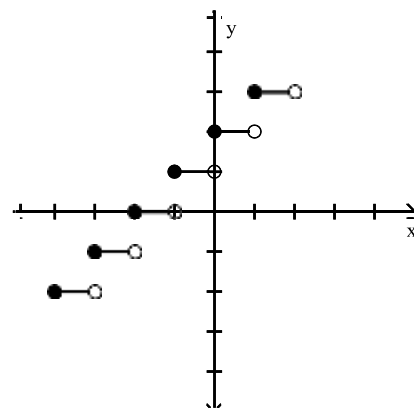

Answer: B

137) $y = \lceil x \rceil - 1$

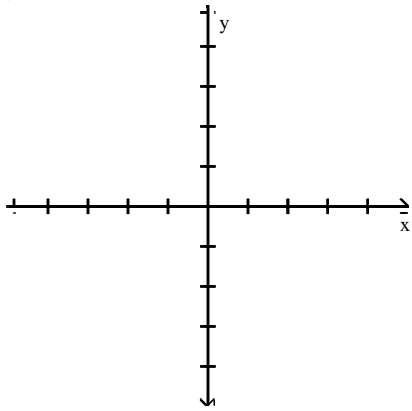

A)

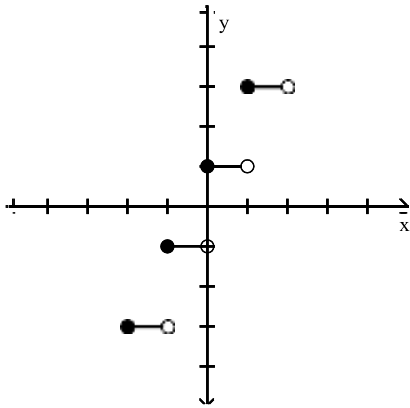

C)

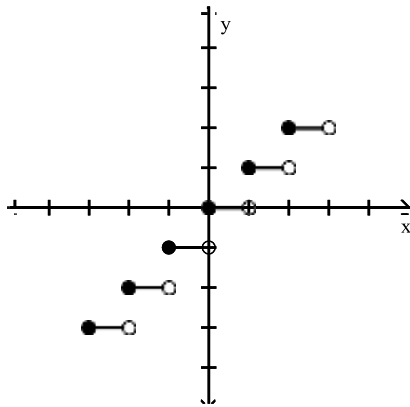

B)

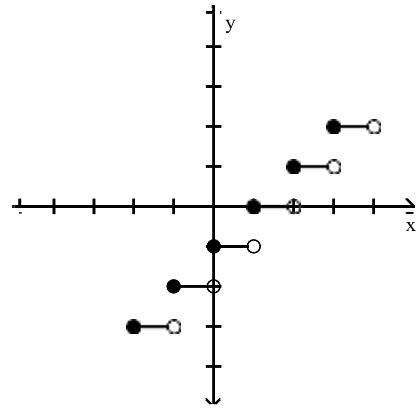

D)

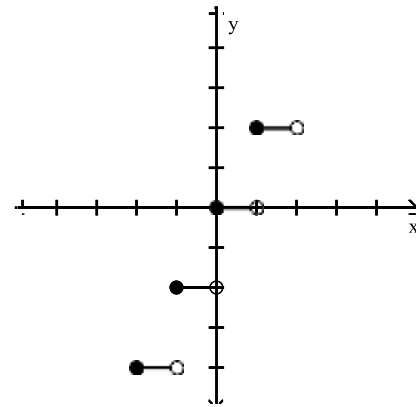

Answer: B

138) $y = \lfloor x - 1 \rfloor$

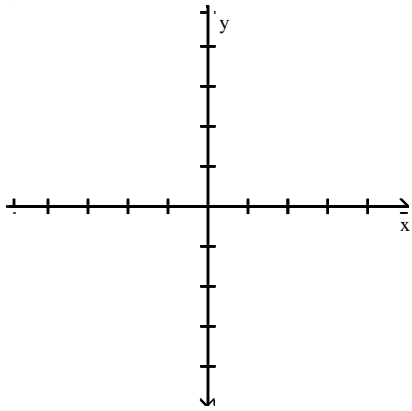

A)

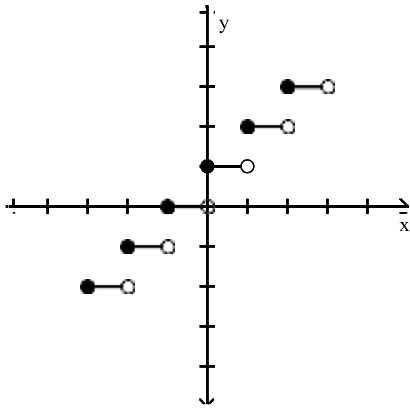

C)

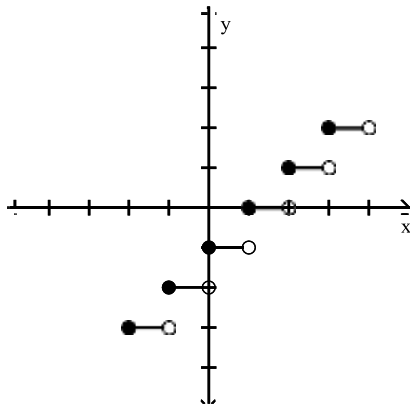

B)

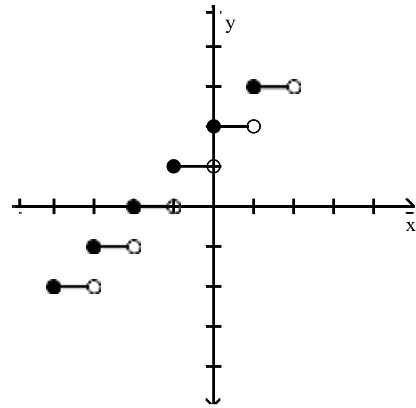

D)

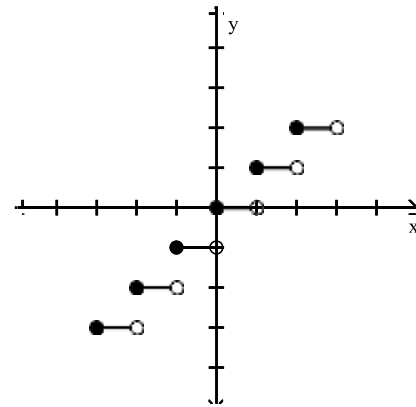

Answer: C

334) $y = 2\lceil x \rceil$

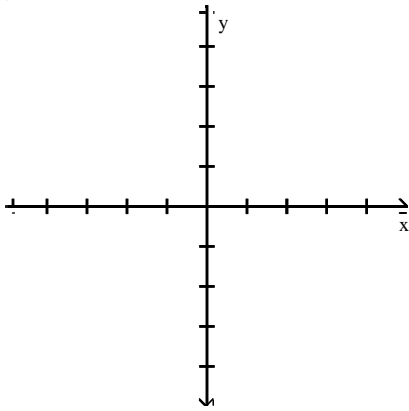

A)

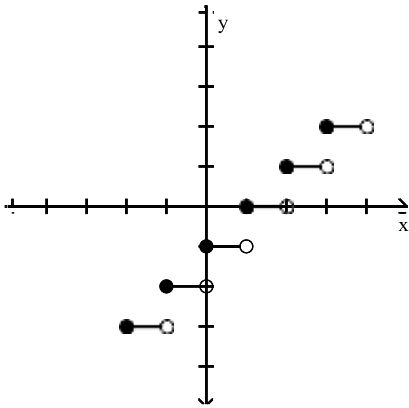

C)

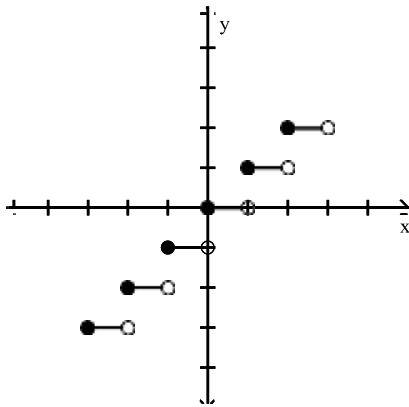

B)

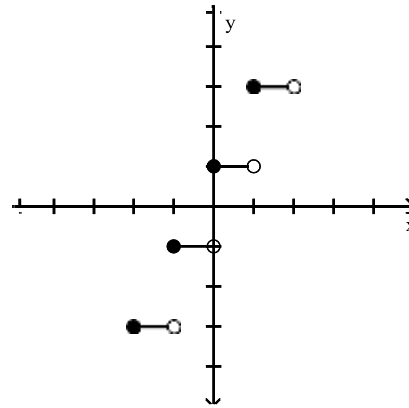

D)

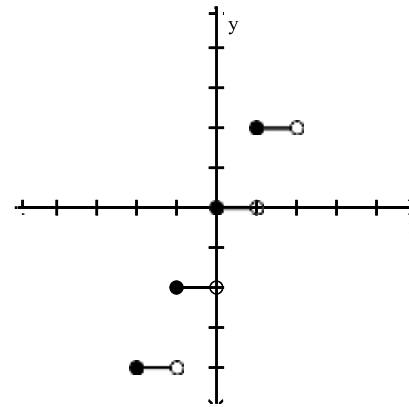

Answer: D

Solve the problem.

335) A video rental company charges \$3 per day for renting a video tape, and then \$2 per day after the first. Use the greatest integer function and write an expression for renting a video tape for x days.

A) $y = 2x + 3$

B) $y = 2\lceil x - 1 \rceil + 3$

C) $y + 3 = 2\lceil x \rceil$

D) $y = \lceil 2x + 3 \rceil$

Answer: B

336) Suppose a car rental company charges \$100 for the first day and \$50 for each additional or partial day. Let $S(x)$ represent the cost of renting a car for x days. Find the value of $S(5.5)$.

A) \$275

B) \$350

C) \$325

D) \$375

Answer: B

- 337) Suppose a life insurance policy costs \$28 for the first unit of coverage and then \$7 for each additional unit of coverage. Let $C(x)$ be the cost for insurance of x units of coverage. What will 10 units of coverage cost?
 A) \$70 B) \$42 C) \$98 D) \$91

Answer: D

- 338) A salesperson gets a commission of \$1000 for the first \$10,000 of sales, and then \$500 for each additional \$10,000 or partial of sales. Let $S(x)$ represent the commission on x dollars of sales. Find the value of $S(65,000)$.
 A) \$3750 B) \$4250 C) \$4000 D) \$3250

Answer: C

- 339) Assume it costs 25 cents to mail a letter weighing one ounce or less, and then 20 cents for each additional ounce or fraction of an ounce. Let $L(x)$ be the cost of mailing a letter weighing x ounces. Graph $y = L(x)$.

A)

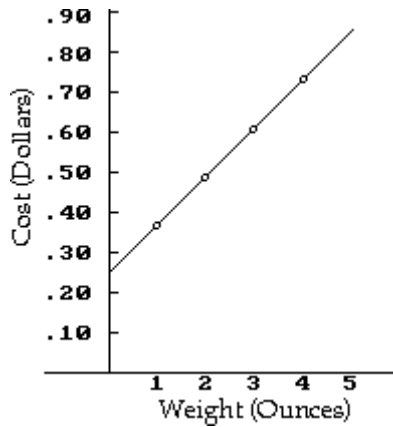

B)

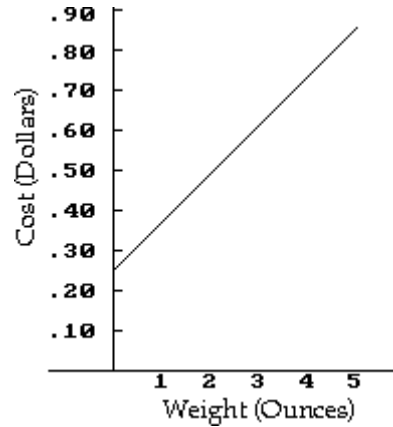

C)

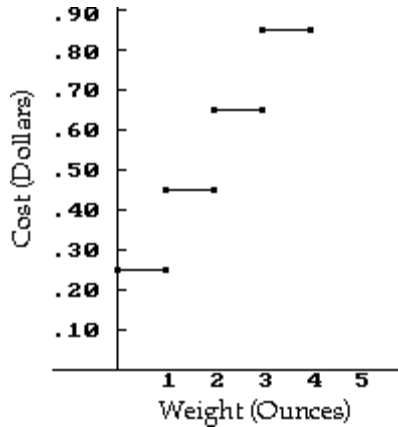

D)

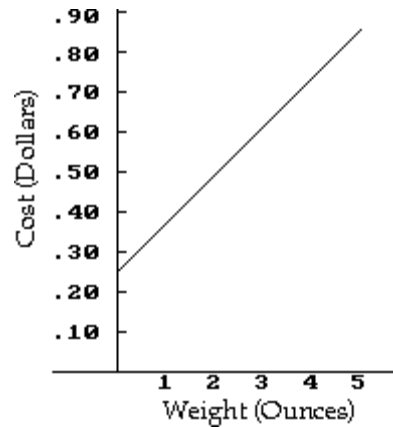

Answer: D

340) Sketch a graph that depicts the amount of water in a 50-gallon tank during the course of the described pumping operations. The tank is initially full, and then a pump is used to take water out of the tank at a rate of 6 gallons per minute. The pump is turned off after 5 minutes. At that point, the pump is changed to one that will pump water into the tank. The change takes 2 minutes and the water level is unchanged during the switch. Then, water is pumped into the tank at a rate of 4 gallons per minute for 3 minutes.

A)

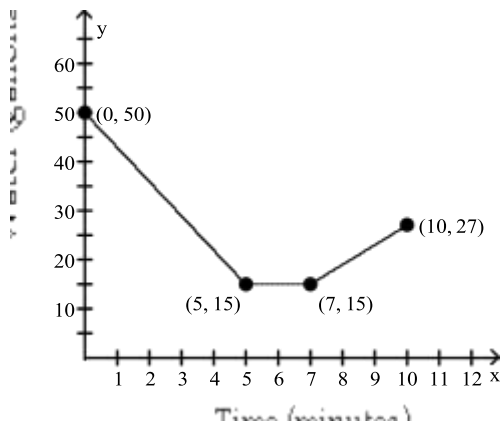

B)

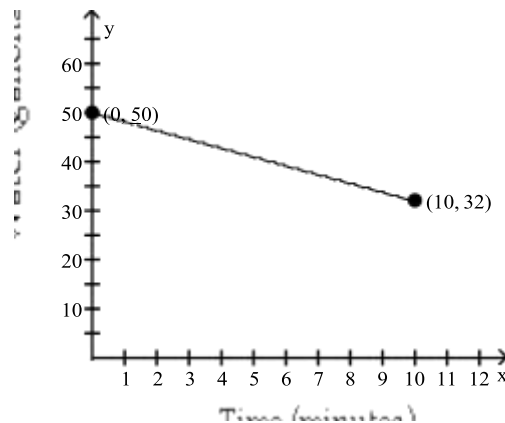

C)

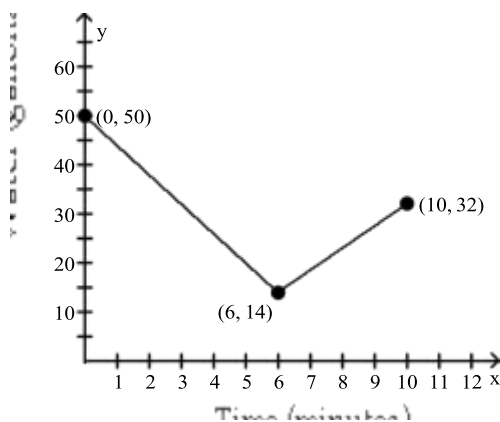

D)

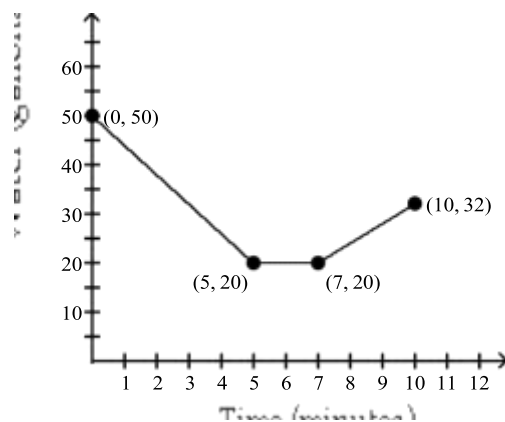

Answer: D

341) The charges for renting a moving van are \$55 for the first 30 miles and \$4 for each additional mile. Assume that a fraction of a mile is rounded up. (i) Determine the cost of driving the van 77 miles. (ii) Find a symbolic representation for a function f that computes the cost of driving the van x miles, where $0 < x \leq 100$. (Hint: express f as a piecewise-constant function.)

A) \$243;

$$f(x) = \begin{cases} 55 & \text{if } 0 < x \leq 30 \\ 55 + 4(x - 30) & \text{if } 30 < x \leq 100 \end{cases}$$

C) \$243;

$$f(x) = \begin{cases} 55 & \text{if } 0 < x \leq 30 \\ 55 + 4(x + 30) & \text{if } 30 < x \leq 100 \end{cases}$$

B) \$483;

$$f(x) = \begin{cases} 55 & \text{if } 0 < x \leq 30 \\ 55 + 4(x + 30) & \text{if } 30 < x \leq 100 \end{cases}$$

D) \$4423;

$$f(x) = \begin{cases} 55 & \text{if } 0 < x \leq 30 \\ 55 + 4(x - 30) & \text{if } 30 < x \leq 100 \end{cases}$$

Answer: A

342) Sketch a graph showing the mileage that a person is from home after x hours if that individual drives at 30 mph to a lake 60 miles away, stays at the lake 1.5 hours, and then returns home at a speed of 60 mph.

A)

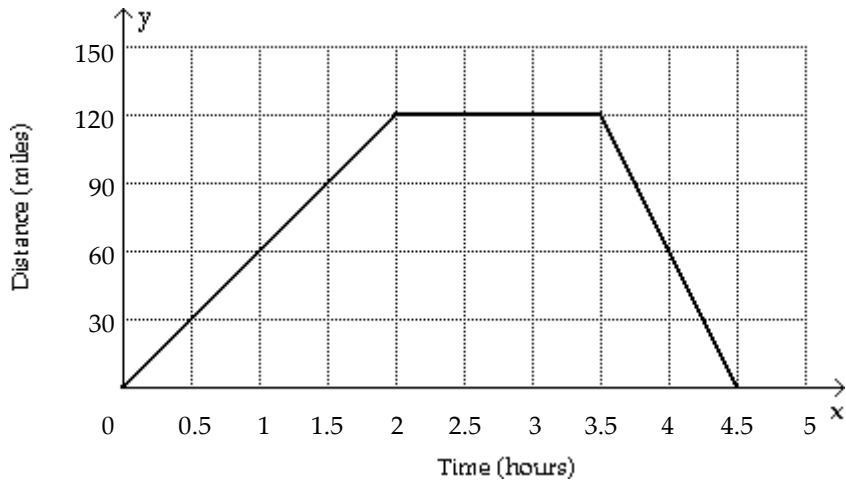

B)

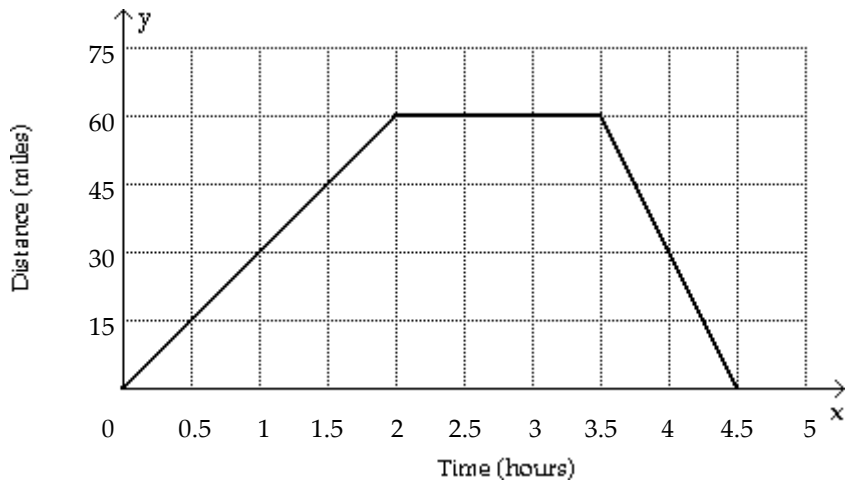

C)

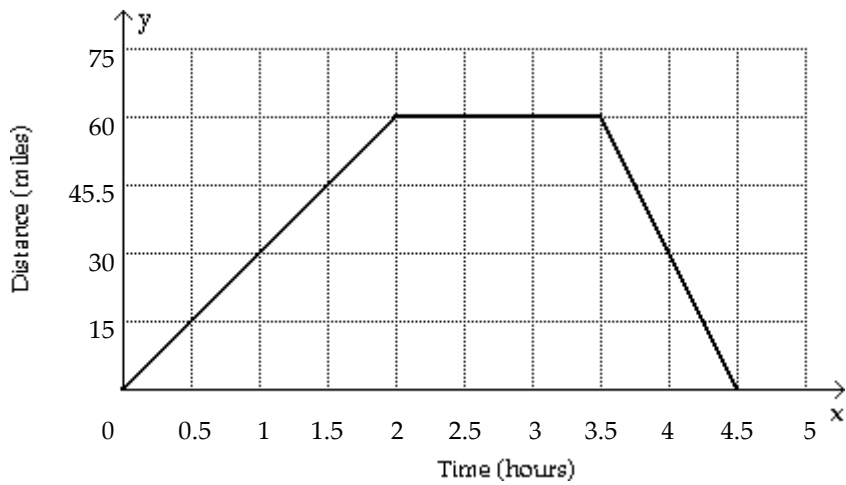

Answer: B

343) In Country X, the average hourly wage in dollars from 1945 to 1995 can be modeled by

$$f(x) = \begin{cases} 0.076(x - 1945) + 0.31 & \text{if } 1945 \leq x < 1970 \\ 0.182(x - 1970) + 3.07 & \text{if } 1970 \leq x \leq 1995 \end{cases}$$

Use f to estimate the average hourly wages in 1950, 1970, and 1990.

- A) \$0.69, \$2.21, \$6.71 B) \$0.69, \$3.07, \$6.71 C) \$3.45, \$6.71, \$2.21 D) \$3.45, \$0.31, \$6.71

Answer: B

Provide an appropriate response.

344) Which of the following is a vertical translation of the function $y = \lfloor x \rfloor$?

- A) $y = -\lfloor x \rfloor$ B) $y = \lfloor x - 6 \rfloor$ C) $y = \lfloor x \rfloor - 6$ D) $y = 6\lfloor x \rfloor$

Answer: C

345) Which of the following is a horizontal translation of the function $y = \lfloor x \rfloor$?

- A) $y = -\lfloor x \rfloor$ B) $y = 7\lfloor x \rfloor$ C) $y = \lfloor x \rfloor - 7$ D) $y = \lfloor x - 7 \rfloor$

Answer: D

346) Which of the following is a reflection of the function $y = \lfloor x \rfloor$ about the y -axis? Use your graphics calculator to verify your result.

- A) $y = -\lfloor x + 1 \rfloor$ B) $y = \lfloor -x + 1 \rfloor$ C) $y = \lfloor -x \rfloor$ D) $y = -\lfloor x \rfloor$

Answer: C

Find the requested composition or operation.

347) $f(x) = 6 - 8x$, $g(x) = -4x + 8$

Find $(f + g)(x)$.

- A) $-4x + 6$ B) $2x$ C) $-12x + 14$ D) $-4x + 14$

Answer: C

348) $f(x) = 7x - 6$, $g(x) = 3x - 4$

Find $(f - g)(x)$.

- A) $-4x + 2$ B) $4x - 10$ C) $10x - 10$ D) $4x - 2$

Answer: D

349) $f(x) = \sqrt{4x + 4}$, $g(x) = \sqrt{4x - 9}$

Find $(fg)(x)$.

- A) $(\sqrt{4x + 4})(\sqrt{4x - 9})$ B) $(2x - 3)(\sqrt{4x + 4})$ C) $(4x + 4)(2x - 3)$ D) $(4x + 4)(4x - 9)$

Answer: A

350) $f(x) = 9x - 3$, $g(x) = 2x + 8$

Find $(fg)(x)$.

- A) $11x^2 + 66x + 5$ B) $18x^2 + 66x - 24$ C) $18x^2 + 2x - 24$ D) $18x^2 - 24$

Answer: B

351) $f(x) = 4x^2 - 9x$, $g(x) = x^2 - 3x - 54$

Find $\left(\frac{f}{g}\right)(x)$.

A) $\frac{4x-9}{-3}$

B) $\frac{4x}{x+1}$

C) $\frac{4x^2-9x}{x^2-3x-54}$

D) $\frac{4-x}{54}$

Answer: C

352) $f(x) = 3x + 10$, $g(x) = 2x - 1$

Find $(f \circ g)(x)$.

A) $6x + 9$

B) $6x + 19$

C) $6x + 13$

D) $6x + 7$

Answer: D

353) $f(x) = \sqrt{x+5}$, $g(x) = 8x - 9$

Find $(f \circ g)(x)$.

A) $2\sqrt{2x-1}$

B) $8\sqrt{x+5} - 9$

C) $2\sqrt{2x+1}$

D) $8\sqrt{x-4}$

Answer: A

354) $f(x) = 4x^2 + 2x + 4$, $g(x) = 2x - 5$

Find $(g \circ f)(x)$.

A) $8x^2 + 4x + 13$

B) $4x^2 + 4x + 3$

C) $8x^2 + 4x + 3$

D) $4x^2 + 2x - 1$

Answer: C

355) $f(x) = \frac{3}{x-7}$, $g(x) = \frac{5}{3x}$

Find $(f \circ g)(x)$.

A) $\frac{3x}{5-21x}$

B) $\frac{9x}{5+21x}$

C) $\frac{9x}{5-21x}$

D) $\frac{5x-35}{9x}$

Answer: C

356) $f(x) = \frac{x-2}{5}$, $g(x) = 5x + 2$

Find $(g \circ f)(x)$.

A) $5x + 8$

B) $x - \frac{2}{5}$

C) $x + 4$

D) x

Answer: D

Perform the requested composition or operation.

357) Find $(f + g)(4)$ when $f(x) = x - 1$ and $g(x) = x + 2$.

A) 5

B) 7

C) 11

D) 9

Answer: D

358) Find $(f - g)(-5)$ when $f(x) = -4x^2 - 1$ and $g(x) = x - 4$.

A) -102

B) 106

C) -100

D) -92

Answer: D

- 359) Find $(fg)(4)$ when $f(x) = x - 2$ and $g(x) = -3x^2 + 15x + 1$.
 A) 78 B) -282 C) 26 D) 154
 Answer: C

- 360) Find $\left\{\frac{f}{g}\right\}(-5)$ when $f(x) = 3x - 2$ and $g(x) = 2x^2 + 14x + 3$.
 A) 1 B) 0 C) $\frac{2}{13}$ D) $-\frac{2}{17}$

Answer: A

- 361) Find $(f \circ g)(-4)$ when $f(x) = 6x + 8$ and $g(x) = 9x^2 - 5x - 1$.
 A) -94 B) 986 C) -65 D) 2383
 Answer: B

- 362) Find $(g \circ f)(9)$ when $f(x) = -3x + 3$ and $g(x) = 8x^2 - 2x - 9$.
 A) 4647 B) -153 C) -132 D) -1860
 Answer: A

Find the specified domain.

- 363) For $f(x) = 2x - 5$ and $g(x) = \sqrt{x + 6}$, what is the domain of $(f + g)$?
 A) $[0, \infty)$ B) $[-6, \infty)$ C) $[6, \infty)$ D) $(-6, 6)$
 Answer: B

- 364) For $f(x) = 2x - 5$ and $g(x) = \sqrt{x + 4}$, what is the domain of $\left\{\frac{f}{g}\right\}$?
 A) $[0, \infty)$ B) $(-4, \infty)$ C) $[4, \infty)$ D) $(-4, 4)$
 Answer: B

- 365) For $f(x) = 2x - 5$ and $g(x) = \sqrt{x + 2}$, what is the domain of $(f \circ g)$?
 A) $[0, \infty)$ B) $[2, \infty)$ C) $[-2, \infty)$ D) $(-2, 2)$
 Answer: C

- 366) For $f(x) = 2x - 5$ and $g(x) = \sqrt{x + 8}$, what is the domain of $(g \circ f)$?
 A) $[8, \infty)$ B) $(-8, 8)$ C) $[\infty, -1.5)$ D) $[-1.5, \infty)$
 Answer: D

- 367) For $f(x) = x^2 - 36$ and $g(x) = 2x + 3$, what is the domain of $(f - g)$?
 A) $[0, \infty)$ B) $(-\infty, \infty)$ C) $(-6, 6)$ D) $[6, \infty)$
 Answer: B

- 368) For $f(x) = x^2 - 9$ and $g(x) = 2x + 3$, what is the domain of $\left\{\frac{f}{g}\right\}$?
 A) $\left(-\infty, -\frac{3}{2}\right) \cup \left(-\frac{3}{2}, \infty\right)$ B) $(-\infty, \infty)$ C) $(-3, 3)$ D) $\left[-\frac{3}{2}, \infty\right)$

Answer: A

369) For $f(x) = x^2 - 49$ and $g(x) = 2x + 3$, what is the domain of $\left(\frac{g}{f}\right)$

A) $\left(-\infty, \frac{3}{2}\right) \cup \left(-\frac{3}{2}, \infty\right)$
 C) $\left[-\frac{3}{2}, \infty\right)$

B) $(-\infty, \infty)$

D) $(-\infty, -7) \cup (-7, 7) \cup (7, \infty)$

Answer: D

370) For $f(x) = x^2 - 81$ and $g(x) = 2x + 3$, what is the domain of $(f \circ g)$?

A) $[0, \infty)$

B) $(-\infty, \infty)$

C) $(-9, 9)$

D) $[9, \infty)$

Answer: B

371) For $f(x) = \sqrt{x-2}$ and $g(x) = \frac{1}{-9}$, what is the domain of $(f \cdot g)$?

A) $(2, 9) \cup (9, \infty)$

B) $[2, 9) \cup (9, \infty)$

C) $[2, \infty)$

D) $[0, 9) \cup (9, \infty)$

Answer: B

372) For $g(x) = \sqrt{x+1}$ and $h(x) = \frac{1}{x-7}$, what is the domain of $(h \circ g)$?

A) $[-1, 7) \cup (7, \infty)$

B) $[0, 48) \cup (48, \infty)$

C) $[0, 7) \cup (7, \infty)$

D) $[-1, 48) \cup (48, \infty)$

Answer: D

Use the graphs to evaluate the expression.

373) $f(-1) + g(0)$

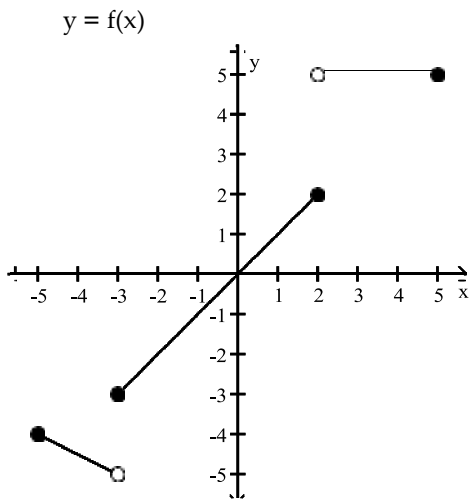

A) -4

B) -2

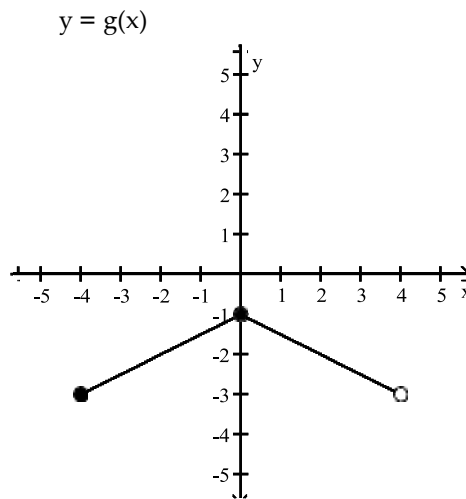

C) -1

D) 1

Answer: B

374) $f(-2) - g(0)$

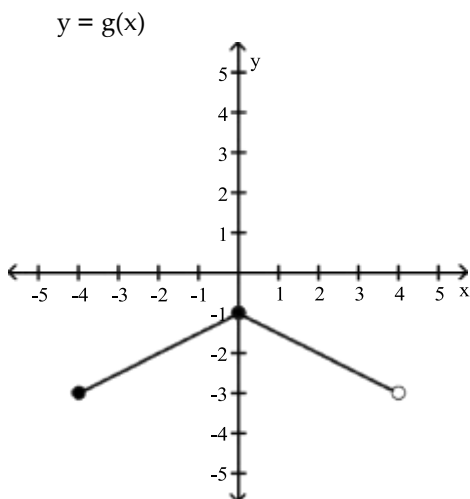
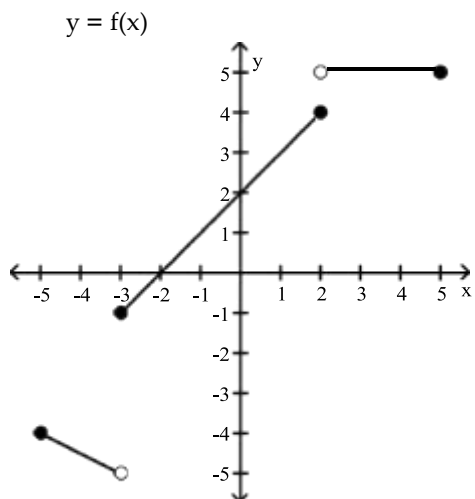

A) 4

B) 1

C) -2

D) 0

Answer: B

375) $f(-2) - g(4)$

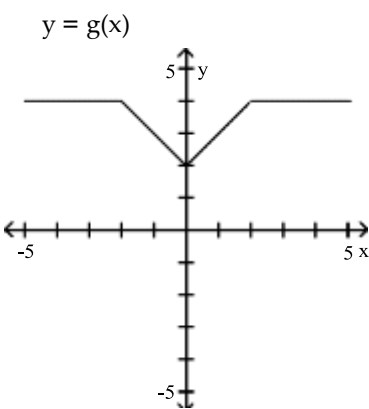
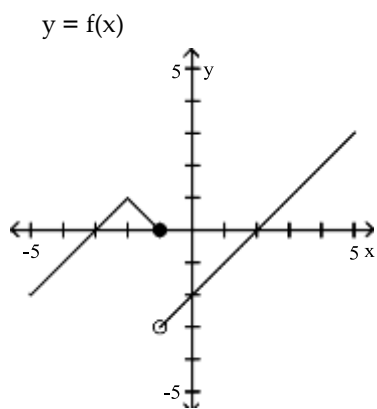

A) -3

B) 5

C) 4

D) $\frac{1}{4}$

Answer: A

376) $f(4) \cdot g(-3)$

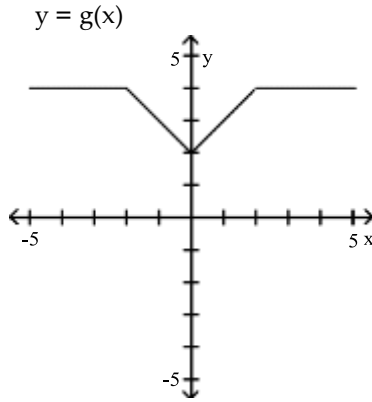
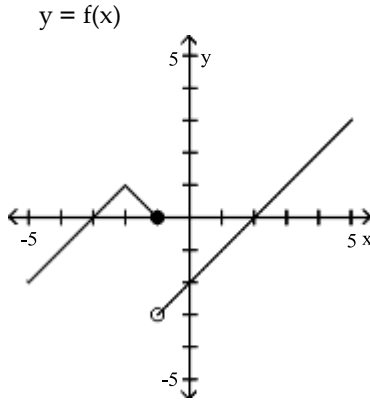

A) 6

B) $\frac{1}{2}$

C) 8

D) -2

Answer: C

377) $(g \circ f)(-2)$

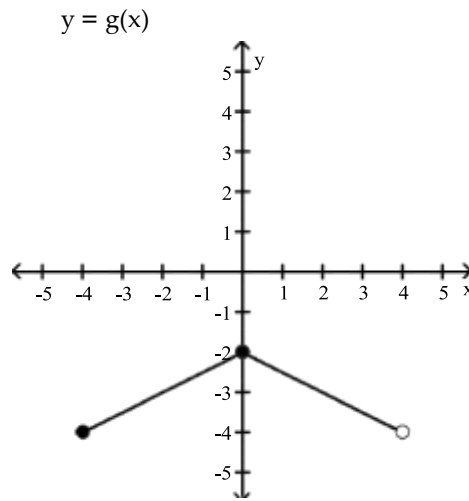
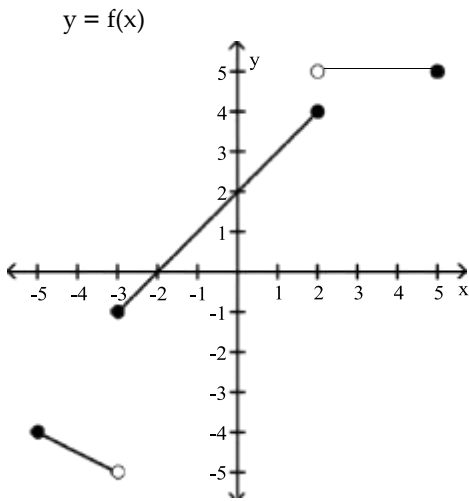

A) -1

B) -2

C) -3.5

D) -5

Answer: B

378) $(f \circ g)(0)$

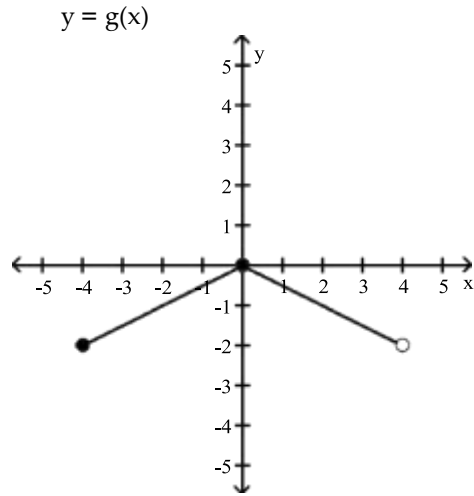
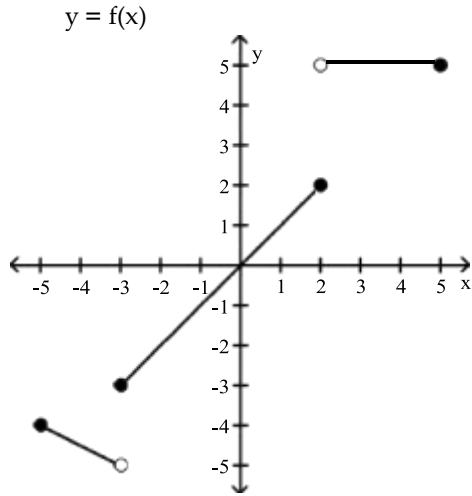

A) 0

B) -1.5

C) 1

D) -2

Answer: A

379) $(f \circ g)(0)$

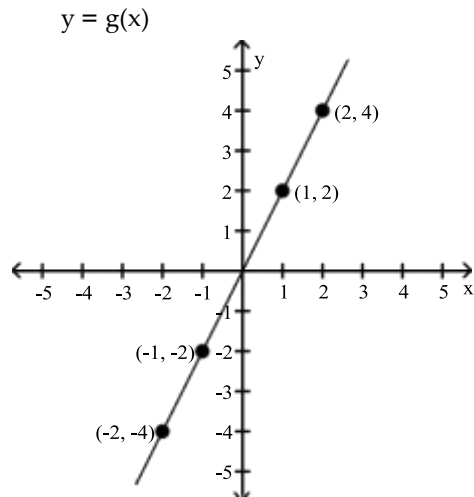
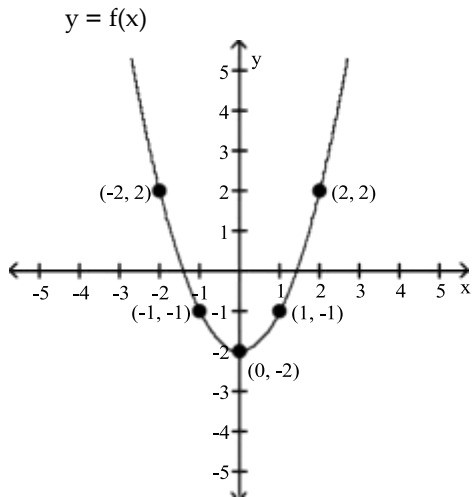

A) -1

B) 1

C) -2

D) -3

Answer: C

380) $(g \circ f)(1)$

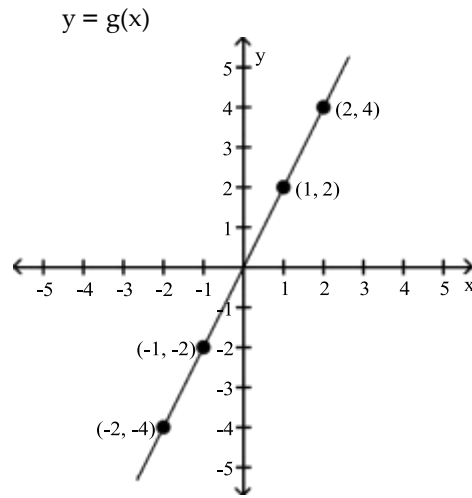
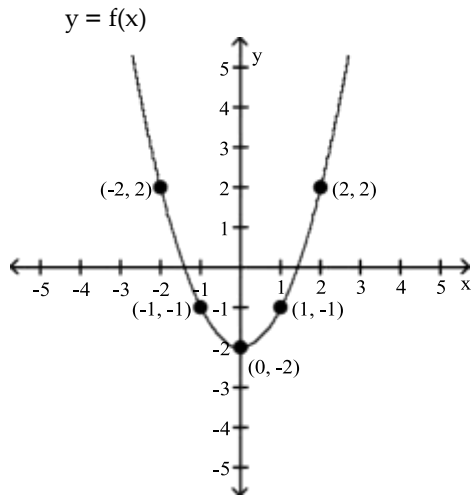

A) -2

B) -3

C) -4

D) -1

Answer: A

381) $(f + g)(1)$

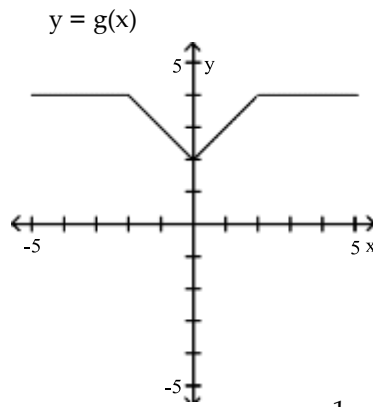
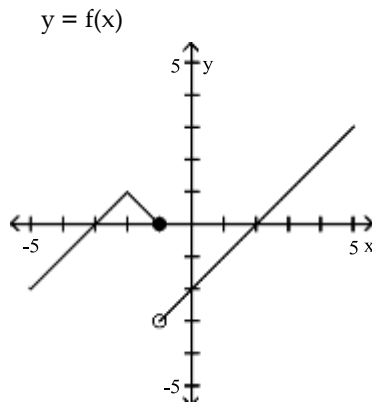

A) 2

B) -3

C) $-\frac{1}{3}$

D) -4

Answer: A

382) $g(f(1))$

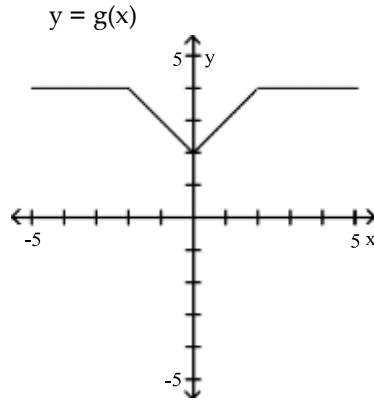
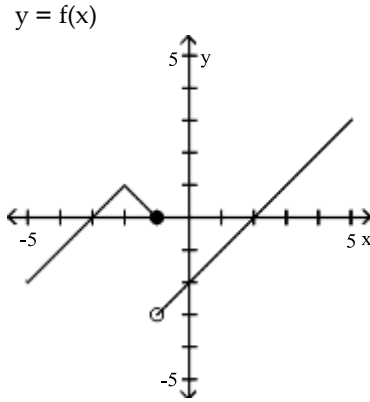

A) -3

B) -4

C) 2

D) 3

Answer: D

Use the tables to evaluate the expression if possible.

383) Find $(f + g)(-3)$.

x	-3	-2	5
$f(x)$	8	-1	-4

x	-3	1	5
$g(x)$	-2	-2	6

A) 10

B) 6

C) -3

D) 2

Answer: B

384) Find $(fg)(-4)$.

x	-4	-1	7
$f(x)$	-7	-2	6

x	-4	4	7
$g(x)$	-8	8	7

A) 16

B) 42

C) -16

D) 56

Answer: D

385) Find $(g \circ f)(6)$.

x	2	4	6
$f(x)$	4	16	36

x	16	36	9	4	25
$g(x)$	2	22	-5	-10	11

A) 14

B) -7

C) 2

D) 22

Answer: D

386) Find $(f \cdot g)(7)$.

x	19	15	11	13
$f(x)$	38	30	22	26

x	9	7	10	8
$g(x)$	17	13	19	15

A) 7

B) 13

C) 26

D) 30

Answer: C

387) Find $(g \circ f)(5)$.

x	5	8	6	12
f(x)	6	10	25	27

x	7	12	5	6
g(x)	13	9	12	11

A) 11

B) 25

C) 5

D) 9

Answer: A

388) Find $(f \circ f)(7)$.

x	7	10	8	6
f(x)	8	7	37	39

x	9	7	10	8
g(x)	17	13	19	15

A) 37

B) 7

C) 15

D) 19

Answer: A

389) Find $(g \circ g)(4)$.

x	4	7	5	10
f(x)	5	8	19	21

x	6	10	4	5
g(x)	11	7	10	9

A) 7

B) 19

C) 9

D) 21

Answer: A

Determine whether $(f \circ g)(x) = x$ and whether $(g \circ f)(x) = x$.

390) $f(x) = \sqrt[5]{x-12}$, $g(x) = x^5 + 12$

A) No, no

B) Yes, no

C) Yes, yes

D) No, yes

Answer: C

391) $f(x) = x^2 + 4$, $g(x) = \sqrt{x} - 4$

A) Yes, yes

B) Yes, no

C) No, yes

D) No, no

Answer: D

392) $f(x) = \frac{1}{x}$, $g(x) = x$

A) Yes, yes

B) Yes, no

C) No, no

D) No, yes

Answer: C

393) $f(x) = \sqrt{x+1}$, $g(x) = x^2$

A) No, yes

B) Yes, yes

C) No, no

D) Yes, no

Answer: C

394) $f(x) = x^3 + 3$, $g(x) = \sqrt[3]{x-3}$

A) Yes, no

B) Yes, yes

C) No, no

D) No, yes

Answer: B

Determine the difference quotient $\frac{f(x+h) - f(x)}{h}$ ($h \neq 0$) for the function f . Simplify completely.

395) $f(x) = 4x - 12$

A) $-4h$

B) 4

C) 12

D) 3

Answer: B

396) $f(x) = 6x^2 + 5x - 3$

A) $12x + 5 + 6h$

B) $12x + 5$

C) $6x + 6 + 12h$

D) $12xh + 5h + 5h^2$

Answer: A

397) $f(x) = 6 - 6x^3$

A) $-6(3x^2 - 3x - h)$

B) $-18x^2$

C) $-6(3x^2 + 3xh + h^2)$

D) $-6(x^2 - xh - h^2)$

Answer: C

Consider the function h as defined. Find functions f and g such that $(f \circ g)(x) = h(x)$.

398) $h(x) = \frac{1}{x^2 - 2}$

A) $f(x) = \frac{1}{2}, g(x) = x^2 - 2$

B) $f(x) = \frac{-1}{x^2}, g(x) = -\frac{1}{2}$

C) $f(x) = \frac{1}{x^2}, g(x) = x - 2$

D) $f(x) = \frac{1}{x}, g(x) = x^2 - 2$

Answer: D

399) $h(x) = |4x + 1|$

A) $f(x) = |x|, g(x) = 4x + 1$

B) $f(x) = -|x|, g(x) = 4x + 1$

C) $f(x) = x, g(x) = 4x + 1$

D) $f(x) = |-x|, g(x) = 4x - 1$

Answer: A

400) $h(x) = \frac{8}{x^2} + 10$

A) $f(x) = x, g(x) = \frac{8}{x} + 10$

B) $f(x) = \frac{1}{x}, g(x) = \frac{8}{x} + 10$

C) $f(x) = x + 10, g(x) = \frac{8}{x^2}$

D) $f(x) = \frac{8}{x^2}, g(x) = 10$

Answer: C

401) $h(x) = \frac{8}{\sqrt{2x + 10}}$

A) $f(x) = 8, g(x) = \sqrt{2x + 10}$

B) $f(x) = \sqrt{2x + 10}, g(x) = 8$

C) $f(x) = \frac{8}{\sqrt{x}}, g(x) = 2x + 10$

D) $f(x) = \frac{8}{x}, g(x) = 2x + 10$

Answer: C

402) $h(x) = (-5x - 3)^3$

A) $f(x) = (-5x)^3, g(x) = -3$

C) $f(x) = -5x - 3, g(x) = x^3$

B) $f(x) = x^3, g(x) = -5x - 3$

D) $f(x) = -5x^3, g(x) = x - 3$

Answer: B

403) $h(x) = \sqrt{-37x^2 + 11}$

A) $f(x) = -37x^2 + 11, g(x) = \sqrt{x}$

C) $f(x) = \sqrt{-37x + 11}, g(x) = x^2$

B) $f(x) = \sqrt{x}, g(x) = -37x^2 + 11$

D) $f(x) = \sqrt{-37x^2}, g(x) = \sqrt{11}$

Answer: B

Solve the problem.

404) Regrind, Inc. regrinds used typewriter platens. The cost to buy back each used platen is \$2.00. The fixed cost to run the grinding machine is \$249 per day. If the company sells the reground platens for \$5.00, how many must be reground daily to break even?

A) 124 platens

B) 35 platens

C) 83 platens

D) 55 platens

Answer: C

405) Northwest Molded molds plastic handles which cost \$0.20 per handle to mold. The fixed cost to run the molding machine is \$2117 per week. If the company sells the handles for \$1.20 each, how many handles must be molded weekly to break even?

A) 1512 handles

B) 2117 handles

C) 10,585 handles

D) 1411 handles

Answer: B

406) Midtown Delivery Service delivers packages which cost \$1.90 per package to deliver. The fixed cost to run the delivery truck is \$120 per day. If the company charges \$6.90 per package, how many packages must be delivered daily to break even?

A) 13 packages

B) 16 packages

C) 63 packages

D) 24 packages

Answer: D

407) A lumber yard has fixed costs of \$3466.00 a day and marginal costs of \$0.80 per board-foot produced. The company gets \$1.80 per board-foot sold. How many board-feet must be produced daily to break even?

A) 1333 board-feet

B) 4332 board-feet

C) 2310 board-feet

D) 3466 board-feet

Answer: D

408) Midtown Delivery Service delivers packages which cost \$1.90 per package to deliver. The fixed cost to run the delivery truck is \$415 per day. If the company charges \$6.90 per package, how many packages must be delivered daily to make a profit of \$90?

A) 101 packages

B) 218 packages

C) 83 packages

D) 47 packages

Answer: A

409) The cost of manufacturing clocks is given by $C(x) = 80 + 57x - x^2$. Also, it is known that in t hours the number of clocks that can be produced is given by $x = 5t$, where $1 \leq t \leq 12$. Express C as a function of t .

A) $C(t) = 80 + 285t - 25t$

B) $C(t) = 80 + 57t + t^2$

C) $C(t) = 80 + 285t - 25t^2$

D) $C(t) = 80 + 57t - 5$

Answer: C

410) At Allied Electronics, production has begun on the X-15 Computer Chip. The total revenue function is given by $R(x) = 52x - 0.3x^2$ and the total cost function is given by $C(x) = 3x + 11$, where x represents the number of boxes of computer chips produced. The total profit function, $P(x)$, is such that $P(x) = R(x) - C(x)$. Find $P(x)$.

A) $P(x) = 0.3x^2 + 46x - 33$

B) $P(x) = -0.3x^2 + 46x + 11$

C) $P(x) = -0.3x^2 + 49x - 11$

D) $P(x) = 0.3x^2 + 49x - 22$

Answer: C

411) At Allied Electronics, production has begun on the X-15 Computer Chip. The total revenue function is given by $R(x) = 44x - 0.3x^2$ and the total profit function is given by $P(x) = -0.3x^2 + 41x - 16$, where x represents the number of boxes of computer chips produced. The total cost function, $C(x)$, is such that $C(x) = R(x) - P(x)$. Find $C(x)$.

A) $C(x) = 4x + 21$

B) $C(x) = 5x + 12$

C) $C(x) = 3x + 16$

D) $C(x) = -0.3x^2 + 6x + 16$

Answer: C

412) At Allied Electronics, production has begun on the X-15 Computer Chip. The total cost function is given by $C(x) = 4x + 9$ and the total profit function is given by $P(x) = -0.3x^2 + 49x - 9$, where x represents the number of boxes of computer chips produced. The total revenue function, $R(x)$, is such that $R(x) = C(x) + P(x)$. Find $R(x)$.

A) $R(x) = 53x + 0.3x^2$

B) $R(x) = 53x - 0.3x^2$

C) $R(x) = 55x - 0.3x^2$

D) $R(x) = 52x - 0.6x^2$

Answer: B

413) The radius r of a circle of known area A is given by $r = \sqrt{A/\pi}$, where $\pi \approx 3.1416$. Find the radius and circumference of a circle with an area of 46.12 sq ft. (Round results to two decimal places.)

A) $r = 14.67$ ft, $C = 92.17$ ft

B) $r = 3.83$ ft, $C = 8.86$ ft

C) $r = 3.83$ ft, $C = 24.06$ sq ft

D) $r = 3.83$ ft, $C = 24.06$ ft

Answer: D

414) The volume of water added to a circular drum of radius r is given by $V_W = 15t$, where V_W is volume in cu ft and t is time in sec. Find the depth of water in a drum of radius 2 ft after adding water for 3 sec. (Round result to one decimal place.)

A) 3.6 ft

B) 1.9 ft

C) 7.2 ft

D) 11.3 ft

Answer: A

415) A retail store buys 55 VCRs from a distributor at a cost of \$150 each plus an overhead charge of \$30 per order. The retail markup is 25% on the total price paid. Find the profit on the sale of one VCR.

A) \$37.36

B) \$37.50

C) \$3764.00

D) \$37.64

Answer: D

416) A balloon (in the shape of a sphere) is being inflated. The radius is increasing at a rate of 14 cm per second. Find a function, $r(t)$, for the radius in terms of t . Find a function, $V(r)$, for the volume of the balloon in terms of r . Find $(V \cdot r)(t)$.

A) $(V \cdot r)(t) = \frac{153664\pi\sqrt{t}}{3}$

B) $(V \cdot r)(t) = \frac{10976\pi t^3}{3}$

C) $(V \cdot r)(t) = \frac{13720\pi t^2}{3}$

D) $(V \cdot r)(t) = \frac{1372\pi t^3}{3}$

Answer: B

417) A stone is thrown into a pond. A circular ripple is spreading over the pond in such a way that the radius is increasing at the rate of 2.3 feet per second. Find a function, $r(t)$, for the radius in terms of t . Find a function, $A(r)$, for the area of the ripple in terms of r . Find $(A \circ r)(t)$.

A) $(A \circ r)(t) = 2.3\pi t^2$ B) $(A \circ r)(t) = 5.29\pi t^2$ C) $(A \circ r)(t) = 5.29\pi^2 t$ D) $(A \circ r)(t) = 4.6\pi t^2$

Answer: B

418) Ken is 6 feet tall and is walking away from a streetlight. The streetlight has its light bulb 14 feet above the ground, and Ken is walking at the rate of 3.3 feet per second. Find a function, $d(t)$, which gives the distance Ken is from the streetlight in terms of time. Find a function, $S(d)$, which gives the length of Ken's shadow in terms of d . Then find $(S \circ d)(t)$.

A) $(S \circ d)(t) = 1.82t$ B) $(S \circ d)(t) = 3.14t$ C) $(S \circ d)(t) = 5.58t$ D) $(S \circ d)(t) = 2.48t$

Answer: D

419) Ken is 6 feet tall and is walking away from a streetlight. The streetlight has its light bulb 14 feet above the ground, and Ken is walking at the rate of 4.8 feet per second. Find a function, $d(t)$, which gives the distance Ken is from the streetlight in terms of time. Find a function, $S(d)$, which gives the length of Ken's shadow in terms of d . Then find $(S \circ d)(t)$. What is the meaning of $(S \circ d)(t)$?

A) $(S \circ d)(t)$ gives the distance Ken is from the streetlight in terms of time.

B) $(S \circ d)(t)$ gives the length of Ken's shadow in terms of time.

C) $(S \circ d)(t)$ gives the time in terms of Ken's distance from the streetlight.

D) $(S \circ d)(t)$ gives the length of Ken's shadow in terms of his distance from the streetlight.

Answer: B

Chapter 2 Test Form A

Name: _____

Date: _____

1. Match the set described in Column I with the correct interval notation from Column II. Choices in Column II may be used once, more than once, or not at all.

Column I

- (a) domain of $f(x) = (x - 3)^2$
- (b) range of $f(x) = (x - 3)^2$
- (c) domain of $x = y^2 + 3$
- (d) range of $x = y^2 + 3$
- (e) domain of $f(x) = 3 - 2x$
- (f) range of $f(x) = 23 - x$
- (g) domain of $f(x) = 2x + 3$
- (h) range of $f(x) = 2x - 3$
- (i) domain of $f(x) = |x - 3|$
- (j) range of $f(x) = |x| + 3$

Column II

- A. $[3, \infty)$
- B. $[0, \infty)$
- C. $(3, \infty)$
- D. $(-\infty, 0]$
- E. $[-3, \infty)$
- F. $(-\infty, 3]$
- G. $(-\infty, \infty)$
- H. $(-\infty, 0)$

2. Consider the piecewise-defined function defined by $f(x) = \begin{cases} x^2 - 6 & \text{if } x \leq 1 \\ e^{2x} & \text{if } x > 1 \end{cases}$.

- (a) Graph f by hand.
- (b) Use a graphing calculator to obtain an accurate graph in the window $[-5, 10]$ by $[-10, 10]$.

3. Graph $y = f(x)$ by hand.

- (a) $f(x) = (x - 1)^3 + 2$
- (b) $f(x) = 22x - 3$

4. If the point $(2, 7)$ lies on the graph of $y = f(x)$, determine a point on the graph of each equation.

- (a) $y = f\left(\frac{1}{x}\right)$
- (b) $y = f(4x)$

2

5. Observe the coordinates displayed at the bottom of the given screen showing a portion of the graph $y = f(x)$. Answer each of the following based on your observation.

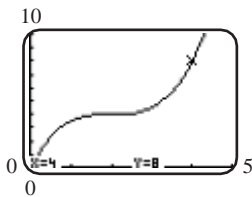

- (a) If the graph is symmetric with respect to the y -axis, what are the coordinates of another point on the graph?
- (b) If the graph is symmetric with respect to the origin, what are the coordinates of another point on the graph?
- (c) Suppose the graph is symmetric with respect to the y -axis. Sketch a typical viewing window with dimensions $[-5, 5]$ by $[0, 10]$. Then draw the graph you would expect to see in this window.

Test Form 2-A (continued)

Name: _____

6. (a) Write a description that explains how the graph of $y = 2\sqrt{x-1} + 3$ can be obtained by translating the graph of $y = \sqrt{x}$.
 (b) Sketch by hand the graph of $y = -2f(x) + 2f(x) - 3$. State the domain and the range.

7. Consider the graph of the function shown here.

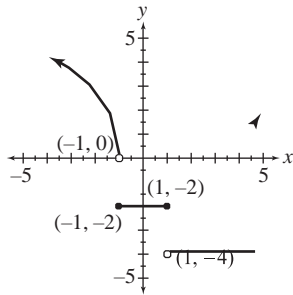

State the interval(s) over which the function is:

- (a) increasing (b) decreasing (c) constant (d) continuous
 (e) What is the domain of the function?
 (f) What is the range of this function?
8. Solve each of the following analytically, showing all steps. Next graph $y_1 = f(4x + 2)$ and $y_2 = 2$ in the standard viewing window of a graphing calculator. Then state how the graphs support your solution in each case.
 (a) $f(4x + 2) = 2$ (b) $f(4x + 2) \leq 2$ (c) $f(4x + 2) \geq 2$
9. Given $f(x) = 3x^2 - 2x - 6$ and $g(x) = 3x + 5$, find each of the following. Simplify the expression when possible.
 (a) $(f - g)(x)$ (b) $\frac{f}{g}(x)$ (c) the domain of $\frac{f}{g}$
 (d) $(f \circ g)(x)$ (e) $\frac{f(x+h) - f(x)}{h}$ ($h \neq 0$)

10. The graph of $y = f(x)$ is shown here.

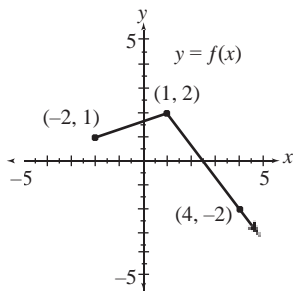

Sketch the graph of each of the following. Use ordered pairs to indicate 3 points on the graph.

- (a) $y = f(x + 3)$ (b) $y = f(x) + 3$ (c) $y = f(-x)$

$$(d) y = -f(x)$$

$$(e) y = 3f(x)$$

$$(f) y = |f(x)|$$

Test Form 2-A (continued)

Name: _____

Date: _____

11. The price of postage for mail is defined by the function $P(x) = 0.46x + 1$, where x represents the weight of the letter in ounces.
- (a) Using dot mode and the window $[0, 5]$ by $[0, 4]$, graph this function on a graphing calculator.
 - (b) Use the graph to find the price of a 2.42 ounce envelope.
12. The members of the New Jazz band want to record a new CD. The cost to record a CD is \$1700 for studio fees plus \$2.25 for each CD produced.
- (a) Write a cost function C , where x represents the number of CD's produced.
 - (b) Find the revenue function R , if each CD in part (a) sells for \$10.
 - (c) Write the profit function.
 - (d) How many CD's must be produced and sold before the band earns a profit?
 - (e) Support the results of part (d) graphically.

Chapter 2 Test Form B

Name: _____

1. Match the set described in Column I with the correct interval notation from Column II. Choices in Column II may be used once, more than once, or not at all.

Column I

- (a) domain of $f(x) = x^2 - 5$
- (b) range of $f(x) = x^2 - 5$
- (c) domain of $f(x) = \sqrt{2x + 5}$
- (d) range of $f(x) = \sqrt{2x - 5}$
- (e) domain of $f(x) = \lfloor x \rfloor - 5$
- (f) range of $f(x) = \lfloor x + 5 \rfloor$
- (g) domain of $f(x) = \sqrt{2x - 5}$
- (h) range of $f(x) = \sqrt{2x + 5}$
- (i) domain of $x = y^2 - 5$
- (j) range of $x = y^2 - 5$

Column II

- A. $(-q, q)$
- B. $[0, q)$
- C. $(-q, 0]$
- D. $[-5, q)$
- E. $(5, q)$
- F. $(-5, q)$
- G. $(-q, 5]$
- H. $[5, q)$

2. Consider the piecewise-defined function defined by $f(x) = \begin{cases} x^2 - 7 & \text{if } x < 1 \\ e^{-2x} + 5 & \text{if } x \geq 1 \end{cases}$.
- (a) Graph f by hand.
 - (b) Use a graphing calculator to obtain an accurate graph in the window $[-5, 10]$ by $[-10, 10]$.

3. Graph $y = f(x)$ by hand.

(a) $f(x) = |x + 2| - 1$ (b) $f(x) = \sqrt{-x}$

4. If the point $(4, 2)$ lies on the graph of $y = f(x)$, determine a point on the graph of each equation.

(a) $y = f(x - 3)$ (b) $y = f(x) - 3$

5. Observe the coordinates displayed at the bottom of the given screen showing a portion of the graph $y = f(x)$. Answer each of the following based on your observation.

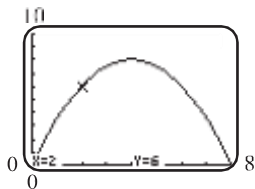

- (a) If the graph is symmetric with respect to the y -axis, what are the coordinates of another point on the graph?
 - (b) If the graph is symmetric with respect to the origin, what are the coordinates of another point on the graph?
 - (c) Suppose the graph is symmetric with respect to the y -axis. Sketch a typical viewing window with dimensions $[-8, 8]$ by $[0, 10]$. Then draw the graph you would expect to see in this window.
6. (a) Write a description that explains how the graph of $y = \sqrt{2x + 5}$ can be obtained by translating the graph of $y = \sqrt{2x}$.
- (b) Sketch by hand the graph of $y = -\lfloor x - 2 \rfloor + 3$. State the domain and the range.

Name: _____

Date: _____

Test Form 2-B (continued)

7. Consider the graph of the function shown here.

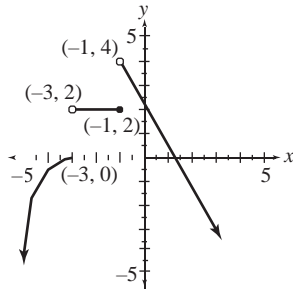

State the interval(s) over which the function is:

- (a) increasing (b) decreasing (c) constant (d) continuous
- (e) What is the domain of the function?
- (f) What is the range of this function?
8. Solve each of the following analytically, showing all steps. Next graph $y_1 = f(2x - 1)$ and $y_2 = 5$ in the standard viewing window of a graphing calculator. Then state how the graphs support your solution in each case.
- (a) $f(2x - 1) = 5$ (b) $f(2x - 1) \leq 5$ (c) $f(2x - 1) \geq 5$
9. Given $f(x) = 2x^2 + 5x - 3$ and $g(x) = 2x + 1$, find each of the following. Simplify the expression when possible.
- (a) $(f - g)(x)$ (b) $\frac{f}{g}(x)$ (c) the domain of $\frac{f}{g}$
- (d) $(f \circ g)(x)$ (e) $\frac{f(x + h) - f(x)}{h}$ ($h \neq 0$)

10. The graph of $y = f(x)$ is shown here.

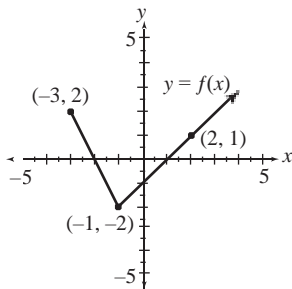

Sketch the graph of each of the following. Use ordered pairs to indicate 3 points on the graph.

- (a) $y = f(x) - 3$ (b) $y = f(x - 3)$ (c) $y = -f(x)$
- (d) $y = f(-x)$ (e) $y = 3f(x)$ (f) $y = f(f(x))$

Test Form 2-B (continued)

Name: _____

11. In The Branches Tree Service has been hired to clear an area of trees. If x represents the number of hours they will work, where $x \geq 0$, then the function $C(x) = 225x + 375$ gives the total cost in dollars.
- (a) Using dot mode and the window $[0, 10]$ by $[0, 3000]$, graph this function on a graphing calculator.
 - (b) Use the graph to find the price of an 8 hour day.
12. Mark and Scott open a new doughnut shop. Their initial cost is \$12,000. A dozen doughnuts costs \$0.25 to make.
- (a) Write a cost function C , where x represents the number of dozens of doughnuts made.
 - (b) Find the revenue function R , if each dozen in part (a) sells for \$8.00.
 - (c) Write the profit function.
 - (d) How many dozen doughnuts must be produced and sold before the men earn a profit?
 - (e) Support the results of part (d) graphically.

Chapter 2 Test Form C

Name: _____

Date: _____

1. Match the set described in Column I with the correct interval notation from Column II. Choices in Column II may be used once, more than once, or not at all.

Column I

- (a) domain of $f(x) = \sqrt{2x - 2}$
- (b) range of $f(x) = \sqrt{2x + 2}$
- (c) domain of $f(x) = \sqrt{x - 2}$
- (d) range of $f(x) = \sqrt{x} + 2$
- (e) domain of $f(x) = x^2 + 2$
- (f) range of $f(x) = x^2 + 2$
- (g) domain of $f(x) = \sqrt{2x + 2}$
- (h) range of $f(x) = \sqrt{2x - 2}$
- (i) domain of $x = y^2 + 2$
- (j) range of $x = y^2 + 2$

Column II

- A. $(-q, 0)$
- B. $(-q, q)$
- C. $(-q, 2]$
- D. $[-2, q)$
- E. $(-q, 0]$
- F. $(2, q)$
- G. $[0, q)$
- H. $[2, q)$

2. Consider the piecewise-defined function defined by $f(x) = \begin{cases} 4\sqrt{-x} + 2 & \text{if } x \leq -4 \\ .5x^2 - 6 & \text{if } x > -4 \end{cases}$.

- (a) Graph f by hand.
- (b) Use a graphing calculator to obtain an accurate graph in the window $[-15, 10]$ by $[-10, 20]$.

3. Graph $y = f(x)$ by hand.

(a) $f(x) = -(x + 1)^2 + 2$

(b) $f(x) = (x - 3)^2 - 3$

4. If the point $(-1, -2)$ lies on the graph of $y = f(x)$, determine a point on the graph of each equation.

(a) $y = -f(x)$

(b) $y = f(-x)$

5. Observe the coordinates displayed at the bottom of the given screen showing a portion of the graph $y = f(x)$. Answer each of the following based on your observation.

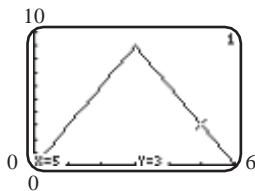

- (a) If the graph is symmetric with respect to the y -axis, what are the coordinates of another point on the graph?
- (b) If the graph is symmetric with respect to the origin, what are the coordinates of another point on the graph?
- (c) Suppose the graph is symmetric with respect to the y -axis. Sketch a typical viewing window with dimensions $[-6, 6]$ by $[0, 10]$. Then draw the graph you would expect to see in this window.

Test Form 2-C (continued)

Name: _____

Date: _____

6. (a) Write a description that explains how the graph of $f(x) = \frac{1}{2}x + 3$ can be obtained by translating the graph of $y = 2x$.
- (b) Sketch by hand the graph of $y = -3f(x) - 6$. State the domain and the range.
7. Consider the graph of the function shown here.

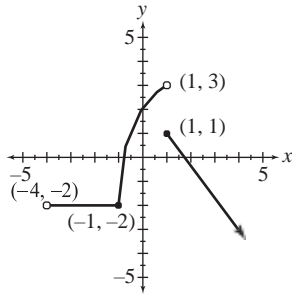

State the interval(s) over which the function is:

- (a) increasing (b) decreasing (c) constant (d) continuous
- (e) What is the domain of the function?
- (f) What is the range of this function?
8. Solve each of the following analytically, showing all steps. Next graph $y_1 = f(3x - 6)$ and $y_2 = 3$ in the standard viewing window of a graphing calculator. Then state how the graphs support your solution in each case.
- (a) $f(3x - 6) = 3$ (b) $f(3x - 6) \leq 3$ (c) $f(3x - 6) \geq 3$
9. Given $f(x) = 4x^2 - 3x + 2$ and $g(x) = 3x + 2$, find each of the following. Simplify the expression when possible.

- (a) $(f - g)(x)$ (b) $\frac{f}{g}(x)$ (c) the domain of $\frac{f}{g}$
- (d) $(f \circ g)(x)$ (e) $\frac{f(x+h) - f(x)}{h}$ ($h \neq 0$)

10. The graph of $y = f(x)$ is shown here.

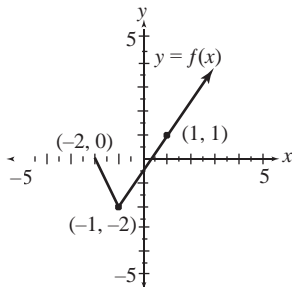

Sketch the graph of each of the following. Use ordered pairs to indicate 3 points on the graph.

- (a) $y = f(x + 2)$ (b) $y = f(x) + 2$ (c) $y = f(-x)$

$$(d) y = -f(x)$$

$$(e) y = 2f(x)$$

$$(f) y = |f(x)|$$

Name: _____

Date: _____

Test Form 2-C (continued)

11. The PayMore car rental company is a luxury car rental agency. If x represents the number of days you rent the car, where $x \geq 0$, then the function $C(x) = 300x + 500$ gives the total cost in dollars.
- (a) Using dot mode and the window $[0, 10]$ by $[0, 3700]$, graph this function on a graphing calculator.
 - (b) Use the graph to find the price of a 3.25 day rental.
12. The class of 2014 wants to raise money for a class trip by selling mini-doughnuts. Their initial cost is \$500 to rent the equipment. A bag of doughnuts costs \$0.35 to make.
- (a) Write a cost function C , where x represents the number of bags of doughnuts made.
 - (b) Find the revenue function R , if each bag in part (a) sells for \$3.50.
 - (c) Write the profit function.
 - (d) How many bags of doughnuts must be produced and sold before the class earns a profit?
 - (e) Support the results of part (d) graphically.

Chapter 2 Test Form D

Name: _____

1. Match the set described in Column I with the correct interval notation from Column II. Choices in Column II may be used once, more than once, or not at all.

Column I

- (a) domain of $f(x) = x^2 + 9$
- (b) range of $f(x) = x^2 + 9$
- (c) domain of $f(x) = \sqrt{x - 9}$
- (d) range of $f(x) = \sqrt{x + 9}$
- (e) domain of $f(x) = \sqrt{x - 9}$
- (f) range of $f(x) = \sqrt{x + 9}$
- (g) domain of $f(x) = \sqrt{x + 9}$
- (h) range of $f(x) = \sqrt{x - 9}$
- (i) domain of $x = y^2 + 9$
- (j) range of $x = y^2 + 9$

Column II

- A. $[0, 9]$
- B. $[9, 9]$
- C. $(-9, 9]$
- D. $(-9, 9)$
- E. $(-9, 9)$
- F. $(9, 9]$
- G. $(-9, 0]$
- H. $[-9, 9]$

2. Consider the piecewise-defined function defined by $f(x) = \begin{cases} x^2 - 8 & \text{if } x \leq 4 \\ e^{-2x} - 4 & \text{if } x > 4 \end{cases}$.
- (a) Graph f by hand.
 - (b) Use a graphing calculator to obtain an accurate graph in the window $[-5, 15]$ by $[-10, 5]$.
3. Graph $y = f(x)$ by hand.
- (a) $f(x) = \sqrt{x + 1}$
 - (b) $f(x) = \sqrt{-2x}$
4. If the point $(4, 3)$ lies on the graph of $y = f(x)$, determine a point on the graph of each equation.
- (a) $y = 2f(x)$
 - (b) $y = f(2x) - 1$
5. Observe the coordinates displayed at the bottom of the given screen showing a portion of the graph $y = f(x)$. Answer each of the following based on your observation.

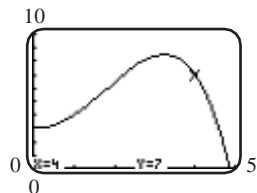

- (a) If the graph is symmetric with respect to the y -axis, what are the coordinates of another point on the graph?
 - (b) If the graph is symmetric with respect to the origin, what are the coordinates of another point on the graph?
 - (c) Suppose the graph is symmetric with respect to the y -axis. Sketch a typical viewing window with dimensions $[-5, 5]$ by $[0, 10]$. Then draw the graph you would expect to see in this window.
6. (a) Write a description that explains how the graph of $y = \sqrt{x - 4} + 5$ can be obtained by translating the graph of $y = \sqrt{x}$.
- (b) Sketch by hand the graph of $y = \frac{1}{2}\sqrt{x - 4} + 3$. State the domain and the range.

Name: _____

Date: _____

Test Form 2-D (continued)

7. Consider the graph of the function shown here.

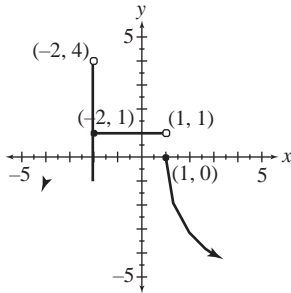

State the interval(s) over which the function is:

- (a) increasing (b) decreasing (c) constant (d) continuous
- (e) What is the domain of the function?
- (f) What is the range of this function?
8. Solve each of the following analytically, showing all steps. Next graph $y_1 = f(2x + 3)$ and $y_2 = 3$ in the standard viewing window of a graphing calculator. Then state how the graphs support your solution in each case.
- (a) $f(2x + 3) = 3$ (b) $f(2x + 3) \leq 3$ (c) $f(2x + 3) \geq 3$
9. Given $f(x) = -2x^2 + 2x - 1$ and $g(x) = 2x - 3$, find each of the following. Simplify the expression when possible.

- (a) $(f - g)(x)$ (b) $\frac{f}{g}(x)$ (c) the domain of $\frac{f}{g}$
- (d) $(f \circ g)(x)$ (e) $\frac{f(x+h) - f(x)}{h}$ (h $\neq 0$)

10. The graph of $y = f(x)$ is shown here.

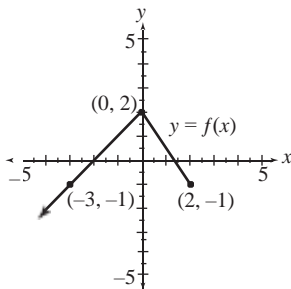

Sketch the graph of each of the following. Use ordered pairs to indicate 3 points on the graph.

- (a) $y = f(x - 2)$ (b) $y = f(x) - 2$ (c) $y = -f(x)$
- (d) $y = f(-x)$ (e) $y = 2f(x)$ (f) $y = f(f(x))$

Test Form 2-D (continued)

Name: _____

11. The Budget Printing company produces wedding invitations. If x represents the number of invitations, where $x \geq 0$, then the function $C(x) = 60\left\lfloor \frac{x}{35} \right\rfloor + 70$ gives the total cost in dollars.
- (a) Using dot mode and the window $[0, 250]$ by $[0, 500]$, graph this function on a graphing calculator.
 - (b) Use the graph to find the total cost of 150 invitations.
12. The class of 2014 wants to raise money for a class trip by printing and selling silk screen t-shirts. Their initial cost is \$150 to rent the silk screen machine. Each t-shirt costs \$3.50 to make.
- (a) Write a cost function C , where x represents the number of t-shirts produced.
 - (b) Find the revenue function R , if each t-shirt in part (a) sells for \$15.00.
 - (c) Write the profit function.
 - (d) How many t-shirts must be produced and sold before the class earns a profit?
 - (e) Support the results of part (d) graphically.