

Test Bank for Intermediate Algebra 12th edition by Bittinger Beecher and Johnson 0321924711 9780321924711

Full link download

Solution Manual

<https://testbankpack.com/p/solution-manual-for-intermediate-algebra-12th-edition-by-bittinger-beecher-and-johnson-0321924711-9780321924711/>

Test Bank

<https://testbankpack.com/p/test-bank-for-intermediate-algebra-12th-edition-by-bittinger-beecher-and-johnson-0321924711-9780321924711/>

SHORT ANSWER. Write the word or phrase that best completes each statement or answers the question.

Plot the ordered pairs on the rectangular coordinate system provided.

1) $A(2, 6)$, $B(-4, 4)$

1) _____

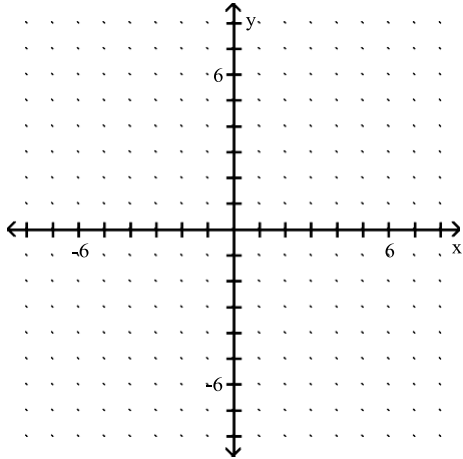

2) $A(4, -3)$, $B(-5, 3)$

2) _____

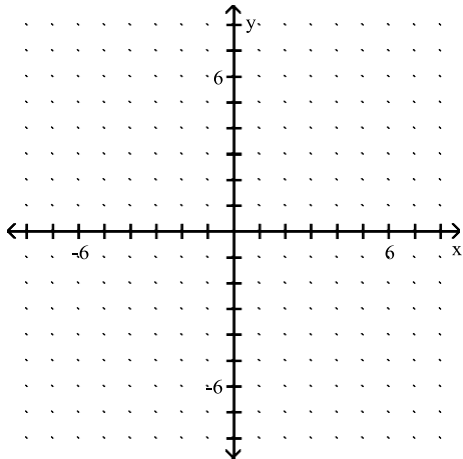

3) $A(-2, -5)$, $B(-6, 4)$

3) _____

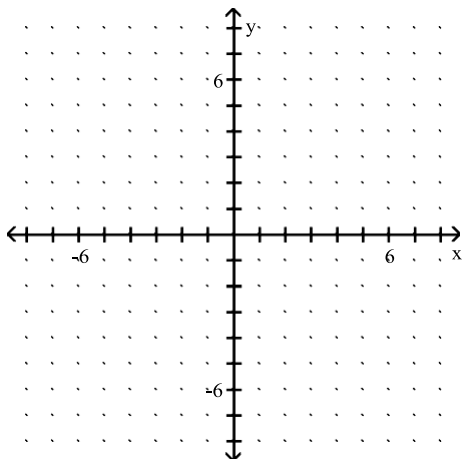

4) $A(1, 2), B(4, -2)$

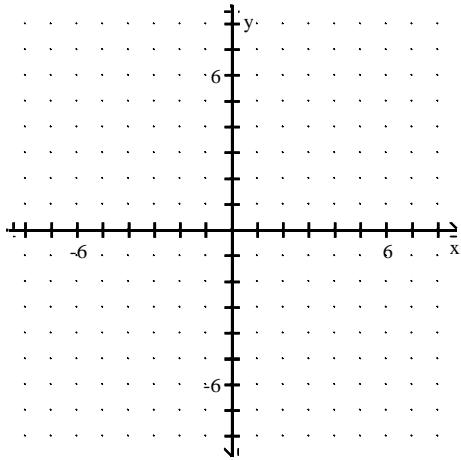

4) _____

5) $A(1, 1), B(-4, -2)$

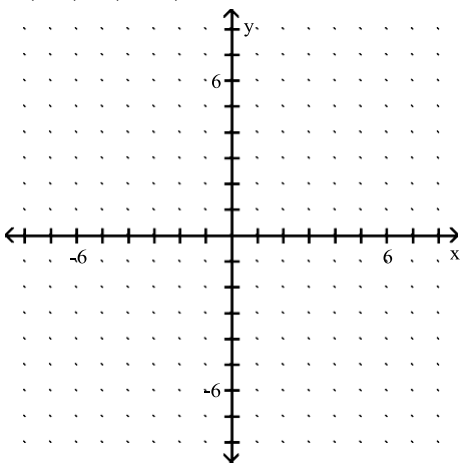

5) _____

6) $A\left(-\frac{3}{5}, -2\right), B(-1, 4)$

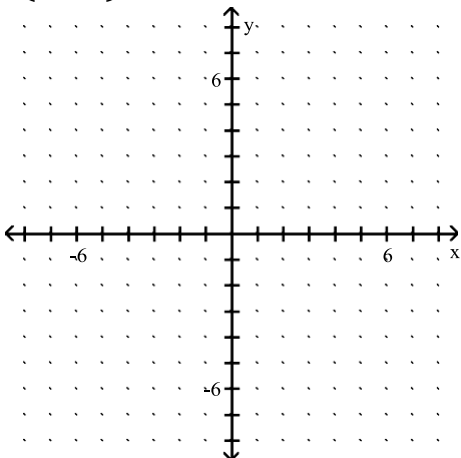

6) _____

7) A(0, 2), B (0, -1)

7) _____

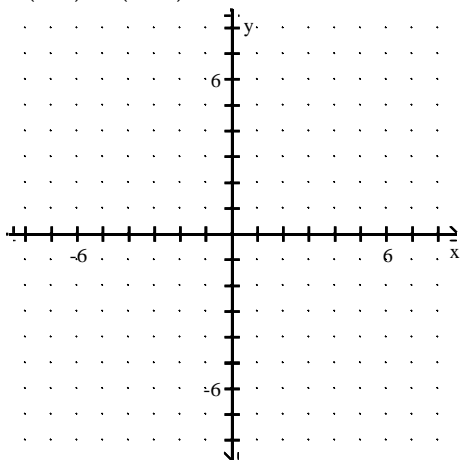

8) A(-2, 0), B (5, 0)

8) _____

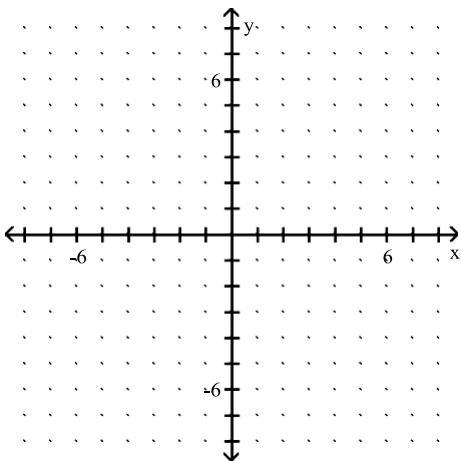

MULTIPLE CHOICE. Choose the one alternative that best completes the statement or answers the question.

Determine whether the given point is a solution of the equation.

9) $x + y = 14$; (6, 8)

9) _____

A) No

B) Yes

10) $x + y = 14$; (7, 8)

10) _____

A) No

B) Yes

11) $x - y = 64$; (8, 6)

11) _____

A) No

B) Yes

12) $2x + y = 15$; (5, 5)

12) _____

A) Yes

B) No

13) $2x + 3y = 16$; (2, 4)

A)
No

7) A(0, 2), B (0, -1)

14) $3x - 4y = 32$; (4, 5)

A) No

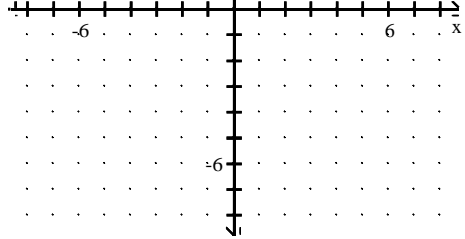

B) Yes

B) Yes

7) _____

13) _____

14) _____

15) $-7x + 18y = 58$; (2, 4)

A) Yes

B) No

15) _____

16) $y = 3x$; (2, 6)

A) Yes

B) No

16) _____

SHORT ANSWER. Write the word or phrase that best completes each statement or answers the question.

Show that the two ordered pairs are solutions to the given equation. Then use the graph of the two points to determine another solution. Answers may vary.

17) $y = x - 3$; (7, 4), (2, -1)

17) _____

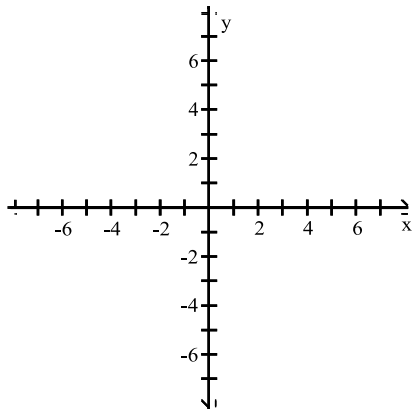

18) $y = x + 3$; (1, 4), (-3, 0)

18) _____

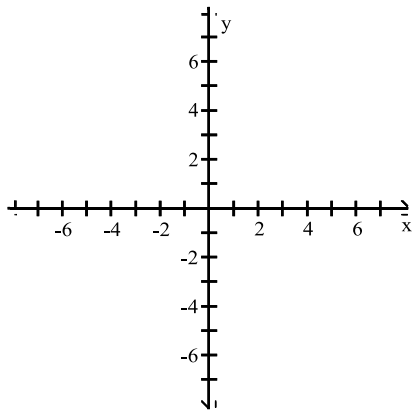

19) $y = -\frac{1}{2}x + 5$; (2, 6), (-4, 3)

19) _____

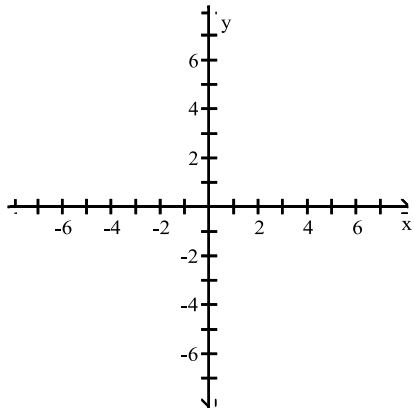

20) $y = \frac{1}{2}x - 1$; (6, 2), (0, -1)

20) _____

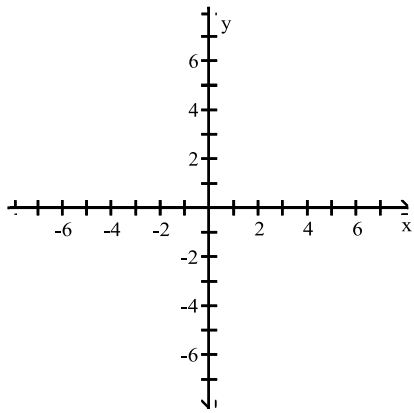

21) $2x + y = 6$; (3, 0), (6, -6)

21) _____

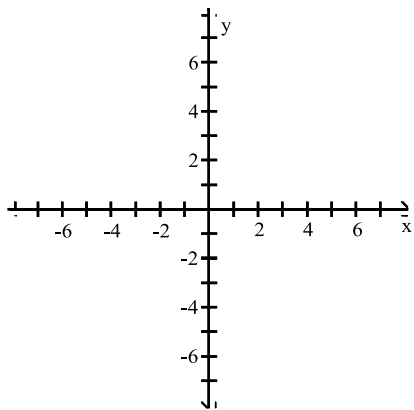

22) $x + 2y = 8$; (6, 1), (-2, 5)

22) _____

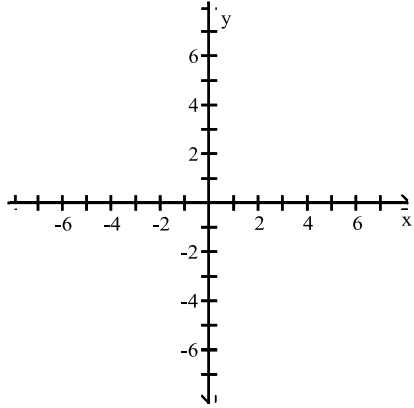

23) $6x - 2y = 6$; (0, -3), (2, 3)

23) _____

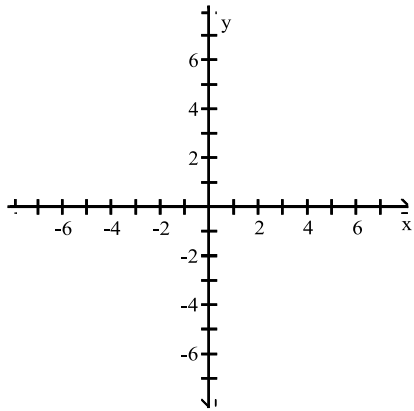

24) $3x - 3y = 12$; (-1, -5), (2, -2)

24) _____

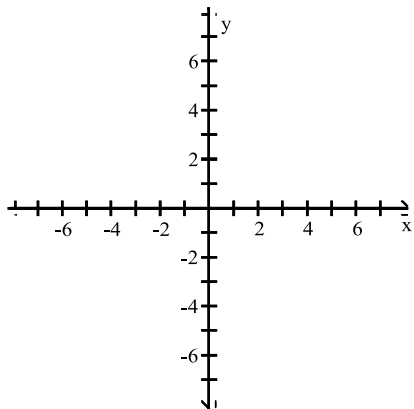

MULTIPLE CHOICE. Choose the one alternative that best completes the statement or answers the question.

Graph the linear equation.

25) $y = 3x + 4$

25) _____

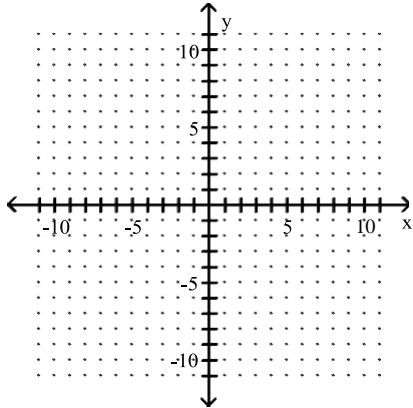

A)

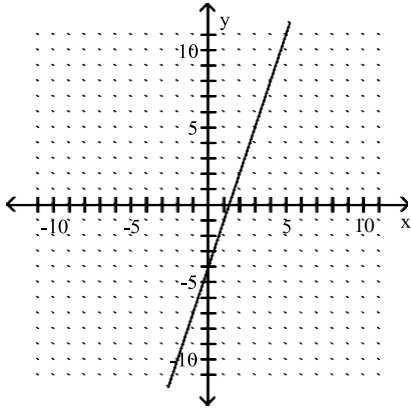

B)

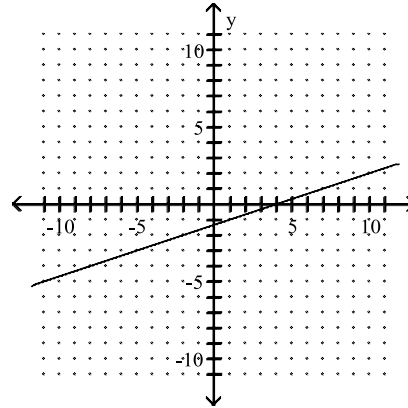

C)

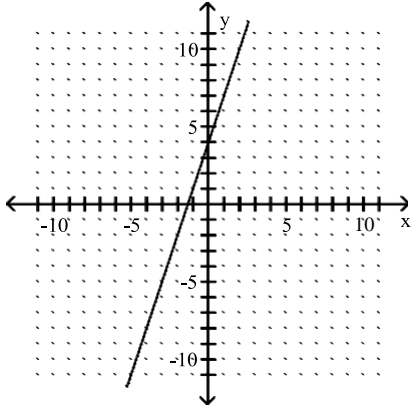

D)

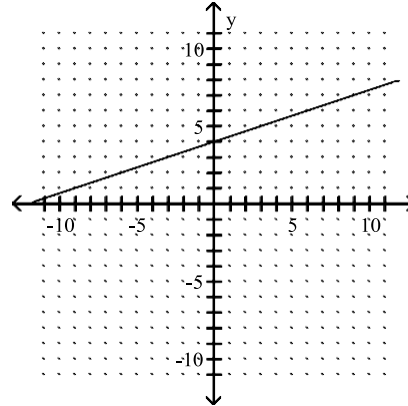

26) $y = \frac{5}{2}x - 2$

26) _____

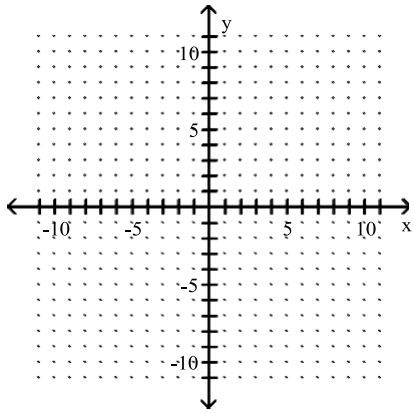

A)

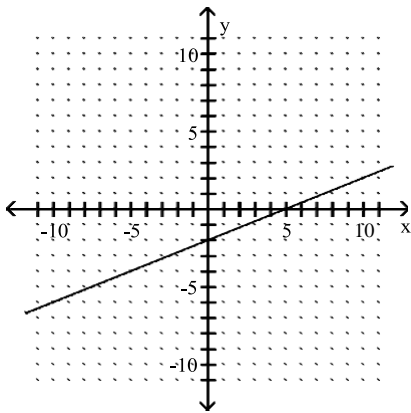

C)

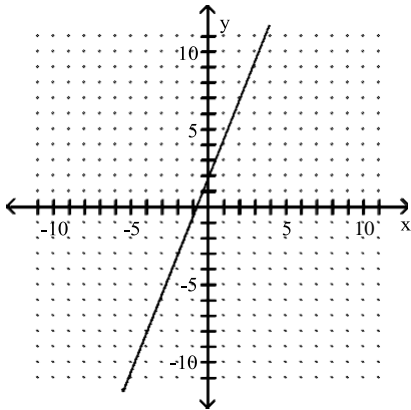

B)

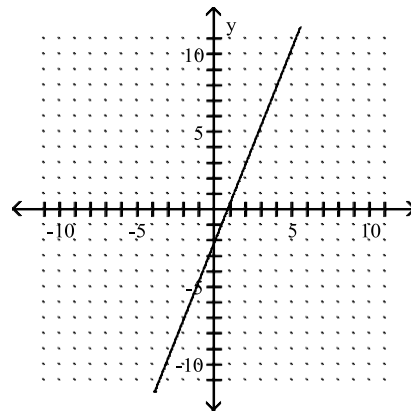

D)

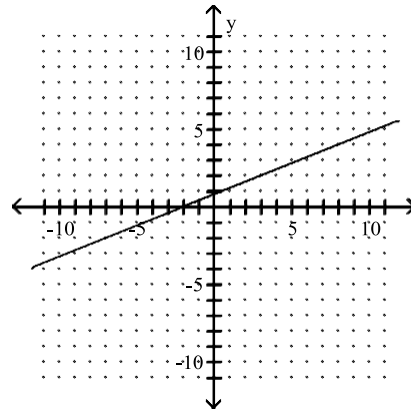

$$27) y = \frac{1}{3}x + \frac{4}{3}$$

27) _____

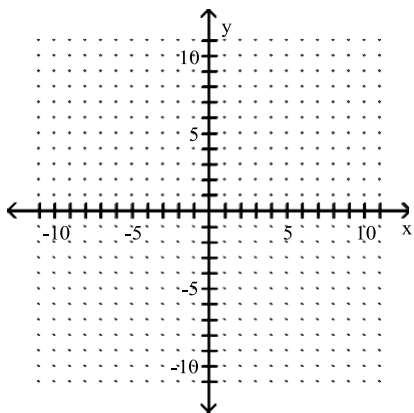

A)

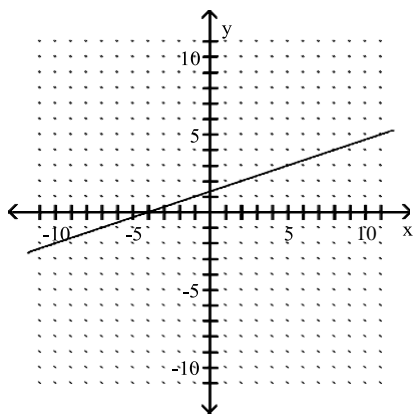

C)

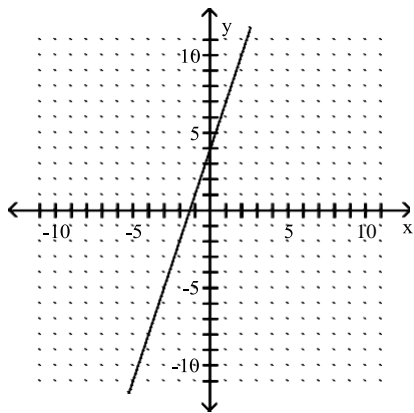

B)

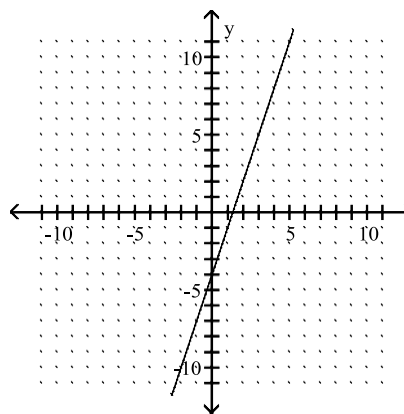

D)

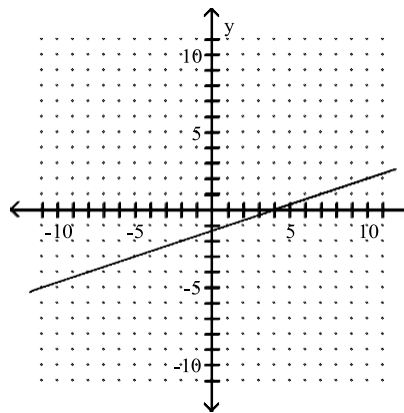

28) $x + 7y = -2$

28) _____

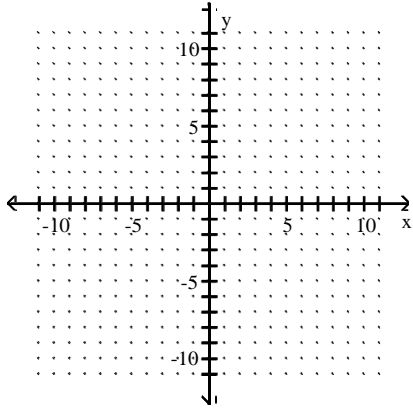

A)

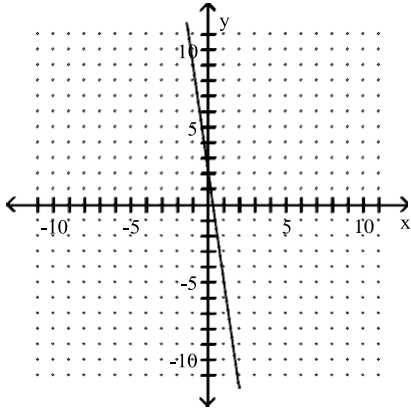

C)

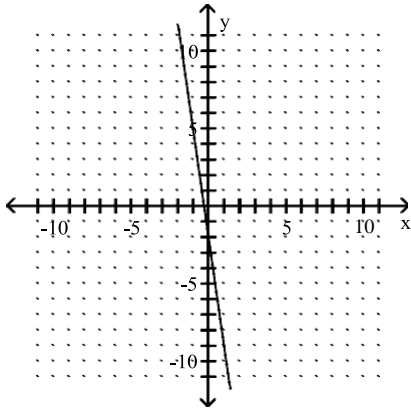

B)

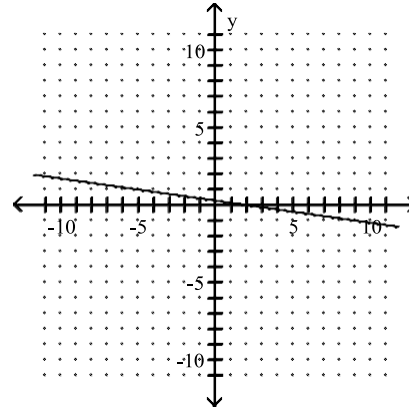

D)

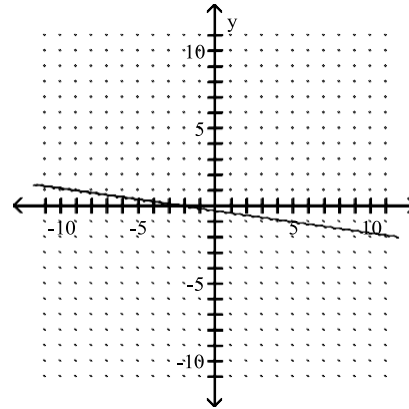

29) $2y - 16x = -2$

29) _____

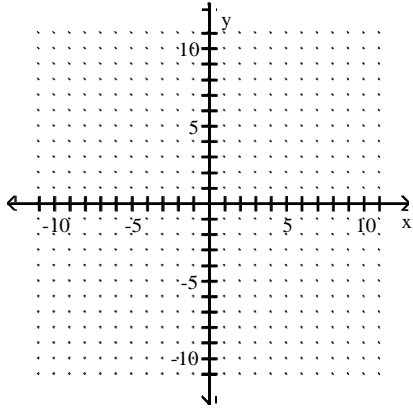

A)

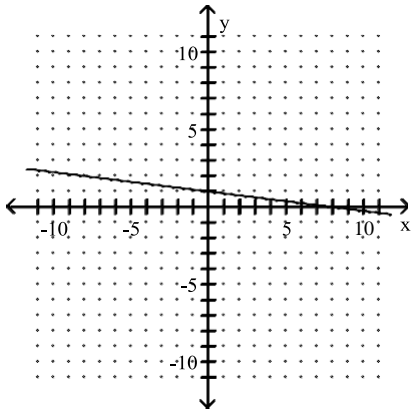

C)

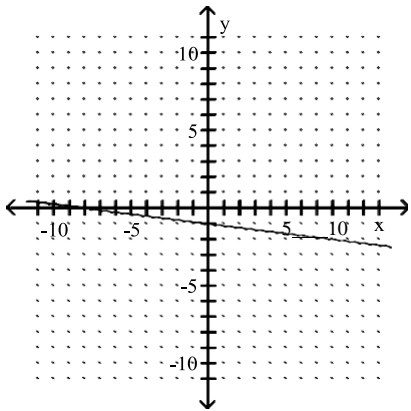

B)

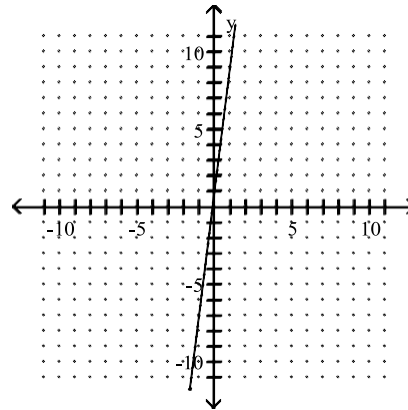

D)

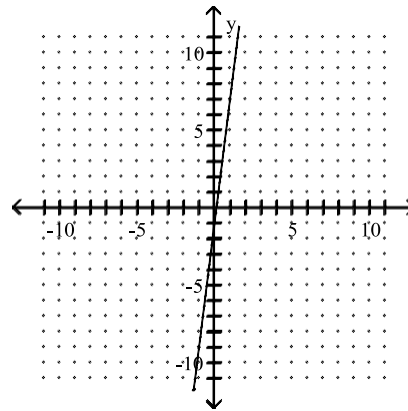

30) $-9x - y = 4$

30) _____

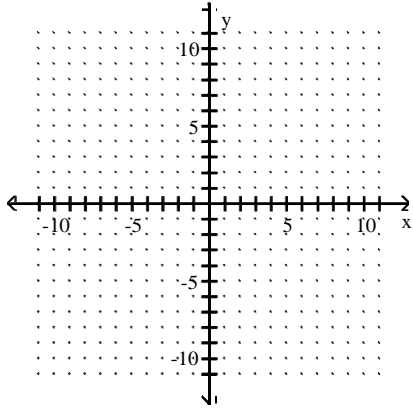

A)

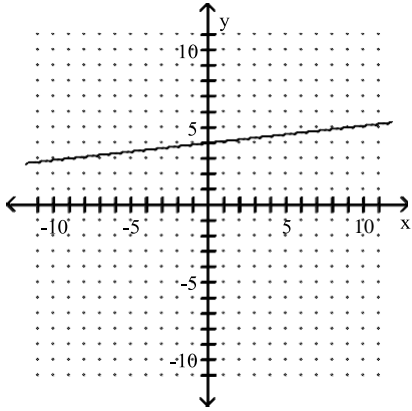

C)

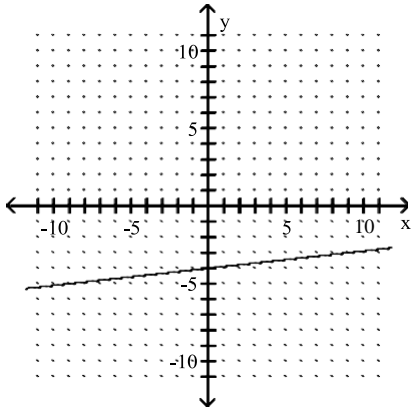

B)

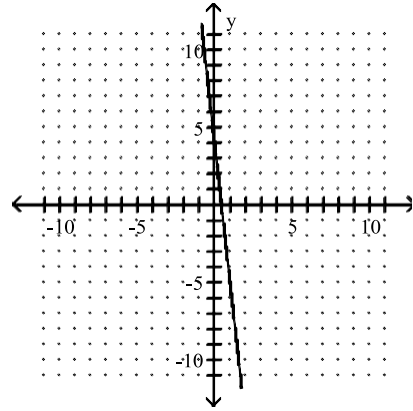

D)

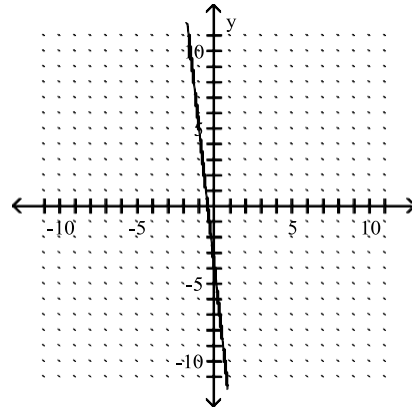

31) $y = \frac{1}{9}x + \frac{4}{9}$

31) _____

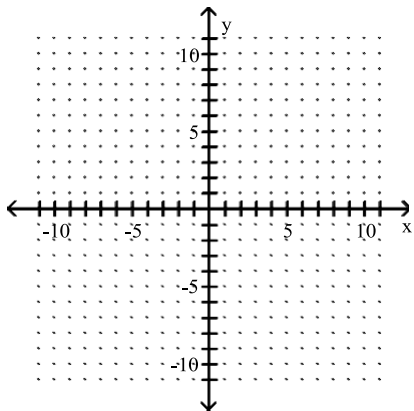

A)

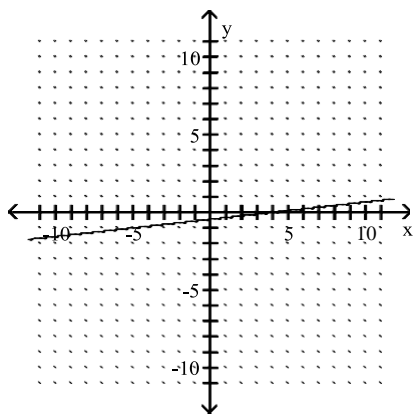

C)

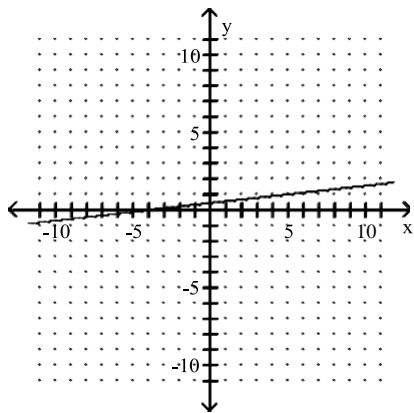

B)

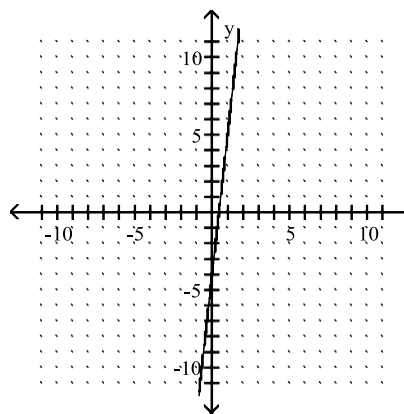

D)

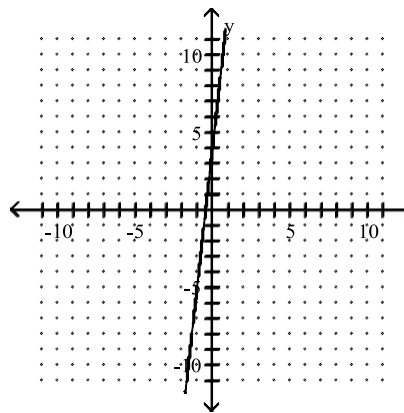

32) $-4x - 36y = 12$

32) _____

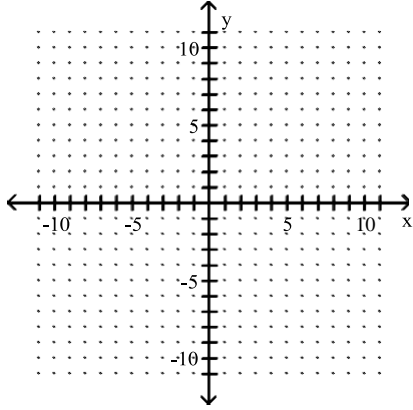

A)

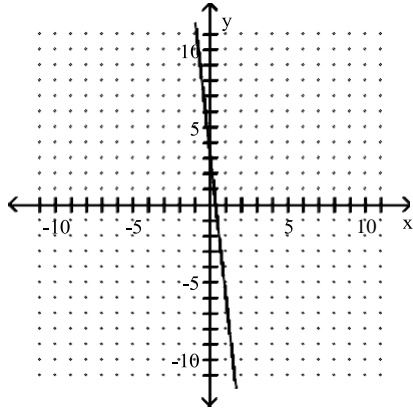

C)

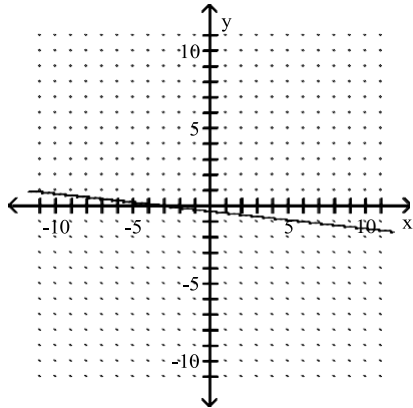

B)

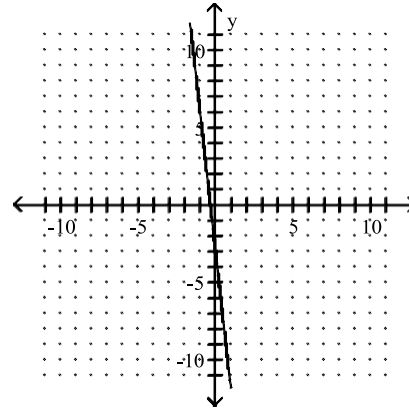

D)

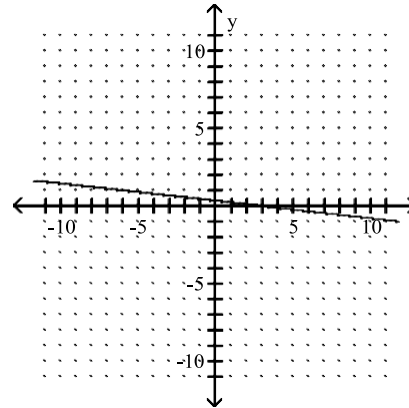

33) $-9x - y = 0$

33) _____

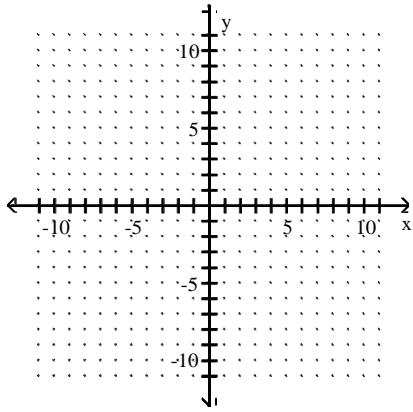

A)

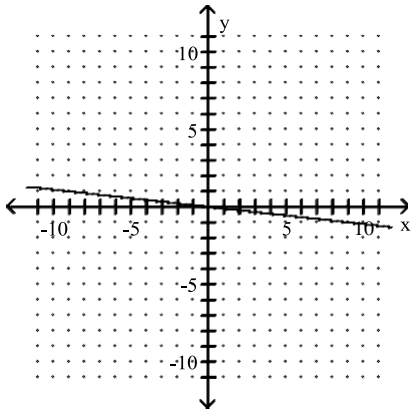

B)

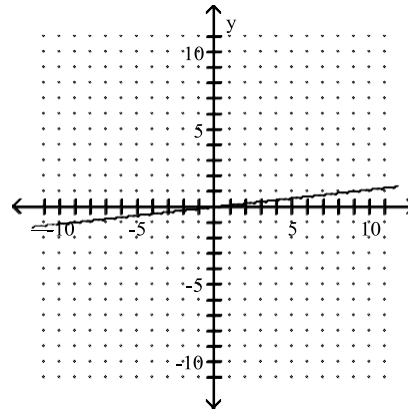

C)

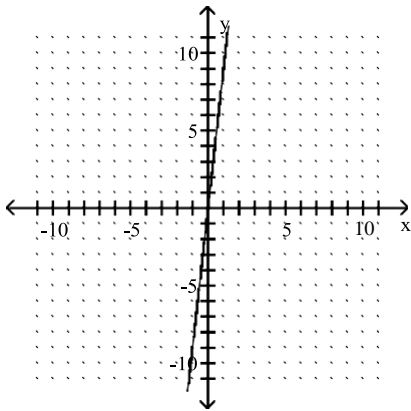

D)

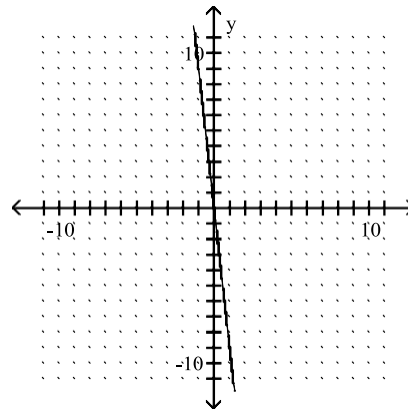

34) $-6x + y = 0$

34) _____

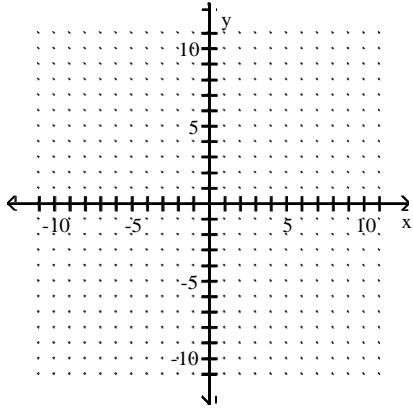

A)

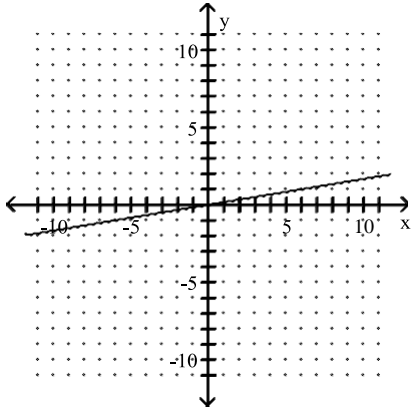

B)

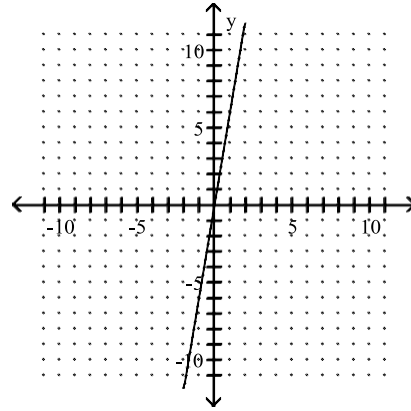

C)

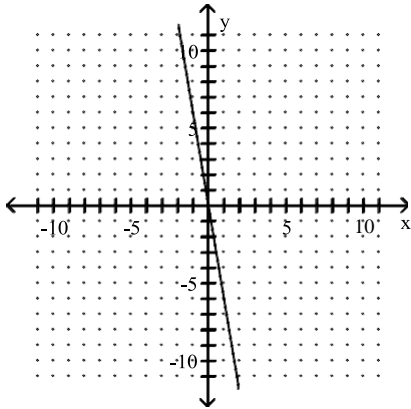

D)

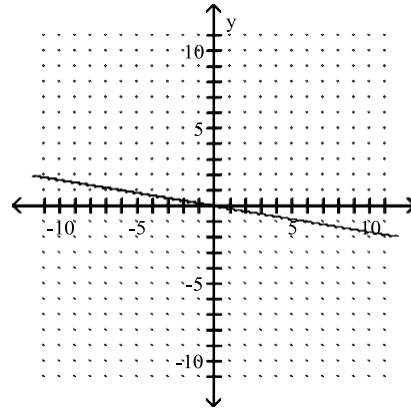

Graph.

35) $y = -4x^2$

35) _____

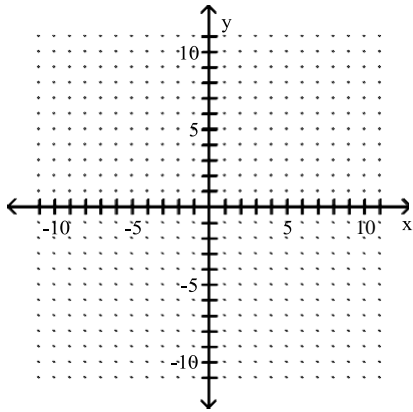

A)

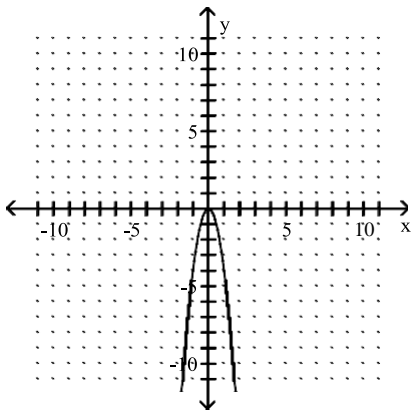

B)

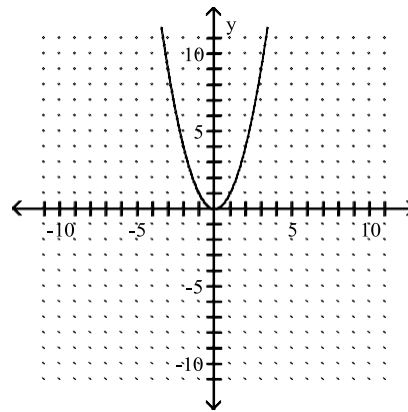

C)

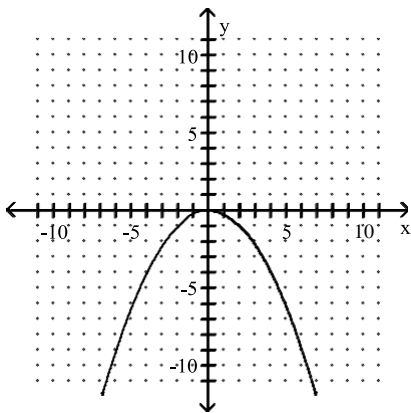

D)

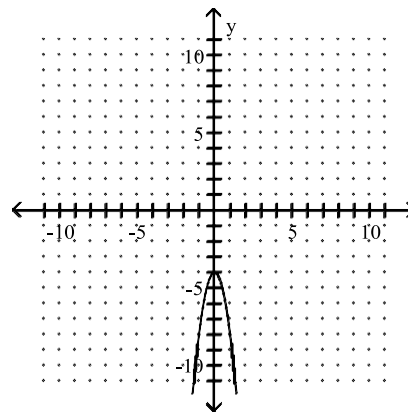

36) $y = x^2 + 5$

36) _____

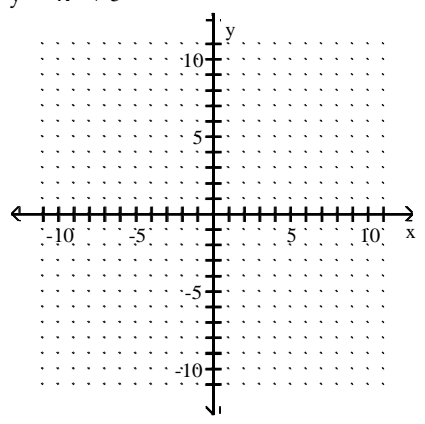

A)

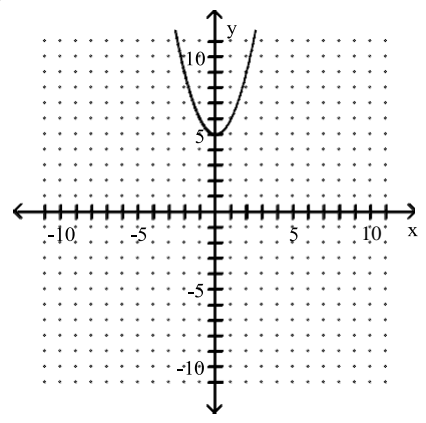

B)

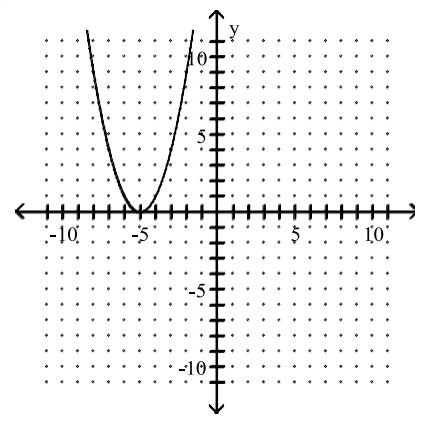

C)

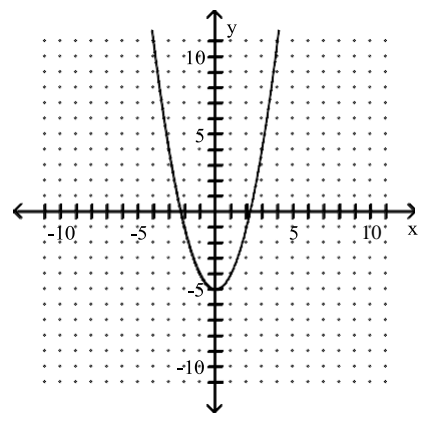

D)

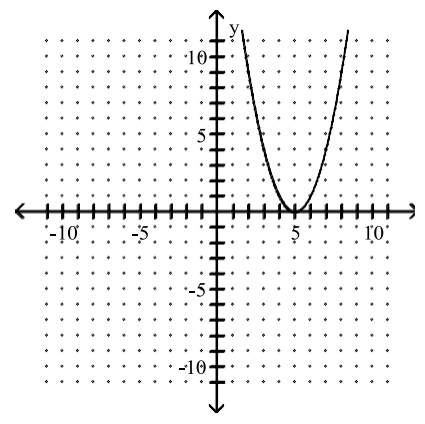

37) $y = -x^2 + 1$

37) _____

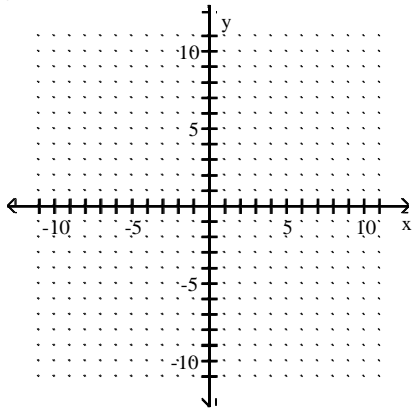

A)

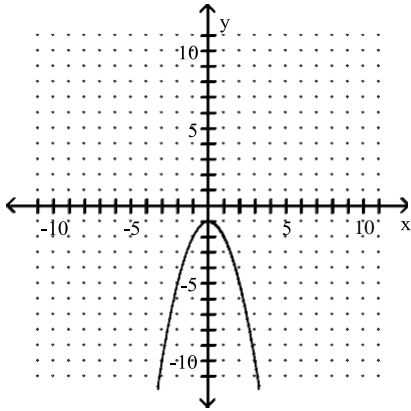

B)

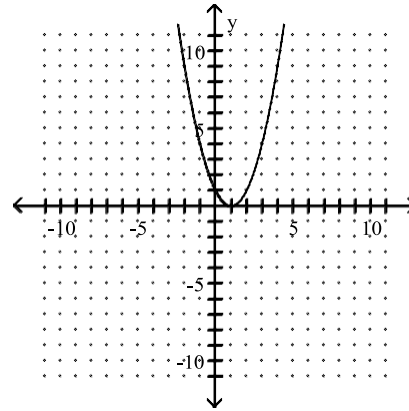

C)

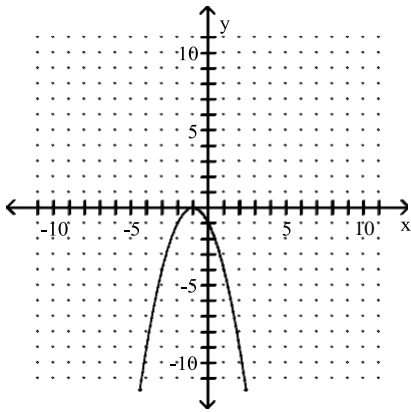

D)

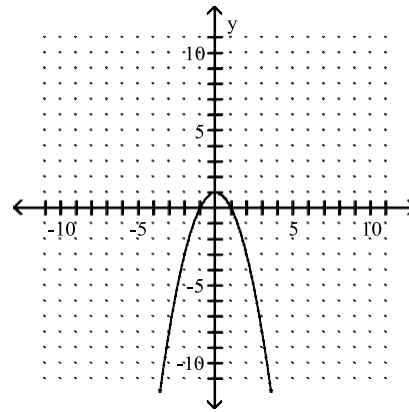

38) $y = 5x^2 - 1$

38) _____

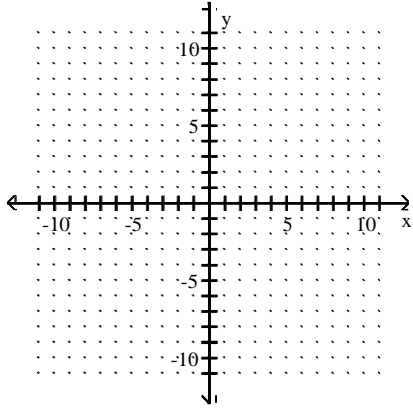

A)

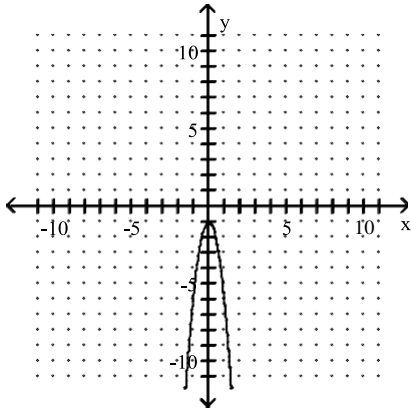

B)

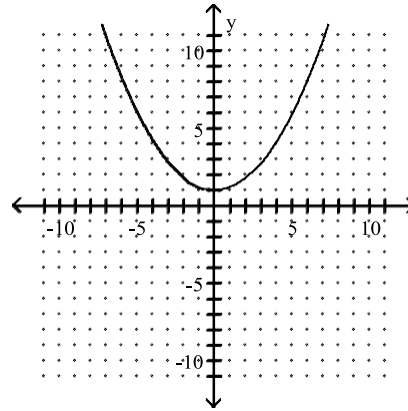

C)

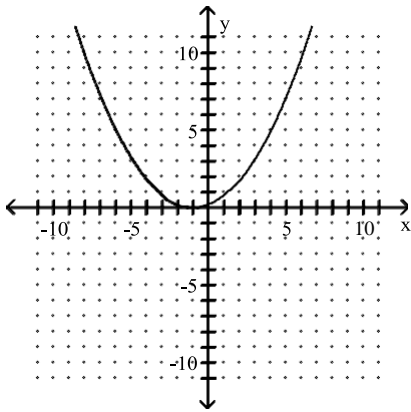

D)

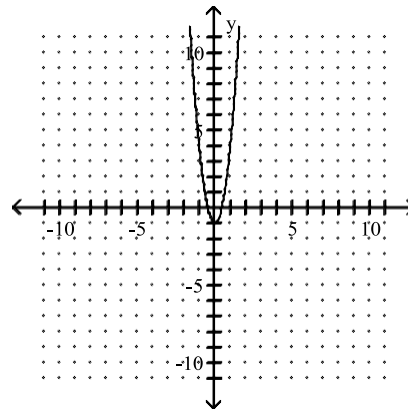

39) $y = \frac{3}{x}$

39) _____

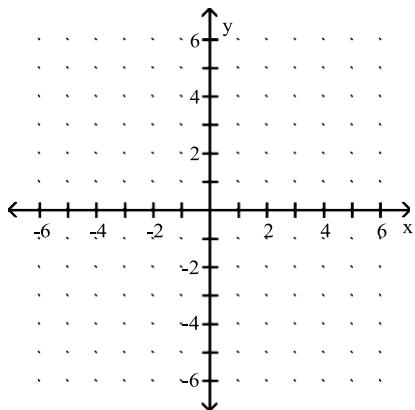

A)

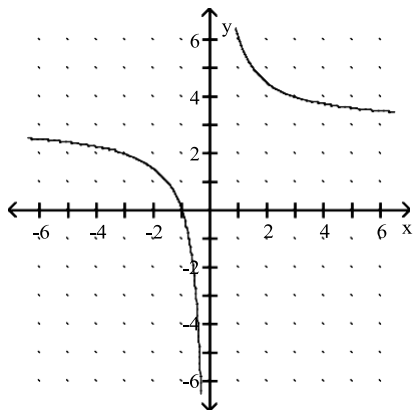

B)

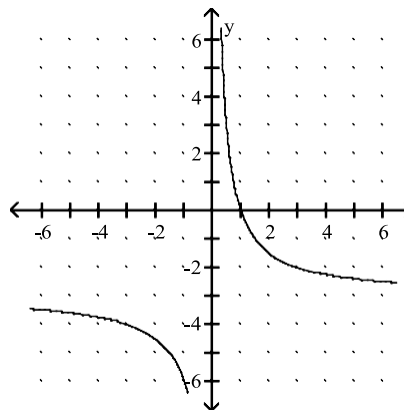

C)

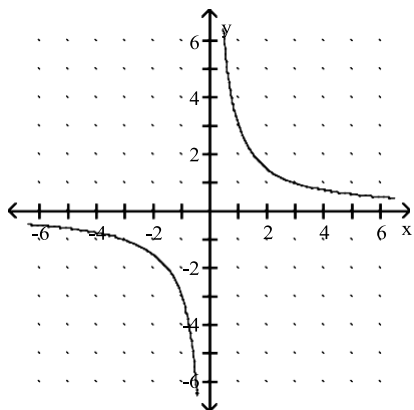

D)

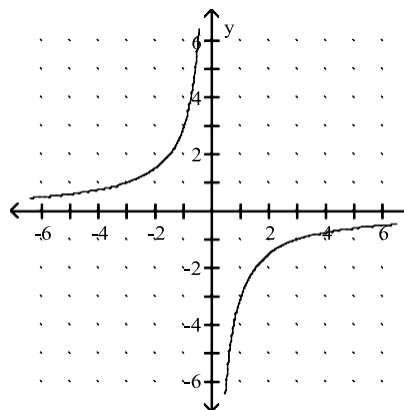

40) $y = -\frac{1}{x}$

40) _____

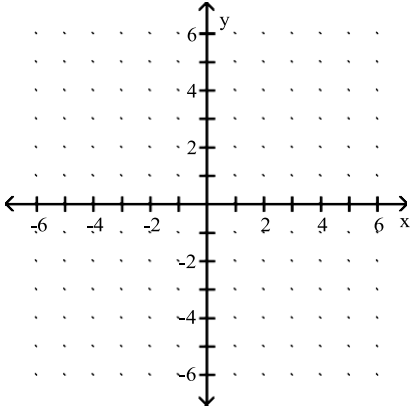

A)

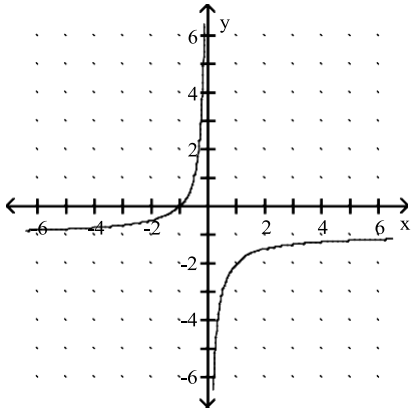

B)

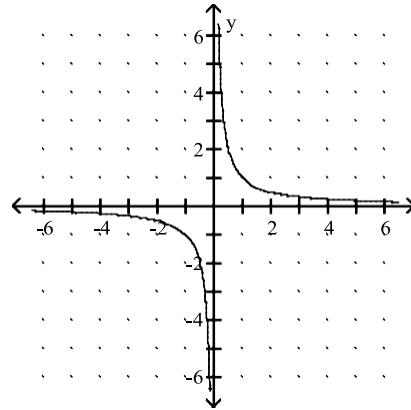

C)

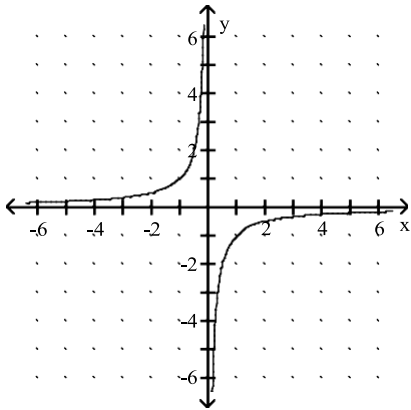

D)

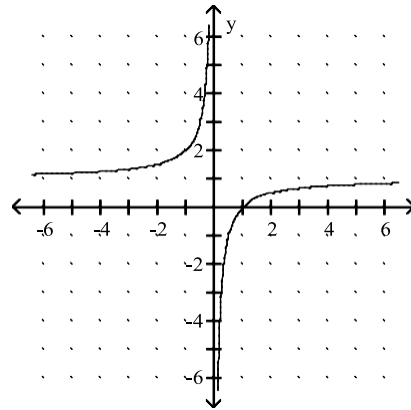

41) $y = |-9 - x|$

41) _____

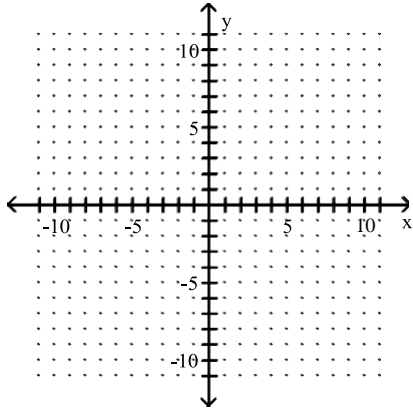

A)

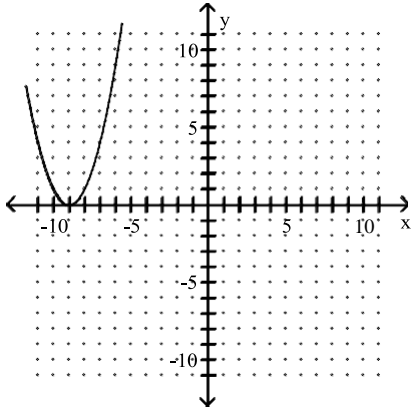

B)

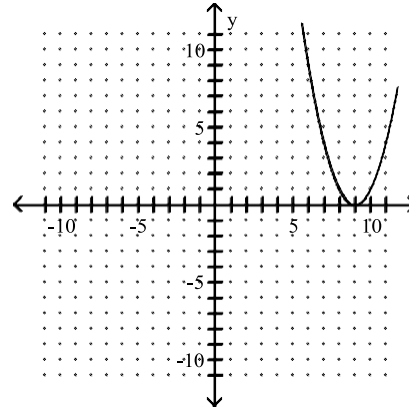

C)

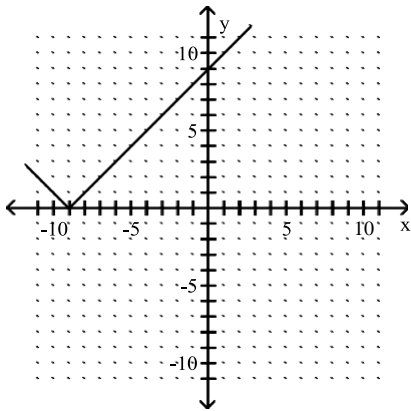

D)

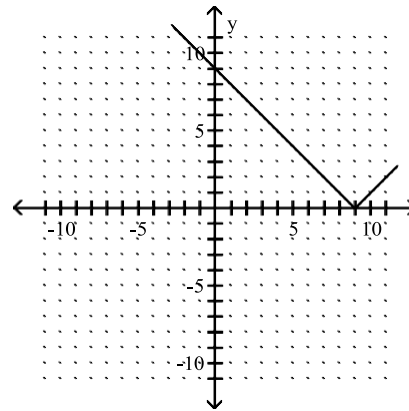

42) $y = x^3 + 5$

42) _____

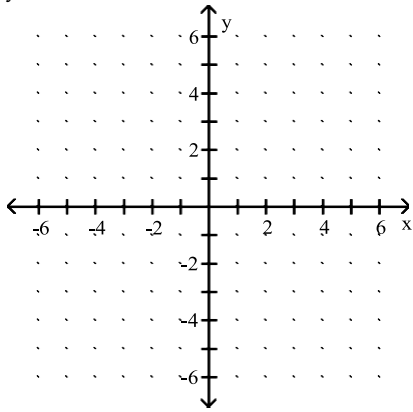

A)

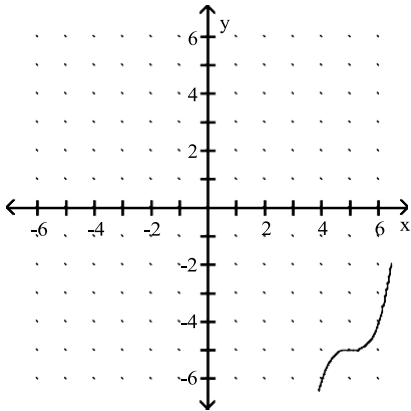

C)

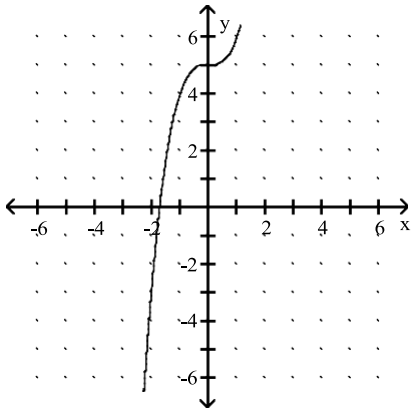

B)

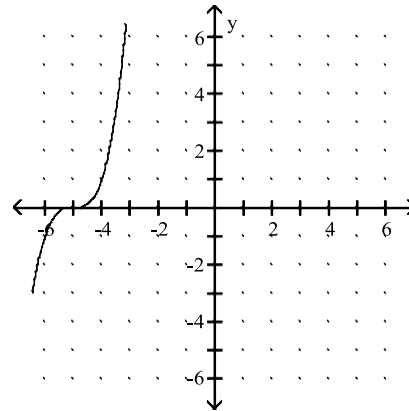

D)

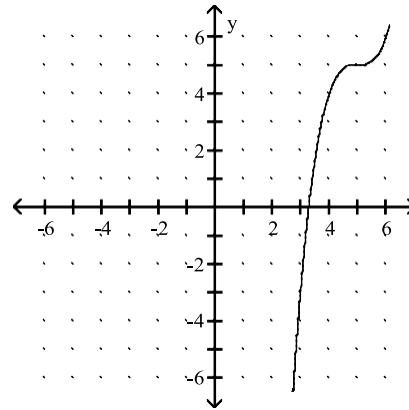

43) $y = |x| - 1$

43) _____

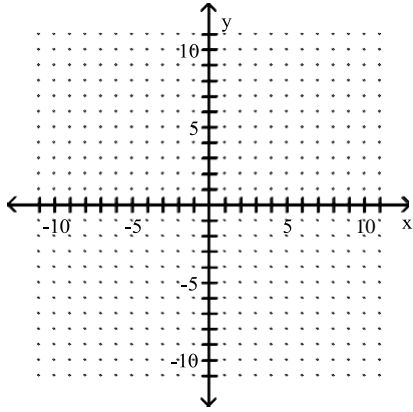

A)

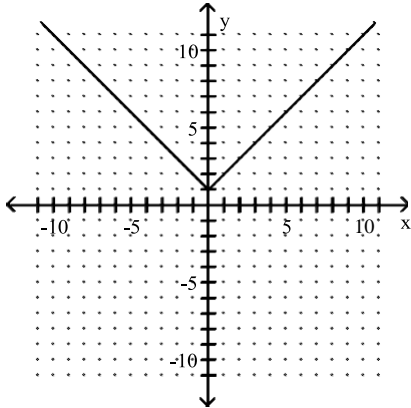

B)

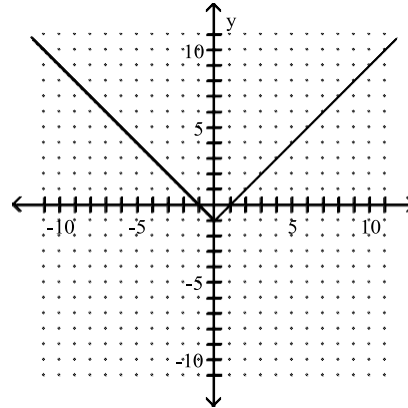

C)

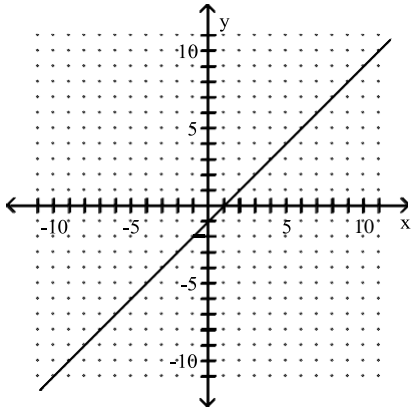

D)

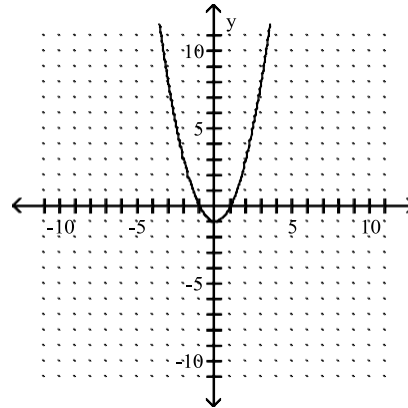

Is the following correspondence a function?

44)

44) _____

A) Yes

B) No

45)

45) _____

A) Yes

B) No

46) _____ 46) _____

A) Yes B) No

47) _____ 47) _____

A) No B) Yes

48) _____ 48) _____

A) No B) Yes

49) _____ 49) _____

A) Yes B) No

50) _____ 50) _____

A) Yes B) No

51) Domain: All students attending Laughlin Community College 51) _____

Correspondence: Each student's Social Security Number

Range: A set of Social Security Numbers

A) Yes B) No

52) Domain: All students attending the University of Ohio 52) _____

Correspondence: Each student's teachers

Range: A set of teachers

A) Yes B) No

53) _____ A) No

Name	Test Score
Bob L.	83
Susan H.	83
Jim H.	76
Bruce B.	96

B) Yes

53) _____

Find the function value.

54) Find $f(3)$ when $f(x) = -x + 8$.

A) 5

B) -5

C) 15

D) 3

54) _____

- 55) Find $f(-8)$ when $f(x) = -4x - 30$. 55) _____
 A) -30 B) 5 C) 2 D) 120
- 56) Find $f(-8)$ when $f(x) = 7x - 8$. 56) _____
 A) 64 B) -64 C) -24 D) -67
- 57) Find $g(a + 1)$ when $g(x) = 4x - 3$. 57) _____
 A) $\frac{1}{4}a - 3$ B) $4a + 1$ C) $4a - 1$ D) $4a - 3$
- 58) Find $f(12)$ when $f(x) = -9$. 58) _____
 A) 12 B) 9 C) -108 D) -9
- 59) Find $f(2)$ when $f(x) = x^2 - 3x - 2$. 59) _____
 A) 8 B) 12 C) -4 D) 0
- 60) Find $f(0)$ when $f(x) = x^2 - 2x - 3$. 60) _____
 A) 3 B) 0 C) 9 D) -3
- 61) Find $f(2a)$ when $f(x) = 4x^2 + 4x$. 61) _____
 A) $4a^2 + 8a$ B) $8a^2 + 8a$ C) $16a^2 + 4a$ D) $16a^2 + 8a$
- 62) Find $f(3)$ when $f(x) = 5x^2 - 4x - 1$. 62) _____
 A) -4 B) 56 C) 32 D) 34
- 63) Find $f(4)$ when $f(x) = |x + 8|$. 63) _____
 A) 4 B) 12 C) -12 D) -8
- 64) Find $f(8)$ when $f(x) = x^3$. 64) _____
 A) 512 B) 6561 C) 24 D) 343
- 65) Find $f(-3)$ when $f(x) = x^4 + 2$. 65) _____
 A) -79 B) 14 C) 83 D) 29

Solve the problem.

- 66) It has been determined that the number of fish $f(t)$ that can be caught in t minutes in a certain pond using a certain bait is $f(t) = .22t + 1$, for $t > 10$. Find the approximate number of fish that can be caught if you fish for 22 minutes. 66) _____
 A) About 13 fish B) About 24 fish C) About 5 fish D) About 26 fish
- 67) The function $P(d) = 1 + \frac{d}{33}$ gives the pressure, in atmospheres (atm), at a depth d feet in the sea. 67) _____
 Find the pressure at 29 feet.
 A) $\frac{29}{33}$ atm B) $\frac{10}{33}$ atm C) $\frac{4}{33}$ atm D) $\frac{62}{33}$ atm

33

11

33

33

- 68) The function F described by $F(C) = \frac{9}{5}C + 32$ gives the Fahrenheit temperature corresponding to the Celsius temperature C . Find the Fahrenheit temperature equivalent to -15°C .
- A) -49°F B) 5°F C) -22°F D) -76°F

68) _____

Graph the function.

69) $f(x) = x - 5$

69) _____

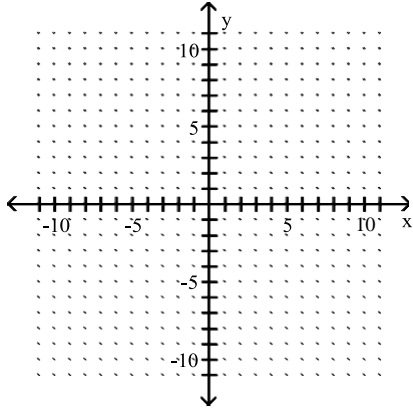

A)

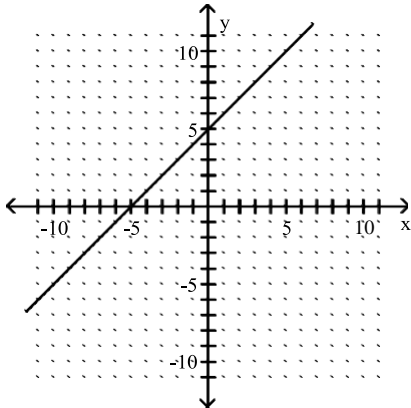

C)

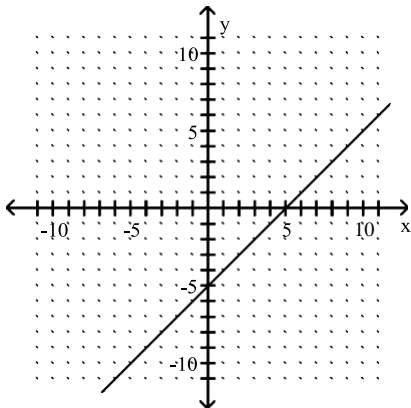

B)

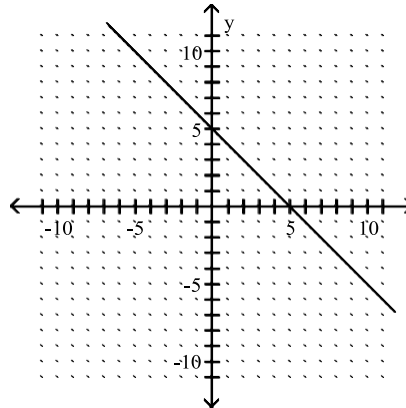

D)

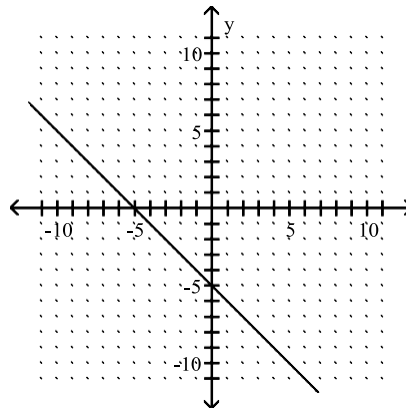

70) $y = -3x - 5$

70) _____

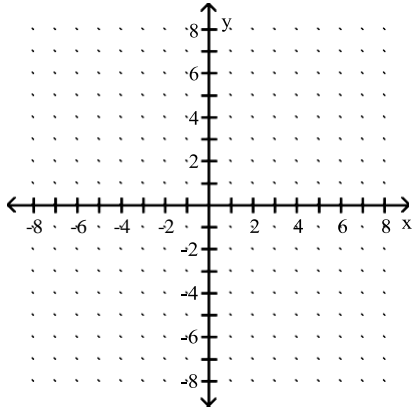

A)

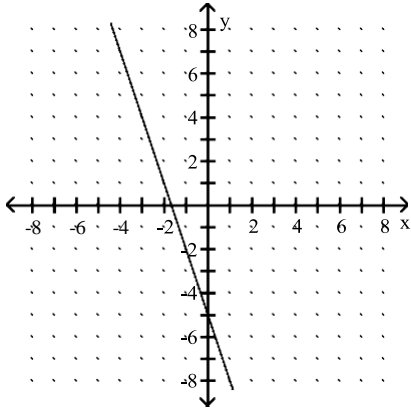

B)

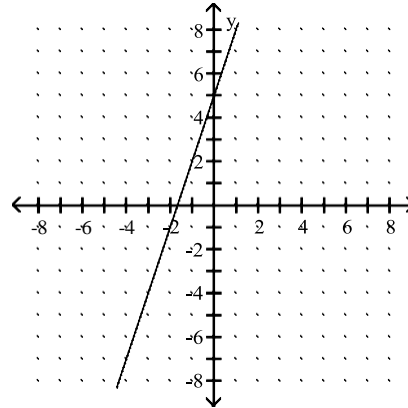

C)

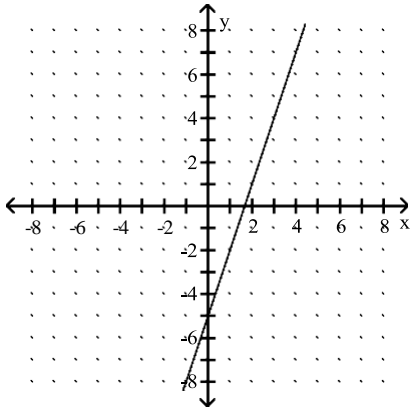

D)

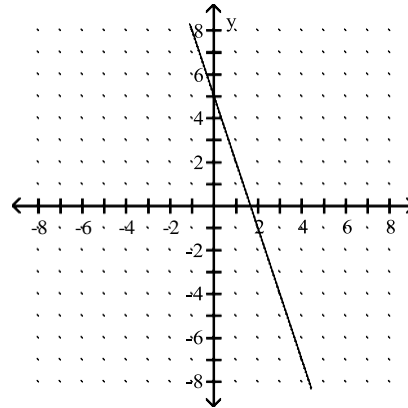

71) $f(x) = \frac{1}{5}x + 2$

71) _____

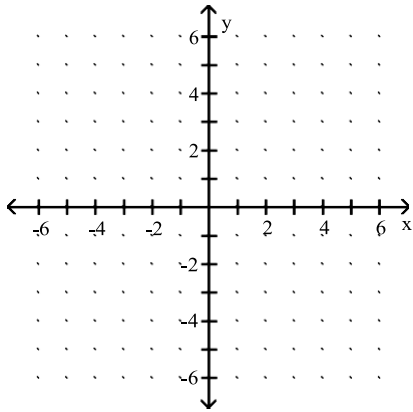

A)

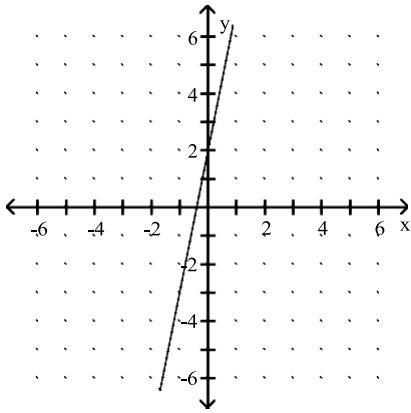

B)

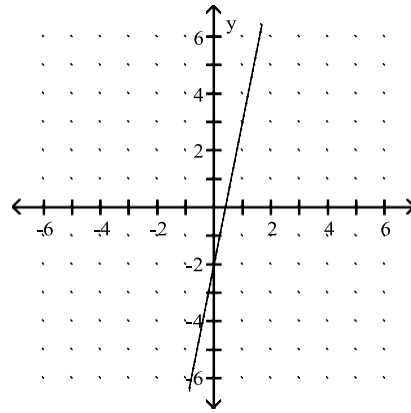

C)

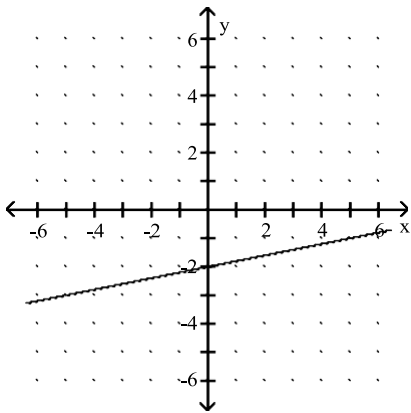

D)

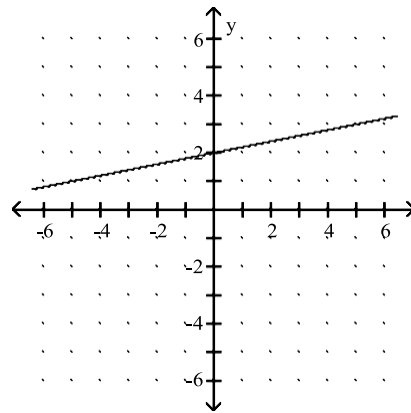

72) $f(x) = x^2 + 2$

72) _____

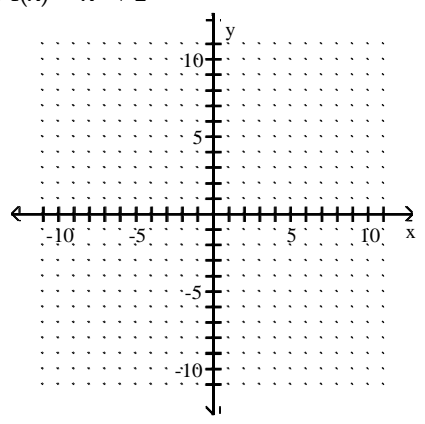

A)

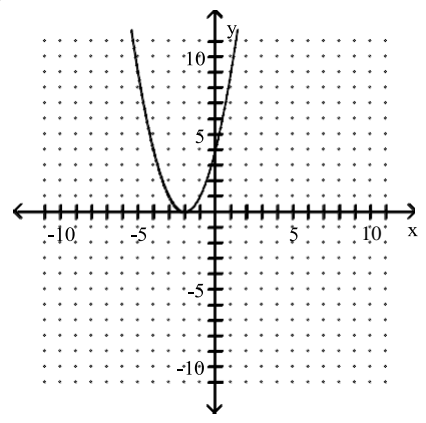

B)

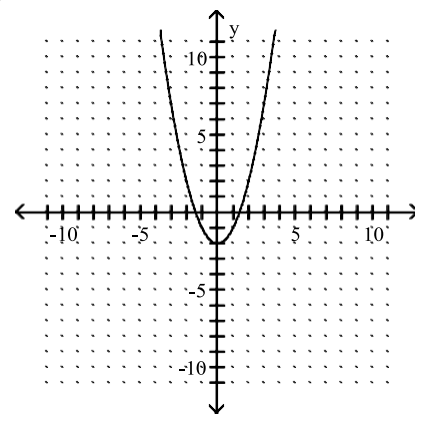

C)

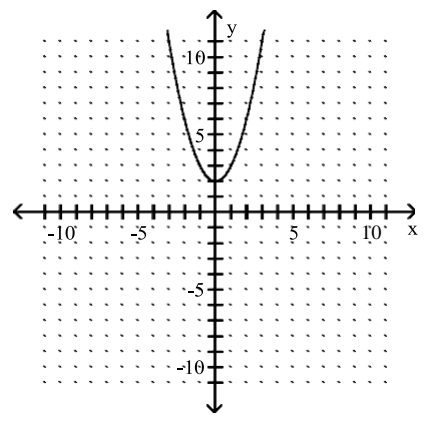

D)

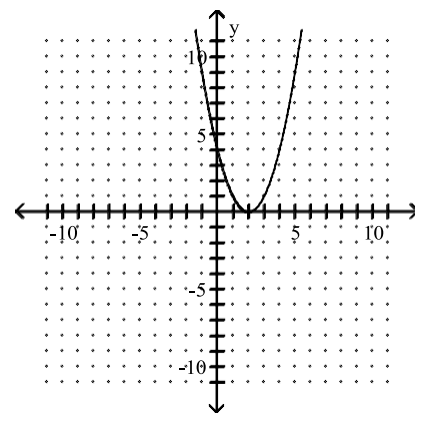

73) $f(x) = x^2 + 2x - 9$

73) _____

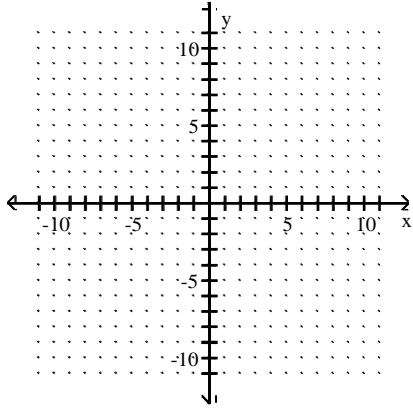

A)

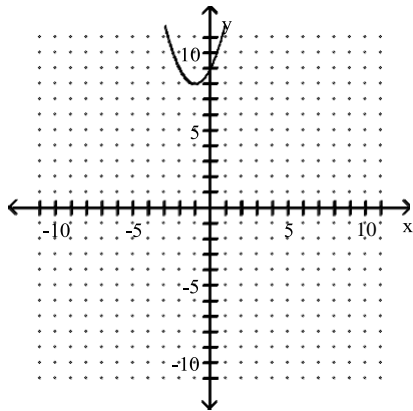

B)

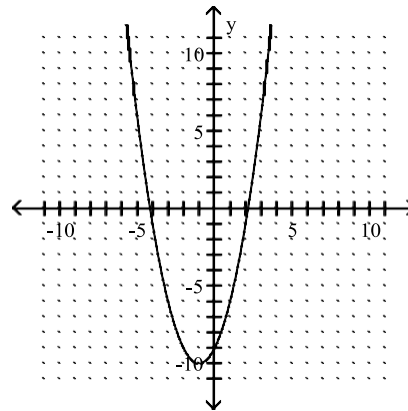

C)

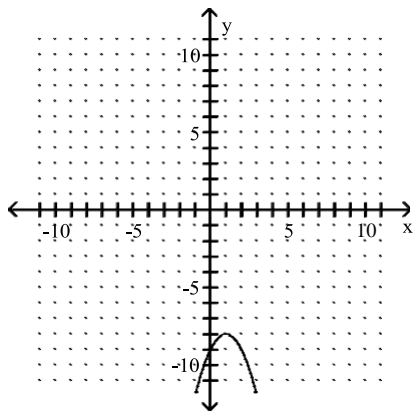

D)

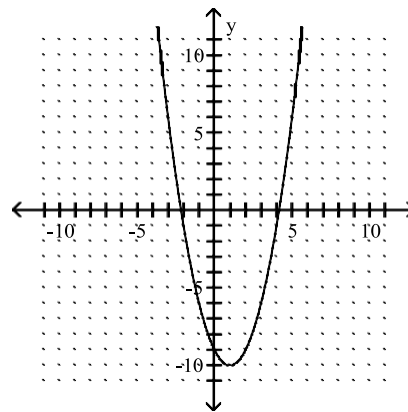

74) $f(x) = -x^2 + 3x - 9$

74) _____

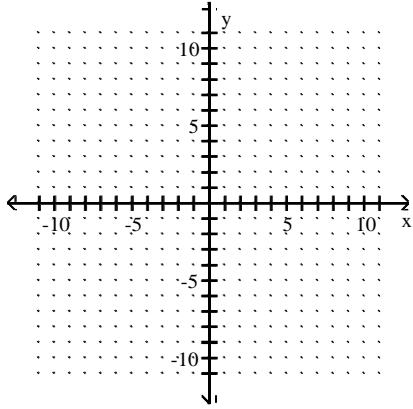

A)

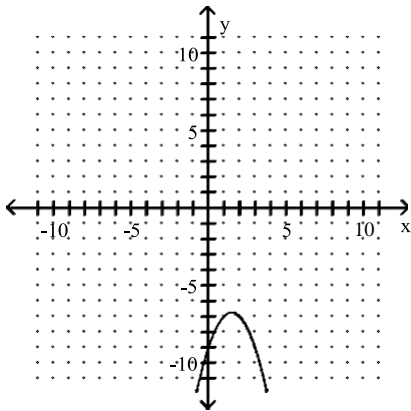

B)

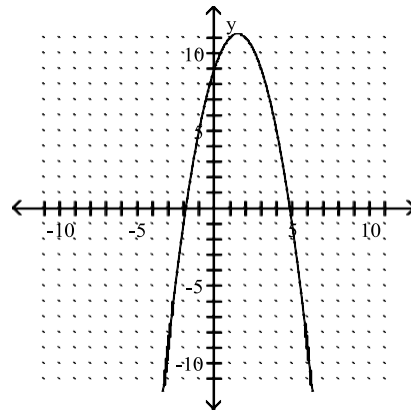

C)

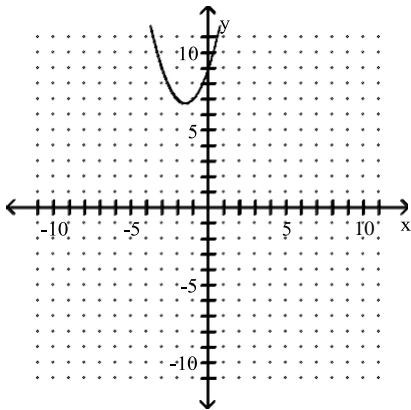

D)

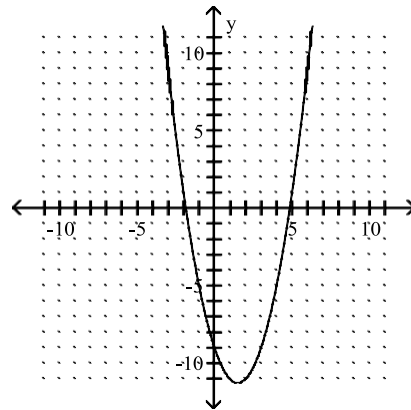

75) $f(x) = -4 - x^2$

75) _____

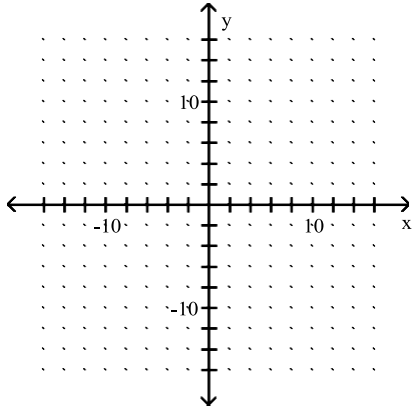

A)

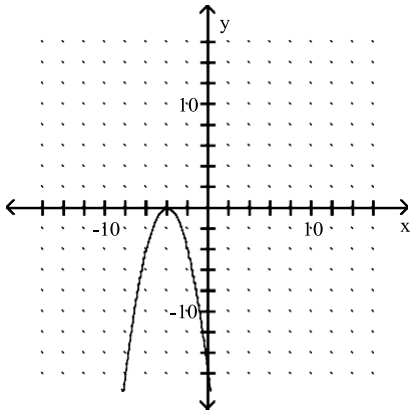

B)

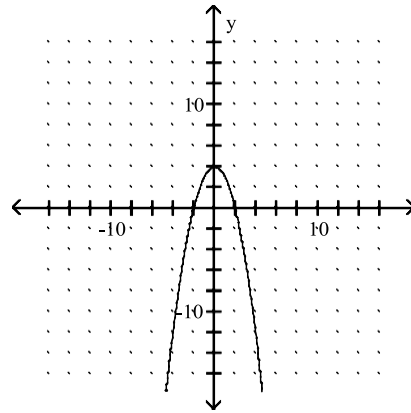

C)

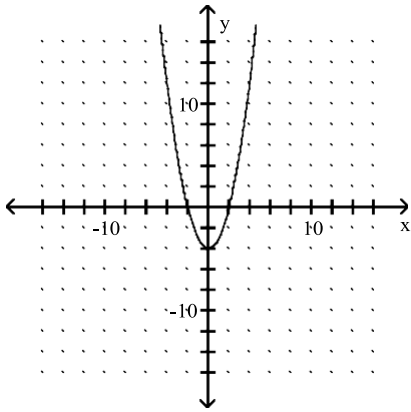

D)

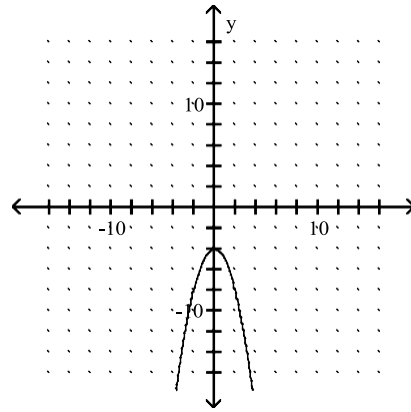

76) $f(x) = |-1 - x|$

76) _____

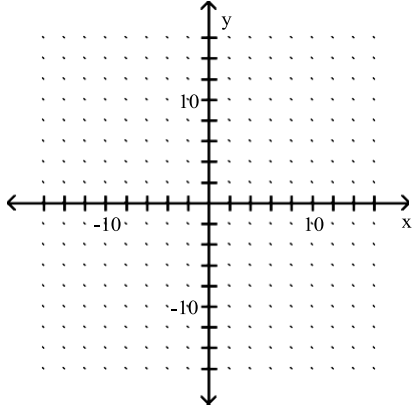

A)

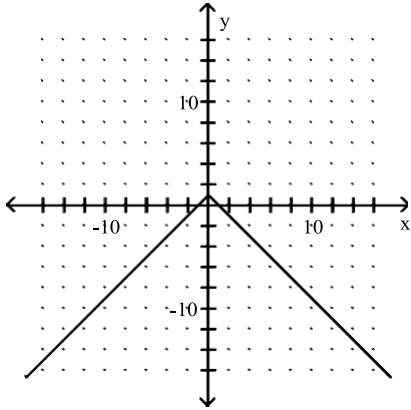

B)

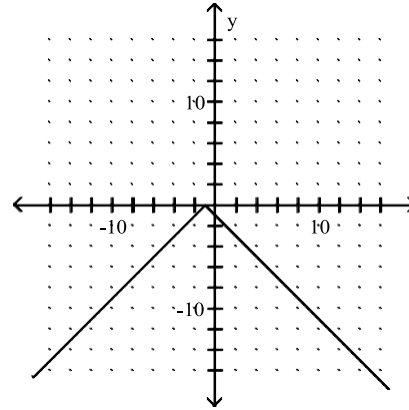

C)

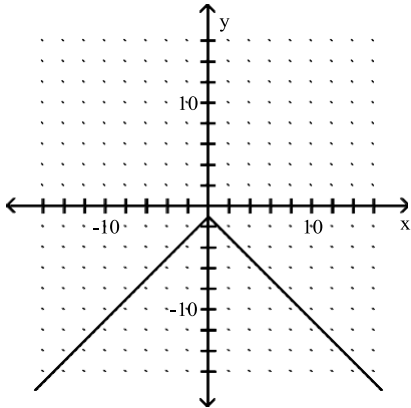

D)

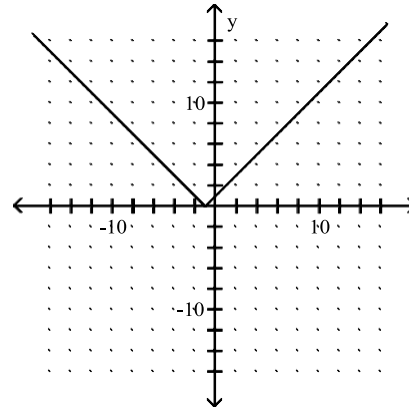

77) $f(x) = |x| + 2$

77) _____

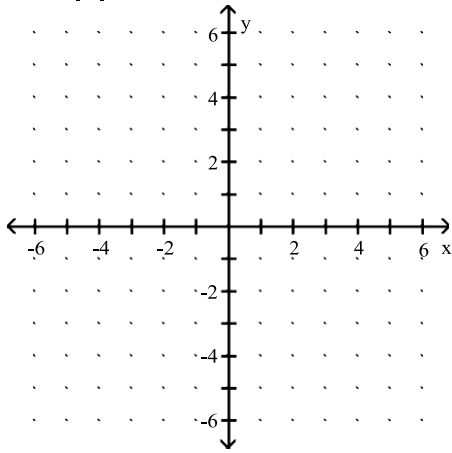

A)

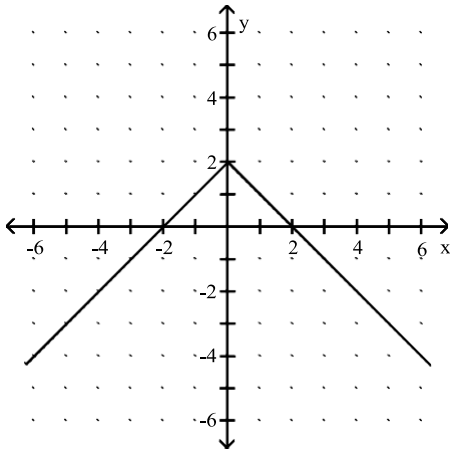

B)

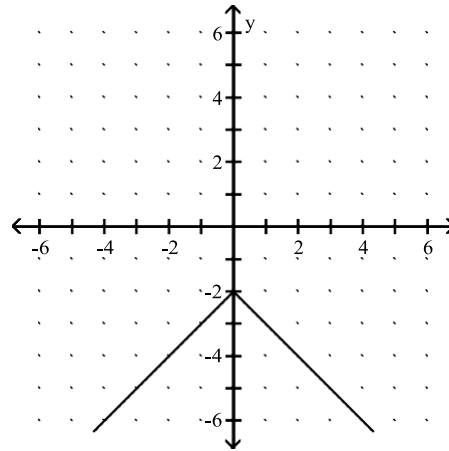

C)

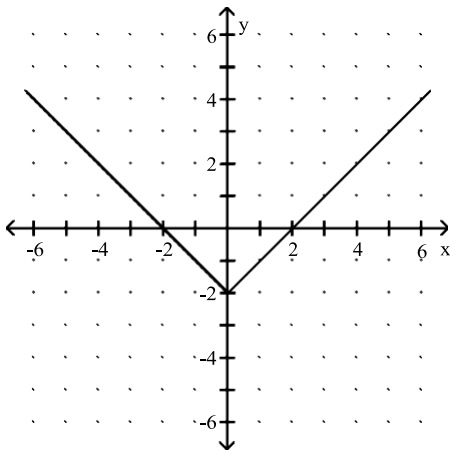

D)

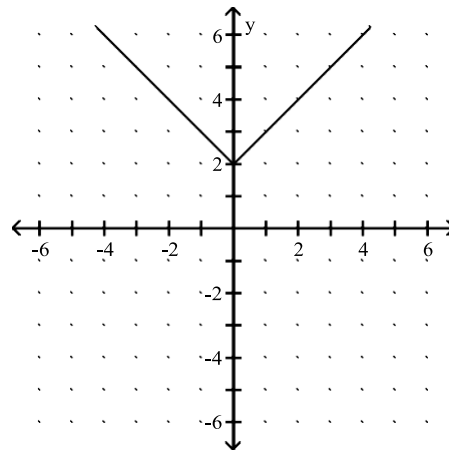

78) $f(x) = x^3 - 2$

78) _____

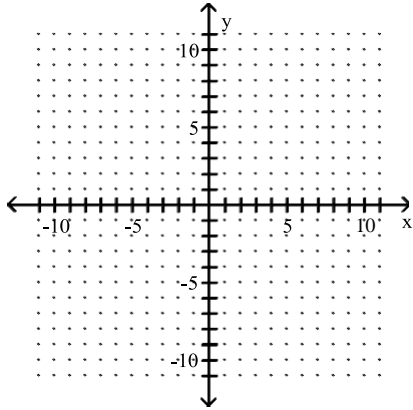

A)

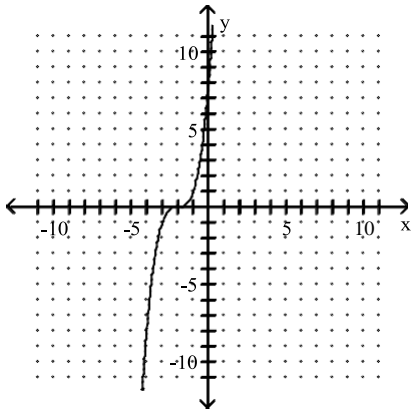

B)

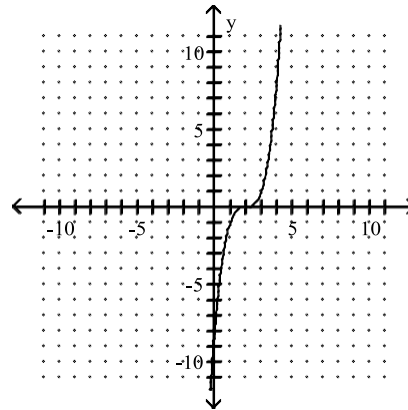

C)

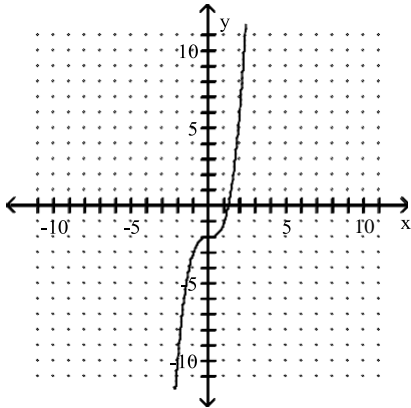

D)

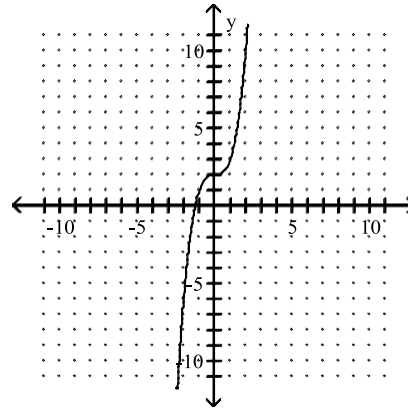

Determine whether the graph is the graph of a function.

79)

79) _____

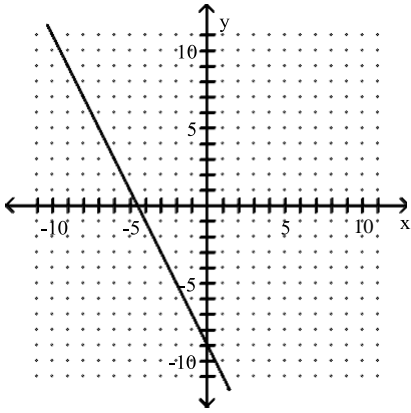

A) Not a function

B) Function

80)

80) _____

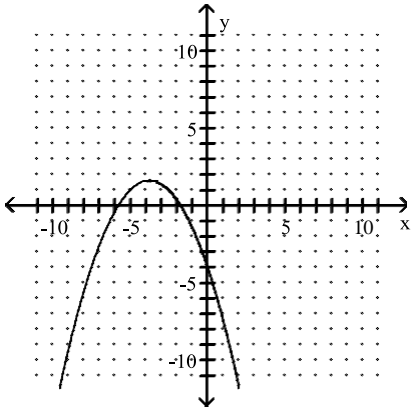

A) Function

B) Not a function

81)

81) _____

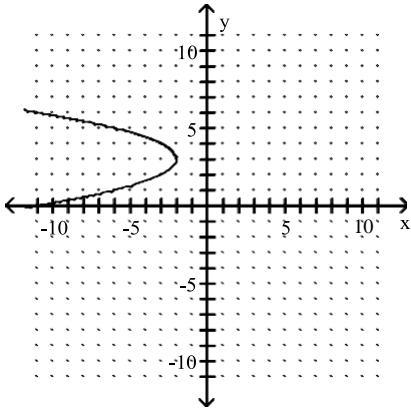

A) Not a function

B) Function

82)

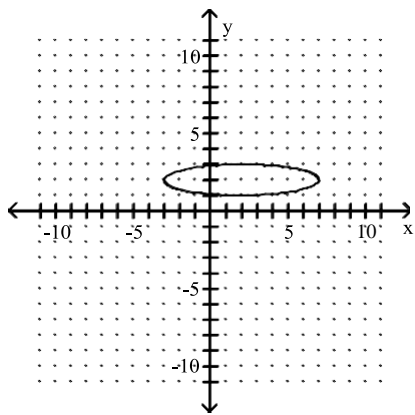

A) Function

B) Not a function

82) _____

83)

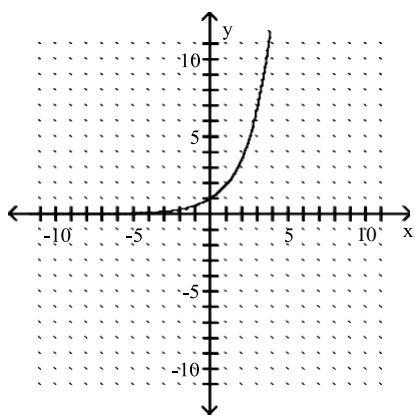

A) Not a function

B) Function

83) _____

84)

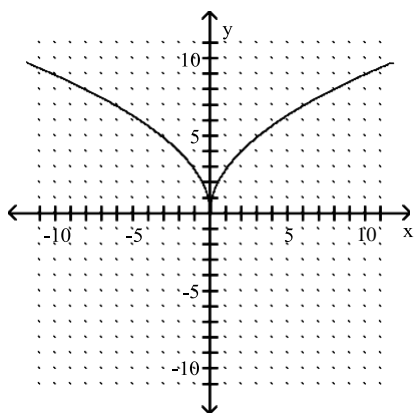

A) Not a function

B) Function

84) _____

Solve.

85) Cars sold

85) _____

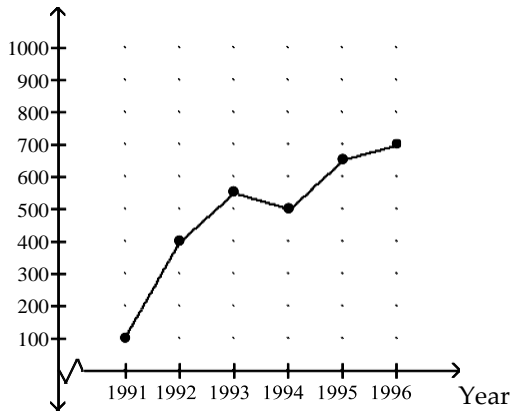

Crafty Bill's Cool Car Sales opened as a used car sales lot in 1991. The graph shows the number of cars sold as a function of time. What is the approximate number of cars sold in 1993?

- A) 350 cars B) 500 cars C) 400 cars D) 550 cars

86) Cars sold

86) _____

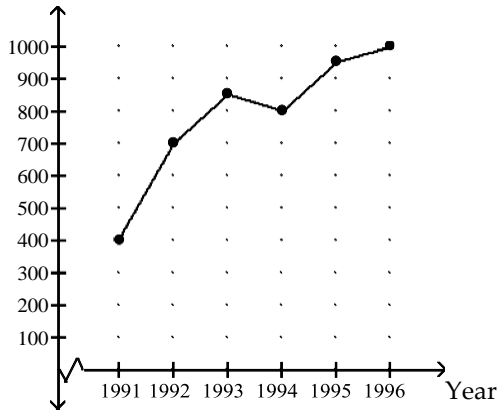

Crafty Bill's Cool Car Sales opened as a used car sales lot in 1991. The graph shows the number of cars sold as a function of time. What is the approximate number of cars sold in 1995?

- A) 900 cars B) 600 cars C) 150 cars D) 950 cars

87) The height h in feet of a projectile thrown upward from the roof of a building after time t seconds is shown in the graph below. How high will the projectile be after 2.7 seconds?

87) _____

Height (in ft)

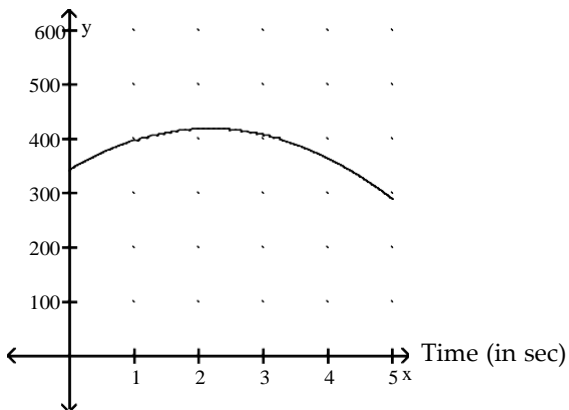

A) 450 ft

B) 400 ft

C) 425 ft

D) 475 ft

88) The surface area a of a cylinder is shown in the graph below. What is the radius if the surface area is 30 m^2 ? 88) _____

Surface Area (in m^2)

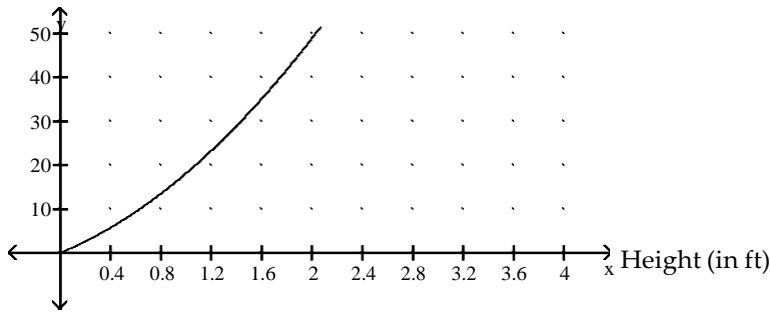

- A) 1.2 m B) 1.6 m C) 1.4 m D) 1.8 m

89) The graph shows the relationship between the area A of a rectangle and the length L , if the width is fixed. Find the area if the length is 20 cm. 89) _____

Area (in cm^2)

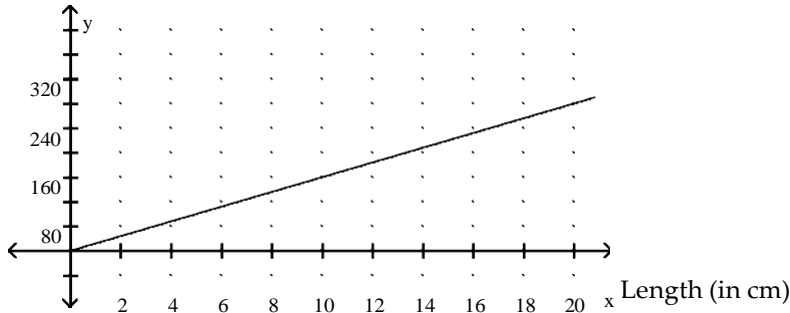

- A) 240 cm^2 B) 216 cm^2 C) 264 cm^2 D) 204 cm^2

For the function represented in the graph, determine the domain or range, as requested.

90) Find the domain. 90) _____

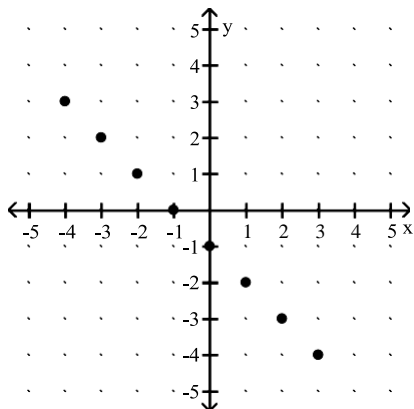

- A) $\{-4, -3, -2, -1, 0, 1, 2, 3\}$ B) $[-4, 4]$
 C) $[-2, 2]$ D) $\{-5, -4, -3, -2, -1, 0, 1, 2, 3\}$

91) Find the domain.

91) _____

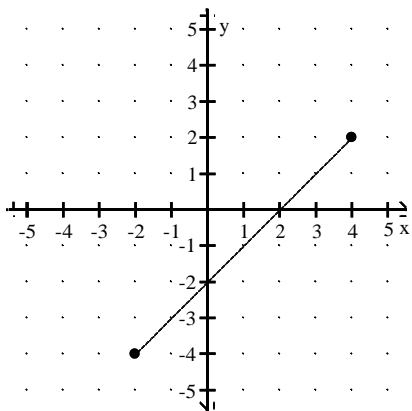

A) $[-5, 5]$

B) $[-2, 4]$

C) $[3, -3]$

D) $[-4, 6]$

92) Find the domain.

92) _____

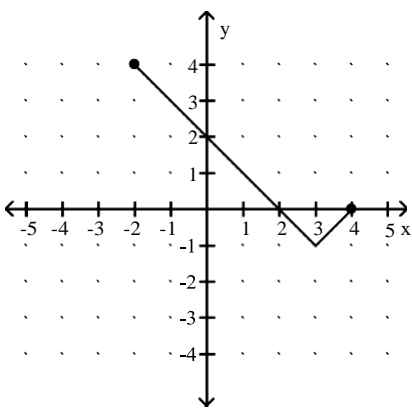

A) $[0, 4]$

B) $[-2, 4]$

C) $\{-5, -4, -3, -2, -1, 0, 1, 2, 3, 4, 5\}$

D) $[-2, 2]$

93) Find the range.

93) _____

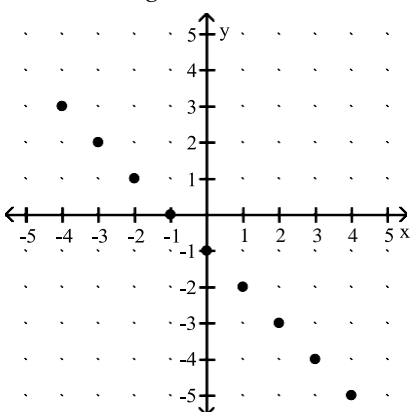

A) $[-1, 1]$

B) $\{-4, -3, -2, -1, 0, 1, 2, 3, 4\}$

C) $[-5, 3]$

D) $\{-5, -4, -3, -2, -1, 0, 1, 2, 3\}$

94) Find the range.

94) _____

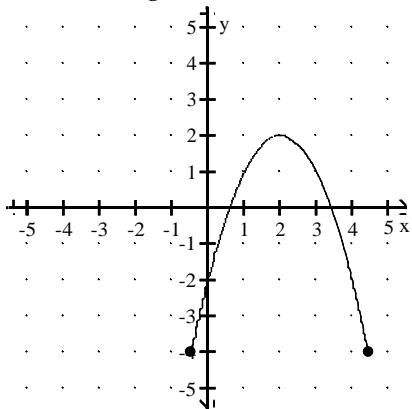

A) $[-5, 5]$

B) $[-4, 2]$

C) $[-0.45, 4.45]$

D) $[-2, 2]$

95) Find the range.

95) _____

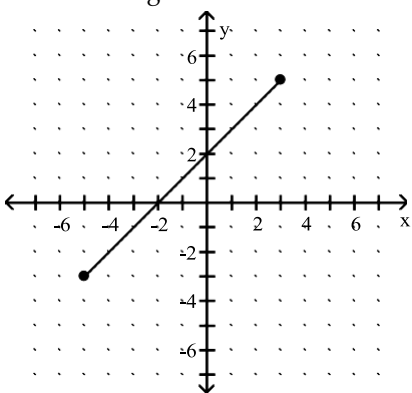

A) $[-5, 5]$

B) $\{-3, -2, -1, 0, 1, 2, 3, 4, 5\}$

C) $[-3, 5]$

D) $[-5, 3]$

96) Find the range.

96) _____

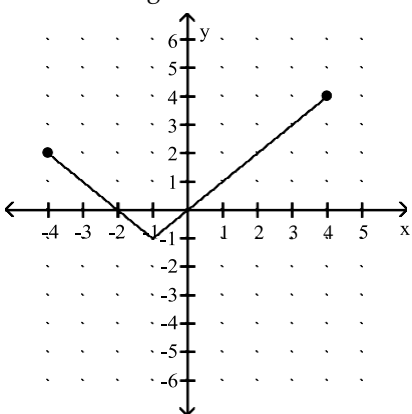

A) $[2, 4]$

B) $[-1, 4]$

C) $\{-5, -4, -3, -2, -1, 0, 1, 2, 3, 4, 5\}$

D) $[1, -1]$

97) Find the domain.

97) _____

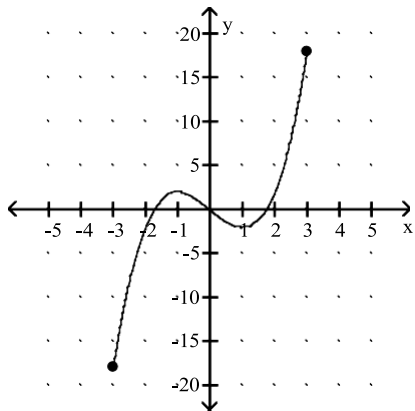

- A) all real numbers
- B) $[-5, 5]$
- C) $[-18, 18]$
- D) $[-3, 3]$

98) Find the domain.

98) _____

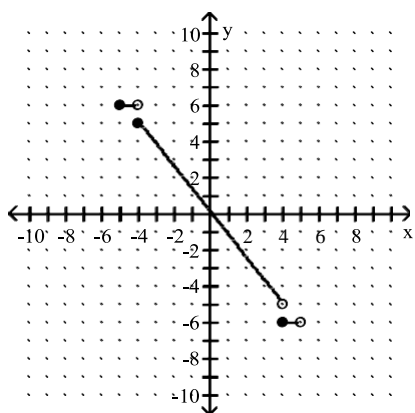

- A) $[-4, 4]$
- B) $[-5, 5]$
- C) $[-5, 5]$
- D) $(-5, 5)$

99) Find the range.

99) _____

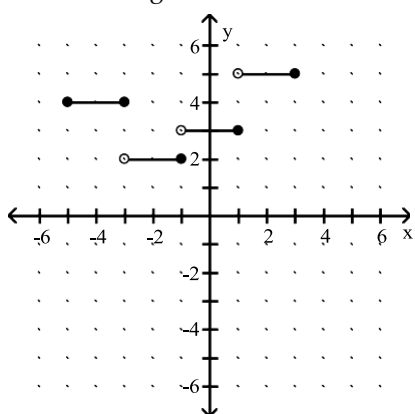

- A) $\{-5, -3, -1, 1, 3\}$
- B) $[2, 5]$
- C) $\{2, 3, 4, 5\}$
- D) $[-5, 3]$

The graph of a function f is provided. Determine the requested function value.

100) $f(-4)$

100) _____

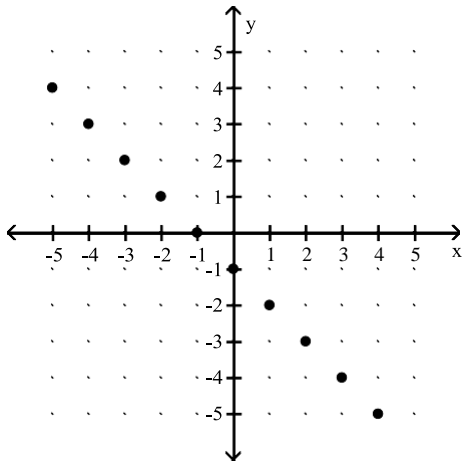

A) 5

B) 3

C) -5

D) -3

101) $f(-2)$

101) _____

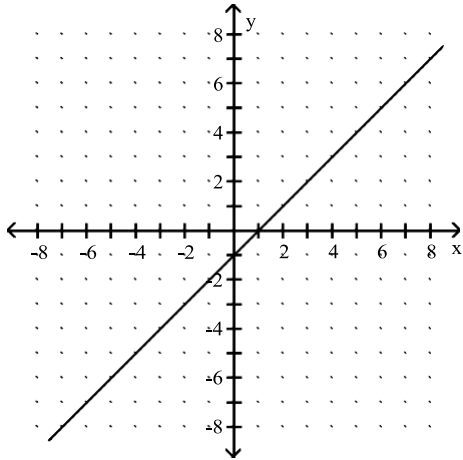

A) -1

B) 3

C) -3

D) -2

102) $f(5)$

102) _____

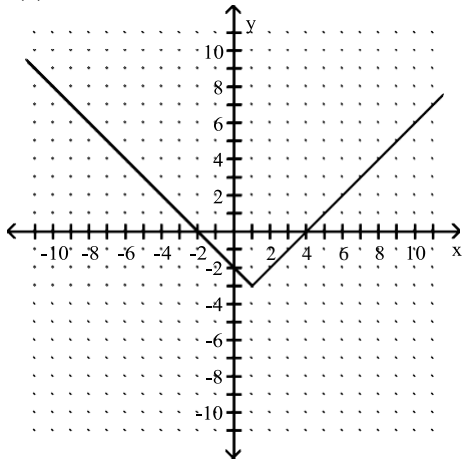

A) 7

B) 3

C) 9

D) 1

103) $f(1)$

103) _____

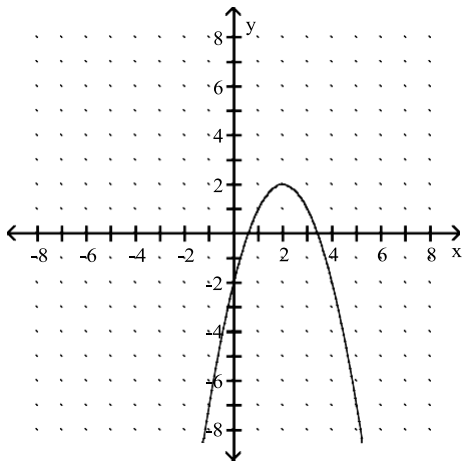

A) -3

B) -23

C) 3

D) 1

104) $f(2)$

104) _____

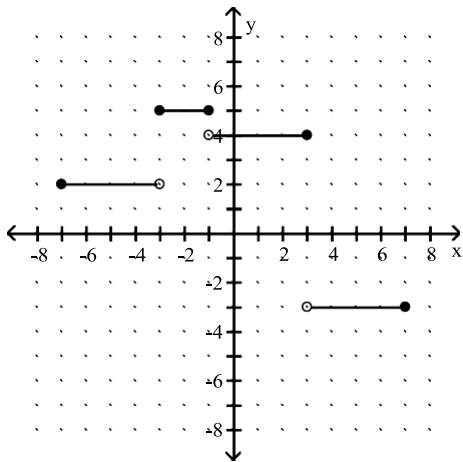

A) 4

B) -3

C) 5

D) 2

A function f is depicted in the graph. Find any input values that produce the indicated output.

105) $f(x) = 2$

105) _____

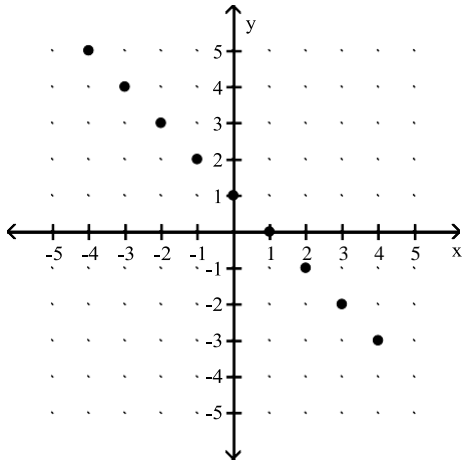

A) 1

B) 0

C) -1

D) 2

106) $f(x) = 3$

106) _____

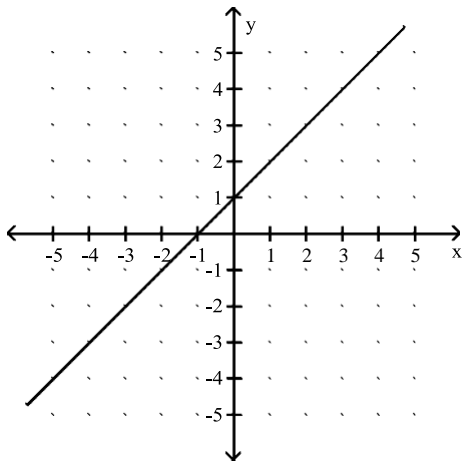

A) -2

B) 2

C) 4

D) -1

107) $f(x) = -1$

107) _____

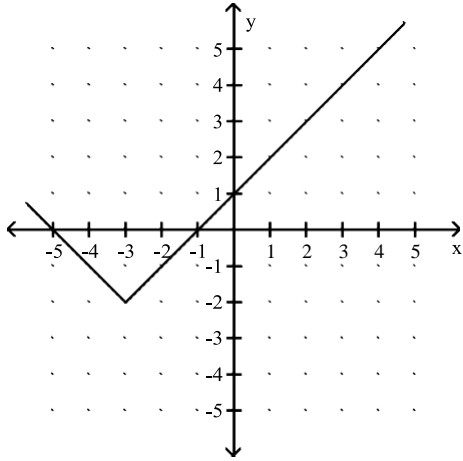

- A) $x = 4$ and $x = 2$
- C) $x = -4$

- B) $x = -4$ and $x = -2$
- D) $x = -6$ and $x = 0$

108) $f(x) = -2$

108) _____

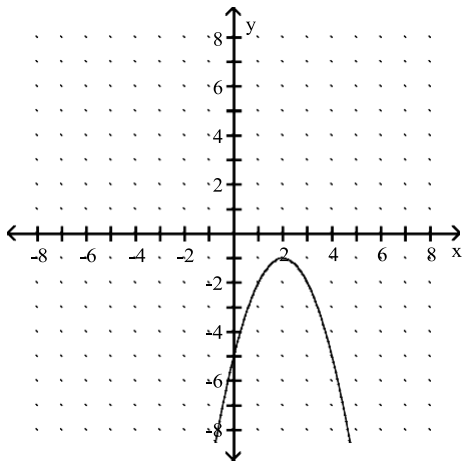

A) $x = 1$

B) $x = 0$ and $x = 4$

C) $x = 3$ and $x = 1$

D) $x = 3$

109) $f(x) = -4$

109) _____

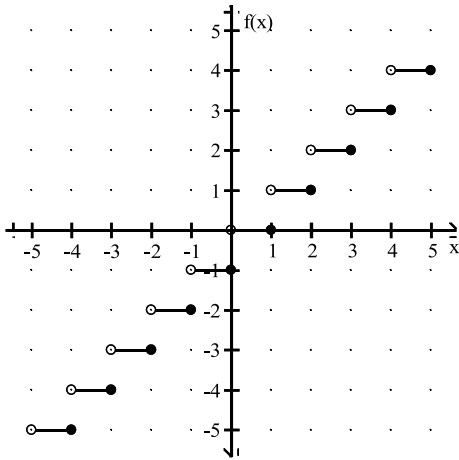

- A) $\{x \mid -4 \leq x \leq -3\}$ B) $\{x \mid -4 < x \leq -3\}$ C) -3 D) $\{x \mid -4 < x < -3\}$

Find the domain.

110) $f(x) = \frac{-6}{x+9}$

110) _____

- A) $\{x \mid x \text{ is a real number and } x \neq 9\}$ B) $\{x \mid x \text{ is a real number and } x \neq -6\}$
 C) $\{x \mid x \text{ is a real number and } x \neq 6\}$ D) $\{x \mid x \text{ is a real number and } x \neq -9\}$

111) $f(x) = \frac{3}{-8-x}$

111) _____

- A) $\{x \mid x \text{ is a real number and } x \neq -3\}$ B) $\{x \mid x \text{ is a real number and } x \neq 3\}$
 C) $\{x \mid x \text{ is a real number and } x \neq 8\}$ D) $\{x \mid x \text{ is a real number and } x \neq -8\}$

112) $f(x) = -8x + 9$

112) _____

- A) $\{x \mid x \text{ is a real number and } x \neq -8\}$ B) All real numbers
 C) $\{x \mid x \text{ is a real number and } x \neq 1.125\}$ D) $\{x \mid x \text{ is a real number and } x \neq 9\}$

113) $f(x) = -3x - 1$

113) _____

- A) $\{x \mid x \text{ is a real number and } x \neq -6\}$ B) $\{x \mid x \text{ is a real number and } x \neq 6\}$
 C) All real numbers D) $\{x \mid x \text{ is a real number and } x \neq 0.16666667\}$

114) $f(x) = x^2 - 2$

114) _____

- A) All real numbers B) $\{x \mid x \text{ is a real number and } x \neq 2\}$
 C) $\{x \mid x \text{ is a real number and } x \neq -2\}$ D) $\{x \mid x \text{ is a real number and } x \neq \sqrt{-2}\}$

115) $f(x) = |6x + 7|$

- A) $\{x \mid x \text{ is a real number and } x \neq -0.8571429\}$ B) $\{x \mid x \text{ is a real number and } x \neq -1.16666667\}$
 C) $\{x \mid x \text{ is a real number and } x \neq -7\}$ D) All real numbers

116) $f(x) = \frac{1}{|45-x|}$

- A) $\{x \mid x \text{ is a real number and } x < 45\}$ B) $\{x \mid x \text{ is a real number and } x \neq 45\}$

C)
All
rea
l
nu
m
ber
s

109) $f(x) = -4$

109) _____

D) $\{x \mid x \text{ is a real number and } x \neq -45\}$

115) _____

116) _____

117) $f(x) = x^3 - 3$

- A) $\{x \mid x \text{ is a real number and } x \neq -3\}$
- C) $\{x \mid x \text{ is a real number and } x \neq \sqrt[3]{-3}\}$

- B) All real numbers
- D) $\{x \mid x \text{ is a real number and } x \neq 3\}$

117) _____

Find the function value.

118) $f(-2)$

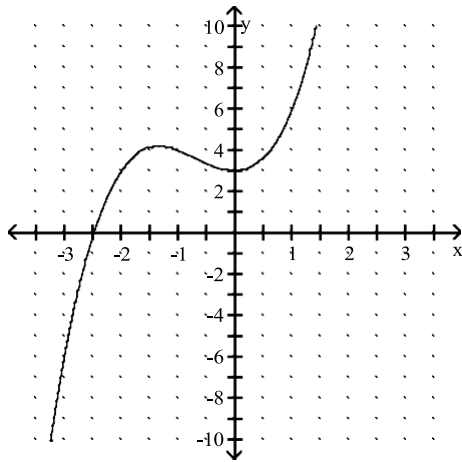

- A) 4
- B) 5
- C) 1
- D) 3

118) _____

119) $f(1)$

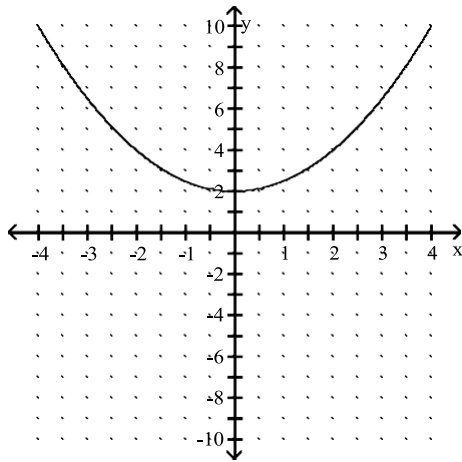

- A) 3.5
- B) 2.5
- C) 0.5
- D) 4.5

119) _____

Determine the slope and the y-intercept.

120) $y = 7x + 3$

- A) Slope -7, y-intercept (0, 3)
- C) Slope 7, y-intercept (0, 3)

- B) Slope 3, y-intercept (0, 7)
- D) Slope 3, y-intercept (0, -7)

120) _____

121) $f(x) = -7x - 4$

- A) Slope -7, y-intercept (0, -4)
- C) Slope -4, y-intercept (0, -7)

- B) Slope -4, y-intercept (0, 7)
- D) Slope 7, y-intercept (0, -4)

121) _____

122) $y = 4x - 0.3$

- A) Slope -0.3, y-intercept (0, 4)
- C) Slope 4, y-intercept (0, 0.3)

- B) Slope -4, y-intercept (0, -0.3)
- D) Slope 4, y-intercept (0, -0.3)

122) _____

123) $y = -3.9x - 5$

- A) Slope -3.9, y-intercept (0, -5)
- C) Slope -5, y-intercept (0, -3.9)

- B) Slope 3.9, y-intercept (0, -5)
- D) Slope -5, y-intercept (0, 3.9)

123) _____

124) $2x - 6y = -6$

- A) Slope -3, y-intercept (0, 1)
- C) Slope 3, y-intercept (0, -1)

- B) Slope $-\frac{1}{3}$, y-intercept (0, -1)
- D) Slope $\frac{1}{3}$, y-intercept (0, 1)

124) _____

125) $4x - 5y + 5 = 0$

- A) Slope $-\frac{4}{5}$, y-intercept (0, -1)
- C) Slope $-\frac{5}{4}$, y-intercept (0, 1)

- B) Slope $\frac{4}{5}$, y-intercept (0, 1)
- D) Slope $\frac{5}{4}$, y-intercept (0, -1)

125) _____

126) $19y + 4x + 7 = \frac{3}{4} + 4x$

- A) Slope $\frac{19}{4}$, y-intercept (0, $-\frac{4}{19}$)
- C) Slope 0, y-intercept (0, $\frac{4}{19}$)

- B) Slope 0, y-intercept (0, $-\frac{4}{19}$)
- D) Slope $-\frac{4}{19}$, y-intercept (0, $-\frac{16}{19}$)

126) _____

Find the slope of the line.

127)

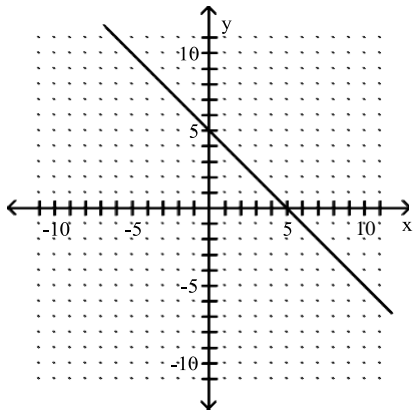

- A) -1
- B) 1
- C) -5
- D) 5

127) _____

128)

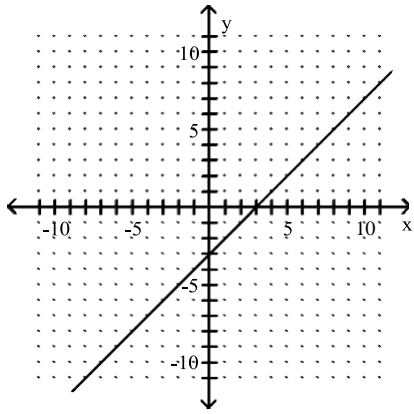

A) -1

B) 1

C) 3

D) -3

128) _____

129)

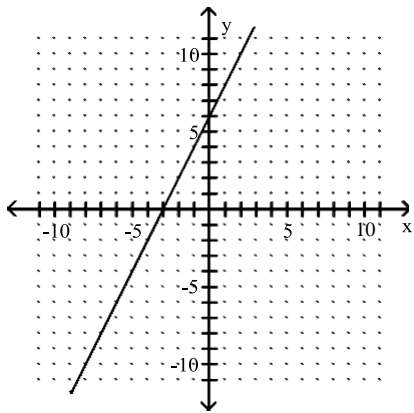

A) $-\frac{1}{2}$

B) $\frac{1}{2}$

C) -2

D) 2

129) _____

130)

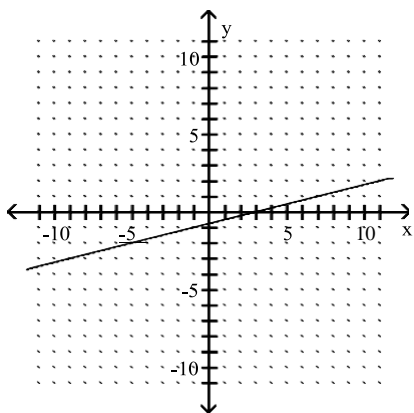

A) -4

B) $\frac{1}{4}$

C) 4

D) $-\frac{1}{4}$

130) _____

Find the slope of the line containing the two given points.

131) (8, 1) and (9, 4)

A) -3

B) 3

C) $\frac{1}{3}$

D) $\frac{5}{17}$

131) _____

132) (-2, 5) and (-9, -8)

A) $\frac{7}{13}$

B) $\frac{13}{7}$

C) $\frac{3}{11}$

D) $\frac{13}{7}$

132) _____

133) (-7, 1) and (-6, 1)

A) 2

B) Undefined

C) $-\frac{2}{13}$

D) 0

133) _____

134) (-5, -4) and (13, 3)

A) $-\frac{7}{18}$

B) $\frac{7}{18}$

C) $-\frac{1}{8}$

D) $\frac{18}{7}$

134) _____

135) (8.1, -12.8) and (0.5, -8.6)

A) $\frac{21}{38}$

B) $\frac{38}{21}$

C) $-\frac{38}{21}$

D) $-\frac{21}{38}$

135) _____

Find the slope (or rate of change). Use appropriate units.

136) Find the slope (or pitch) of the roof.

136) _____

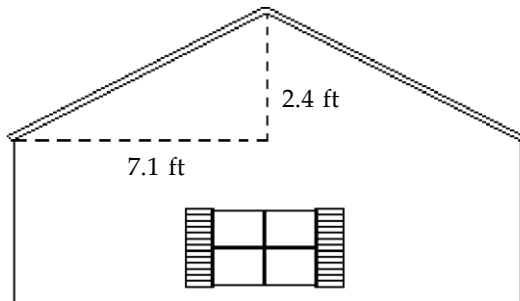

A) 0.34%

B) 295.8%

C) 33.8%

D) 2.96%

137)

137) _____

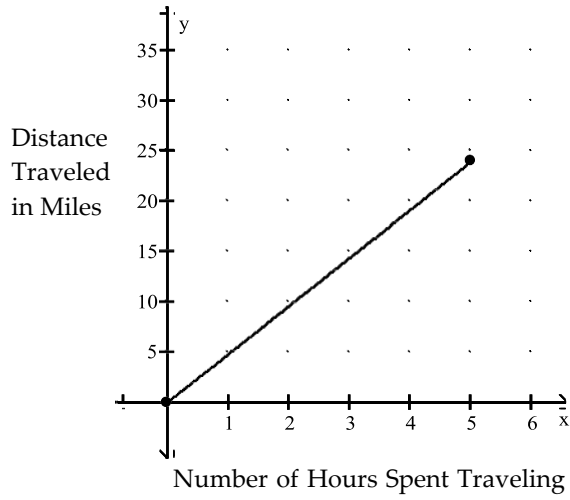

- A) 0.4 miles per hour
- B) 0.2 miles per hour
- C) 2.8 miles per hour
- D) 4.8 miles per hour

138)

138) _____

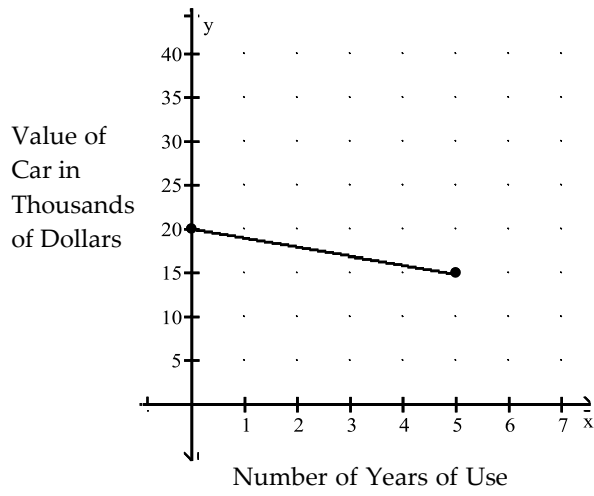

- A) -\$1000 per year
- B) -\$2000 per year
- C) \$2000 per year
- D) \$1000 per year

139)

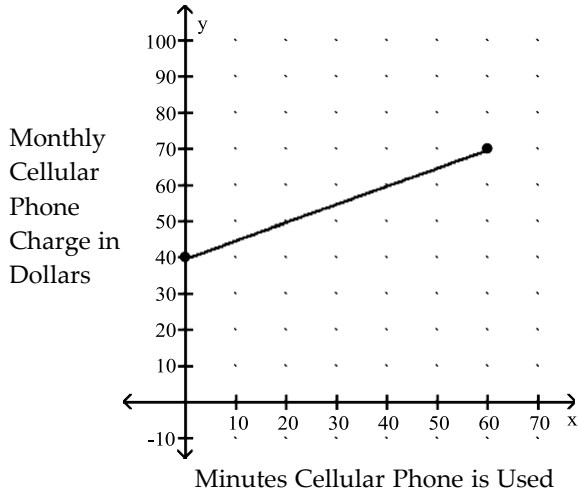

- A) \$2.25 per minute
 B) \$0.50 per minute
 C) \$0.29 per minute
 D) \$2.00 per minute

139) _____

Find the intercepts and then graph the line.

140) $15y - 3x = -6$

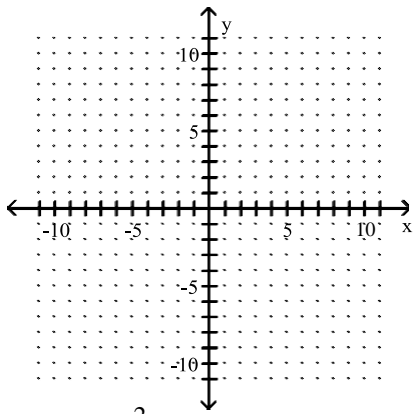

- A) $(0, -\frac{2}{5}); (2, 0)$
 B) $(0, \frac{2}{5}); (-2, 0)$

140) _____

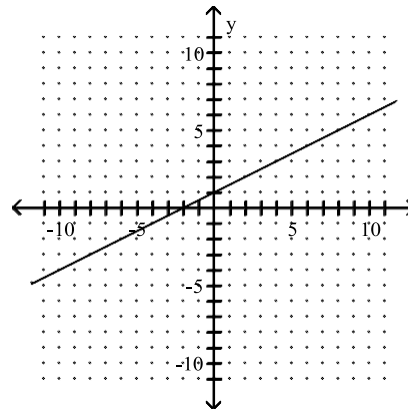
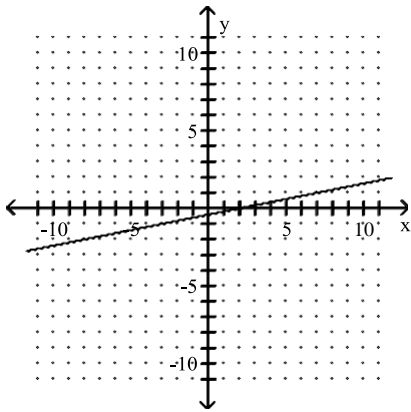

C) $(0, -\frac{2}{5}); (-2, 0)$

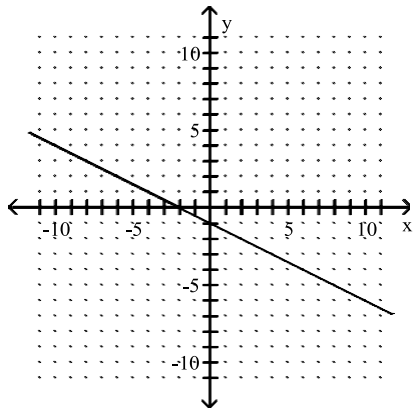

D) $(0, \frac{2}{5}); (2, 0)$

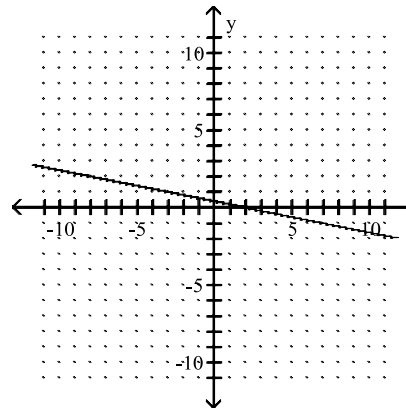

141) $-2x - 10y = 10$

141) _____

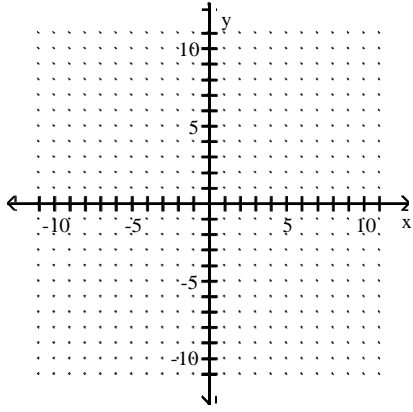

A) $(0, 1); (-5, 0)$

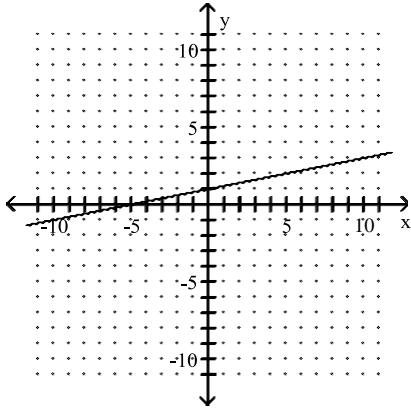

B) $(0, -1); (5, 0)$

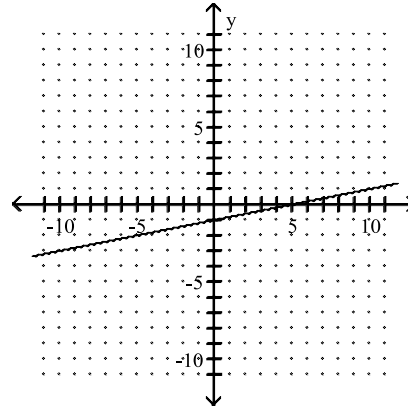

C) $(0, 1); (5, 0)$

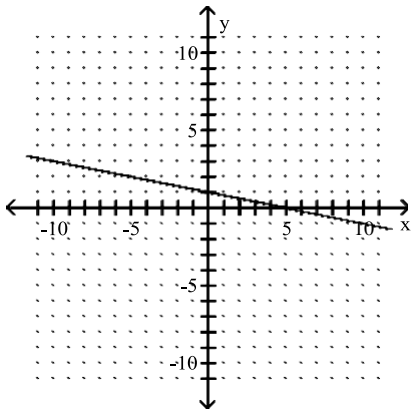

D) $(0, -1); (-5, 0)$

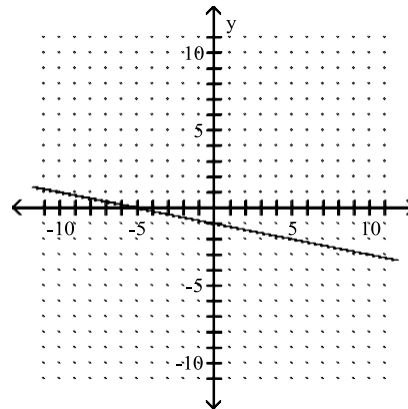

142) $x - 3y = 3$

142) _____

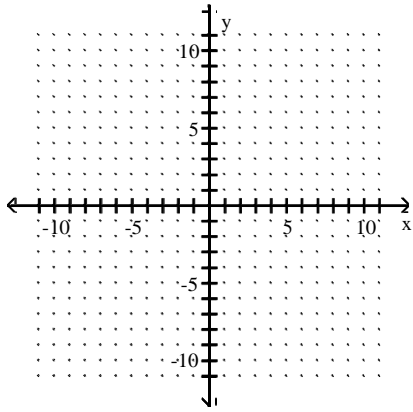

A) $(0, 1); (3, 0)$

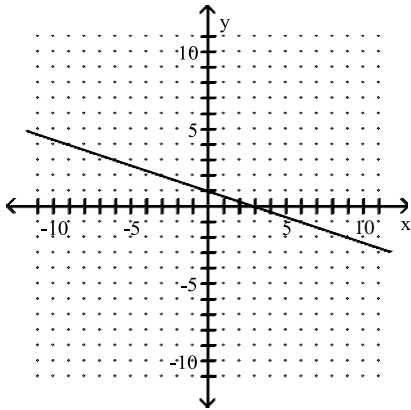

B) $(0, -1); (-3, 0)$

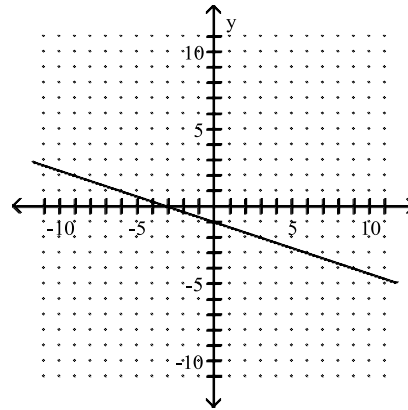

C) $(0, -1); (3, 0)$

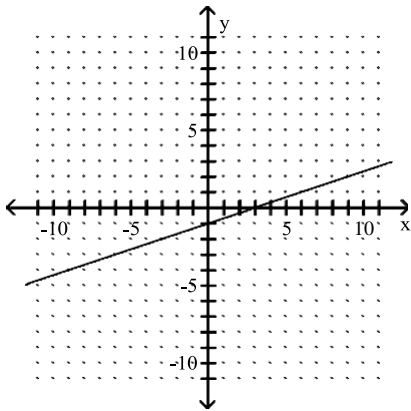

D) $(0, 1); (-3, 0)$

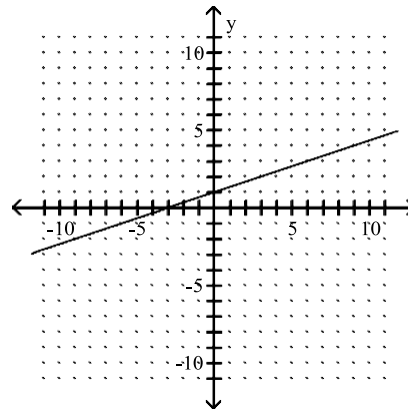

143) $3x - 9y = 0$

143) _____

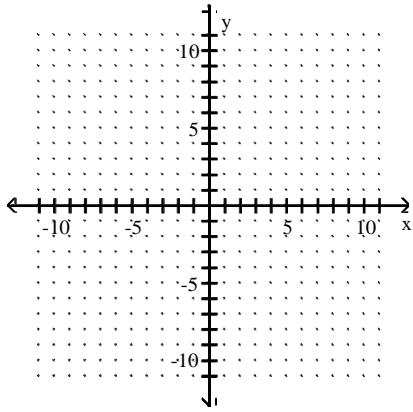

A) $(0, 0); (0, 0)$

B) $(0, 0); (0, 0)$

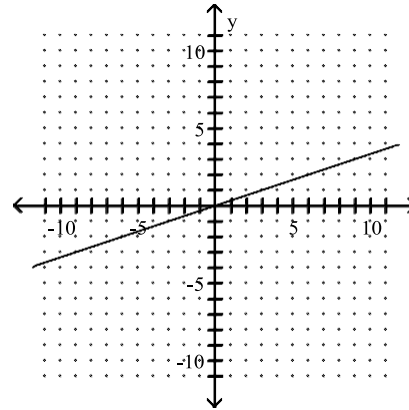
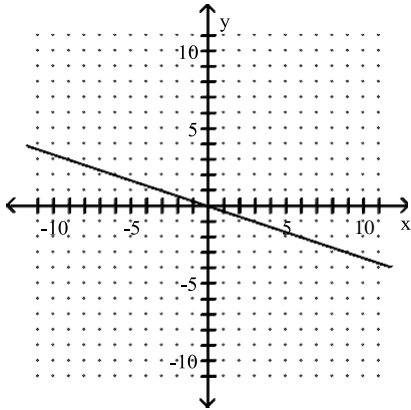

C) $(0, 0); (0, 0)$

D) $(0, 0); (0, 0)$

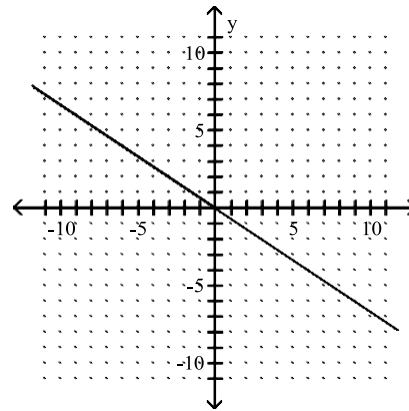
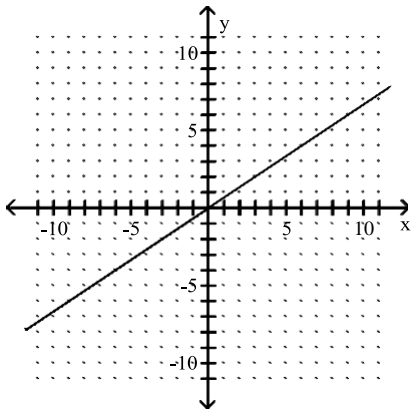

144) $7x - 4 = y$

144) _____

143) $3x - 9y = 0$

143) _____

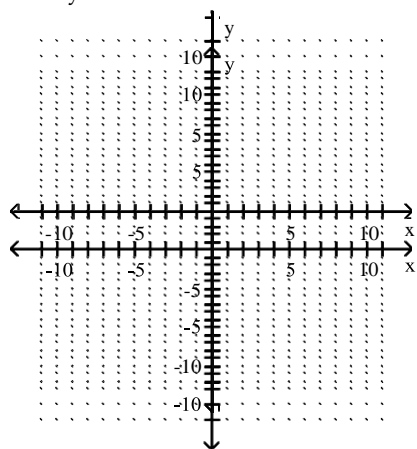

A) $(0, -4); (-\frac{4}{7}, 0)$

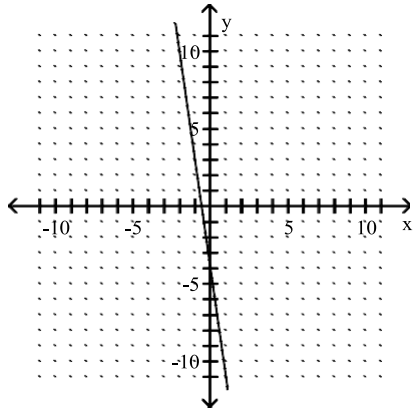

B) $(0, -4); (\frac{4}{7}, 0)$

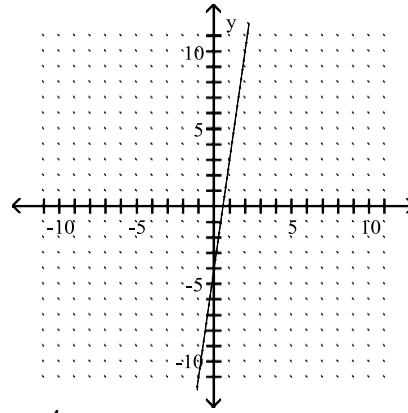

C) $(0, -\frac{4}{7}); (-4, 0)$

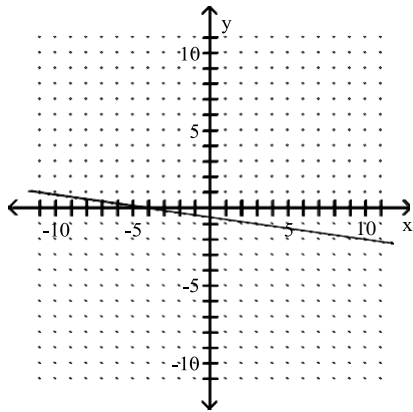

D) $(0, \frac{4}{7}); (-4, 0)$

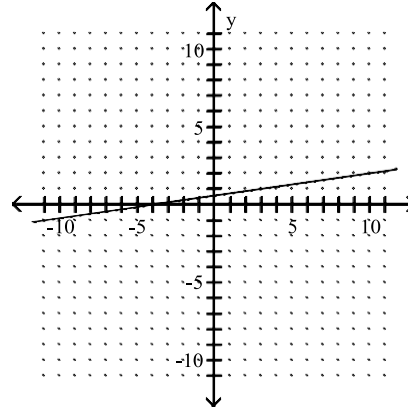

145) $f(x) = -8 - 7x$

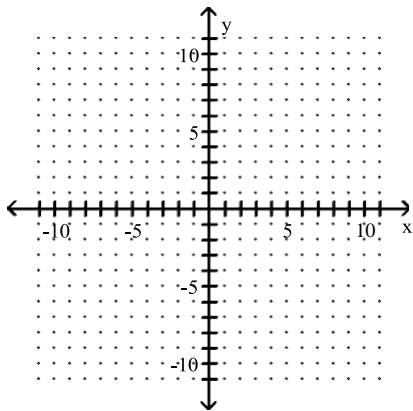

145) _____

A) $(0, -\frac{8}{7}); (-8, 0)$

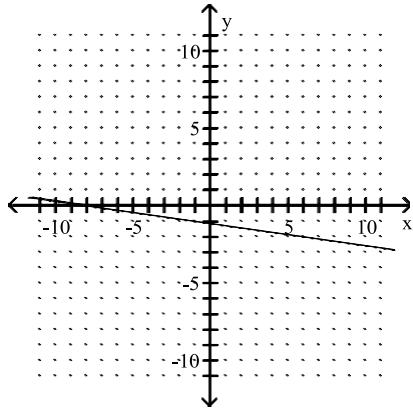

B) $(0, -8); (\frac{8}{7}, 0)$

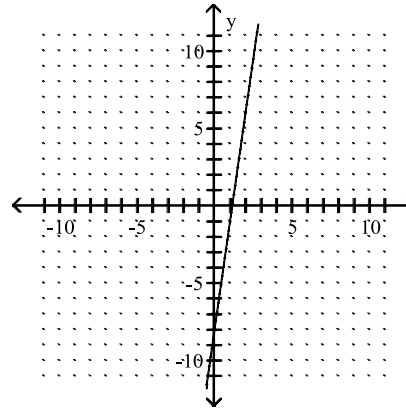

C) $(0, \frac{8}{7}); (-8, 0)$

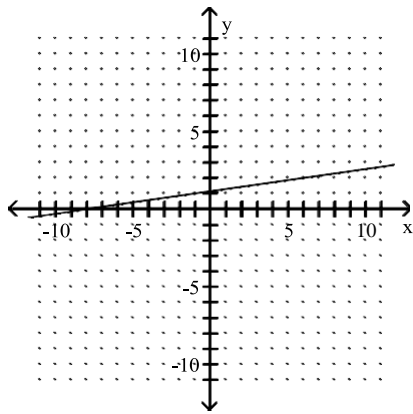

D) $(0, -8); (-\frac{8}{7}, 0)$

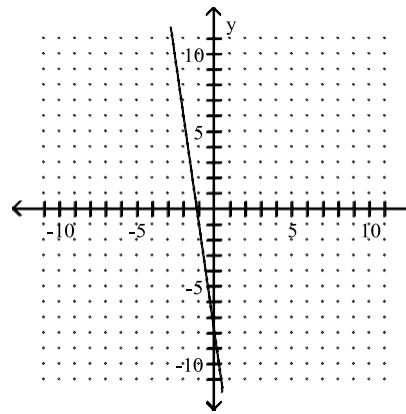

146) $3y = -6 + 2x$

146) _____

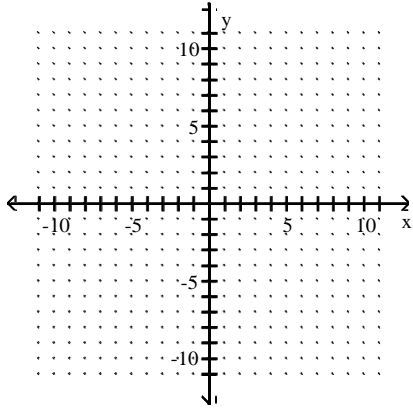

A) $(0, -2); (3, 0)$

B) $(0, 2); (3, 0)$

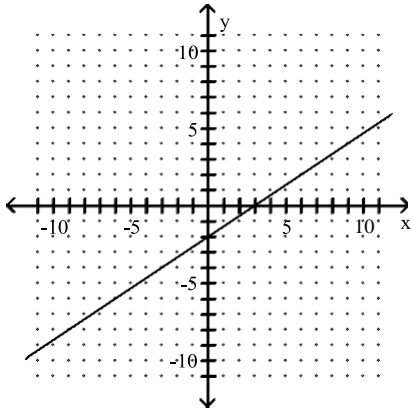

C) $(0, 3); (2, 0)$

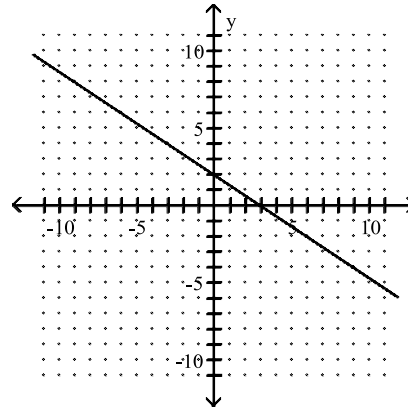

D) $(0, 3); (-2, 0)$

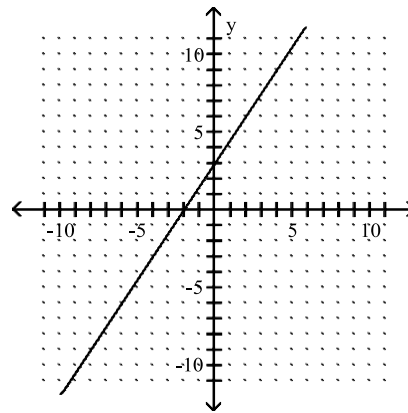
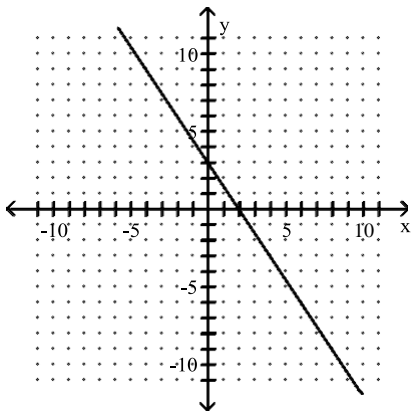

147) $2.4y - 2.7x = 19.44$

147) _____

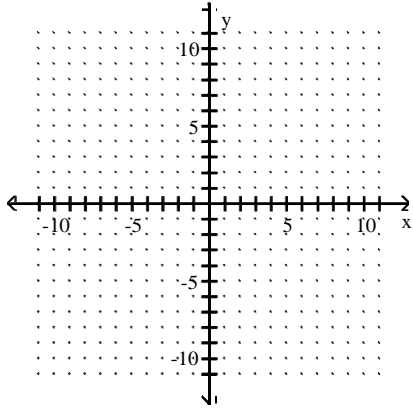

A) $(0, -8.1); (-7.2, 0)$

B) $(0, 7.2); (8.1, 0)$

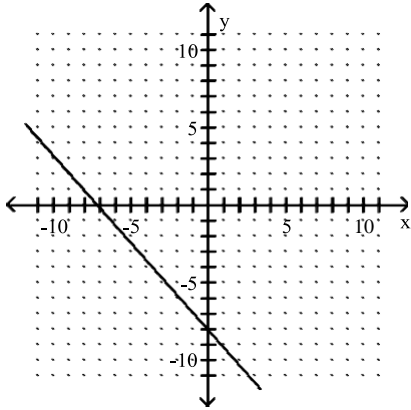

C) $(0, -7.2); (8.1, 0)$

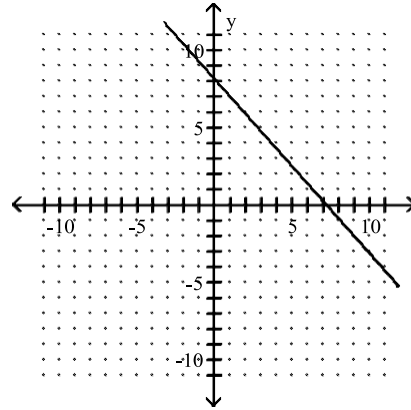

D) $(0, 8.1); (-7.2, 0)$

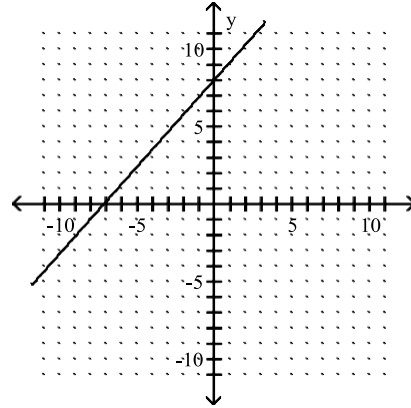
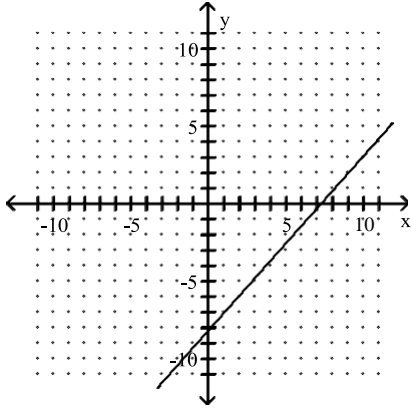

Graph using the slope and the y-intercept.

148) $y = \frac{3}{4}x - 4$

148) _____

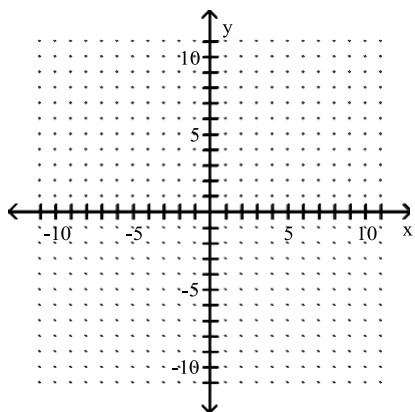

A)

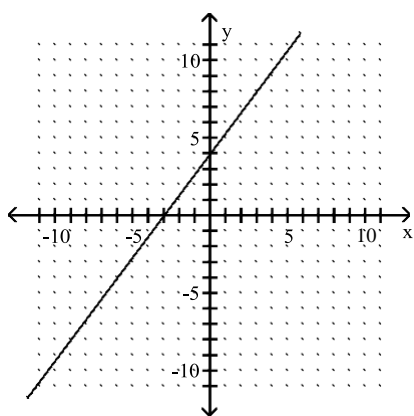

C)

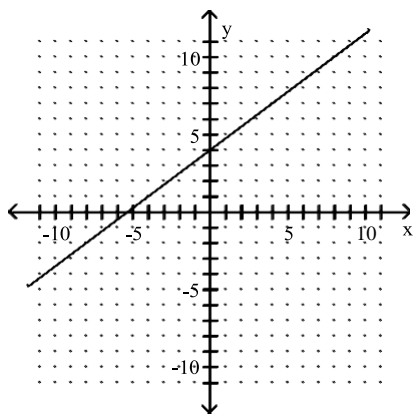

B)

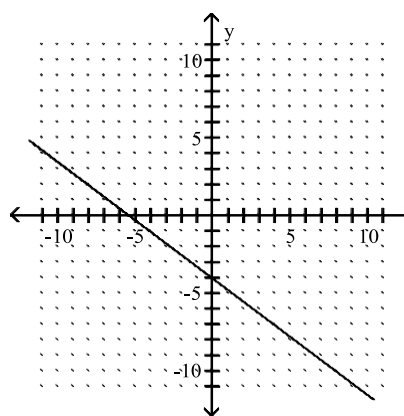

D)

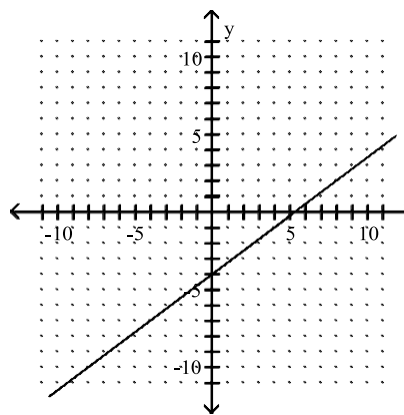

149) $f(x) = -\frac{1}{2}x + 3$

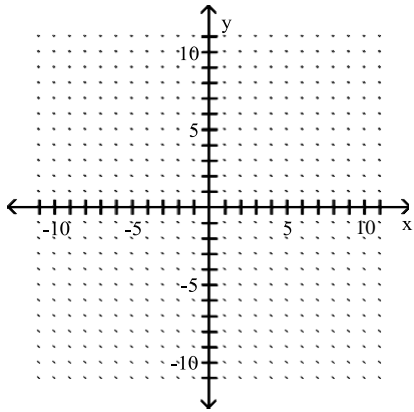

A)

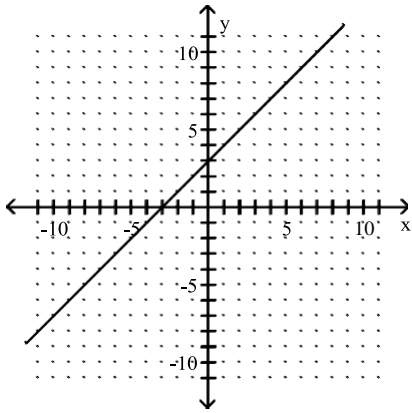

B)

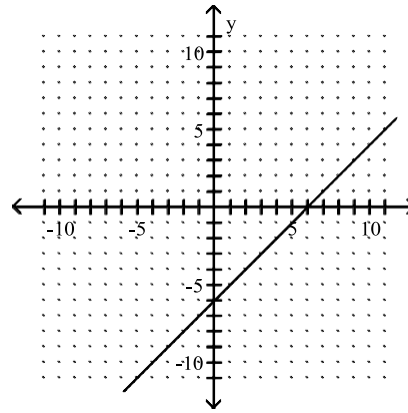

C)

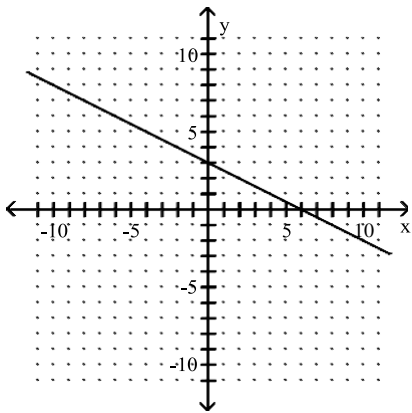

D)

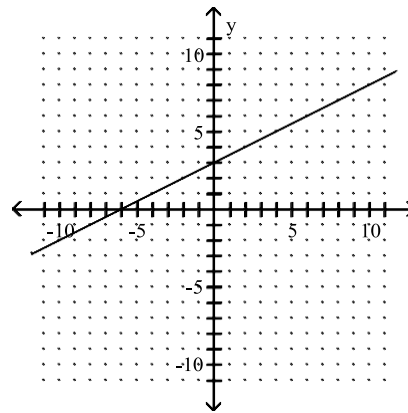

150) $x - 2y = 4$

150) _____

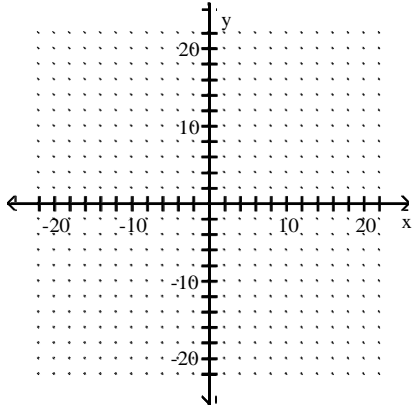

A)

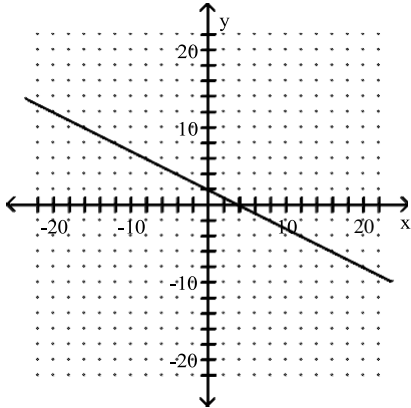

B)

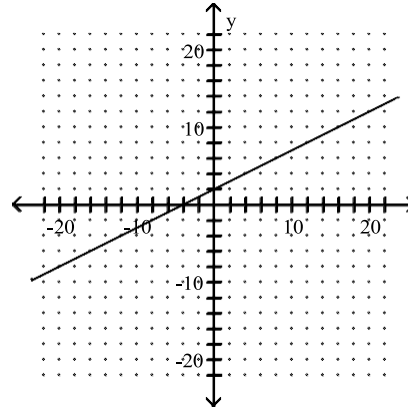

C)

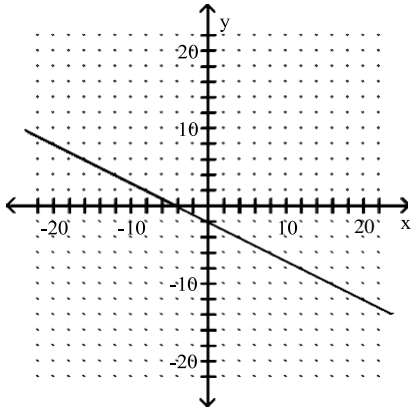

D)

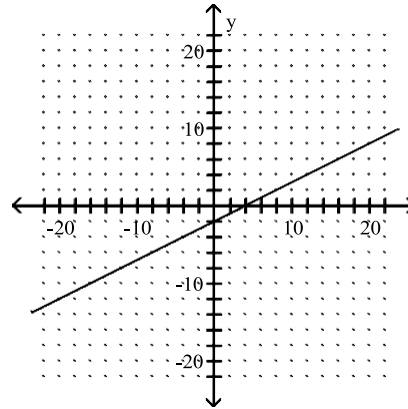

151) $7x + 2y = 14$

151) _____

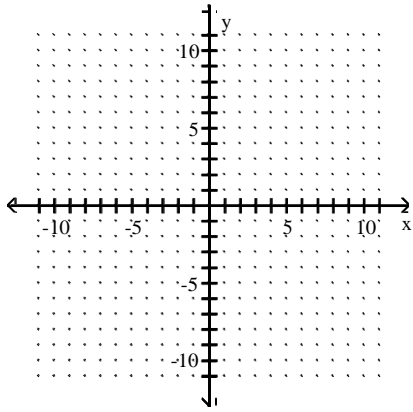

A)

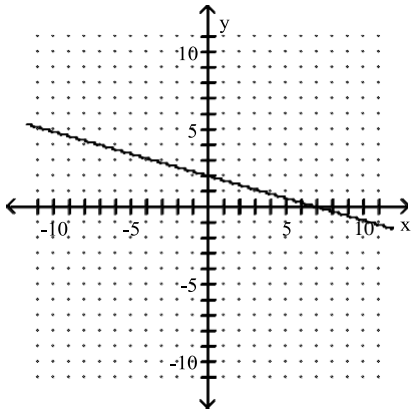

C)

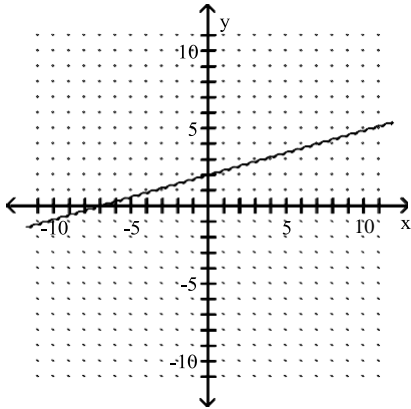

B)

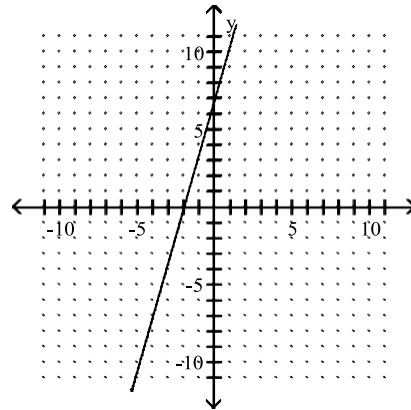

D)

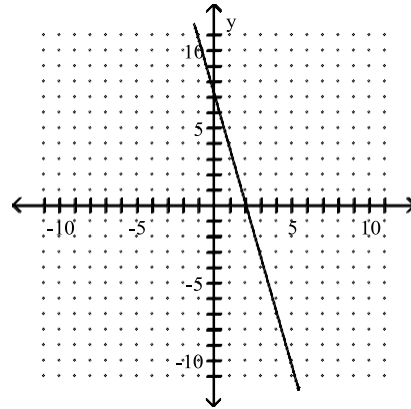

152) $4x - 12y = 24$

152) _____

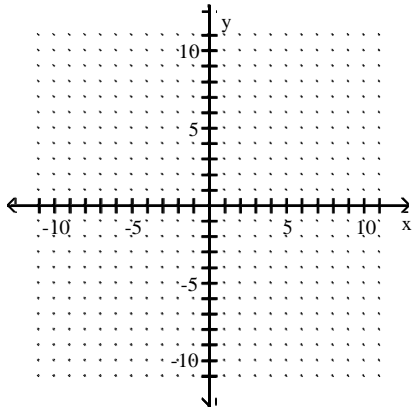

A)

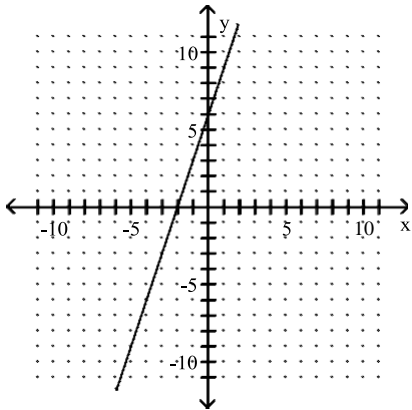

B)

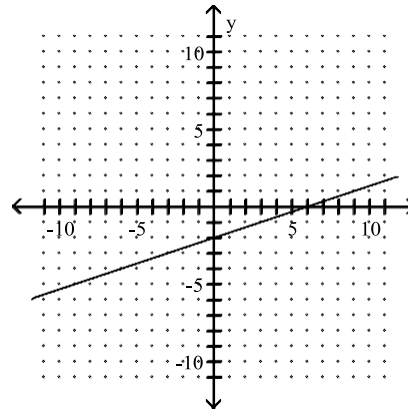

C)

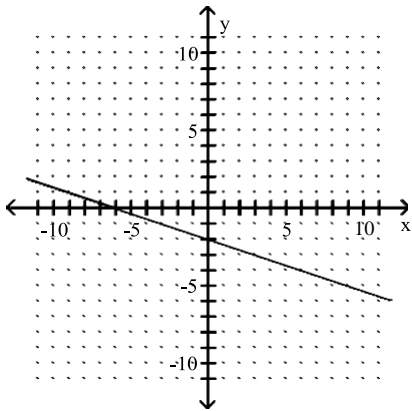

D)

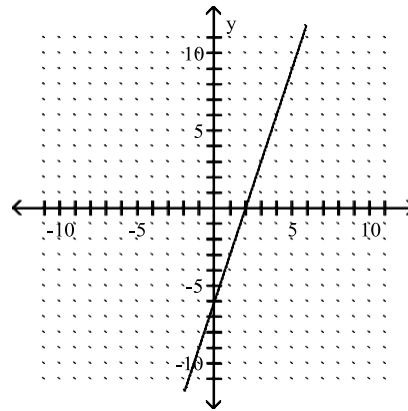

153) $-4x + 12y = -28$

153) _____

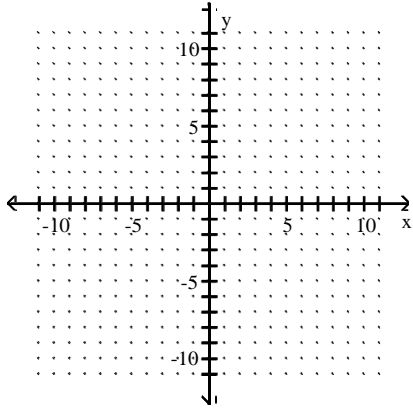

A)

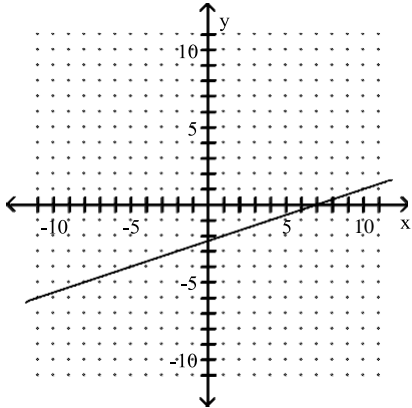

C)

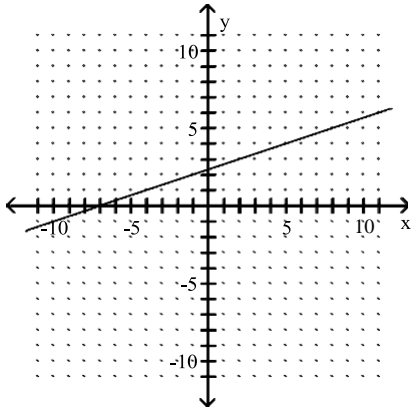

B)

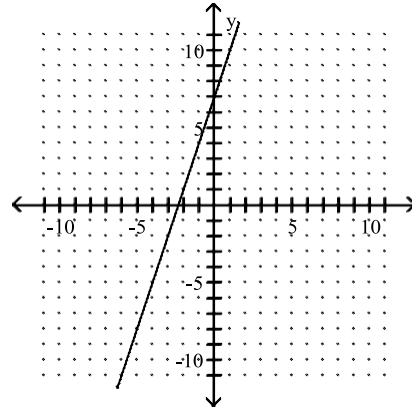

D)

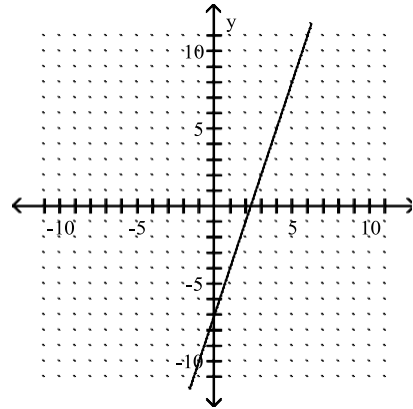

154) $g(x) = -1.6x + 3$

154) _____

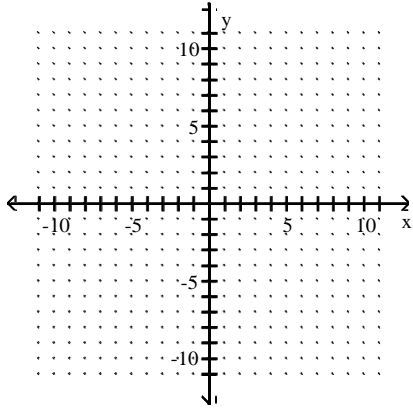

A)

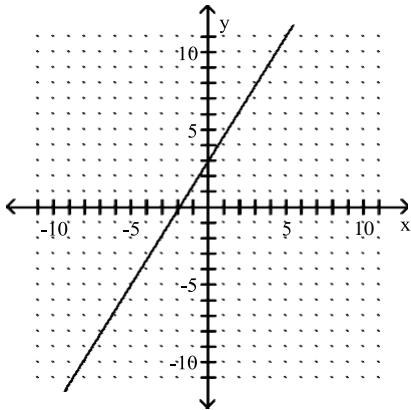

B)

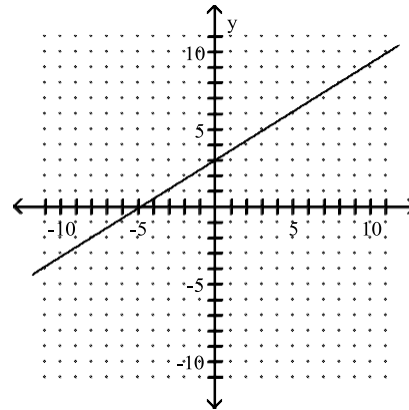

C)

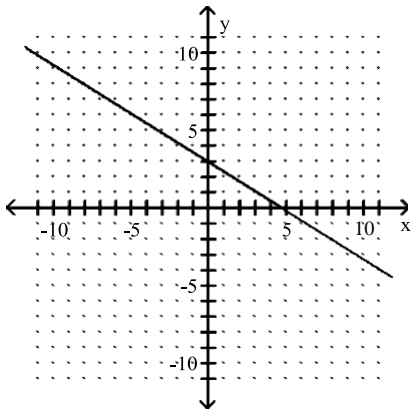

D)

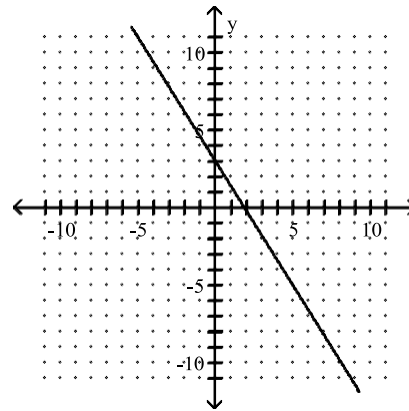

155) $9 \cdot f(x) = 6x - 21$

155) _____

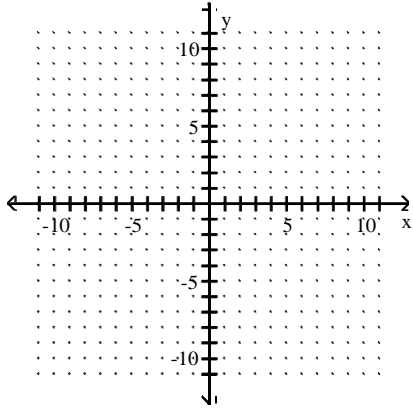

A)

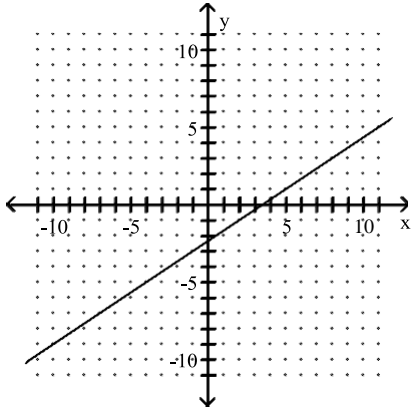

B)

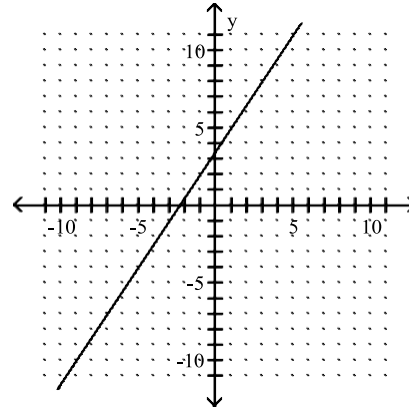

C)

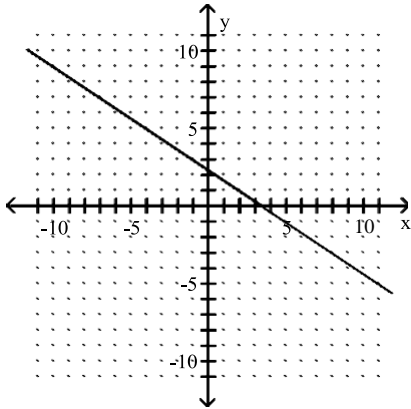

D)

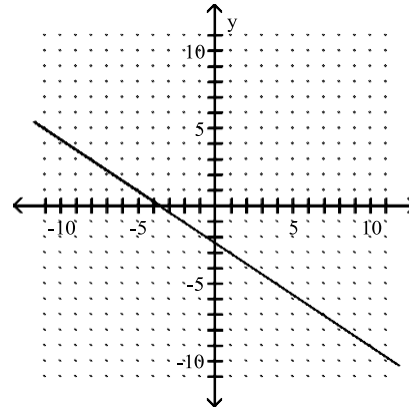

156) $-2x + 4 \cdot f(x) = -2$

156) _____

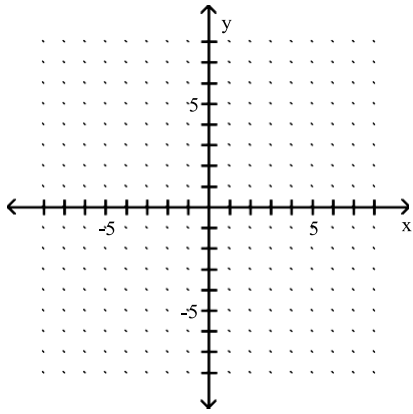

A)

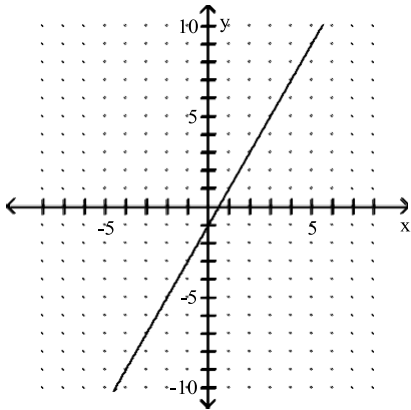

B)

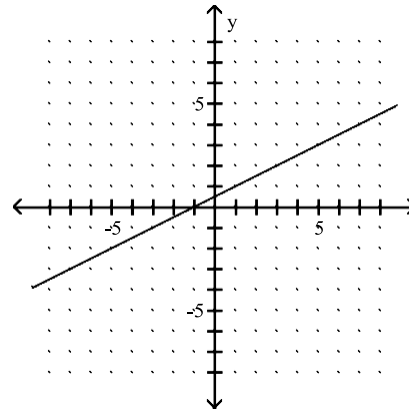

C)

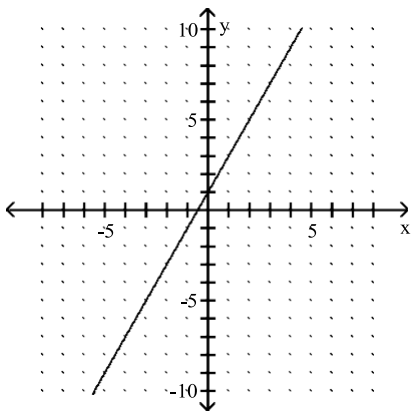

D)

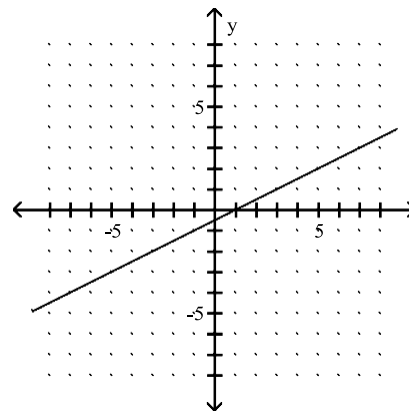

Graph.

157) $y = 3$

157) _____

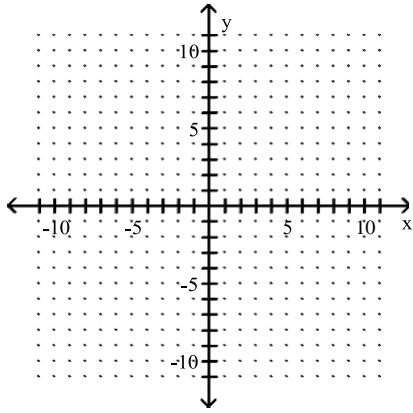

A)

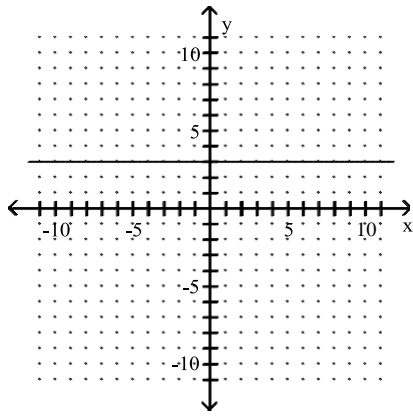

C)

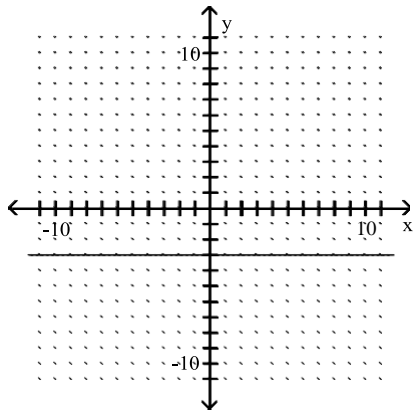

B)

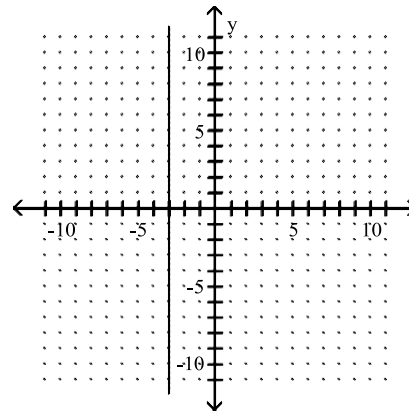

D)

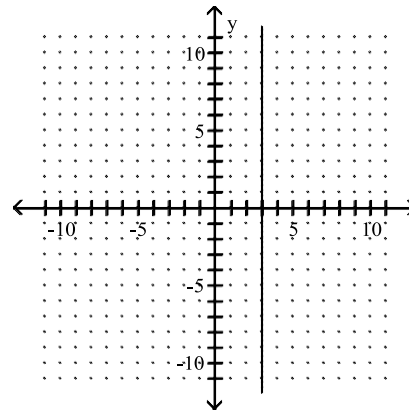

158) $x = -3$

158) _____

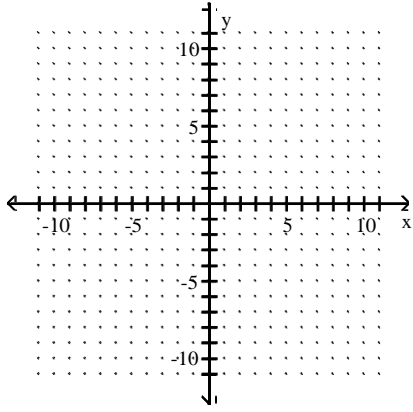

A)

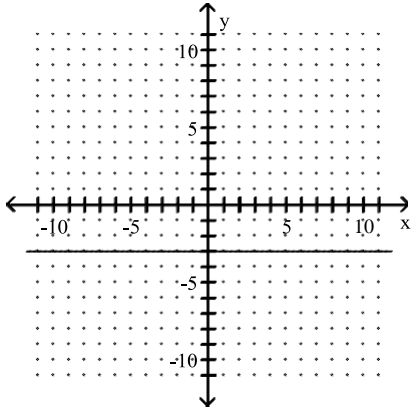

C)

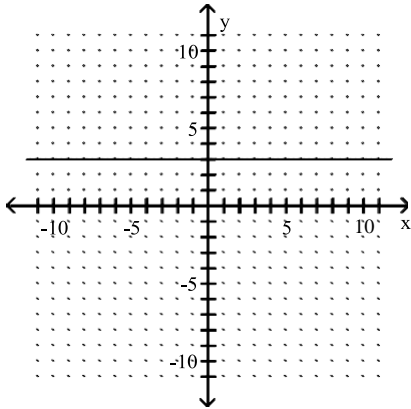

B)

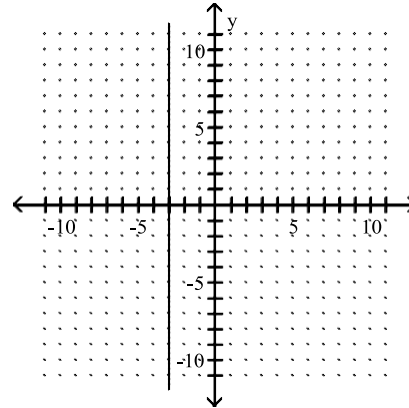

D)

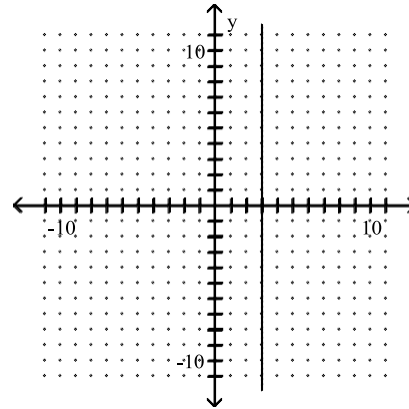

159) $y + 4 = 0$

159) _____

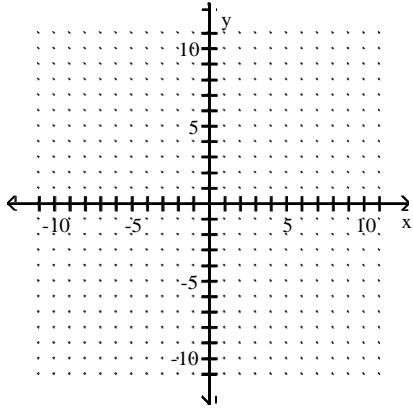

A)

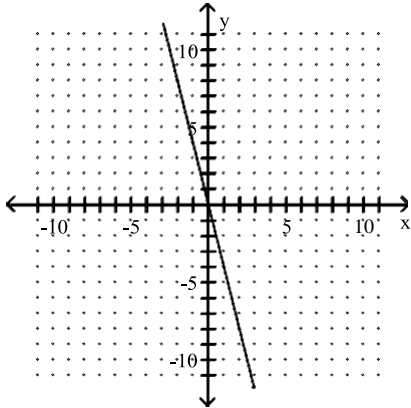

C)

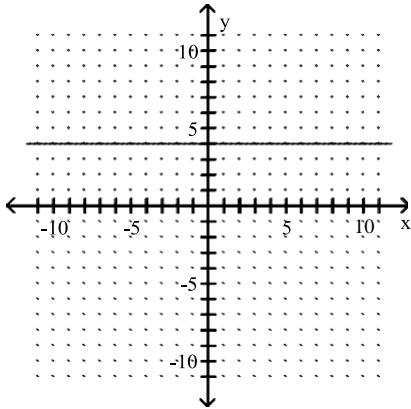

B)

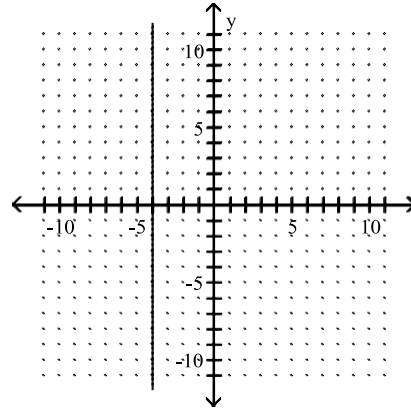

D)

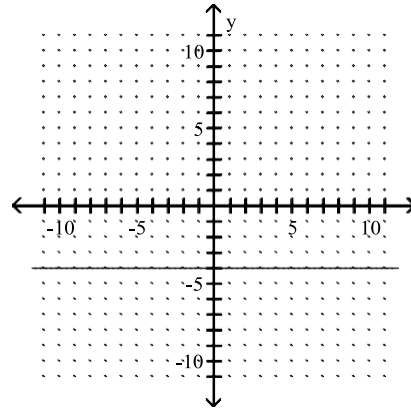

160) $9x = 27$

160) _____

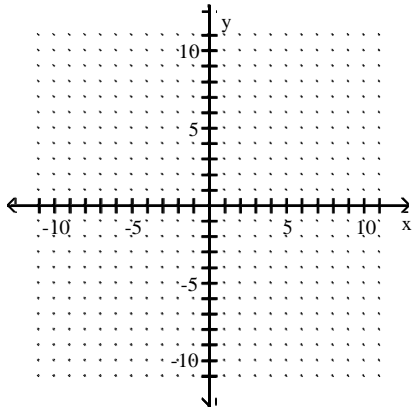

A)

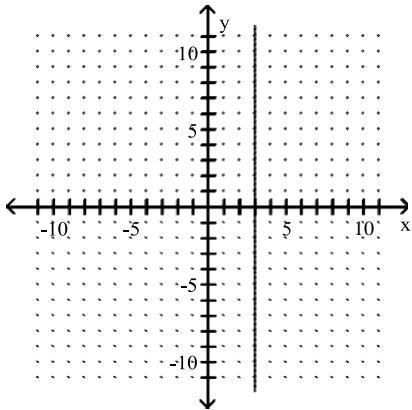

C)

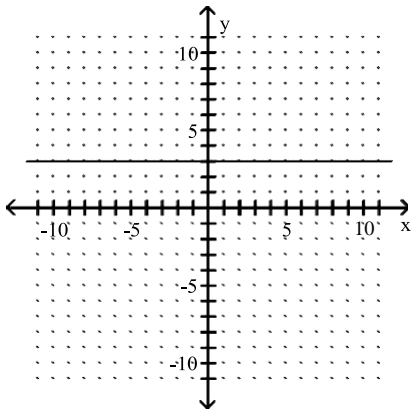

B)

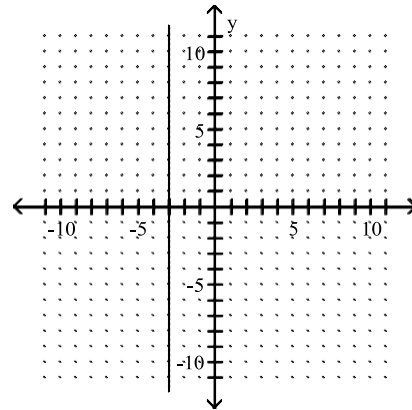

D)

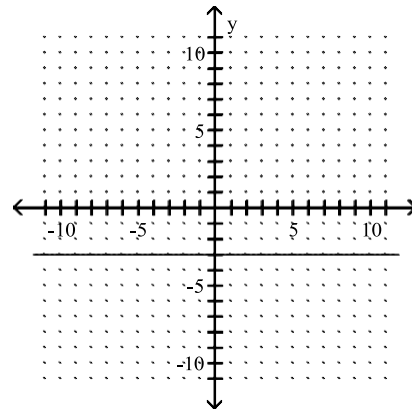

161) $2 \cdot f(x) + 3x = 2 + 3x$

161) _____

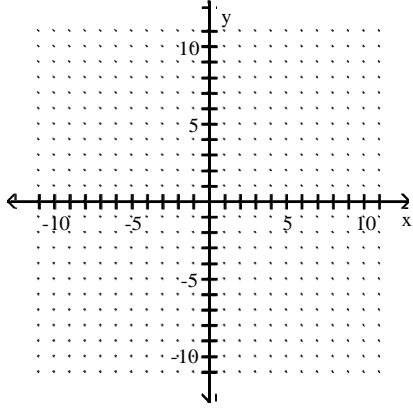

A)

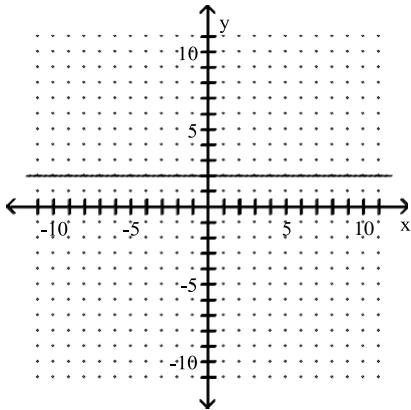

B)

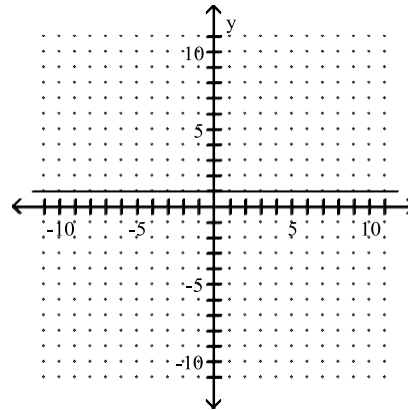

C)

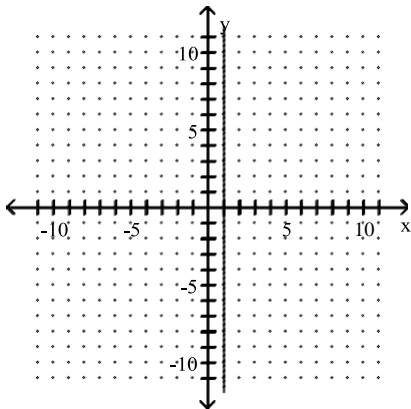

D)

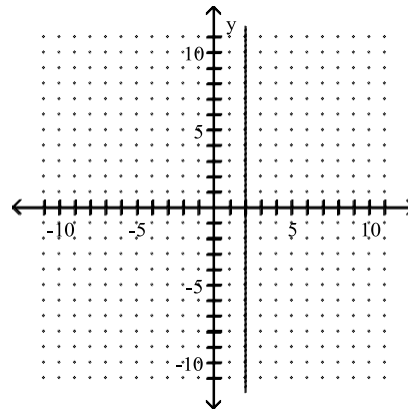

If possible, determine the slope.

162) $x = -4$

162) _____

A) -4

B) 0

C) Not defined

D) $-\frac{1}{4}$

163) $y = 2$

163) _____

A) Not defined

B) 2

C) 0

D) $\frac{1}{2}$

164) $5 \cdot f(x) - 7 = 0$ 164) _____
 A) $\frac{5}{7}$ B) Not defined C) $\frac{7}{5}$ D) 0

165) $8 + 4x = 2 + 3x$ 165) _____
 A) Not defined B) 0 C) - 6 D) 6

Tell whether the lines are "parallel", "perpendicular", or "neither."

166) $3x - 4y = 17$ 166) _____
 $8x + 6y = 17$
 A) Parallel B) Neither C) Perpendicular

167) $3x - 8y = 6$ 167) _____
 $32x + 12y = 6$
 A) Neither B) Parallel C) Perpendicular

168) $9x + 3y = 12$ 168) _____
 $18x + 6y = 26$
 A) Perpendicular B) Parallel C) Neither

169) $12x + 4y = 16$ 169) _____
 $27x + 9y = 40$
 A) Perpendicular B) Parallel C) Neither

170) $3x - 2y = -7$ 170) _____
 $3x + 3y = -7$
 A) Parallel B) Neither C) Perpendicular

171) $y + 14 = -4x$ 171) _____
 $5y = 30x - 7$
 A) Perpendicular B) Parallel C) Neither

172) $3x = -12$ 172) _____
 $9y = -12$
 A) Perpendicular B) Neither C) Parallel

Find a linear function whose graph has the given slope and y-intercept.

173) Slope $-\frac{2}{3}$, y-intercept $\left(0, \frac{14}{3}\right)$ 173) _____
 A) $f(x) = -\frac{2}{3}x - \frac{14}{3}$ B) $f(x) = -\frac{2}{3}x + \frac{14}{3}$

$$\text{C) } f(x) = -\frac{2}{3}x + \frac{14}{3}$$

$$\text{D) } f(x) = \frac{2}{3}x - \frac{14}{3}$$

174) Slope $-\frac{3}{2}$, y-intercept (0, 7)

174) _____

$$\text{A) } f(x) = -\frac{3}{2}x - 7$$

$$\text{B) } f(x) = \frac{3}{2}x + 7$$

$$\text{C) } f(x) = -\frac{3}{2}x + 7$$

$$\text{D) } f(x) = \frac{3}{2}x - 7$$

175) Slope $\frac{3}{2}$, y-intercept (0, 2)

A) $f(x) = \frac{3}{2}x - 2$

B) $f(x) = -\frac{3}{2}x + 2$

C) $f(x) = \frac{3}{2}x + 2$

D) $f(x) = -\frac{3}{2}x - 2$

175) _____

176) Slope $\frac{2}{3}$, y-intercept (0, 1)

A) $f(x) = \frac{2}{3}x - 1$

B) $f(x) = \frac{2}{3}x + 1$

C) $f(x) = -\frac{2}{3}x - 1$

D) $f(x) = -\frac{2}{3}x + 1$

176) _____

177) Slope $-\frac{5}{6}$, y-intercept $\frac{15}{2}$

A) $f(x) = -\frac{5}{6}x - \frac{15}{2}$

B) $f(x) = \frac{5}{6}x + \frac{15}{2}$

C) $f(x) = -\frac{5}{6}x + \frac{15}{2}$

D) $f(x) = \frac{5}{6}x - \frac{15}{2}$

177) _____

178) Slope $-\frac{2}{3}$, y-intercept $\frac{8}{3}$

A) $f(x) = -\frac{2}{3}x + \frac{8}{3}$

B) $f(x) = -\frac{2}{3}x - \frac{8}{3}$

C) $f(x) = \frac{2}{3}x + \frac{8}{3}$

D) $f(x) = \frac{2}{3}x - \frac{8}{3}$

178) _____

179) Slope $-\frac{3}{7}$, y-intercept 2

A) $f(x) = \frac{3}{7}x + 2$

B) $f(x) = -\frac{3}{7}x - 2$

C) $f(x) = \frac{3}{7}x - 2$

D) $f(x) = -\frac{3}{7}x + 2$

179) _____

180) Slope $-\frac{8}{9}$, y-intercept 5

A) $f(x) = \frac{8}{9}x + 5$

B) $f(x) = -\frac{8}{9}x + 5$

C) $f(x) = \frac{8}{9}x - 5$

D) $f(x) = -\frac{8}{9}x - 5$

180) _____

181) Slope 2, y-intercept (0, -8)

A) $f(x) = 2x + 8$

B) $f(x) = -8x - 2$

C) $f(x) = 2x - 8$

D) $f(x) = 2x + 2$

181) _____

182) Slope -8, y-intercept $\left(0, -\frac{4}{7}\right)$

A) $f(x) = -\frac{4}{7}x - 8$

B) $f(x) = -\frac{4}{7}x + 8$

C) $f(x) = -8x + \frac{4}{7}$

D) $f(x) = -8x - \frac{4}{7}$

182) _____

Find an equation of the line having the specified slope and containing the indicated point. Write your answer in slope-intercept form.

183) $m = -4; (7, -3)$

A) $y = 4x + 24$

B) $y = -4x + 26$

C) $y = -4x + 23$

D) $y = -4x + 25$

183) _____

- 184) $m = -4; (-9, 6)$ 184) _____
 A) $y = -4x - 31$ B) $y = -4x - 31$ C) $y = -4x - 30$ D) $y = 4x - 32$
- 185) $m = 7; (0, 7)$ 185) _____
 A) $y = 7x + 12$ B) $y = -7x + 5$ C) $y = 7x + 14$ D) $y = 7x + 7$
- 186) $m = 4; (0, -8)$ 186) _____
 A) $y = 4x + 8$ B) $y = 4x + 10$ C) $y = -4x - 6$ D) $y = 4x - 8$
- 187) $m = 5; (-8, 0)$ 187) _____
 A) $y = 5x + 40$ B) $y = -5x + 36$ C) $y = 5x - 41$ D) $y = 5x - 43$
- 188) $m = 1.1; (9, -2)$ 188) _____
 A) $y = 1.1x + 11.9$ B) $y = 1.1x - 7.9$ C) $y = 1.1x + 7.9$ D) $y = 1.1x - 11.9$
- 189) $m = -\frac{1}{3}; (10, -3)$ 189) _____
 A) $y = \frac{1}{3}x - \frac{1}{3}$ B) $y = -\frac{1}{3}x + \frac{19}{3}$ C) $y = -\frac{1}{3}x + \frac{1}{3}$ D) $y = -\frac{1}{3}x + \frac{7}{3}$
- 190) $m = -5; (0, 8.1)$ 190) _____
 A) $y = 8.1x - 5$ B) $y = -5x - 8.1$ C) $y = -5x + 8.1$ D) $y = 8.1x + 5$

Find an equation of the line containing the given pair of points

- 191) $(-3, 2)$ and $(-6, -4)$ 191) _____
 A) $y = 2x + 8$ B) $y = -2x + 8$ C) $y = 8x - 2$ D) $y = 8x + 2$
- 192) $(9, -44)$ and $(8, -39)$ 192) _____
 A) $y = -\frac{1}{5}x - \frac{211}{5}$ B) $y = \frac{1}{5}x - \frac{229}{5}$ C) $y = -5x + 1$ D) $y = 5x - 89$
- 193) $(7, -7)$ and $(-3, 3)$ 193) _____
 A) $y = -x - 7$ B) $y = -x$ C) $y = x$ D) $y = -\frac{3}{7}x$
- 194) $(0, 0)$ and $(\frac{2}{7}, -7)$ 194) _____
 A) $y = -\frac{7}{2}x - 7$ B) $y = -\frac{2}{7}x$ C) $y = -\frac{7}{2}x$ D) $y = \frac{7}{2}x$
- 195) $(6, 0)$ and $(\frac{0}{7}, -7)$ 195) _____
 A) $y = -\frac{6}{7}x + 6$ B) $y = \frac{6}{7}x - 7$ C) $y = -\frac{7}{6}x - 7$ D) $y = \frac{7}{6}x - 7$

196) (8, 0) and $(\frac{-9}{5}, 5)$
A) $y = \frac{\quad}{17}x + \frac{40}{17}$

B) $y = \frac{8}{17}x + \frac{40}{17}$

C) $y = -\frac{8}{17}x + \frac{40}{17}$

D) $y = -\frac{5}{17}x + \frac{40}{17}$

196) _____

197) $(-9, 0)$ and $(-5, 4)$ 197) _____

A) $y = \frac{\quad}{4}x + \frac{\quad}{4}$ B) $y = \frac{5}{4}x + \frac{45}{4}$ C) $y = -\frac{5}{4}x + \frac{45}{4}$ D) $y = -\frac{9}{4}x + \frac{45}{4}$

198) $\left(1, \frac{7}{10}\right)$ and $\left(\frac{5}{2}, \frac{3}{2}\right)$ 198) _____

A) $y = \frac{1}{5}x + \frac{1}{2}$ B) $y = \frac{1}{5}x + \frac{43}{50}$ C) $y = 5x - \frac{43}{10}$ D) $y = 5x - \frac{5}{2}$

199) $\left(\frac{1}{5}, \frac{3}{5}\right)$ and $\left(-\frac{1}{10}, \frac{1}{10}\right)$ 199) _____

A) $y = -\frac{5}{3}x$ B) $y = \frac{5}{3}x - \frac{2}{15}$ C) $y = \frac{5}{3}x$ D) $y = \frac{5}{3}x + \frac{4}{15}$

Write an equation of the line described.

200) Through $(-7, -2)$, parallel to $-3x + 8y = -19$ 200) _____

A) $y = -\frac{3}{8}x - \frac{5}{8}$ B) $y = \frac{3}{8}x + \frac{5}{8}$ C) $y = \frac{8}{3}x + \frac{2}{3}$ D) $y = -\frac{19}{8}x - \frac{19}{8}$

201) Through $(-7, -4)$, parallel to $5x + 7y = -49$ 201) _____

A) $y = -\frac{7}{5}x - \frac{4}{5}$ B) $y = -7x - 7$ C) $y = -\frac{5}{7}x - 9$ D) $y = \frac{5}{7}x + 9$

202) Through $(-8, 1)$, perpendicular to $4x + 3y = -35$ 202) _____

A) $y = -\frac{3}{4}x + 7$ B) $y = \frac{4}{3}x + \frac{4}{3}$ C) $y = -\frac{8}{3}x + \frac{35}{3}$ D) $y = \frac{3}{4}x + 7$

203) Through $(4, -3)$, perpendicular to $-5x + 9y = -56$ 203) _____

A) $y = \frac{9}{5}x - \frac{21}{5}$ B) $y = -\frac{5}{9}x - \frac{7}{3}$ C) $y = \frac{9}{5}x + \frac{56}{5}$ D) $y = -\frac{9}{5}x + \frac{21}{5}$

204) Through $(-2, 4)$, perpendicular to $x = -8$ 204) _____

A) $y = -2$ B) $y = -4$ C) $y = -2x + 4$ D) $y = 4$

Solve the problem.

205) A gas station sells 4820 gallons of regular unleaded gasoline on a day when they charge \$1.35 per gallon, whereas they sell 3850 gallons on a day that they charge \$1.40 per gallon. Find a linear

fun
ctio
n
tha

t expresses gallons sold as a function of price.

A) $G(p) = -19,400p + 31,010$

C) $G(p) = -19,400p + 30,988.2$

B) $G(p) = -19,400p + 30,993.8$

D) $G(p) = -19,400p + 31,026$

205) _____

206) A gas station sells 4820 gallons of regular unleaded gasoline in a day when they charge \$1.35 per gallon, whereas they sell 3992 gallons on a day that they charge \$1.40 per gallon. Find a linear function that expresses gallons sold as a function of price. Use this function to predict the number of gallons sold at a price of \$1.29 per gallon.

206) _____

A) 5822.6 gallons

B) 5817.7 gallons

C) 5810.3 gallons

D) 5813.6 gallons

- 207) Persons taking a 30-hour review course to prepare for a standardized exam average a score of 620 on that exam. Persons taking a 70-hour review course average a score of 800. Find a linear function $S(t)$, which fits this data, and which expresses score as a function of time. 207) _____
 A) $S(t) = 4.5t + 485$ B) $S(t) = 4.05t - 489$
 C) $S(t) = 4.05t + 489$ D) $S(t) = -4.5t + 485$
- 208) Persons taking a 30-hour review course to prepare for a standardized exam average a score of 620 on that exam. Persons taking a 70-hour review course average a score of 757. Find a linear function, $S(t)$, which fits this data, and which expresses score as a function of time. Use this function to predict an average score for persons taking a 57-hour review course. Round your answer to the tenths place. 208) _____
 A) 705.2 B) 712.5 C) 716.7 D) 726.5
- 209) In 1995 the United States recovered 23% of its municipal solid wastes through recycling, up from 17% in 1990. Let P represent the percentage recycled and t the number of years since 1990. Find a linear function $P(t)$ that fits this data. 209) _____
 A) $P(t) = 1.2t + 24$ B) $P(t) = -1.2t + 7$ C) $P(t) = 1.2t + 17$ D) $P(t) = 0.6t - 17$
- 210) In 1995 the United States recovered 21% of its municipal wastes through recycling, up from 17% in 1990. Let P represent the percentage recycled and t the number of years since 1990. Find a linear function $P(t)$ that fits this data. Use this function to predict the percentage recycled in 2007. 210) _____
 A) 32.3% B) 30.6% C) 28.7% D) 27%
- 211) The total sales made by a salesperson was \$25,000 after 3 months and \$68,000 after 23 months. Predict the total sales after 39 months. 211) _____
 A) \$102,370 B) \$102,442 C) \$102,400 D) \$102,500

SHORT ANSWER. Write the word or phrase that best completes each statement or answers the question.

Provide an appropriate response.

- 212) Without making a drawing, explain why the graph of the equation $y = x - 5$ passes through three quadrants. 212) _____
- 213) Explain in your own words why equations of the form $y = b$ have graphs that are horizontal lines. 213) _____
- 214) Why is the slope of a horizontal line zero? 214) _____
- 215) Why is the slope of a vertical line undefined? 215) _____
- 216) Explain why the order in which coordinates are subtracted to find slope does not matter as long as x -coordinates are subtracted in the same order as y -coordinates. 216) _____
- 217) If one line has a slope of -3 and another line has a slope of -6 , which line is steeper? Why? 217) _____

218) Can an equation of a vertical line be written in slope-intercept form?

218) _____

219) Can the point-slope equation be used to write an equation of a vertical line? Why or why not?

219) _____

- 220) Describe a situation in which point-slope form would be more useful. 220) _____
- 221) The total number of reported cases of AIDS in the United States has risen from 372 in 1981 to 100,000 in 1989 and 200,000 in 1992. Does a linear equation fit this data? Why or why not? 221) _____

Answer Key

Testname: UNTITLED2

1)

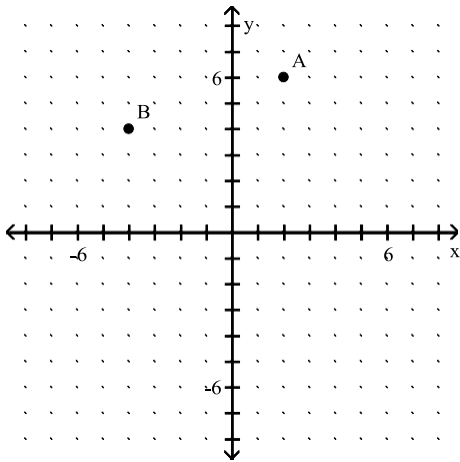

2)

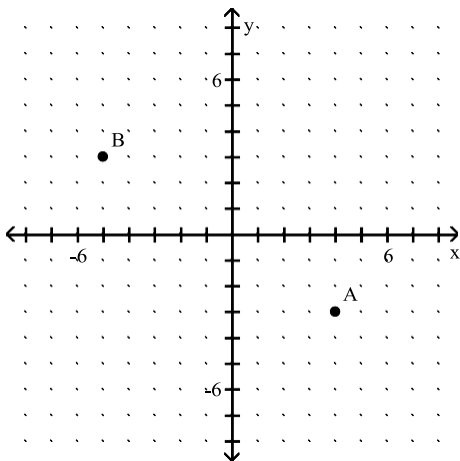

3)

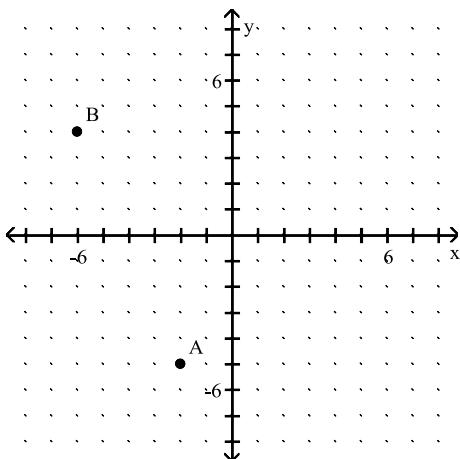

Answer Key
Testname: UNTITLED2

4)

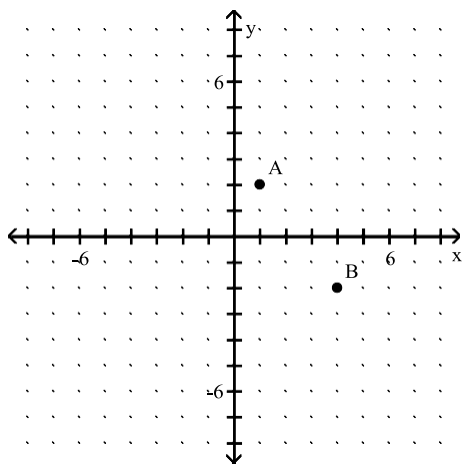

5)

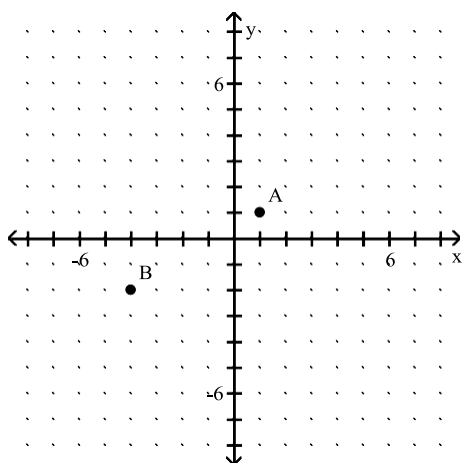

6)

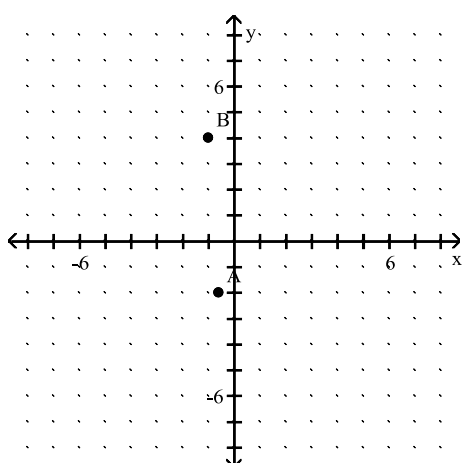

Answer Key

Testname: UNTITLED2

7)

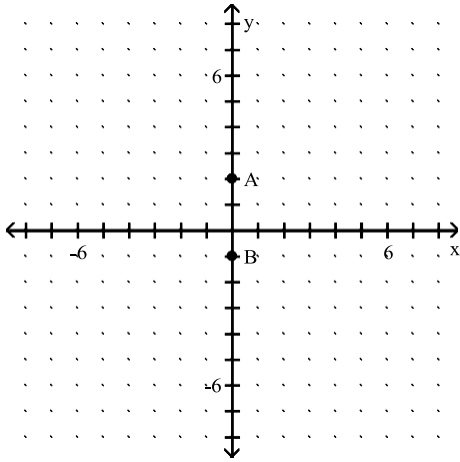

8)

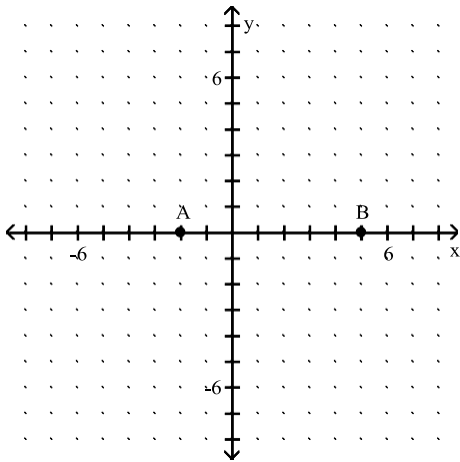

- 9) B
- 10) A
- 11) A
- 12) A
- 13) B
- 14) A
- 15) A
- 16) A
- 17) Show that (7, 4) is a solution:

$$y = x - 3$$

$$4 = ? 7 - 3$$

$$4 = ? 4 \quad \text{TRUE}$$

Show that (2, -1) is a solution:

$$y = x - 3$$

$$-1 = ? 2 - 3$$

$$-1 = ? -1 \quad \text{TRUE}$$

Coordinates of the additional solution may vary but should satisfy $y = x - 3$.

Answer Key

Testname: UNTITLED2

18) Show that (1, 4) is a solution:

$$y = x + 3$$

$$4 =? 1 + 3$$

$$4 =? 4 \quad \text{TRUE}$$

Show that (-3, 0) is a solution:

$$y = x + 3$$

$$0 =? -3 + 3$$

$$0 =? 0 \quad \text{TRUE}$$

Coordinates of the additional solution may vary but should satisfy $y = x + 3$.

19) Show that (2, 6) is a solution:

$$y = \frac{1}{2}x + 5$$

$$6 =? \frac{1}{2}(2) + 5$$

$$6 =? 1 + 5$$

$$6 =? 6 \quad \text{TRUE}$$

Show that (-4, 3) is a solution:

$$y = \frac{1}{2}x + 5$$

$$3 =? \frac{1}{2}(-4) + 5$$

$$3 =? -2 + 5$$

$$3 =? 3 \quad \text{TRUE}$$

Coordinates of the additional solution may vary but should satisfy $y = \frac{1}{2}x + 5$.

20) Show that (6, 2) is a solution:

$$y = \frac{1}{2}x - 1$$

$$2 =? \frac{1}{2}(6) - 1$$

$$2 =? 3 - 1$$

$$2 =? 2 \quad \text{TRUE}$$

Show that (0, -1) is a solution:

$$y = \frac{1}{2}x - 1$$

$$-1 =? \frac{1}{2}(0) - 1$$

$$-1 =? 0 - 1$$

$$-1 =? -1 \quad \text{TRUE}$$

Coordinates of the additional solution may vary but should satisfy $y = \frac{1}{2}x - 1$.

Answer Key

Testname: UNTITLED2

21) Show that (3, 0) is a solution:

$$2x + y = 6$$

$$2(3) + 0 =? 6$$

$$6 + 0 =? 6$$

$$6 =? 6 \quad \text{TRUE}$$

Show that (6, -6) is a solution:

$$2x + y = 6$$

$$2(6) + (-6) =? 6$$

$$12 + (-6) =? 6$$

$$6 =? 6 \quad \text{TRUE}$$

Coordinates of the additional solution may vary but should satisfy $2x + y = 6$.

22) Show that (6, 1) is a solution:

$$x + 2y = 8$$

$$6 + 2(1) =? 8$$

$$6 + 2 =? 8$$

$$8 =? 8 \quad \text{TRUE}$$

Show that (-2, 5) is a solution:

$$x + 2y = 8$$

$$-2 + 2(5) =? 8$$

$$-2 + 10 =? 8$$

$$8 =? 8 \quad \text{TRUE}$$

Coordinates of the additional solution may vary but should satisfy $x + 2y = 8$.

23) Show that (0, -3) is a solution:

$$6x - 2y = 6$$

$$6(0) - 2(-3) =? 6$$

$$0 - (-6) =? 6$$

$$6 =? 6 \quad \text{TRUE}$$

Show that (2, 3) is a solution:

$$6x - 2y = 6$$

$$6(2) - 2(3) =? 6$$

$$12 - 6 =? 6$$

$$6 =? 6 \quad \text{TRUE}$$

Coordinates of the additional solution may vary but should satisfy $6x - 2y = 6$.

24) Show that (-1, -5) is a solution:

$$3x - 3y = 12$$

$$3(-1) - 3(-5) =? 12$$

$$-3 + 15 =? 12$$

$$12 =? 12 \quad \text{TRUE}$$

Show that (2, -2) is a solution:

$$3x - 3y = 12$$

$$3(2) - 3(-2) =? 12$$

$$6 - (-6) =? 12$$

$$12 =? 12 \quad \text{TRUE}$$

Coordinates of the additional solution may vary but should satisfy $3x - 3y = 12$.

25) C

26) B

27) A

28) D

29) D

30) D

Answer Key

Testname: UNTITLED2

- 31) C
- 32) C
- 33) D
- 34) B
- 35) A
- 36) A
- 37) D
- 38) D
- 39) C
- 40) C
- 41) C
- 42) C
- 43) B
- 44) A
- 45) A
- 46) B
- 47) B
- 48) A
- 49) A
- 50) B
- 51) A
- 52) B
- 53) B
- 54) A
- 55) C
- 56) B
- 57) B
- 58) D
- 59) C
- 60) D
- 61) D
- 62) C
- 63) B
- 64) A
- 65) C
- 66) C
- 67) D
- 68) B
- 69) C
- 70) A
- 71) D
- 72) C
- 73) B
- 74) A
- 75) D
- 76) D
- 77) D
- 78) C
- 79) B
- 80) A

Answer Key

Testname: UNTITLED2

- 81) A
- 82) B
- 83) B
- 84) B
- 85) D
- 86) D
- 87) C
- 88) C
- 89) A
- 90) A
- 91) B
- 92) B
- 93) D
- 94) B
- 95) C
- 96) B
- 97) D
- 98) B
- 99) C
- 100) B
- 101) C
- 102) D
- 103) D
- 104) A
- 105) C
- 106) B
- 107) B
- 108) C
- 109) B
- 110) D
- 111) D
- 112) B
- 113) C
- 114) A
- 115) D
- 116) B
- 117) B
- 118) D
- 119) B
- 120) C
- 121) A
- 122) D
- 123) A
- 124) D
- 125) B
- 126) B
- 127) A
- 128) B
- 129) D
- 130) B

Answer Key

Testname: UNTITLED2

- 131) B
- 132) D
- 133) D
- 134) B
- 135) D
- 136) C
- 137) D
- 138) A
- 139) B
- 140) A
- 141) D
- 142) C
- 143) B
- 144) B
- 145) D
- 146) A
- 147) D
- 148) D
- 149) C
- 150) D
- 151) D
- 152) B
- 153) A
- 154) D
- 155) A
- 156) D
- 157) A
- 158) B
- 159) D
- 160) A
- 161) B
- 162) C
- 163) C
- 164) D
- 165) A
- 166) C
- 167) C
- 168) B
- 169) B
- 170) B
- 171) C
- 172) A
- 173) C
- 174) C
- 175) C
- 176) B
- 177) C
- 178) A
- 179) D
- 180) B

Answer Key

Testname: UNTITLED2

- 181) C
182) D
183) D
184) C
185) D
186) D
187) A
188) D
189) C
190) C
191) A
192) C
193) B
194) C
195) D
196) D
197) B
198) A
199) D
200) B
201) C
202) D
203) D
204) D
205) A
206) D
207) A
208) B
209) C
210) B
211) C
212) When $x < 0$, then $y < 0$ and the graph contains points in quadrant III. When $0 < x < 5$, then $y < 0$ and the graph contains points in quadrant IV. When $x > 5$, then $y > 0$ and then graph contains points in quadrant I.
213) The second coordinate of any point on the graph is b , regardless of the first coordinate, so the graph is a line parallel to the x -axis and $|b|$ units above or below it. Thus, the graph is a horizontal line
214) For any two points on the line (x_1, b) and (x_2, b) , $x_1 \neq x_2$, $m = \frac{b - b}{x_1 - x_2} = \frac{0}{x_1 - x_2} = 0$.
215) For any two points on the line (a, y_1) and (a, y_2) , $y_1 \neq y_2$, $m = \frac{y_1 - y_2}{a - a} = \frac{y_1 - y_2}{0}$.
216) $m = \frac{y_2 - y_1}{x_2 - x_1} = \frac{-1 \cdot (y_2 - y_1)}{-1 \cdot (x_2 - x_1)} = \frac{y_1 - y_2}{x_1 - x_2}$.
217) The line with a slope of -6 is steeper, because the larger the absolute value of the slope, the steeper the line.
218) No, the slope of a vertical line is undefined.
219) No; the slope of a vertical line is undefined.
220) Point-slope form would be more useful if you wanted to find an equation of a line with a specified slope passing through a specified point that is not the y -intercept.
221) No; the rate of increase is not constant. The slope of the segment from $(0, 372)$ to $(8, 100,000)$ is $12,453.5$ while the slope

Answer Key

Testname: UNTITLED2

of the segment from (8, 100,000) to (11, 200,000) is 33,333.3.