

**Test Bank for Intermediate Algebra Concepts and Applications
10th Edition Bittinger Ellenbogen Johnson 9780134497174**

Full Link Download:

Test Bank:

<https://testbankpack.com/p/test-bank-for-intermediate-algebra-concepts-and-applications-10th-edition-bittinger-ellenbogen-johnson-9780134497174/>

MULTIPLE CHOICE. Choose the one alternative that best completes the statement or answers the question.

Give the coordinates of the specified point.

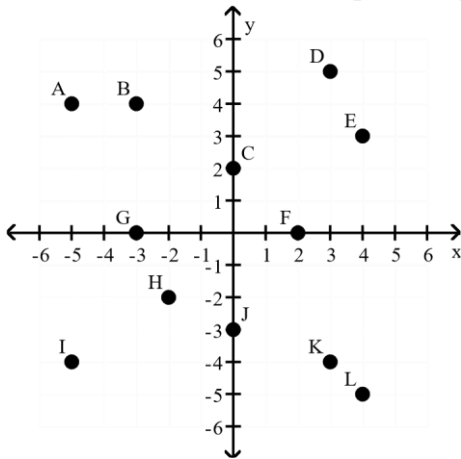

1) D

- A) (3, 3)
- B) (5, 3)
- C) (3, 5)
- D) (5, 5)

Answer: C

2)

C

- A) (0, 2)
- B) (2, 0)
- C) (0, 1)
- D) (2, 2)

Answer: A

- 3) G
A) (0, -3)
B) (3, 0)
C) (0, 3)
D) (-3, 0)

Answer: D

- 4) B
A) (-4, 3)
B) (3, -4)
C) (4, -3)
D) (-3, 4)

Answer: D

- 5) L
A) (4, -5)
B) (-5, 4)
C) (5, -4)
D) (-4, 5)

Answer: A

- 6) I
A) (-4, -5) B) (4, -5)
C) (-5, -4) D)
(-5, 4)

Answer: C

SHORT ANSWER. Write the word or phrase that best completes each statement or answers the question.

Plot the points with the given coordinates.

7) $A(5, 6), B(-3, 5)$

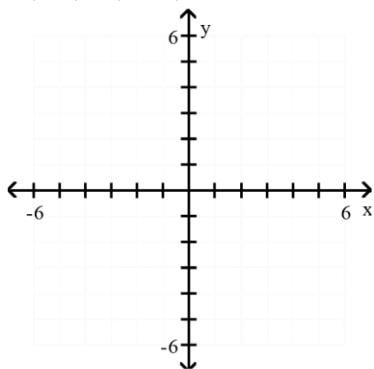

Answer:

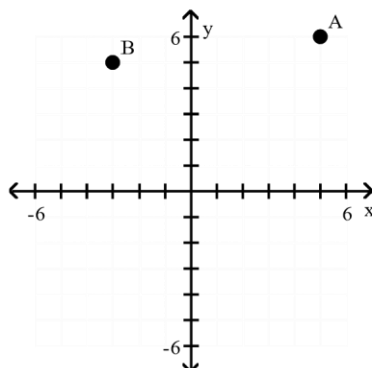

8) $A(6, -2), B(-2, 5)$

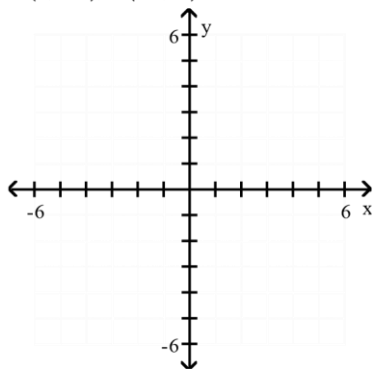

Answer:

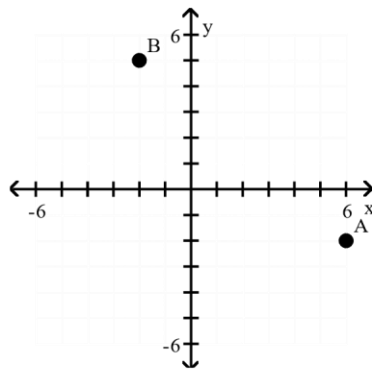

9) $A(-6, -3), B(-1, 3)$

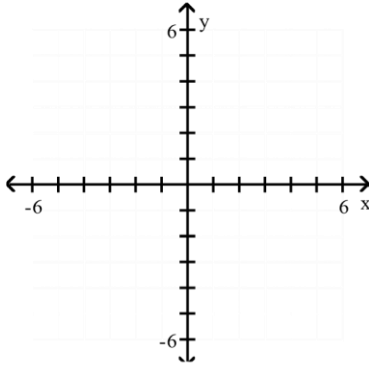

Answer:

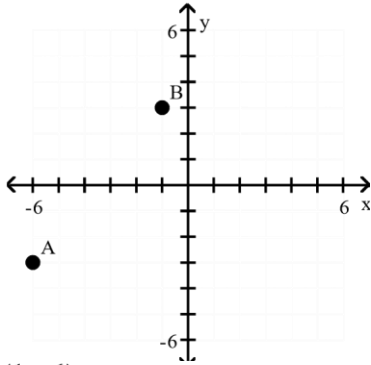

10) $A(3, 3)$, $B(1, -6)$

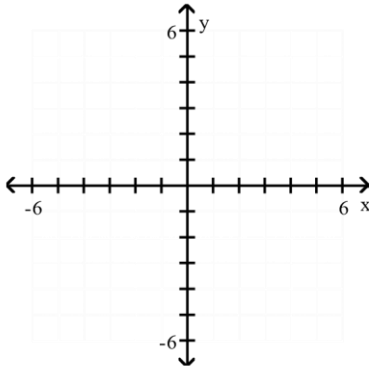

Answer:

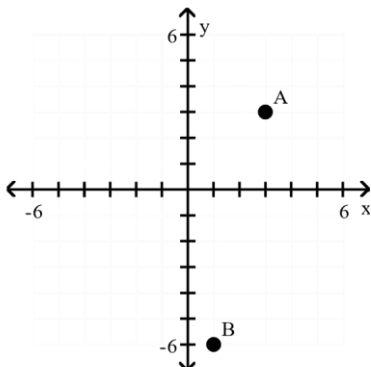

11) $A(4, 5)$, $B(-2, -6)$

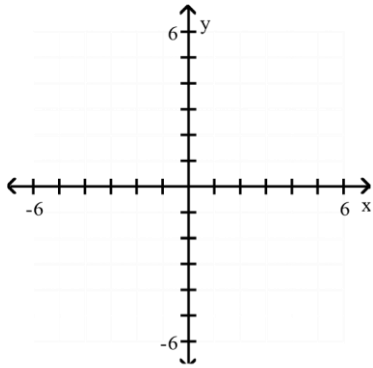

Answer:

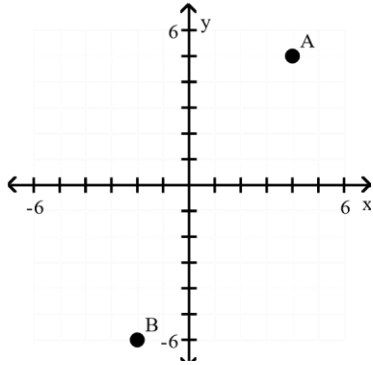

12) $A(-\frac{3}{2}, -3)$, $B(-6, 5)$

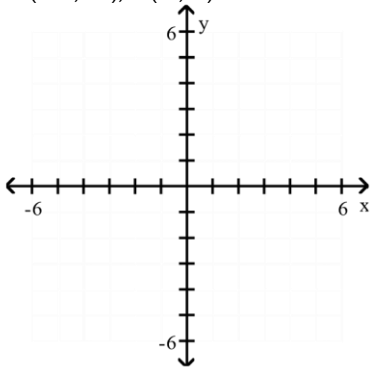

Answer:

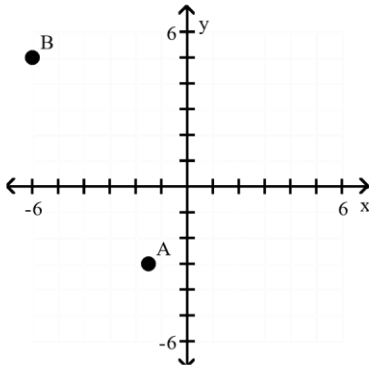

13) $A(0, -1)$, $B(0, 1)$

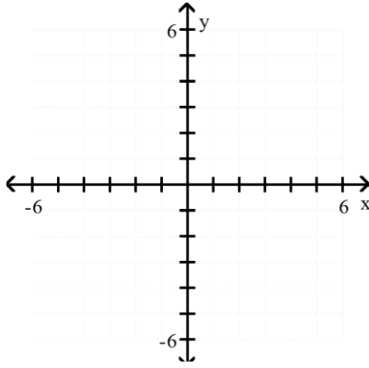

Answer:

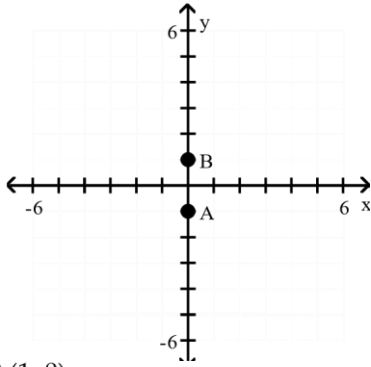

14) $A(4, 0)$, $B(1, 0)$

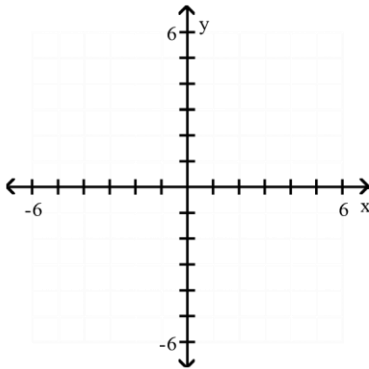

Answer:

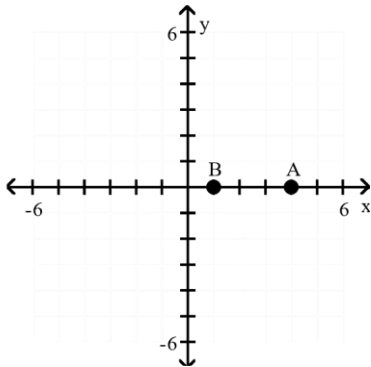

Use the ordered pairs to form the vertices of a figure. Then find the area of the figure.

- 15) $(-3, 2), (-2, 2), (-2, 3), (2, 3), (2, -5), (-3, -5)$

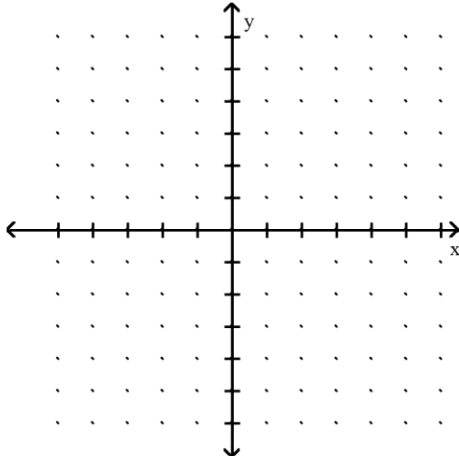

Answer:

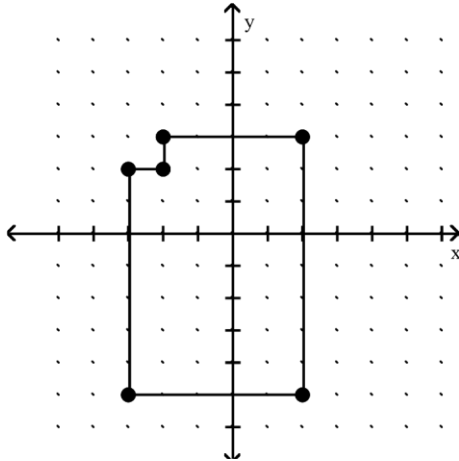

Area is 39 sq. units.

- 16) $(-4, 2), (-1, 2), (-1, 4), (1, 4), (1, 3), (5, 3), (5, -3), (-4, -3)$

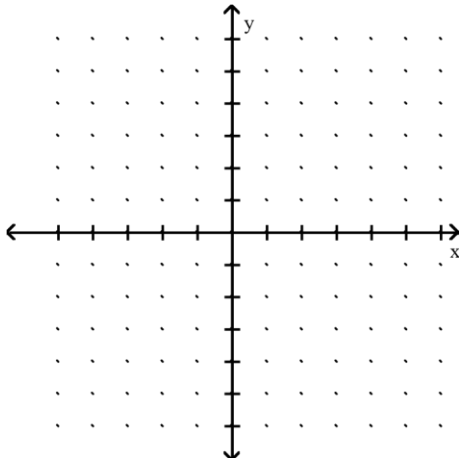

Answer:

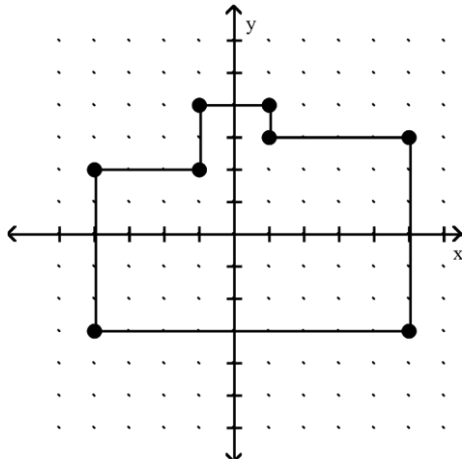

Area is 53 sq. units.

MULTIPLE CHOICE. Choose the one alternative that best completes the statement or answers the question.

Name the quadrant, if any, in which the point is located.

- 17) (6, 15)
 A) Quadrant IV
 B) Quadrant II
 C) Quadrant III
 D) Quadrant I Answer: D

- 18) (-15, 11)
 A) Quadrant II B) Quadrant IV C) Quadrant I
 D) Quadrant III

Answer: A

- 19) (-2, -14)
 A) Quadrant I
 B) Quadrant IV C) Quadrant II
 D) Quadrant III

Answer: D

- 20) (10, -14)
 A) Quadrant I
 B) Quadrant III
 C) Quadrant IV
 D) Quadrant II

Answer: C

21) $\left(\begin{array}{c} -2, -3 \\ 5, 8 \end{array} \right)$

- A) Quadrant III B) Quadrant I

- C) Quadrant II
- D) Quadrant IV

Answer: C

$$22) \left(\begin{array}{cc} -4 & -1 \\ 5 & 2 \end{array} \right)$$

- A) Quadrant I
 - B) Quadrant III
 - C) Quadrant IV
 - D) Quadrant II
- Answer: B

$$23) \left(\begin{array}{cc} 4 & -5 \\ 7 & 6 \end{array} \right)$$

- A) Quadrant I
- B) Quadrant II
- C) Quadrant IV
- D) Quadrant III

Answer: C

Determine if the ordered pair is a solution of the equation. Remember to use alphabetical order for substitution.

24) $(5, 7); x + y = 12$

- A) No
- B) Yes

Answer: B

25) $(7, 4); x - y = 49$

- A) Yes
- B) No

Answer: B

26) $(3, 5); 5x + y = 20$

- A) Yes
 - B) No
- Answer: A

27) $(4, 4); 5x + 2y = 28$

- A) Yes
- B) No

Answer: A

28) $(5, 3); 2x - 5y = 25$

A) No

B) Yes

Answer: A

29) $(4, -5); 2x + 7y = -27$

A) No

B) Yes

Answer: B

30) $\left(\begin{matrix} z \\ 8 \end{matrix} \right)_0; 2x + 8y = 10$

A) No B) Yes

Answer: A

31) $(4, 14); y = 4x - 2$

A) Yes B) No

Answer: A

32) $(-2, -3); 4w^2 - z = 19$

A) Yes B) No

Answer: A

33) $(1, 0); y = x^3 - 2$

A) Yes

B) No

Answer: B

Graph.

34) $y = x + 4$

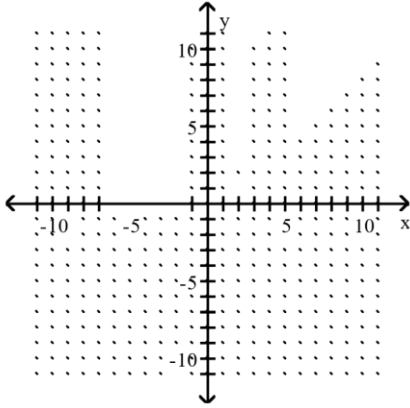

A)

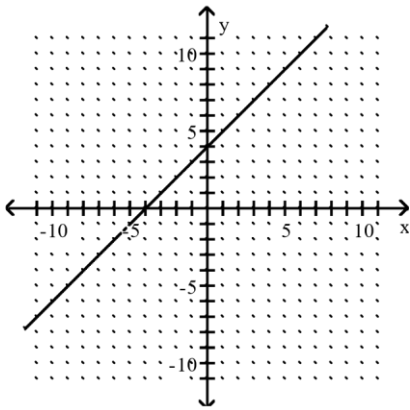

B)

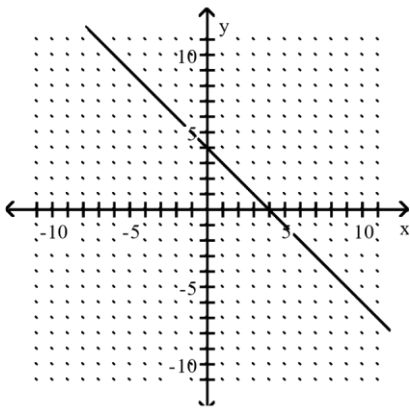

C)

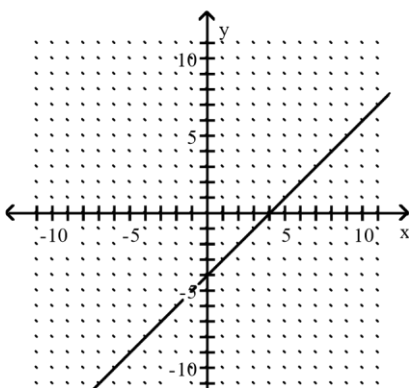

D)

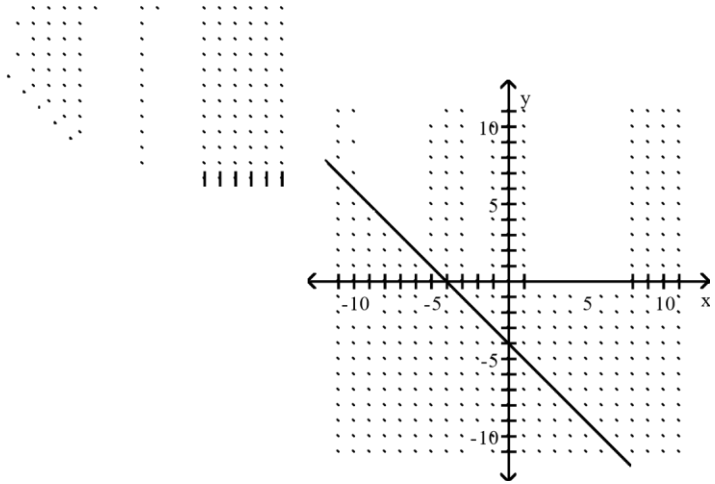

Answer: A

35) $y + 4 = x$

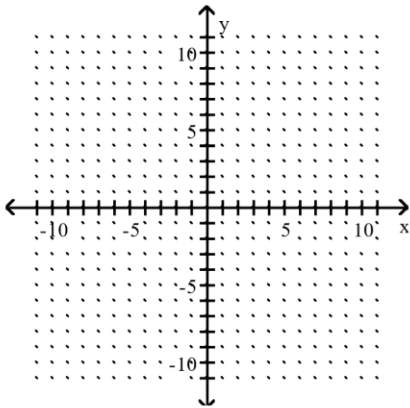

A)

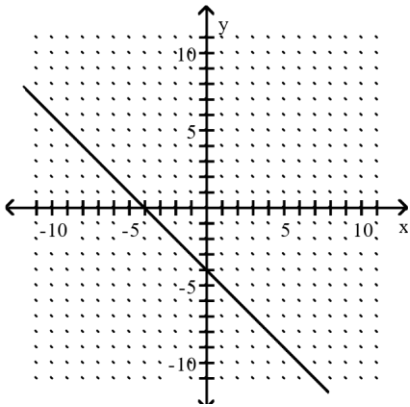

B)

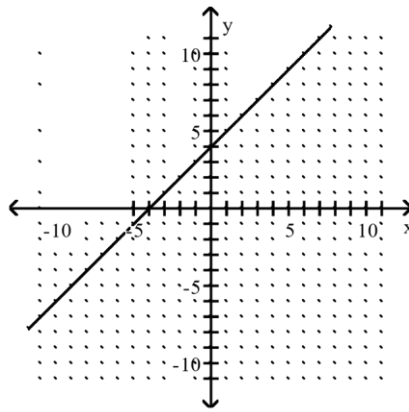
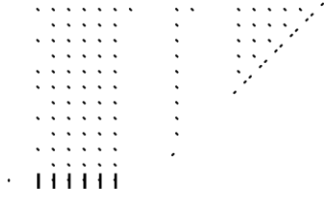

C)

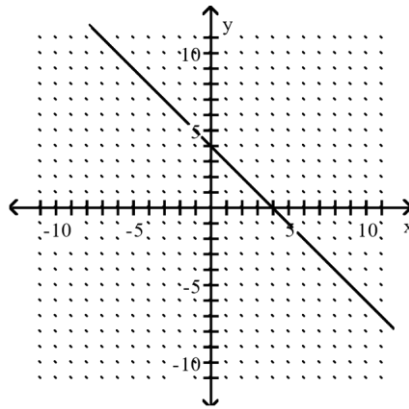

D)

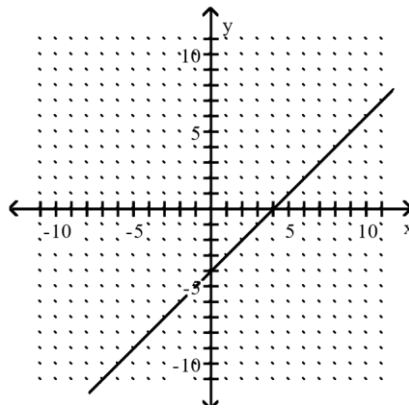

Answer: D

36) $y = 3x - 6$

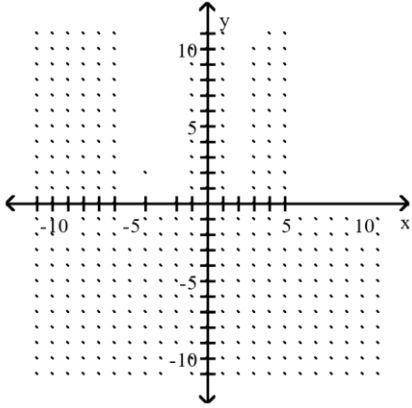

A)

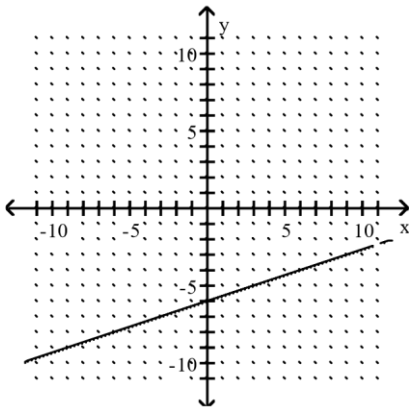

B)

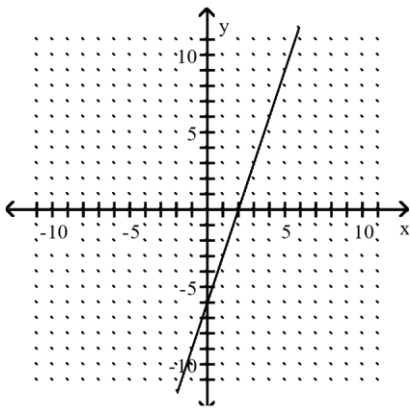

C)

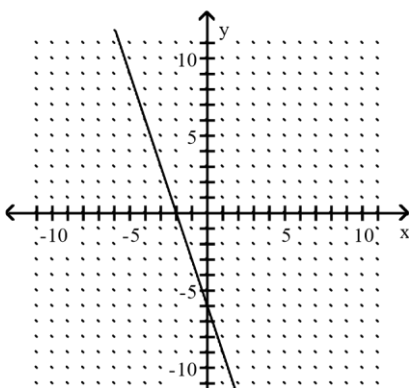



D)

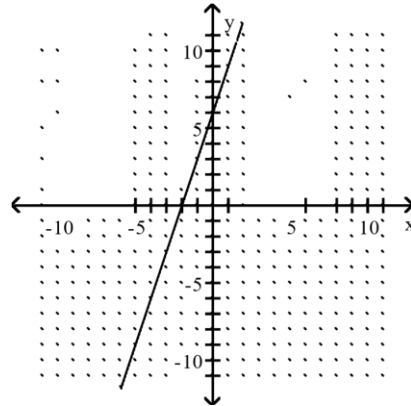

Answer: B

$$\frac{1}{2}y = x$$

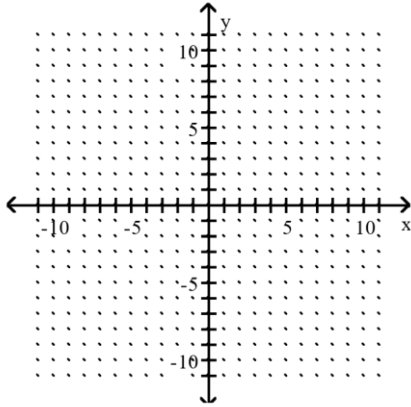

A)

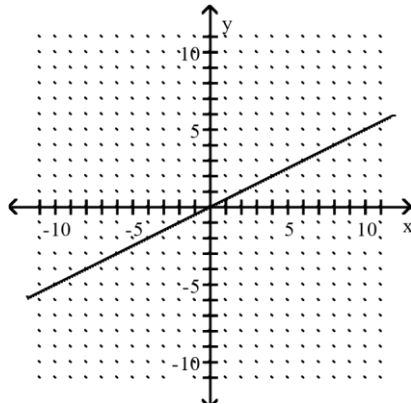

B)

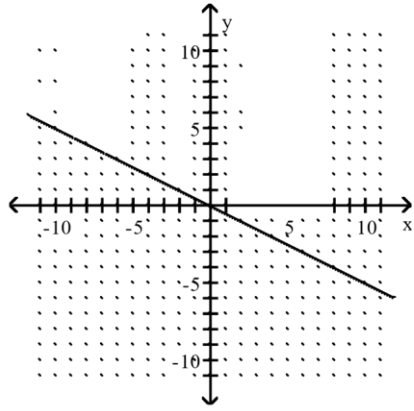
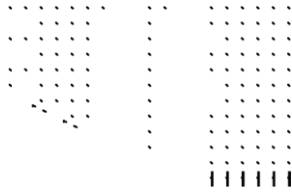

C)

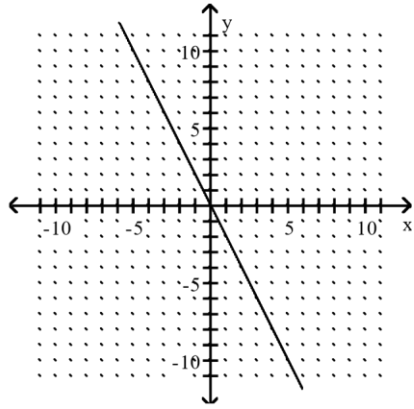

D)

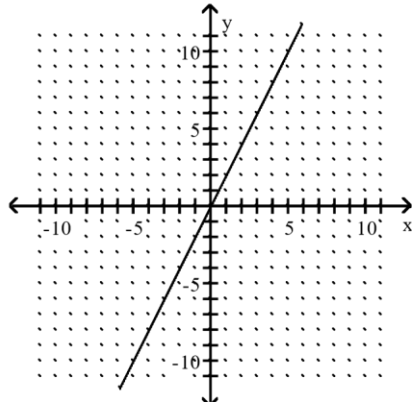

Answer: A

38) $y = 6x$

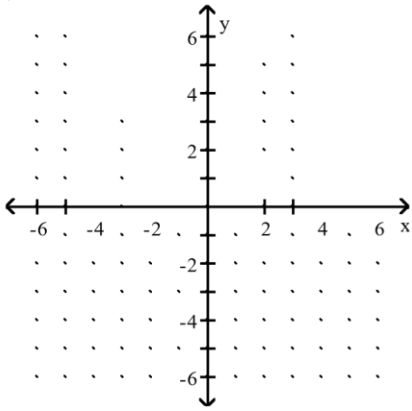

A)

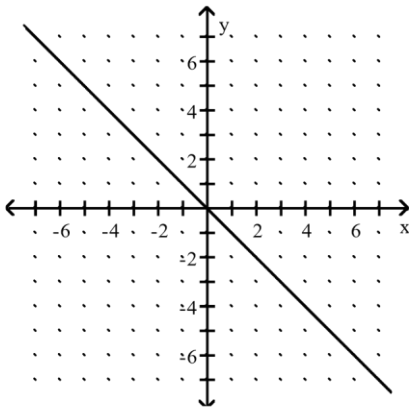

B)

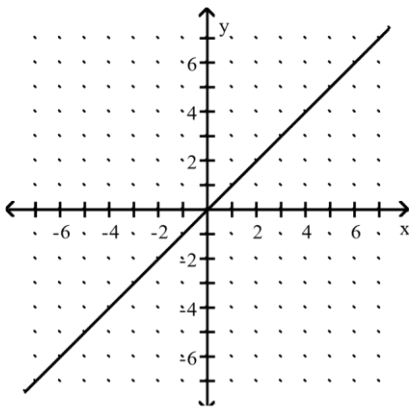

C)

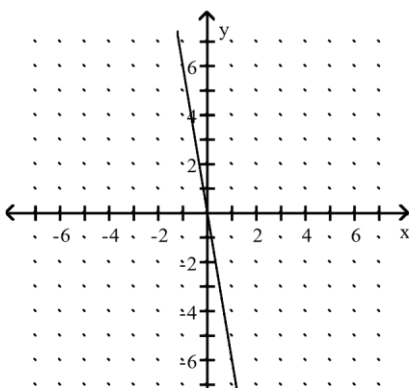

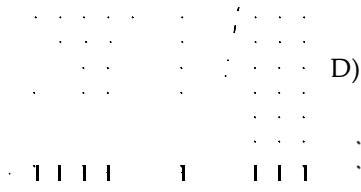

D)

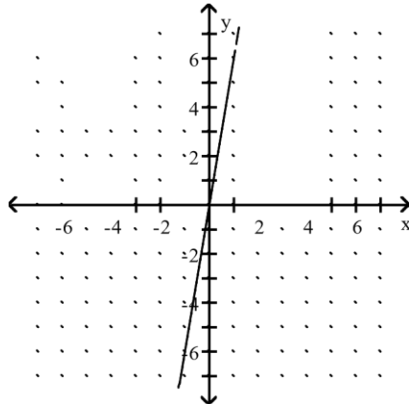

Answer: D

$$\frac{1}{5}y = x - 3$$

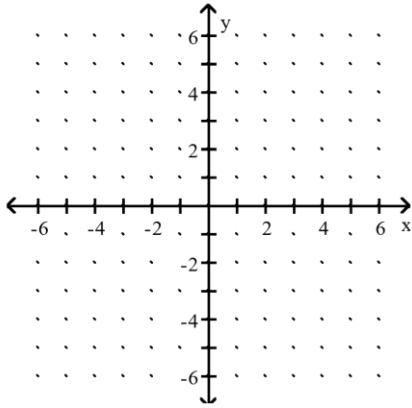

A)

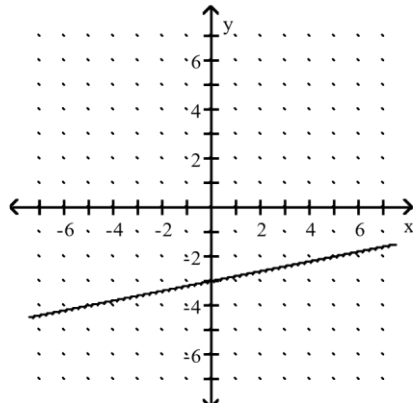

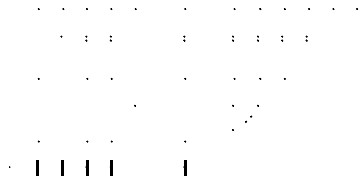

B)

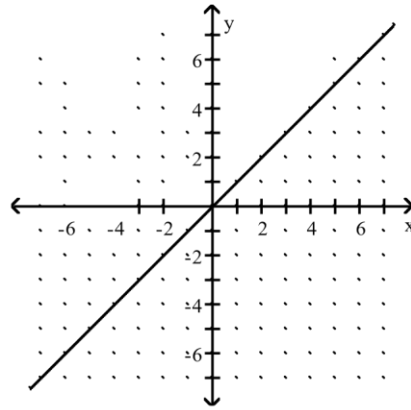

C)

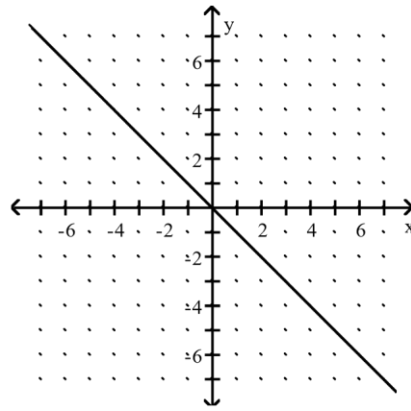

D)

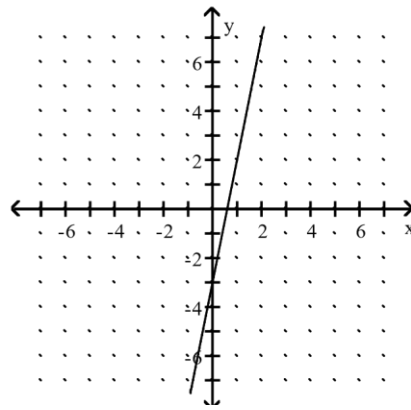

Answer: A

40) $y = x^2 + 1$

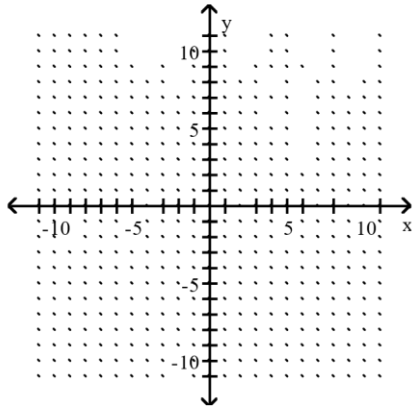

A)

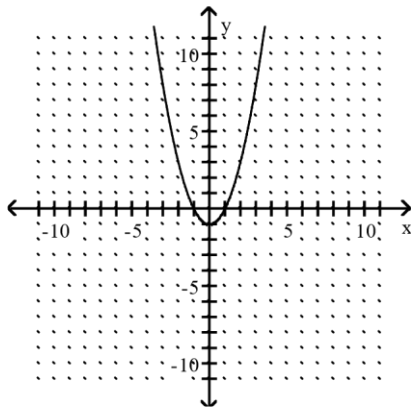

B)

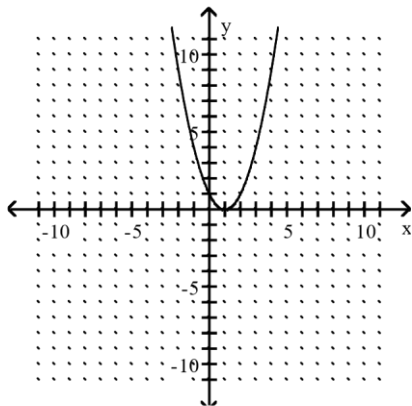

C)

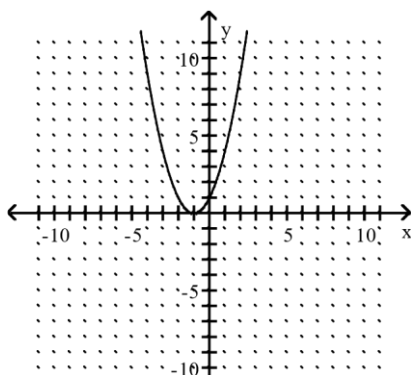

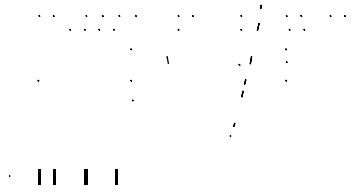

D)

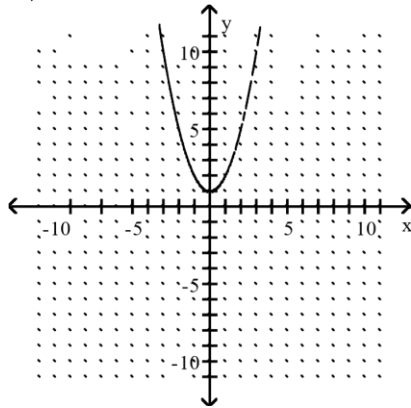

Answer: D

41) $y = 3 - x^2$

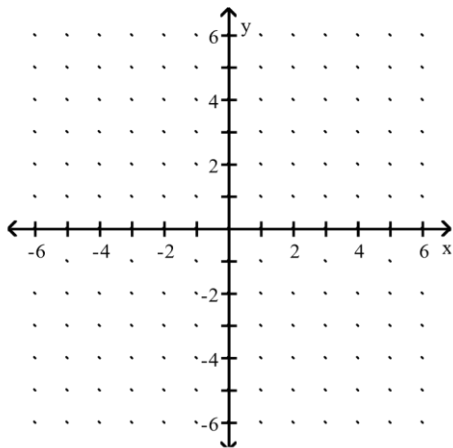

A)

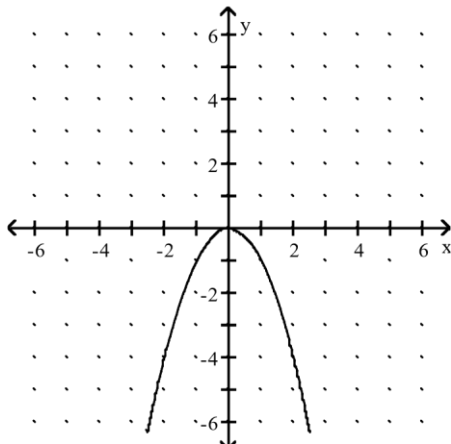

B)

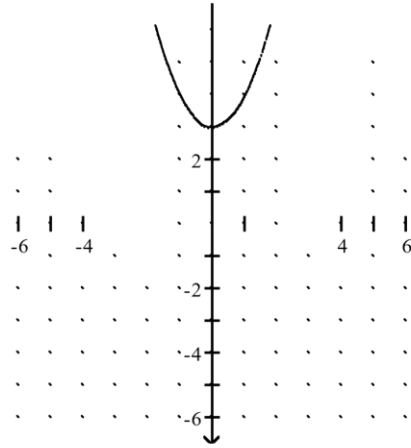
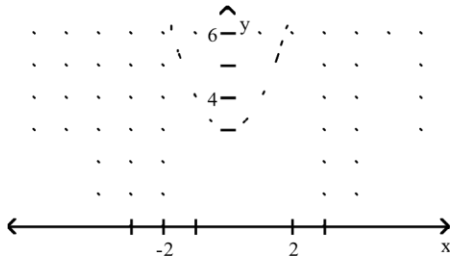

C)

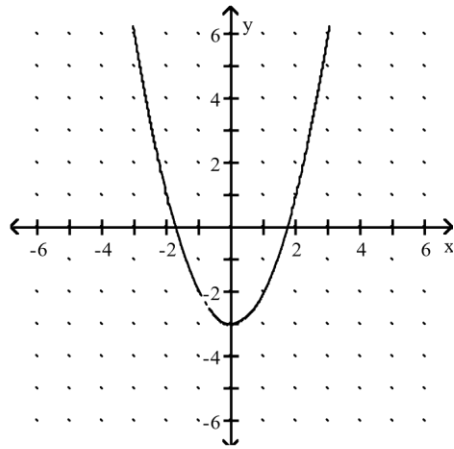

D)

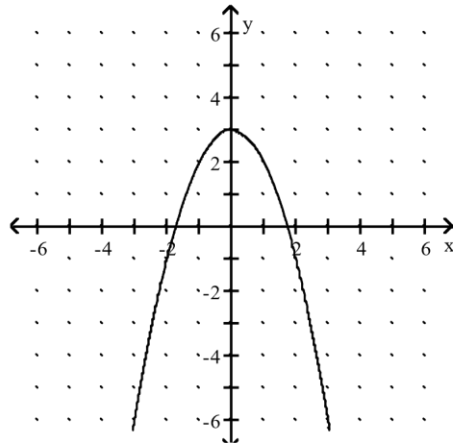

Answer: D

42) $y = |x| + 3$

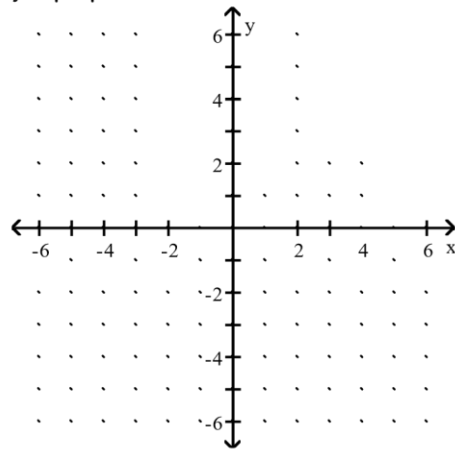

A)

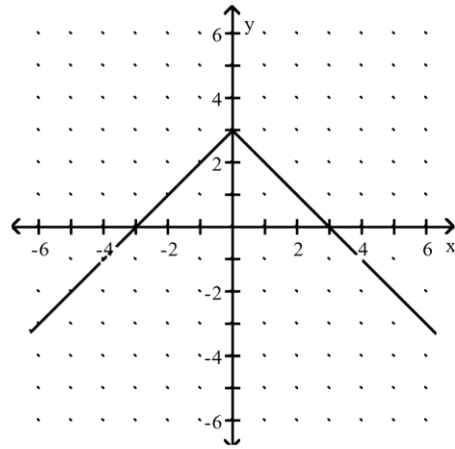

B)

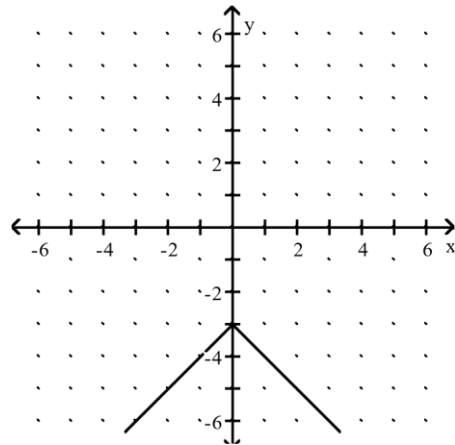

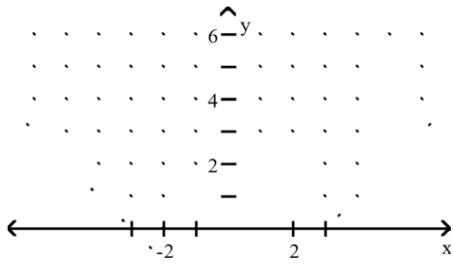

C)

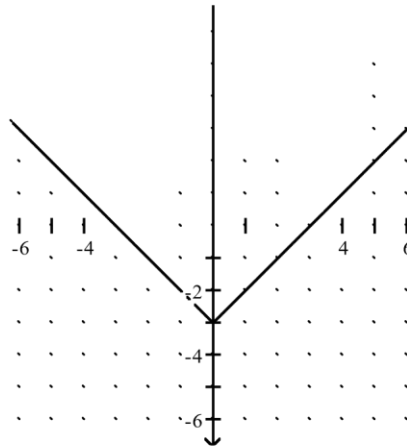

D)

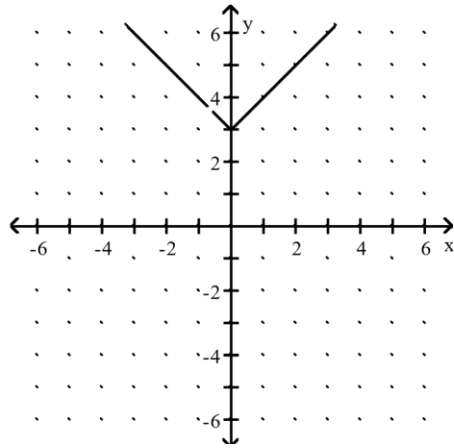

Answer: D

43) $y = -|x + 1|$

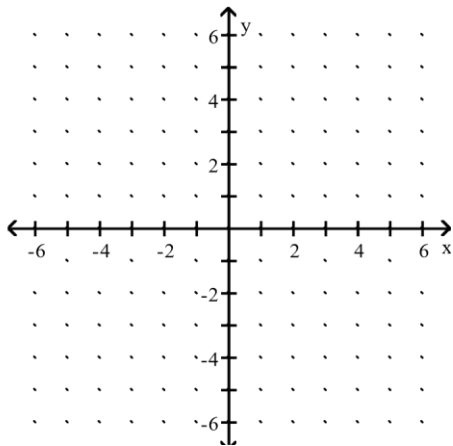

A)

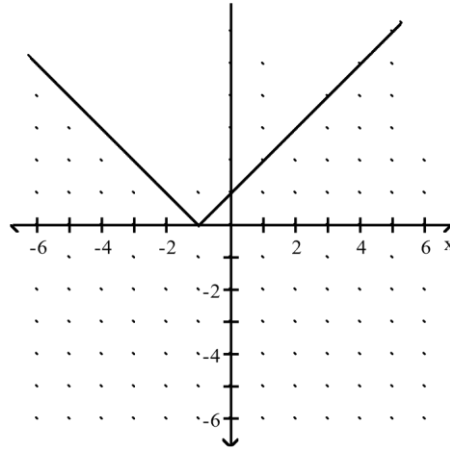
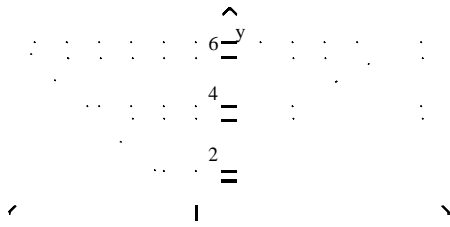

B)

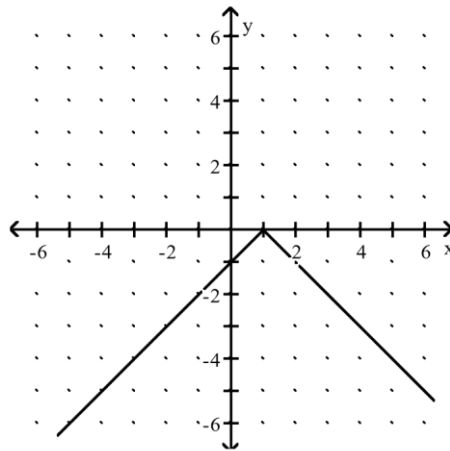

C)

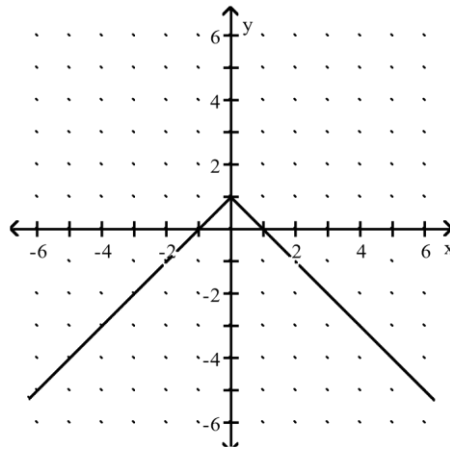

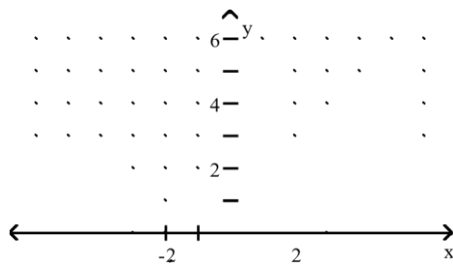

D)

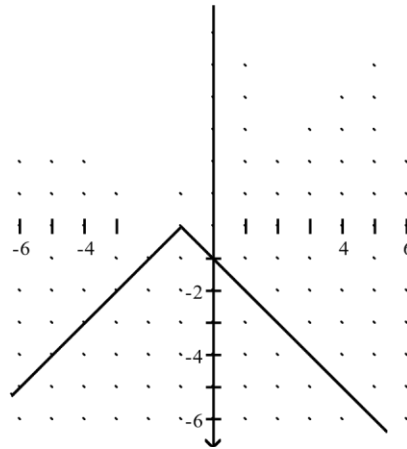

Answer: D

Is the following correspondence a function?

44)

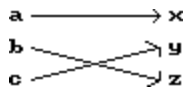

A) Yes

B) No

Answer: A

45)

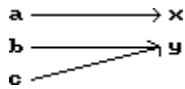

A) Yes

B) No

Answer: A

46)

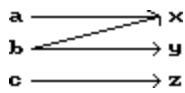

A) No

B) Yes

Answer: A

47)

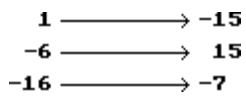

A) No

B) Yes

Answer: B

48)

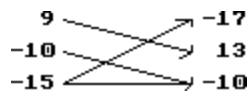

A) No

B) Yes

Answer: A

49)

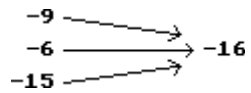

A) Yes

B) No

Answer: A

50)

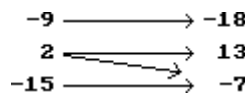

A) No

B) Yes

Answer: A

51) Domain: All students attending Laughlin Community College

Correspondence: Each student's Social Security Number

Range: A set of Social Security Numbers

A) Yes

B) No

Answer: A

52) Domain: All students attending the University of Ohio

Correspondence: Each student's teachers

Range: A set of teachers

A) Yes

B) No

Answer: B

53)53)

Name | Test Score

Bob L.	94
Susan H.	83
Jim H.	76
Bruce B.	96

- A) No
B) Yes

Answer: B

For the given correspondence, write the domain and the range. Then determine whether the correspondence is a function.

54) $\{(-8, -5), (-5, -10), (0, 8), (8, 3)\}$

- A) domain: $\{-8, -5, 0, 8\}$, range: $\{-10, -5, 3, 8\}$; No, it is a not a function.
B) domain: $\{-8, -5, 0, 8\}$, range: $\{-10, -5, 3, 8\}$; Yes, it is a function.
C) domain: $\{-10, -5, 3, 8\}$, range: $\{-8, -5, 0, 8\}$; No, it is a not a function.
D) domain: $\{-10, -5, 3, 8\}$, range: $\{-8, -5, 0, 8\}$; Yes, it is a function.

Answer: B

55) $\{(7, 2), (-6, 4), (4, -5), (7, -9)\}$

- A) domain: $\{-9, -5, 2, 4\}$, range: $\{-6, 4, 7\}$; No, it is a not a function.
B) domain: $\{-6, 4, 7\}$, range: $\{-9, -5, 2, 4\}$; Yes, it is a function.
C) domain: $\{-6, 4, 7\}$, range: $\{-9, -5, 2, 4\}$; No, it is a not a function.
D) domain: $\{-9, -5, 2, 4\}$, range: $\{-6, 4, 7\}$; Yes, it is a function.

Answer: C

56) $\{(-10, 1), (-2, -7), (0, -2), (9, 1)\}$

- A) domain: $\{-7, -2, 1\}$, range: $\{-10, -2, 0, 9\}$; Yes, it is a function. B) domain: $\{-10, -2, 0, 9\}$, range: $\{-7, -2, 1\}$; Yes, it is a function.
C) domain: $\{-7, -2, 1\}$, range: $\{-10, -2, 0, 9\}$; No, it is a not a function.
D) domain: $\{-10, -2, 0, 9\}$, range: $\{-7, -2, 1\}$; No, it is a not a function.

Answer: B

57) $\{(1, 9), (8, -8), (-9, -2), (4, 5), (-2, 0)\}$

- A) domain: $\{-8, -2, 0, 5, 9\}$, range: $\{-9, -2, 1, 4, 8\}$; Yes, it is a function.
B) domain: $\{-9, -2, 1, 4, 8\}$, range: $\{-8, -2, 0, 5, 9\}$; No, it is a not a function.
C) domain: $\{-9, -2, 1, 4, 8\}$, range: $\{-8, -2, 0, 5, 9\}$; Yes, it is a function.
D) domain: $\{-8, -2, 0, 5, 9\}$, range: $\{-9, -2, 1, 4, 8\}$; No, it is a not a function.

Answer: C

58) $\{(-5, -6), (2, 6), (1, 1), (-5, 7), (10, -2)\}$

- A) domain: $\{-6, -2, 1, 6, 7\}$, range: $\{-5, 1, 2, 10\}$; No, it is not a function.
- B) domain: $\{-6, -2, 1, 6, 7\}$, range: $\{-5, 1, 2, 10\}$; Yes, it is a function. C) domain: $\{-5, 1, 2, 10\}$, range: $\{-6, -2, 1, 6, 7\}$; Yes, it is a function.
- D) domain: $\{-5, 1, 2, 10\}$, range: $\{-6, -2, 1, 6, 7\}$; No, it is not a function.

Answer: D

59) $\{(-1, -8), (9, 6), (-7, -8), (2, -2), (-5, -1)\}$

- A) domain: $\{-7, -5, -1, 2, 9\}$, range: $\{-8, -2, -1, 6\}$; Yes, it is a function. B) domain: $\{-8, -2, -1, 6\}$, range: $\{-7, -5, -1, 2, 9\}$; Yes, it is a function.
- C) domain: $\{-8, -2, -1, 6\}$, range: $\{-7, -5, -1, 2, 9\}$; No, it is not a function. D) domain: $\{-7, -5, -1, 2, 9\}$, range: $\{-8, -2, -1, 6\}$; No, it is not a function.

Answer: A

The graph of a function f is provided. Determine the requested function value.

60) $f(2)$

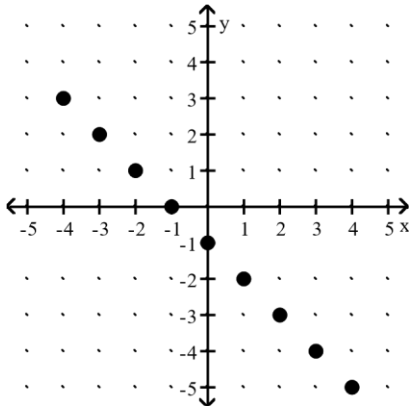

- A) -3
- B) -1
- C) 3
- D) 1

Answer: A

61) $f(-1)$

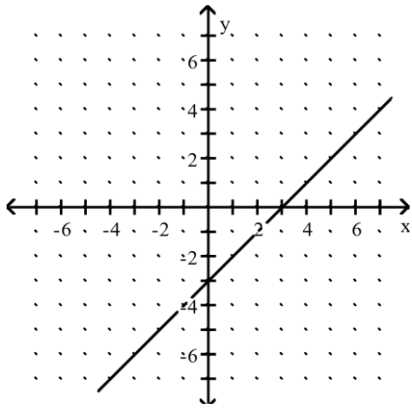

A) -2

B) -1

C) 2

D) -4

Answer: D

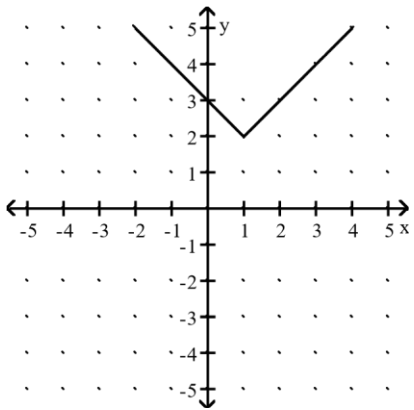

62) $f(-3)$

A) 0 B) 4 C) 2 D) 6

Answer: D

63) $f(-1)$

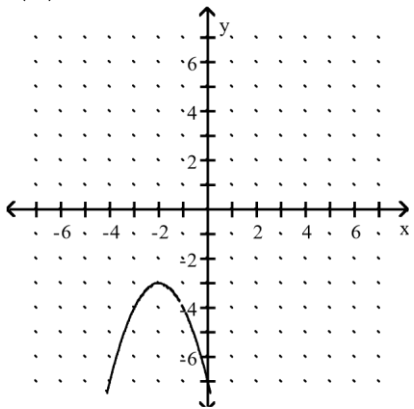

A) -28

B) -2

C) 2

D) -4

Answer: D

64) $f(-1)$

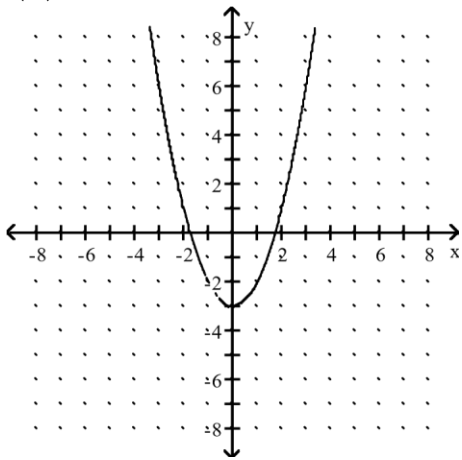

- A) 0
- B) 1
- C) -2
- D) -1

Answer: C

65) $f(1)$

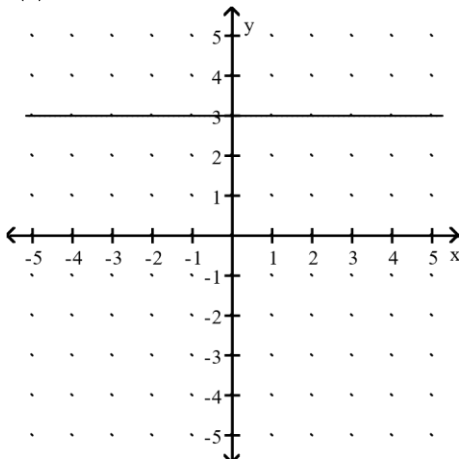

- A) -3
- B) Undefined

C) 3

D) 1

Answer: C

66) $f(2)$

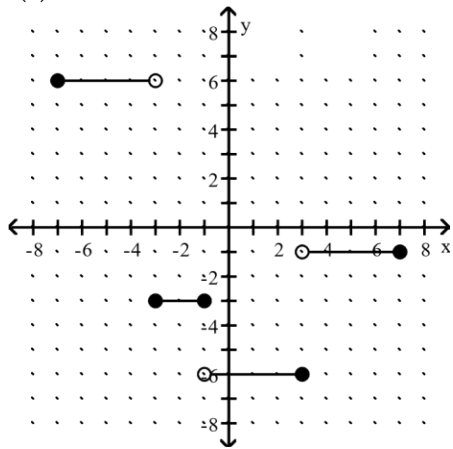

A) 2

B) -3

C) -6

D) -1

Answer: C

For the function represented in the graph, determine the domain or range, as requested. 67) Find the domain.

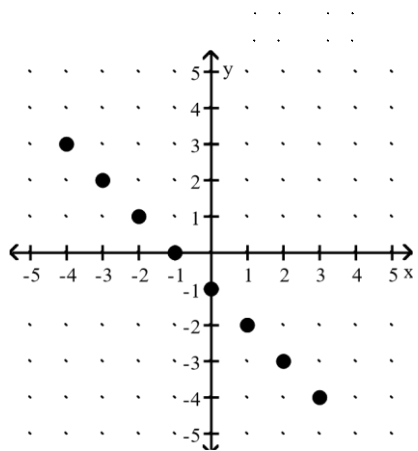

A) $\{-5, -4, -3, -2, -1, 0, 1, 2, 3\}$ B)

$\{x \mid -2 \leq x \leq 2\}$

C) $\{-4, -3, -2, -1, 0, 1, 2, 3\}$

D) $\{x \mid -4 \leq x \leq 4\}$

Answer: C

68) Find the domain.

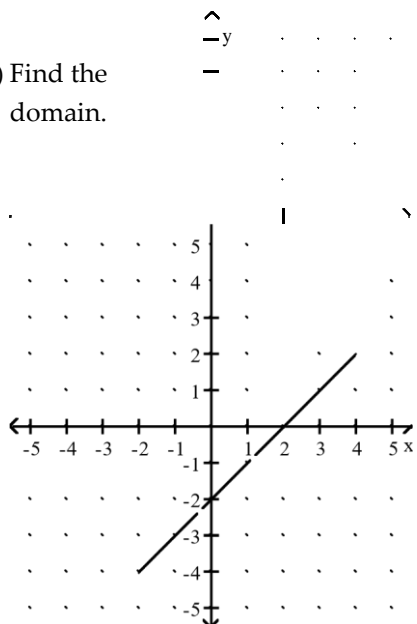

- A) $\{x \mid -4 \leq x \leq 6\}$
- B) $\{x \mid 3 \leq x \leq -3\}$
- C) $\{x \mid -5 \leq x \leq 5\}$
- D) $\{x \mid -2 \leq x \leq 4\}$

Answer: D

69) Find the domain.

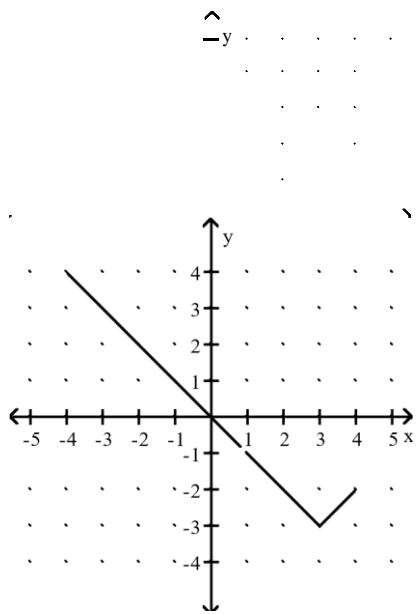

- A) $\{x \mid -2 \leq x \leq 4\}$
- B) $\{x \mid -2 \leq x \leq 2\}$
- C) $\{-5, -4, -3, -2, -1, 0, 1, 2, 3, 4, 5\}$
- D) $\{x \mid -4 \leq x \leq 4\}$

Answer: D

70) Find the range.

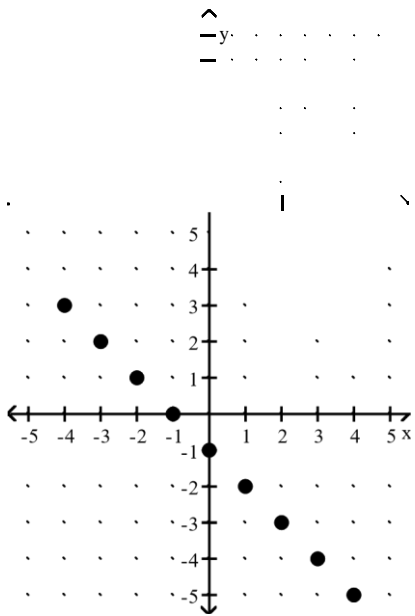

- A) $\{-4, -3, -2, -1, 0, 1, 2, 3, 4\}$
- B) $\{|y| - 1 \leq x \leq 1\}$
- C) $\{-5, -4, -3, -2, -1, 0, 1, 2, 3\}$
- D) $\{|y| - 5 \leq x \leq 3\}$

Answer: C

71) Find the range.

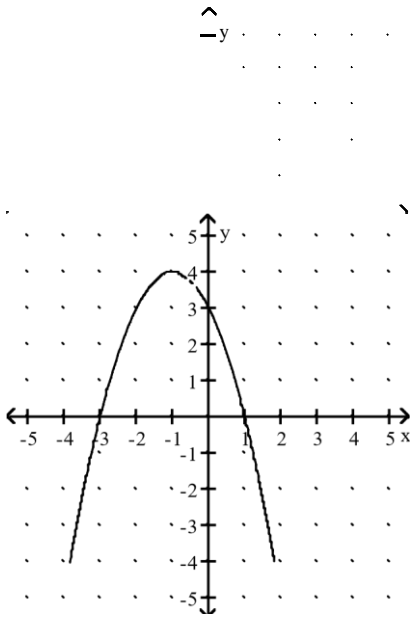

- A) $\{y \mid -1 \leq y \leq 1\}$
- B) $\{y \mid -4 \leq y \leq 4\}$
- C) $\{y \mid -5 \leq y \leq 5\}$
- D) $\{y \mid -3.83 \leq y \leq 1.83\}$

Answer: B

72) Find the range.

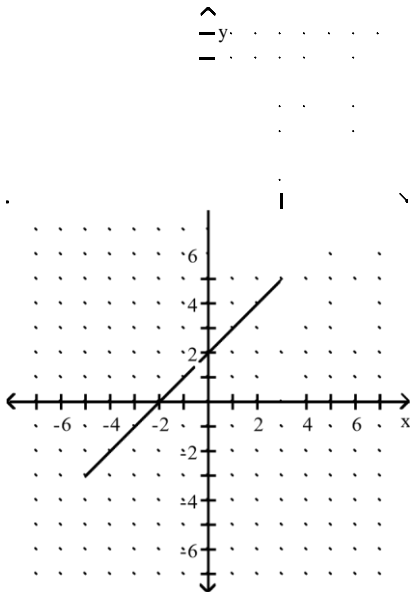

- A) $\{y \mid -3 \leq y \leq 5\}$
- B) $\{-3, -2, -1, 0, 1, 2, 3, 4, 5\}$
- C) $\{x \mid -5 \leq x \leq 3\}$
- D) $\{x \mid -5 \leq x \leq 5\}$

Answer: A

73) Find the range.

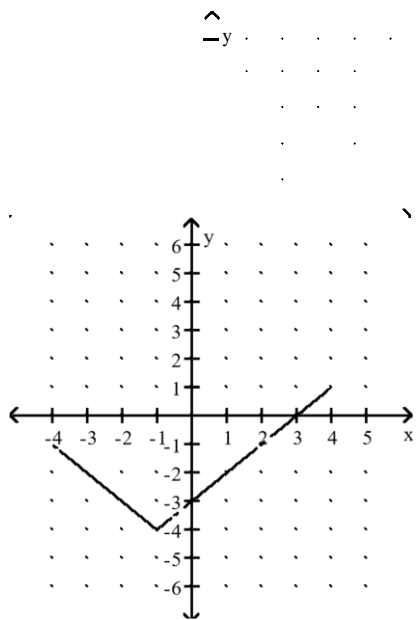

- A) $\{y \mid 1 \leq y \leq -1\}$
- B) $\{y \mid -5 \leq y \leq 5\}$
- C) $\{-5, -4, -3, -2, -1, 0, 1, 2, 3, 4, 5\}$
- D) $\{y \mid -4 \leq y \leq 1\}$

Answer: D

$\hat{\quad}$
 $\rightarrow y$

74) Find the domain.

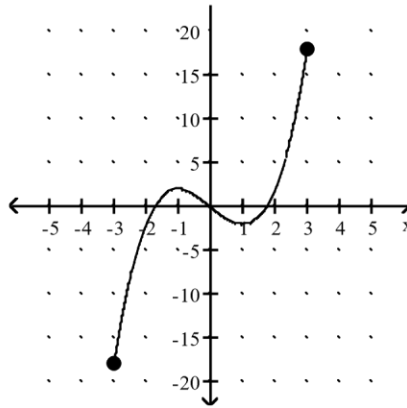

- A) $\{x \mid -5 \leq x \leq 5\}$
- B) $\{x \mid -3 \leq x \leq 3\}$
- C) $\{x \mid -18 \leq x \leq 18\}$
- D) $\{x \mid x \text{ is a real number}\}$

Answer: B

75) Find the domain.

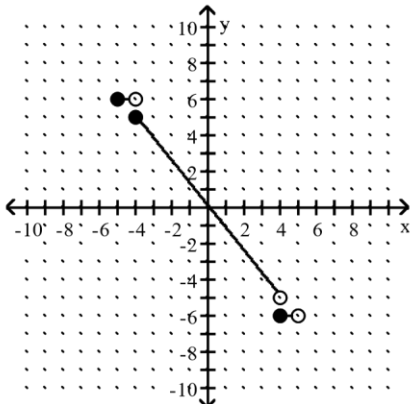

- A) $\{x \mid -5 \leq x < -4 \text{ or } -4 < x < 4 \text{ or } 4 < x \leq 5\}$
- B) $\{x \mid -5 \leq x < 5\}$
- C) $\{x \mid -4 \leq x < 4 \text{ or } x = -5 \text{ or } x = 5\}$
- D) $\{x \mid -5 < x < 5\}$

Answer: B

^
-y

76) Find the range.

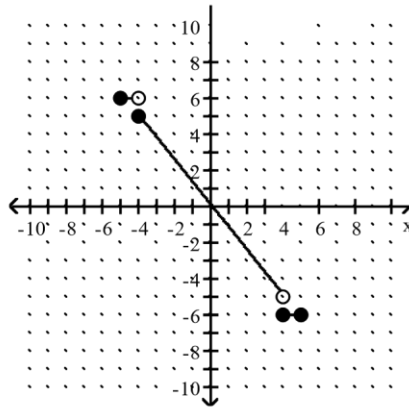

- A) $\{y \mid y = 6 \text{ or } -5 < y < 5 \text{ or } y = -6\}$
- B) $\{-6, -5, 5, 6\}$
- C) $\{y \mid y = 6 \text{ or } -5 < y \leq 5 \text{ or } y = -6\}$
- D) $\{y \mid -6 \leq y \leq 6\}$

Answer: C

A function of x is depicted in the graph. Find any input values that produce the indicated output.

77) $f(x) = -4$

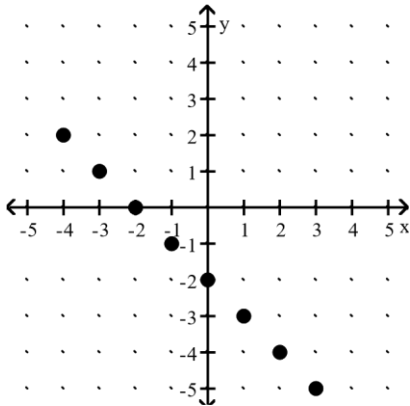

A) 3

\hat{y}

- B) 2
- C) 4
- D) -4

Answer: B

|| | | \

78) $f(x) = 2$

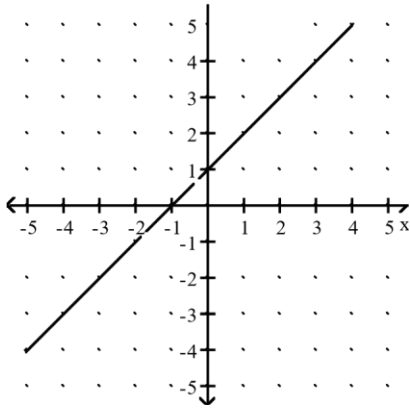

- A) 1 B) -1
- C) 0
- D) 3

Answer: A

79) $f(x) = -2$

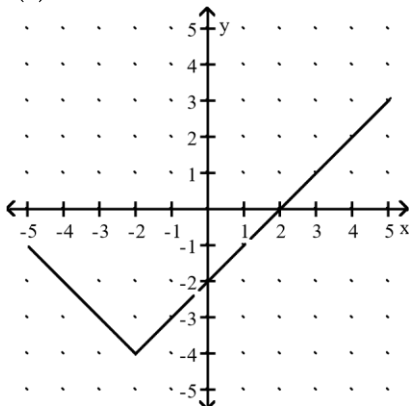

\hat{y}

A) $x = -4$ and $x = 0$ B) $x = 4$ and $x = 0$

C) $x = -4$

D) $x = -8$ and $x = 4$

Answer: A

80) $f(x) = 0$

\hat{y}
 \hat{x}

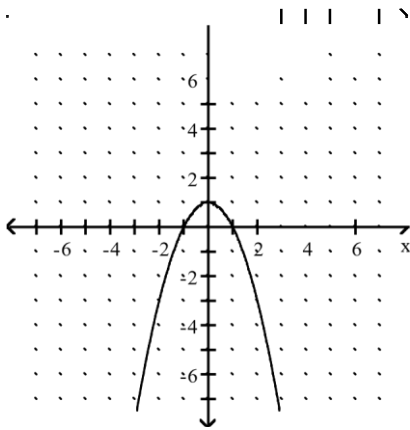

- A) $x = 1$
- B) $x = -2$ and $x = 2$
- C) $x = 1$ and $x = -1$
- D) $x = -1$

Answer: C

81) $f(x) = -4$

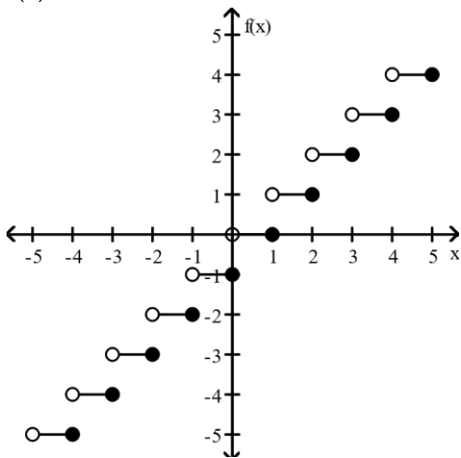

- A) $\{x \mid -4 < x \leq -3\}$ B) $\{x \mid -4 \leq x \leq -3\}$
- C) -3
- D) $\{x \mid -4 < x < -3\}$

Answer: A

Determine whether the graph is the graph of a function.

82)

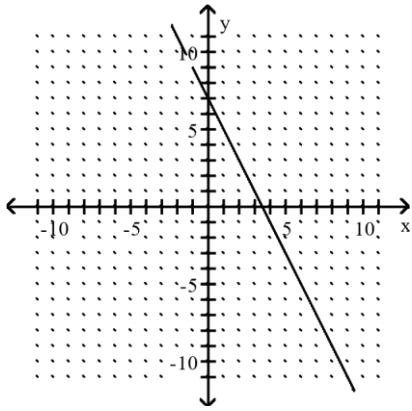

- A) Yes
- B) No

Answer: A

83)

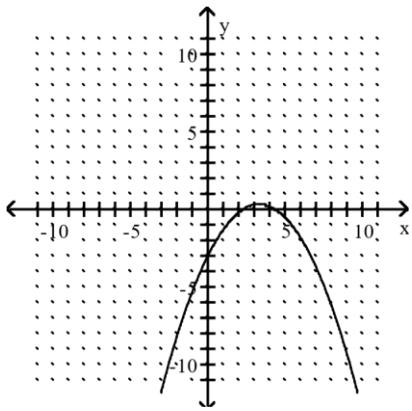

- A) No
- B) Yes

Answer: B

84)

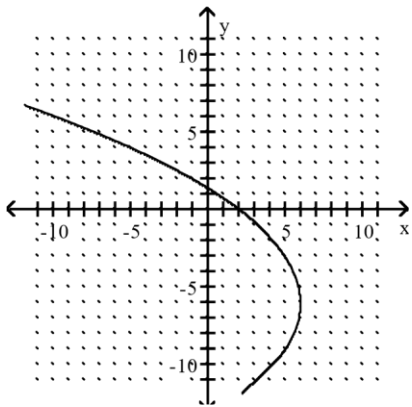

- A) Yes
- B) No

Answer: B

85)

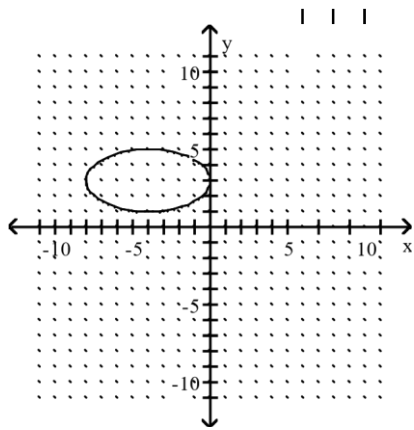

A) Yes

B) No

Answer: B

86)

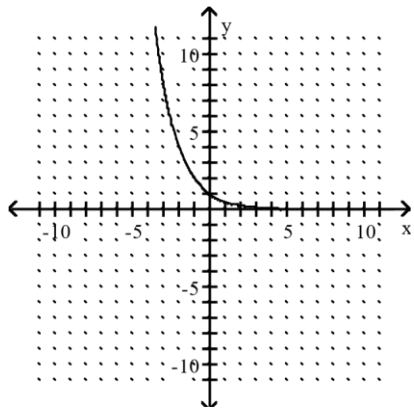

A) No

B) Yes

Answer: B

87)

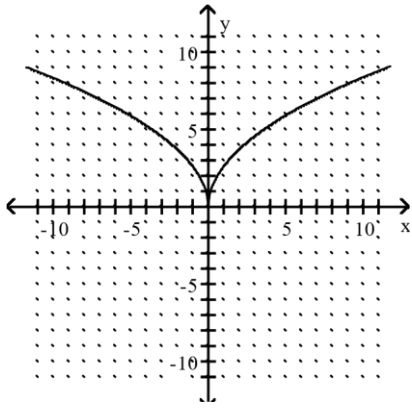

- A) No
- B) Yes

Answer: B

88)

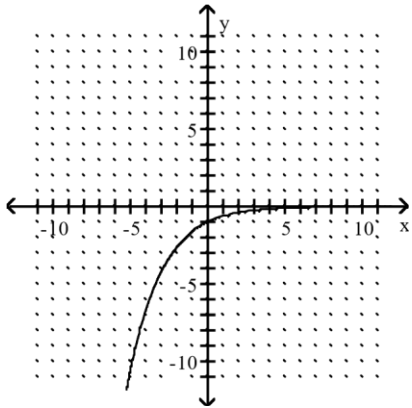

- A) Yes
- B) No

Answer: A

89)

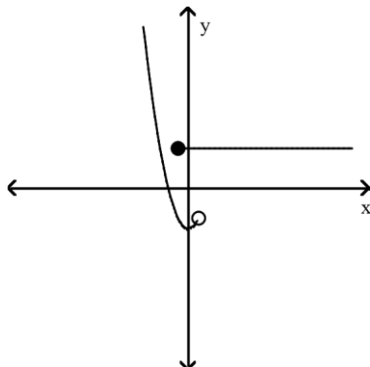

- A) No
- B) Yes

Answer: A

90)

:

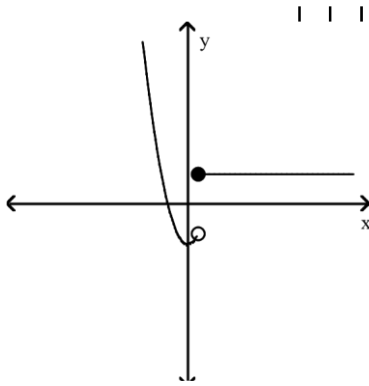

A) No

B) Yes

Answer: B

91)

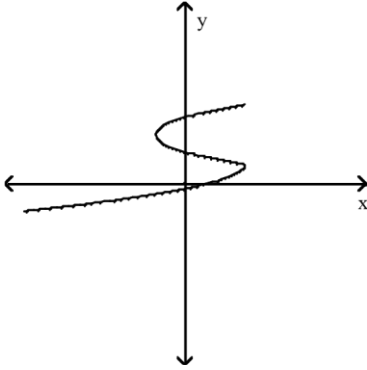

A) No

B) Yes

Answer: A

Find the function value.

92) Find $f(8)$ when $f(x) = -|x - 3|$.

A) 3

B) 8

C) 5

D) -5

Answer: D

93) Find $f(5)$ when $f(x) = -x + 9$.

A) 20

B) 4

C) -4

D) 5

Answer: B

94) Find $f(1)$ when $f(x) = -2x - 7$.

A) 14

B) -7

C) -9

D) 6

A) 9

B) 0

C) 24

D) 26

Answer: C

95) Find $f(-1)$ when $f(x) = x^2 + 5x - 4$.

Answer: C

96) Find $f(-1)$ when $f(x) = \frac{x - 8}{3x + 6}$.

- A) 1
- B) -3
- C) $-\frac{4}{9}$
- D) 3

Answer: B

97) Find $f(a - 3)$ when $f(x) = x^2 + 2$.

- A) $a^2 + 9$
- B) $a^2 - 6a + 9$
- C) $a^2 - 6a + 11$
- D) $a^2 - 1$ Answer: C

98) Find $g(a + 1)$ when $g(x) = 2x - 4$.

- A) $\frac{1}{2}a - 4$
- B) $2a - 4$
- C) $2a - 1$
- D) $2a - 2$ Answer: D

99) Find $f(2a)$ when $f(x) = 6x^2 + 8x$.

- A) $24a^2 + 8a$ B) $12a^2 + 16a$
- C) $24a^2 + 16a$
- D) $40a$

Answer: C

100) Find $f(x - 2)$ when $f(x) = \frac{2x - 5}{3x + 4}$.

- A) $\frac{2x - 7}{3x - 2}$
- B) $\frac{2x - 9}{3x + 4}$
- _____

- $2x - 7$
- C) $3x + 2$
- $2x - 9$
- D) $3x - 2$

Answer: D

101) Find $f(8 + 10t)$ when $f(x) = -17$.

- A) -162
- B) $-136 + 10t$
- C) -17
- D) $-136 - 170t$ Answer: C

Find the domain of $f(x)$.

$$f(x) = \frac{-7}{x - 102} + 3$$

- A) $\{x \mid x \text{ is a real number and } x \neq 3\}$
- B) $\{x \mid x \text{ is a real number and } x \neq 7\}$
- C) $\{x \mid x \text{ is a real number and } x \neq -3\}$
- D) $\{x \mid x \text{ is a real number and } x \neq -7\}$

Answer: A

$$f(x) = \frac{7}{-4 - x} + 103$$

- A) $\{x \mid x \text{ is a real number and } x \neq -4\}$
- B) $\{x \mid x \text{ is a real number and } x \neq 7\}$
- C) $\{x \mid x \text{ is a real number and } x \neq -7\}$
- D) $\{x \mid x \text{ is a real number and } x \neq 4\}$

Answer: A

104) $f(x) = -5x + 3$

- A) $\{x \mid x \text{ is a real number and } x \neq 0.6\}$
- B) $\{x \mid x \text{ is a real number and } x \neq -5\}$
- C) $\{x \mid x \text{ is a real number and } x \neq 3\}$
- D) the set of all real numbers

Answer: D

105) $f(x) = x^2 + 8$

- A) $\{x \mid x \text{ is a real number and } x \neq 8\}$
- B) $\{x \mid x \text{ is a real number and } x \neq \sqrt{8}\}$
- C) $\{x \mid x \text{ is a real number and } x \neq -8\}$
- D) the set of all real numbers

Answer: D

106) $f(x) = 4x + 7$

A) $\{x \mid x \text{ is a real number and } x \neq -\frac{7}{4}\}$

B) x the set of all real numbers

C) $\{x \mid x \text{ is a real number and } x \neq -0.5714286\}$ D) $\{x \mid x \text{ is a real number and } x \neq -7\}$

Answer: B

107) $f(x) = 28 - x$ A) x the set of all real numbers B) $\{x \mid x \text{ is a real number and } x \neq -28\}$ C) $\{x \mid x \text{ is a real number and } x \neq 28\}$ D) $\{x \mid x < 28\}$

Answer: A

108) $f(x) = x^3 - 8$

A) $\{x \mid x \text{ is a real number and } x \neq -8\}$

B) $\{x \mid x \text{ is a real number and } x \neq 8\}$

C) x the set of all real numbers

D) $\{x \mid x \text{ is a real number and } x \neq \sqrt[3]{-8}\}$

Answer: C

109) $f(x) = \sqrt{4x + 1}$

A) $\left\{x \mid x \geq -\frac{1}{4}\right\}$

B) $\left\{x \mid x \neq -\frac{1}{4}\right\}$

C) $\left\{x \mid x \geq \frac{1}{4}\right\}$

D) $\left\{x \mid x > -\frac{1}{4}\right\}$

Answer: A

110) $f(x) = \sqrt{2 - x}$

A) $\{x \mid x < 2\}$

B) $\{x \mid x \geq 2\}$

C) $\{x \mid x \neq 2\}$

D) $\{x \mid x \leq 2\}$

Answer: D

111) $f(x) = x$

- $\overline{4x + 6}$
- A) $\left\{ \begin{array}{l} x \\ x \text{ is a real number} \\ \neq \frac{3}{2} \end{array} \right\}$ and x
- B) $\left\{ \begin{array}{l} x \\ x > \frac{3}{2} \end{array} \right\}$
- C) $\left\{ \begin{array}{l} x \\ x \text{ is a real number} \\ \text{and } x \\ \neq \frac{3}{2} \end{array} \right\}$
- D) $\left\{ \begin{array}{l} x \\ x \text{ is a real number} \\ \text{and } x \\ \neq \frac{2}{3} \end{array} \right\}$

Answer: A

Solve the problem.

- 112) The function A described by $A(s) = s^2$ gives the area of an equilateral triangle with side s . Find the area 4 when a side measures 8 cm. Express your answer in radical form.

- A) $2\sqrt{3} \text{ cm}^2$
- B) $4\sqrt{3} \text{ cm}^2$
- C) 16 cm^2
- D) 48 cm^2

Answer: C

- 113) The function A described by $A(s) = s^2$ gives the area of an equilateral triangle with side s . Find the area 4 when a side measures 14 cm. Express your answer in radical form.

- A) $7\sqrt{3} \text{ cm}^2$
- B) $3.5\sqrt{3} \text{ cm}^2$
- C) 49 cm^2
- D) 147 cm^2

Answer: C

- 114) The function A described by $A(r) = 4\pi r^2$ gives the surface area of a sphere with radius r . Find the area when the radius is 1 in.

- A) 37.7 in.^2
- B) 4 in.^2
- C) 3.14 in.^2

D) 12.57 in.^2

Answer: D

115) The function F described by $F(C) = \frac{9}{5}C + 32$ gives the Fahrenheit temperature corresponding to the Celsius temperature C . Find the Fahrenheit temperature equivalent to -5°C .

- A) 14°F
- B) -4°F
- C) 5°F
- D) 23°F

Answer: D

116) The function H described by $H(x) = 2.75x + 71.48$ can be used to estimate the height, in centimeters, of a woman whose humerus (the bone from the elbow to the shoulder) is x cm long. Estimate the height of a woman whose humerus is 32.6 cm long.

- A) 18.17 cm
- B) 41.63 cm
- C) 161.13 cm
- D) 106.83 cm

Answer: C

117) The function h described by $h(t) = -16t^2 + 33.1t + 124.26$ gives the height of a ball thrown upward with a speed of 33.1 feet per second from a 124.26 ft high window t seconds after it is thrown until it hits the ground. Find the height of the ball 1.5 seconds after it is thrown.

- A) 38.61 ft
- B) 110.61 ft
- C) 209.91 ft
- D) 137.91 ft

Answer: D

118)118)

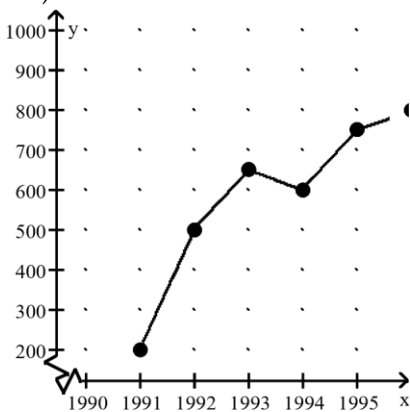

Crafty Bill's Cool Car Sales opened as a used car sales lot in 1991. The graph shows the number of cars sold as a function of time. What is the approximate number of cars sold in 1993?

- A) 650
- B) 250
- C) 500
- D) 600

Answer: A

119)119)

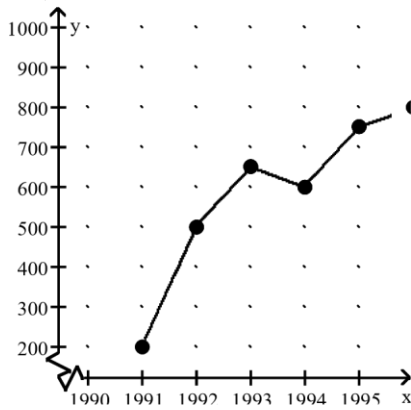

Crafty Bill's Cool Car Sales opened as a used car sales lot in 1991. The graph shows the number of cars sold as a function of time. What is the approximate number of cars sold in 1995?

- A) 600
- B) 750
- C) 700
- D) 350

Answer: B

120) The town of Appleville recorded the following dates and populations.

YEAR	POPULATION (in thousands)
1980	41.5
1985	43
1990	46
1995	52

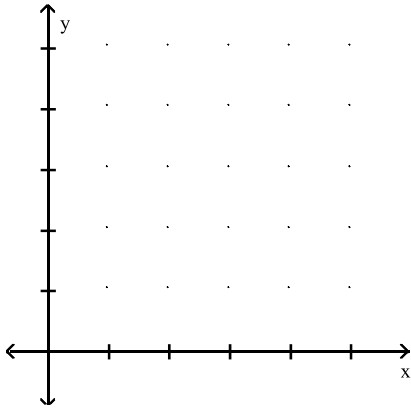

Draw a graph of the population as a function of time. What is the approximate population of Appleville in 1988?

- A) 44,000
- B) 46,000
- C) 45,000
- D) 43,000

Answer: C

121) The table below shows the population of a city in various years. Use the data to draw a graph of the population as a function of time. Use the graph to estimate when the population reached 6.4 million

Year	Population (millions)
1950	1.1
1960	1.8
1970	2.9
1980	4.8
1990	7.7

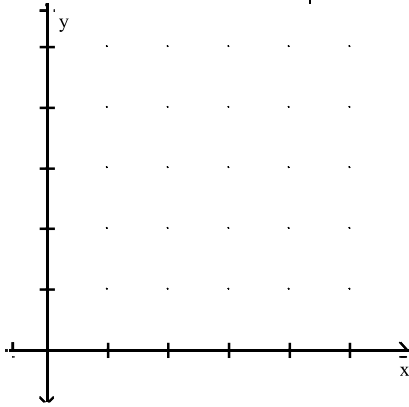

- A) 1984
- B) 1986
- C) 1985
- D) 1987

Answer: B

Graph.

122) $f(x) = x + 4$

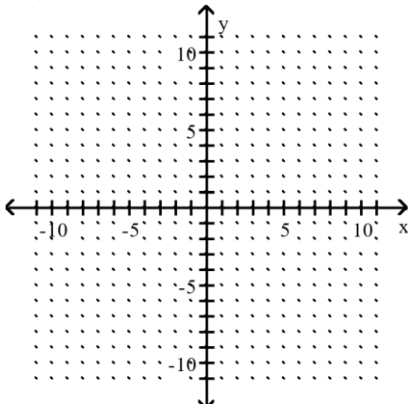

A)

.....
.....
.....
.....
.....

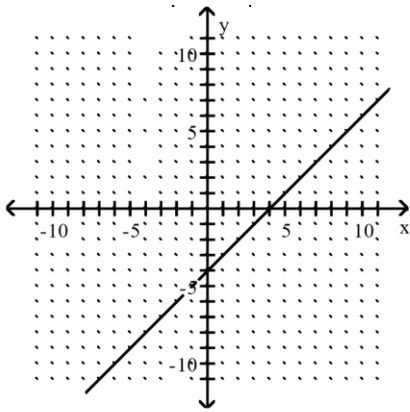

B)

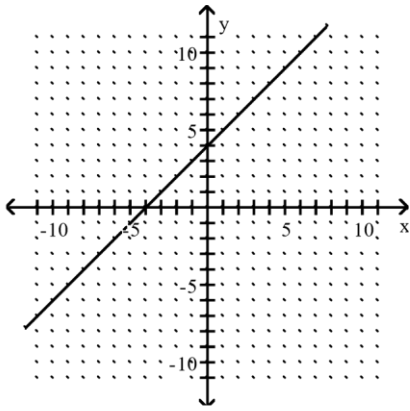

C)

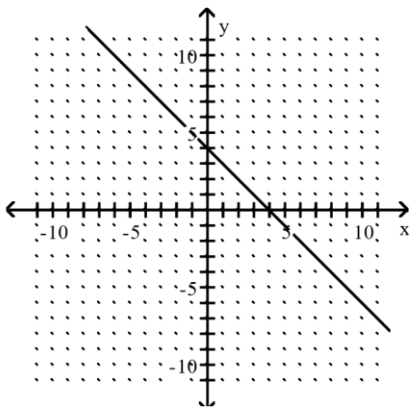

D)

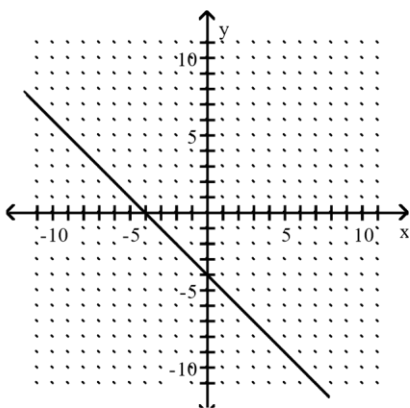

Answer: B

.....
.....
.....
.....
.....

123) $f(x) = 2x + 6$

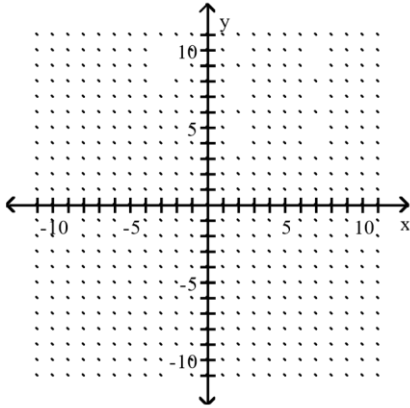

A)

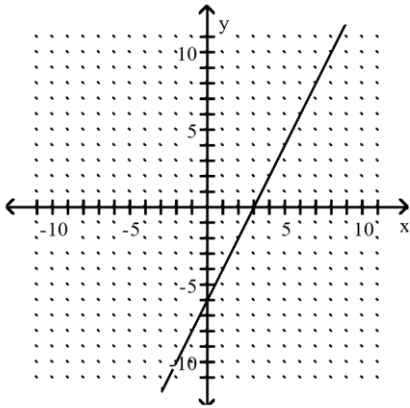

B)

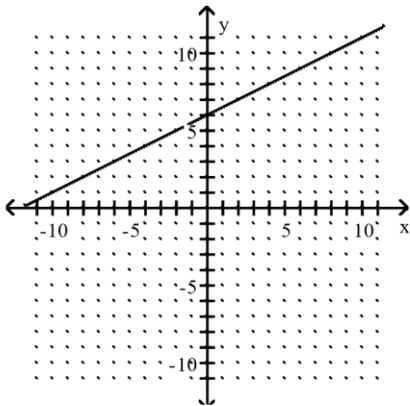

C)

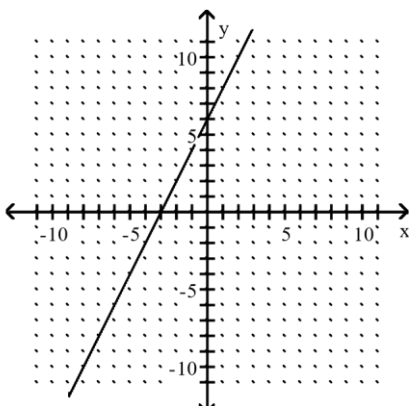

D)

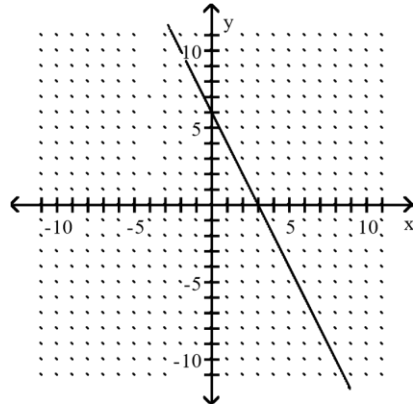

Answer: C

$$\frac{1}{4} f(x) = x - 1$$

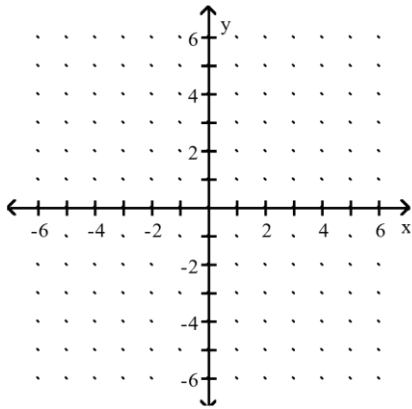

A)

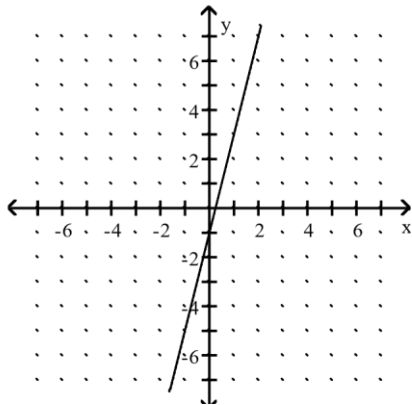

B)

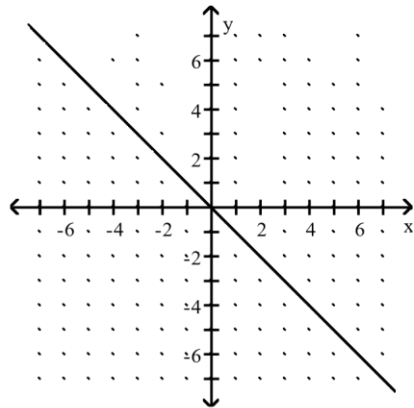

C)

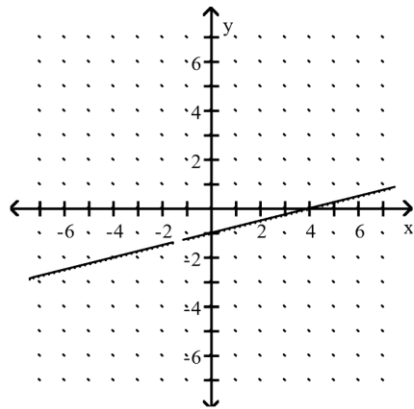

D)

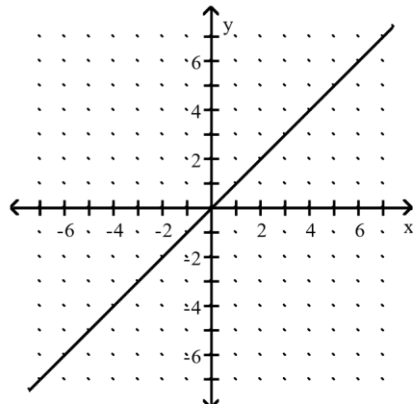

Answer: C

125) $f(x) = -5x + 4$

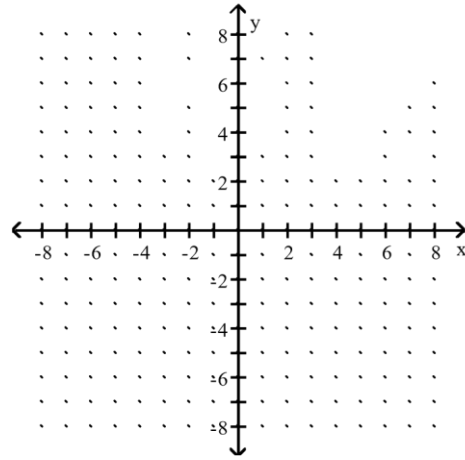

A)

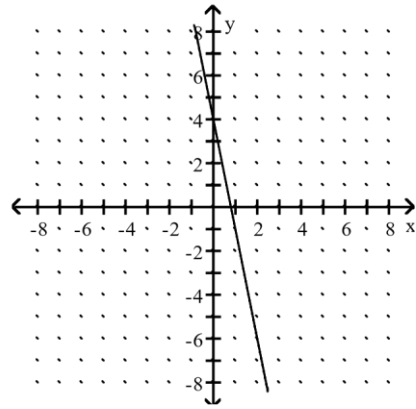

B)

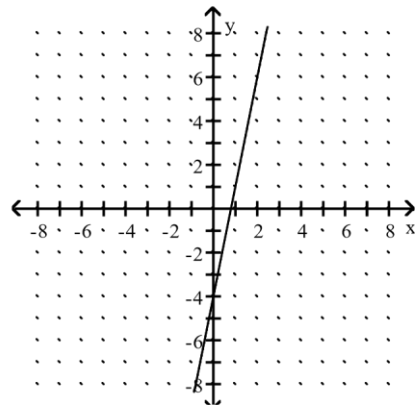

C)

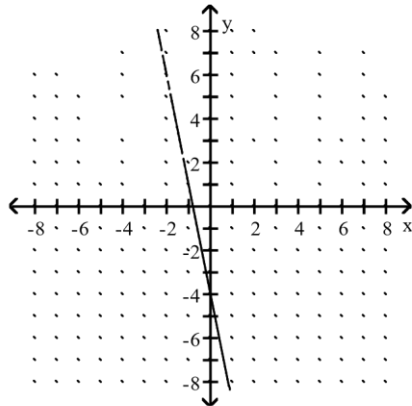
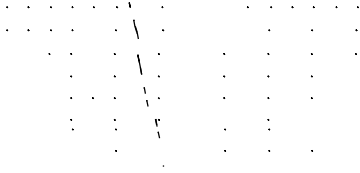

D)

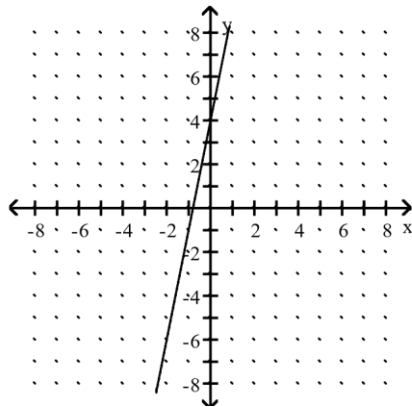

Answer: A

126) $f(x) = -\frac{1}{2}x - 6$

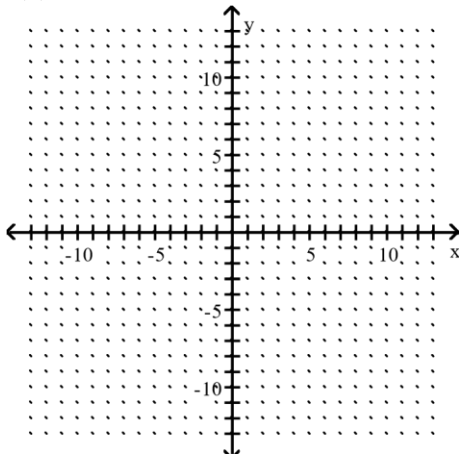

A)

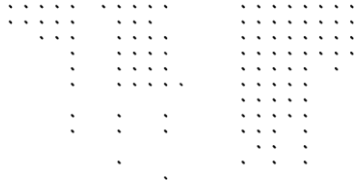

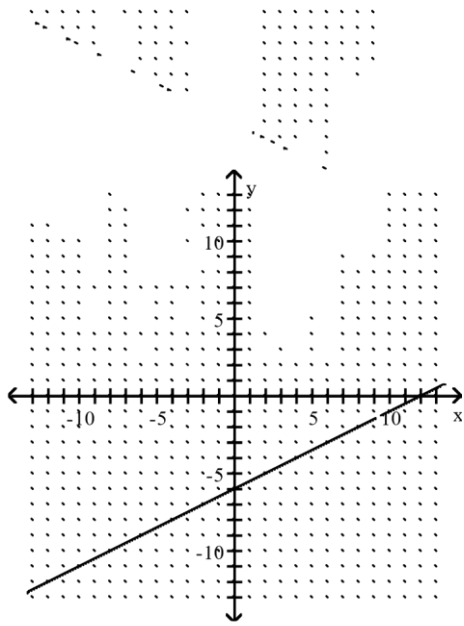

B)

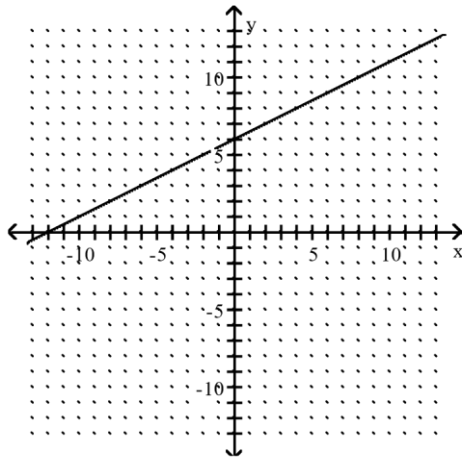

C)

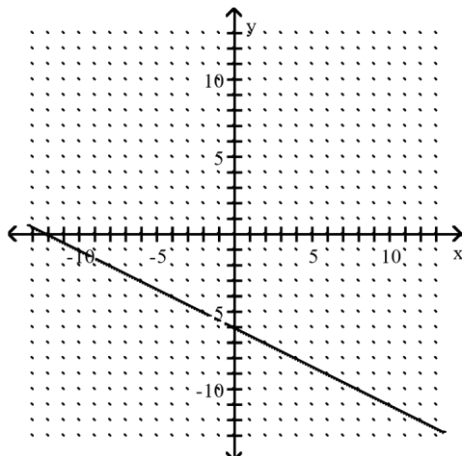

D)

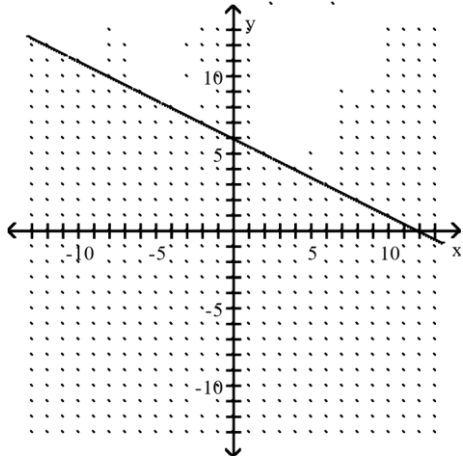

Answer: C

$$127) f(x) = -\frac{1}{2}x$$

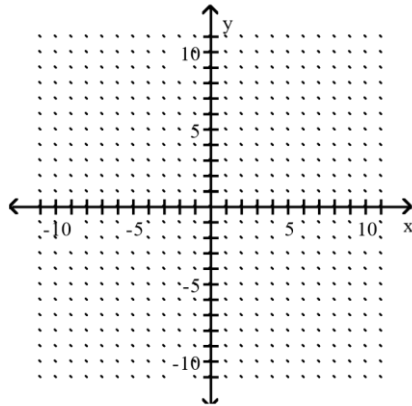

A)

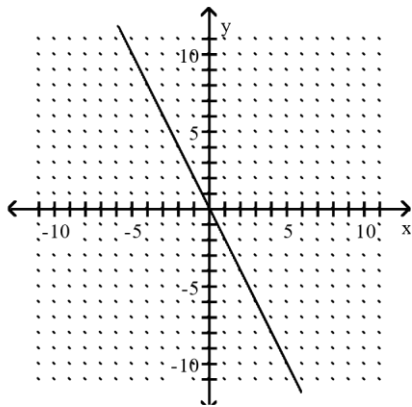

B)

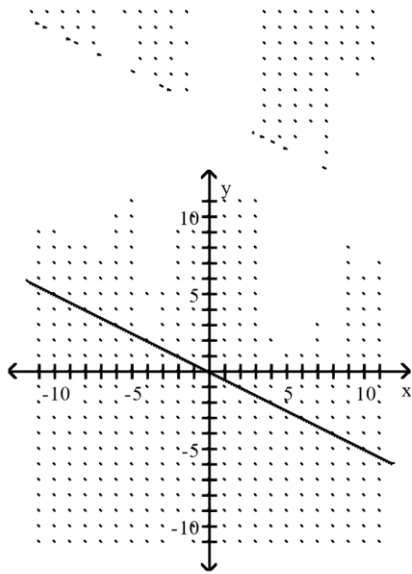

C)

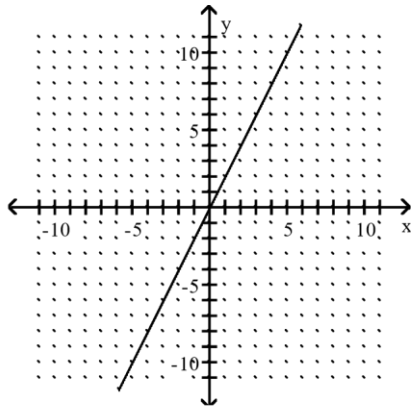

D)

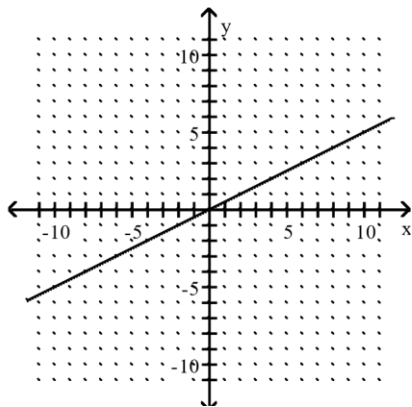

Answer: B

Determine the slope and the y-intercept.

128) $y =$
 $8x + 6$

- A) Slope = -8, y-intercept = (0, 6)
- B) Slope = 6, y-intercept = (0, -8)
- C) Slope = 8, y-intercept = (0, 6)
- D) Slope = 6, y-intercept = (0, 8)

Answer: C

129) $y = -5x - 2$

- A) Slope = 5, y-intercept = (0, -2) B) Slope = -5, y-intercept = (0, -2)
C) Slope = -2, y-intercept = (0, -5) D)
Slope = -2, y-intercept = (0, 5)

Answer: B

130) $y = 4.7x + 8$

- A) Slope = 8, y-intercept = (0, -4.7) B) Slope = 4.7, y-intercept = (0, 8)
C) Slope = 8, y-intercept = (0, 4.7)
D) Slope = -4.7, y-intercept = (0, 8)

Answer: B

131) $y = -36x + 974$

- A) Slope = -36, y-intercept = (0, 974) B) Slope = 974, y-intercept = (0, 36)
C) Slope = 36, y-intercept = (0, 974)
D) Slope = 974, y-intercept = (0, -36)

Answer: A

132) $y = -\frac{6}{5}x - 4.5$

- A) Slope = $-\frac{6}{5}$; y-intercept = (0, 4.5)
B) Slope = -4.5; y-intercept = $\left(0, -\frac{6}{5}\right)$
C) Slope = $-\frac{6}{5}$; y-intercept = (0, -4.5)
D) Slope = $-\frac{6}{5}x$; y-intercept = (0, 4.5)

Answer: C

133) $f(x) = \frac{2}{3}x - 10$

- A) Slope = $\frac{2}{3}$; y-intercept = (0, -10)
B) Slope = -10; y-intercept = $\left(\frac{2}{3}, 0\right)$
C) Slope = $\frac{3}{2}$; y-intercept = (0, -11)
D) Slope = $\frac{1}{2}$; y-intercept = (0, 10)

Answer: A

134) $f(x) = 6$

- A) Slope = 6; y-intercept = (0, 6)
- B) Slope = 0; y-intercept = (0, 0)
- C) Slope = 0; y-intercept = (0, 6)
- D) Slope = 6; y-intercept = (0, 0)

Answer: C

135) $9x + 4f(x) = 47$

- A) Slope = $-\frac{4}{9}$; y-intercept = 0, 9
- B) Slope = $-\frac{9}{4}$; y-intercept = 0, 4
- C) Slope = $\frac{4}{9}$; y-intercept = 0, 9
- D) Slope = $\frac{9}{4}$; y-intercept = 0, 4

Answer: B

136) $2x - 3f(x) = -6$

- A) Slope = $-\frac{2}{3}$; y-intercept = (0, -2)
- B) Slope = $\frac{3}{2}$; y-intercept = (0, -2)
- C) Slope = $-\frac{3}{2}$; y-intercept = (0, 2)
- D) Slope = $\frac{2}{3}$; y-intercept = (0, 2)

Answer: D

137) $5x - 2f(x) + 9 = 0$

- A) Slope = $-\frac{5}{2}$; y-intercept = 0, -2
- B) Slope = $\frac{5}{2}$; y-intercept = 0, -2
- C) Slope = $-\frac{5}{2}$; y-intercept = 0, 2

D) Slope = $\frac{5}{2}$; y-intercept = 0,

Answer: D

Find the slope of the line containing the two given points.

138) (1, 9) and (3, 6)

A) $-\frac{2}{3}$

B) $\frac{15}{4}$

C) $-\frac{3}{2}$

D) $\frac{3}{2}$

Answer: C

139) (-5, 4) and (9, 8)

A) $\frac{7}{2}$

B) $-\frac{2}{7}$

C) $\frac{2}{7}$

D) 3

Answer: C

140) (-8, -5) and (3, -5)

A) $-\frac{10}{11}$

B) 2

C) Undefined

D) 0

Answer: D

141) (-10, -12) and (-14, 18)

A) $-\frac{15}{2}$

B) $\frac{15}{2}$

C) -

$\frac{1}{4}$

D) -

$\frac{2}{15}$ Answer: A

142) (-0.9,

10.3) and (-

16.3, -5.5)

A) $\frac{77}{79}$

B) $\frac{79}{77}$

C) $\frac{79}{77}$ -

D) -

$\frac{77}{79}$ Answer: B

143) $\left(-\frac{3}{7}, -\frac{4}{7}\right)$ and $4\left(\frac{3}{7}, -\frac{1}{7}\right)$

A) 1

B) 0

C) $\frac{1}{7}$

D) -1

Answer: A

144) (1968, 2) and (1978, 8) A) 0

B) $\frac{3}{10}$

C) $\frac{3}{5}$

D) $\frac{5}{3}$

Answer: C

145) (5, -9) and (5, -2)

A) -2 B)

Undefined

C) 7

D) -

$\frac{1}{2}$ Answer: B
 $\left(-\frac{1}{12}, \frac{3}{146}\right)$ and $\left(-\frac{1}{146}, -\frac{1}{12}\right)$

and, -

$\frac{5}{7}$ $\frac{5}{7}$

A) $\frac{7}{5}$

B) $\frac{7}{10}$

C) $\frac{5}{14}$

D) $\frac{5}{7}$

Answer: C

147) (5, -3) and (5, -5) A) Undefined B) 2

C) 0

D) -2

Answer: A

Find a linear function whose graph has the given slope and y-intercept.

148) Slope $-\frac{5}{8}$, y-intercept $\left(0, \frac{49}{8}\right)$

A) $f(x) = -\frac{5}{8}x + \frac{49}{8}$

B) $f(x) = -\frac{5}{8}x - \frac{49}{8}$

C) $f(x) = \frac{5}{8}x - \frac{49}{8}$

D) $f(x) = \frac{5}{8}x + \frac{49}{8}$

Answer: A

149) Slope $-\frac{4}{3}$, y-intercept (0, 9)

A) $f(x) = \frac{4}{3}x + 9$

B) $f(x) = \frac{4}{3}x - 9$

C) $f(x) = -\frac{4}{3}x + 9$

D) $f(x) = -\frac{4}{3}x - 9$

Answer: C

150) Slope $\frac{9}{5}$, y-intercept (0, -7)

A) $f(x) = \frac{9}{5}x + 7$

B) $f(x) = -\frac{9}{5}x + 7$

C) $f(x) = \frac{9}{5}x - 7$

$$D) f(x) = -\frac{9}{5}x - 7$$

Answer: C

151) Slope $\frac{1}{2}$, y-intercept (0, 1)

$$A) f(x) = \frac{1}{2}x - 1 \quad B) f(x) = -\frac{1}{2}x + 1$$

$$C) f(x) = -\frac{1}{2}x - 1$$

$$D) f(x) = \frac{1}{2}x + 1$$

Answer: D

152) Slope $-\frac{4}{5}$, y-intercept $\left(0, \frac{11}{5}\right)$

$$A) f(x) = \frac{4}{5}x - \frac{11}{5} \quad B) f(x) = -\frac{4}{5}x - \frac{11}{5}$$

$$C) f(x) = -\frac{4}{5}x + \frac{11}{5}$$

$$D) f(x) = \frac{4}{5}x + \frac{11}{5}$$

Answer: C

153) Slope $-\frac{2}{5}$, y-intercept (0, 2)

$$A) f(x) = \frac{2}{5}x + 2 \quad B) f(x) = -\frac{2}{5}x + 2$$

$$C) f(x) = -\frac{2}{5}x - 2$$

$$D) f(x) = \frac{2}{5}x - 2$$

Answer: B

154) Slope -8, y-intercept (0, -9)

$$A) f(x) = -8x + 8$$

$$B) f(x) = -8x - 9$$

$$C) f(x) = -8x + 9$$

$$D) f(x) = -9x - 8$$

Answer: B

155) Slope 3, y-intercept $\left(0, -\frac{3}{5}\right)$

A) $f(x) = 3x + \frac{3}{5}$

B) $f(x) = -\frac{3}{5}x - 3$

C) $f(x) = 3x - \frac{3}{5}$ D) $f(x) = -\frac{3}{5}x + 3$

Answer: C

Find the rate of change. Use appropriate units.

156)156)

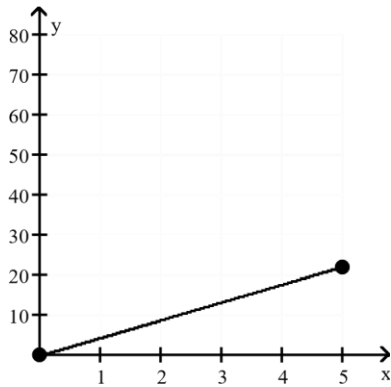

Distance Traveled in Miles

Number of Hours Spent Traveling

A) 4.4 miles per hour

B) 2.4 miles per hour

C) 0.4 miles per hour

D) 0.2 miles per hour

Answer: A

157)157)

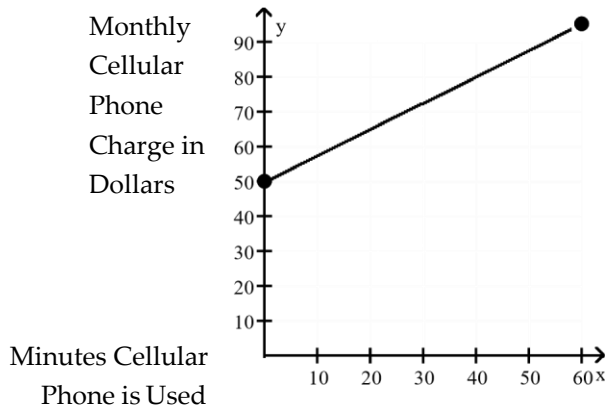

- A) \$0.11 per minute
- B) \$2.30 per minute
- C) \$1.33 per minute
- D) \$0.75 per minute

Answer: D

158)158)

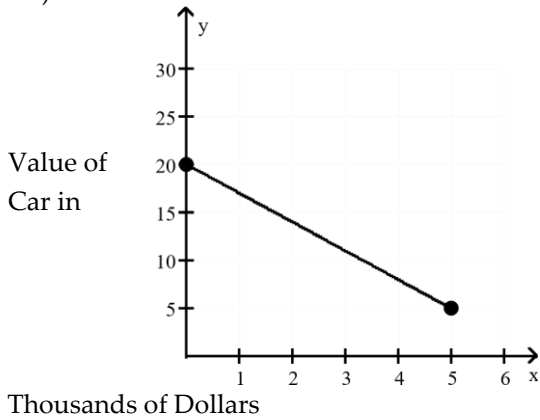

- A) -\$3 thousand per year
- B) \$4 thousand per year
- C) -\$4 thousand per year
- D) \$3 thousand per year

Answer: A

159) The line graph represents the gallons of water in a swimming pool after x hours. There is a pump that can either add or remove water from the pool. Find the rate of change from $(0, 98)$ to $(2, 298)$.

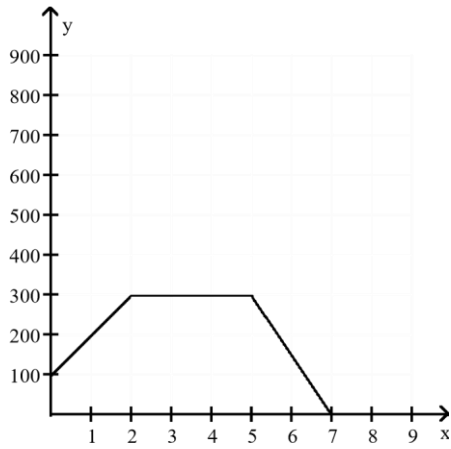

- A) 100 gallons per hour B) 50 gallons per hour
 C) 200 gallons per hour
 D) -200 gallons per hour

Answer: A

160) The line graph represents the gallons of water in a swimming pool after x hours. There is a pump that can either add or remove water from the pool. Find the rate of change from $(2, 413)$ to $(5, 413)$.

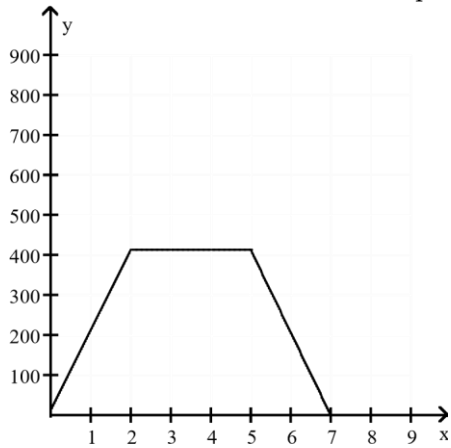

- A) 0 gallons per hour B) 1 gallon per hour
 C) -1 gallon per hour
 D) 2 gallons per hour

Answer: A

161) The line graph represents the gallons of water in a swimming pool after x hours. There is a pump that can either add or remove water from the pool. Find the rate of change from $(5, 443)$ to $(7, 0)$.

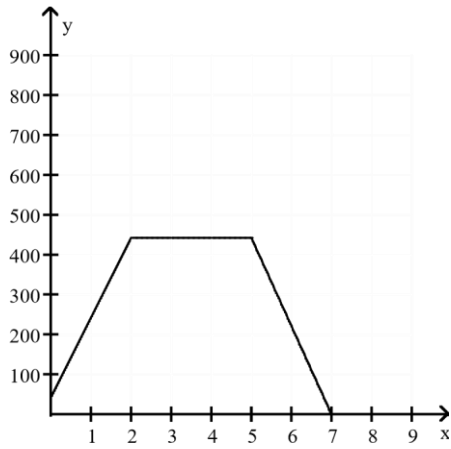

- A) 0 gallons per hour
- B) $-\frac{543}{2}$ gallons per hour
- C) $\frac{443}{2}$ gallons per hour
- D) $-\frac{443}{2}$ gallons per hour

Answer: D

162) The line graph represents the gallons of water in a swimming pool after x hours. There is a pump that can either add or remove water from the pool. Find the rate of change from $(5, 296)$ to $(9, 0)$.

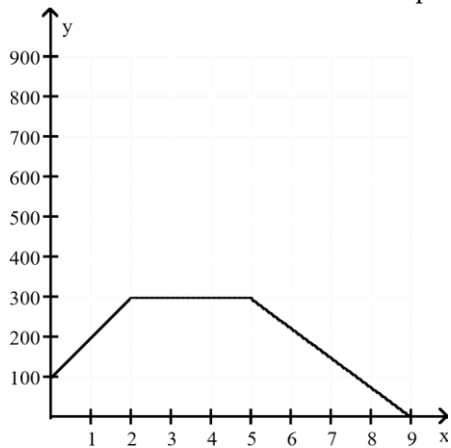

- A) 74 gallons per hour
- B) - 74 gallons per hour
- C) - 148 gallons per hour
- D) 148 gallons per hour

Answer: B

163) The line graph represents the height of the sand in an hourglass (in mm) after x minutes. Find the rate of change from $(10, 7.5)$ to $(55, 41.25)$.

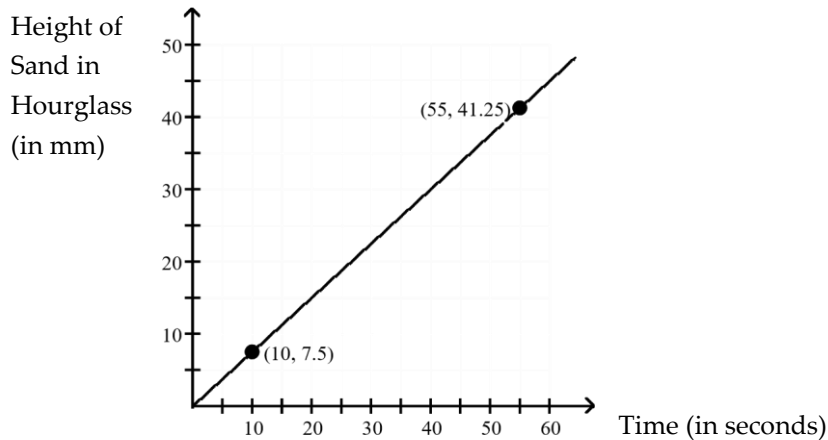

- A) .75 mm per second
 - B) 1 mm per second
 - C) .85 mm per second
 - D) 1.3 mm per second
- Answer: A

Solve the problem.

- 164) The rate of return of certain investments increases as the risk factor of the investment increases. An investment with a risk factor of 2 has a rate of return of 5.0%. An investment with a risk factor of 16 has a rate of return of 15.0%. What is the average rate of return per unit of risk? Round to the nearest hundredth if necessary.
- A) 0.85% per unit risk
 - B) 0.71% per unit risk
 - C) 1.40% per unit risk
 - D) 1.18% per unit risk
- Answer: B
- 165) A deep sea diving bell is being lowered at a constant rate. After 12 minutes, the bell is at a depth of 400 feet. After 55 minutes the bell is at a depth of 1400 feet. What is the average rate of lowering per minute? Round to the nearest tenth if necessary.
- A) 23.3 ft per minute
 - B) 25.5 ft per minute
 - C) 18.2 ft per minute
 - D) 0.04 ft per minute
- Answer: A
- 166) The cost of manufacturing a molded part is related to the quantity produced during a production run. When 100 parts are produced, the cost is \$300. When 400 parts are produced, the cost is \$2100. What is the average cost per part?
- A) \$4.50 per part
 - B) \$6.00 per part
 - C) \$0.17 per part
 - D) \$7.00 per part
- Answer: B

167) A cross-country skier reaches the 11-km mark of a race 40 min after reaching the 2-km mark. Find the speed of the skier.

- A) 9 km/hour
- B) $\frac{33}{2}$ km/hour
- C) 18 km/hour
- D) $\frac{27}{2}$ km/hour

Answer: D

168) In 1980, the population of a city was 5.3 million. By 1992 the population had grown to 6.7 million. Find the rate at which the population of the city was growing.

- A) $\frac{7}{45}$ million per year
- B) $\frac{1}{10}$ million per year
- C) $\frac{67}{120}$ million per year
- D) $\frac{7}{60}$ million per year

Answer: D

Match the graph with the most appropriate sentence.

169)169)

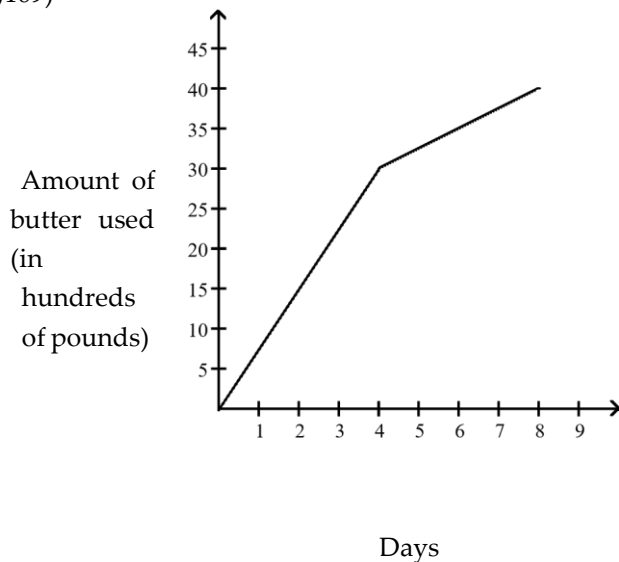

- A) The pounds of butter used continued to rise after day 4 but at a slower rate.
- B) The pounds of butter used continued to rise after day 4 at the same rate.
- C) The pounds of butter used remained level after day 4.
- D) The pounds of butter used continued to rise after day 4 but at a faster rate.

Answer: A

170)170)

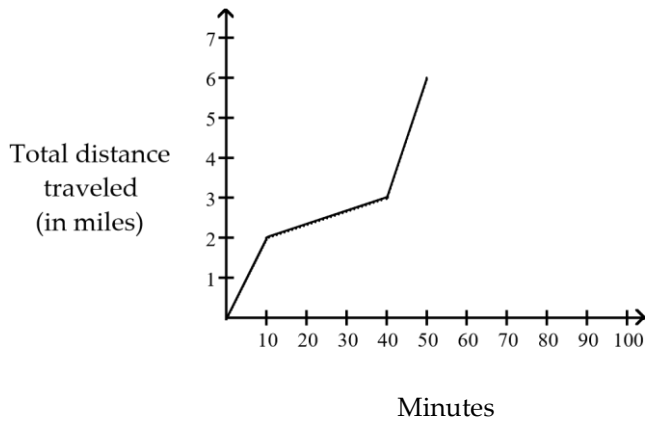

- A) During a preseason workout, Rico biked for 2 miles, walked for 2 miles, then took a 3 mile bus ride back to the park.
- B) During a preseason workout, Rico biked for 3 miles, walked for 1 mile, then took a 3 mile bus ride back to the park.
- C) During a preseason workout, Rico biked for 2 miles, walked for 1 mile, then took a 4 mile bus ride back to the park.
- D) During a preseason workout, Rico biked for 2 miles, walked for 1 mile, then took a 3 mile bus ride back to the park.

Answer: D

171)171)

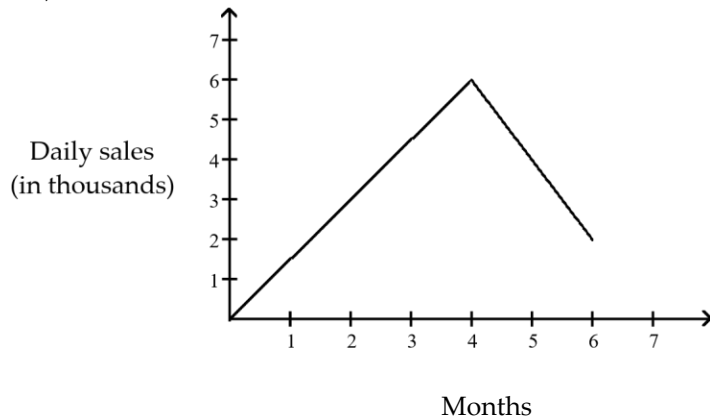

- A) After the 4th month, the sales rate became level.
- B) After the 4th month, sales decreased but rose again on the 5th month.
- C) After the 4th month, sales continued to rise but at a slower rate.
- D) After the 4th month, sales decreased.

Answer: D

172)172)

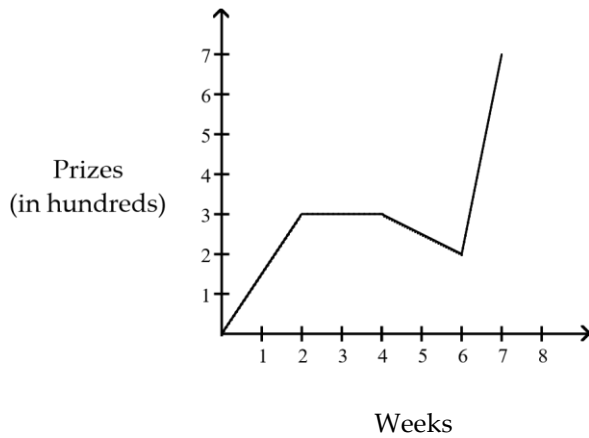

- A) The rate at which prizes were given away remained level during the fifth and sixth week.
- B) The rate at which prizes were given away grew faster during the seventh week than any other period of time.
- C) The rate at which prizes were given away decreased during the third and fourth weeks faster than any other period of time.
- D) The rate at which prizes were given away grew faster during the second than any other period of time.

Answer: B

173)173)

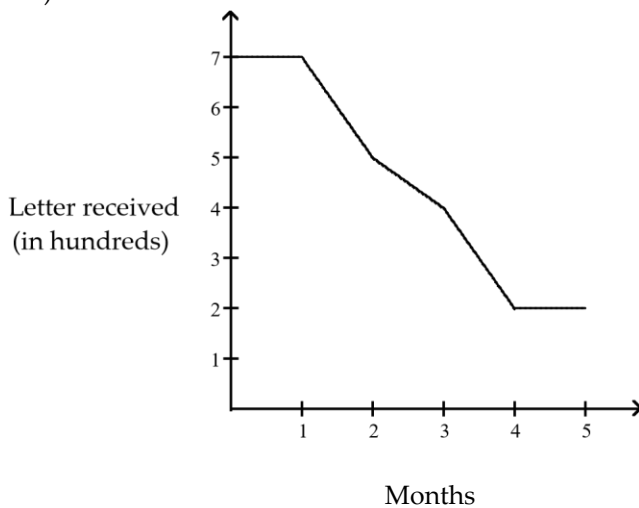

- A) The rate at which letters were received never decreased.
- B) The rate at which letters were received never increased.
- C) The rate at which letters were received increased from day 4 to day 5.
- D) The rate at which letters were received decreased from day 4 to day 5.

Answer: B

174)174)

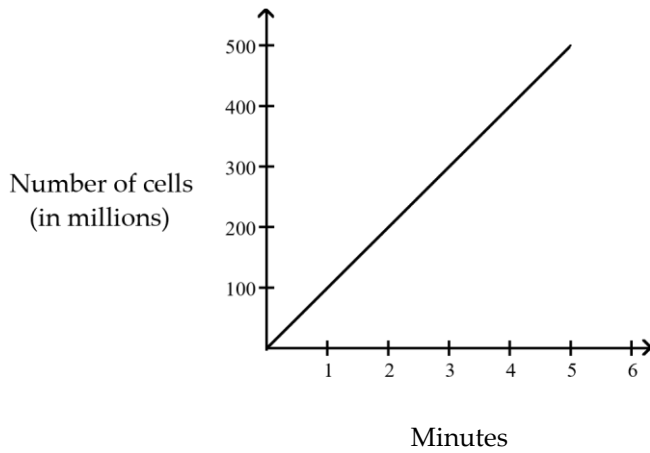

- A) The number of cells decreased.
 - B) The number of cells decreased at a constant rate.
 - C) The number of cells increased at a constant rate.
 - D) The number of cells stayed the same.
- Answer: C

175)175)

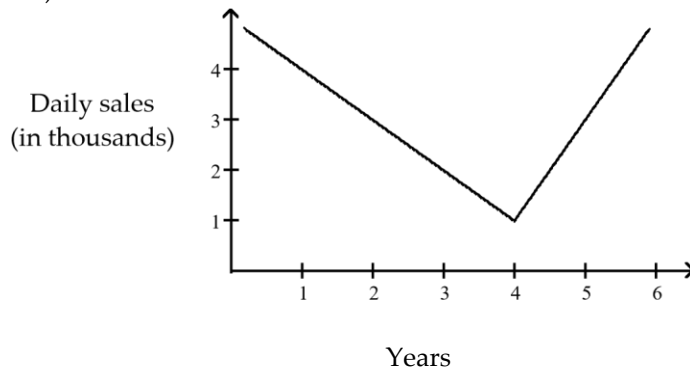

- A) After four years, daily sales decreased at half the rate that they previously increased.
- B) After four years, daily sales decreased at twice the rate that they previously increased.
- C) After four years, daily sales increased at half the rate that they previously decreased.
- D) After four years, daily sales increased at twice the rate that they previously decreased.

Answer: D

176)176)

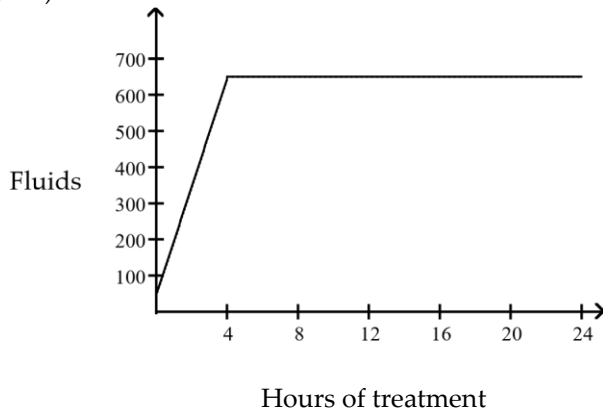

- A) Fluids were provided at an increasing rate during the first four hours of treatment and then were provided at a constant rate.
- B) Fluids were provided at an increasing rate during the first four hours of treatment and then were discontinued.
- C) Fluids were provided at a constant rate during the first four hours of treatment and then were discontinued.
- D) Fluids were provided at a constant level during the first four hours of treatment and then were discontinued. Answer: C

This model is of the form $f(x) = mx + b$. Determine what m and b signify.

- 177) The cost, in dollars, of retaining the services of a computer repairman in Anchorville is given by $C(x) = 70x + 32$, where x is the number of hours worked.
- A) 32 signifies the hourly rate, and 70 signifies the overhead charge.
 - B) 102 signifies the cost for an on-site inspection.
 - C) -70 signifies the hourly rate, and 32 signifies the travel cost.
 - D) 70 signifies the hourly rate, and 32 signifies the overhead charge.

Answer: D

- 178) The cost, in dollars, of cellular phone service with Econo-phone is given by $C(x) = 0.52x + 33.20$, where x is the number of minutes used in one month.
- A) 0.52 signifies the hourly phone rent, and 33.20 signifies the cost of the hardware.
 - B) 0.52 signifies the cost per minute, and 33.20 signifies the monthly service charge.
 - C) 33.20 signifies the total phone bill, and 0.52 signifies the number of minutes used.
 - D) 33.20 signifies the cost per minute, and 0.52 signifies the monthly service charge.

Answer: B

- 179) The value, in dollars, of a particular KX37B computer is given by $V(x) = -636.29x + 7113$, where x is the number of years the computer has been in existence.
- A) -636.29 signifies the hourly cost of repairs, and 7113 signifies the cost of software.
 - B) -636.29 signifies the amount of depreciation in one year, and 7113 signifies the initial cost. C) 7113 signifies the amount of depreciation in one year, and -636.29 signifies the initial cost.
 - D) -636.29 signifies the number of computers owned, and 7113 signifies the cost of electricity.

Answer: B

- 180) The cost, in dollars, of a one-day car rental is given by $C(x) = 28 + 0.19x$ where x is the number of miles driven. A) \$28 is the cost per day to rent the car and \$0.19 is the cost per mile. B) \$0.19 is the cost per day to rent the car and \$28 is the cost per mile.
- C) \$28 is the cost per day to rent the car and \$19 is the extra cost for unlimited miles.
 - D) \$19 is the cost per day to rent the car and \$0.28 is the cost per mile.

Answer: A

- 181) The population, in millions, of a city t years after 1990 is given by $P(t) = 2.7 + 0.10t$.
- A) 2.7 million is the population of the city in 1991 and 2.8 million is the population in 1992.
 - B) 0.10 million is the population of the city in 1990 and 2.7 million is the increase per year in the population .

- C) 2.7 million is the population of the city in 1990 and 0.10 million is the decrease per year in the population .
D) 2.7 million is the population of the city in 1990 and 0.10 million is the increase per year in the population .

Answer: D

Solve the problem.

- 182) Computer Incorporated sells computer systems. The company profit is given by the function $f(x) = 140x - 2000$, for $x \geq 20$, where x is the number of computer systems sold. Interpret the slope of the graph of f as a rate of change.
- A) The company profit decreases by \$145 for each computer system that is sold.
B) The company profit increases by \$100 for each computer system that is sold.
C) The company profit increases by \$145 for each computer system that is sold. D) The company profit increases by \$140 for each computer system that is sold.

Answer: D

- 183) The value, in dollars, of a copy machine is given by the function $f(x) = -370x + 5700$, where x is the number of years that have passed since the machine was purchased. Interpret the slope of the graph of f as a rate of change.
- A) The copy machine decreases in value by \$370 each year.
B) The copy machine increases in value by \$185 each year.
C) The copy machine increases in value by \$370 each year.
D) The copy machine decreases in value by \$185 each year.

Answer: A

- 184) The value, in dollars, of a copy machine is given by the function $f(x) = -380x + 761,500$, where x is the year and $1990 \leq x \leq 2000$. What is the value of the copy machine in 1998?
- A) \$1880
B) \$2260
C) \$1500
D) \$2640

Answer: B

- 185) From 1992 to 1999, the number of automobile vehicle tags purchased in a certain city can be modeled by $f(x) = 76(x - 1992) + 1085$. Find the number of vehicle tags purchased in 1992.
- A) 1085
B) 10,850
C) 0
D) 1185

Answer: A

- 186) The cost P , in dollars, of having a dinner party catered by Elaine's Kosher Catering Company can be approximated by the function $P(d) = 45 + 12p$, where p is the number of people attending the party. The banquet hall where the dinner will be located can hold no more than 150 people. Find the domain of the function.

- A) $\{x \mid 7 \leq x \leq 55\}$
- B) $\{x \mid 0 \leq x \leq 150\}$
- C) $\{x \mid x \text{ is a real number}\}$ D) $\{x \mid x \leq 150\}$

Answer: B

187) The cost C , in dollars, of renting a car for a week from from Pricebusters Rent-A-Car can be approximated by the function $C(m) = 0.11m + 340$, where m is the number of miles the car is driven. Find the domain of the function.

- A) $\{x \mid x \geq 0\}$
- B) $\{x \mid x \leq 0.11\}$
- C) $\{x \mid x \text{ is a real number}\}$ D) $\{x \mid x \geq 340\}$

Answer: A

188) For children aged 5 to 15 years, the number of hours watching cartoons per week can be estimated by the function $H(s) = -1.1(s - 5) + 13$, where s is the age of the child. Find the domain of the function. A)

- {x x is a real number}
- B) $\{x \mid 1.1 \leq x \leq 13\}$
- C) $\{x \mid 2 \leq x \leq 13\}$
- D) $\{x \mid 5 \leq x \leq 15\}$

Answer: D

189) The average price for a gallon of milk from 1990 to 2000 can be approximated by $P(x) = .102(x - 1990) + 1.87$, where x is the year. Evaluate $P(1998)$ and interpret the result.

- A) $P(1998) = 2.69$; the average price of a gallon of milk in 1998 was \$2.69 more than in 1990.
- B) $P(1998) = 2.78$; the average price of a gallon of milk in 1998 was \$2.78.
- C) $P(1998) = 2.69$; the average price of a gallon of milk in 1998 was \$2.69. D) $P(1998) = 1.95$; the average price of a gallon of milk in 1998 was \$1.95.

Answer: C

Find the slope of the line.

190) $4x + 5y = 27$

- A) $-\frac{5}{4}$
- B) $\frac{5}{4}$
- C) $\frac{4}{5}$
- D) $-\frac{4}{5}$

Answer: D 191) -

$5y = -2x - 19$

- A) $\frac{5}{2}$

B) $\frac{2}{5}$

C) - $\frac{2}{5}$ - $\frac{5}{2}$

Answer: B

192) $4x - 5y = 28$

A) - $\frac{5}{4}$

B) $\frac{4}{5}$

C) - $\frac{4}{5}$

D) $\frac{5}{4}$

Answer: B

193) $14x - 12 = 12$

A) Undefined

B) -12

C) 0 D) 14

Answer: A

194) $20y + 2 = 6$

A) 20

B) 0

C) 2

D) Undefined

Answer: B

195) $3y - 4 = 5x$

A) 3

B) $\frac{5}{3}$

C) 5

D) $\frac{4}{3}$

Answer: B

196) $12 - 6x = 8 + 9x$

A) 0 B) 15

C) $\frac{15}{4}$

D) Undefined

Answer: D

197) $2y - 8 = 7 + x$

- A) 1 B) $\frac{1}{2}$ C) 2

D) $\frac{15}{2}$ Answer: B

198) $4y - 2x = 7 + 3y - 2x$

- A) 0 B) 1
C) Undefined
D) 7

Answer: A

199) $9x - 6y = 7x + 5$

- A) 2

- B) 3

C) $\frac{1}{3}$ D) $-\frac{5}{6}$ Answer: C

Graph.

200) $y = 3$

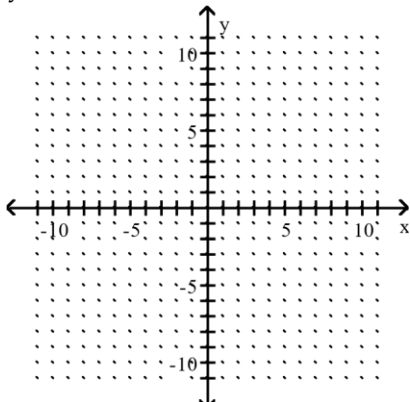

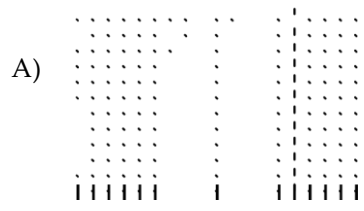

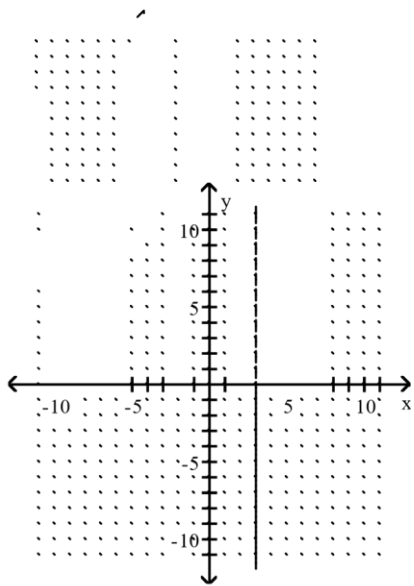

B)

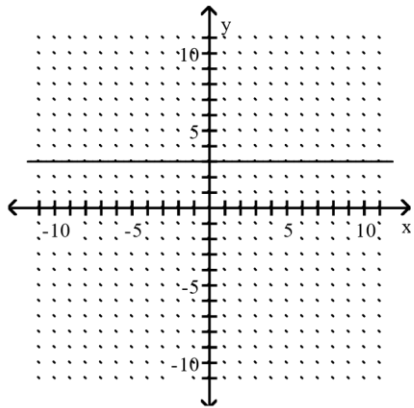

C)

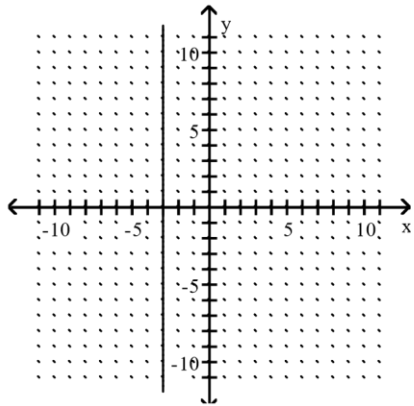

D)

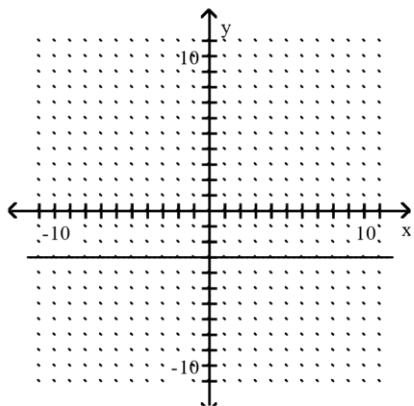



Answer: B

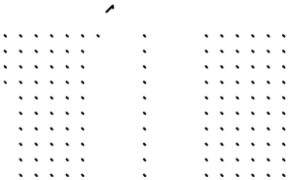

201) $x = 1$

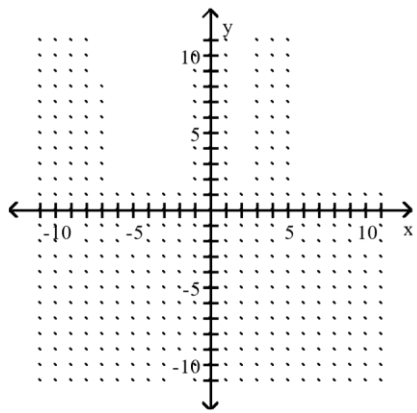

A)

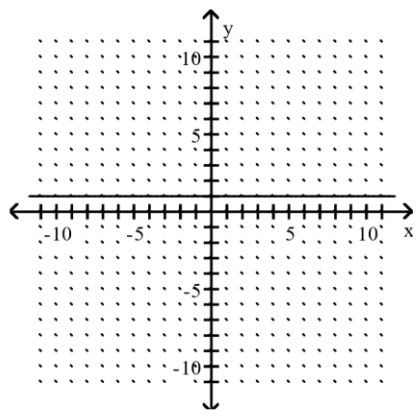

B)

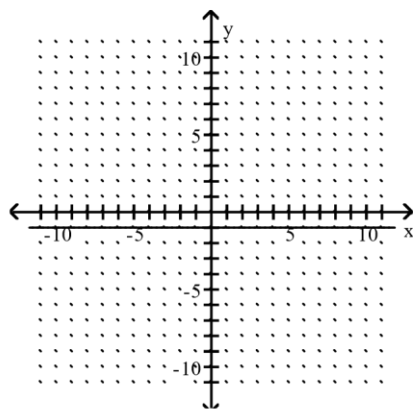

C)

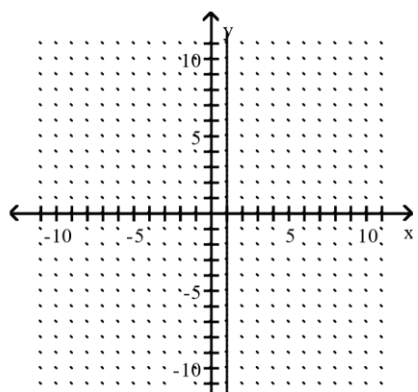

D)

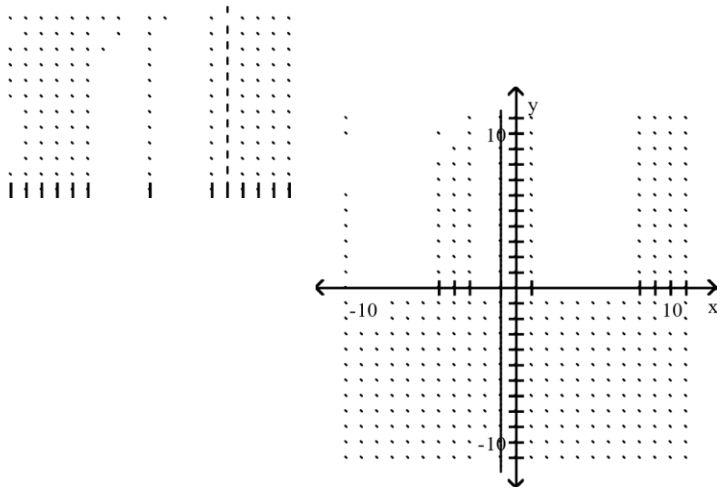

Answer: C
202) $y + 3 = 0$

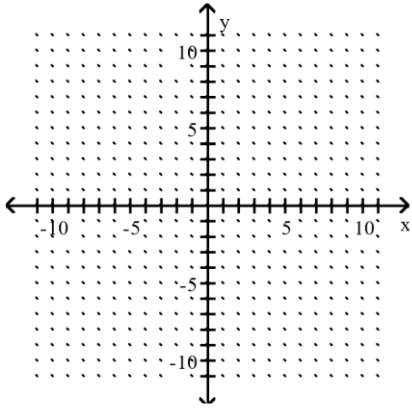

A)

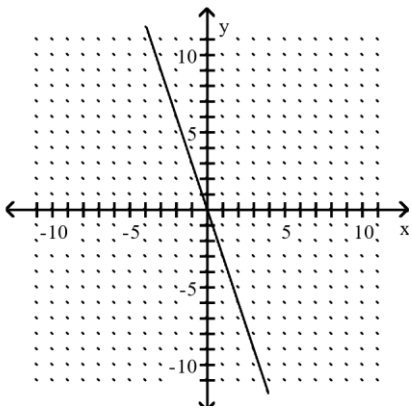

B)

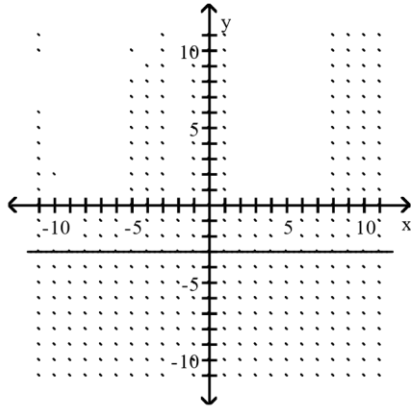
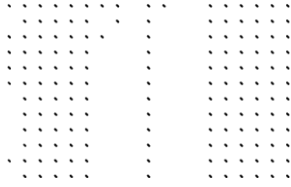

C)

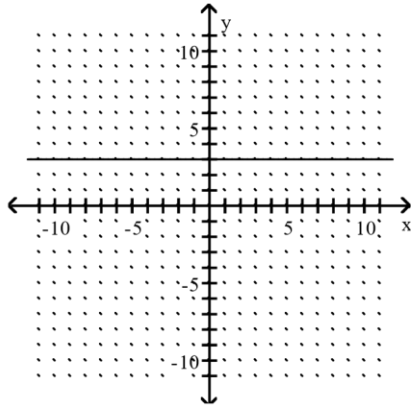

D)

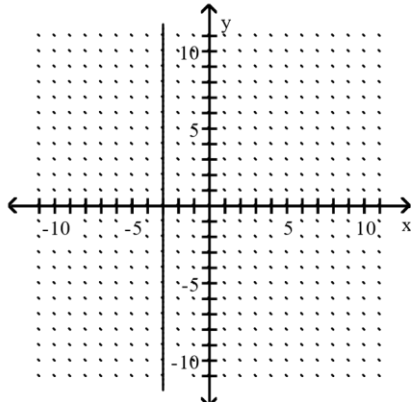

Answer: B

203) $3x = 12$

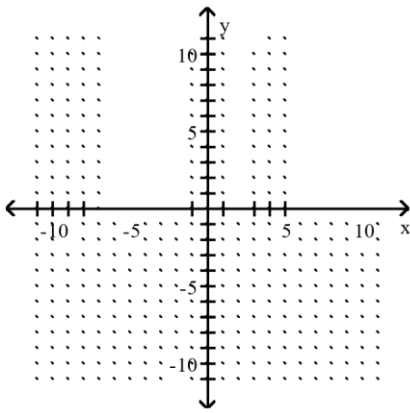

A)

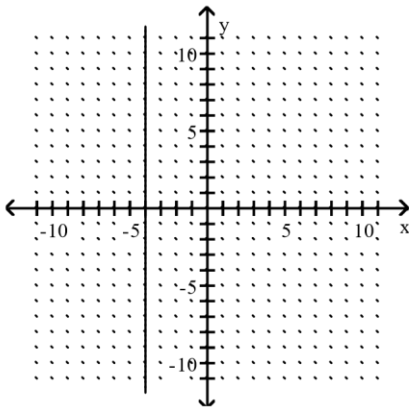

B)

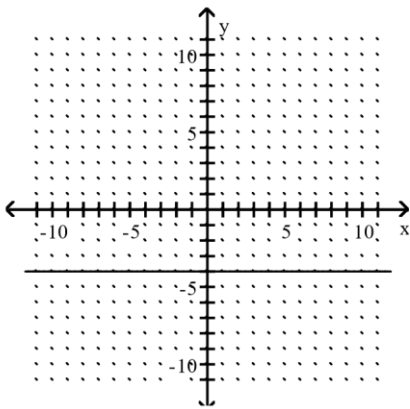

C)

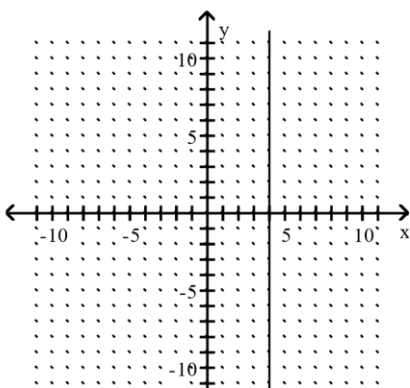

D)

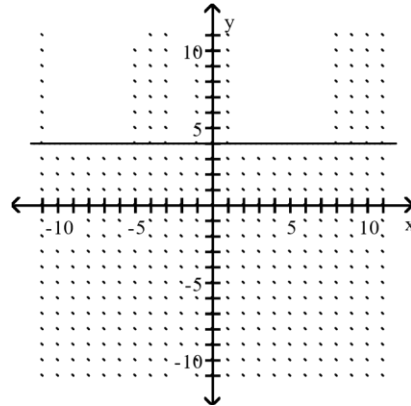
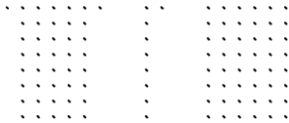

Answer: C

$$\frac{1}{7}(204) x =$$

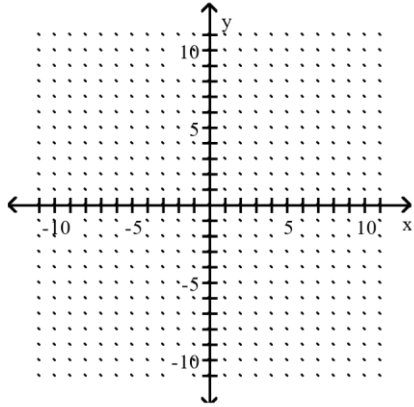

A)

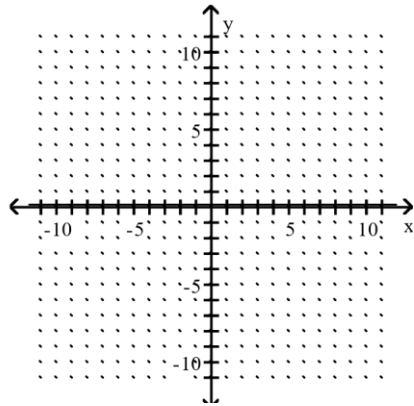

B)

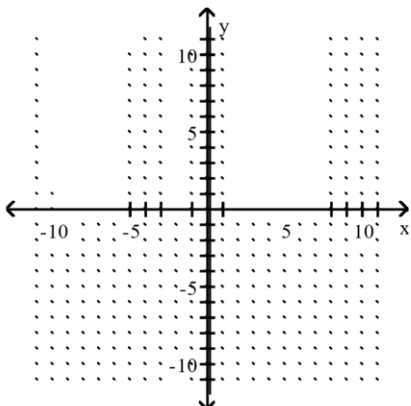
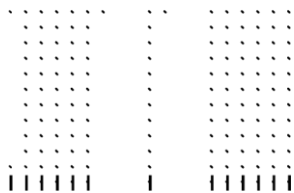

C)

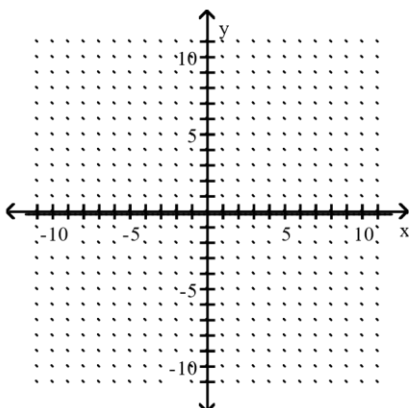

D)

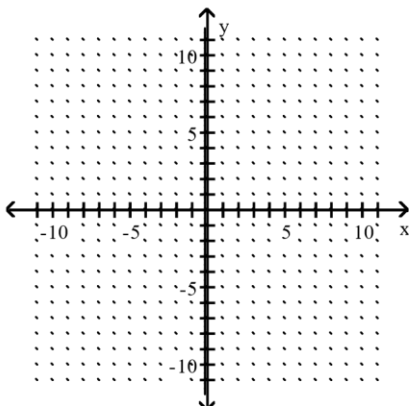

Answer: B

205) $-6 \cdot f(x) = -8$

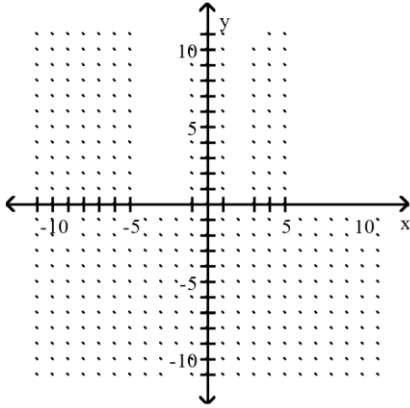

A)

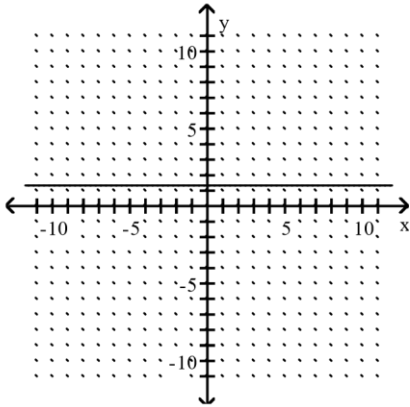

B)

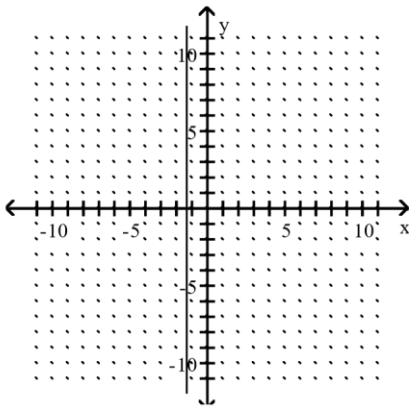

C)

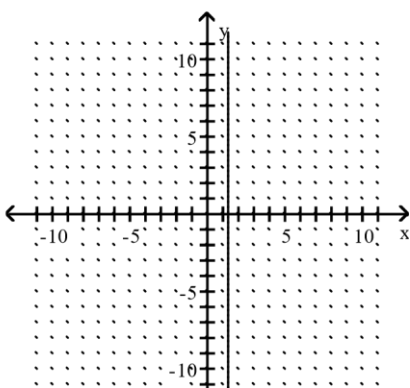

D)

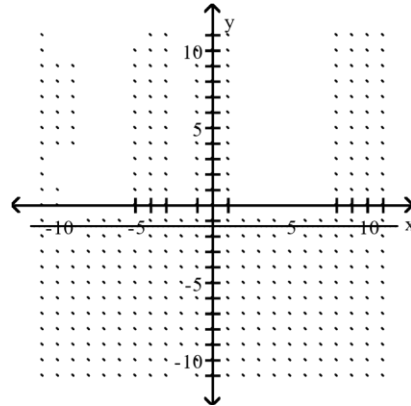

Answer: A

206) $-7 - 5 \cdot f(x) = 0$

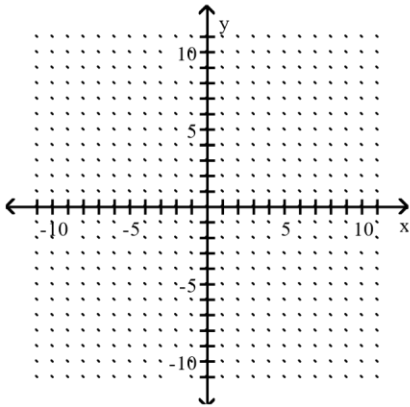

A)

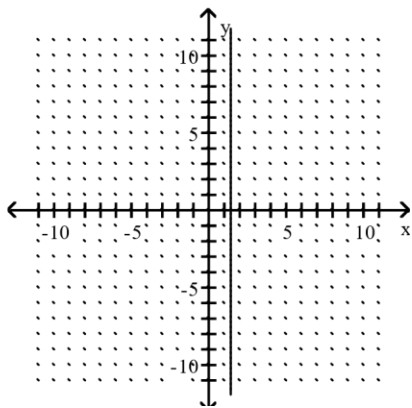

B)

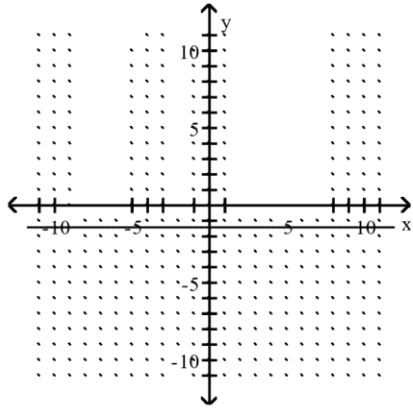
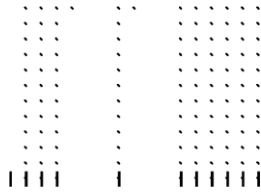

C)

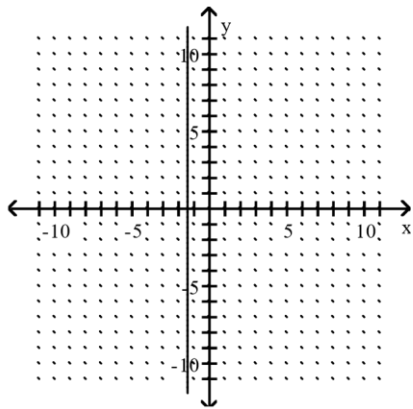

D)

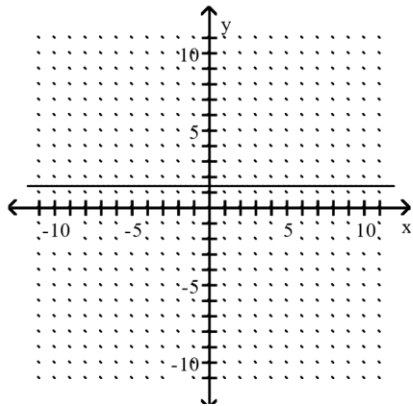

Answer: B

207) $-4x - 5 = 0$

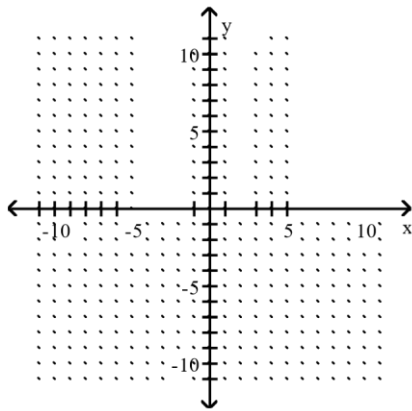

A)

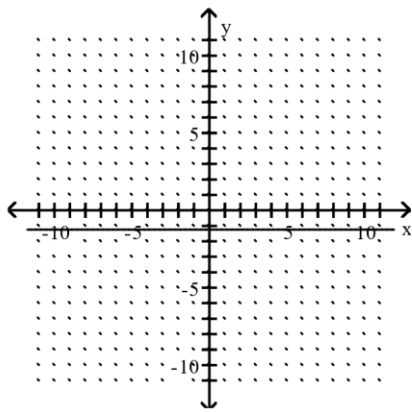

B)

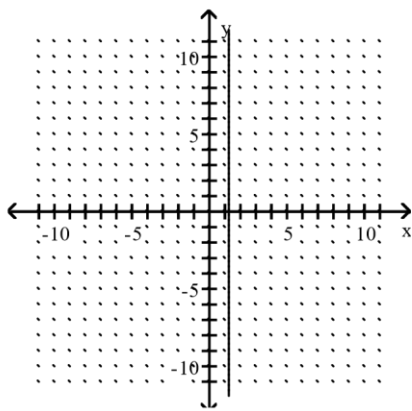

C)

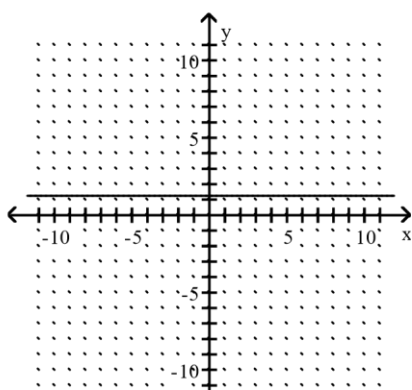

D)

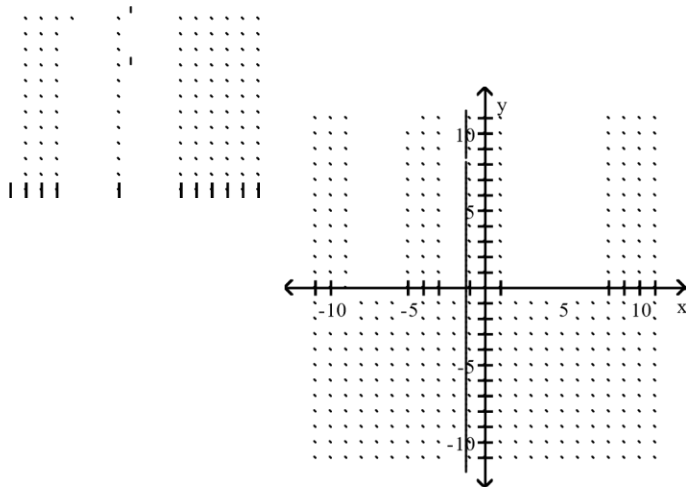

Answer: D

208) $2 \cdot f(x) + 4x = 2 + 4x$

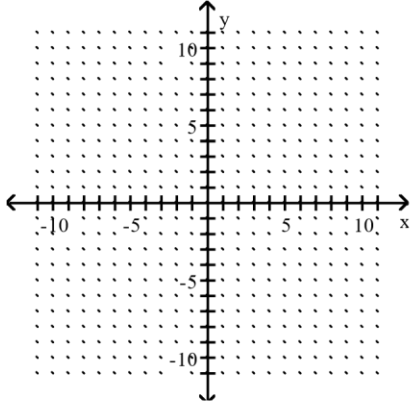

A)

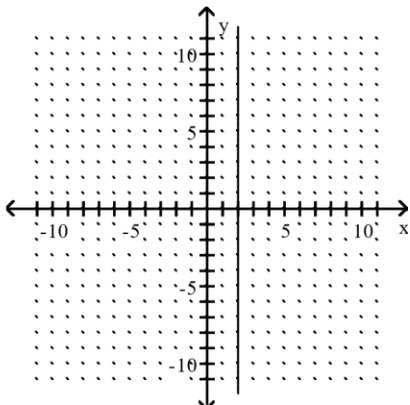

B)

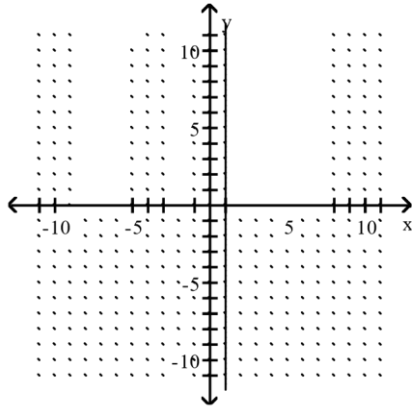
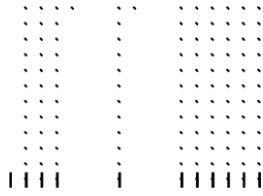

C)

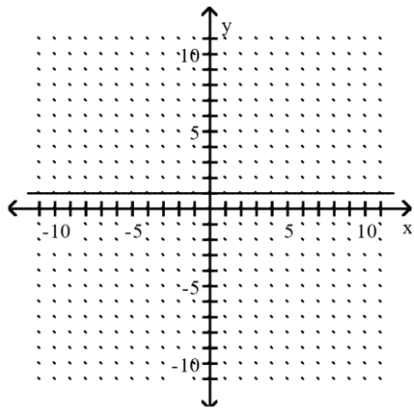

D)

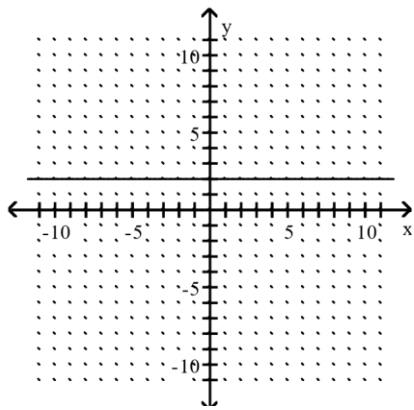

Answer: C

209) $2x - 7y + 6 = -7y$

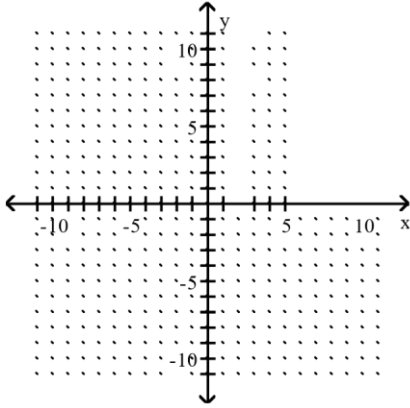

A)

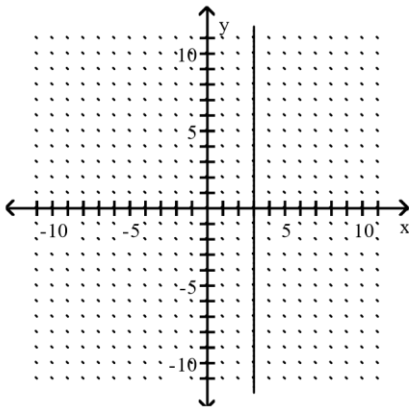

B)

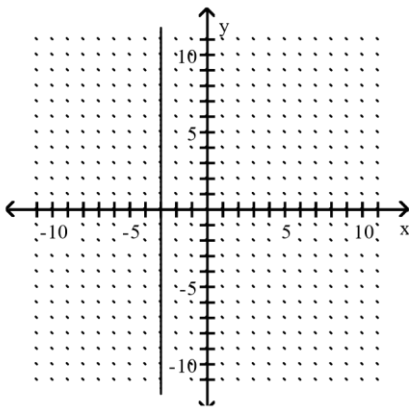

C)

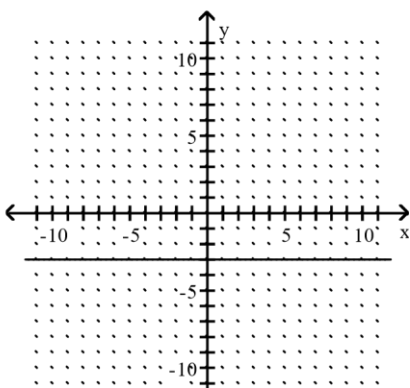

D)

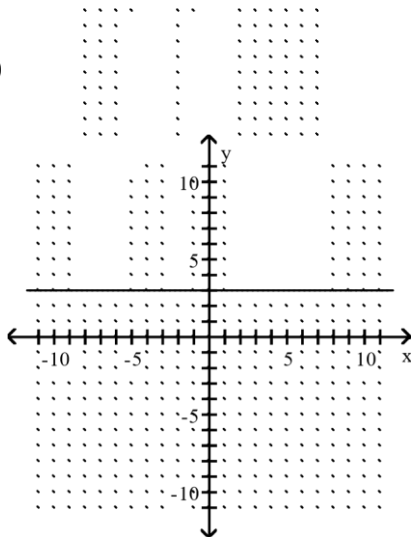

Answer: B

Find the y- and x-intercepts for the equation. Then graph the equation.

210) $6y - 3x = -9$

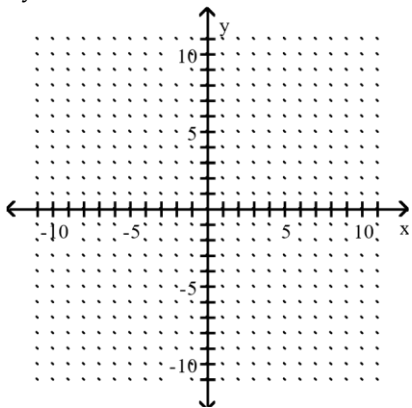

A) $(0, \frac{3}{2}); (-3, 0)$

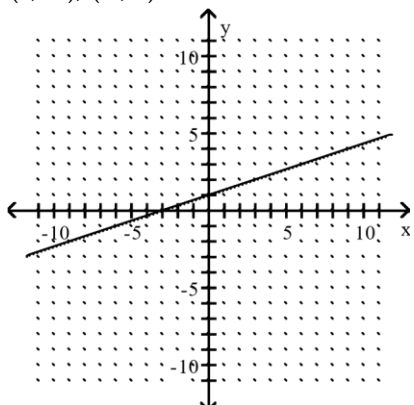

B) $(0, \frac{3}{2}); (3, 0)$

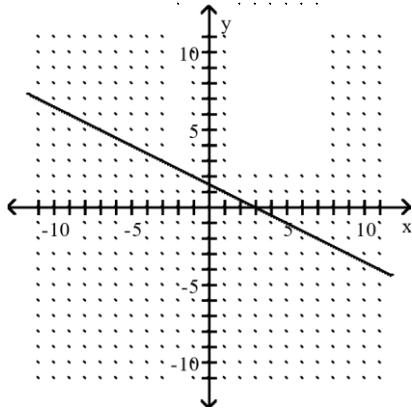

C) $(0, -\frac{3}{2}); (-3, 0)$

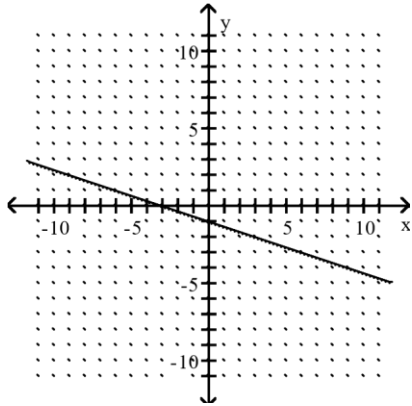

D) $(0, -\frac{3}{2}); (3, 0)$

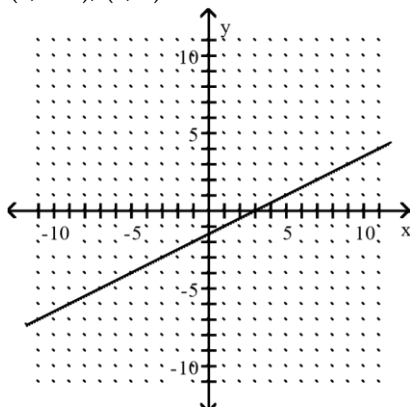

Answer: D

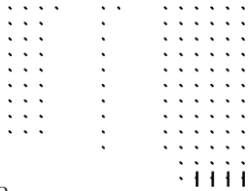

211) $-2x - 8y = 8$

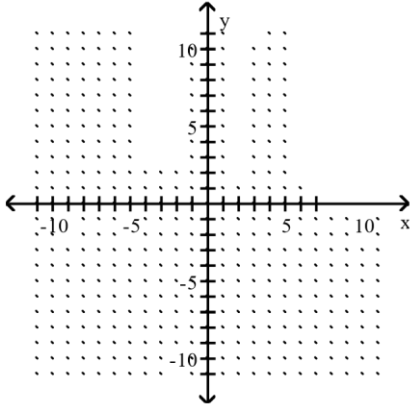

A) $(0, 1); (4, 0)$

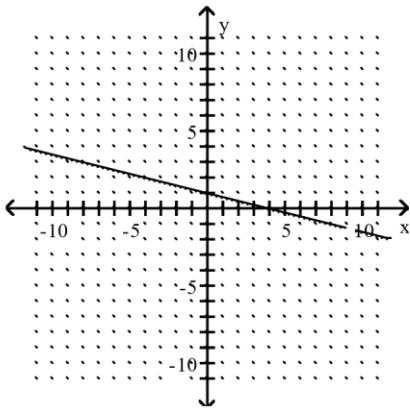

B) $(0, 1); (-4, 0)$

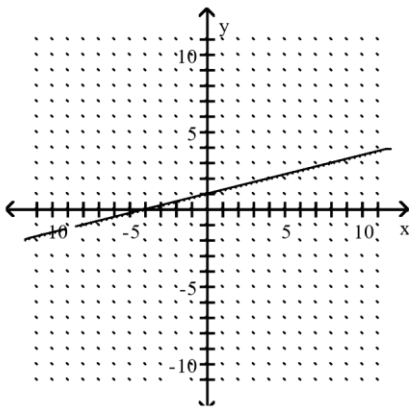

C) $(0, -1); (4, 0)$

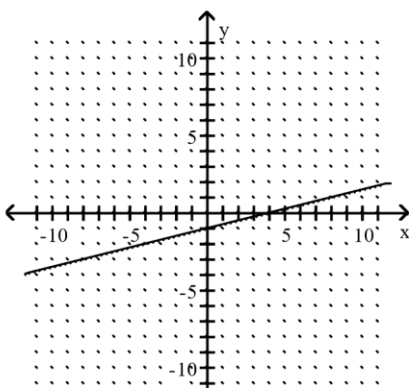

D) $(0, -1); (-4, 0)$

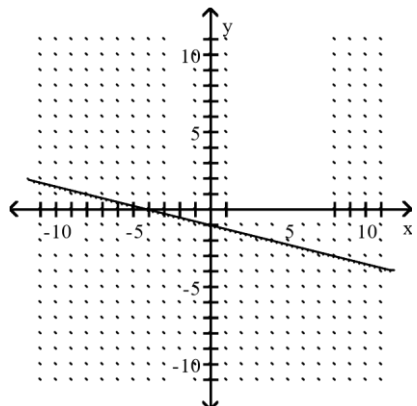
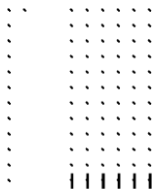

Answer: D
212) $4x - 8y = 16$

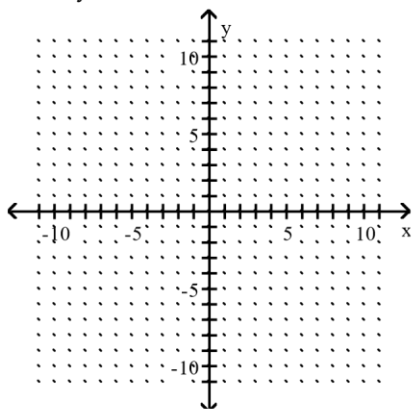

A) $(0, -2); (-4, 0)$

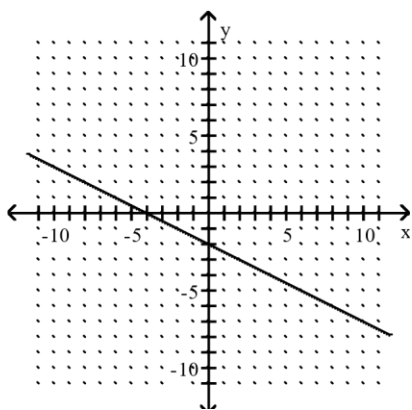

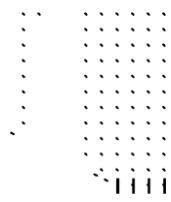

B) $(0, 2); (4, 0)$

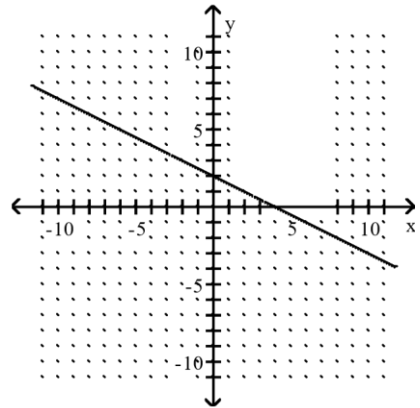

C) $(0, 2); (-4, 0)$

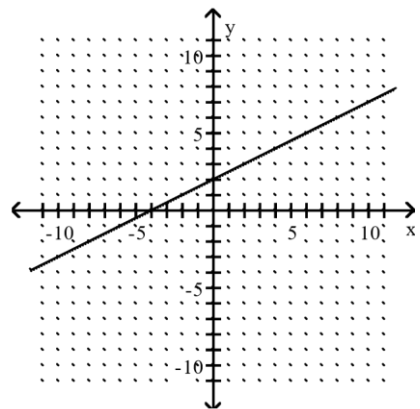

D) $(0, -2); (4, 0)$

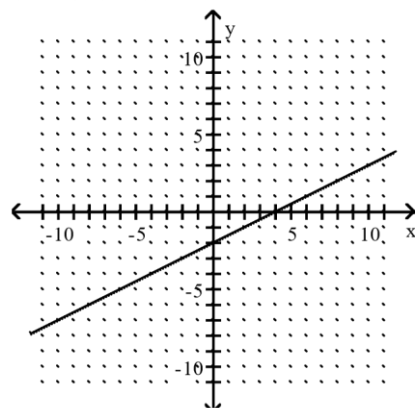

Answer: D

213) $3x - 12y = 0$

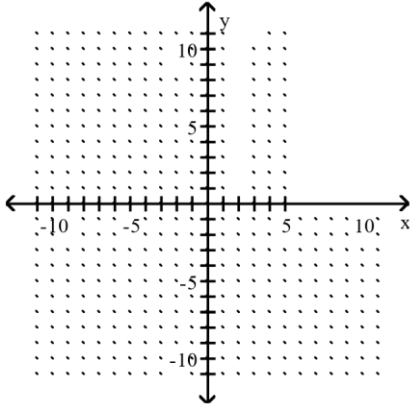

A) $(0, 0); (0, 0)$

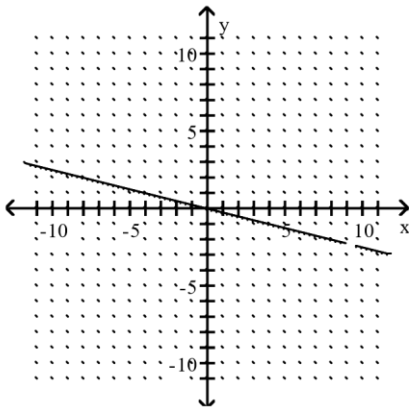

B) $(0, 0); (0, 0)$

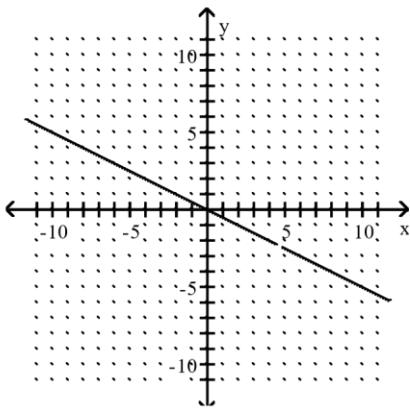

C) $(0, 0); (0, 0)$

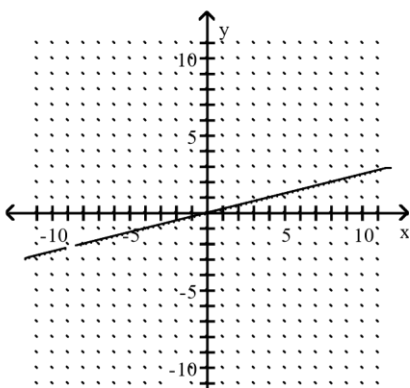

D) $(0, 0); (0, 0)$

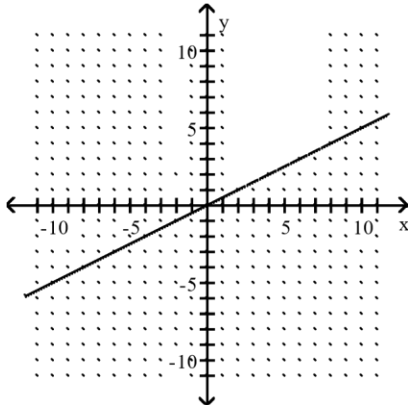

Answer: C

214) $3x - 6 = y$

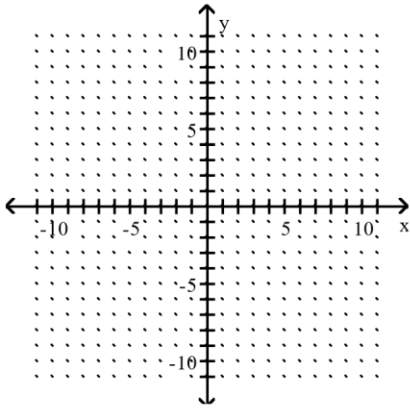

A) $(0, 2); (-6, 0)$

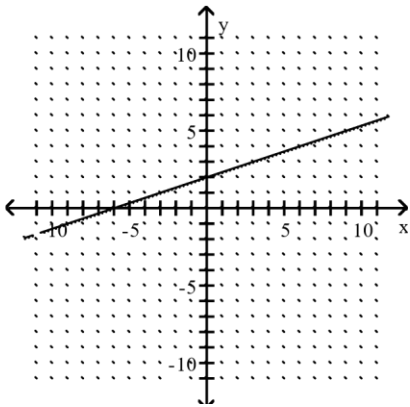

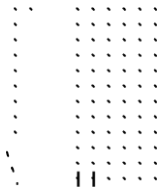

B) $(0, -6); (-2, 0)$

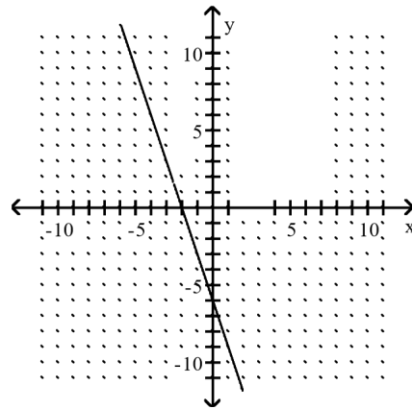

C) $(0, -2); (-6, 0)$

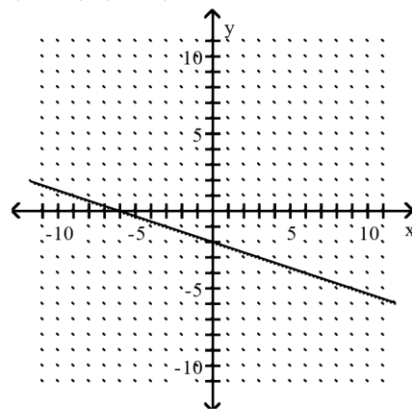

D) $(0, -6); (2, 0)$

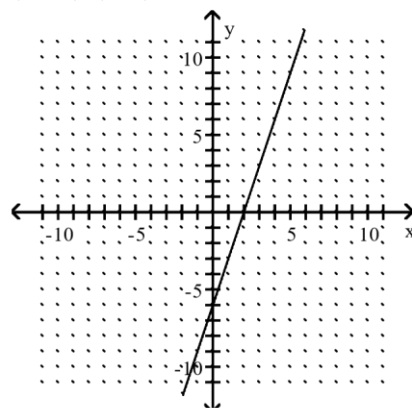

Answer: D

215) $f(x) = -5 - 6x$

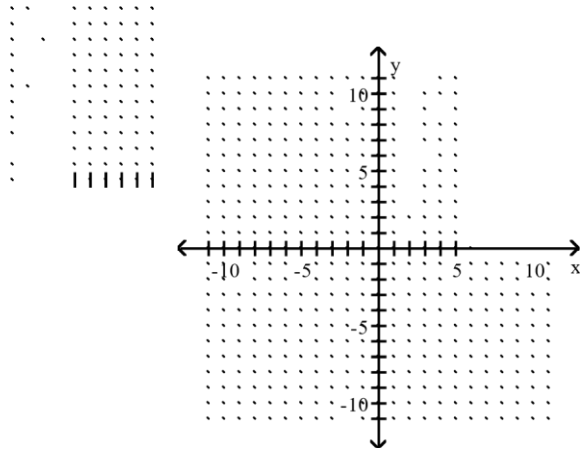

A) $(0, -\frac{5}{6}); (-5, 0)$

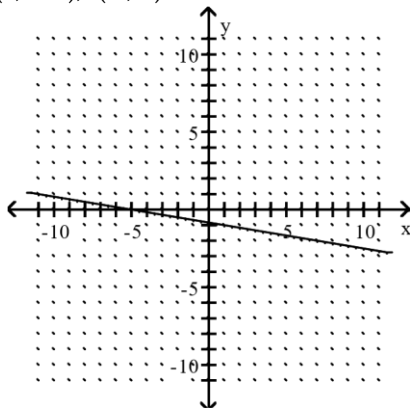

B) $(0, -5); (-\frac{5}{6}, 0)$

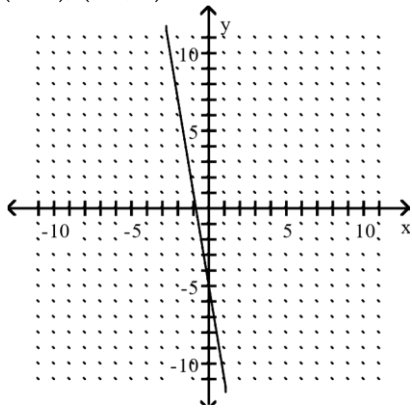

$$\frac{5}{6}$$

C) $(0, -5); (, 0)$

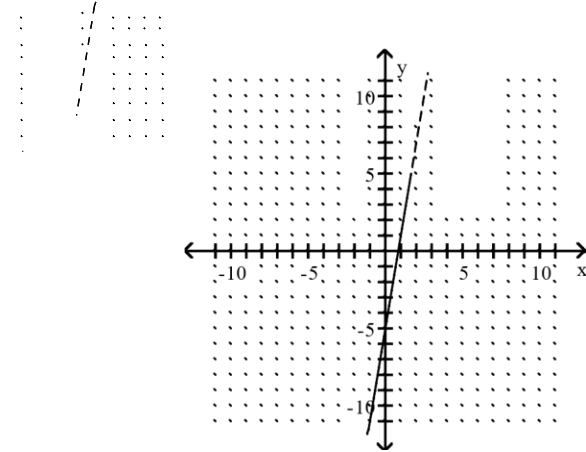

D) $(0, \frac{5}{6}); (-5, 0)$

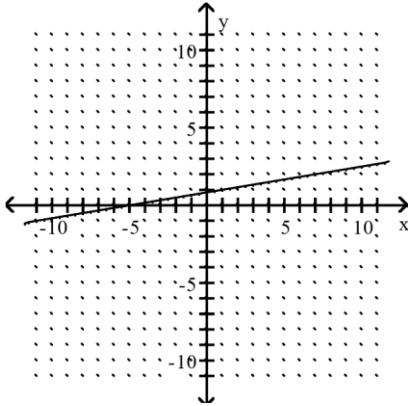

Answer: B

216) $8y = -24 + 3x$

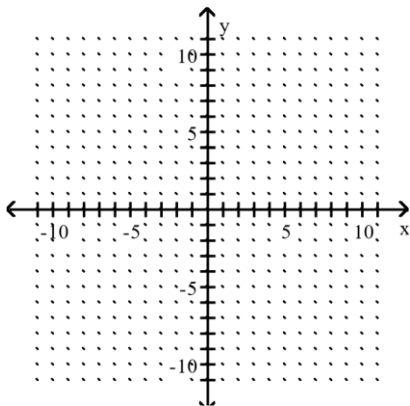

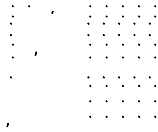

A) $(0, 8); (-3, 0)$

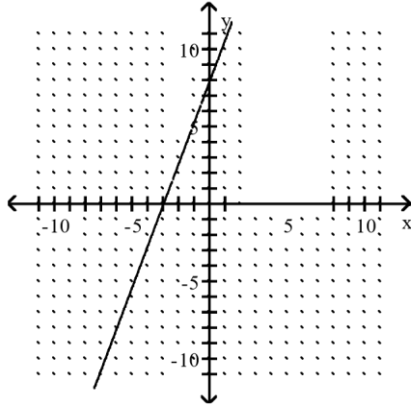

B) $(0, 8); (3, 0)$

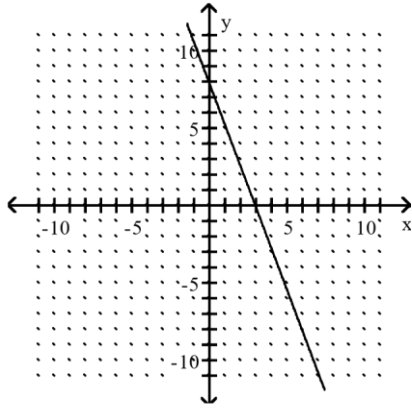

C) $(0, -3); (8, 0)$

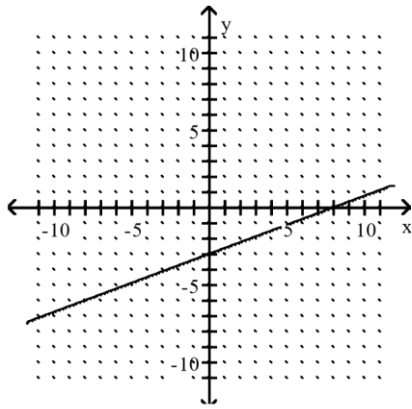

D) $(0, 3); (8, 0)$

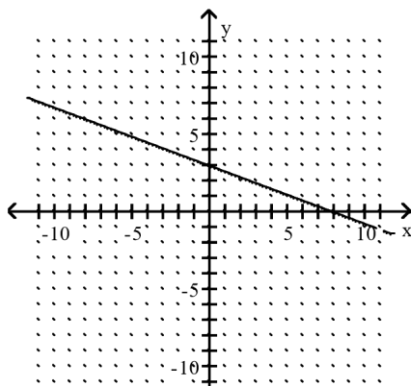

217) $1.2y - 2.6x = 9.36$

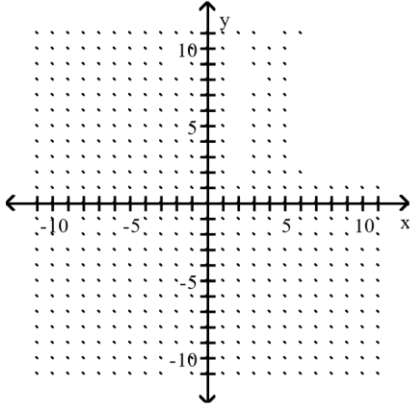

A) $(0, 3.6); (7.8, 0)$

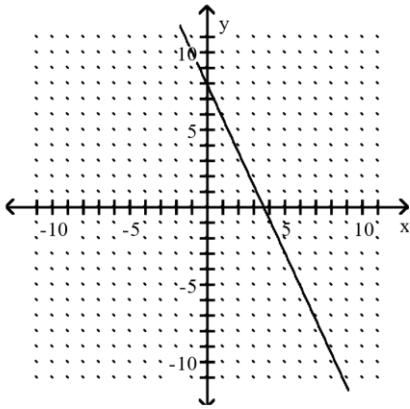

B) $(0, -3.6); (7.8, 0)$

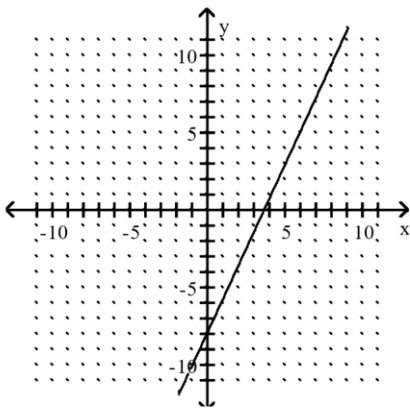

C) $(0, -7.8); (-3.6, 0)$

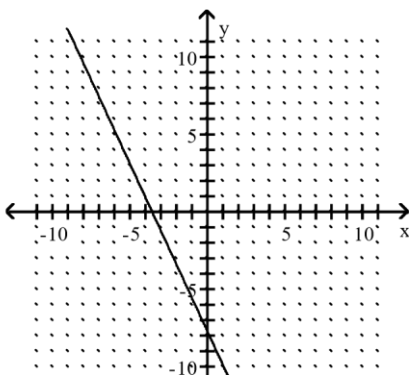

D) $(0, 7.8); (-3.6, 0)$

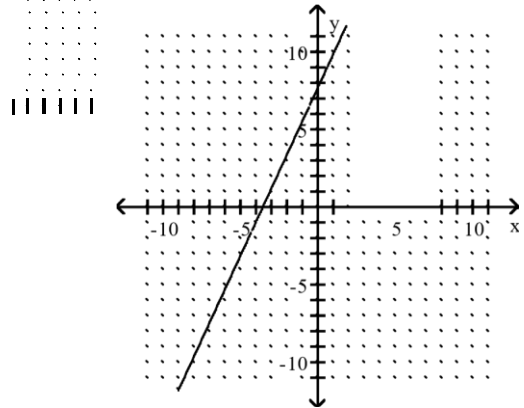

Answer: D

218) $2x - 4 f(x) = 4$

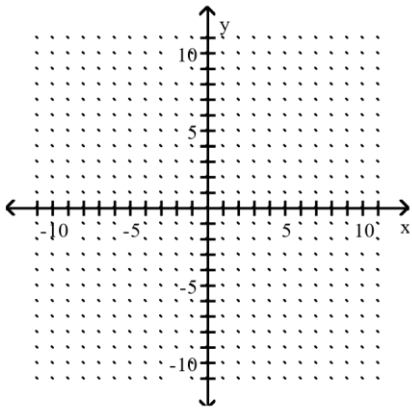

A) $(0, -1); (2, 0)$

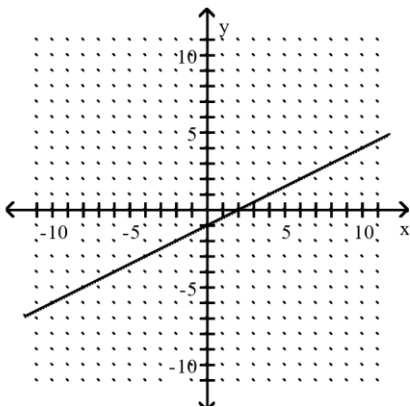

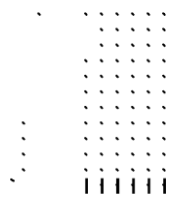

B) $(0, -1); (-2, 0)$

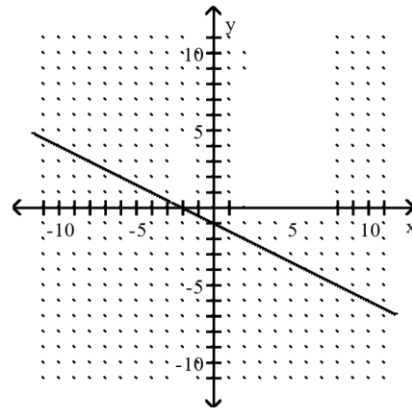

C) $(0, 1); (-2, 0)$

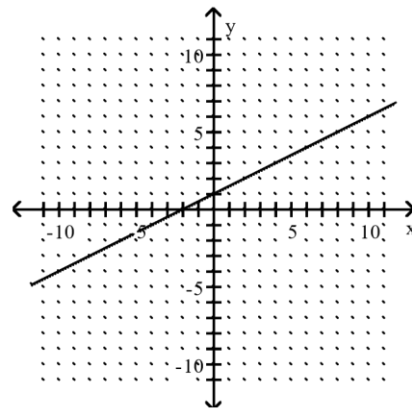

D) $(0, 1); (2, 0)$

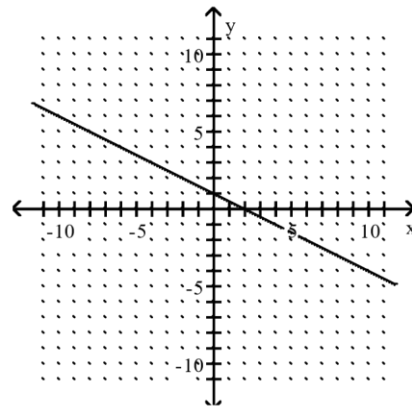

Answer: A

219) $-3x = -4y$

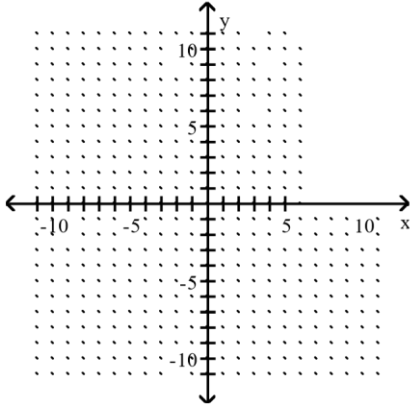

A) $(0, 0); (-3, -4)$

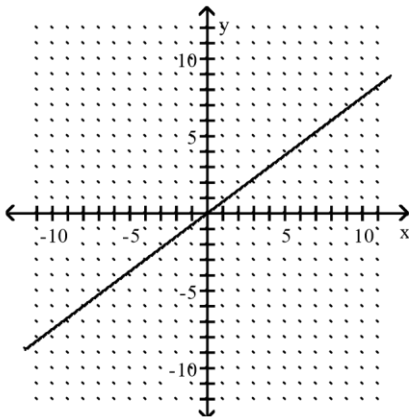

B) $(0, -3); (-4, 0)$

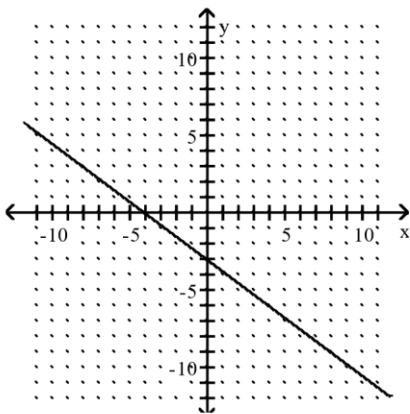

C) $(0, 0); (0, 0)$

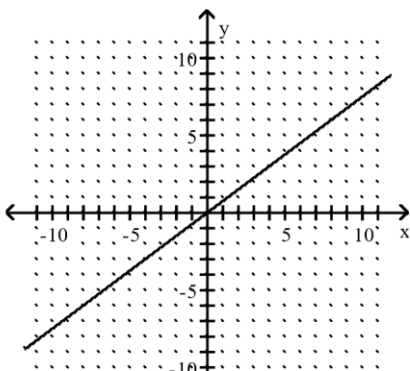

D) (0, -4); (-3, 0)

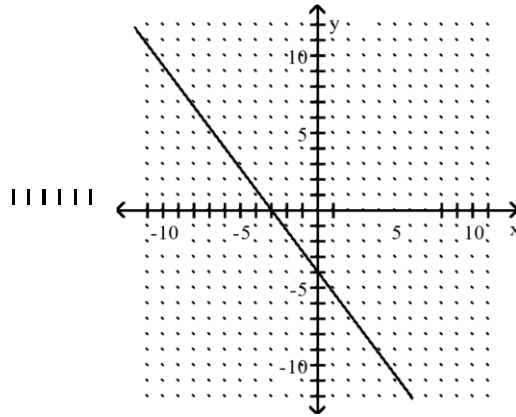

Answer: C

Solve the equation.

220) $s + 1 = 8$

A) 7 B) 9 C) -9

D) -7 Answer: A

221) $10x + 2 = 92$

A) 80 B) 84

C) 7 D) 9

Answer: D

222) $4x - 4 = 4$

A) 8 B) 4 C) 5 D) 2 Answer:

D

223) $78 = 8x - 2$

A) 10

B) 76

C) 72 D) 11

Answer: A

224) $-6x - 8 = -1 +$

$\frac{7x}{13}$

A) $-\frac{13}{7}$ B) $-\frac{1}{9}$ C) $-\frac{7}{13}$

D) $\frac{13}{7}$

Answer: C

225) $10x + 4 = 6 - 5x$

- A) $-\frac{15}{2}$
- B) $\frac{15}{2}$
- C) $\frac{2}{15}$
- D) $\frac{1}{2}$

Answer: C

226) $\frac{1}{2x} - \frac{1}{2} = -2$

- A) -3 B) -5
- C) 3
- D) 5

Answer: A

227) $\frac{1}{2x} - 5 = 1$

- A) -12
- B) -8
- C) 12
- D) 8

Answer: C

228) $\frac{2}{5x} - \frac{1}{3x} = 2$

- A) 60
- B) 30 C) -30 D) -60

Answer: B

229) $\frac{1}{4x} - \frac{3}{8} = x = 2$

- A) -16
- B) 14
- C) 16
- D) -14

Answer: A

Use a graph to estimate the solution.

230) The cost, c , in dollars of car rental is $7 + .25m$, where m is the number of miles driven.

Graph the equation and use the graph to estimate the cost of car rental if the number of miles driven is 25.

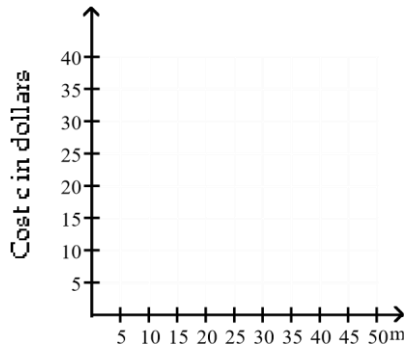

- A) About 26.75 dollars
- B) About 13 dollars
- C) About 18 dollars
- D) About 9 dollars

Answer: B

231) The value, v , in hundreds of dollars, of Juan's computer is approximated by $v = -.50t + 10$, where t is the number of years since he first bought the computer. Graph the equation and use the graph to estimate the value of the computer 6 years after it was purchased.

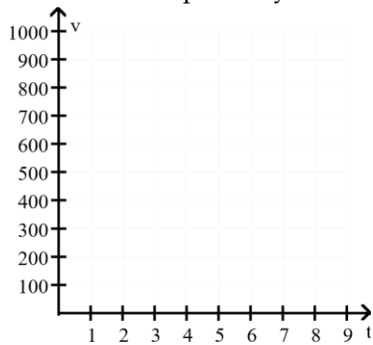

- A) \$1300
- B) \$880
- C) \$400
- D) \$700

Answer: D

232) During the month of January 1997, the depth, d , of snow in inches at the base of one ski resort could be approximated by $d = -2t + 64$, where t is the number of days since December 31st. Graph the equation and use the graph to estimate the depth of snow on January 24th.

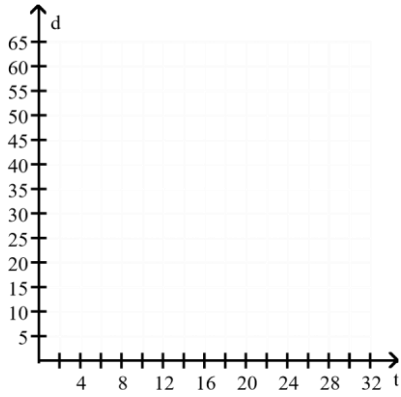

- A) 21 inches
- B) 24 inches
- C) 40 inches
- D) 16 inches

Answer: D

233) The cost, T , in hundreds of dollars, of tuition at one community college is given by $T = 3 + 1.25c$, where c is the number of credits for which a student registers. Graph the equation and use the graph to estimate the cost of tuition if a student registers for 11 credits.

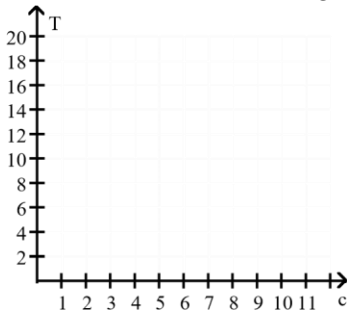

- A) About \$2700
- B) About \$2300
- C) About \$1500
- D) About \$1675

Answer: D

234) Alison sets aside \$40 each month to spend on books and CDs. If she spends c dollars on CDs in a given month she may spend b dollars on books where $c + b = 40$. Graph the equation and use the graph to estimate the amount Alison may spend on books in March if she spends \$30 on CDs.

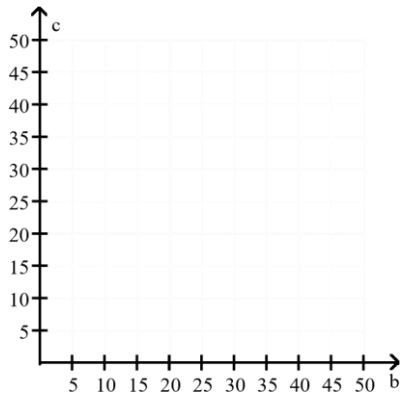

- A) \$10
- B) \$17
- C) \$21
- D) \$70

Answer: A

235) Suppose the sales of a particular brand of appliance satisfy the relationship $y = 60x + 3700$, where y represents the number of sales in year x , with $x = 0$ corresponding to 1982. Find the number of sales in 1989.

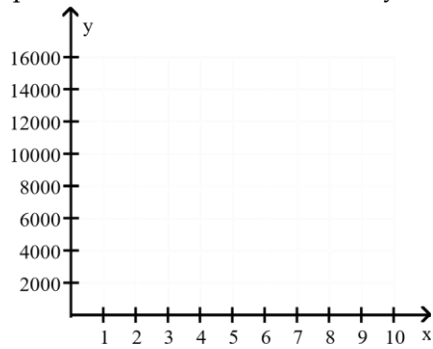

- A) 8240
- B) 4120
- C) 8180
- D) 4060

Answer: B

236) A new satellite television provider offers a monthly service for \$32. Additionally, the company charges \$10 for each pay-per-view movie. Estimate how many movies someone could watch in one month for a total cost of \$86.

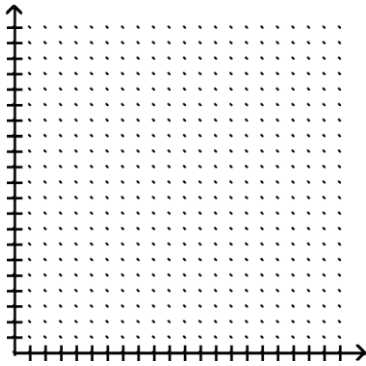

- A) 7
- B) 2
- C) 5
- D) 3

Answer: C

237) A long-distance carrier charges \$5.00 for one month's service. Additionally, the company charges \$0.13 per minute of calling. Estimate how many long-distance minutes someone could use in one month for a total cost of \$26.

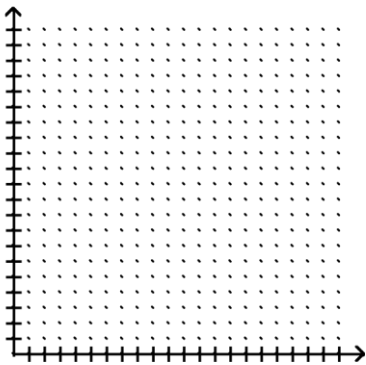

- A) 5
- B) 181
- C) 200
- D) 162

Answer: D

Determine whether the equation is linear.

238) $10x + 9y = -1$

- A) Linear
- B) Not Linear

Answer: A

239) $-99x - 77y = 0$

- A) Linear
- B) Not Linear

Answer: A

240) $-62f(x) = -6x^2$ A) Not Linear B) Linear Answer: A

241) $70g(x) - 46x = 56$

A) Not Linear

B) Linear

Answer: B

242) $96y + 28xy = -74$ A) Linear

B) Not Linear

Answer: B

243) $-43y + x^8 = 0$

A) Not Linear

B) Linear

Answer: A

— $g(x) - 89 = 79 + x$

244)

64

A) Not Linear

B) Linear

Answer: B

— $g(x) = -89 + x^2$

245)

99

A) Not Linear

B) Linear

Answer: A

Solve the problem.

246) Plot the data and determine if a linear function would give an approximate fit.

x	1	2	3	4
f(x)	10	14	18	22

A) No

B) Yes

Answer: B

247) Plot the data and determine if a linear function would give an approximate fit.

x	1	2	3	4
f(x)	7	13	18	32

- A) Yes
- B) No

Answer: B

248) Plot the data and determine if a linear function would give an approximate fit.

x	-2	-1	0	1
f(x)	-9	-4	1	6

- A) No
- B) Yes

Answer: B

249) Plot the data and determine if a linear function would give an approximate fit.

x	-2	-1	0	1
f(x)	-9	-1	6	15

- A) No
- B) Yes

Answer: A

SHORT ANSWER. Write the word or phrase that best completes each statement or answers the question.

250) Suppose that during a certain step in a chemical manufacturing process the amount of hydrogen sulfide dissolved in a solution, measured in parts per million (ppm), is related to the elapsed time measured from the beginning of the step. Use the following table as a representation of this relationship.

ELAPSED TIME (minutes)	2	4	6	8	10
AMOUNT DISSOLVED (ppm)	18.0	20.4	22.4	24.4	26.2

Represent the data in the table graphically with elapsed time on the horizontal axis and the amount of dissolved hydrogen sulfide on the vertical axis. Would a linear function give an approximate fit?

Answer: A linear function does give an approximate fit.

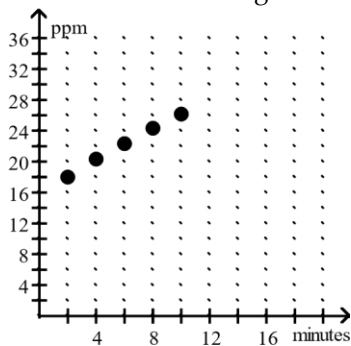

251) Suppose that the speed of a car, measured in miles per hour (mph), is monitored for some short period of time after the driver applies the brakes. The following table relates the speed of the car to the amount of time, measured in seconds (sec), elapsed from the moment that the brakes are applied.

ELAPSED TIME (sec)	3	6	9	12	15
SPEED of CAR (mph)	45	30	20	10	5

Represent the data in the table graphically with elapsed time on the horizontal axis and speed on the vertical axis. Would a linear function give an approximate fit?

Answer: A linear function does not give an approximate fit.

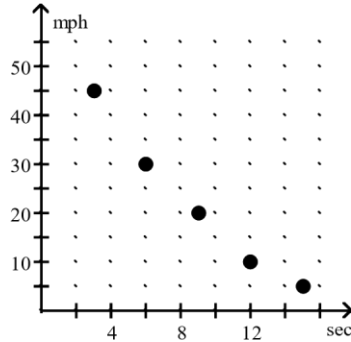

MULTIPLE CHOICE. Choose the one alternative that best completes the statement or answers the question.

For the point-slope equation given, state the slope and the point on the graph used in creating the equation.

252) $y - 8 = 9(x - 9)$

- A) $m = 9; (9, 8)$
- B) $m = 9; (-9, -8)$
- C) $m = 9; (-9, 8)$
- D) $m = -9; (9, -8)$

Answer: A

253) $y + 2 = -8(x - 1)$

- A) $m = -8; (1, -2)$
- B) $m = -8; (-1, 2)$
- C) $m = -8; (-1, -2)$
- D) $m = -8; (1, 2)$

Answer: A

254) $y + 6 = 4(x - 9)$

- A) $m = -4; (9, -6)$
- B) $m = -4; (-9, 6)$
- C) $m = 4; (-9, 6)$

D) $m = 4; (9, -6)$

Answer: D

255) $y - 5 = -5(x + 6)$

A) $m = -5; (6, -5)$ B) $m = 5; (6, -5)$

C) $m = 5; (-6, 5)$

D) $m = -5; (-6, 5)$

Answer: D

256) $y - 6 = -\frac{3}{4}(x + 2)$

A) $m = -\frac{3}{4}; (-3, -4)$

B) $m = \frac{3}{4}; (-2, 6)$

C) $m = -\frac{3}{4}; (-2, 6)$

D) $m = -\frac{3}{4}; (-3, 4)$

Answer: C

257) $y + 4 = 9x$

A) $m = 9; (0, 4)$ B) $m = -9; (-4, 0)$ C) $m = 9; (0, -4)$

D) $m = 9; (-4, 0)$

Answer: C

258) $y = \frac{1}{6}(x - 6)$

A) $m = -\frac{1}{6}; (0, 6)$

B) $m = \frac{1}{6}; (0, -6)$

C) $m = \frac{1}{6}; (6, 0)$

D) $m = \frac{1}{6}; (-6, 0)$

Answer: C

259) $y = -\frac{7}{10}x$

A) $m = \frac{7}{10}; (0, 0)$

B) $m = -\frac{7}{10}; (0, 0)$

C) $m = -\frac{7}{10}; (7, 10)$

$$D) m = \frac{7}{10}; (7, 10)$$

Answer: B

Find an equation for the described linear function.

260) Through (0, 4) and parallel to $y = -7x - 7$ A) $y = -7x + 4$ B) $y = 7x + 4$

C) $y = -7x - 4$

D) $y = \frac{1}{7}x + 4$

Answer: A

261) Through (0, -9) and parallel to $-4x + y = 7$

A) $y = \frac{1}{4}x - 9$

B) $y = -4x + 9$

C) $y = -4x - 9$ D) $y = 4x - 9$

Answer: D

262) Through (0, 1) and parallel to $4y = 16$

A) $y = 4x + 1$

B) $y = -1$

C) $y = 5$

D) $y = 1$

Answer: D

263) Through $\left(0, \frac{2}{7}\right)$ and parallel to $3x - 9y = 8$

A) $y = -3x + \frac{2}{7}$

B) $y = 3x + \frac{2}{7}$

C) $y = \frac{1}{3}x + \frac{2}{7}$

D) $y = -\frac{1}{3}x + \frac{2}{7}$

Answer: C

264) Through $\left(0, \frac{3}{8}\right)$ and parallel to $2x + 6y = 7$

A) $y = 2x + \frac{3}{8}$ B) $y = \frac{1}{3}x + \frac{3}{8}$

C) $y = -\frac{1}{3}x + \frac{3}{8}$

D) $y = 3x + \frac{3}{8}$

Answer: C

265) Through $(0, -5)$ and perpendicular to $y = 6x + 4$

A) $y = \frac{1}{6}x - 5$ B) $y = -\frac{1}{6}x - 5$

C) $y = -\frac{1}{6}x + 5$

D) $y = 6x -$

5 Answer: B

266) Through $(0, -4)$ and perpendicular to $y = x + 3$

A) $y = x - 4$ B) $y = -x - 4$ C) $y = x + 4$

D) $y = -x + 4$

Answer: B

267) Through $\left(0, \frac{2}{7}\right)$ and perpendicular to $6x + 4y = 4$

A) $y = \frac{2}{3}x + \frac{2}{7}$ B) $y = -\frac{3}{2}x + \frac{2}{7}$

C) $y = \frac{3}{2}x + \frac{2}{7}$

D) $y = 6x - \frac{2}{7}$

Answer: A

268) Through $\left(0, \frac{-6}{8}\right)$ and perpendicular to $5x - 8y = 1$

A) $y = \frac{5}{8}x + \frac{6}{5}$

B) $y = \frac{5}{8}x - \frac{6}{5}$

C) $y = 8x + \frac{6}{5}$

D) $y = -\frac{8}{5}x - \frac{6}{5}$

Answer: D

269) Through $\left(0, \frac{7}{8}\right)$ and perpendicular to $8x + y = 2$

A) $y = -8x + \frac{7}{8}$

B) $y = \frac{1}{8}x + \frac{7}{8}$

C) $y = 8x + \frac{7}{8}$

D) $y = 8x - \frac{7}{8}$ Answer: B

Find an equation in point-slope form of the line having the specified slope and containing the point indicated.

270) $m = -5, (5, 7)$

- A) $y - 5 = 5(x - 7)$
- B) $y + 5 = 5(x + 7)$
- C) $y - 7 = -5(x - 5)$
- D) $y + 7 = -5(x + 5)$

Answer: C

271) $m = -9, (3, -7)$

- A) $x - 7 = 9(y + 3)$
- B) $y + 7 = -9(x - 3)$
- C) $x + 7 = 9(y - 3)$
- D) $y - 7 = -9(x + 3)$

Answer: B

272) $m = 4, (8, -8)$

- A) $y + 8 = 4(x - 8)$
- B) $y - 8 = 4(x + 8)$
- C) $y - 8 = 4(x - 8)$
- D) $y + 8 = 4(x + 8)$

Answer: A

273) $m = -6, (-2, 7)$

- A) $y + 7 = -6(x - 2)$
- B) $y + 7 = -6(x + 2)$
- C) $y - 7 = -6(x - 2)$
- D) $y - 7 = -6(x + 2)$

Answer: D

274) $m = \frac{3}{4}, (-6, -2)$

- A) $y - 2 = \frac{3}{4}(x - 6)$
- B) $y - 2 = \frac{3}{4}(x + 6)$
- C) $y + 2 = \frac{3}{4}(x - 6)$
- D) $y + 2 = \frac{3}{4}(x + 6)$

Answer: D

275) $m = 2, (0, -3)$

- A) $y = 2(x + 3)$

- B) $y + 3 = 2x$
- C) $y = 2(x - 3)$
- D) $y - 3 = 2x$

Answer: B

276) $m = -2, (6, 0)$

- A) $y + 6 = -2x$ B) $y = -2(x + 6)$
- C) $y - 6 = -2x$
- D) $y = -2(x - 6)$

Answer: D

277) $m = \frac{5}{9}, (-8, 6)$

- A) $y + 6 = \frac{5}{9}(x - 8)$
- B) $y + 8 = \frac{5}{9}(x - 6)$
- C) $y - 6 = \frac{5}{9}(x + 8)$
- D) $y - 8 = \frac{5}{9}(x + 6)$

Answer: C

Find an equation of the line having the specified slope and containing the indicated point. Write your answer in slope-intercept form.

278) $m = -3; (5, -3)$

- A) $f(x) = -3x + 12$
- B) $f(x) = -3x + 10$
- C) $f(x) = -3x + 13$ D) $f(x) = 3x + 11$

Answer: A

279) $m = -9; (-8, 6)$

- A) $f(x) = 9x - 68$
- B) $f(x) = -9x - 67$
- C) $f(x) = -9x - 74$
- D) $f(x) = -9x - 66$

Answer: D

280) $m = 9; (0, 4)$

- A) $f(x) = 9x + 11$
- B) $f(x) = 9x + 9$
- C) $f(x) = -9x + 2$ D) $f(x) = 9x + 4$

Answer: D

281) $m = 6; (0, -3)$

A) $f(x) = 6x - 3$

B) $f(x) = -6x - 1$

C) $f(x) = 6x + 3$

D) $f(x) = 6x + 5$

Answer: A

282) $m = 3; (-8, 0)$

A) $f(x) = 3x + 24$

B) $f(x) = 3x - 27$

C) $f(x) = 3x - 25$

D) $f(x) = -3x + 20$

Answer: A

283) $m = 1.7; (9, -2)$

A) $f(x) = 1.7x - 17.3$

B) $f(x) = 1.7x - 13.3$

C) $f(x) = 1.7x + 13.3$

D) $f(x) = 1.7x + 17.3$

Answer: A

284) $m = -\frac{3}{4}; (3, -1)$

A) $f(x) = -\frac{3}{4}x + \frac{13}{4}$

B) $f(x) = -\frac{3}{4}x + \frac{5}{4}$

C) $f(x) = -\frac{3}{4}x + 2$

D) $f(x) = \frac{3}{4}x - \frac{5}{4}$

Answer: B

285) $m = -3; (0, 9.4)$

A) $f(x) = 9.4x - 3$

B) $f(x) = -3x + 9.4$

C) $f(x) = 9.4x + 3$

D) $f(x) = -3x - 9.4$

Answer: B

286) $m = \frac{4}{5}; (-1, 1)$

A) $f(x) = \frac{4}{5}x + \frac{9}{5}$

B) $f(x) = \frac{4}{5}x + 1$

$$\text{C) } f(x) - 1 = \frac{4}{5}(x + 1)$$

$$\text{D) } f(x) = -\frac{4}{5}x + \frac{9}{5}$$

Answer: A

$$287) m = -\frac{1}{3}; (-10, 0)$$

$$\text{A) } f(x) = \frac{1}{3}x + \frac{10}{3}$$

$$\text{B) } f(x) = \frac{1}{3}x - \frac{10}{3} \quad \text{C)$$

$$f(x) = -\frac{1}{3}x - \frac{10}{3}$$

$$\text{D) } f(x) = -\frac{1}{3}x - 10$$

Answer: C

Find an equation of the line containing the given pair of points. Write your final answer as a linear function in slope-intercept form.

$$288) (-5, -4) \text{ and } (-4, -2)$$

$$\text{A) } f(x) = 6x + 2$$

$$\text{B) } f(x) = 2x + 6$$

$$\text{C) } f(x) = -2x + 6 \quad \text{D) } f(x) = 6x - 2$$

Answer: B

$$289) (-5, 9) \text{ and } (0, 5)$$

$$\text{A) } f(x) = \frac{14}{5}x + 5 \quad \text{B) } f(x) = -\frac{4}{5}x + 5$$

$$\text{C) } f(x) = -\frac{14}{5}x + 5$$

$$\text{D) } f(x) = \frac{4}{5}x + 5$$

Answer: B

$$290) (6, 0) \text{ and } (2, 5)$$

$$\text{A) } f(x) = \frac{3}{2}x + \frac{15}{2}$$

$$\text{B) } f(x) = -\frac{3}{2}x + \frac{15}{2}$$

$$\text{C) } f(x) = -\frac{5}{4}x + \frac{15}{2}$$

$$\text{D) } f(x) = \frac{5}{4}x + \frac{15}{2}$$

Answer: C

- 291) (-9, -4) and (4, 6)
- A) $f(x) = -\frac{10}{13}x + \frac{38}{13}$
- B) $f(x) = \frac{10}{13}x + \frac{38}{13}$
- C) $f(x) = -\frac{5}{13}x + \frac{38}{13}$
- D) $f(x) = \frac{5}{13}x + \frac{38}{13}$

Answer: B

- 292) (-8, 2) and (-5, 4)
- A) $f(x) = -\frac{10}{3}x + \frac{22}{3}$
- B) $f(x) = \frac{2}{3}x + \frac{22}{3}$
- C) $f(x) = \frac{10}{3}x + \frac{22}{3}$
- D) $f(x) = -\frac{2}{3}x + \frac{22}{3}$

Answer: B

- 293) (1, 5) and (10, 5)
- A) $f(x) = 5$
- B) $f(x) = -10x$
- C) $f(x) = -\frac{1}{10}x$
- D) $f(x) = 1$

Answer: A

- 294) (2.1, -6) and (5.1, -0.8)
- A) $f(x) = -2.27x - 5.64$ B) $f(x) = 1.73x - 5.64$
- C) $f(x) = 1.73x - 9.64$
- D) $f(x) = -2.27x - 9.64$

Answer: C

Solve the problem.

- 295) A gas station sells 4820 gallons of regular unleaded gasoline on a day when they charge \$1.35 per gallon, whereas they sell 3919 gallons on a day that they charge \$1.40 per gallon. Find a linear function that expresses gallons sold as a function of price.
- A) $G(p) = -18,020p + 29,147$
- B) $G(p) = -18,020p + 29,163$
- C) $G(p) = -18,020p + 29,130.8$
- D) $G(p) = -18,020p + 29,125.2$

Answer: A

296) A gas station sells 4820 gallons of regular unleaded gasoline in a day when they charge \$1.35 per gallon, whereas they sell 3851 gallons on a day that they charge \$1.40 per gallon. Find a linear function that expresses gallons sold as a function of price. Use this function to predict the number of gallons sold at a price of \$1.22 per gallon.

- A) 7348.4 gallons
- B) 7336.1 gallons
- C) 7339.4 gallons
- D) 7343.5 gallons

Answer: C

297) Persons taking a 30-hour review course to prepare for a standardized exam average a score of 620 on that exam. Persons taking a 70-hour review course average a score of 757. Find a linear function $S(t)$, which fits this data, and which expresses score as a function of time.

- A) $S(t) = 3.0825t + 521.25$
- B) $S(t) = 3.425t + 517.25$
- C) $S(t) = 3.0825t - 521.25$
- D) $S(t) = -3.425t + 517.25$

Answer: B

298) Persons taking a 30-hour review course to prepare for a standardized exam average a score of 620 on that exam. Persons taking a 70-hour review course average a score of 750. Find a linear function, $S(t)$, which fits this data, and which expresses score as a function of time. Use this function to predict an average score for persons taking a 45-hour review course. Round your answer to the tenths place.

- A) 668.8
- B) 682.8
- C) 661.5
- D) 673.0

Answer: A

299) In 1995 the United States recovered 20% of its municipal solid wastes through recycling, up from 17% in 1990. Let P represent the percentage recycled and t the number of years since 1990. Find a linear function $P(t)$ that fits this data.

- A) $P(t) = 0.6t + 24$ B) $P(t) = -0.6t + 7$ C) $P(t) = 0.6t + 17$
- D) $P(t) = 0.3t - 17$

Answer: C

300) In 1995 the United States recovered 20% of its municipal wastes through recycling, up from 17% in 1990. Let P represent the percentage recycled and t the number of years since 1990. Find a linear function $P(t)$ that fits this data. Use this function to predict the percentage recycled in 2003.

- A) 24.8%
- B) 22.9%
- C) 21.2%
- D) 26.5%

Answer: A

301) The total sales made by a salesperson was \$25,000 after 3 months and \$68,000 after 23 months. Predict the total sales after 32 months.

- A) \$87,320
- B) \$87,350
- C) \$87,450
- D) \$87,392

Answer: B

302) In 1985, John invested \$21,000 in the stock market. By 1995 his investment had grown to \$22,000. If the market continues to grow at the same rate, how much will be in his account in 1997? Give your answer to the nearest dollar.

- A) \$21,201
- B) \$23,000
- C) \$22,200
- D) \$22,000

Answer: C

303) In 1880 the population of a midwest city was 19,000. By 1920 it had grown to 20,000. If it continues to grow at the same rate, what will the population be in 1939? Give your answer to the nearest whole number. A) 21,000

- B) 19,476
- C) 20,000
- D) 20,475

Answer: D

Solve.

304) Let $f(x) = 8x + 6$ and $g(x) = 7x^2 + 5$. Find $f(7) + g(7)$.

- A) 404
- B) 410
- C) 405
- D) 399

Answer: B

305) Let $f(x) = -8x + 4$ and $g(x) = 3x^2 + 5$. Find $f(7) + g(7)$.

- A) 95
- B) 100
- C) 96
- D) 91

Answer: B

306) Let $f(x) = 9x + 5$ and $g(x) = 2x^2 + 6$. Find $f(9) - g(9)$.

- A) -76
- B) -81
- C) -87

D) -82

Answer: D

307) Let $f(x) = -2x + 5$ and $g(x) = 4x^2 + 6$. Find $f(3) - g(3)$.

A) -48

B) -37

C) -43

D) -42

Answer: C

308) Let $f(x) = 9x + 3$ and $g(x) = 4x^2 + 8$. Find $g(9) - f(9)$.

A) 251

B) 248

C) 243

D) 240

Answer: B

309) Let $f(x) = -6x + 6$ and $g(x) = 6x^2 + 8$. Find $g(8) - f(8)$.

A) 434

B) 426

C) 432

D) 440

Answer: A

310) Let $f(x) = 9x + 2$ and $g(x) = 5x^2 + 5$. Find $f(2) \cdot g(2)$.

A) 400

B) 500

C) 360

D) 450

Answer: B

311) Let $f(x) = -3x + 9$ and $g(x) = 3x^2 + 4$. Find $f(5) \cdot g(5)$.

A) -450

B) -474

C) -1125

D) -1185 Answer: B

312) Let $f(x) = 4x + 3$ and $g(x) = 5x^2 + 2$. Find $g(2) / f(2)$.

A) 2

B) $\frac{11}{4}$

- C) $\frac{20}{11}$
 D) $\frac{5}{2}$

Answer: A

313) Let $f(x) = -8x + 7$ and $g(x) = 5x^2 + 5$. Find $f(7) / g(7)$.

- A) $-\frac{8}{35}$
 B) $-\frac{1}{5}$
 C) $-\frac{49}{250}$
 D) $-\frac{28}{125}$

Answer: C For the pair of functions, find the indicated sum, difference, product, or quotient. 314) $f(x) = 7x - 4$, $g(x) = 4x - 7$ Find $(f - g)(x)$.

- A) $3x - 11$
 B) $-3x - 3$
 C) $3x + 3$
 D) $11x - 11$

Answer: C

315) Find $(f - g)(4)$ when $f(x) = -5x^2 - 5$ and $g(x) = x - 3$.

- A) -92
 B) -86
 C) 81
 D) -78

Answer: B

316) $f(x) = 9 - 7x$, $g(x) = -4x + 7$ Find

- $(f + g)(x)$.
 A) $-11x + 16$
 B) $-3x + 16$
 C) $5x$
 D) $-4x + 9$

Answer: A

317) $f(x) = 2 - 2x$, $g(x) = -5x^2 + 2$ Find

- $(f + g)(x)$.
 A) $-5x^2 + 2$
 B) $-7x + 4$

C) $-5x^2 - 2x + 4$

D) $-7x^2 - 2x + 4$

Answer: C

318) Find $(f + g)(1)$ when $f(x) = x + 3$ and $g(x) = x - 6$.

A) 11

B) -1

C) 5

D) -7

Answer: B

319) $f(x) = 2x^2 - 5x$, $g(x) = x^2 - 2x - 15$ Find $(f/g)(x)$.

$\frac{2x}{x}$

A)

15

$\frac{2x}{x+1}$

B) $x + 1$

$\frac{2x-5}{-2}$ C)

-2

$\frac{2x^2 - 5x}{x^2 - 2x - 15}$

D) _____

$x^2 - 2x - 15$

Answer: D

320) Find $f/g(-4)$ when $f(x) = 2x - 2$ and $g(x) = 2x^2 + 14x + 4$.

A) $-\frac{1}{10}$

B) $\frac{1}{3}$

C) $-\frac{1}{10}$

D) $\frac{1}{2}$

Answer: D

321) $f(x) = 2x + 3$, $g(x) = 5x + 7$ Find $(f \cdot g)(x)$.

A) $10x^2 + 22x + 21$

B) $10x^2 + 29x + 21$

C) $10x^2 + 21$

D) $7x^2 + 29x + 10$

Answer: B

- 322) $f(x) = x^2 + 1$, $g(x) = 3x - 5$ Find $(f \cdot g)(x)$.
- A) $3x^3 - 5x^2 + 3x - 5$
 B) $3x^3 - 5$
 C) $3x^3 + 3x^2 - 5x - 5$ D) $3x^2 + 3x - 5$ Answer: A

- 323) Find $(f \cdot g)(4)$ when $f(x) = x - 1$ and $g(x) = -5x^2 + 18x + 3$.
- A) -25
 B) -15
 C) -385 D) 273

Answer: B

The graph below indicates the number of new cases of Chalk Dust Disease (CDD) diagnosed each month in the Mathland. Let $T(t)$ represent the total number of new cases per month, $F(t)$ the number of new cases per year among algebraists, $G(t)$ the number of new cases per year among geometers, and t the number of years since January 1, 1990.

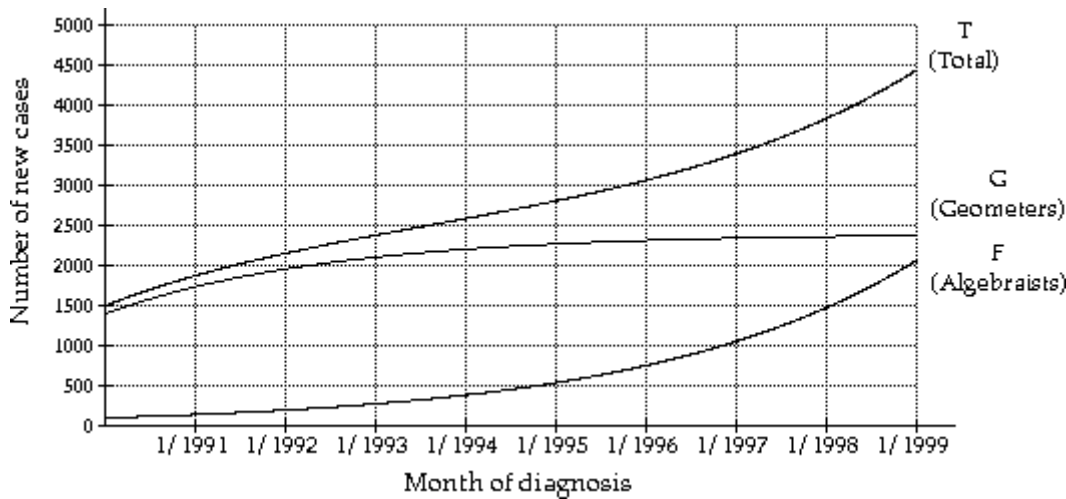

- 324) Estimate $G(7)$ and interpret its meaning.
- A) 2300; In January, 1997, there were about 2300 new cases of CDD diagnosed among geometers. B) 3400; In January, 1997, there were about 3400 new cases of CDD diagnosed among geometers.
 C) 3400; In January, 1997, there were about 3400 new cases of CDD diagnosed.
 D) 1100; In January, 1997, there were about 1100 new cases of CDD diagnosed among algebraists.

Answer: A

- 325) Estimate $F(4)$ and interpret its meaning.
- A) 2200; In January, 1994, there were about 2200 new cases of CDD diagnosed among geometers.
 B) 380; In January, 1994, there were about 380 new cases of CDD diagnosed among geometers.
 C) 380; In January, 1994, there were about 380 new cases of CDD diagnosed among algebraists.
 D) 2600; In January, 1994, there were about 2600 new cases of CDD diagnosed. Answer: C

- 326) Estimate $T(1)$ and interpret its meaning.

A) 1700; In January, 1991, there were about 1700 new cases of CDD diagnosed among geometers. B) 1900; In January, 1991, there were about 1900 new cases of CDD diagnosed among geometers.

C) 140; In January, 1991, there were about 140 new cases of CDD diagnosed among algebraists.

D) 1900; In January, 1991, there were about 1900 new cases of CDD diagnosed.

Answer: D

327) Estimate $(G + F)(9)$ and interpret its meaning.

A) 2400; In January, 1999, there were about 2400 new cases of CDD diagnosed among geometers.

B) 2100; In January, 1999, there were about 2100 new cases of CDD diagnosed among algebraists.

C) 4400; In January, 1999, there were about 4400 new cases of CDD diagnosed.

D) 4400; In January, 1999, there were about 4400 new cases of CDD diagnosed among geometers.

Answer: C

328) Estimate $(T - F)(8)$ and interpret its meaning.

A) 3800; In January, 1998, there were about 3800 new cases of CDD diagnosed.

B) 2400; In January, 1998, there were about 2400 new cases of CDD diagnosed among geometers.

C) 1500; In January, 1998, there were about 1500 new cases of CDD diagnosed among algebraists.

D) 3800; In January, 1998, there were about 3800 new cases of CDD diagnosed among geometers.

Answer: B

329) Estimate $(T - G)(1)$ and interpret its meaning.

A) 140; In January, 1991, there were about 140 new cases of CDD diagnosed among geometers.

B) 1700; In January, 1991, there were about 1700 new cases of CDD diagnosed among geometers.

C) 1900; In January, 1991, there were about 1900 new cases of CDD diagnosed.

D) 140; In January, 1991, there were about 140 new cases of CDD diagnosed among algebraists.

Answer: D

For the functions $f(x)$ and $g(x)$, determine the domain of $(f + g)(x)$ (the sum of f and g).

330) $f(x) = 11x^2$, $g(x) = 7x - 2$

A) $\{x \mid x \text{ is a real number and } x \neq 2\}$

B) $\{x \mid x \text{ is a real number and } x \neq 7\}$

C) $\{x \mid x \text{ is a real number}\}$

D) $\{x \mid x \text{ is a real number and } x \neq -7\}$

Answer: C

331) $f(x) = \frac{2}{x - 11}$, $g(x) = -3x - 5$

A) $\{x \mid x \text{ is a real number and } x \neq -11\}$

B) $\{x \mid x \text{ is a real number}\}$

C) $\{x \mid x \text{ is a real number and } x \neq 11\}$

D) $\{x \mid x \text{ is a real number and } x \neq 5\}$

Answer: C

332) $f(x) = \frac{11}{x}, g(x) = 6x^2 - 5x$

A) $\{x \mid x \text{ is a real number and } x \neq 5\}$

B) $\{x \mid x \text{ is a real number and } x \neq 0\}$

C) $\{x \mid x \text{ is a real number}\}$

D) $\{x \mid x \text{ is a real number and } x \neq -6\}$

Answer: B

333) $f(x) = \frac{11}{x}, g(x) = -5x^3$

A) $\{x \mid x \text{ is a real number and } x \neq -11\}$

B) $\{x \mid x \text{ is a real number and } x \neq 11\}$

C) $\{x \mid x \text{ is a real number}\}$

D) $\{x \mid x \text{ is a real number and } x \neq 0\}$

Answer: D

f(x)

A) _____ ≠

B)

C)

D)

Answer:

334) $f(x) = \frac{x^5}{x-3}$, $g(x) = \frac{x^3-6}{x-3}$

{x | x is a real number and x ≠ 3 and x ≠ 6}

{x | x is a real number and x ≠ -3 and x ≠ -6}

{x | x is a real number and x ≠ 3}

{x | x is a real number}

A

335) $f(x) = 3x + \frac{4}{x-3}$, $g(x) = 1 - x^2$

A) {x | x is a real number} B) {x | x is a real number and x ≠ 1}

C) {x | x is a real number and x ≠ 3}

D) {x | x is a real number and x ≠ -3}

Answer: C

336) $f(x) = 3x + \frac{x^5}{x-3}$, $g(x) = \frac{x^3}{5+x}$

A) {x | x is a real number and x ≠ 3 and x ≠ -5}

B) {x | x is a real number and x ≠ -3 and x ≠ 5} C) {x | x is a real number and x ≠ 3} D) {x | x is a real number}

Answer: A

For the functions f(x) and g(x), determine the domain of (f - g)(x) (the difference of f and g).

337) $f(x) = 8x^2$, $g(x) = 9x - 2$

A) {x | x is a real number and x ≠ -9}

B) {x | x is a real number and x ≠ 9}

C) {x | x is a real number}

C) {x |

D) {x |

Answer:

f(x)

- A)
- B)
- C)
- D)

Answer:

D) {x | x is a real number and x ≠ 2}

Answer: C

338) $f(x) = \frac{2}{x-6}, g(x) = -3x-5$

- A) {x | x is a real number and x ≠ 5}
- B) {x | x is a real number and x ≠ -6}
- C) {x | x is a real number}
- D) {x | x is a real number and x ≠ 6}

Answer: D

339) $f(x) = \frac{3}{x-8}, g(x) = 8x^2 - 5x$

- A) {x | x is a real number and x ≠ 0}
- B) {x | x is a real number and x ≠ -8} x is a real number and x ≠ 5} x is a real number}

A

340) $f(x) = \frac{6}{x-3}, g(x) = -3x^3$

- {x | x is a real number}
- {x | x is a real number and x ≠ 6}
- {x | x is a real number and x ≠ -6}
- {x | x is a real number and x ≠ 0}

D

341) $f(x) = \frac{5}{x-3}, g(x) = \frac{3}{2-x}$

- A) {x | x is a real number and x ≠ 3}
- B) {x | x is a real number}
- C) {x | x is a real number and x ≠ 3 and x ≠ 2}
- C) {x |
- D) {x |

Answer:

f(x)

- A) \neq
- B)
- C)
- D)

Answer:

D) $\{x \mid x \text{ is a real number and } x \neq -3 \text{ and } x \neq -2\}$

Answer: C

342) $f(x) = 3x + \frac{4}{x-6}, g(x) = 1 - x^2$

- A) $\{x \mid x \text{ is a real number and } x \neq 1\}$
- B) $\{x \mid x \text{ is a real number}\}$
- C) $\{x \mid x \text{ is a real number and } x \neq 6\}$
- D) $\{x \mid x \text{ is a real number and } x \neq -6\}$

Answer: C

343) $f(x) = \frac{5}{x-3}, g(x) = \frac{3}{5+x}$

- A) $\{x \mid x \text{ is a real number}\}$
- B) $\{x \mid x \text{ is a real number and } x \neq 3\}$
- C) $\{x \mid x \text{ is a real number and } x \neq 3 \text{ and } x \neq -5\}$
- D) $\{x \mid x \text{ is a real number and } x \neq -3 \text{ and } x \neq 5\}$

Answer: C

344) $f(x) = \frac{4}{x-11}, g(x) = \frac{3}{x+8}$

- A) $\{x \mid x \text{ is a real number}\}$
- B) $\{x \mid x \text{ is a real number and } x \neq -11 \text{ and } x \neq 8\}$
- C) $\{x \mid x \text{ is a real number and } x \neq 11 \text{ and } x \neq -8\}$
- D) $\{x \mid x \text{ is a real number and } x \neq 0\}$

Answer: C

For the functions f(x) and g(x), determine the domain of (f · g)(x) (the product of f and g).

345) $f(x) = 7x^2, g(x) = 8x - 2$

- C) $\{x \mid$
- D) $\{x \mid$

Answer:

f(x)

- A)
- B)
- C)
- D)

Answer:

A) {x | x is a real number and x ≠ -8}

B) {x | x is a real number} x is a real number and x ≠ 8} x is a real number and x ≠ 2}

B

346) $= \frac{2}{x-7}, g(x) = -7x - 5$

{x | x is a real number and x ≠ -7}

{x | x is a real number}

{x | x is a real number and x ≠ 7} {x | x is a real number and x ≠ 5}

C

347) $f(x) = \underline{\quad}^{12}, g(x) = 9x^2 - 5x$

A) {x | x is a real number and x ≠ 0} B) {x | x is a real number}

C) {x | x is a real number and x ≠ -9}

D) {x | x is a real number and x ≠ 5}

Answer: A

348) $f(x) = \underline{\quad}^4, g(x) = -6x^3$

A) {x | x is a real number and x ≠ 4}

B) {x | x is a real number and x ≠ 0}

C) {x | x is a real number and x ≠ -4} D) {x |

x is a real number}

Answer: B

C) {x |

D) {x |

Answer:

f(x)

A) _____ ≠

B)

C)

D)

Answer:

349) $f(x) = \frac{5}{x-3}$

, $g(x) = \frac{3}{7-x}$

A) {x | x is a real number} B) {x | x is a real number and x ≠ 3}

C) {x | x is a real number and x ≠ 3 and x ≠ 7}

D) {x | x is a real number and x ≠ -3 and x ≠ -7}

Answer: C

350) $f(x) = 3x + \frac{4}{x-4}$, $g(x) = 1 - \frac{1}{x^2}$

A) {x | x is a real number and x ≠ 4}

B) {x | x is a real number and x ≠ 1} C) {x | x is a real number}

D) {x | x is a real number and x ≠ -4}

Answer: A

351) $f(x) = \frac{5}{x-3}$

, $g(x) = \frac{3}{7+x}$

A) {x | x is a real number and x ≠ -3 and x ≠ 7}

B) {x | x is a real number} x is a real number and x ≠ 3} x is a real number and x ≠ 3 and x ≠ -7}

D

C) {x |

D) {x |

Answer:

f(x)

- A)
- B)
- C)
- D)

Answer:

352) $\frac{f(x)}{g(x)} = \frac{x^4}{x^5 - 8x + 5}$

- {x | x is a real number}
- {x | x is a real number and $x \neq 0$ }
- {x | x is a real number and $x \neq 8$ and $x \neq -5$ }
- {x | x is a real number and $x \neq -8$ and $x \neq 5$ }

C

For the functions f(x) and g(x), determine the domain of (f/g)(x) (the quotient of f and g).

353) $f(x) = 10x^2, g(x) = 7x - 2$

- A) $\left\{ \begin{array}{l} x \mid x \text{ is a real number} \\ \text{and } x \neq \frac{-2}{7} \end{array} \right\}$
- B) $\{x \mid x \text{ is a real number}\}$
- C) $\left\{ \begin{array}{l} x \mid x \text{ is a real number} \\ \text{and } x \neq 0 \end{array} \right\}$
- D) $\{x \mid x \text{ is a real number and } x \neq \frac{-2}{7}\}$

Answer: D

354) $f(x) = 2x - 6, g(x) = 7x - 2$

- A) $\left\{ \begin{array}{l} x \mid x \text{ is a real number and } x \neq \frac{2}{7} \text{ and } x \neq 3 \end{array} \right\}$
- B) $\{x \mid x \text{ is a real number}\}$
- C) $\{x \mid x \text{ is a real number and } x \neq 3\}$
- D) $\left\{ \begin{array}{l} x \mid x \text{ is a real number and } x \neq \frac{2}{7} \end{array} \right\}$

Answer: D

355) $f(x) = \sqrt{x - 6}, g(x) = 13x - 5$

Answer:

$\left\{ \begin{array}{l} x \mid x \text{ is a real number} \\ \text{and } x \geq 6 \end{array} \right\}$

f(x)

- A) $x \mid x$ is a real number and $x \neq -6$ and $x \neq \frac{13}{5}$
- B) $x \mid x$ is a real number and $x \neq 6$ and $x \neq \frac{5}{13}$
- C) $x \mid x$ is a real number and $x \neq \frac{5}{13}$
- D) $x \mid x$ is a real number and $x \neq 6$

Answer: B

356) $f(x) = 13x - 5, g(x) =$
 $\frac{\quad}{\quad} x^2 - 10$

- A) $\{x \mid x \text{ is a real number and } x \neq -10\}$
 - B) $\{x \mid x \text{ is a real number}\}$
 - C) $\{x \mid x \text{ is a real number and } x \neq 10\}$
 - D) $\{x \mid x \text{ is a real number and } x \neq 10 \text{ and } x \neq \frac{5}{13}\}$
- C

357) $= -\frac{7}{\quad}, g(x) = 10x + 5x$

- $\{x \mid x \text{ is a real number and } x \neq 0\}$
- B) $x \mid x$ is a real number and $x \neq \frac{-5}{10}$
- C) $x \mid x$ is a real number and $x \neq \frac{-10}{5}$
- D) $x \mid x$ is a real number and $x \neq 0$ and $x \neq \frac{-5}{10}$

Answer: D

358) $f(x) = -\frac{8}{\quad}, g(x) = -6x x$

- A) $\{x \mid x \text{ is a real number and } x \neq -8\}$
- B) $\{x \mid x \text{ is a real number and } x \neq 8\}$
- C) $\{x \mid x \text{ is a real number and } x \neq 0\}$
- D) $\{x \mid x \text{ is a real number}\}$

Answer: C

359) $f(x) = \frac{1}{x-3}^5$, $g(x) = 6-x$

- A) $\{x \mid x \text{ is a real number and } x \neq 6\}$
- B) $\{x \mid x \text{ is a real number and } x \neq -3$
and $x \neq -6\}$
- C) $\{x \mid x \text{ is a real number}$
and $x \neq 3\}$
- D) $\{x \mid x \text{ is a real number and } x \neq 3 \text{ and } x \neq 6\}$

Answer: D

360) $f(x) = 3x + \frac{4}{x-5}$, $g(x) = 10-x$

- A) $\{x \mid x \text{ is a real number and } x \neq 5\}$
- B) $\{x \mid x \text{ is a real number}\}$
- C) $\{x \mid x \text{ is a real number and } x \neq 5 \text{ and } x \neq 10\}$
- D) $\{x \mid x \text{ is a real number and } x \neq 10\}$

Answer: C

Consider the functions f and g as shown in the graph. Answer the question.

361) What is the domain of $f + g$?

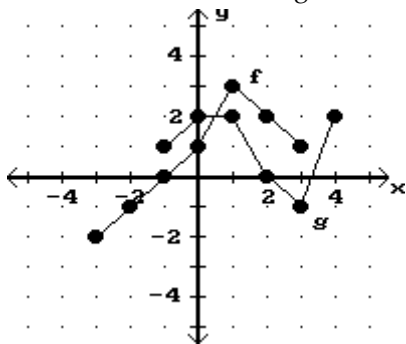

- A) $\{x \mid -1 \leq x \leq 4\}$
- B) $\{x \mid -3 \leq x \leq 3\}$
- C) $\{x \mid -3 \leq x \leq 4\}$
- D) $\{x \mid -1 \leq x \leq 3\}$

Answer: D

362) What is the domain of $f \circ g$?

f(x)

A)

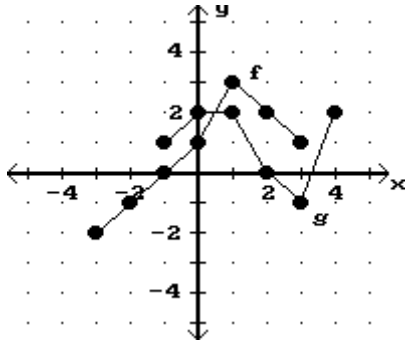

- A) $\{x \mid -3 \leq x \leq 3\}$
- B) $\{x \mid -1 \leq x \leq 3\}$
- C) $\{x \mid -3 \leq x \leq 4\}$
- D) $\{x \mid -1 \leq x \leq 4\}$

Answer: B

363) What is the domain of $f \circ g$?

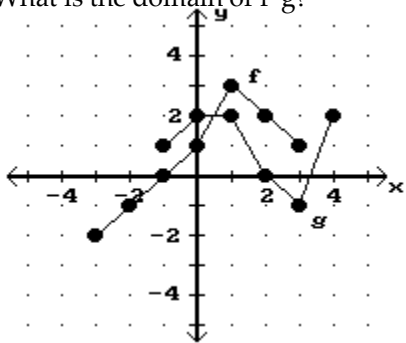

- A) $\{x \mid -1 \leq x \leq 4\}$
- B) $\{x \mid -1 \leq x \leq 3\}$
- C) $\{x \mid -3 \leq x \leq 3\}$
- D) $\{x \mid -3 \leq x \leq 4\}$

Answer: B

364) What is the domain of f/g ?

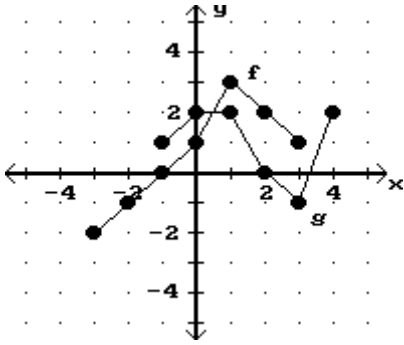

- A) $\{x \mid -1 \leq x \leq 3 \text{ and } x \neq 2\}$
- B) $\{x \mid -1 \leq x \leq 3\}$
- C) $\{x \mid -3 \leq x \leq 4\}$
- D) $\{x \mid -3 \leq x < 4 \text{ and } x \neq 1\}$

Answer: A

365) What is the domain of g/f ?

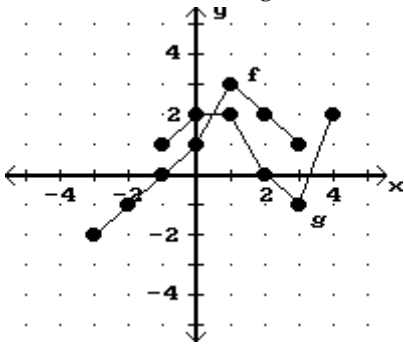

- A) $\{x \mid -1 \leq x < 3 \text{ and } x \neq 2\}$
- B) $\{x \mid -3 \leq x \leq 3\}$
- C) $\{x \mid -3 \leq x \leq 4\}$
- D) $\{x \mid -1 < x \leq 3\}$

Answer: D

366) What is the value of $(f + g)(3)$?

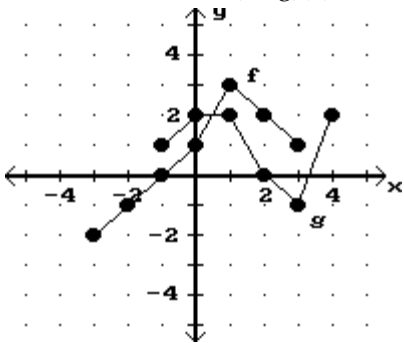

- A) 3
- B) 0

C) -1

D) 1

Answer: B

367) What is the value of $(f - g)(-1)$?

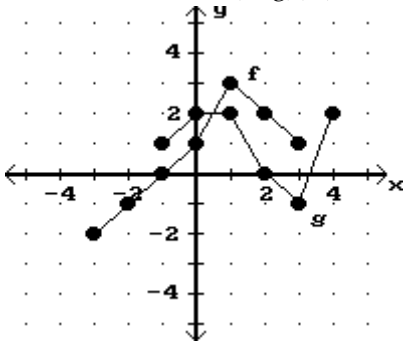

A) -1

B) 3

C) 0

D) 1

Answer: A

368) What is the value of $(f \cdot g)(1)$?

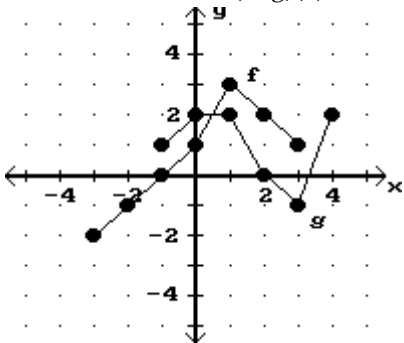

A) 6

B) 3

C) 2

D) 4

Answer: A

369) What is the value of $(f/g)(3)$?

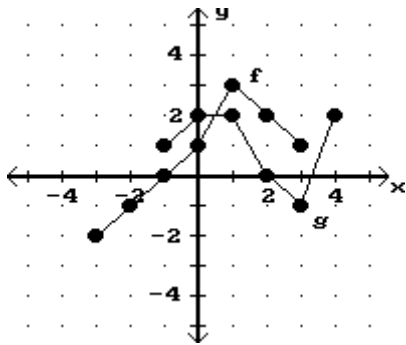

- A) -2
- B) -1
- C) 1
- D) Undefined

Answer: B

370)370)

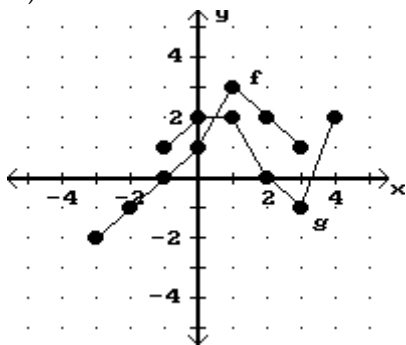

Graph $f + g$.

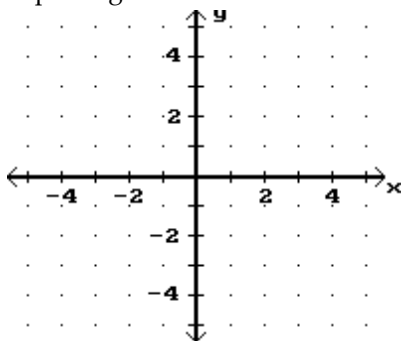

A)

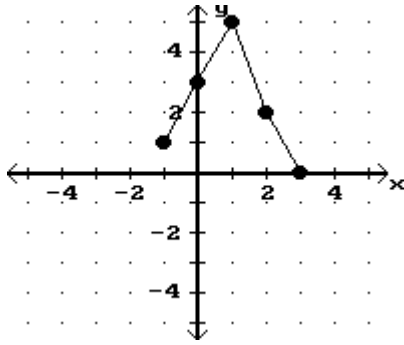

B)

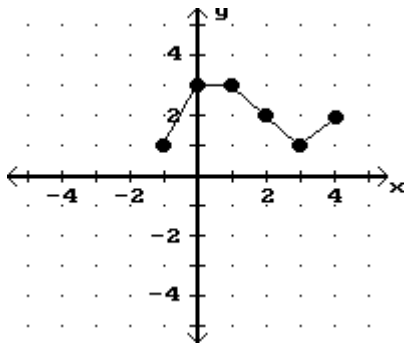

C)

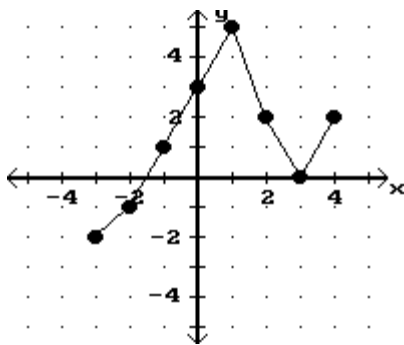

D)

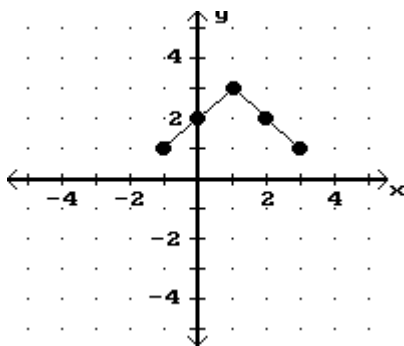

Answer: A

SHORT ANSWER. Write the word or phrase that best completes each statement or answers the question.

Provide an appropriate response.

371) Without making a drawing, explain why the graph of the equation $y = x - 5$ passes through three quadrants.

Answer: When $x < 0$, then $y < 0$ and the graph contains points in quadrant III. When $0 < x < 5$, then $y < 0$ and the graph contains points in quadrant IV. When $x > 5$, then $y > 0$ and the graph contains points in quadrant I.

372) Explain in your own words why equations of the form $y = b$ have graphs that are horizontal lines.

Answer: The second coordinate of any point on the graph is b , regardless of the first coordinate, so the graph is a line parallel to the x -axis and $|b|$ units above or below it. Thus, the graph is a horizontal line.

373) Why is the slope of a horizontal line zero?

Answer: For any two points on the line (x_1, b) and (x_2, b) , $x_1 \neq x_2$, $m = \frac{b - b}{x_1 - x_2} = \frac{0}{x_1 - x_2} = \underline{\hspace{2cm}} \underline{\hspace{2cm}} = 0$.

374) Why is the slope of a vertical line undefined?

$$\frac{y_1 - y_2}{x_1 - x_2} = \frac{y_1 - y_2}{0} \text{ Answer:}$$

For any two points on the line (a, y_1) and (a, y_2) , $y_1 \neq y_2$, $m = \frac{y_1 - y_2}{a - a} = \frac{\text{non-zero}}{0}$

375) Explain why the order in which coordinates are subtracted to find slope does not matter as long as x -coordinates are subtracted in the same order as y -coordinates.

$$\text{Answer: } m = \frac{y_2 - y_1}{x_2 - x_1} = \frac{-1 \cdot (y_1 - y_2)}{-1 \cdot (x_2 - x_1)} = \frac{y_1 - y_2}{x_1 - x_2}$$

376) Can an equation of a vertical line be written in slope-intercept form?

Answer: No; the slope of a vertical line is undefined.

377) Can the point-slope equation be used to write an equation of a vertical line? Why or why not?

Answer: No; the slope of a vertical line is undefined.

378) Describe a situation in which point-slope form would be more useful.

Answer: Point-slope form would be more useful if you wanted to find an equation of a line with a specified slope passing through a specified point that is not the y -intercept.

379) Write an equation that has no solution.

Answer: $x + 1 = x - 5$; answers may vary.

380) When solving problems, why is it necessary to check the answer in the original problem rather than in the equation to which you translated the problem?

Answer: The solution of the equation might not have meaning in the original problem. A negative number would not be a solution of a problem involving length, for example. In addition, the translation could

be incorrect and, even if it were solved correctly, would not yield a correct answer to the original problem.

381) Give a definition of Range.

Answer: The set of all values of the dependent variable (y)

382) The equation of a circle can be written in the form $x^2 + y^2 = r^2$. Is this a function? Why or Why not?

Answer: It is not a function because for $y \neq 0$, there are 2 y-values for every x-value. It fails the vertical line test.

383) The equation $y = x^2$ is satisfied by the points (2,4) and (-2,4). A horizontal line may be drawn between these two points. Is $y = x^2$ a function? Why or why not?

Answer: It is a function because each x-value gives one and only one y-value. It passes the vertical line test.

384) How does one decide whether a set of points is included in the domain of a function? In the range?

Answer: Answers will vary. A correct response should address the concepts that the domain of a function is the set of inputs that are defined for that function and the range is the set of outputs generated by the inputs from the domain.

MULTIPLE CHOICE. Choose the one alternative that best completes the statement or answers the question.

385) Determine whether the slope is positive, negative, zero or undefined.

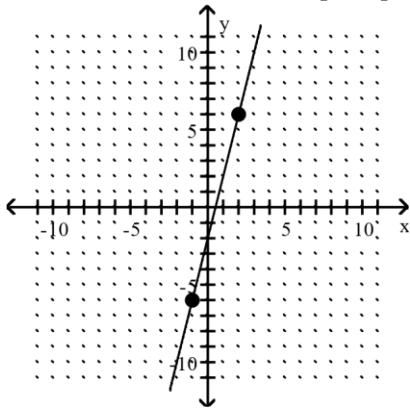

- A) Undefined
- B) Zero
- C) Positive
- D) Negative

Answer: C

386) Determine whether the slope is positive, negative, zero or undefined.

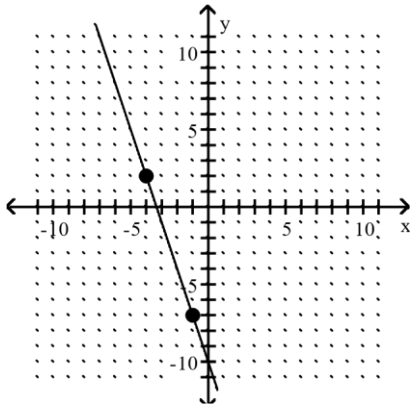

- A) Undefined
- B) Positive
- C) Negative
- D) Zero

Answer: C

387) Determine whether the slope is positive, negative, zero or undefined.

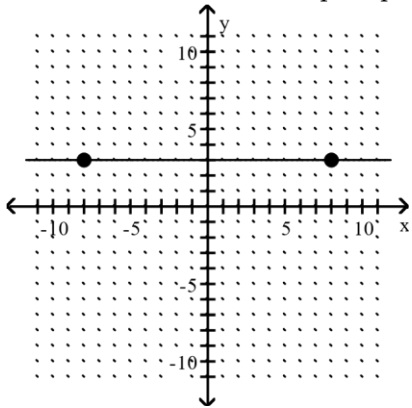

- A) Negative
- B) Positive
- C) Undefined
- D) Zero

Answer: D

388) Determine whether the slope is positive, negative, zero or undefined.

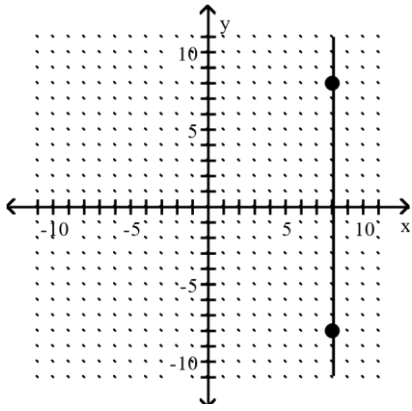

- A) Zero
- B) Undefined
- C) Positive
- D) Negative

Answer: B