

Test Bank for Intermediate Algebra for College Students 7th Edition Blitzer 0134178947 9780134178943

Full Link Download

Test Bank:

<https://testbankpack.com/p/test-bank-for-intermediate-algebra-for-college-students-7th-edition-blitzer-0134178947-9780134178943/>

Solution Manual: <https://testbankpack.com/p/solution-manual-for-intermediate-algebra-for-college-students-7th-edition-blitzer-0134178947-9780134178943/>

MULTIPLE CHOICE. Choose the one alternative that best completes the statement or answers the question.

Find the domain and range.

1) $\{(6,-8), (1,3), (-9,-9), (-2,2), (5,-6)\}$

- A) domain = $\{6, -8, 5, -6, -9\}$; range = $\{-9, 1, 3, -2, 2\}$
- B) domain = $\{6, 5, -9, 1, -2\}$; range = $\{-8, -6, -9, 3, 2\}$
- C) domain = $\{-8, -6, -9, 3, 2\}$; range = $\{6, 5, -9, 1, -2\}$
- D) domain = $\{-9, 1, 3, -2, 2\}$; range = $\{6, -8, 5, -6, -9\}$

Answer: B

2) $\{(-4,4), (3,-5), (-6,-3), (-6,-4)\}$

- A) domain = $\{-3, 4, -5, -4\}$; range = $\{-6, -4, 3\}$
- B) domain = $\{-6, -4, 3, 6\}$; range = $\{-3, 4, -5, -4\}$
- C) domain = $\{-6, -4, 3, -16\}$; range = $\{-3, 4, -5, -4\}$
- D) domain = $\{-6, -4, 3\}$; range = $\{-3, 4, -5, -4\}$

Answer: D

3) $\{(9,-6), (9,-2), (6,-9), (-11,6), (-10,-8)\}$

- A) domain = $\{9, -11, -10, 6\}$; range = $\{-2, 6, -8, -9, -6\}$
- B) domain = $\{-2, 6, -8, -9, -6\}$; range = $\{9, 9, -11, -10, 6\}$
- C) domain = $\{9, -2, -11, -10, 6\}$; range = $\{-2, 6, -8, -9, -6\}$
- D) domain = $\{9, 12, -11, -10, 6\}$; range = $\{-2, 6, -8, -9, -6\}$

Answer: A

4) $\{(6,-6), (-4,7), (9,8), (9,-1)\}$

- A) domain = $\{9, -4, 6, 19\}$; range = $\{8, 7, -6, -1\}$
- B) domain = $\{8, 7, -6, -1\}$; range = $\{9, -4, 6\}$
- C) domain = $\{9, -4, 6, -9\}$; range = $\{8, 7, -6, -1\}$
- D) domain = $\{9, -4, 6\}$; range = $\{8, 7, -6, -1\}$

Answer: D

5) $\{(-2,-1), (-8,-7), (12,-2), (8,6)\}$

- A) domain = {8, -8, -2, 12}; range = {6, 1, -7, -1, -2}
- B) domain = {8, -8, -2, 12}; range = {6, 6, -7, -1, -2}
- C) domain = {8, -8, -2, 12}; range = {6, -7, -1, -2}
- D) domain = {6, -7, -1, -2}; range = {8, -8, -2, 12}

Answer: C

6) $\{(-3, 10), (-2, 5), (0, 1), (2, 5), (4, 17)\}$

- A) domain: {10, 5, 1, 17}; range: {-3, -2, 0, 2, 4}
- B) domain: {10, 5, 1, 17}; range: {-3, -2, 2, 4}
- C) domain: {-3, -2, 2, 4}; range: {10, 5, 1, 17}
- D) domain: {-3, -2, 0, 2, 4}; range: {10, 5, 1, 17}

Answer: D

7) $\{(41, -4), (5, -3), (5, 0), (14, 3), (30, 5)\}$

- A) domain: {41, 14, 5, 30}; range: {-4, -3, 3, 5}
- B) domain: {-4, -3, 3, 5}; range: {41, 14, 5, 30}
- C) domain: {-4, -3, 0, 3, 5}; range: {41, 14, 5, 30}
- D) domain: {41, 14, 5, 30}; range: {-4, -3, 0, 3, 5}

Answer: D

Decide whether the relation is a function.

8) $\{(-3, 5), (1, 2), (6, -4), (8, 3), (10, 7)\}$

- A) not a function
- B) function

Answer: B

9) $\{(-3, -9), (-1, -8), (4, 9), (5, 1)\}$

- A) function
- B) not a function

Answer: A

10) $\{(-8, 9), (-4, 3), (-2, -9), (4, 7)\}$

- A) not a function
- B) function

Answer: B

11) $\{(-4, 6), (-1, 6), (2, 9), (6, 5)\}$

- A) function
- B) not a function

Answer: A

12) $\{(-3, 5), (1, 5), (5, 5), (8, -6), (10, -2)\}$

- A) function
- B) not a function

Answer: A

13) $\{(-5, -2), (-2, -4), (3, -1), (3, 7)\}$

A) function

B) not a function Answer: B

14) $\{(-3, 6), (-1, -6), (2, 9), (2, 4)\}$

A) function

B) not a function Answer: B

15) $\{(-9, 3), (-9, 7), (-1, 5), (5, 1), (9, -6)\}$

A) function

B) not a function Answer: B

16) $\{(3, 6), (3, 4), (5, -2), (7, -5), (11, 6)\}$

A) not a function B) function

Answer: A

17) $\{(-7, 1), (-7, 4), (1, -8), (3, 9), (9, -3)\}$

A) not a function

B) function

Answer: A

18) Women's Shoe Sizes

USA	3	4	5	6	7	8	9
Japan	20	21	22	23	24	25	26

A) function

B) not a function

Answer: A

19) Tallest Roller Coasters in U.S. Amusement Parks

Amusement Park Name	Park A	Park A	Park B	Park C	Park B	Park A
Coaster Height (feet)	72	69	65	64	60	57

A) not a function B) function

Answer: A

Find the indicated function value.

20) Find $f(2)$ when $f(x) = x^2 + 3x - 3$.

A) 13

B) -5

C) 1

D) 7

Answer: D

21) Find $f(4)$ when $f(x) = 5x^2 + 2x + 2$.

- A) 74
- B) 90
- C) 26
- D) 86

Answer: B

22) Find $f(1)$ when $f(x) = 8x - 6$.

- A) -14
- B) 7.4
- C) 14
- D) 2

Answer: D

23) Find $f(6)$ when $f(x) = 6$.

- A) -18
- B) 6
- C) 0
- D) -3

Answer: B

24) Find $f(0)$ when $f(x) = x^2 - 5x - 4$.

- A) 0 B) -4
- C) 16
- D) 4

Answer: B

25) Find $f(-2)$ when $f(x) = \frac{x^2 - 2}{x^3 - 2x}$.

- A) $-\frac{1}{4}$
- B) -1
- C) $-\frac{1}{5}$
- D) $-\frac{1}{2}$

Answer: D

$$= x^3 - 5. \text{ ———}$$

26) Find $f(2)$ when $f(x)$

$$x^2 - 3$$

- A) 3
- B) 8
- C) -1
- D) $\frac{3}{4}$

Answer: A

27) Find $g(a - 1)$ when $g(x) = 4x - 4$.

- A) $4a - 12$
- B) $4a - 8$ C) $4a$
- D) $4a - 4$

Answer: B

28) Find $g(a + 1)$ when $g(x) = \frac{1}{2}x - 5$.

- A) $\frac{a - 19}{2}$
- B) $\frac{a + 9}{2}$
- C) $\frac{a - 8}{2}$
- D) $\frac{a - 9}{2}$

Answer: D

29) Find $r(a - 2)$ when $r(x) = \frac{5}{x - 3}$.

- A) $-\frac{5}{3}a + \frac{10}{3}$
- B) $-\frac{5}{a - 3}$
- C) $\frac{3}{a - 3}$
- D) $a - 5$

Answer: D

30)30)

x	f(x)
-5	5
-2	11
0	15
2	19
5	25

Find $f(2)$

A) 25

B) 19

C) 5

D) 11

Answer: B

31)31)

x	f(x)
-3	-3
-2	2
0	12
2	22
3	27

For what value of x is $f(x) = 12$?

A) 0

B) 2

C) -3

D) -2

Answer: A

Graph the given functions on the same rectangular coordinate system. Describe how the graph of g is related to the graph of f .

32) $f(x) = x$, $g(x) = x + 4$

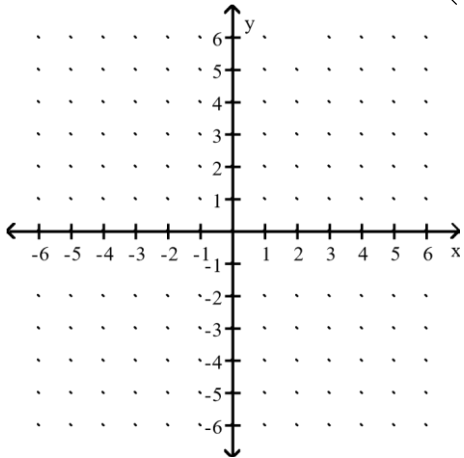

A) g shifts the graph of f
vertically up 4 units

g shifts the graph of f vertically

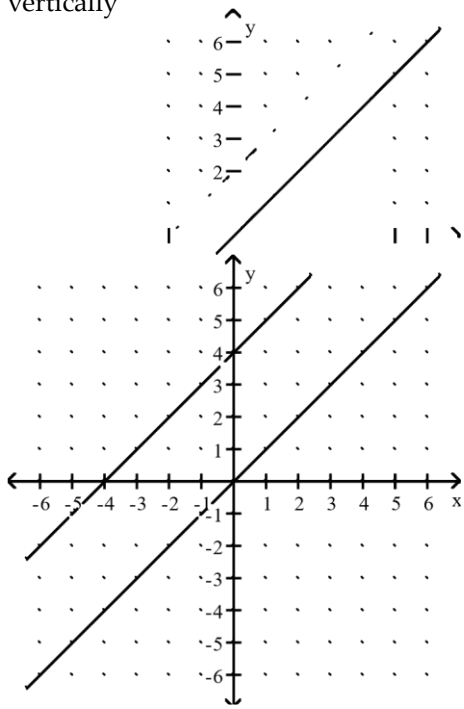

B) g shifts the graph of f vertically up 4 units

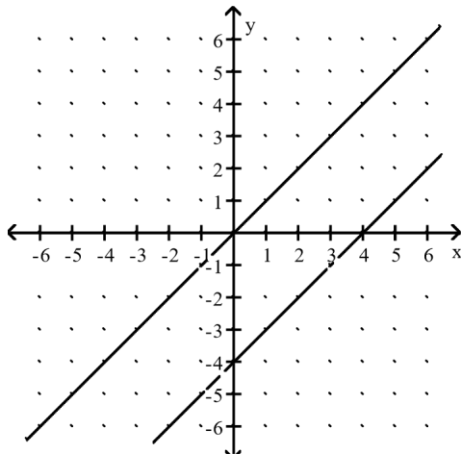

g shifts the graph of f vertically

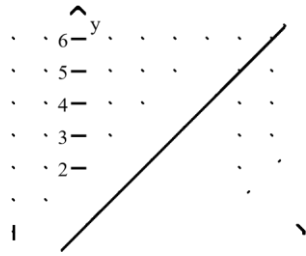

C)

down 4 units

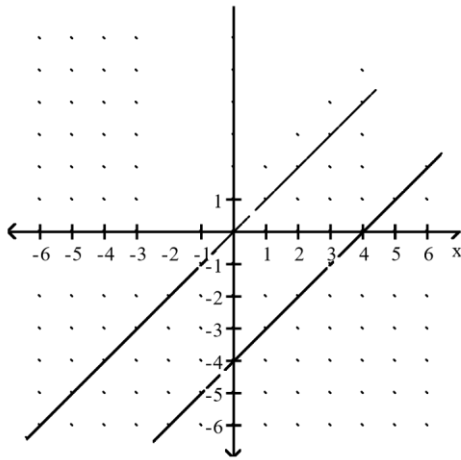

D) g shifts the graph of f vertically down 4 units

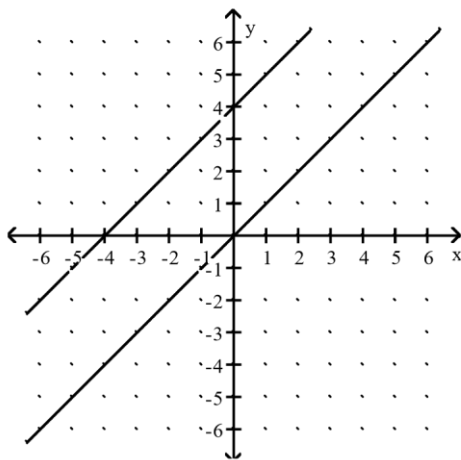

Answer: A

g shifts the graph of f
vertically

33) $f(x) = x$, $g(x) = x - \frac{1}{2}$

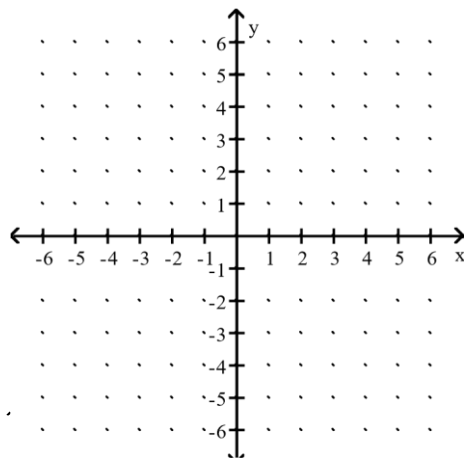
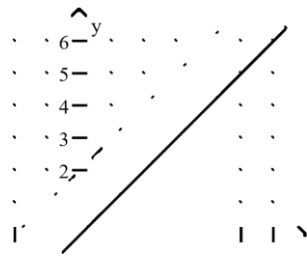

g shifts the graph of f vertically

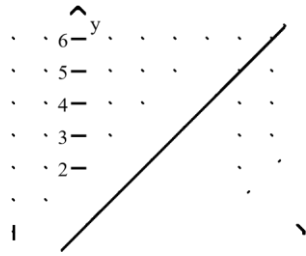

A)

down 2 units

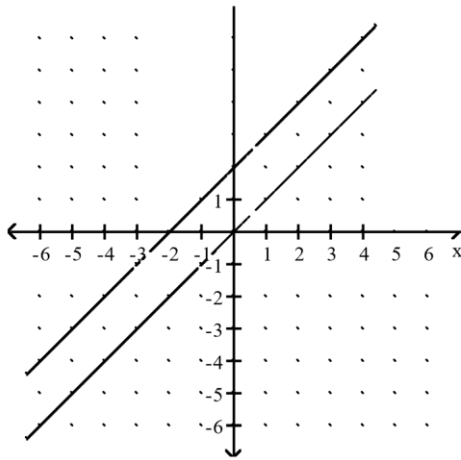

B) g shifts the graph of f vertically down 2 units

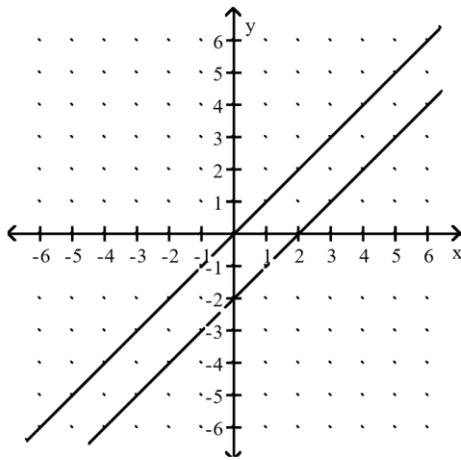

C) g shifts the graph of f vertically up 2 units

g shifts the graph of f
vertically

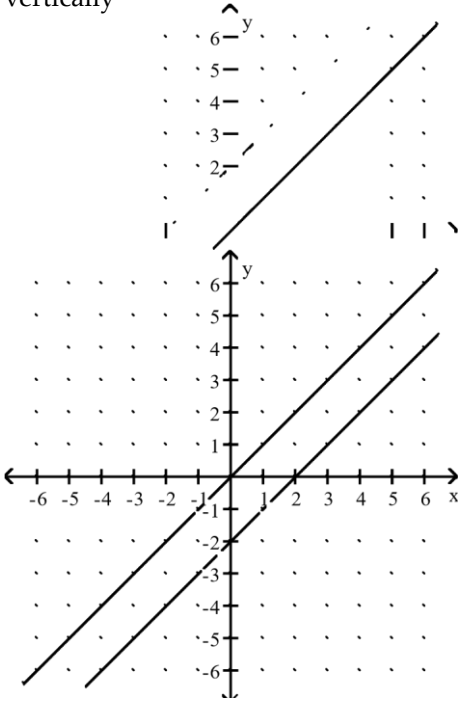

g shifts the graph of f vertically

D) up 2 units

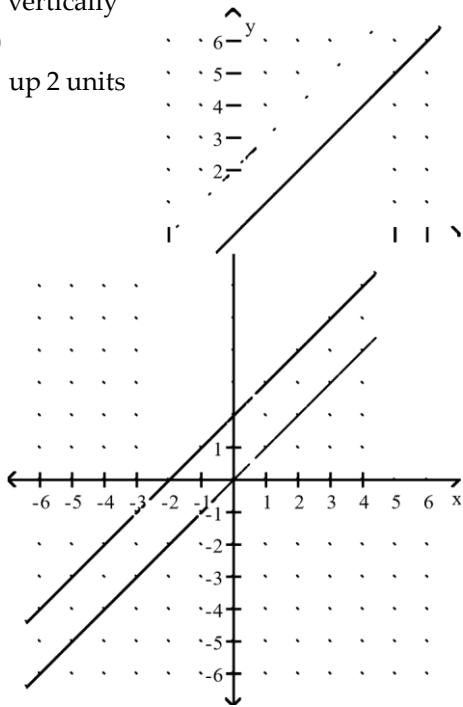

Answer: B

34) $f(x) = -4x$, $g(x) = -4x - 4$

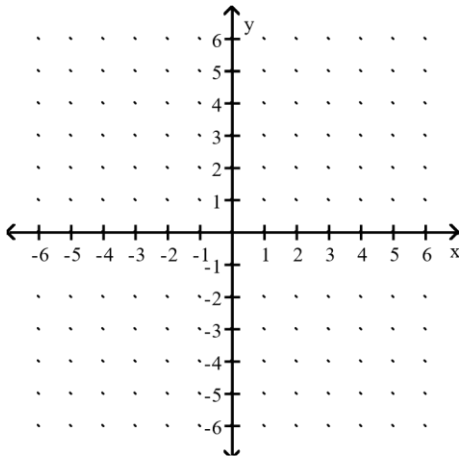

A) g shifts the graph of f vertically down 4 units

g shifts the graph of f
vertically

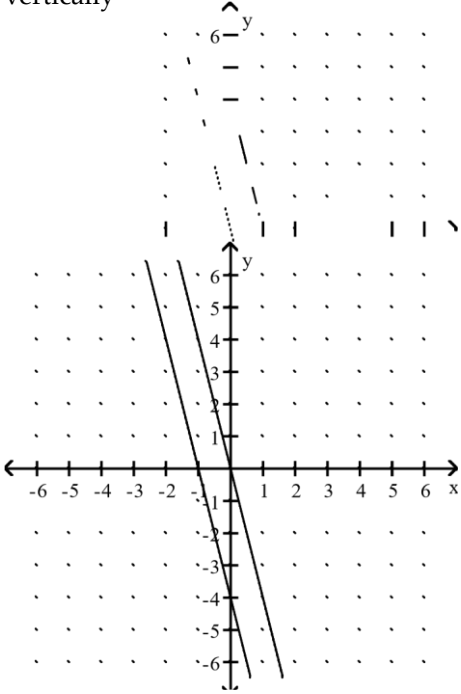

B)

up 4 units

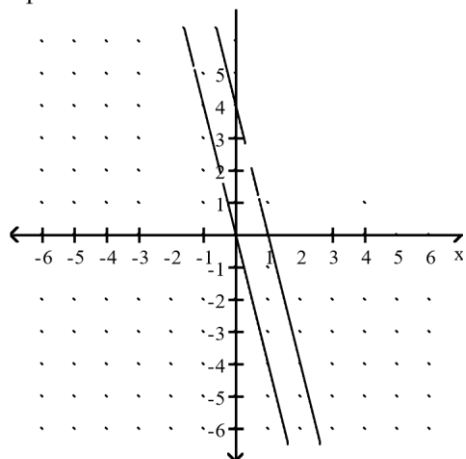

C) g shifts the graph of f vertically

down 4 units

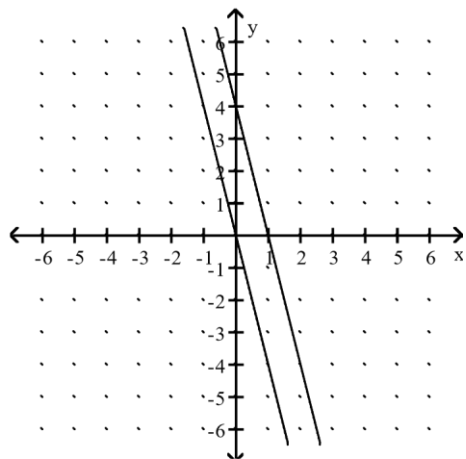

D) g shifts the graph of f

vertically up 4 units

g shifts the graph of f
vertically

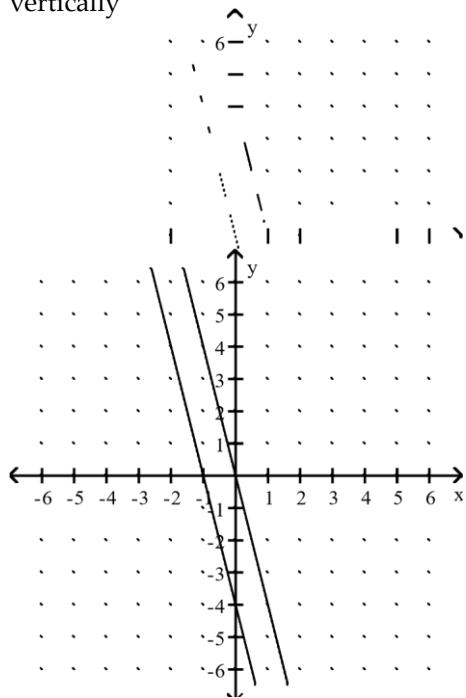

Answer: A

35) $f(x) = -4x$, $g(x) = -4x + 3$

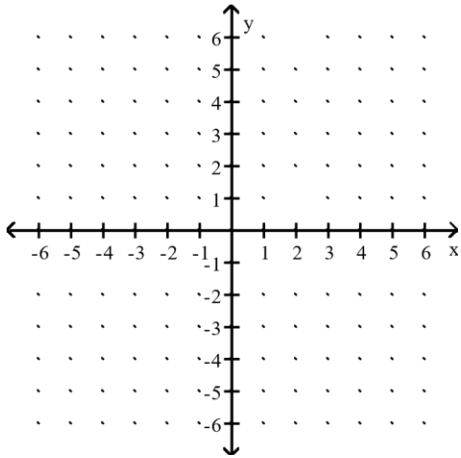

A) g shifts the graph of f
vertically up 3 units

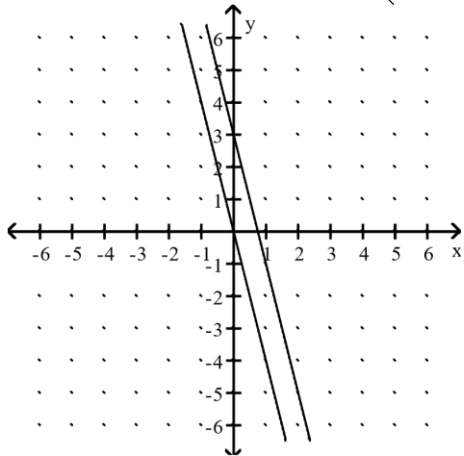

B) g shifts the graph of f vertically up 3 units

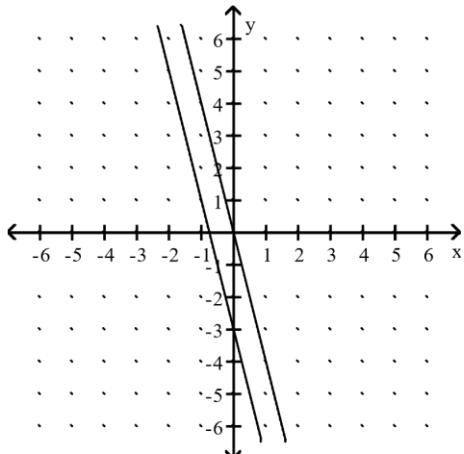

g shifts the graph of f vertically

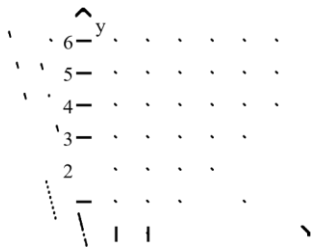

C) down 3 units

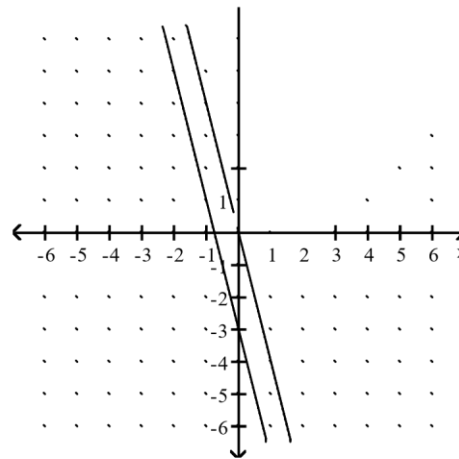

D) g shifts the graph of f vertically down 3 units

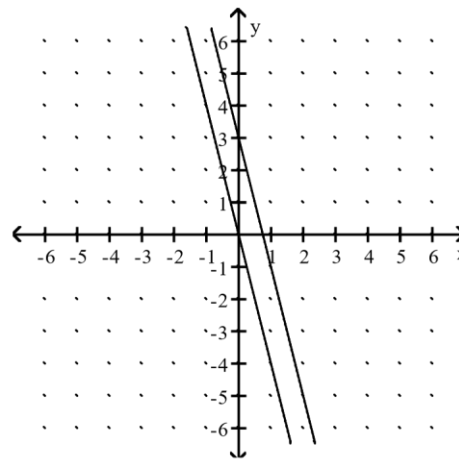

Answer: A

36) $f(x) = |x|$, $g(x) = |x| + 2$

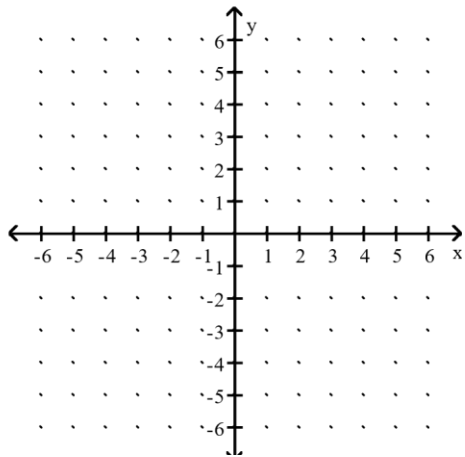

g shifts the graph of f vertically

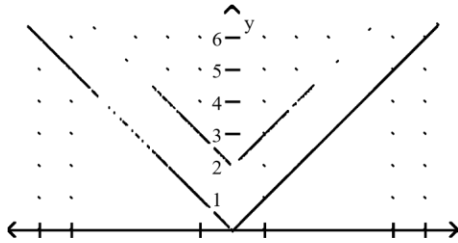

A)

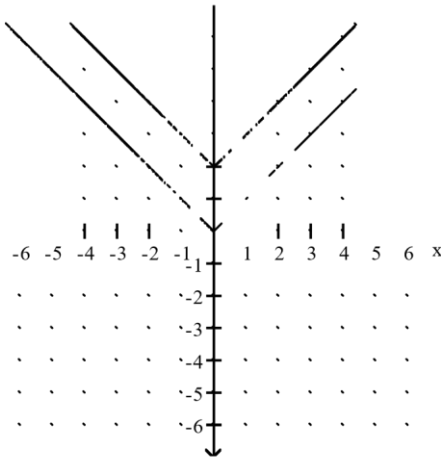

B) g shifts the graph of f vertically

up 2 units

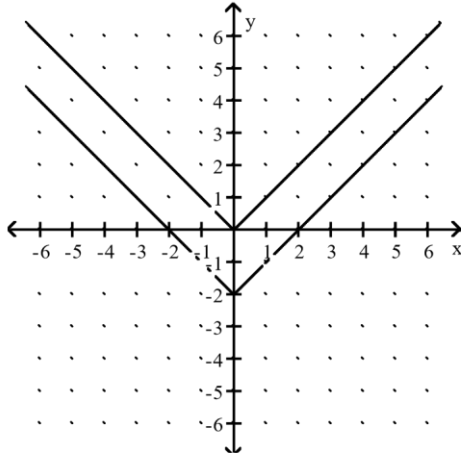

C) g shifts the

graph of f

vertically

down 2

units

g shifts the graph of f vertically

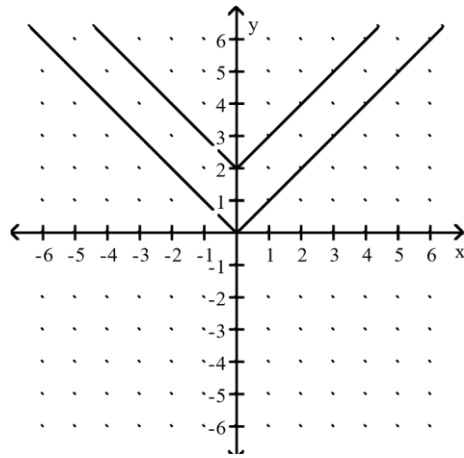
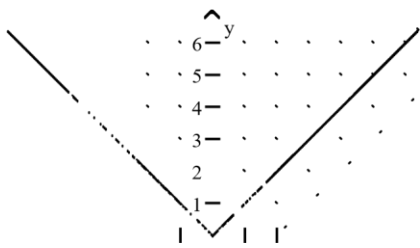

D) down 2 units

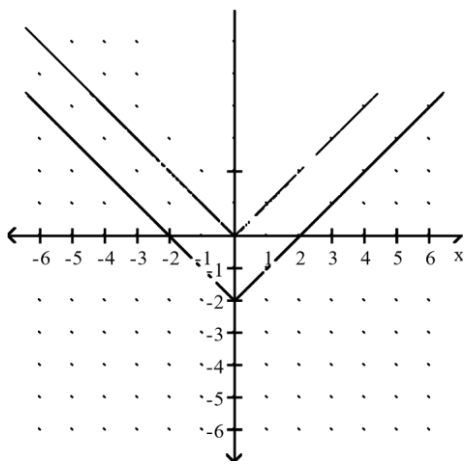

Answer: A

37) $f(x) = |x|$, $g(x) = |x| - 2$

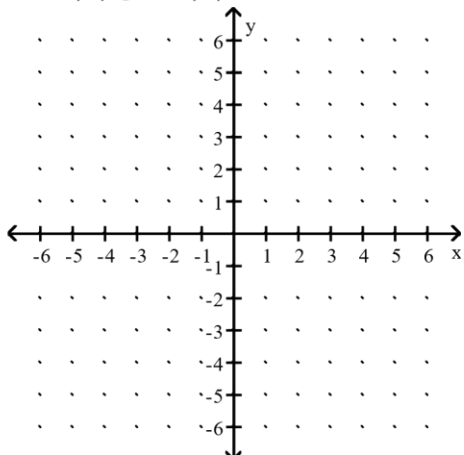

A) g shifts the graph of f vertically down 2 units

g shifts the graph of f vertically

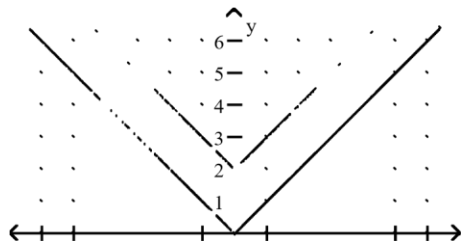

up 2 units

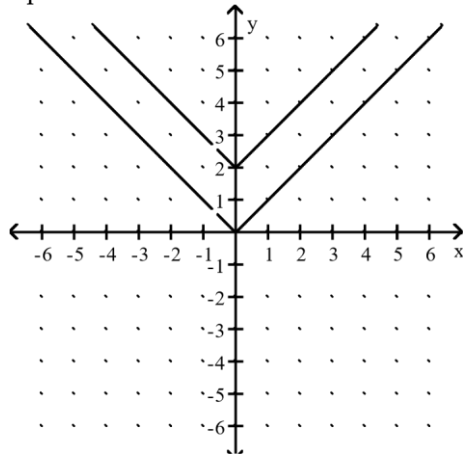

g shifts the graph of f

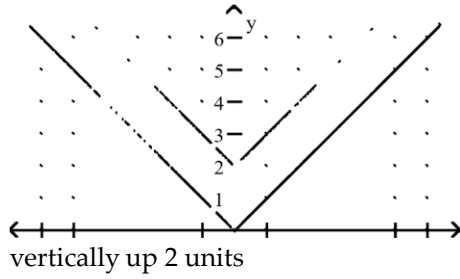

B)

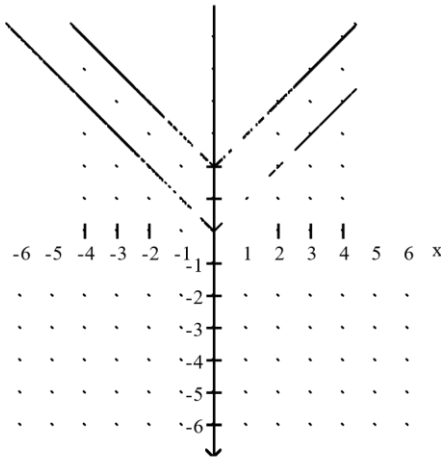

C) g shifts the graph of f vertically up 2 units

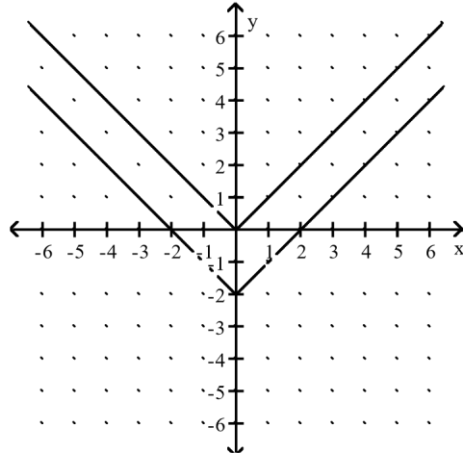

D) g shifts the graph of f vertically down 2 units

g shifts the graph of f

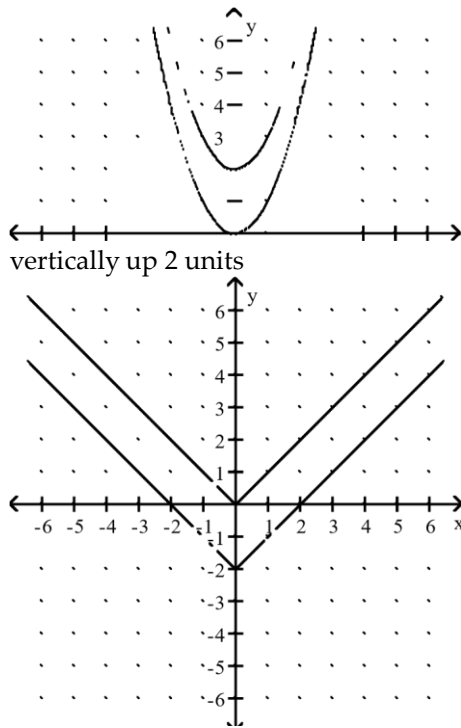

Answer: D

38) $f(x) = x^2$, $g(x) = x^2 + 2$

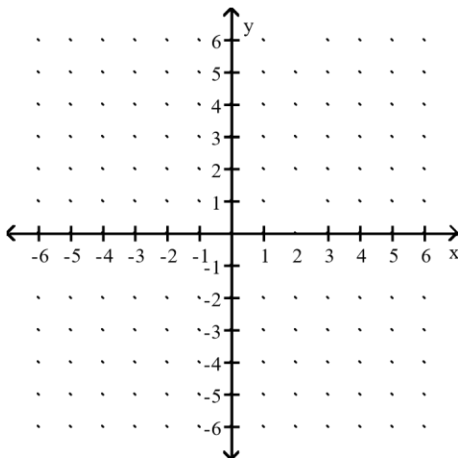

A) g shifts the graph of f
vertically up 2 units

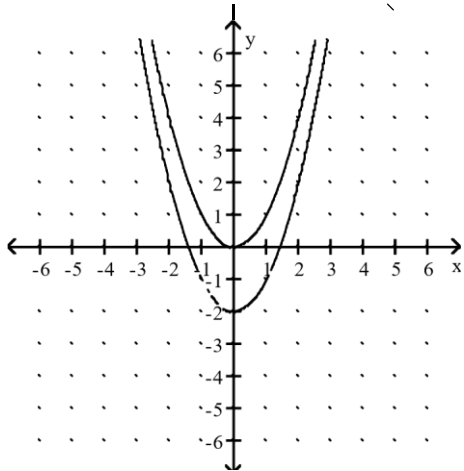

B) g shifts the graph of f
vertically down 2 units

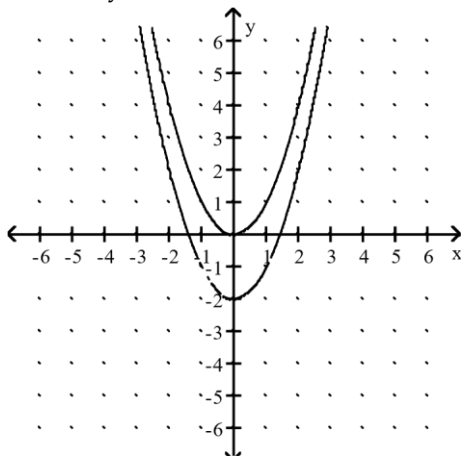

g shifts the graph of f

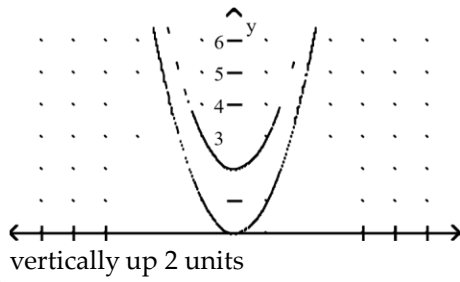

C)

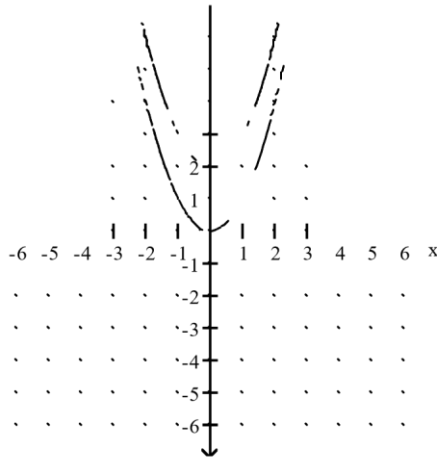

D) g shifts the graph of f vertically down 2 units

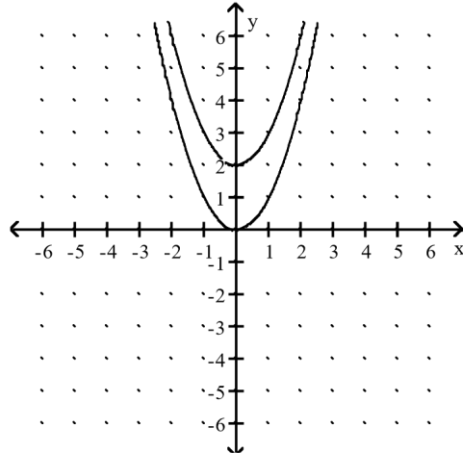

Answer: C

39) $f(x) = x^2$, $g(x) = x^2 - 3$

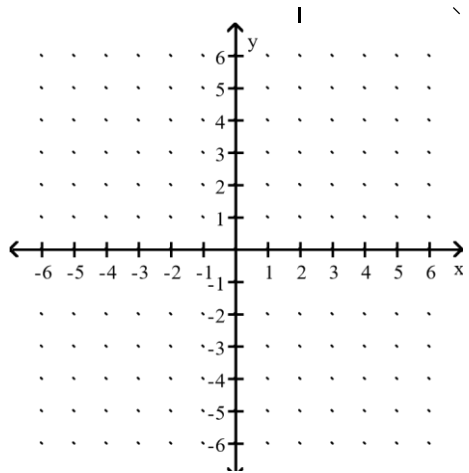

g shifts the graph of f

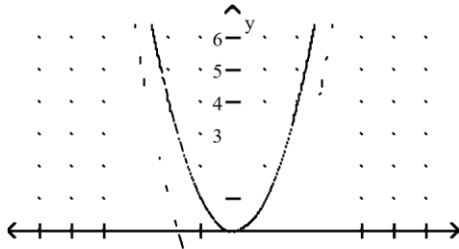

vertically up units

A)

3

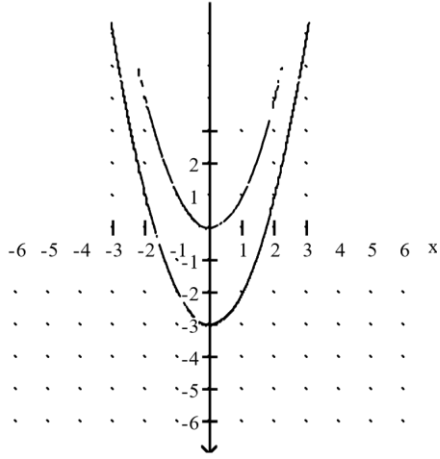

B) g shifts the graph of f vertically down 3 units

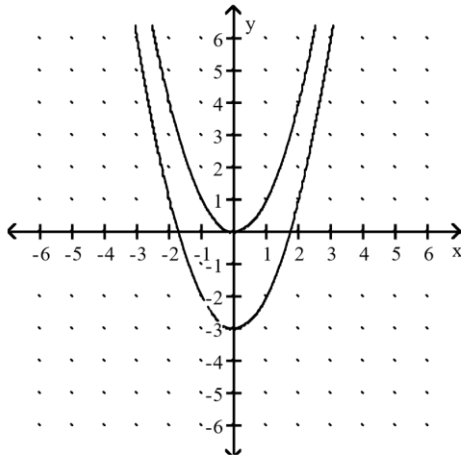

C) g shifts the graph of f vertically down 3 units

g shifts the graph of f

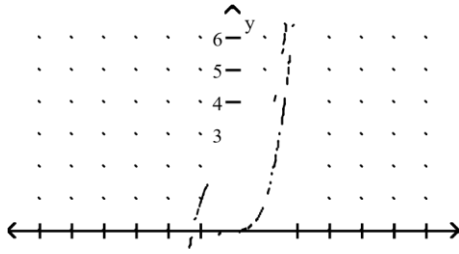

vertically down units

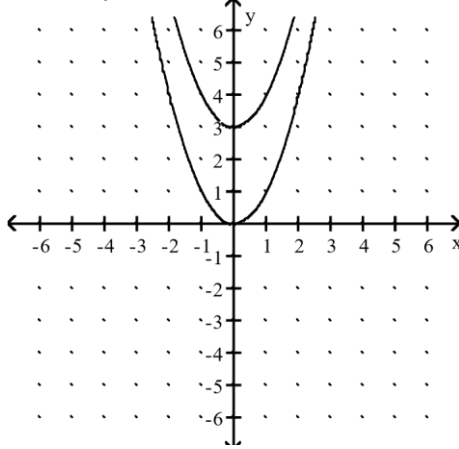

D)

3

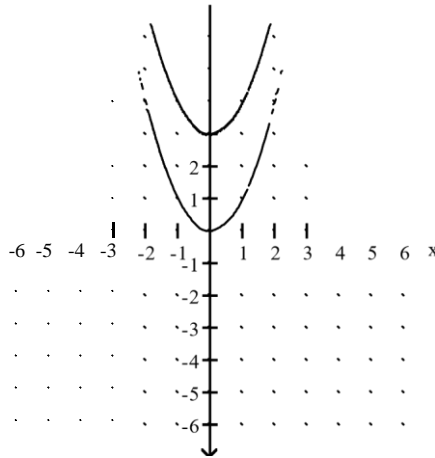

Answer: B

40) $f(x) = x^3$, $g(x) = x^3 + 2$

g shifts the graph of f

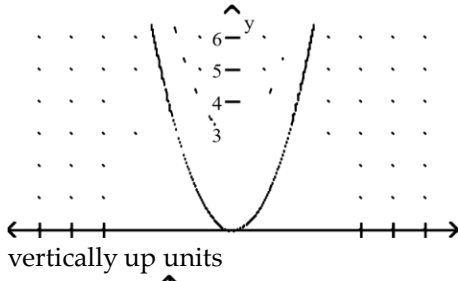

vertically up units

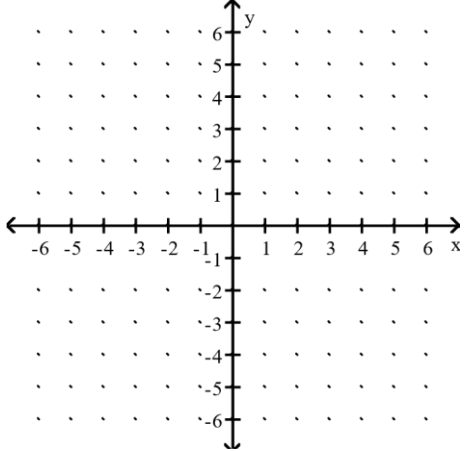

A) g shifts the graph of f

vertically up 2 units

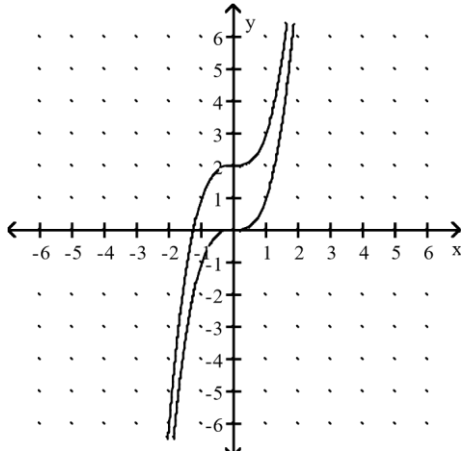

g shifts the graph of f

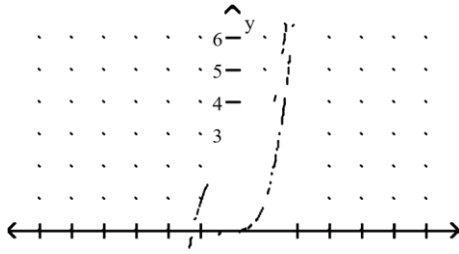

vertically down units

B)

2

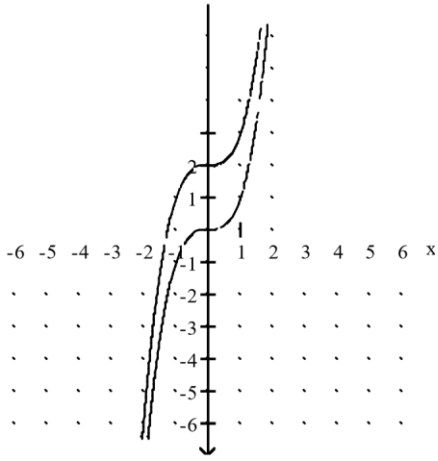

C) g shifts the graph of f vertically
up 2 units

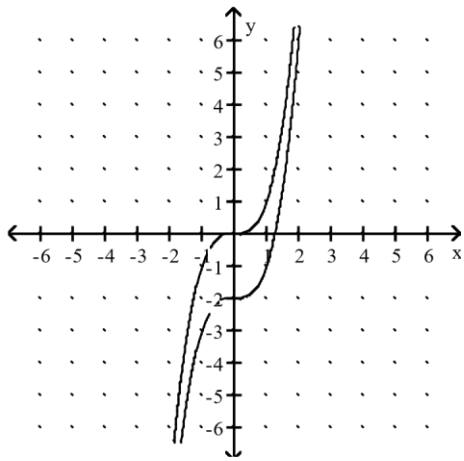

D) g shifts the graph of f
vertically down 2 units

g shifts the graph of f

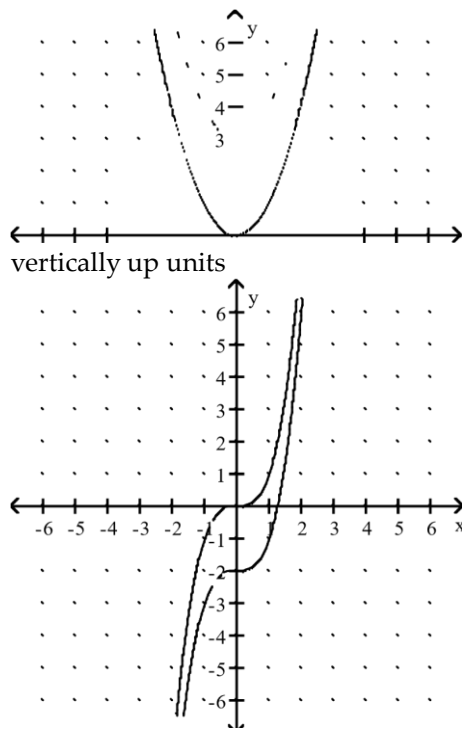

Answer: A

41) $f(x) = x^3$, $g(x) = x^3 - 4$

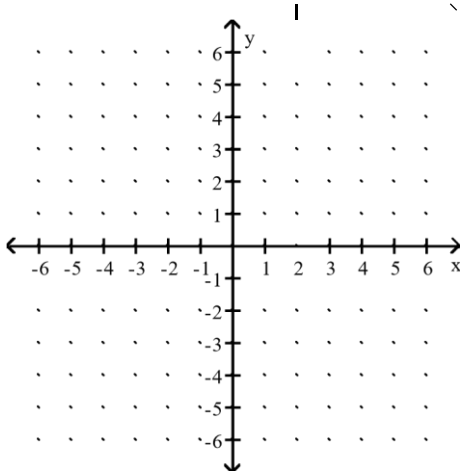

A) g shifts the graph of f
vertically up 4 units

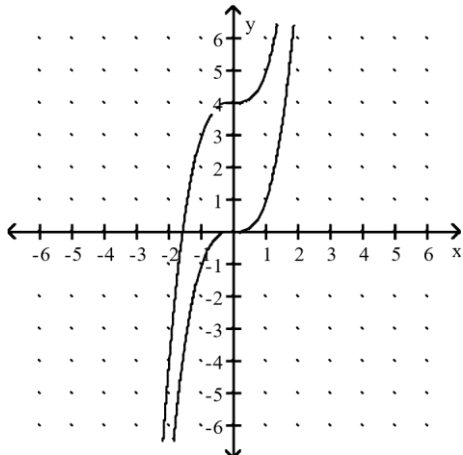

B) g shifts the graph of f
vertically up 4 units

g shifts the graph of f

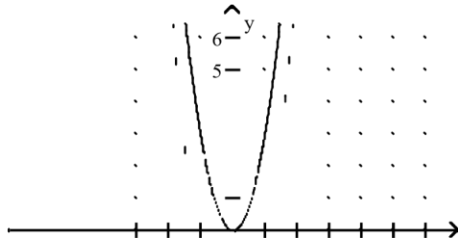

vertically

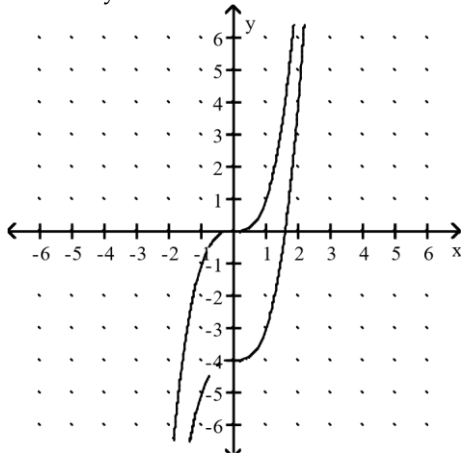

g shifts the graph of f

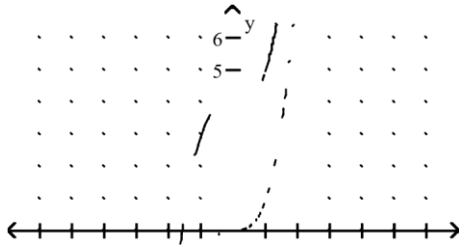

vertically down units

C)

4

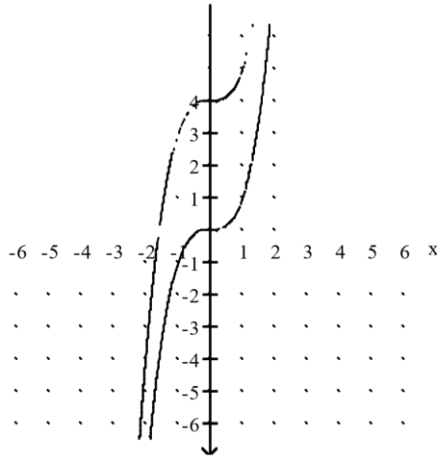

D) g shifts the graph of f vertically down 4 units

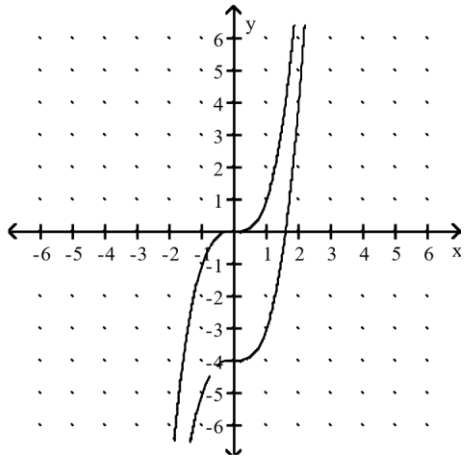

g shifts the graph of f

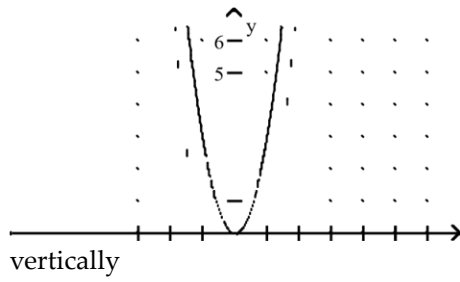

Answer: D

42) $f(x) = 3x^2$, $g(x) = 3x^2 - 4$

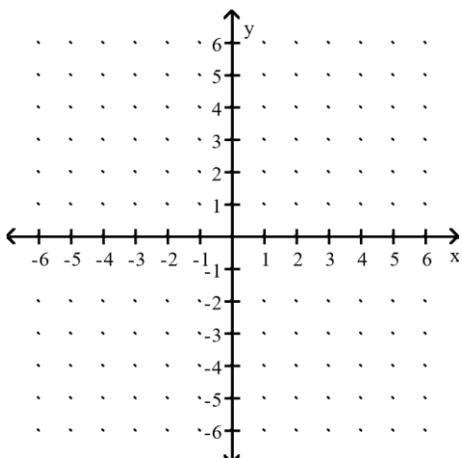

g shifts the graph of f

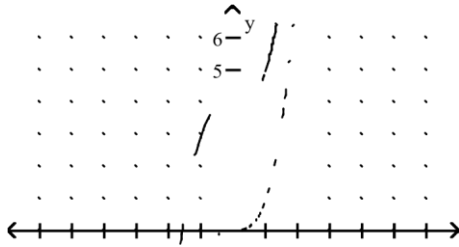

vertically down units

A)

up 4 units

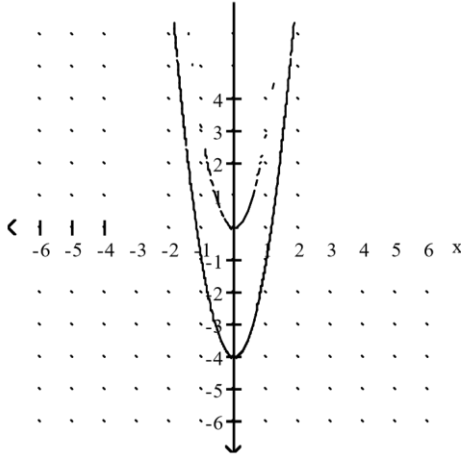

B) g shifts the graph of f vertically

up 4 units

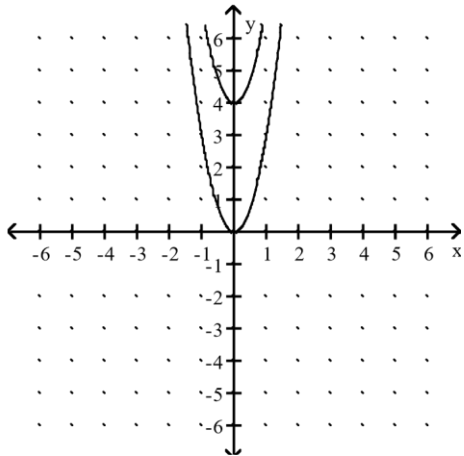

C) g shifts the graph of f

vertically down 4 units

g shifts the graph of f

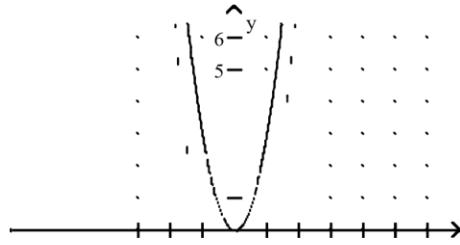

vertically

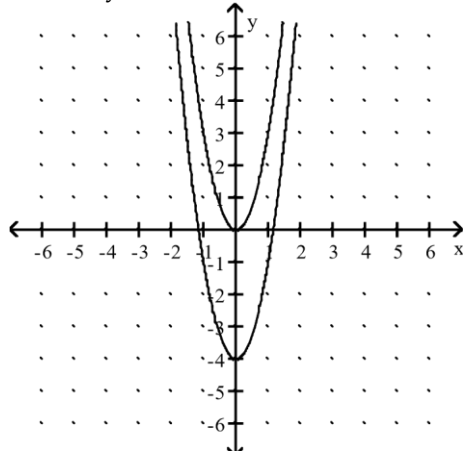

g shifts the graph of f vertically

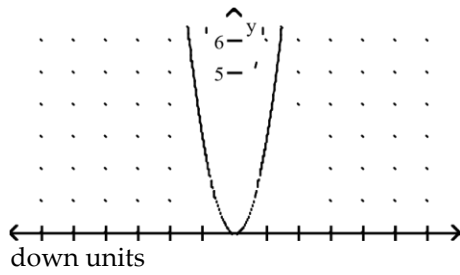

D)

4

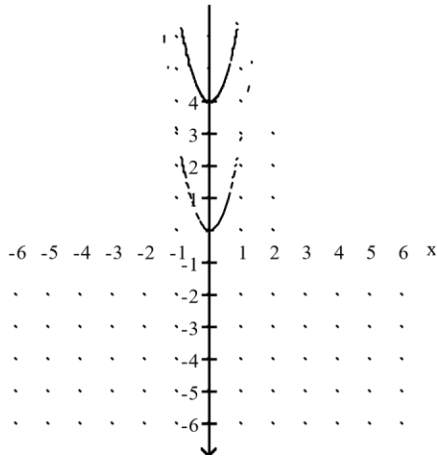

Answer: C

43) $f(x) = 2x^2$, $g(x) = 2x^2 + 3$

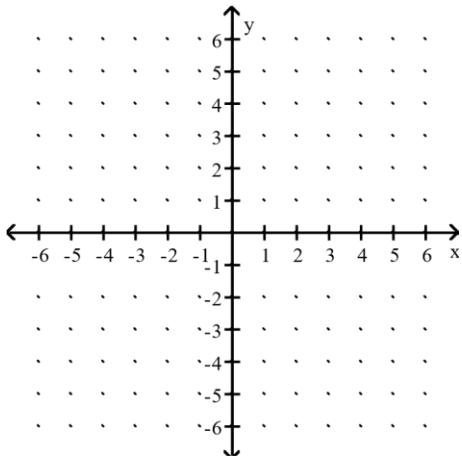

A) g shifts the graph of f vertically
down 3 units

g shifts the graph of f vertically

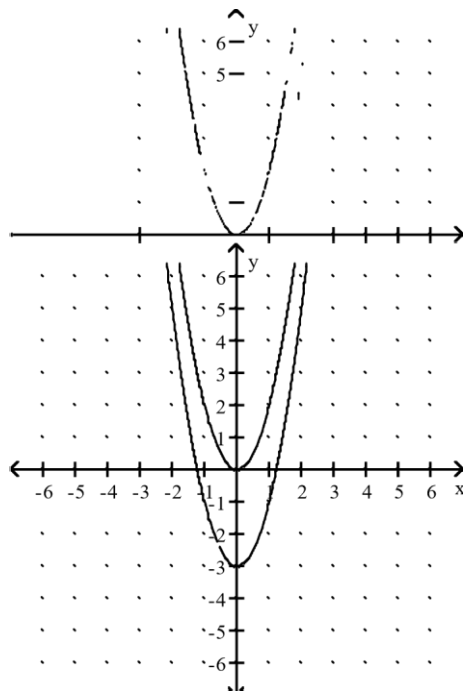

B)
up 3 units

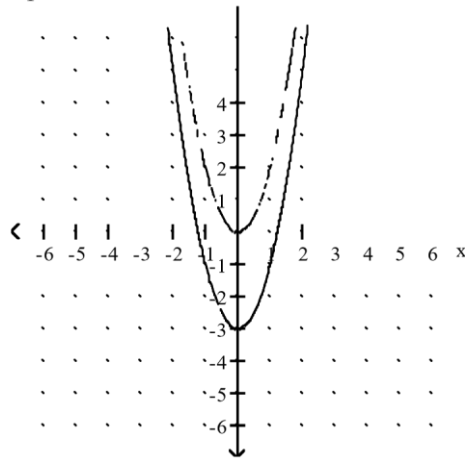

C) g shifts the graph of f vertically
down 3 units

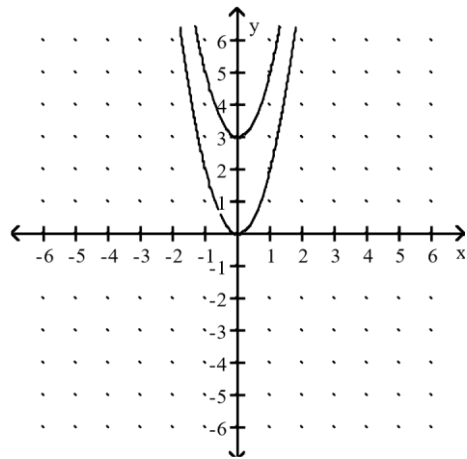

D) g shifts the graph of f vertically
up 3 units

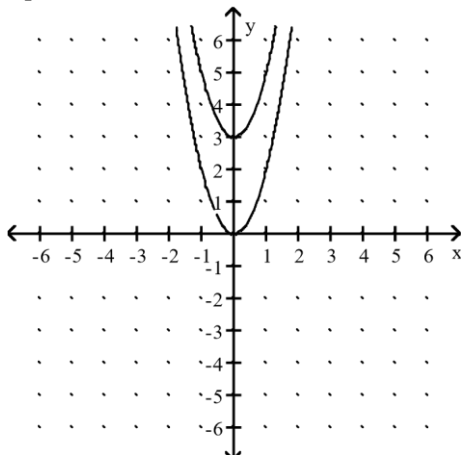

Answer: D

Use the
whether or
function.

44)

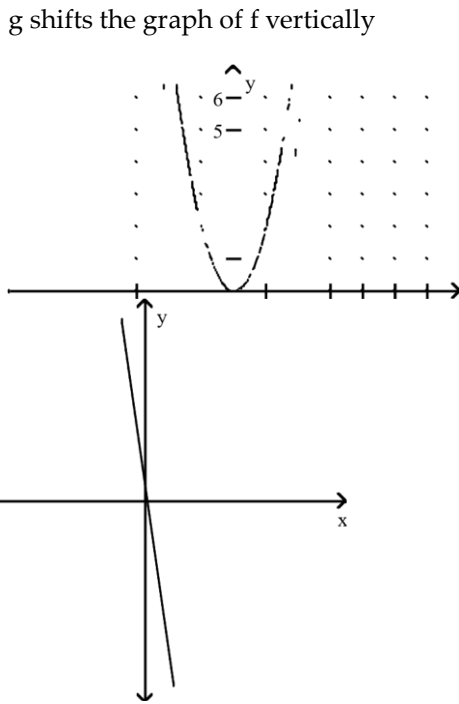

- A) not a function
 - B) function
- Answer: B

45)

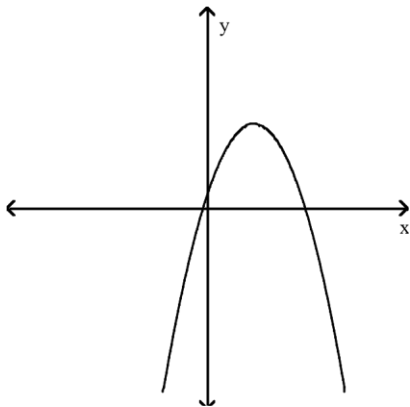

- A) not a function
 - B) function
- Answer: B

46)

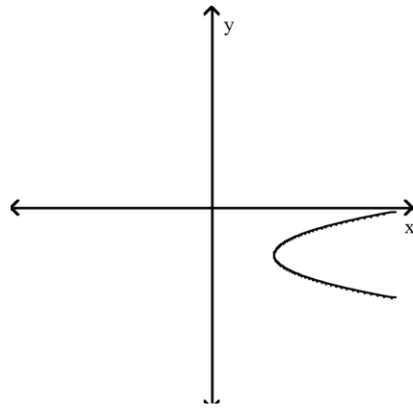

A) function

B) not a function

Answer: B

47)

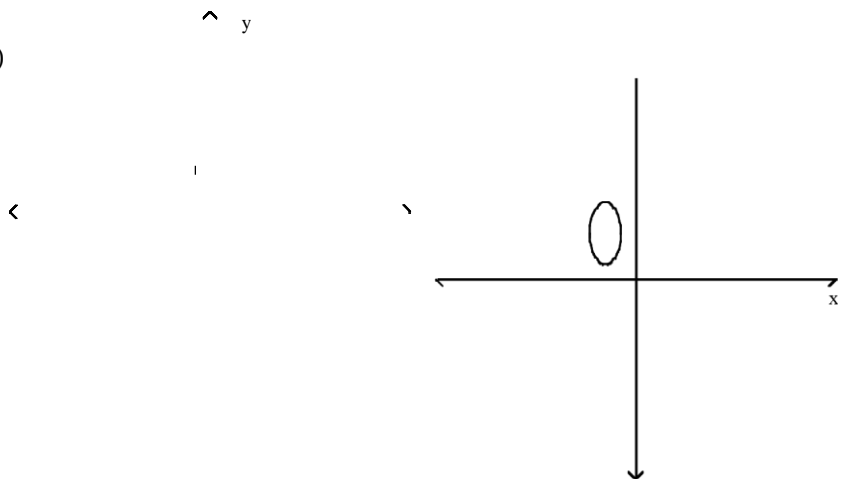

A) function
B) not a
function Answer:
B

48)

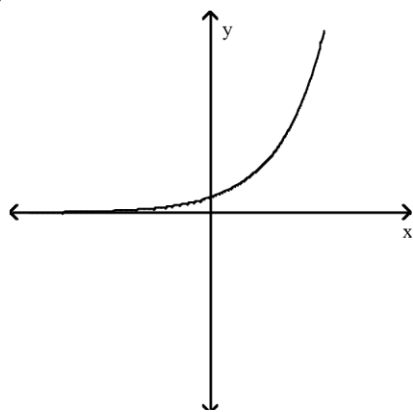

A) function
B) not a function
Answer: A

49)

A) not a function
B) function
Answer: B

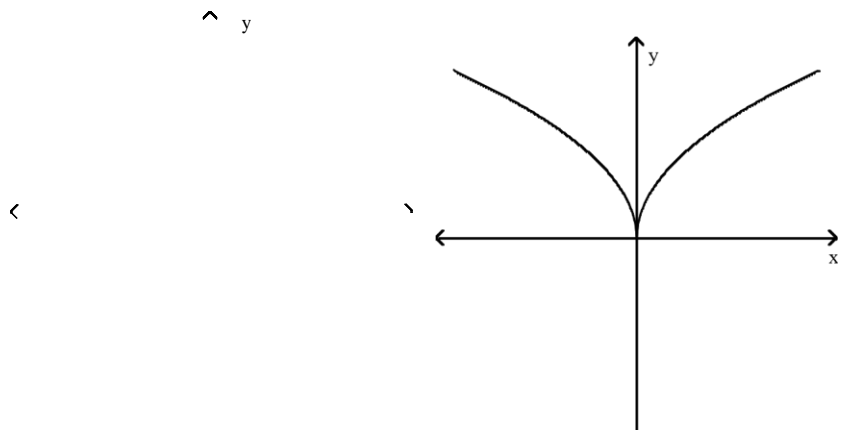

50)

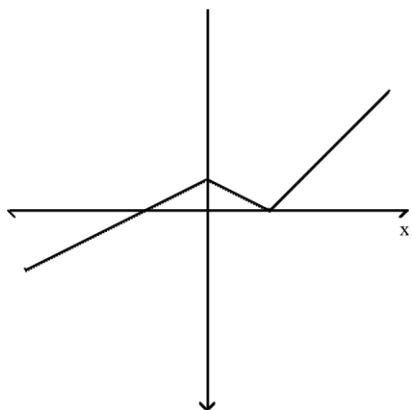

- A) not a function
 - B) function
- Answer: B

51)

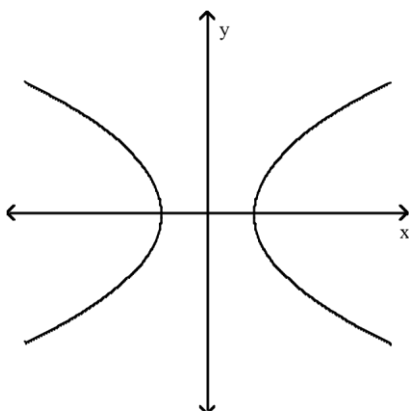

- A) function
 - A) not a function
 - B) function
- Answer: B

B) not a function
 Answer:
 B

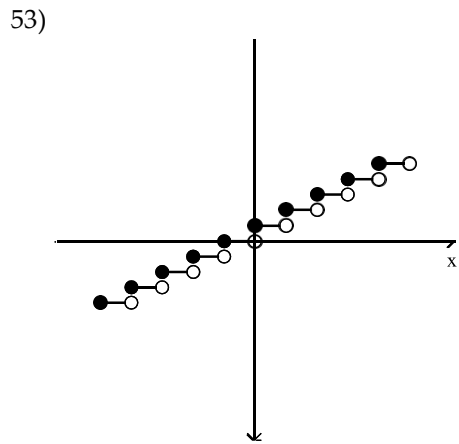
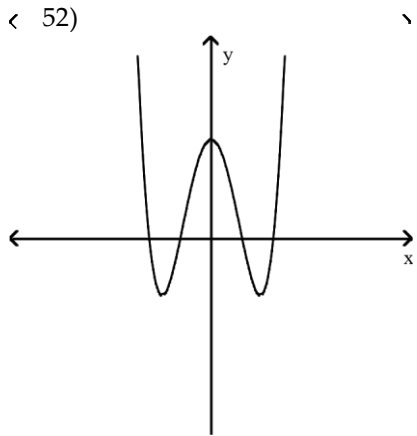

A) function
 B) not a function
 Answer: A

54)

A) not a function
 B) function
 Answer: B

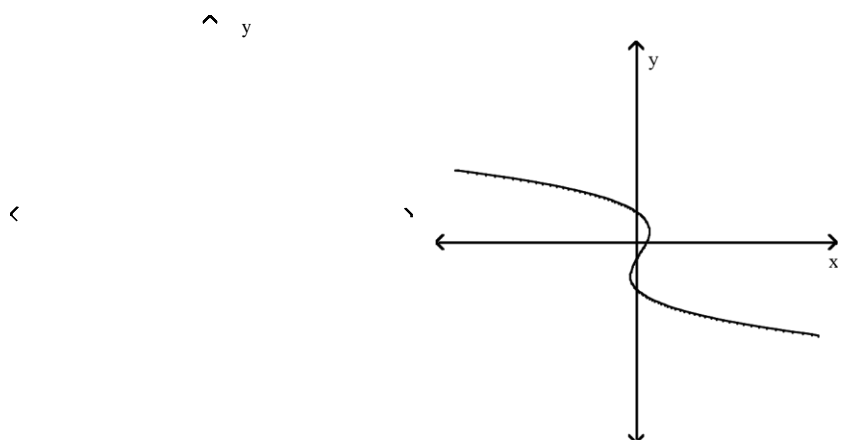

A) function
 B) not a function
 Answer: B

55)

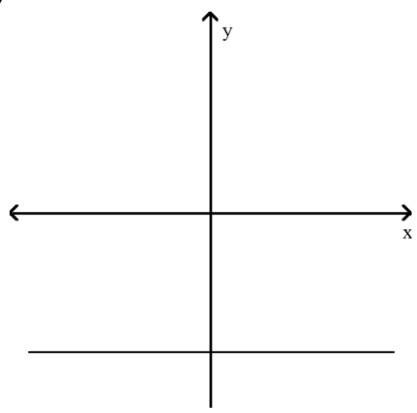

A) not a function
 B) function
 Answer: B

56)

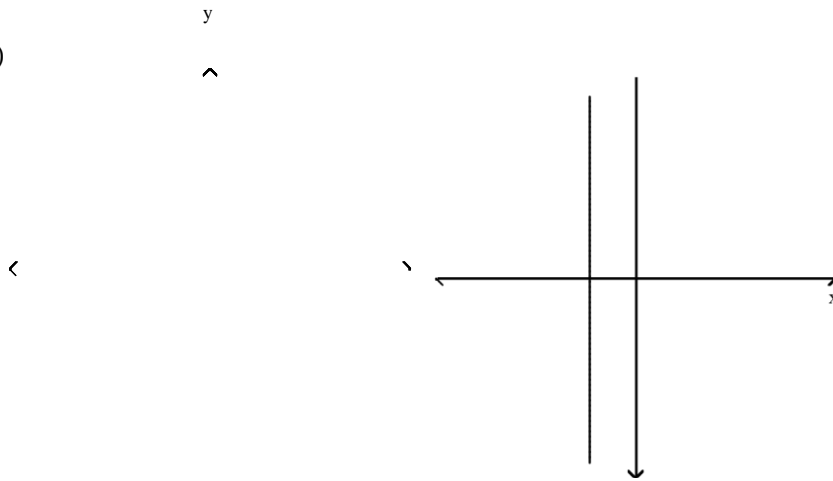

- A) not a function
 - B) function
- Answer: A

Use the graph to find the indicated function value.

57) $y = f(x)$. Find $f(4)$.

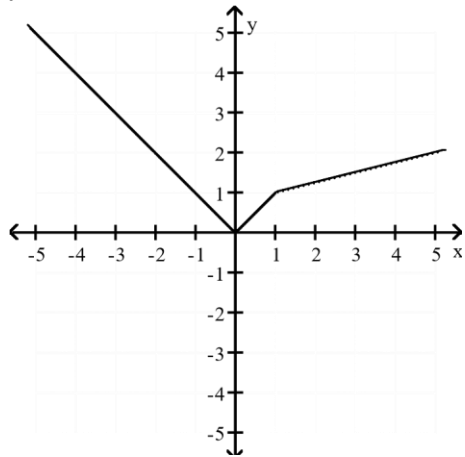

- A) 1.75
- B) 13
- C) -4
- D) 4

Answer: A

58) $y = f(x)$. Find $f(-4)$

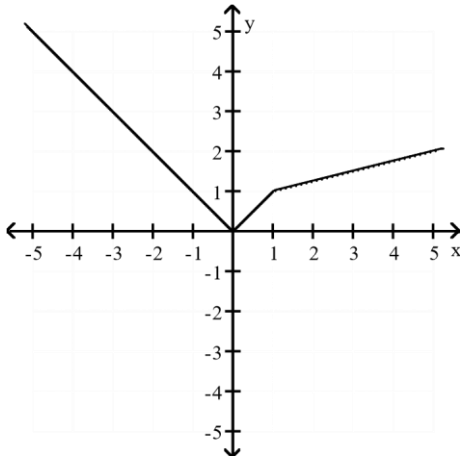

- A) 13
- B) 4
- C) -4
- D) 1.75

Answer: B

59) $y = f(x)$. Find $f(3)$

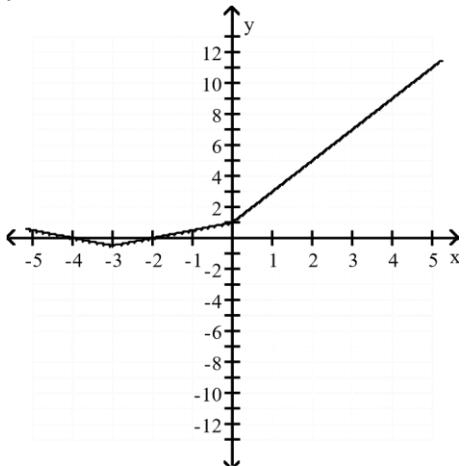

- A) -7
- B) 1
- C) 5
- D) 7

Answer: D

60) $y = f(x)$. Find $f(-4)$

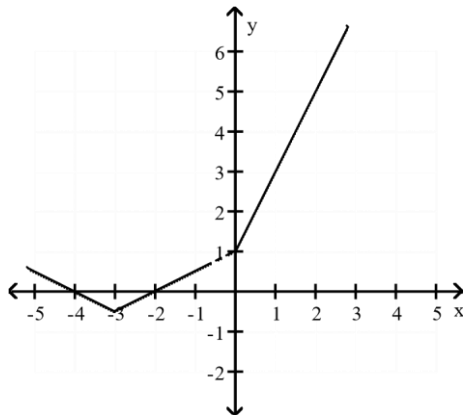

- A) 3
- B) 9
- C) 4
- D) 0

Answer: D

The graph below shows the percentage of students enrolled in the College of Engineering at State University. Use the graph to answer the question.

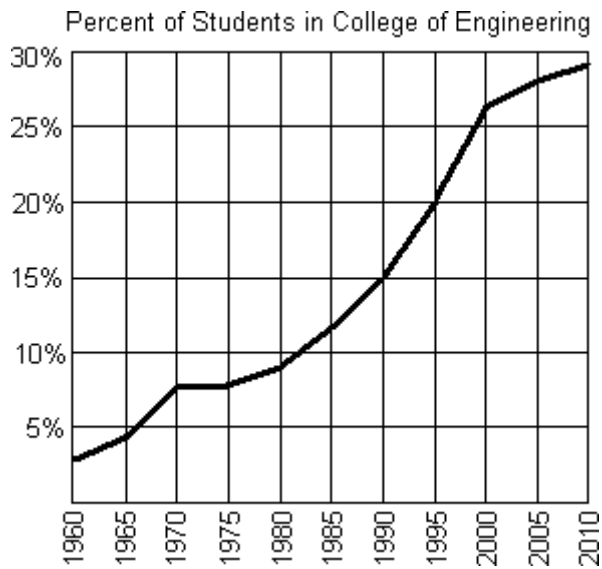

61) Does the graph represent a function?

- A) no
- B) yes

Answer: B

62) If f represents the function, find $f(2010)$.

- A) approximately 25.5%
- B) approximately 29%
- C) approximately 24%
- D) approximately 31%

Answer: B

63) If $f(x) = 20\%$, what year is represented by x ?

- A) 1985
- B) 2000
- C) 1995
- D) 1990

Answer: C

64) Between what two years is the difference in function values equal to 5%?

- A) between 1970 and 1975
- B) between 1980 and 1985
- C) between 1995 and 2000
- D) between 1990 and 1995

Use the graph to identify domain and range.

65)65)

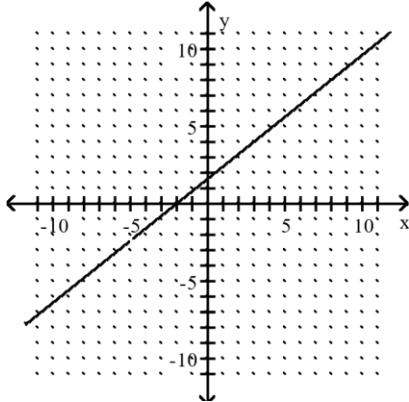

- A) domain: $(0, \infty)$
range: $(0, \infty)$
- B) domain: $(-\infty, \infty)$
range: $(-\infty, \infty)$
- C) domain: $(0, \infty)$
range: $(-\infty, \infty)$
- D) domain: $(-\infty, \infty)$
range: $(0, \infty)$

Answer: B

66)66)

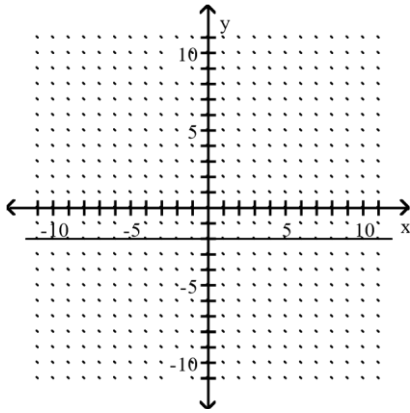

- A) domain: $\{-2\}$
range: $(0, \infty)$
- B) domain: $(0, \infty)$
range: $\{-2\}$
- C) domain: $(-\infty, \infty)$
range: $\{-2\}$
- D) domain: $\{-2\}$
range: $(-\infty, \infty)$

Answer: C

67)67)

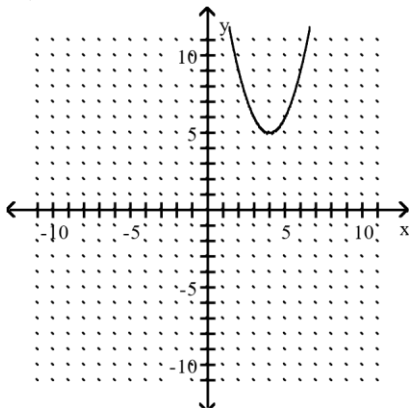

- A) domain: $(5, \infty)$
range: $(-\infty, \infty)$
- B) domain: $(-\infty, \infty)$
range: $[5, \infty)$
- C) domain: $[5, \infty)$
range: $(-\infty, \infty)$
- D) domain: $(-\infty, \infty)$
range: $(5, \infty)$

Answer: B

68)68)

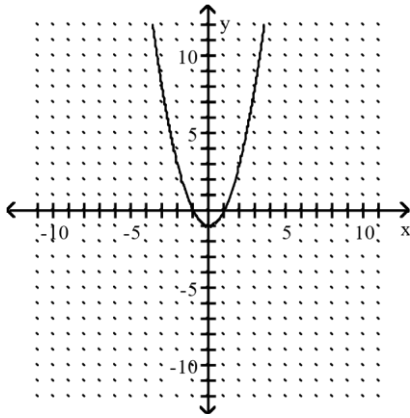

- A) domain: $(-\infty, \infty)$
range: $(-1, \infty)$
- B) domain: $(-1, \infty)$
range: $(-\infty, \infty)$
- C) domain: $(-\infty, \infty)$
range: $[-1, \infty)$
- D) domain: $[-1, \infty)$
range: $(-\infty, \infty)$

Answer: C

69)69)

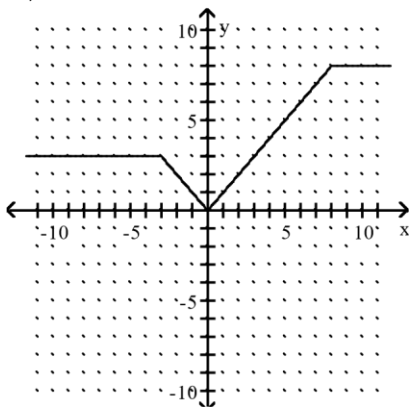

- A) domain: $[0, 8]$
range: $(-\infty, \infty)$
- B) domain: $(-\infty, \infty)$
range: $[3, 8]$
- C) domain: $[3, 8]$
range: $(-\infty, \infty)$
- D) domain: $(-\infty, \infty)$
range: $[0, 8]$

Answer: D

Find the domain of the function.

70) $f(x) = 7x + 5$

- A) $(-\infty, 0)$ or $(0, \infty)$
- B) $(-5, \infty)$
- C) $(-\infty, \infty)$
- D) $(-\infty, -5)$ or $(-5, \infty)$

Answer: C

$$= \frac{1}{x - 71} f(x) \quad \text{_____}$$

- A) $(-\infty, 9)$ or $(9, \infty)$
- B) $(9, \infty)$
- C) $(-\infty, \infty)$
- D) $(-\infty, 0)$ or $(0, \infty)$

Answer: A

72) $f(x) = \frac{1}{x - 5} f(x) + 3$

- A) $(-\infty, \infty)$
- B) $(-\infty, 0)$ or $(0, \infty)$
- C) $(-\infty, -3)$
- D) $(-\infty, -3)$ or $(-3, \infty)$

Answer: D

73) $f(x) = x - \frac{1}{x - 3} f(x) + 7$

$x - 3$

- A) $(-\infty, 3)$ or $(3, \infty)$ B) $(-\infty, \infty)$
- C) $(-\infty, 7)$ or $(7, \infty)$
- D) $(-\infty, 0)$ or $(0, \infty)$

Answer: A

$$= \frac{1}{x - 5} + \frac{4}{x + 10} f(x) \quad \text{_____} \quad \text{_____}$$

- A) $(-\infty, \infty)$
- B) $(-\infty, -5)$ or $(-5, 10)$ or $(10, \infty)$
- C) $(-\infty, -10)$ or $(5, \infty)$
- D) $(-\infty, -10)$ or $(-10, 5)$ or $(5, \infty)$

Answer: D

75) $f(x) = x^2 + 8$ A) $(-\infty, \infty)$

- B) $[-8, \infty)$
- C) $(-\infty, -8)$ or $(-8, \infty)$
- D) $(-8, \infty)$

Answer: A

76) $f(x) = \frac{\quad}{x^2 + 8}$

A) $(-\infty, \infty)$

B) $(-8, \infty)$

C) $(-\infty, -8)$ or $(-8, \infty)$ D) $(-\infty, 0)$ or $(0, \infty)$

Answer: A

Find the indicated function value.

77) $f(x) = 9 - 7x$, $g(x) = -3x + 7$

Find $(f + g)(x)$.

A) $6x$

B) $-10x + 16$

C) $-3x + 9$

D) $-4x + 16$ Answer: B

78) $f(x) = x + 2$, $g(x) = x + 7$ Find $(f + g)(1)$.

A) 11

B) -3

C) -7

D) 7

Answer: A

79) $f(x) = 4x + 5$, $g(x) = -4x + 3$ Find $(f + g)(-1)$.

A) 8

B) 4

C) 5

D) -6

Answer: A

80) $f(x) = 5x^2 + 7x + 6$, $g(x) = 3x + 4$

Find $(f + g)(5)$.

A) -65

B) 185

C) 245

D) 261

Answer: B

81) $f(x) = 3x - 1$, $g(x) = 2x^2 - 1$ Find $(f + g)(3)$.

A) 27

B) 19

C) 26

D) 25

Answer: D

$$f(x) =$$

82) $2x - 5, g(x) = 2x^2 + 2x - 1$

Find $(f + g)(4)$.

A) 26

B) 34

C) 42

D) 36

Answer: C

83) $f(x) = 4x^2 - 4, g(x) = 2x^2 - 2$ Find $(f + g)(5)$.

A) 144

B) 104

C) 48

D) 148

Answer: A

84) $f(x) = 2x^2 - 2, g(x) = 3x^2 + 3x - 3$ Find $(f + g)(4)$.

A) 93

B) 87

C) 51

D) 63

Answer: B

85) $f(x) = x^2 + \frac{1}{3}x - 3, g(x) = x^3 - \frac{2}{3}x^2 + x$

Find $(f + g)(x)$.

A) $x^3 + \frac{1}{3}x^2 + \frac{4}{3}x - 3$

B) $2x^3 - \frac{1}{6}x^2 - 2x$

C) $2x^3 - \frac{1}{3}x^2 - 2x$

3

D) $x^3 + \frac{1}{6}x^2 + \frac{2}{3}x - 3$

Answer: A

$$f(x) =$$

For the pair of functions, determine the domain of $f + g$.

86) $f(x) = 2x + 7, g(x) = 2x + 6$

A) $(-\infty, \infty)(-\infty, \infty)$

B) $(-\infty, -2)$ or $(-2, \infty)$ C) $(-\infty, 0)$ or $(0, \infty)$

D) $(0, \infty)$

Answer: A

87) $5x - 1, g(x) = \frac{\quad}{x - 2}^4$

A) $(0, \infty)$

B) $(-\infty, -4)$ or $(-4, \infty)$

C) $(-\infty, \infty)$

D) $(-\infty, 2)$ or $(2, \infty)$

Answer: D

88) $f(x) = 5x + 5, g(x) = \frac{\quad}{x + 1}^3$

A) $(0, \infty)$

B) $(-\infty, -1)$ or $(-1, \infty)$

C) $(-\infty, -3)$ or $(-3, \infty)$

D) $(-\infty, \infty)$ Answer: B

89) $f(x) = \frac{2x}{x - 1}, g(x) = \frac{4}{x + 9}$

A) $(-\infty, -1)$ or $(-1, 9)$ or $(9, \infty)$

B) $(-\infty, \infty)$

C) $(-\infty, -9)$ or $(-9, 1)$ or $(1, \infty)$

D) $(-\infty, -9)$ or $(1, \infty)$

Answer: C

90) $f(x) = 3x^2 + 1, g(x) = 5x^3 - 7$

A) $(-$

$\infty,$

$0)$

B)

$(-$

$\infty,$

$\infty)$

C) $(-\infty, 0)$ or $(0, \infty)$

$$f(x) =$$

$$D) (0, \infty)$$

Answer: B

Find the requested value.

$$91) f(x) = -5x^2 - 5x + 8, g(x) = 3x - 8 \text{ Find}$$

$$f(-2) + g(-2).$$

$$A) 24$$

$$B) -16$$

$$C)$$

$$2$$

$$D) 26$$

Answer: B

$$92) f(x) = -3x^2 - 4, g(x) = x - 1 \text{ Find } f(-4) -$$

$$g(-4). A) -55$$

$$B) -47$$

$$C) -49$$

$$D) 56$$

Answer: B

$$93) -4x - 1, g(x) = 4x^2 - 5x + 5 \text{ Find } \left(\frac{f}{g} \right) (2).$$

$$A) -\frac{7}{11}$$

$$B) -9$$

$$C) -\frac{9}{11}$$

$$D) \frac{9}{11}$$

Answer: C

$$94) f(x) = x - 2, g(x) = x - 6$$

$$\text{Find } (f + g)(2).$$

$$A) 0 \text{ B) } 12$$

$$C) -4$$

$$D) 8$$

Answer: C

$$95) f(x) = 5x^2 - 4, g(x) = x - 7 \text{ Find } (f - g)(4).$$

$$A) 87$$

$$B) 79$$

$$f(x) =$$

C) 65

D) -80

Answer: B

96) $f(x) = x - 1$, $g(x) = 4x^2 + 13x + 1$ Find $(fg)(-3)$.

A) 8

B) 4

C) 116

D) -74

Answer: A

97) $f(x) = 3x - 4$, $g(x) = 5x^2 + 14x + 2$ Find $f \circ g(-3)$.

A) $\frac{1}{5}$

B) $\frac{5}{-5}$

C) $-\frac{13}{5}$

D) 3

Answer: C

Use the graph to find the value.

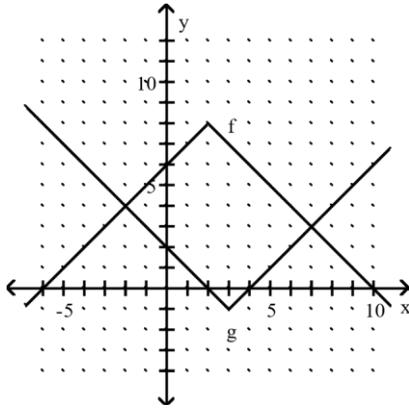

98) $(f + g)(5)$

- A) -12
- B) -4
- C) 4
- D) 6

Answer: D

99) $(f - g)(-5)$

- A) -8
- B) 8
- C) -6
- D) 6

Answer: C

100) $(fg)(7)$

- A) 6
- B) -9
- C) 9
- D) -6

Answer: C

101) $\left(\frac{f}{g}\right)(6)$

- A) $\frac{1}{2}$
- B) $-\frac{1}{2}$

- C) 2
- D) - 2

Answer: C

Solve the problem.

102) A firm making toaster ovens finds that the total cost, $C(x)$, of producing x units is given by $C(x) = 25x + 340$. The revenue, $R(x)$, from selling x units is determined by the price per unit times the number of units sold, thus $R(x) = 35x$.

Find and interpret $(R - C)(78)$.

- A) \$112 profit, income exceeds cost
- B) \$5020 profit, income exceeds cost
- C) -\$440 loss, cost exceeds income
- D) \$440 profit, income exceeds cost

Answer: D

103) A firm making microwave ovens finds that the total cost, $C(x)$, of producing x units is given by $C(x) = 55x + 600$.

The revenue, $R(x)$, from selling x units is determined by the price per unit times the number of units sold, thus $R(x) = 65x$.

Find and interpret $(R - C)(42)$.

- A) \$180 profit, income exceeds cost
- B) \$102 profit, income exceeds cost
- C) \$5640 profit, income exceeds cost D) -\$180 loss, cost exceeds income

Answer: D

104) A firm is considering a new product. The accounting department estimates that the total cost, $C(x)$, of producing x units will be

$$C(x) = 50x + 9010.$$

The sales department estimates that the revenue, $R(x)$, from selling x units will be

$R(x) = 60x$, but that no more than 488 units can be sold at that price. Find and interpret $(R - C)(488)$. A) \$4130 profit, income exceeds cost It is worth it to develop product.

- B) \$62,690 profit, income exceeds cost It is worth it to develop product.
- C) -\$4130 loss, cost exceeds income It's not worth it to develop product.

D) \$1389 profit, income exceeds cost
It is worth it to develop product.

Answer: C

105) A firm is considering a new product. The accounting department estimates that the total cost, $C(x)$, of producing x units will be

$$C(x) = 95x + 3720.$$

The sales department estimates that the revenue, $R(x)$, from selling x units will be

$R(x) = 105x$, but that no more than 987 units can be sold at that price. Find and interpret $(R - C)(987)$.

A) -\$6150 loss, cost exceeds income

It is not worth it to develop product.

B) \$201,120 profit, income exceeds cost
It is worth it to develop product.

C) \$1359 profit, income exceeds cost
It is worth it to develop product.

D) \$6150 profit, income exceeds cost
It is worth it to develop product.

Answer: D

106) The function $f(t) = -0.14t^2 + 0.49t + 31.3$ models a certain country's population in millions, ages 65 and older, where t represents years after 2010. The function $g(t) = 0.54t^2 + 11.84t + 108.1$ models the total yearly cost of the government's health insurance program in billions of dollars, where t represents years after 2010. What does the

$\frac{g \text{ function}}{f}$ represent? Find $\left(\frac{g}{f}\right)(5)$.

A) Cost per person in thousands of dollars. \$12.22 thousand

B) Cost per person in thousands of dollars. \$5.98 thousand

C) Cost per person in thousands of dollars. \$0.17 thousand

D) Cost per person in thousands of dollars. \$0.21 thousand
Answer: B

Use intercepts and a checkpoint to graph the linear function.

107) $x + 4y = 8$

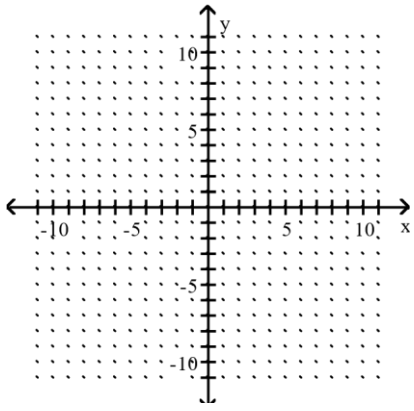

A) $(0, 2), (-2, 0)$

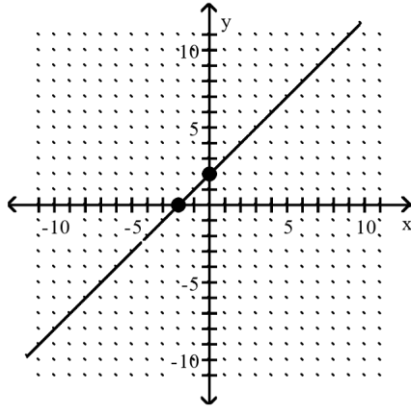

B) $(0, -8), (8, 0)$

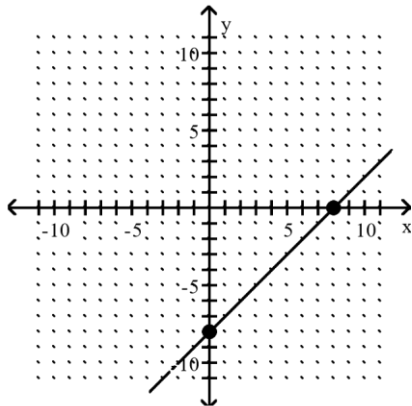

C) $(0, 2), (-8, 0)$

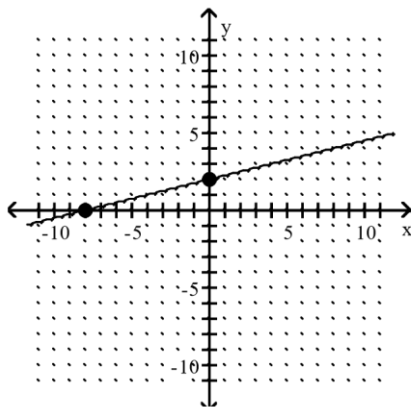

D) $(0, 2), (8, 0)$

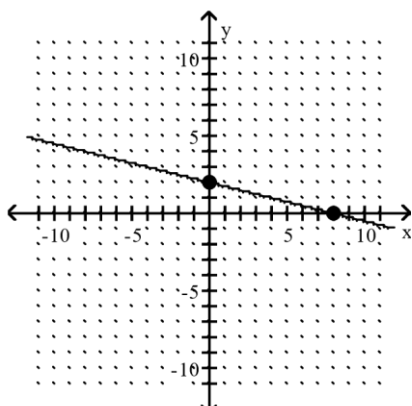

108) $2x - 4y = 6$

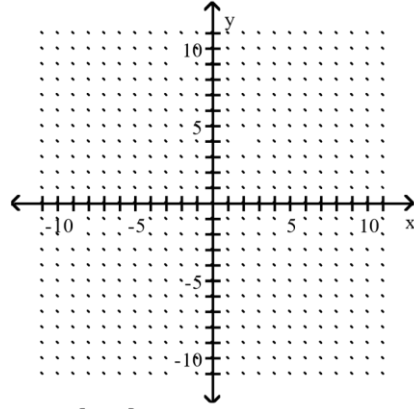

A) $\left(0, \frac{3}{2}\right), (-3, 0)$

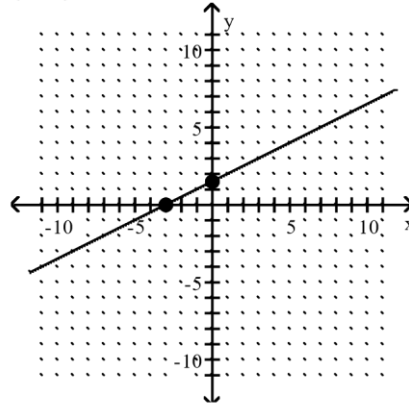

B) $\left(0, -\frac{3}{2}\right), (-3, 0)$

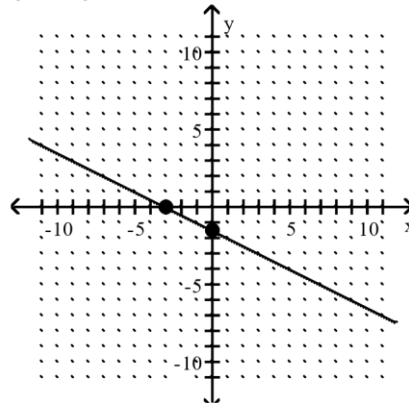

C) $\left(0, -\frac{3}{2}\right), (3, 0)$

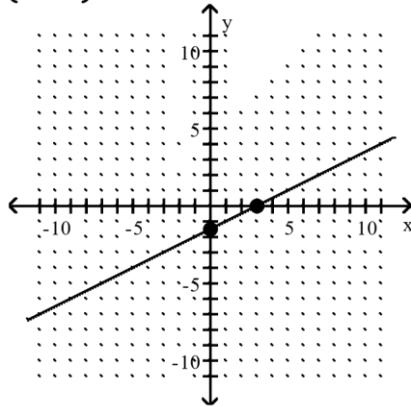

D) $(0, 3), \left(-\frac{3}{2}, 0\right)$

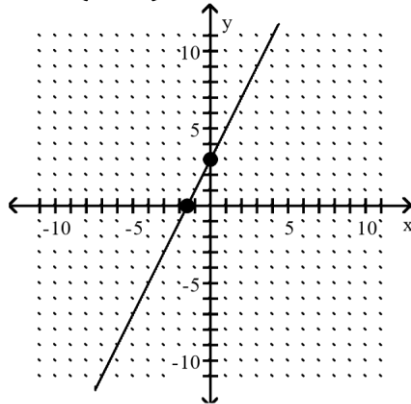

Answer: C

109) $x - 3y = -6$

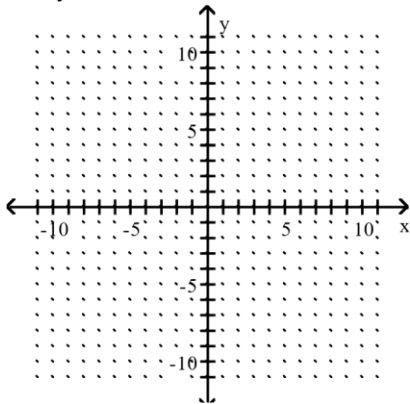

A) $(0, 2), (6, 0)$

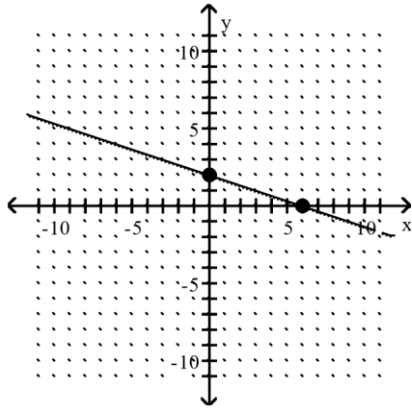

B) $(0, 2), (-6, 0)$

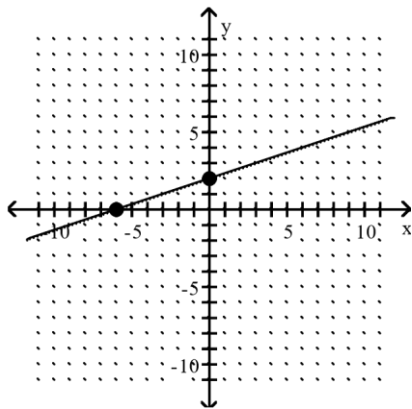

C) $(0, -6), (6, 0)$

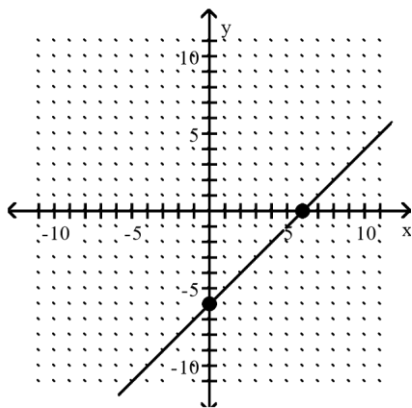

D) $(0, 2), (-2, 0)$

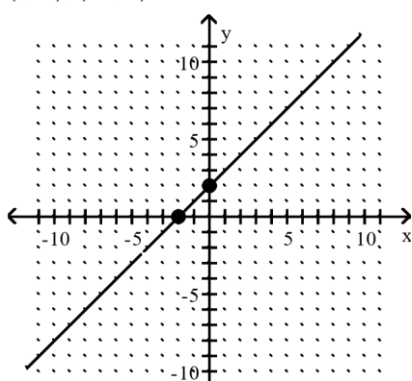

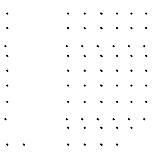

110) $2x - 10y = 10$

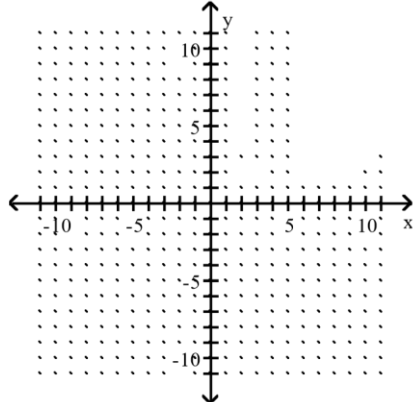

A) $(0, -1), (5, 0)$

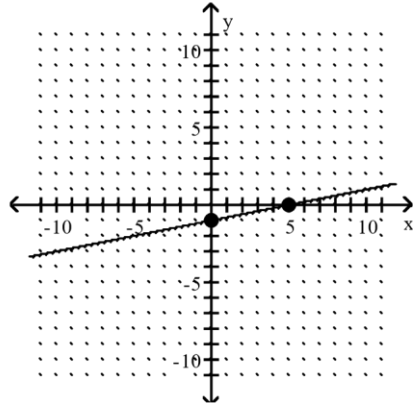

B) $(0, -5), (1, 0)$

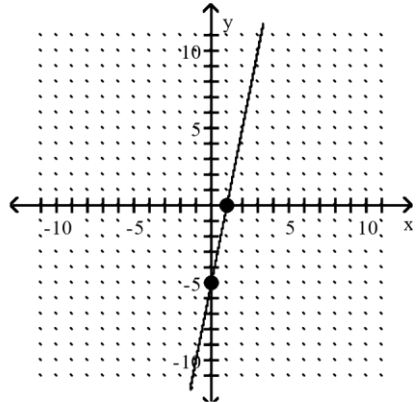

C) $(0, 5), (-1, 0)$

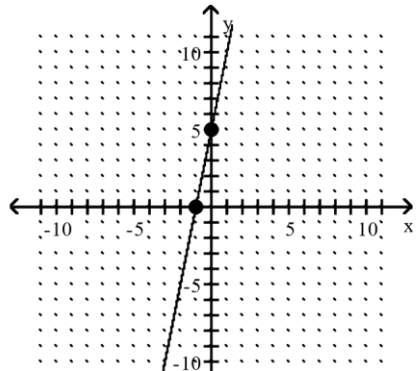

D) (0, -1), (-5, 0)

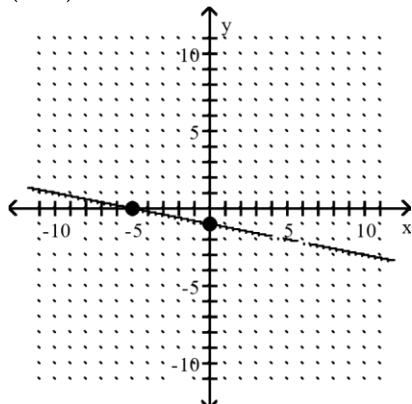

Answer: A

111) $-4x - 24y = 24$

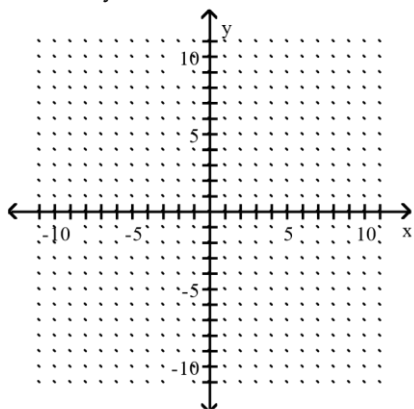

A) (0, -1), (-6, 0)

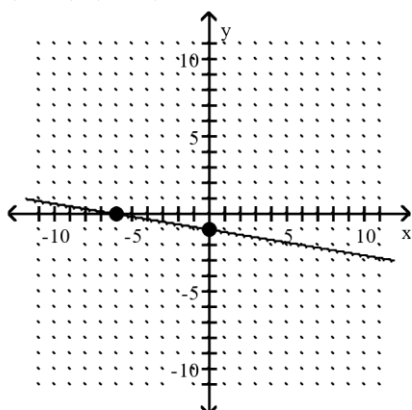

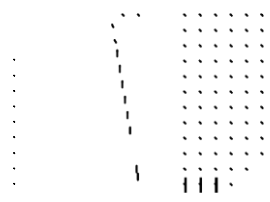

B) $(0, -6), (-1, 0)$

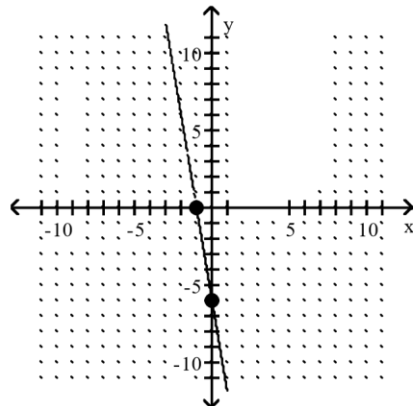

C) $(0, -1), (6, 0)$

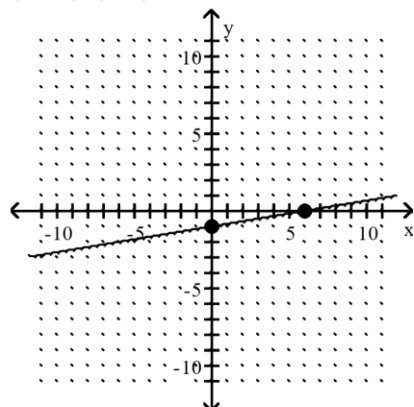

D) $(0, 6), (1, 0)$

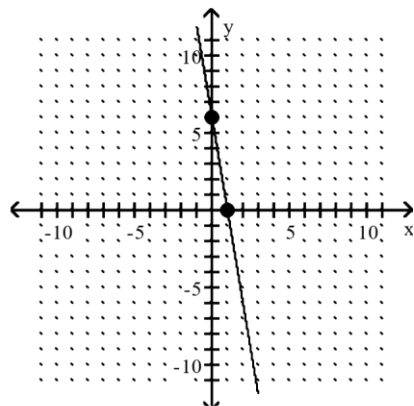

Answer: A

$$\frac{1}{2}$$

⋮ ⋮ ⋮⋮⋮⋮⋮
⋮ ⋮ ⋮⋮⋮⋮⋮
⋮ ⋮ ⋮⋮⋮⋮⋮
⋮ ⋮ ⋮⋮⋮⋮⋮
⋮ ⋮ ⋮⋮⋮⋮⋮
⋮ ⋮ ⋮⋮⋮⋮⋮

112) $y - x = 2$

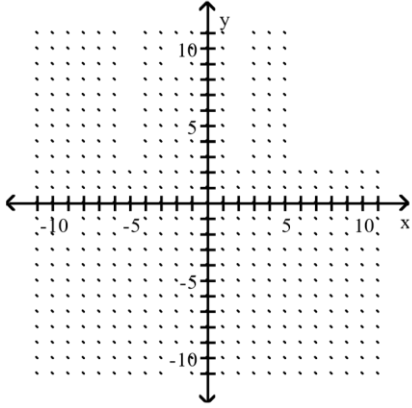

A) $(0, 2), (-2, 0)$

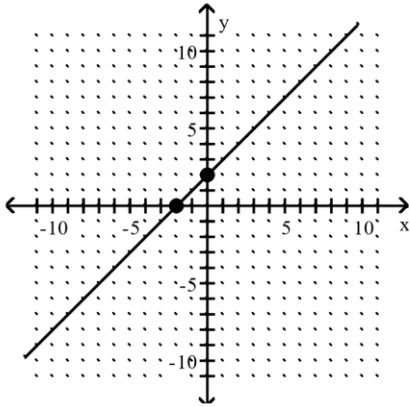

B) $(0, 2), (4, 0)$

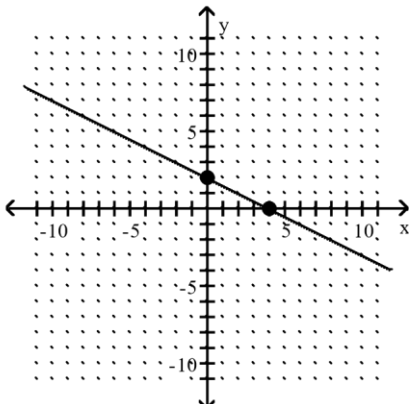

C) $(0, 2), (-4, 0)$

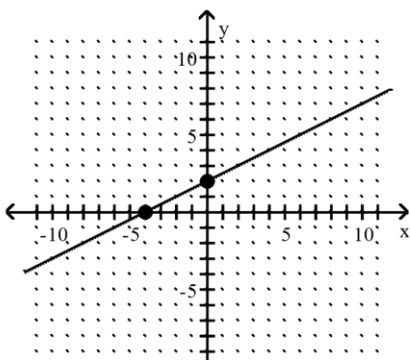

D) (0, -4),
0)

(4,

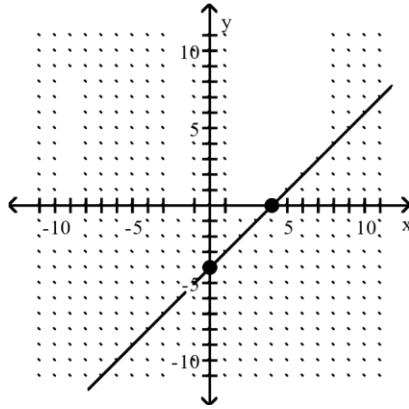

Answer: C

$$\frac{1}{3}y + x = 2$$

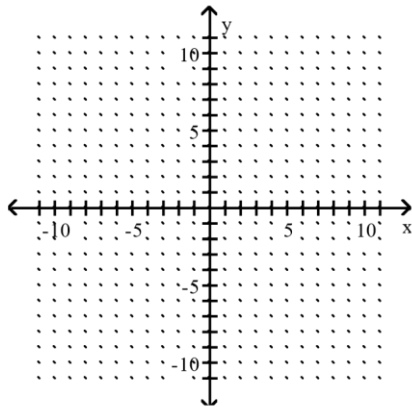

A) (0, 2), (-2, 0)

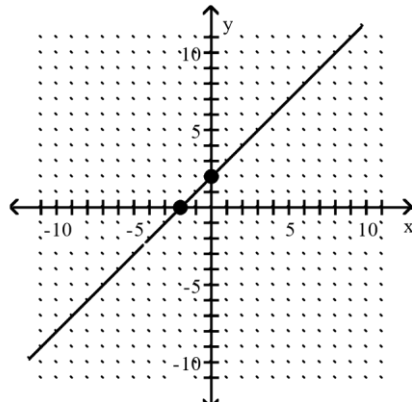

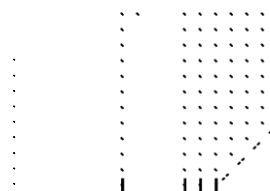

B) $(0, -6), (6, 0)$

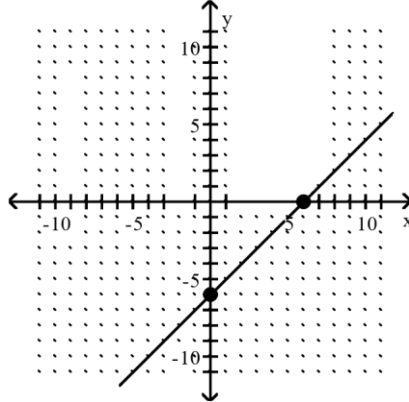

C) $(0, 2), (-6, 0)$

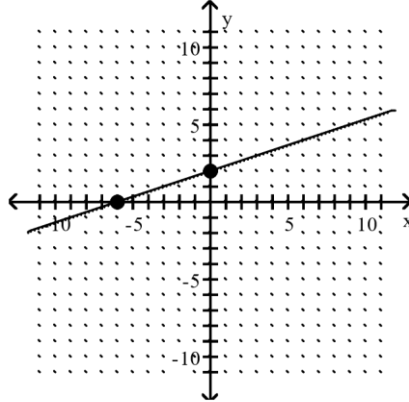

D) $(0, 2), (6, 0)$

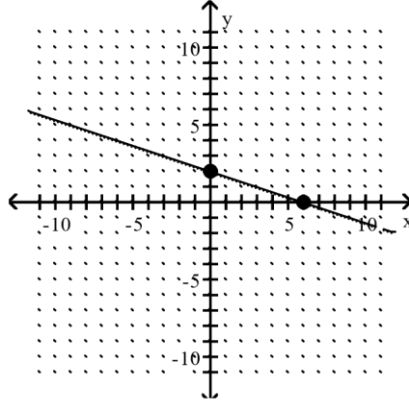

Answer: D

114) $-2x - 4y = 4$

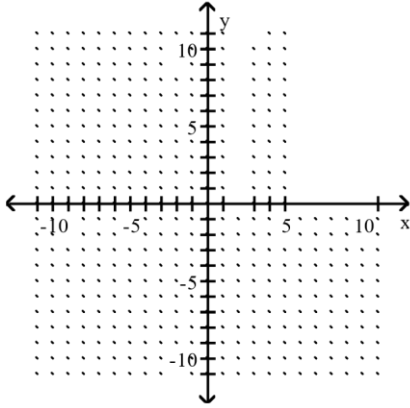

A) $(0, 2), (1, 0)$

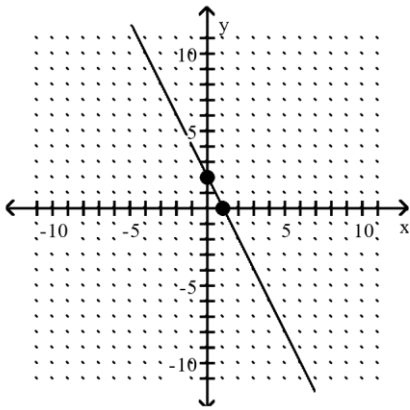

B) $(0, -1), (2, 0)$

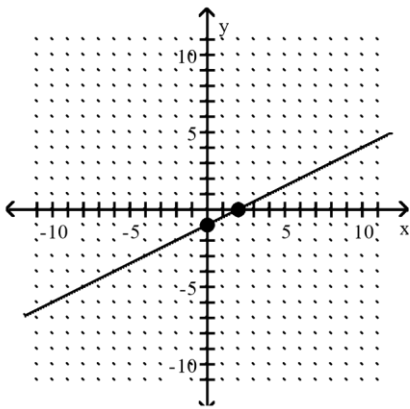

C) $(0, -1), (-2, 0)$

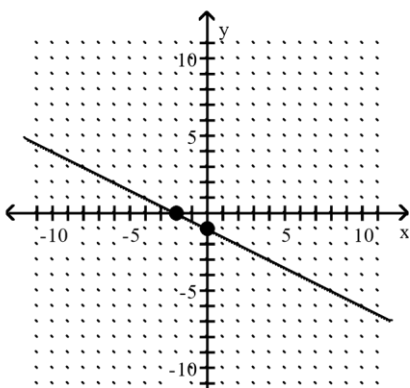

D) $(0, -2), (-1, 0)$

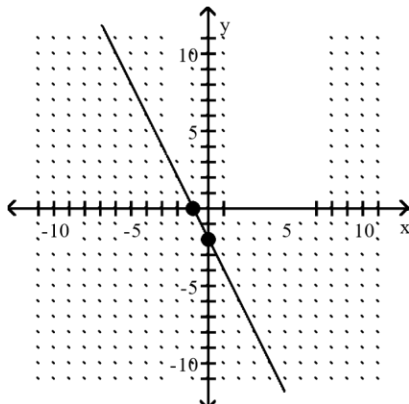
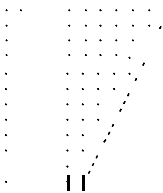

Answer: C

115) $5x - 10y = 30$

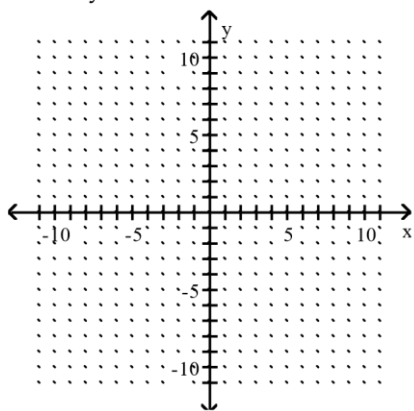

A) $(0, 6), (-3, 0)$

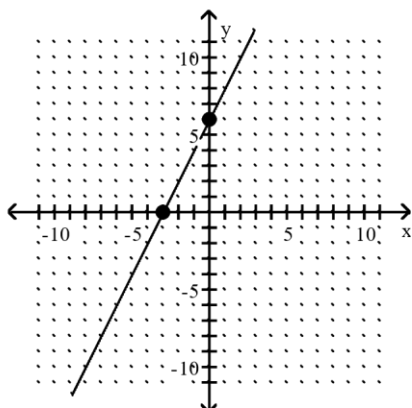

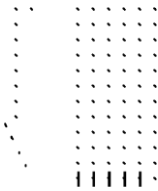

B) $(0, -6), (3, 0)$

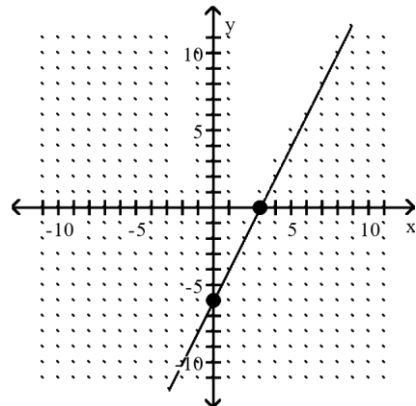

C) $(0, -3), (6, 0)$

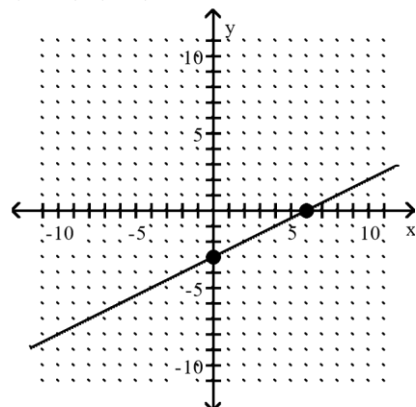

D) $(0, -3), (-6, 0)$

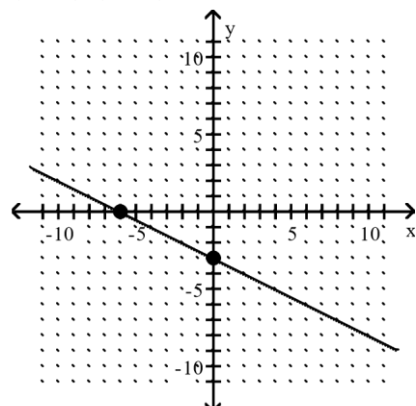

Answer: C

116) $50x + 40y = 200$

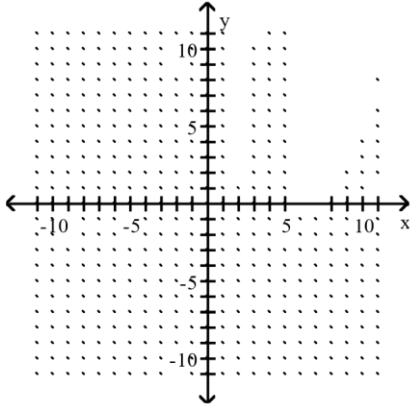

A) $(0, 5), (-4, 0)$

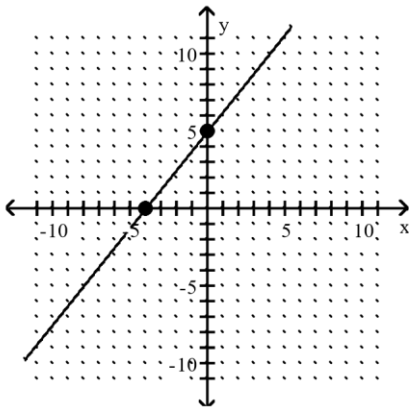

B) $(0, -5), (4, 0)$

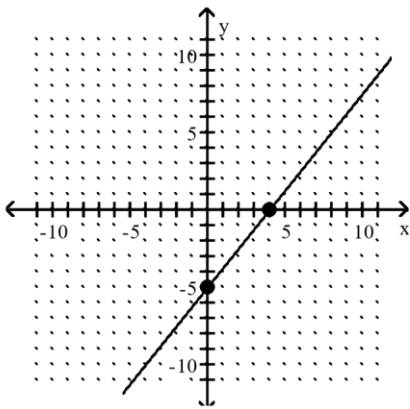

C) $(0, -5), (-4, 0)$

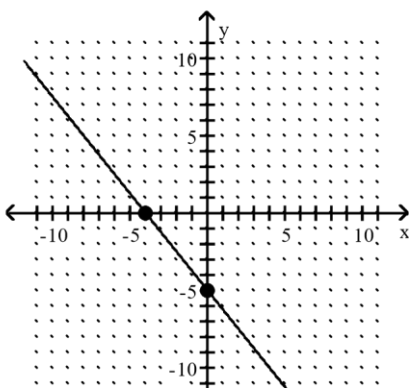

D) (0, 5), (4, 0)

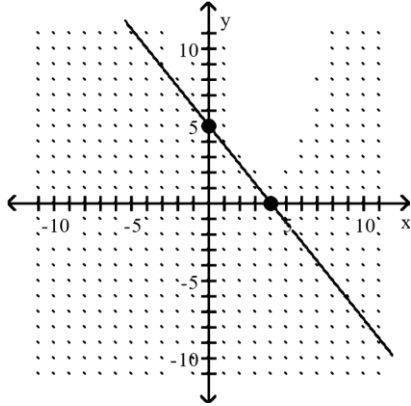

Answer: D

Find the slope of the line that goes through the given points.

117) (4, -3), (-5, -1)

A) $\frac{2}{9}$

B) $-\frac{9}{2}$

C) 4

D) $-\frac{2}{9}$

Answer: D

118) (-8, -9), (-8, 5)

A) $\frac{1}{4}$

B) $\frac{7}{8}$

C) 0

D) Undefined

Answer: D

119) (4, 1), (-6, 1)

A) 0

B) -1

C) Undefined D) $-\frac{1}{5}$ Answer: A

120) (-8, 19), (-7, 7)

A) $-\frac{26}{15}$

B) -12

C) $-\frac{1}{12}$

D) 12

Answer: B

121) (-1, -8), (9, -3)

A) $\frac{12}{7}$

B) $\frac{7}{12}$

C) $\frac{1}{2}$

D) 2

Answer: C

122) (1, 2), (-5, 2)

A) 5

B) 11

C) 0

D) 1

Answer: C

123) (-2, -5) and $(\frac{3}{4}, 5)$

A) $\frac{40}{11}$

B) $\frac{11}{40}$

C) $-\frac{11}{40}$

D) 0

Answer: A

124) $(\frac{3}{4}, 5)$ and $(\frac{3}{4}, -1)$

A) $\frac{16}{3}$

B) $-\frac{1}{8}$

C) Undefined

D) -8

Answer: C

Find the slope of the line.

125)

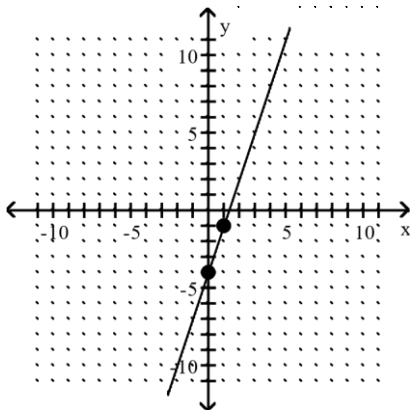

- A) -3
- B) 3
- C) $-\frac{1}{3}$
- D) $\frac{1}{3}$

Answer: B

126)

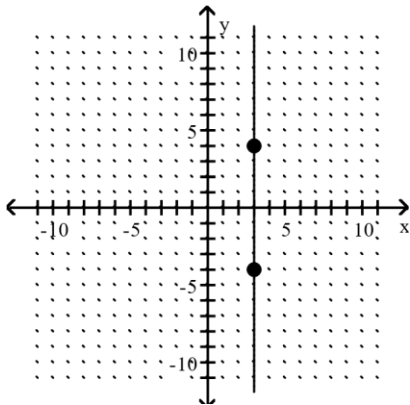

- A) 3
- B) 0
- C) 4
- D) undefined

Answer: D

127)

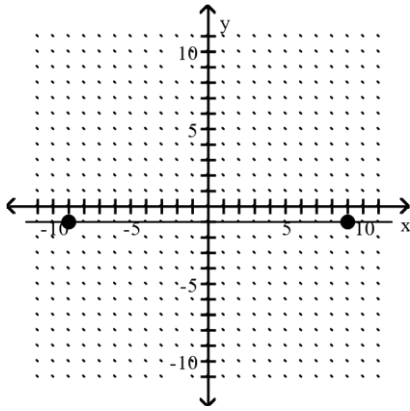

- A) -1
- B) -9
- C) 0
- D) undefined Answer: C

Solve for k if the line through the two given points is to have the given slope.

129) $(5, 5)$ and $(8, k)$, $m = -\frac{2}{3}$

- A) $k = -3$
- B) $k = 3$
- C) $k = \frac{1}{2}$
- D) $k = -\frac{1}{2}$

Answer: B

Rewrite the given equation in slope-intercept form by solving for y.

130) $x + y = -7$

- A) $y = x - 7$
- B) $y = x + 7$
- C) $y = -x + 7$
- D) $y = -x - 7$

Answer: D

131) $6x + y = 4$

- A) $y = -6x + 4$ B) $y = 6x + 4$
- C) $y = -\frac{1}{6}x + \frac{2}{3}$
- D) $y = \frac{3}{2}x + \frac{1}{4}$

Answer: A

132) $12x - 8y = 96$

A) $y = -\frac{3}{2}x + 12$

B) $y = \frac{3}{2}x - 12$

C) $y = 12x + 96$

D) $y = \frac{2}{3}x + 8$

Answer: B

133) $-x + 11y = 132$

A) $y = -x + 132$ B) $y = 11x - 132$

C) $y = \frac{1}{11}x + 12$

D) $y = -\frac{1}{11}x + 12$

Answer: C

Find the slope and the y-intercept of the line.

134) $y = \frac{7}{8}x + 8$

A) $m = \frac{7}{8}; b = 8$

B) $m = 8; b = \frac{7}{8}$

C) $m = -\frac{7}{8}; b = -8$

D) $m = \frac{8}{7}; b = -8$

Answer: A

135) $y = 5x$

A) $m = \frac{1}{5}; b = 0$

B) $m = -5; b = 0$ C) $m = 0; b = 5$

D) $m = 5; b = 0$

Answer: D

136) $f(x) = 3x$

A) $m = \frac{1}{3}; b = 0$

B) $m = -3; b = 0$ C) $m = 0; b = 3$

D) $m = 3; b = 0$

Answer: D

136) $f(x) = \frac{1}{5}x$

A) $m = -\frac{1}{5}; b = 0$

B) $m = \frac{1}{5}; b = 0$

C) $m = 0; b = \frac{1}{5}$

D) $m = 5; b = 0$

Answer: B

137) $2x + 5y = -26$

A) $m = \frac{5}{2}; b = \frac{26}{5}$ B) $m = -\frac{2}{5}; b = \frac{26}{5}$

C) $m = -\frac{2}{5}; b = -\frac{26}{5}$

D) $m = \frac{2}{5}; b = -\frac{26}{5}$

Answer: C

138) $3y = 4x - 39$

A) $m = \frac{4}{3}; b = 13$ B) $m = -\frac{3}{4}; b = 13$

C) $m = \frac{4}{3}; b = -13$

D) $m = -\frac{4}{3}; b = -13$

Answer: C

139) $4y - 5x = 28$

A) $m = \frac{5}{4}; b = -7$

B) $m = -\frac{5}{4}; b = 7$

C) $m = -\frac{4}{5}; b = -7$

D) $m = \frac{5}{4}; b = 7$

Answer: D

140) $-2y + 4x = 8$

A) $m = -2; b = -4$

B) $m = 2; b = -4$

C) $m = -\frac{1}{2}$; $b = 4$

D) $m = 2$; $b = 4$

Answer: B

141) $x = 5y + 7$

A) $m = 5$; $b = -\frac{7}{5}$

B) $m = 5$; $b = 7$

C) $m = \frac{1}{5}$; $b = -\frac{7}{5}$ D) $m = -\frac{1}{5}$; $b = -\frac{7}{5}$

Answer: C

142) $x + y - 12 = 0$

A) $m = 1$; $b = 12$

B) $m = -1$; $b = -12$ C) $m = 0$; $b = 12$

D) $m = -1$; $b = 12$

Answer: D

143) $3x + y + 4 = 0$

A) $m = -\frac{1}{3}$; $b = -\frac{4}{3}$

B) $m = -3$; $b = -4$ C) $m = 3$; $b = -4$

D) $m = -\frac{3}{4}$; $b = -\frac{1}{4}$

Answer: B

144) $x + 14y - 1 = 0$

A) $m = -\frac{1}{14}$; $b = \frac{1}{14}$

B) $m = -14$; $b = 14$

C) $m = \frac{1}{14}$; $b = \frac{1}{14}$

D) $m = 1$; $b = 1$

Answer: A

145) $-x + 2y - 18 = 0$

A) $m = 2$; $b = -18$

B) $m = -1$; $b = 18$

C) $m = \frac{1}{2}$; $b = 9$

D) $m = -\frac{1}{2}$; $b = 9$

Answer: C

146) $5x - 2y - 10 = 0$

A) $m = \frac{2}{5}; b = 2$

B) $m = -\frac{5}{2}; b = 5$

C) $m = 5; b = 10$

D) $m = \frac{5}{2}; b = -5$

Answer: D

Use the slope and y-intercept to graph the linear function.

147) $y = -6x$

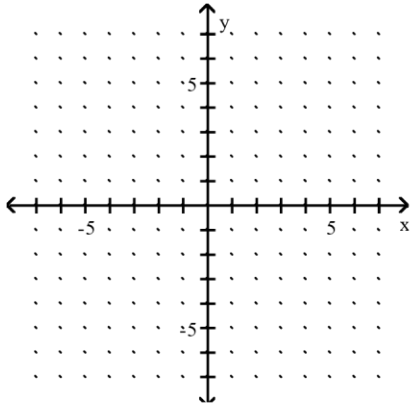

A)

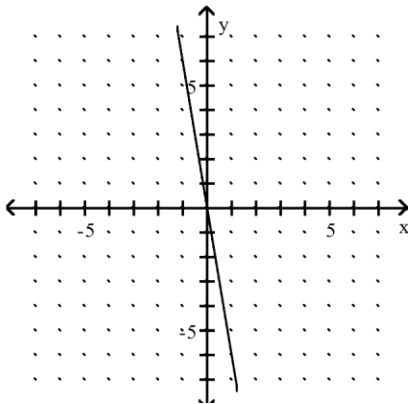

B)

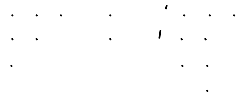

| | | | |

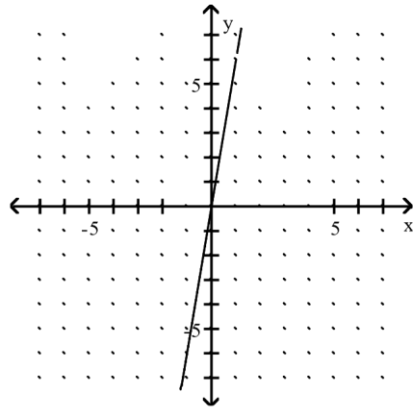

C)

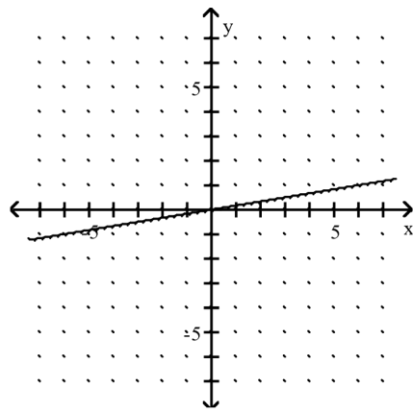

D)

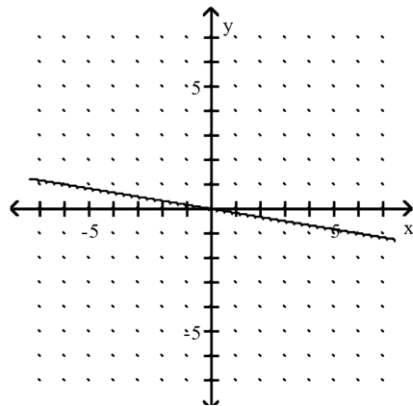

Answer: A

$$\frac{1}{3}$$

148) $f(x) = -\frac{1}{3}x$

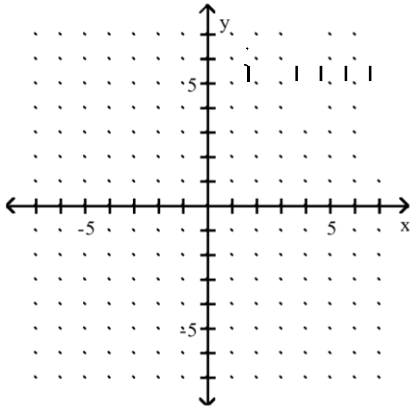

A)

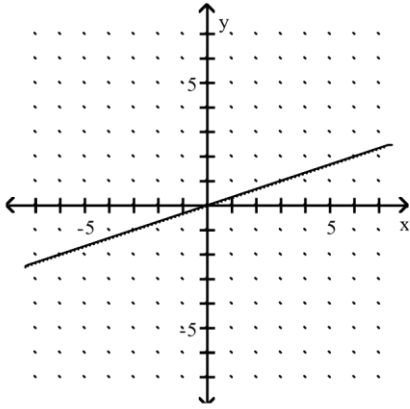

B)

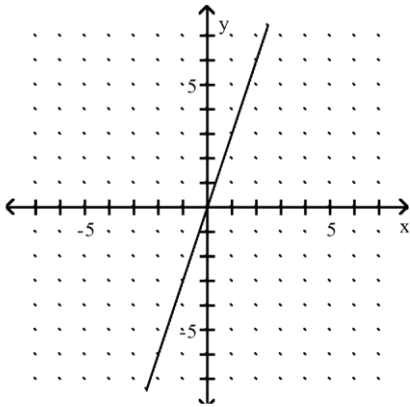

C)

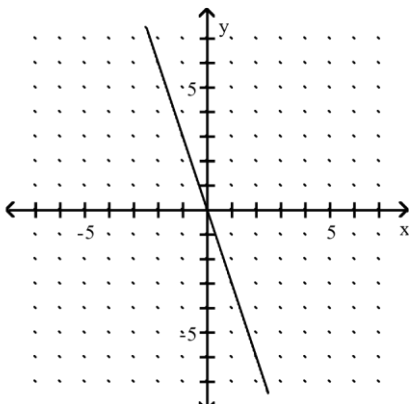

D)

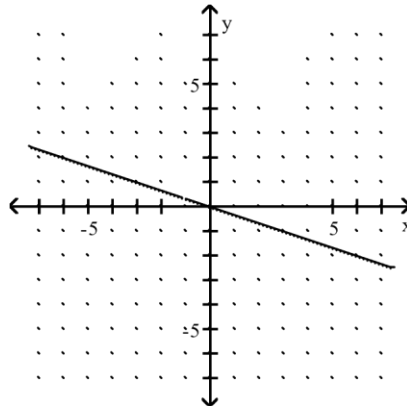

Answer: D

149) $8x + 7y = 0$

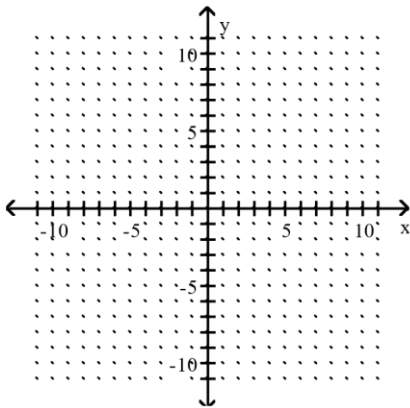

A)

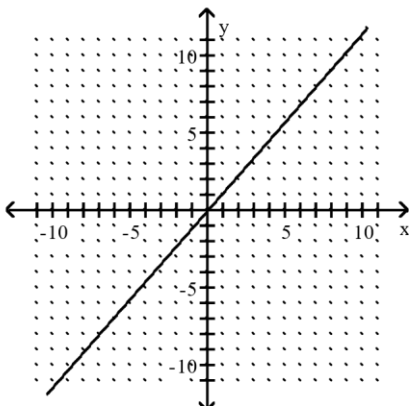

B)

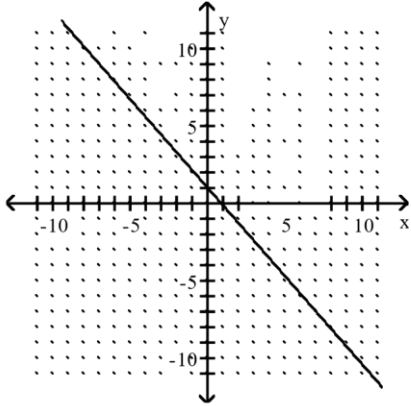
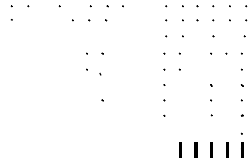

C)

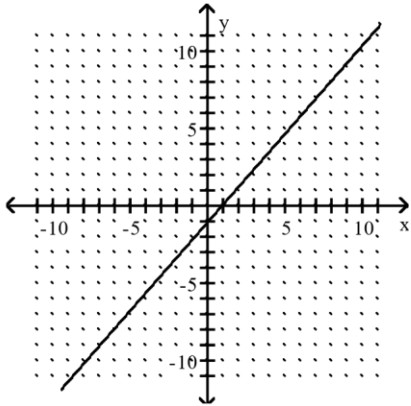

D)

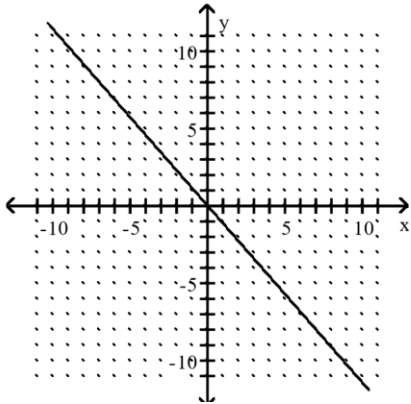

Answer: D

150) $9x - 5y = 0$

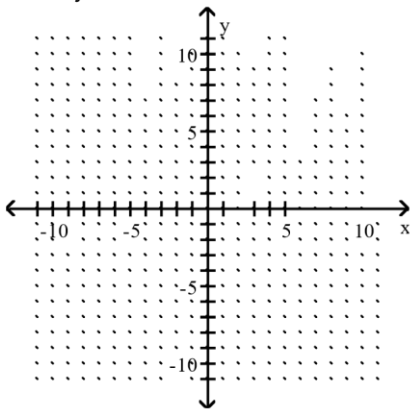

A)

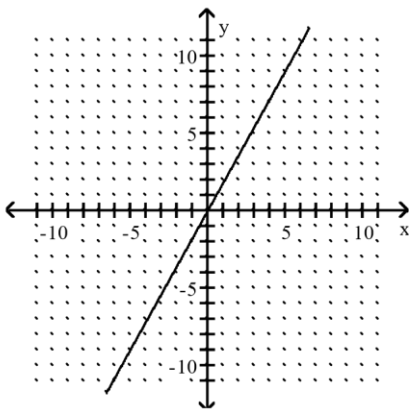

B)

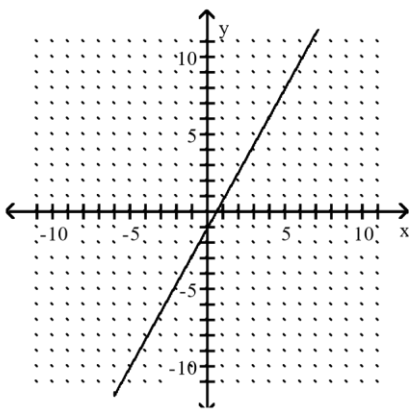

C)

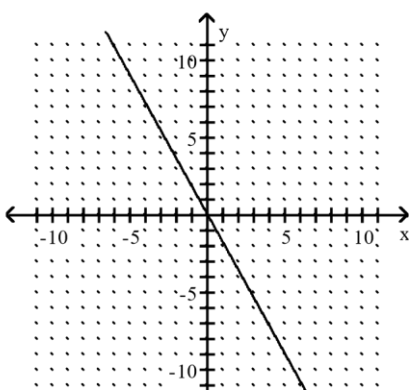

D)

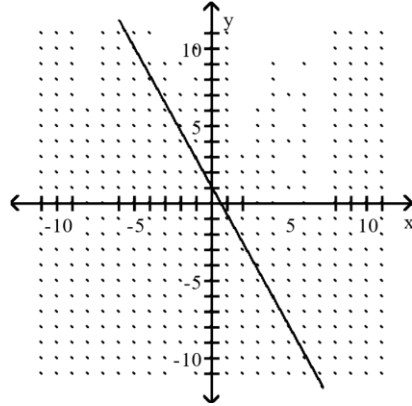
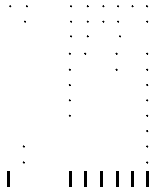

Answer: A

151) $-2x + 7y = 0$

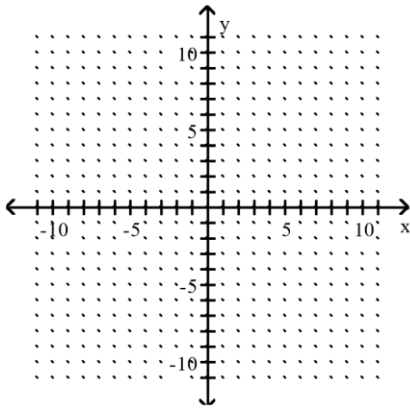

A)

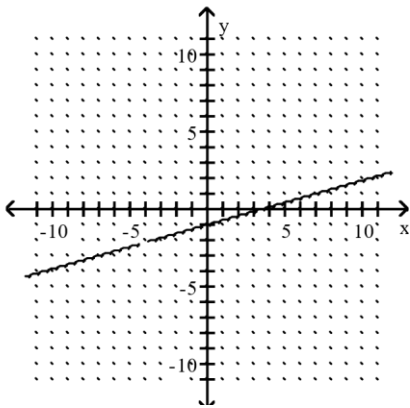

B)

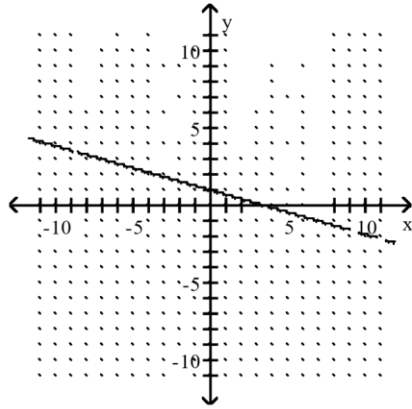
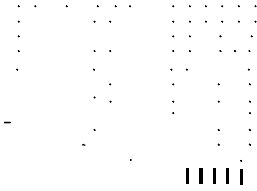

C)

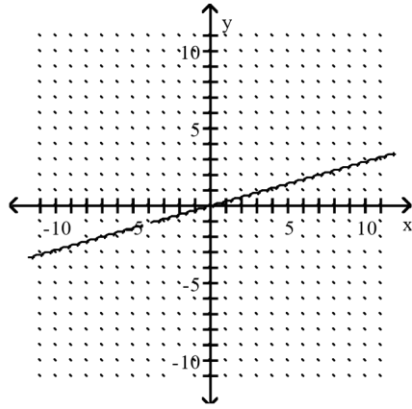

D)

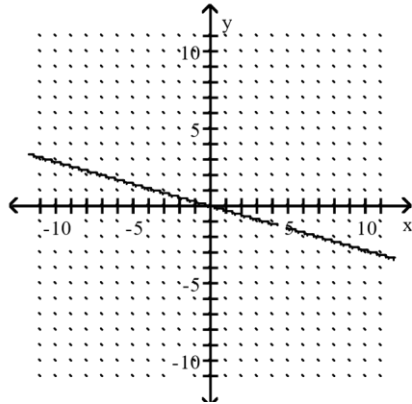

Answer: C

152) $f(x) = 2x + 2$

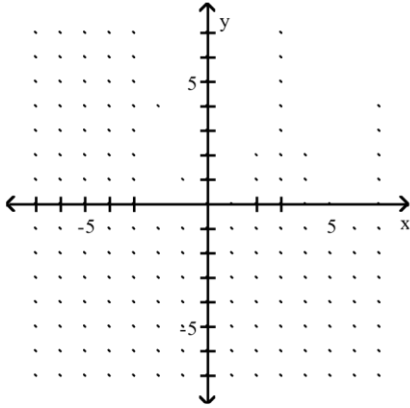

A)

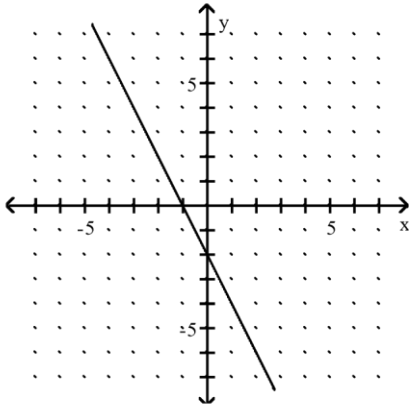

B)

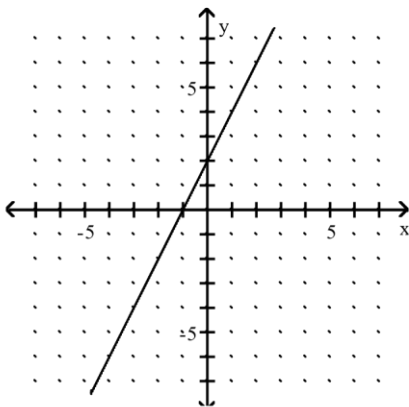

C)

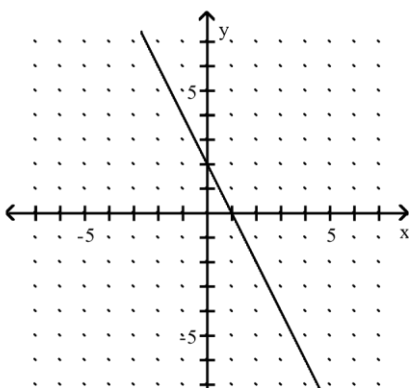

D)

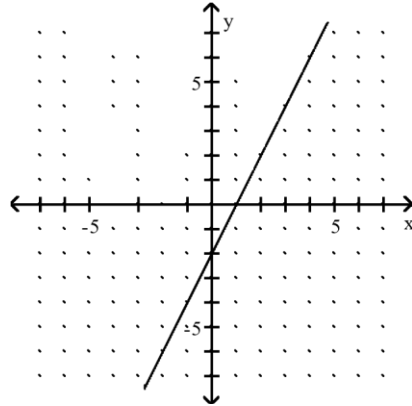
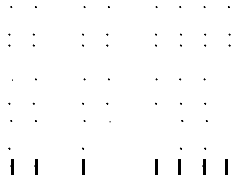

Answer: B

153) $g(x) = -3x + 2$

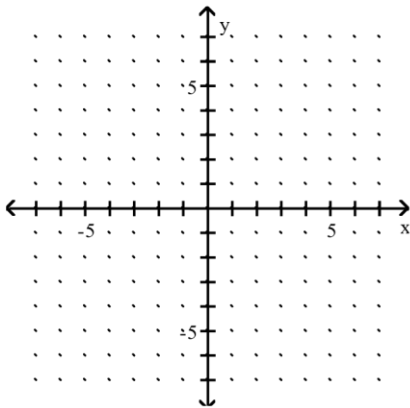

A)

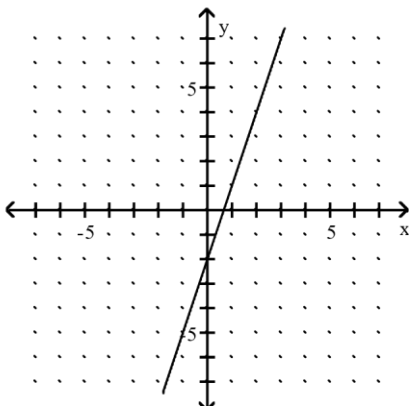

B)

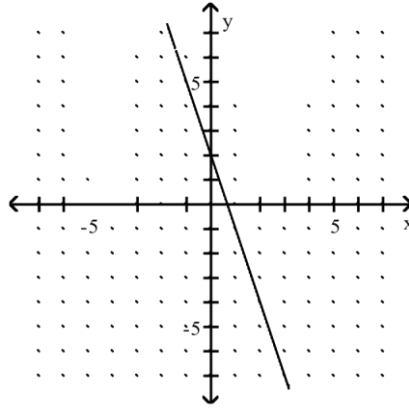
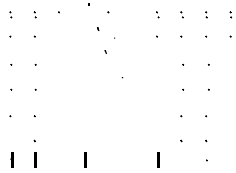

C)

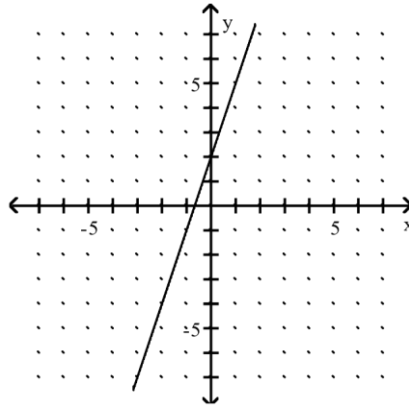

D)

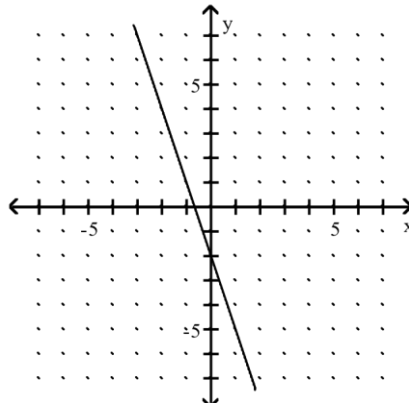

Answer: B

154) $h(x) = \frac{3}{4}x + 3$

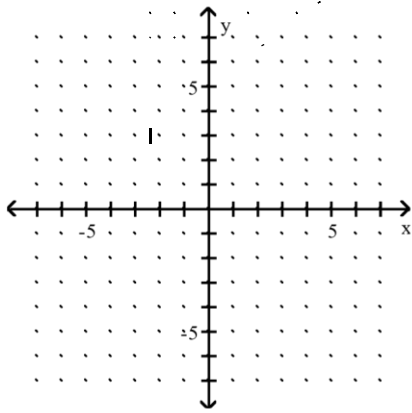

A)

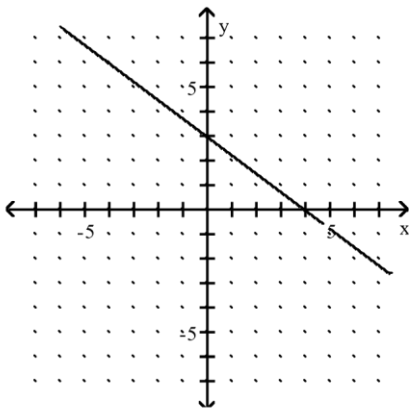

B)

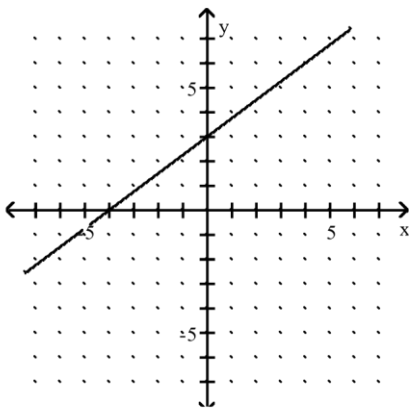

C)

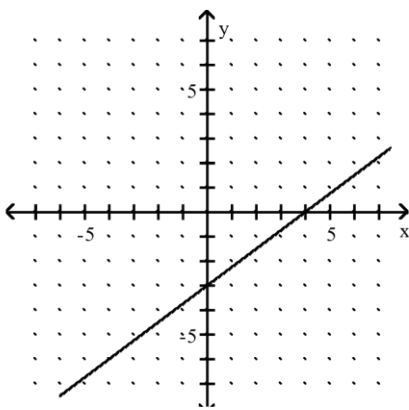

D)

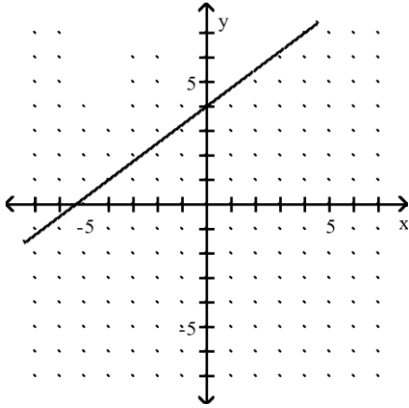

Answer: B

$$\frac{1}{2}h(x) = -x - 2$$

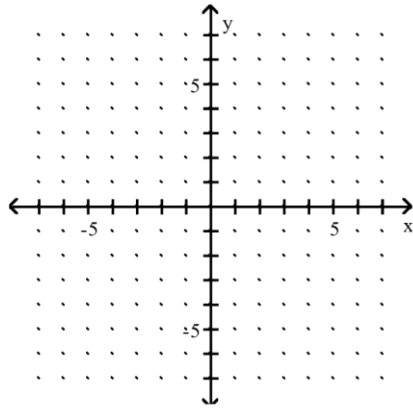

A)

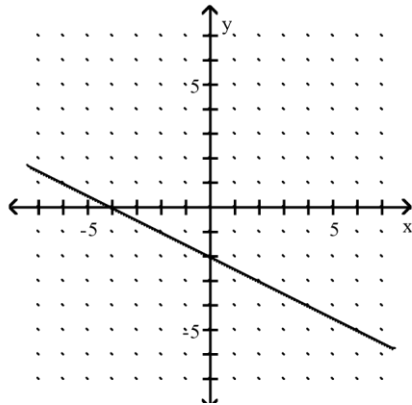

B)

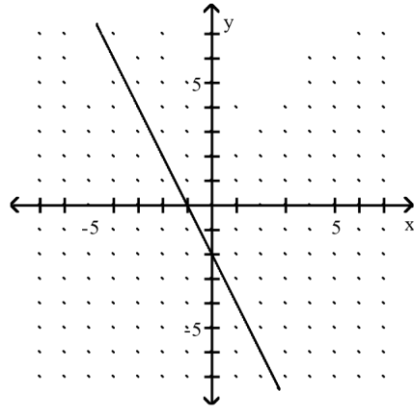
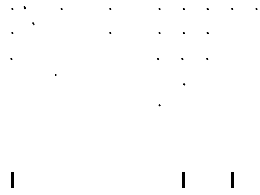

C)

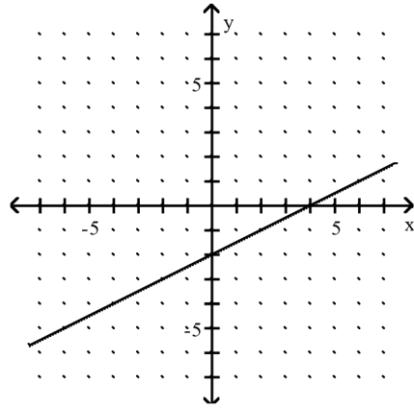

D)

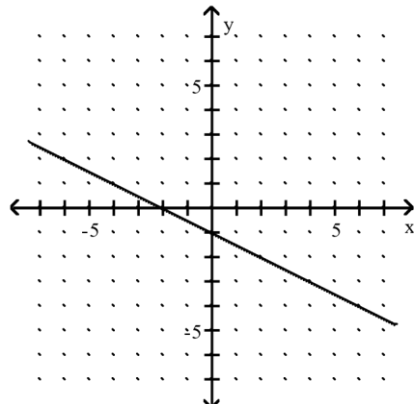

Answer: A 156) $-x + 4y = 24$

.....
.....
.....

l l

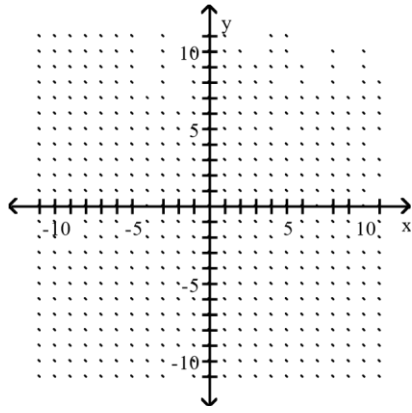

A)

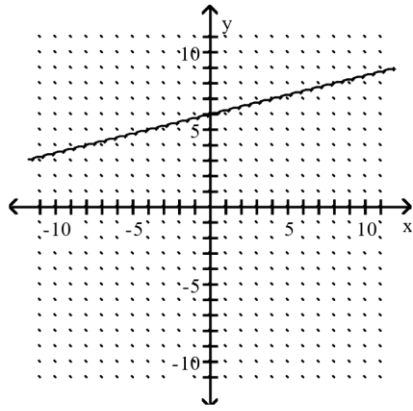

B)

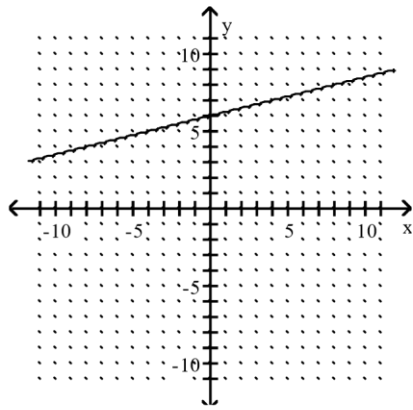

C)

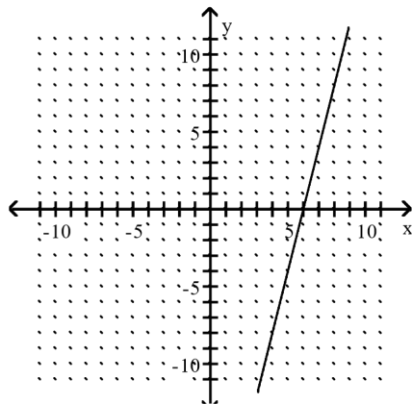

D)

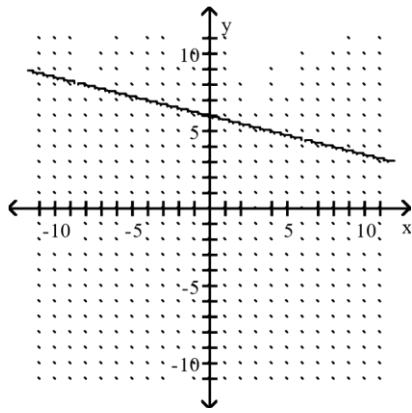

Answer: A

157) $7x - 6y = 42$

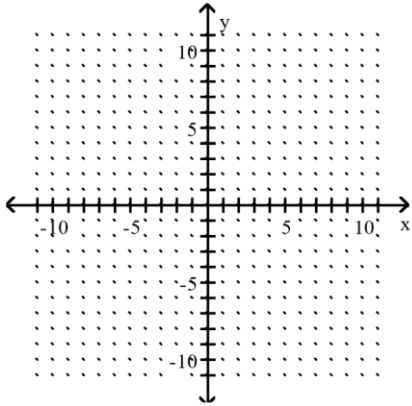

A)

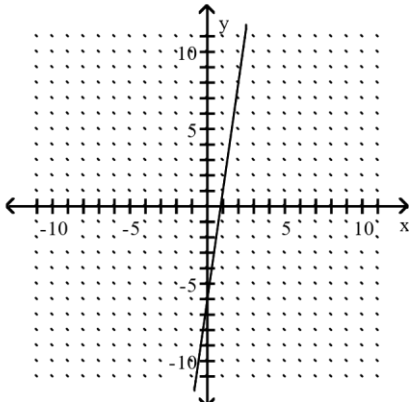

B)

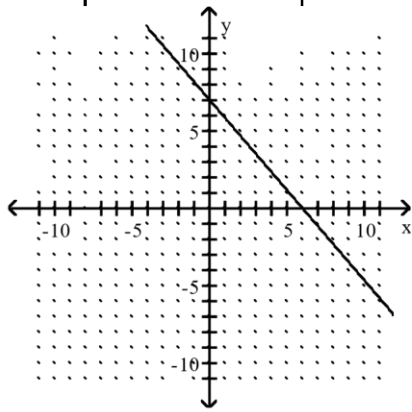

C)

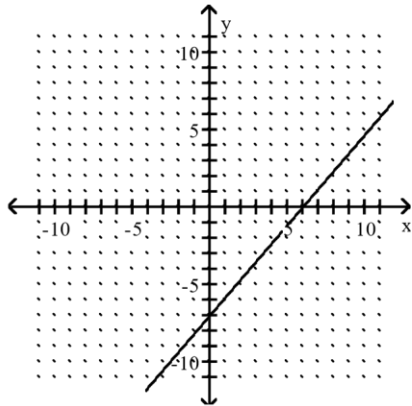

D)

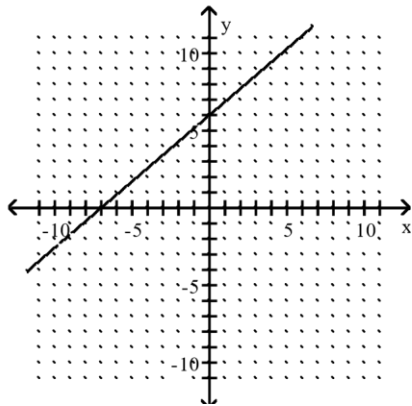

Answer: A B C D

Graph the equation in the rectangular coordinate system.

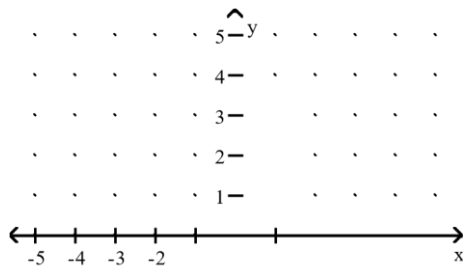

158) $x = 5$

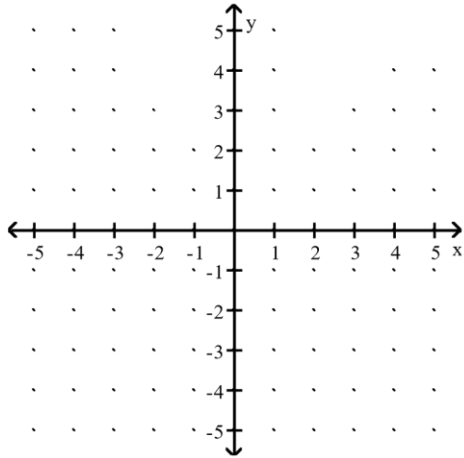

A)

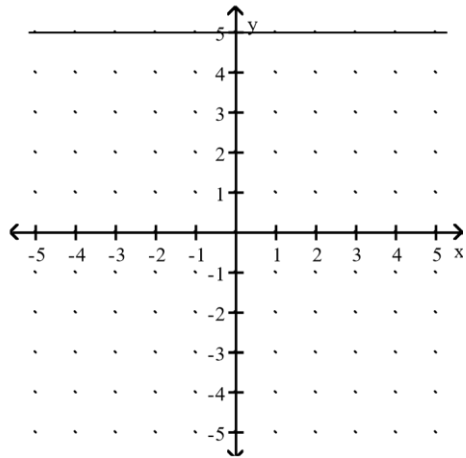

B)

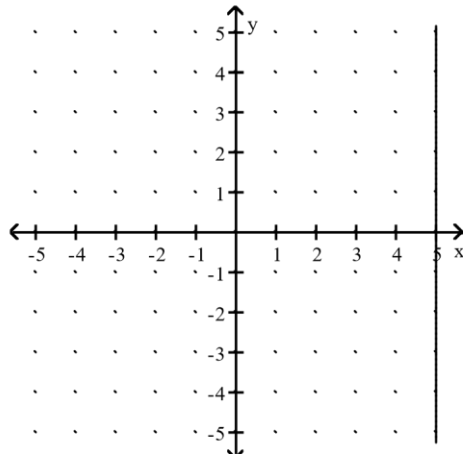

1
0
5

C)

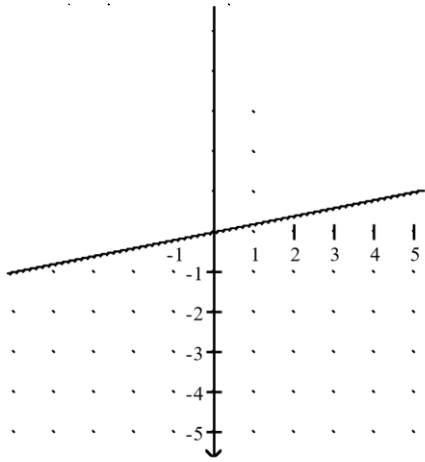

D)

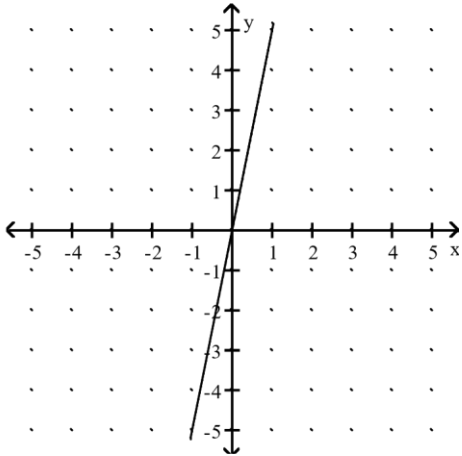

Answer: B

159) $y = 4$

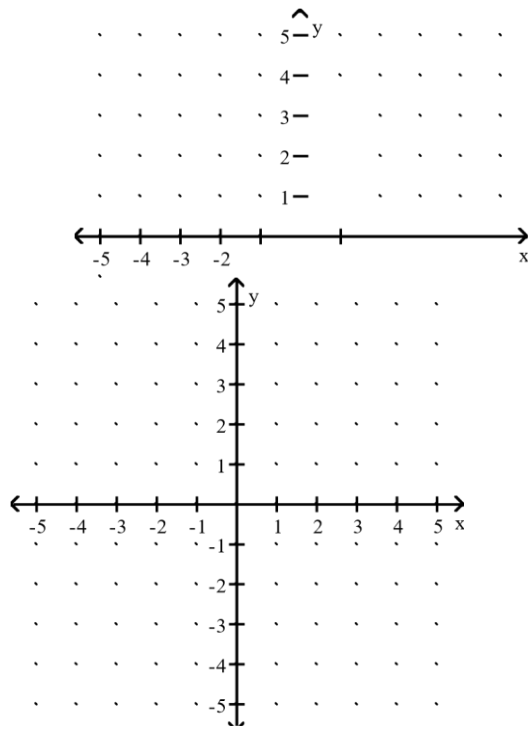

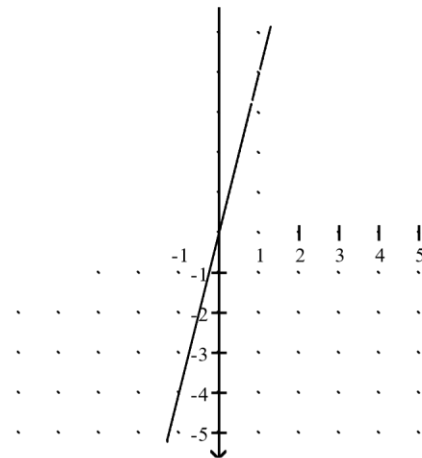
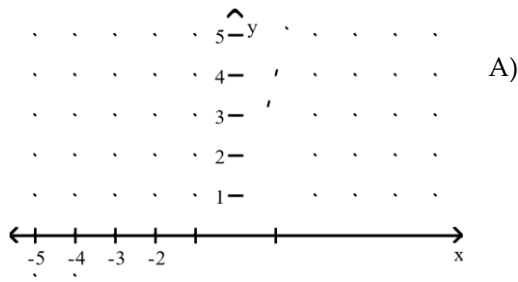

B)

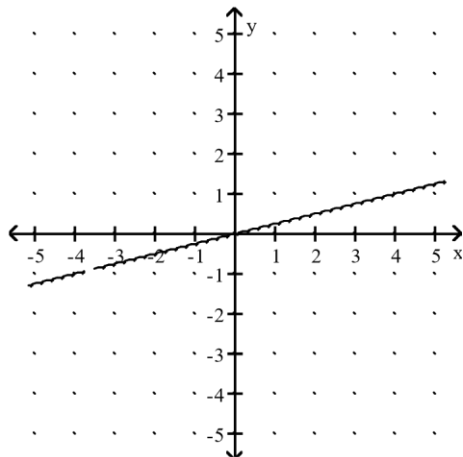

C)

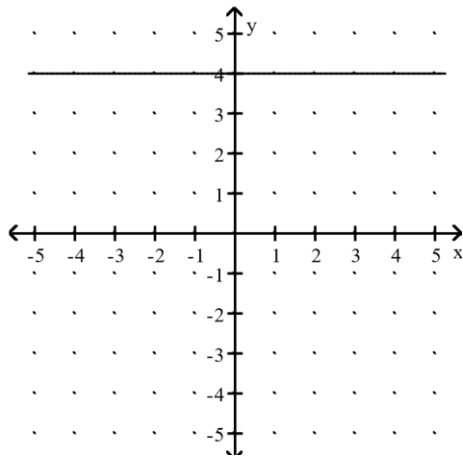

D)

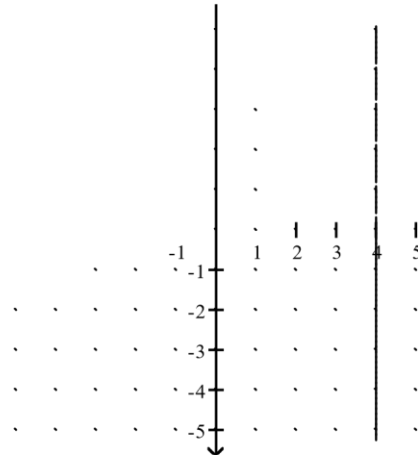
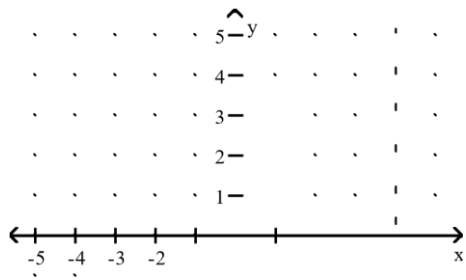

Answer: C

160) $f(x) = 3$

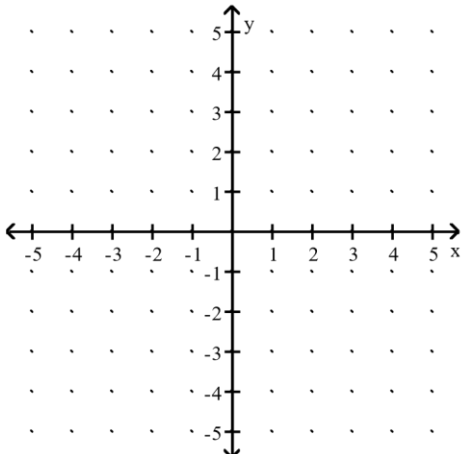

A)

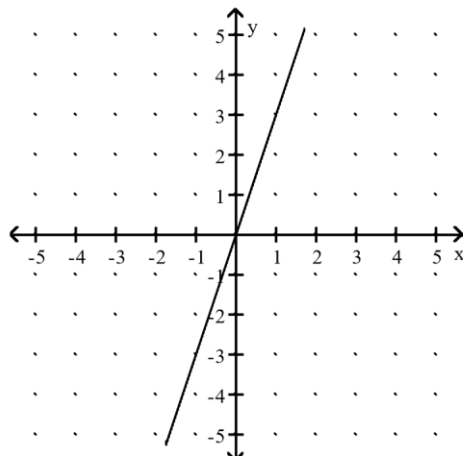

B)

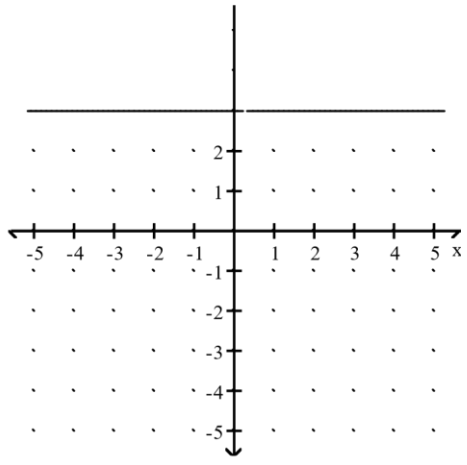
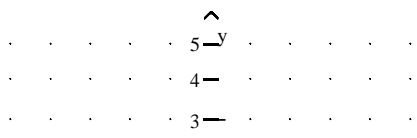

C)

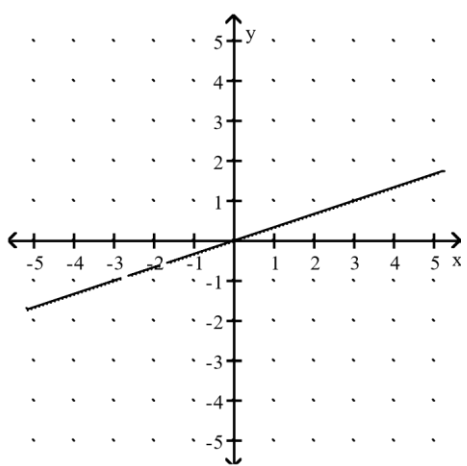

D)

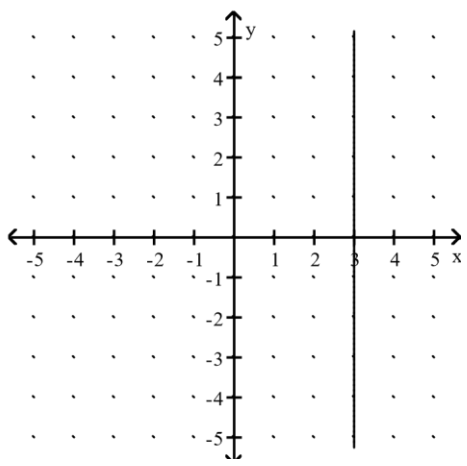

Answer: B

161) $4y = -12$

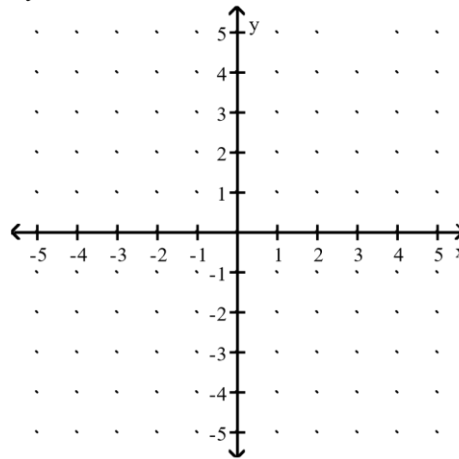

A)

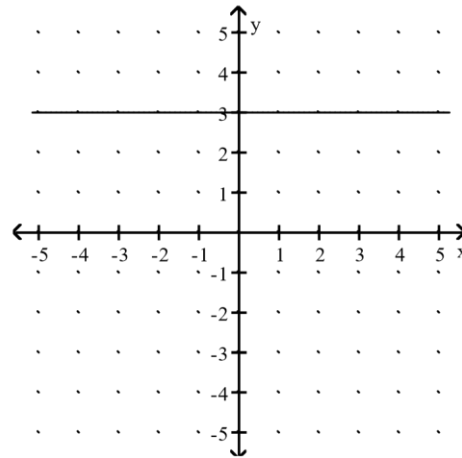

B)

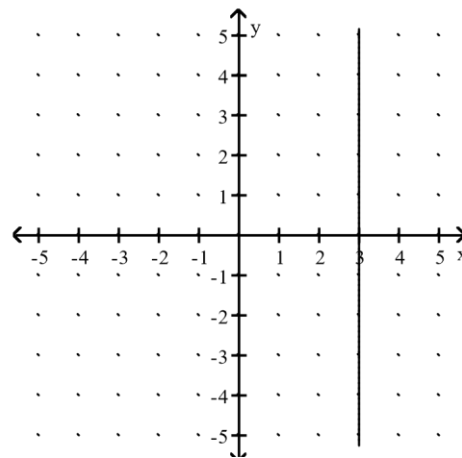

C)

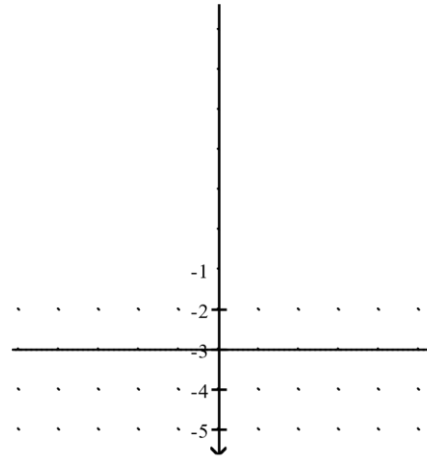
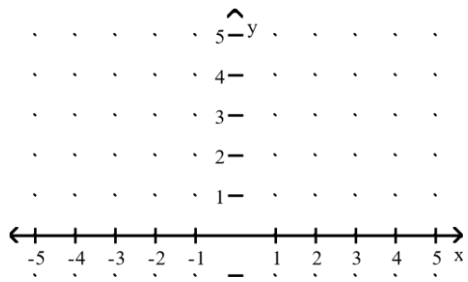

D)

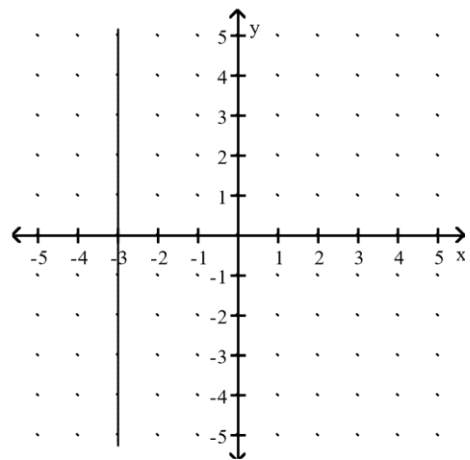

Answer: C

162) $4x = 8$

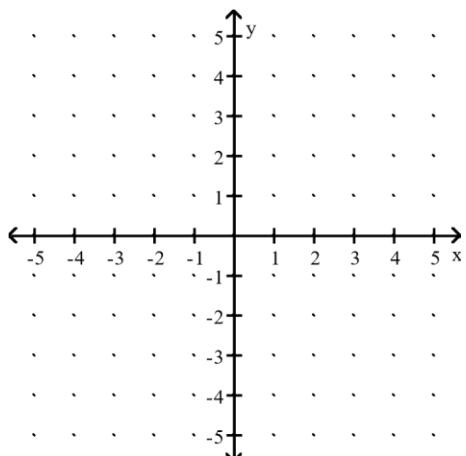

A)

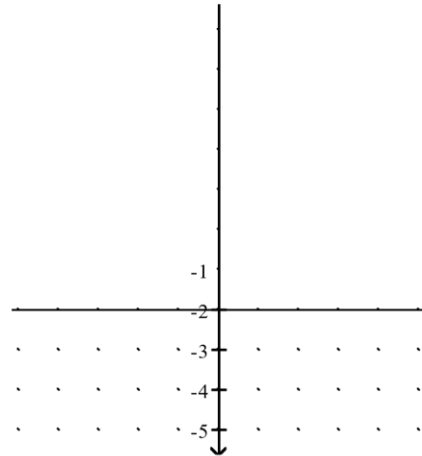
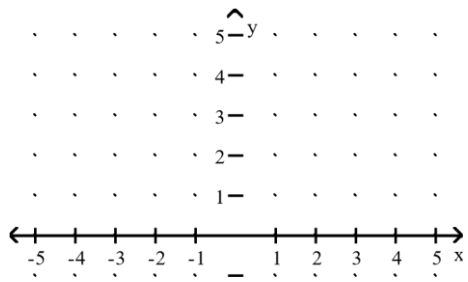

B)

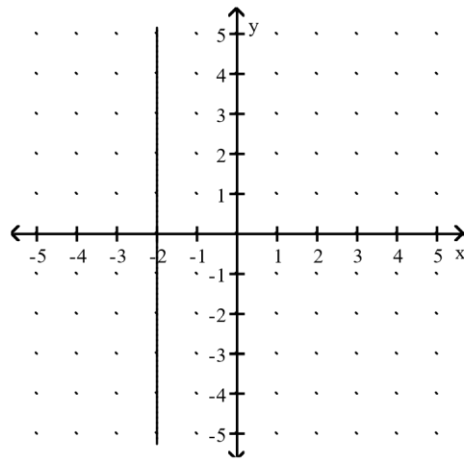

C)

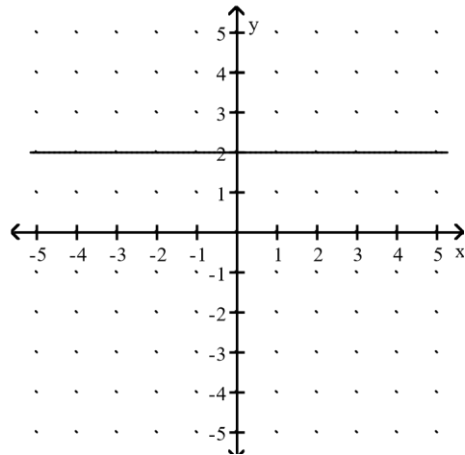

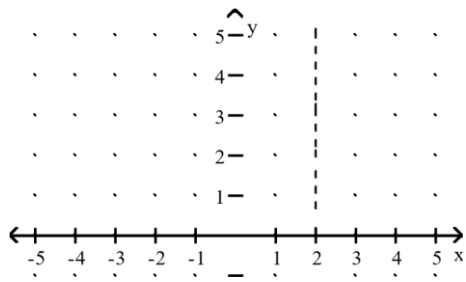

D)

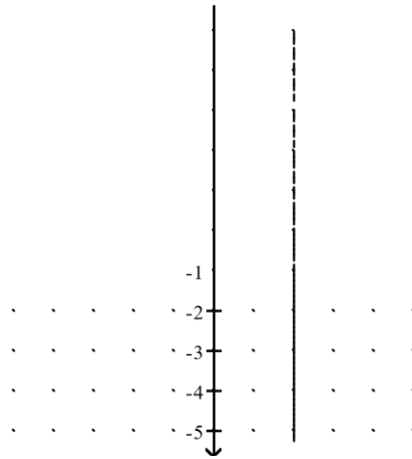

Answer: D

163) $-4y = -28$

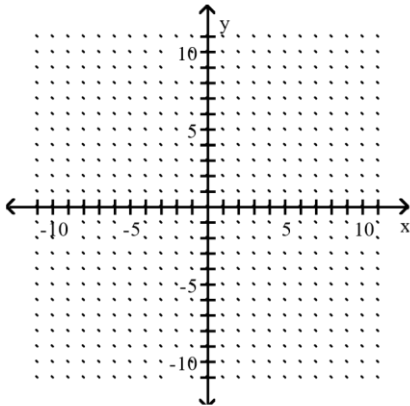

A)

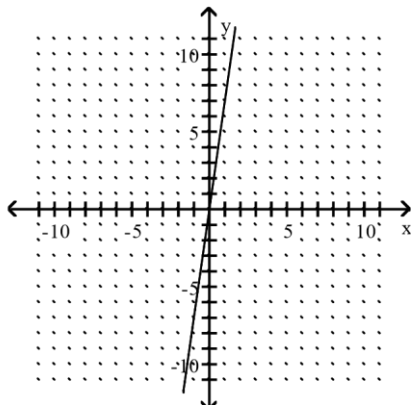

B)

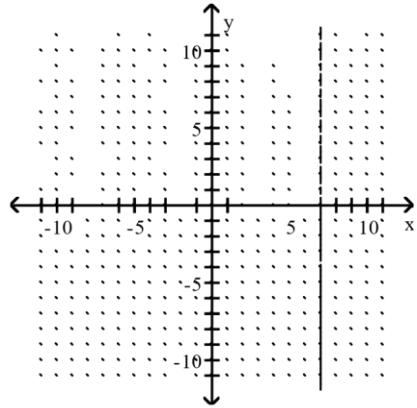
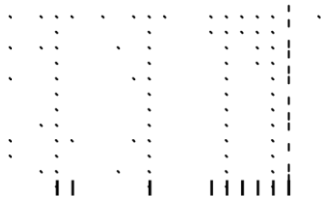

C)

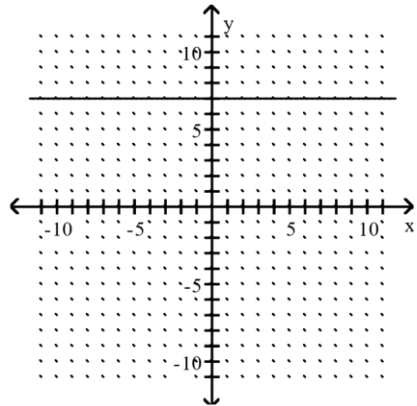

D)

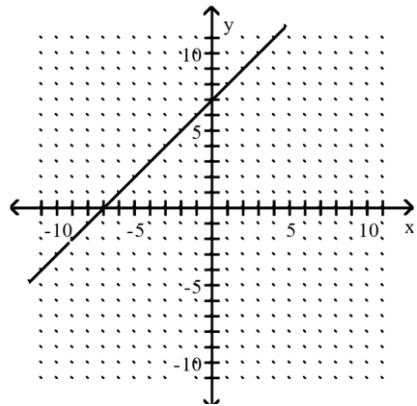

Answer: C

164) $3x - 5 = -11$

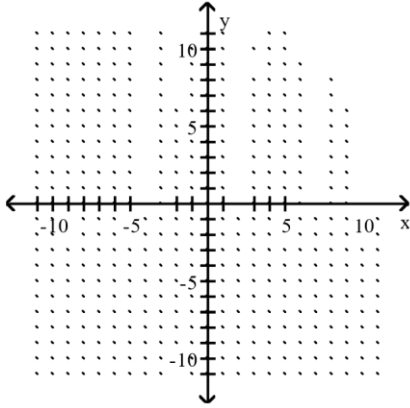

A)

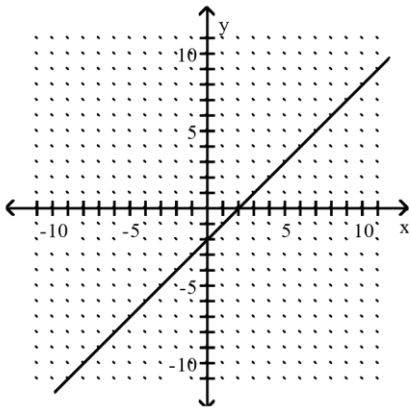

B)

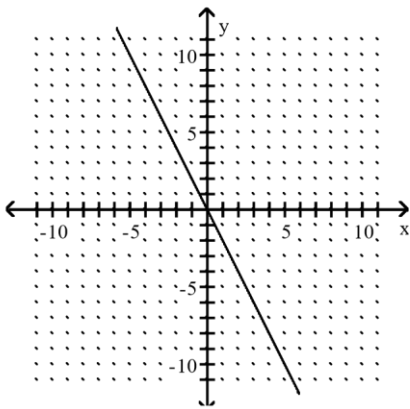

C)

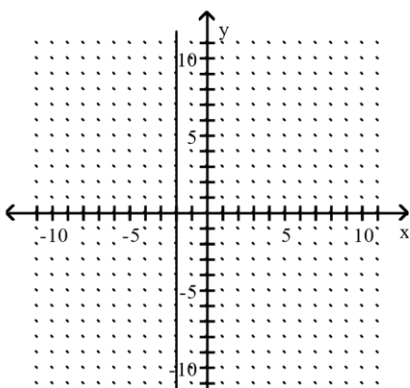

D)

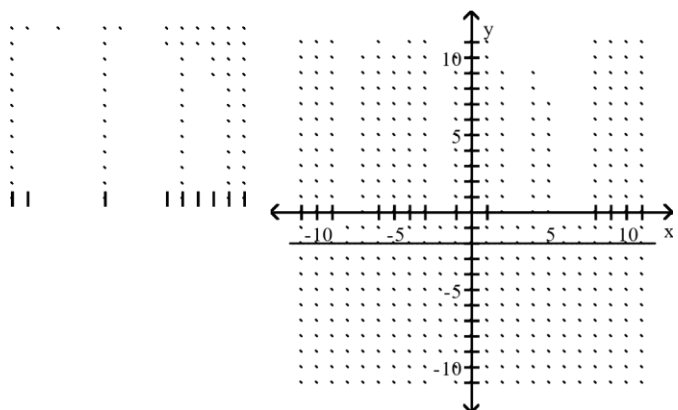

Answer: C

Find the slope then describe what it means in terms of the rate of change of the dependent variable per unit change in the independent variable.

165) The linear function $f(x) = 4.3x + 33$ represents the percentage of people, $f(x)$, who graduated from college x years after 1998.

- A) $m = -4.3$; the percentage of people graduating from college has decreased at a rate of 4.3% per year after 1998.
- B) $m = 4.3$; the percentage of people graduating from college has increased at a rate of 4.3% per year after 1998.
- C) $m = 4.3$; the percentage of people graduating from college has decreased at a rate of 4.3% per year after 1998.
- D) $m = 33$; the percentage of people graduating from college has increased at a rate of 33% per year after 1998.

Answer: B

166) The linear function $f(x) = -5.3x + 21$ models the percentage of people, $f(x)$, who eat at fast food restaurants each week x years after 1998.

- A) $m = 5.3$; the percentage of people eating at fast food restaurants each week has increased at a rate of -5.3% per year after 1998.
- B) $m = -5.3$; the percentage of people eating at fast food restaurants each week has decreased at a rate of -5.3% per year after 1998.
- C) $m = 21$; the percentage of people eating at fast food restaurants each week has increased at a rate of -5.3% per year after 1998.
- D) $m = 5.3$; the percentage of people eating at fast food restaurants each week has increased at a rate of 5.3% per year after 1998.

Answer: B

Solve the problem.

167) From April through December, the stock price of QRS Company had a roller coaster ride. The chart below indicates the price of the stock at the beginning of each month during that period. Find the monthly average rate of change in price between April and December.

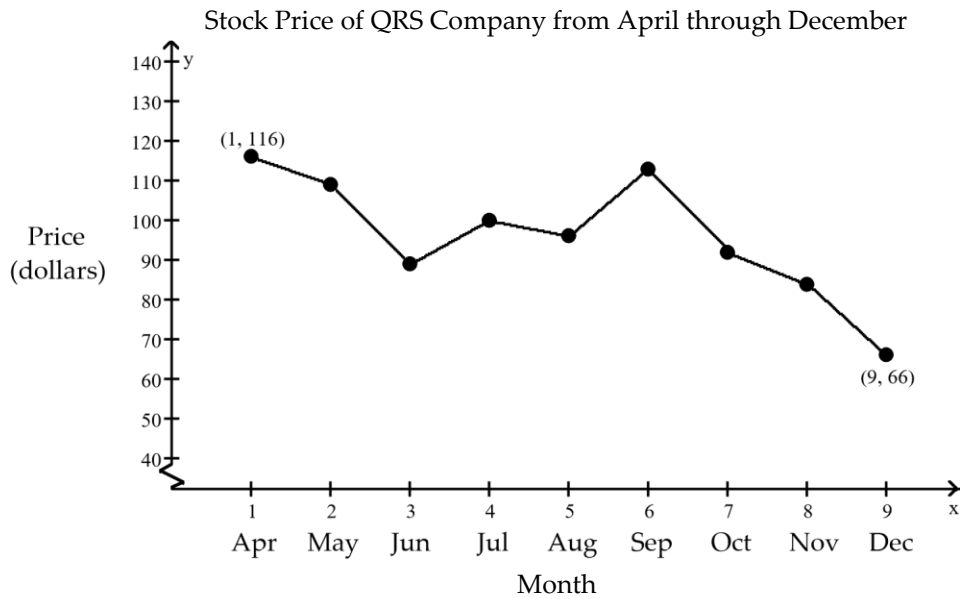

- A) \$6.25 per month
 B) -\$6.25 per month
 C) -\$5.56 per month D) \$5.56 per month

Answer: B

- 168) From April through December, the stock price of QRS Company had a roller coaster ride. The chart below indicates the price of the stock at the beginning of each month during that period. Find the monthly average rate of change in price between June and September.

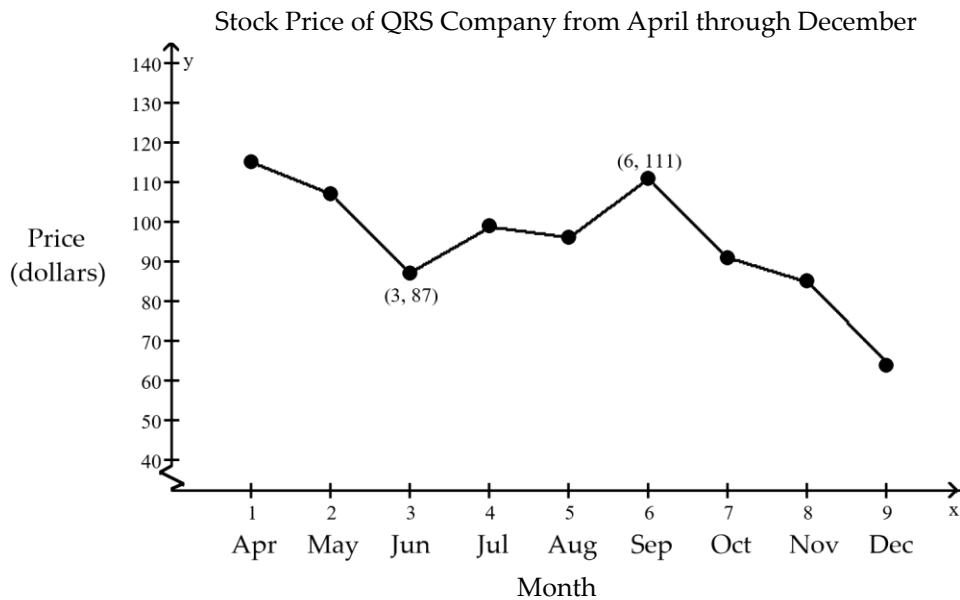

- A) \$12.00 per month
 B) -\$12.00 per month
 C) \$8.00 per month
 D) -\$8.00 per month

Answer: C

169) The total individual income tax collected by the tax collecting body of a country is a function of the number of people working, their income, and the tax rates. It has increased each year since 1985. The table below shows the individual income tax collected (in billions) for the time period between 1985 and 2010. Find the average annual rate of change between 1995 and 2005.

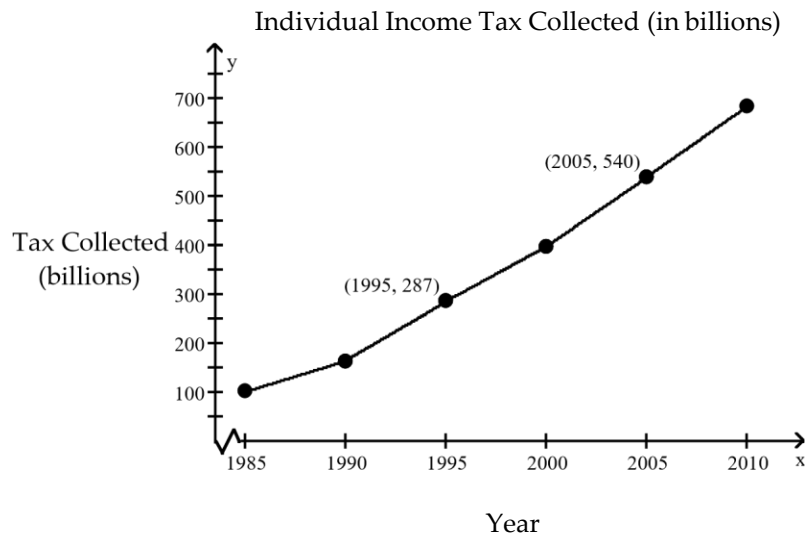

- A) \$39.8 billion per year
- B) \$37.8 billion per year
- C) \$34.9 billion per year
- D) \$25.3 billion per year

Answer: D

170) Along with incomes, people's charitable contributions have steadily increased over the past few years. The table below shows the average deduction for charitable contributions reported on individual income tax returns for the period 2007 to 2012. Find the average annual increase between 2009 and 2011.

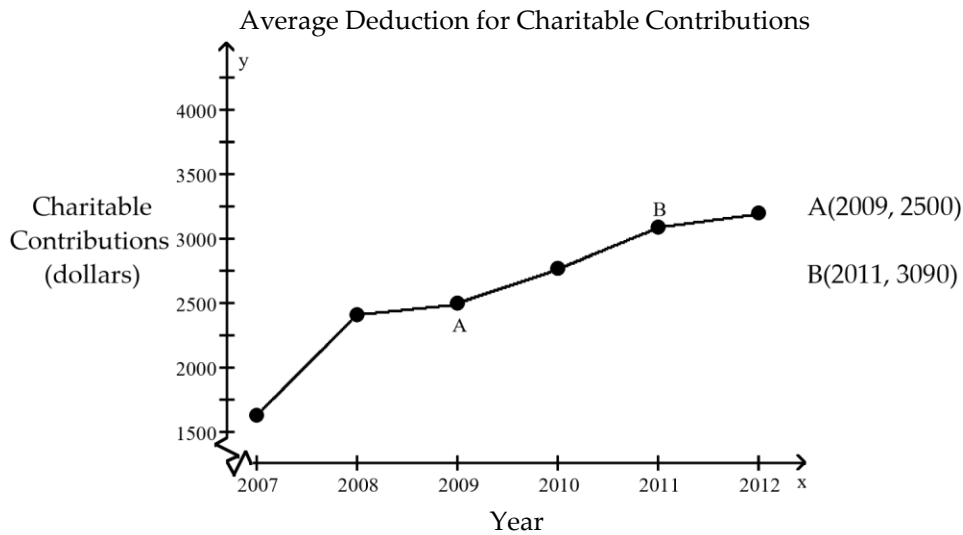

- A) \$340 per year
- B) \$295 per year
- C) \$590 per year
- D) \$350 per year

Answer: B

171) The price of a certain commodity is a function of supply and demand. The table below shows the price of the commodity per barrel between 2005 and 2010. Find the average annual rate of change between 2006 and 2008.

Price of the Commodity per Barrel

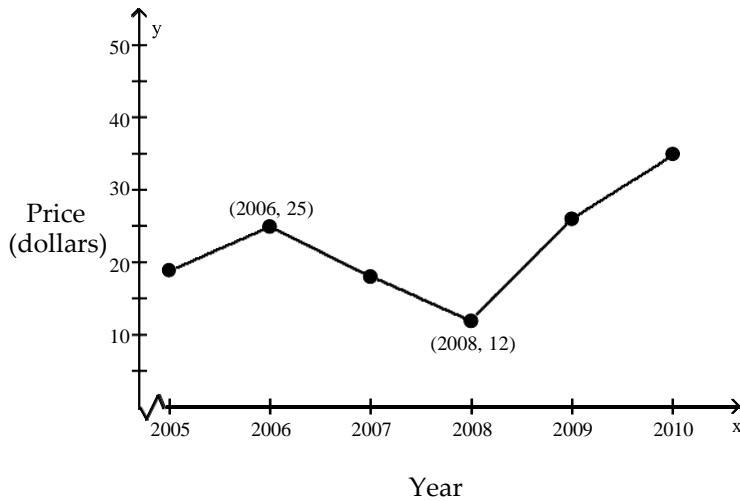

- A) \$2.50 per year
- B) -\$13.00 per year
- C) \$6.50 per year

D) -\$6.50 per year

Answer: D

- 172) The price of a certain commodity is a function of supply and demand. The table below shows the price of the commodity per barrel between 2005 and 2010. Find the average annual rate of change between 2008 and 2010.

Price of the Commodity per Barrel

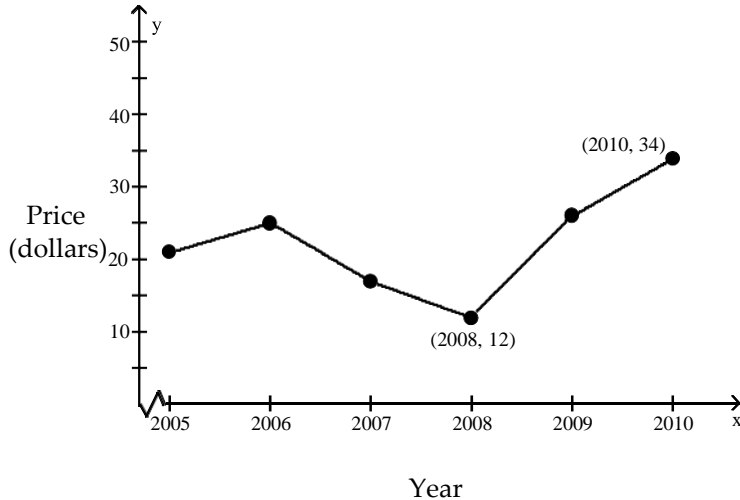

- A) \$2.25 per year
B) -\$11.00 per year
C) \$11.00 per year
D) \$22.00 per year

Answer: C

- 173) A truck rental company rents a moving truck one day by charging \$25 plus \$0.07 per mile. Write a linear equation that relates the cost C , in dollars, of renting the truck to the number x of miles driven. What is the cost of renting the truck if the truck is driven 220 miles?

- A) $C(x) = 0.07x + 25$; \$26.54
B) $C(x) = 0.07x - 25$; -\$9.60
C) $C(x) = 25x + 0.07$; \$5500.07
D) $C(x) = 0.07x + 25$; \$40.40

Answer: D

- 174) Linda needs to have her car towed. Little Town Auto charges a flat fee of \$75 plus \$2 per mile towed. Write a function expressing Linda's towing cost, C , in terms of miles towed, x . Find the cost of having a car towed 14 miles.

- A) $C(x) = 2x + 75$; \$93
B) $C(x) = 2x + 75$; \$103
C) $C(x) = 2x$; \$28
D) $C(x) = 2 + 75$; \$77

Answer: B

- 175) The following bar graph shows the average annual income for single mothers.

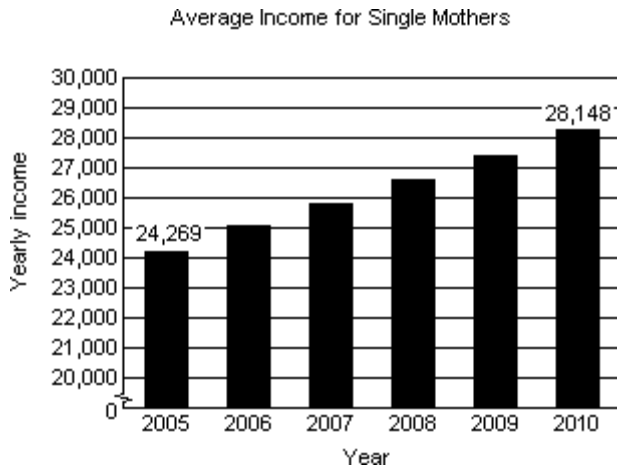

- i) Determine a linear function that can be used to estimate the average yearly income for single mothers from 2005 through 2010. Let t represent the number of years from 2005. (In other words, 2005 corresponds to $t = 0$, 2006 corresponds to $t = 1$, and so on.) ii) Using the function from part i, determine the average yearly income for single mothers in 2006. iii) Assuming this trend continues, determine the average yearly income for single mothers in 2016. iv) Assuming this trend continues, in which year will the average yearly income for single mothers reach \$34,000?

- A) i) $I(t) = 775.8t + 24,269$ ii) \$25,820.60
iii) \$32,802.80 iv) 2020
- B) i) $I(t) = 775.8t + 24,269$ ii) \$25,044.80
iii) \$32,802.80 iv) 2020
- C) i) $I(t) = 770.8t + 24,269$ ii) \$25,039.80
iii) \$32,747.80 iv) 2020
- D) i) $I(t) = 775.8t + 24,269$ ii) \$25,044.80
iii) \$32,802.80 iv) 2021

Answer: B

- 176) The gas mileage, m , of a compact car is a linear function of the speed, s , at which the car is driven, for $40 \leq s \leq 90$. For example, from the graph we see that the gas mileage for the compact car is 45 miles per gallon if the car is driven at a speed of 40 mph.

Gas Mileage of a Compact Car

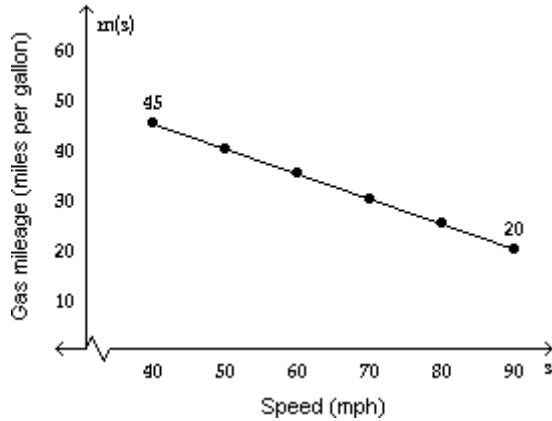

- i) Using the two points on the graph, determine the function $m(s)$ that can be used to approximate the graph. ii) Using the function from part i, estimate the gas mileage if the compact car is traveling 81 mph. If necessary, round to the nearest tenth. iii) Using the function from part i, estimate the speed of the compact car if the gas mileage is 36 miles per gallon. If necessary, round to the nearest tenth.

- A) i) $m(s) = -\frac{1}{2}s + 65$
 ii) 24.5 miles per gallon
 iii) 58 mph
- B) i) $m(s) = -\frac{1}{2}s + 65$
 ii) 105.5 miles per gallon
 iii) 58 mph
- C) i) $m(s) = \frac{1}{2}s + 65$
 ii) 105.5 miles per gallon
 iii) 58 mph
- D) i) $m(s) = -\frac{1}{2}s + 65$
 ii) 24.5 miles per gallon
 iii) 63 mph

Answer: A

- 177) The graph shows that the cost of the average college mathematics textbook has been rising steadily since 2000.

Average Cost of a College

Mathematics Textbook

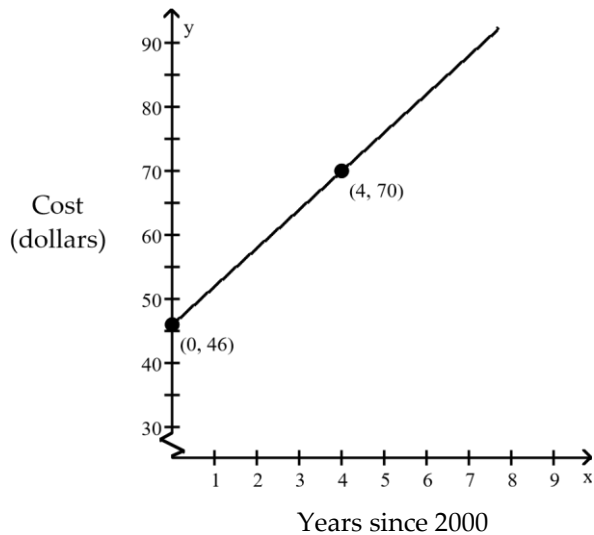

Predict the cost of an average college mathematics textbook in year 2028.

- A) \$298
- B) \$214
- C) \$444
- D) \$122

Answer: B

Write the point-slope form of the line satisfying the conditions. Then use the point-slope form of the equation to write the slope-intercept form of the equation in function notation.

178) Slope = -3, passing through (5, 4)

- A) $f(x) = -3x + 19$
- B) $f(x) = -\frac{1}{3}x - \frac{19}{3}$
- C) $f(x) = 3x - 19$
- D) $f(x) = -3x - 19$

Answer: A

179) Slope = $\frac{4}{5}$, passing through (2, -3)

- A) $f(x) = -\frac{4}{5}x + \frac{23}{5}$
- B) $f(x) = \frac{4}{5}x - \frac{23}{5}$
- C) $f(x) = -\frac{5}{4}x - \frac{23}{4}$
- D) $f(x) = -\frac{4}{5}x - \frac{23}{5}$

Answer: B

180) Slope = $\frac{7}{8}$, passing through (0, 4)

- A) $f(x) = \frac{7}{8}x - 4$
- B) $f(x) = \frac{7}{8}x + 4$
- C) $f(x) = -\frac{7}{8}x - 4$
- D) $f(x) = \frac{8}{7}x + \frac{32}{7}$

Answer: B

181) Slope = $-\frac{6}{7}$, passing through (0, 2)

- A) $f(x) = -\frac{7}{6}x - \frac{7}{3}$
- B) $f(x) = -\frac{6}{7}x + 2$
- C) $f(x) = -\frac{6}{7}x - 2$
- D) $f(x) = \frac{6}{7}x - 2$

Answer: B

182) Slope = -6, passing through (5, 2)

- A) $f(x) = 6x - 32$
- B) $f(x) = -6x + 32$
- C) $f(x) = -6x - 32$
- D) $f(x) = -\frac{1}{6}x - \frac{16}{3}$

Answer: B

183) Passing through (-9, -3) and (-1, -3) A) $f(x) = -1$

- B) $f(x) = 0$
- C) $f(x) = -3$
- D) $f(x) = -9$

Answer: C

184) Passing through (10, 75) and (8, 61)

- A) $f(x) = 7x + 5$
- B) $f(x) = -7x + 145$
- C) $f(x) = \frac{1}{7}x + \frac{515}{7}$
- D) $f(x) = -\frac{1}{7}x + \frac{535}{7}$

Answer: A

185) Passing through (-10, -45) and (8, 27)

A) $f(x) = \frac{1}{4}x - \frac{85}{2}$

B) $f(x) = 4x - 5$

C) $f(x) = -\frac{1}{4}x - \frac{95}{2}$

D) $f(x) = -4x - 85$

Answer: B

186) Passing through (6, -41) and (4, -27)

A) $f(x) = 7x - 83$

B) $f(x) = -7x + 1$

C) $f(x) = \frac{1}{7}x - \frac{293}{7}$

D) $f(x) = -\frac{1}{7}x - \frac{281}{7}$

Answer: B

187) Passing through (7, -31) and (-5, 17)

A) $f(x) = \frac{1}{4}x - \frac{131}{4}$

B) $f(x) = -4x - 3$

C) $f(x) = -\frac{1}{4}x - \frac{117}{4}$

D) $f(x) = 4x - 59$

Answer: B

188) Passing through (0, 0) and $\left(\frac{5}{8}, 5\right)$,

A) $f(x) = 8$

B) $f(x) = \frac{1}{8}x$

C) $f(x) = 8x$

D) $f(x) = \frac{1}{8}$

Answer: B

Solve.

189) The average value of a certain type of automobile was \$14,220 in 2008 and depreciated to \$5220 in 2012. Let y be the average value of the automobile in the year x , where $x = 0$ represents 2008. Write a linear equation that models the value of the automobile in terms of the year x .

A) $y = -2250x + 5220$

B) $y = -2250x + 14,220$

$$C) y = -\frac{1}{2250}x - 5220$$

$$D) y = -2250x - 3780$$

Answer: B

- 190) An investment is worth \$3354 in 2007. By 2011 it has grown to \$4210. Let y be the value of the investment in the year x , where $x = 0$ represents 2007. Write a linear equation that models the value of the investment in the year x .

$$A) y = -214x + 5066$$

$$B) y = \frac{1}{214}x + 3354$$

$$C) y = 214x + 3354$$

$$D) y = -214x + 3354$$

Answer: C

- 191) A faucet is used to add water to a large bottle that already contained some water. After it has been filling for 5 seconds, the gauge on the bottle indicates that it contains 17 ounces of water. After it has been filling for 12 seconds, the gauge indicates the bottle contains 38 ounces of water. Let y be the amount of water in the bottle x seconds after the faucet was turned on. Write a linear equation that models the amount of water in the bottle in terms of x .

$$A) y = 3x + 2$$

$$B) y = 3x + 26$$

$$C) y = -3x + 32$$

$$D) y = \frac{1}{3}x + \frac{46}{3}$$

Answer: A

- 192) When making a telephone call using a calling card, a call lasting 4 minutes cost \$0.85. A call lasting 13 minutes cost \$1.75. Let y be the cost of making a call lasting x minutes using a calling card. Write a linear equation that models the cost of a making a call lasting x minutes.

$$A) y = 0.1x + 0.45$$

$$B) y = -0.1x + 1.25$$

$$C) y = 10x - \frac{783}{20}$$

$$D) y = 0.1x - 11.25$$

Answer: A

- 193) A vendor has learned that, by pricing carmel apples at \$1.75, sales will reach 107 carmel apples per day. Raising the price to \$2.50 will cause the sales to fall to 74 carmel apples per day. Let y be the number of carmel apples the vendor sells at x dollars each. Write a linear equation that models the number of carmel apples sold per day when the price is x dollars each.

$$A) y = -\frac{1}{44}x + \frac{18825}{176}$$

$$B) y = -44x - 184$$

C) $y = -44x + 184$ D) $y = 44x + 30$

Answer: C

194) A vendor has learned that, by pricing hot dogs at \$1.00, sales will reach 111 hot dogs per day. Raising the price to \$1.50 will cause the sales to fall to 91 hot dogs per day. Let y be the number of hot dogs the vendor sells at x dollars each. Write a linear equation that models the number of hot dogs sold per day when the price is x dollars each.

A) $y = -40x + 151$

B) $y = 40x + 71$

C) $y = -\frac{1}{40}x + \frac{4439}{40}$

D) $y = -40x - 151$

Answer: A

Find the slope.

195) Find the slope of a line parallel to the line $y = \frac{2}{9}x - 3$.

A) $\frac{2}{9}$

B) -3

C) undefined

D) $-\frac{9}{2}$

Answer: A

196) Find the slope of a line parallel to the line $y = \frac{2}{5}x$.

A) 0

B) $\frac{2}{5}$

C) undefined

D) $-\frac{5}{2}$

Answer: B

197) Find the slope of a line perpendicular to the line $y = -8x + 4$.

A) undefined

B) 4

C) $\frac{1}{8}$

D) -8

Answer: C

198) Find the slope of a line perpendicular to the line $y = -\frac{1}{5}x$.

A) undefined

B) 5

C) 0

D) $-\frac{1}{5}$ Answer: B 199) Find the slope of a line parallel to the line $4x + 7y = -7$.

A) -7

B) undefined

C) $\frac{7}{4}$

D) $-\frac{4}{7}$

Answer: D

200) Find the slope of a line perpendicular to the line $-5x + 2y = -1$.

A) $-\frac{2}{5}$

B) $\frac{2}{5}$

C) -1

D) undefine

d Answer: A

201) Find the slope of a line parallel to the line $x = 5$.

A) 0

B) 5

C) undefined

D) $\frac{1}{5}$

Answer: C

202) Find the slope of a line parallel to the line $y = -3$.

A) undefined B) -3

C) 0

D) $-\frac{1}{3}$

Answer: C

203) Find the slope of a line perpendicular to the line $x = -3$.

A) -3 B) undefined

C) 0

D) $-\frac{1}{3}$

Answer: C

204) Find the slope of a line perpendicular to the line $y = 5$.

A) $\frac{1}{5}$

B) undefined

C) 5

D) 0

Answer: B

Use the given conditions to write an equation for the line in slope-intercept form.

205) Passing through (4, 3) and parallel to the line whose equation is $y = -9x$.

A) $y = 9x - 39$ B)

$y = -\frac{1}{9}x - \frac{13}{3}$

C) $y = -9x + 39$

D) $y = -9x - 39$

Answer: C

206) Passing through (4, 2) and perpendicular to the line whose equation is $y = 9x$.

A) $y = -\frac{1}{9}x - \frac{22}{9}$

B) $y = -9x - 22$

C) $y = \frac{1}{9}x - \frac{22}{9}$ D) $y = -\frac{1}{9}x + \frac{22}{9}$

Answer: D

207) Passing through (2, 3) and parallel to the line whose equation is $y = -3x + 3$.

A) $y = 3x - 9$

B) $y = -\frac{1}{3}x - 3$

C) $y = -3x + 9$

D) $y = -3x - 9$

Answer: C

208) Passing through (2, -3) and parallel to the line whose equation is $y = -4x + 3$.

A) $y = -4x - 5$ B)

$y = 4x - 5$

C) $y = -\frac{1}{4}x - \frac{5}{4}$

D) $y = -4x + 5$

Answer: D

209) Passing through (4, 4) and perpendicular to the line whose equation is $y = 4x + 5$.

- A) $y = \frac{1}{4}x - 5$
- B) $y = -4x - 20$
- C) $y = -\frac{1}{4}x - 5$
- D) $y = -\frac{1}{4}x + 5$

Answer: D

210) Passing through (3, 4) and perpendicular to the line whose equation is $y = \frac{1}{2}x + 5$.

- A) $y = 2x - 10$
- B) $y = -2x + 10$
- C) $y = -2x - 10$
- D) $y = -\frac{1}{2}x - 5$

Answer: B

211) Passing through (2, 4) and parallel to the line whose equation is $y = -\frac{1}{9}x + 5$.

- A) $y = -9x - 38$
- B) $y = -\frac{1}{9}x + \frac{38}{9}$
- C) $y = \frac{1}{9}x - \frac{38}{9}$
- D) $y = -\frac{1}{9}x - \frac{38}{9}$

Answer: B

Find an equation for the line with the given properties.

212) The solid line L contains the point (-2, 4) and is perpendicular to the dotted line whose equation is $y = 2x$. Give the equation of line L in slope-intercept form.

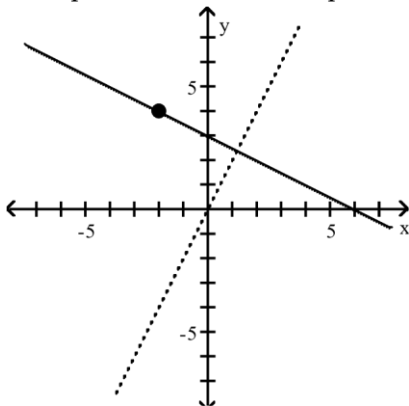

- A) $y - 4 = -\frac{1}{2}(x + 2)$
- B) $y - 4 = 2(x + 2)$

C) $y = -\frac{1}{2}x + 3$

D) $y = \frac{1}{2}x + 3$

Answer: C

213) The solid line L contains the point (3, 5) and is parallel to the dotted line whose equation is $y = 2x$. Give the equation for the line L in slope-intercept form.

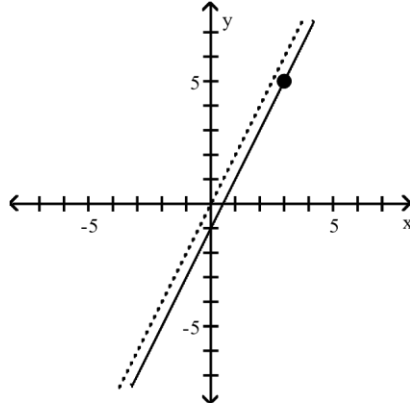

A) $y - 5 = 2(x - 3)$ B)

$y = 2x + 2$

C) $y = 2x - 1$

D) $y = 2x +$

b Answer: C

Determine whether the relation is a function. Give domain and range of the relation.

214) $\{(-3, -8), (0, 3), (3, 2), (6, -2)\}$

A) function; domain: $\{-8, 3, 2, -2\}$, range: $\{-3, 0, 3, 6\}$ B)

not a function; domain: $\{-8, 3, 2, -2\}$, range: $\{-3, 0, 3, 6\}$

C) not a function; domain: $\{-3, 0, 3, 6\}$, range: $\{-8, 3, 2, -2\}$

D) function; domain: $\{-3, 0, 3, 6\}$, range: $\{-8, 3, 2, -2\}$

Answer: D

215) $\{(41, -3), (5, -2), (5, 0), (9, 2), (21, 4)\}$

A) function; domain: $\{41, 9, 5, 21\}$, range: $\{-3, -2, 0, 2, 4\}$ B)

not a function; domain: $\{41, 9, 5, 21\}$, range: $\{-3, -2, 0, 2, 4\}$

C) function; domain: $\{-3, -2, 0, 2, 4\}$, range: $\{41, 9, 5, 21\}$

D) not a function; domain: $\{-3, -2, 0, 2, 4\}$, range: $\{41, 9, 5, 21\}$

Answer: B

Evaluate the function.

216) If $g(x) = 2x + 2$, find $g(a + 1)$.

A) $2a + 3$

B) $2a + 6$

C) $2a + 4$

D) $2a + 2$ Answer: C

217) If $f(x) = x^2 + 3x - 3$, find $f(4)$.

- A) 31
- B) 7
- C) 25
- D) 1

Answer: C

Graph the given functions in the same rectangular coordinate system. Describe how the graph of g is related to the graph of f .

218) $f(x) = 3x^2$, $g(x) = 3x^2 - 4$

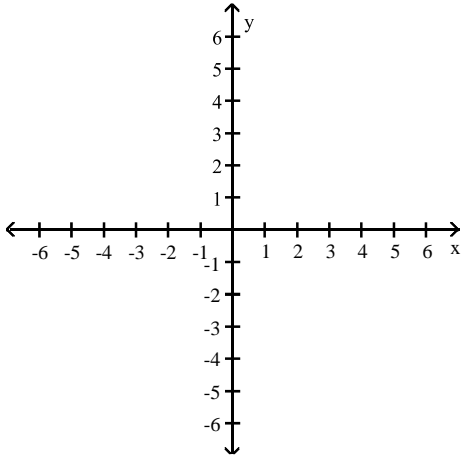

- A) g is the graph of f shifted down 4 units

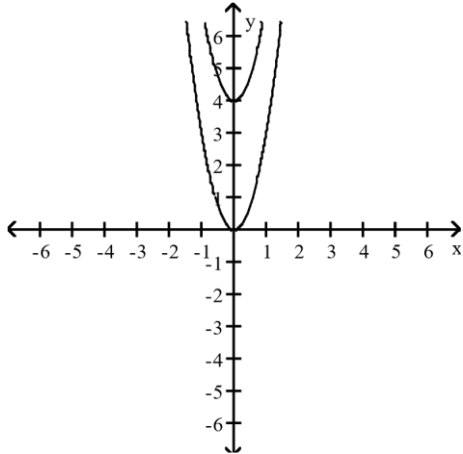

- B) g is the graph of f shifted up 4 units

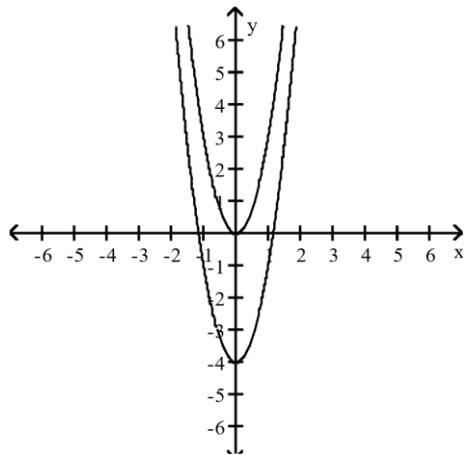

C) g is the graph of f shifted down 4 units

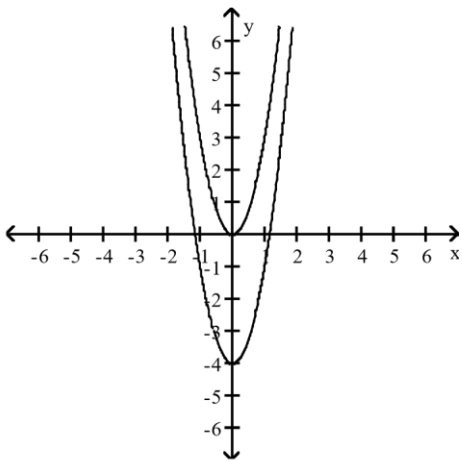

D) g is the graph of f shifted up 4 units

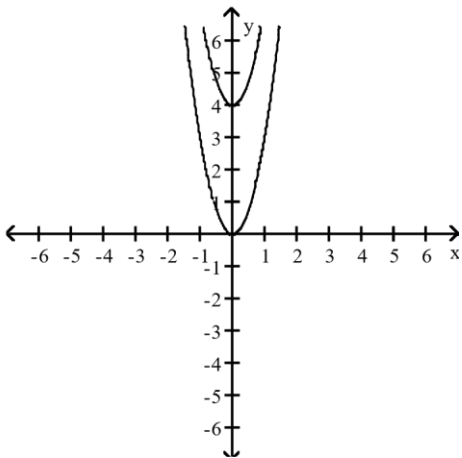

Answer: C

Determine if the graph represents y as a function of x .

219)

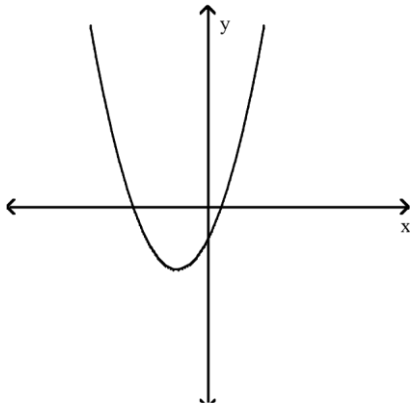

A) Function

B) Not

a

functi

on.....2

A) 2

B) 3

C) -1.....3

D) 1.....3

Answer: A

220)

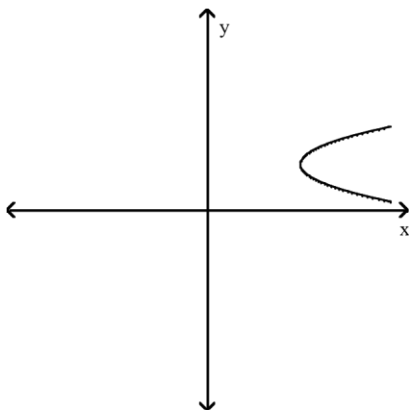

A) Not a
function

B) Function

Answer: A

Use the graph of f to solve.

221) Find $f(-4)$

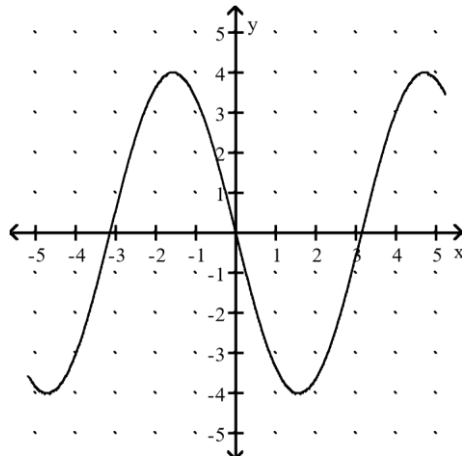

Answer: B

222) List the two values of x for which $f(x) = 0$

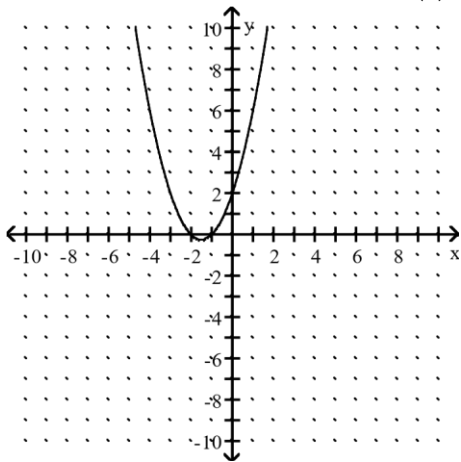

- A) -2 and -1
- B) 2 and -1
- C) 2 and 1
- D) -2 and 1

Answer: A

223) Find the domain of f .

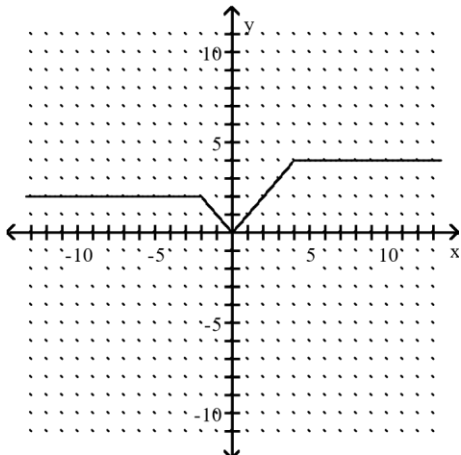

A) $[0, 4]$

B) $[2, 4]$

C) $(0, 4)$

D) $(-\infty, \infty)$

Answer: D

224) Find the range of f .

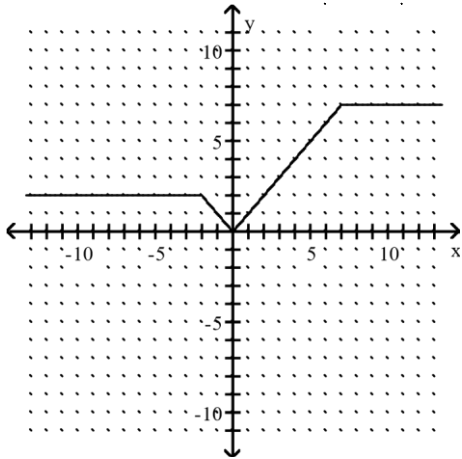

- A) $[0, 7]$
- B) $(-\infty, \infty)$
- C) $[2, 7]$
- D) $(0, 7)$

Answer: A

Find the domain of the function.

225) $f(x) = \frac{-3x}{x - 5}$

- A) $(-\infty, \infty)$
- B) $(-\infty, 5)$
- C) $(-\infty, 0)$ or $(0, \infty)$
- D) $(-\infty, 5)$ or $(5, \infty)$

Answer: D

Given $f(x)$ and $g(x)$, find the following.

226) $f(x) = x^2 + 9x$ and $g(x) = x - 6$. Find $(f + g)(x)$ and $(f + g)(4)$.

- A) $2x^2 + 3x; 44$
- B) $x^2 + 10x - 6; 50$
- C) $x^2 + 10x - 6; 46$ D) $x^2 + 9x - 6; 46$

Answer: B

227) $f(x) = x^2 + 3x$ and $g(x) = x + 4$. Find $(f - g)(x)$ and $(f - g)(3)$.

- A) $x^2 + 2x - 4; 11$
- B) $x^2 + 3x - 4; 11$
- C) $x^2 + 2x - 4; 14$ D) $3x - 4; 5$

Answer: A

228) $f(x) = x^2 + 7x$ and $g(x) = x - 8$. Find $(fg)(4)$.

- A) -12
- B) -176
- C) -160
- D) -92

Answer: B

229) $f(x) = x^2 - 4x$ and $g(x) = x - 7$. Find $\left(\frac{f}{g}\right)(x)$ and $\left(\frac{f}{g}\right)(2)$.

A) $\frac{x^2 - 4x - 4}{x - 7}$; $\frac{4}{7}$

B) $\frac{x^2 - 4x - 2}{x - 7}$; $\frac{2}{7}$

C) $\frac{x^2 - 4x - 2}{x - 7}$; $\frac{2}{7}$

D) $\frac{x^2 - 4x - 4}{x - 7}$; $\frac{4}{5}$

Answer: D

Solve the problem.

230) Find the domain of $\frac{f}{g}$ when $f(x) = 4x^2 + 3x - 3$ and $g(x) = x - 9$.

- A) $(-\infty, -9) \cup (-9, \infty)$
- B) $\{-9\}$
- C) $\{9\}$
- D) $(-\infty, 9) \cup (9, \infty)$

Answer: D

Graph the linear function.

231) $-2x - 4y = 4$

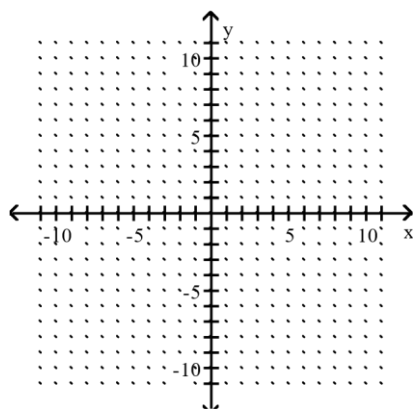

A)

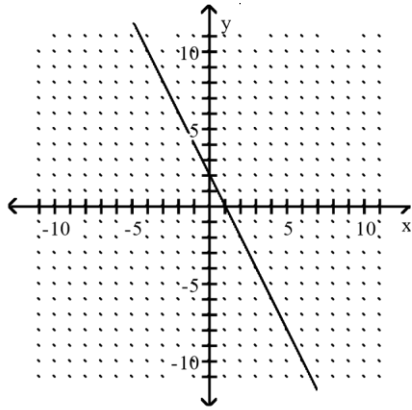

B)

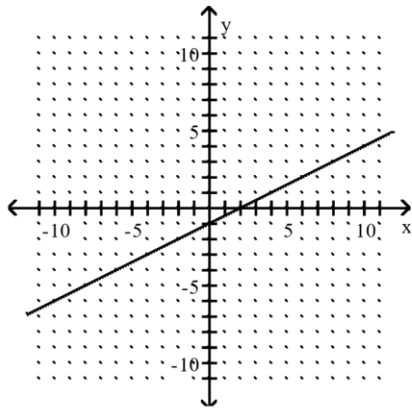

C)

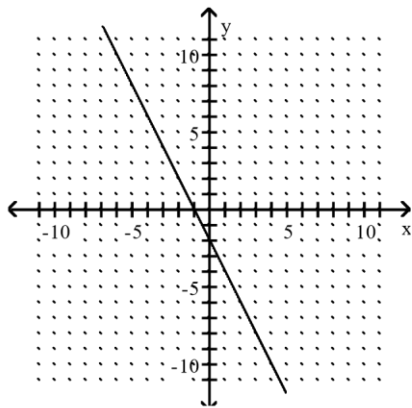

D)

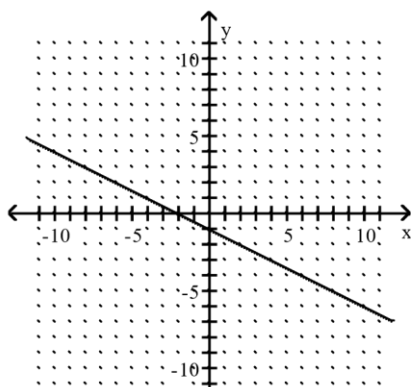

Answer: D

$\frac{2}{5}$

232) $h(x) = x - 1$

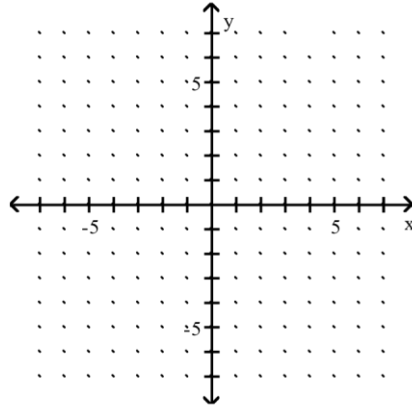

A)

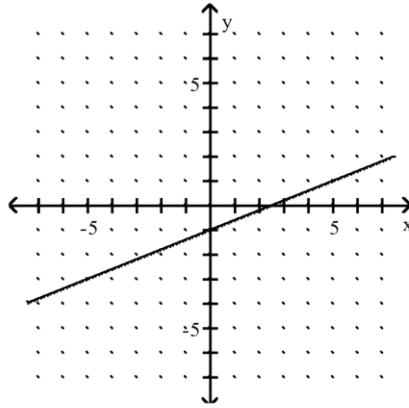

B)

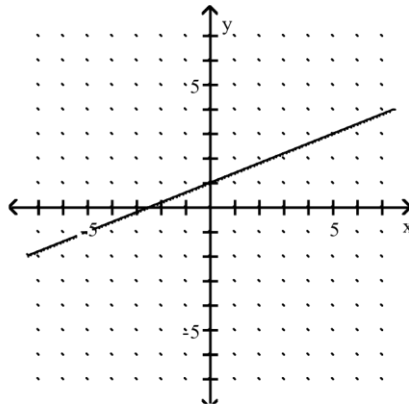

C)

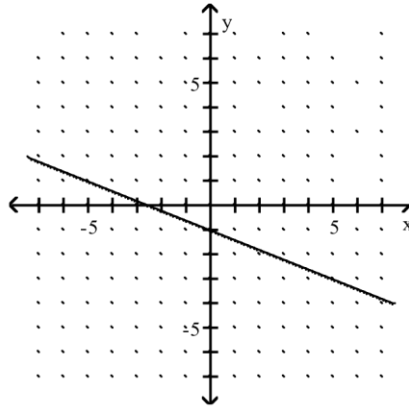

D)

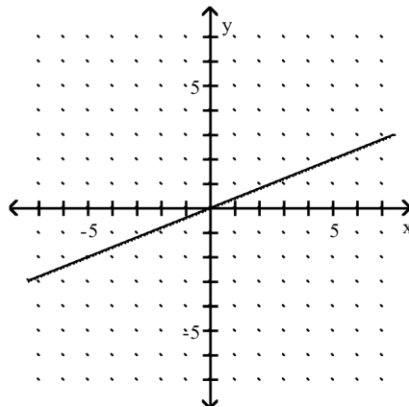

Answer: A

233) $f(x) = 5$

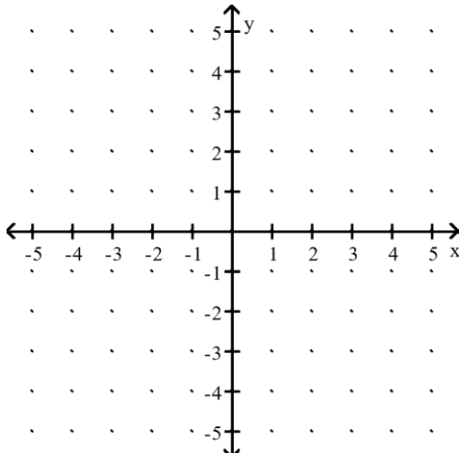

A)

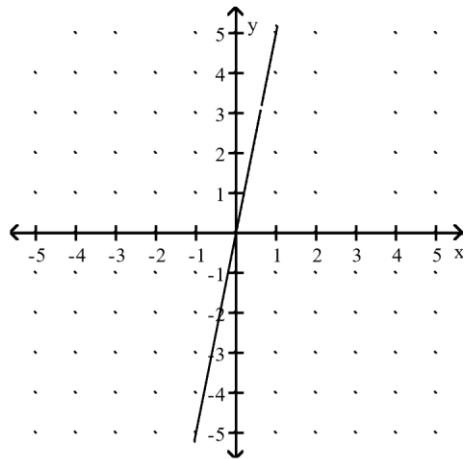

B)

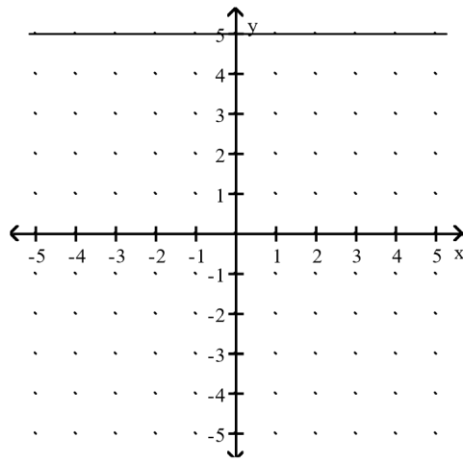

C)

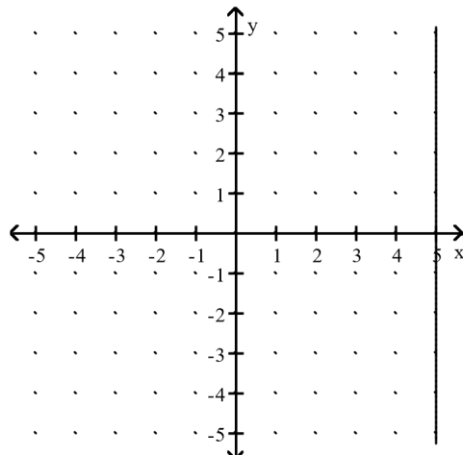

D)

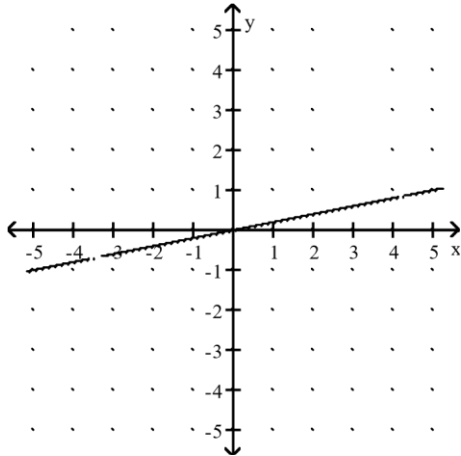

Answer: B

Find the slope of the line passing through the pair of points or state that the slope is undefined. Then indicate whether the line through the points rises, falls, is horizontal, or is vertical.

234) (3, -4) and (-5, 5)

A) $m = \frac{9}{8}$; rises

B) $m = -\frac{9}{8}$; falls

C) $m = -\frac{8}{9}$; falls

D) $m = \frac{8}{9}$; rises

Answer: B

235) (-9, 2) and (-9, 9)

A) m is undefined; vertical B) $m = -1$; falls C) $m = 1$; rises

D) $m = 0$; horizontal

Answer: A

Solve the problem.

236) The total cost in dollars for a certain company to produce x empty jars to be used by a jelly producer is given by the polynomial equation $C(x) = 0.7x + 29,000$. Find $C(80,000)$. Describe what this means in terms of the variables of the equation.

A) \$85,000; The cost of producing 80,000 jars was \$85,000.

B) \$29.70; The cost of producing 80,000 jars was \$29.70.

C) \$56,000; The cost of producing 80,000 jars was \$56,000. D) \$80,029; The cost of producing 80,000 jars was \$80,029.

Answer: A

- 237) The total cost in dollars for a certain company to produce x empty jars to be used by a jelly producer is given by the polynomial equation $C(x) = 0.2x + 17,000$. What is the slope in this model? Describe what this means in terms of rate of change.
- A) $m = 17,000$; The cost of producing jelly jars increased at a rate of 17,000 per year.
 B) $m = 0.2$; The cost of producing jelly jars increased at a rate of 0.2 per year.
 C) $m = -0.2$; The cost of producing jelly jars decreased at a rate of 0.2 per year.
 D) $m = -17,000$; The cost of producing jelly jars decreased at a rate of 17,000 per year.

Answer: B

Use the given conditions to write an equation for the line in point-slope form.

- 238) Passing through $(6, 17)$ and $(1, 7)$
- A) $f(x) = 2x + 5$
 B) $f(x) = -2x + 29$
 C) $f(x) = \frac{1}{2}x + 14$
 D) $f(x) = -\frac{1}{2}x + 20$

Answer: A

Use the given conditions to write an equation for the line in slope-intercept form.

- 239) Passing through $(2, 2)$ and perpendicular to the line whose equation is $y = 3x + 6$.
- A) $y = \frac{1}{3}x - \frac{8}{3}$ B) $y = -\frac{1}{3}x - \frac{8}{3}$
 C) $y = -\frac{1}{3}x + \frac{8}{3}$
 D) $y = -3x - 8$

Answer: C

- 240) Passing through $(2, -4)$ and parallel to the line whose equation is $8x + y = 3$.
- A) $y = -\frac{1}{8}x - \frac{3}{2}$
 B) $y = -8x + 12$ C) $y = 8x - 12$
 D) $y = -8x - 12$ Answer:

B

Solve.

- 241) A vendor has learned that, by pricing hot dogs at \$1.00, sales will reach 108 hot dogs per day. Raising the price to \$1.75 will cause the sales to fall to 69 hot dogs per day. Let y be the number of hot dogs the vendor sells at x dollars each. Find a linear equation that models the number of hot dogs sold per day when the price is x dollars each. Write the equation in slope-intercept form using function notation.
- A) $f(x) = 52x + 56$
 B) $f(x) = -52x - 160$
 C) $f(x) = -\frac{1}{52}x + \frac{5615}{52}$

$$D) f(x) = -52x + 160$$

Answer: D