

Test Bank for Mathematics in Action Algebraic Graphical and Trigonometric Problem Solving 5th Edition Consortium for Foundation Mathematics 0134134427 9780134134420

Full link download

Test Bank:

<https://testbankpack.com/p/test-bank-for-mathematics-in-action-algebraic-graphical-and-trigonometric-problem-solving-5th-edition-consortium-for-foundation-mathematics-0134134427-9780134134420/>

Solution Manual:

<https://testbankpack.com/p/solution-manual-for-mathematics-in-action-algebraic-graphical-and-trigonometric-problem-solving-5th-edition-consortium-for-foundation-mathematics-0134134427-9780134134420/>

MULTIPLE CHOICE. Choose the one alternative that best completes the statement or answers the question.

Perform the indicated operation on functions f and g .

1) If $f(x) = 5x - 4$ and $g(x) = -8x + 8$, determine $f(x) + g(x)$.

A) $-4x + 12$

B) $-3x^2 + 4$

C) $13x - 4$

D) $-3x + 4$

Answer: D

2) If $f(x) = 3x - 3$ and $g(x) = -8x + 6$, determine $f(x) - g(x)$.

A) $-5x - 3$

B) $-5x^2 + 9$

C) $11x - 9$

D) $11x + 9$

Answer: C

3) If $f(x) = x^2 + 3x - 3$ and $g(x) = -7x^2 + 10x - 3$, determine $f(x) + g(x)$.

A) $-7x^2 + 13x + 6$

B) $-8x^2 + 7x + 6$

C) $-6x^2 + 13x - 6$

D) $-6x^2 - 13x - 6$

Answer: C

4) If $f(x) = x^2 + 5x - 3$ and $g(x) = -8x^2 + 7x - 7$, determine $f(x) - g(x)$.

A) $9x^2 - 9x + 11$

B) $9x^2 - 2x + 4$

C) $-7x^2 + 12x - 4$

D) $-8x^2 - 12x + 4$

Answer: B

5) If $f(x) = x - 4$ and $g(x) = x - 3$, determine $f(2) + g(2)$.

A) 5

B) -3

C) 3

D) 11

Answer: B

6) If $f(x) = 3x^2 + 7$ and $g(x) = x - 3$, determine $f(-5) - g(-5)$.

A) 84

B) 80

C) 90

D) -77

Answer: C

7) If $f(x) = 5x + 4$ and $g(x) = 5x - 7$, determine $f(x) \cdot g(x)$.

A) $10x^2 + 14x - 28$

B) $25x^2 - 15x - 28$

C) $25x^2 - 55x + 28$

D) $5x^2 - 30x - 56$

Answer: B

8) If $f(x) = 4x + 2$ and $g(x) = x^2 + 3x - 8$, determine $f(x) \cdot g(x)$.

A) $x^2 - 7x + 6$

B) $x^3 - 14x^2 - 29x - 19$

C) $5x^3 + 16x^2 + 26x - 15$

D) $4x^3 + 14x^2 - 26x - 16$

Answer: D

9) If $f(x) = x - 3$ and $g(x) = -3x^2 + 13x - 7$, determine $f(4) \cdot g(4)$.

A) -21

B) 61

C) -385

D) -3

Answer: D

10) If $f(x) = 2x - 7$ and $g(x) = 4x + 7$, determine $5 \cdot f(x)$.

A) $20x + 35$

B) $10x - 7$

C) $20x + 7$

D) $10x - 35$

Answer: D

11) If $f(x) = 3x - 1$ and $g(x) = 4x + 9$, determine $2 \cdot g(x)$.

A) $8x + 9$

B) $6x - 2$

C) $8x + 18$

D) $6x - 1$

Answer: C

- 12) If $f(x) = x^2 + 4x - 7$ and $g(x) = 4x^2 + x - 2$, determine $3f(x) + 4g(x)$.
- A) $5x^2 + 5x - 9$ B) $19x^2 + 16x - 29$ C) $19x^4 + 16x^2 - 29$ D) $19x^2 + 5x - 9$

Answer: B

- 13) If $f(x) = x^2 + 5x - 9$ and $g(x) = 5x^2 + x + 7$, determine $4f(x) - 2g(x)$.
- A) $-6x^2 + 18x - 50$ B) $-4x^2 + 4x - 16$ C) $-6x^4 + 18x^2 - 50$ D) $-6x^2 + 4x - 16$

Answer: A

Perform the indicated operation and simplify.

- 14) $(4x - 2) + (-8x + 9)$
- A) $-4x^2 + 7$ B) $-4x + 7$ C) $12x - 7$ D) $-5x + 11$

Answer: B

- 15) $(x^2 + 3x - 4) + (-8x^2 + 8x - 4)$
- A) $-7x^2 - 11x - 8$ B) $-9x^2 + 5x + 8$ C) $-8x^2 + 11x + 8$ D) $-7x^2 + 11x - 8$

Answer: D

- 16) $(5x - 4) + (-7x^2 - 13x + 10)$
- A) $7x^2 - 2x - 14$ B) $-7x^2 - 8x + 6$ C) $-8x^2 - 8x - 6$ D) $-7x^2 + 8x + 6$

Answer: B

- 17) $(5x - 3) - (-9x + 8)$
- A) $14x + 11$ B) $14x - 11$ C) $-4x^2 + 11$ D) $-4x - 5$

Answer: B

- 18) $(x^2 + 5x - 2) - (-7x^2 + 9x - 9)$
- A) $8x^2 - 13x + 16$ B) $8x^2 - 4x + 7$ C) $-6x^2 + 14x - 7$ D) $-7x^2 - 14x + 7$

Answer: B

- 19) $(5x - 3) - (-9x^2 - 13x + 10)$
- A) $-9x^2 + 18x + 13$ B) $9x^2 - 8x - 13$ C) $9x^2 + 18x - 13$ D) $-9x^2 - 8x + 7$

Answer: C

- 20) $(6x - 3) - (3x - 2)$
- A) $-3x + 1$ B) $9x - 5$ C) $3x - 1$ D) $3x - 5$

Answer: C

- 21) $s^7 \cdot s^5 \cdot s^5$
- A) s^{17} B) s^{40} C) s^{12} D) s^{10}

Answer: A

- 22) $(-6y)(-6y^8)$
- A) $-12y^8$ B) $36y^9$ C) $6y - 6y^8$ D) $-36y^9$

Answer: B

- 23) $(4x^3)(8x^4)$
 A) $32x^7$ B) $32x^{12}$ C) $12x^{12}$ D) $12x^7$
 Answer: A
- 24) $(-2x^4)(2x^2)$
 A) $4x^8$ B) $-4x^8$ C) $-4x^6$ D) $4x^6$
 Answer: C
- 25) $(-6x^4)(-9x^4)$
 A) $-54x^{16}$ B) $-15x^{16}$ C) $54x^8$ D) $-15x^8$
 Answer: C
- 26) $(3m^4z^4)(4m^4z^2)$
 A) $12m^8z$ B) $12mz^8$ C) $12m^8z^6$ D) $12mz^6$
 Answer: C
- 27) $(-2m^2z^4)(4m^2z^2)$
 A) $-8mz^6$ B) $-8mz^4$ C) $-8m^4z^6$ D) $-8m^6z^4$
 Answer: C
- 28) $(-2x^4y^4)(-4x^4y^2)$
 A) $8xy^8$ B) $8x^8y^6$ C) $8xy^6$ D) $8x^6y^8$
 Answer: B
- 29) $(8x^2z)(-3yz)(-3xy^2z^5)$
 A) $72x^3y^3z^7$ B) $72x^3y^3z^6$ C) $72x^3y^4z^6$ D) $-72x^2y^3z^7$
 Answer: A
- 30) $(-4p^4r)(4p^2qr^3)(-3q^3r^4)$
 A) $-48p^6q^4r^8$ B) $48p^5q^5r^8$ C) $48p^6q^4r^8$ D) $-48p^5q^5r^8$
 Answer: C
- 31) $(4x + 4)(x - 12)$
 A) $x^2 - 48x - 44$ B) $4x^2 - 45x - 48$ C) $x^2 - 44x - 45$ D) $4x^2 - 44x - 48$
 Answer: D
- 32) $(-2 + x)(3x + 1)$
 A) $3x^2 - 6x - 2$ B) $x^2 - 5x - 5$ C) $3x^2 - 5x - 2$ D) $3x^2 - 2x - 5$
 Answer: C
- 33) $(x + 9)(2x + 7)$
 A) $2x^2 + 63x + 25$ B) $2x^2 + 23x + 63$ C) $2x^2 + 25x + 63$ D) $2x^2 + 25x + 25$
 Answer: C

34) $(x + 4)(x^2 - x + 9)$

A) $x^3 + 36$

B) $x^3 + 3x^2 + 36$

C) $x^3 + 3x^2 + 5x + 36$

D) $x^3 + 5x^2 + 13x + 36$

Answer: C

35) $(x - 3)(9x^2 + x + 8)$

A) $9x^3 - 28x^2 + 5x - 24$

B) $9x^3 + 26x^2 + 5x - 24$

C) $9x^3 - 26x^2 + 11x - 24$

D) $9x^3 - 26x^2 + 5x - 24$

Answer: D

36) $3(4x - 3) - 6(8x - 7)$

A) $36x - 33$

B) $-36x - 33$

C) $-36x + 33$

D) $-36x - 4$

Answer: C

37) $7(8x - 7) - 4(2x - 4)$

A) $64x + 33$

B) $48x + 33$

C) $48x - 33$

D) $64x - 33$

Answer: C

38) $(3x + 11)(3x - 11)$

A) $3x^2 - 66x - 121$

B) $9x^2 - 121$

C) $9x^2 - 66x - 121$

D) $9x^2 + 66x - 121$

Answer: B

39) $(4x - 5)^2$

A) $16x^2 - 40x + 25$

B) $16x^2 + 25$

C) $4x^2 + 25$

D) $4x^2 - 40x + 25$

Answer: A

40) $(5x + 3)^3$

A) $25x^6 + 15x^3 + 729$

B) $125x^3 + 225x^2 + 135x + 27$

C) $25x^2 + 30x + 9$

D) $125x^3 + 225x^2 + 225x + 27$

Answer: B

Use the properties of exponents to simplify the expression, where $x \neq 0$. Write the answer with positive exponents only.

41) $\frac{42x^7}{7x^5}$

A) $35x^2$

B) $6x^{1.4}$

C) $6x^{12}$

D) $6x^2$

Answer: D

42) $\frac{m^8n^6}{m^3n^3}$

A) m^3n^2

B) $m^{11}n^9$

C) $(mn)^8$

D) m^5n^3

Answer: D

$$43) \frac{50x^{10}y^7}{10x^6y}$$

A) $5x^4y^7$

B) $5x^4y^6$

C) $5x^2y^7$

D) $40x^4y^7$

Answer: B

$$44) \frac{-8x^7y^5}{2x^5y^2}$$

A) $4x^2y^3$

B) $-10x^2y^3$

C) $-4x^{\frac{7}{5}}y^{\frac{5}{2}}$

D) $-4x^2y^3$

Answer: D

$$45) \frac{24x^7y^6}{-8x^3y^4}$$

A) $3x^4y^2$

B) $32x^4y^2$

C) $-3x^{\frac{7}{3}}y^{\frac{3}{2}}$

D) $-3x^4y^2$

Answer: D

$$46) \frac{-4x^7y^8}{-2x^4y^6}$$

A) $-6x^3y^6$

B) $-2x^3y^2$

C) $-2x^{\frac{7}{4}}y^{\frac{4}{3}}$

D) $2x^3y^2$

Answer: D

$$47) (-3)^{-2}$$

A) 9

B) -9

C) $\frac{1}{-9}$

D) $\frac{1}{9}$

Answer: D

$$48) (-5)^{-1}$$

A) -5

B) $\frac{1}{5}$

C) 5

D) $-\frac{1}{5}$

Answer: D

$$49) (5x)^{-2}$$

A) -10x

B) $\frac{-10}{x^2}$

C) $25x^2$

D) $\frac{1}{25x^2}$

Answer: D

$$50) x^{-6}$$

A) $\frac{1}{x^6}$

B) $-x^6$

C) x^6

D) $\frac{6}{x}$

Answer: A

Simplify the following by applying the appropriate properties of exponents.

51) $(x^5)^6$

A) $\frac{1}{x^{11}}$

B) $\frac{1}{x^{30}}$

C) x^{11}

D) x^{30}

Answer: D

52) $(xy^7)^3$

A) xy^{21}

B) x^3y^{10}

C) xy^{10}

D) x^3y^{21}

Answer: D

53) $3(x^6y^8)^5$

A) $3x^6y^{40}$

B) $243x^{30}y^{40}$

C) $3x^{11}y^{13}$

D) $3x^{30}y^{40}$

Answer: D

54) $(-3)^4$

A) -12

B) 12

C) -81

D) 81

Answer: D

55) -5^2

A) -32

B) 25

C) -10

D) -25

Answer: D

56) $16^{3/4}$

A) 8

B) $\sqrt[3]{8}$

C) 11

D) 64

Answer: A

57) $27^{4/3}$

A) 243

B) 729

C) 2187

D) 81

Answer: D

58) $(-27)^{1/3}$

A) 3

B) -27

C) -3

D) Not a real number

Answer: C

59) $-\left(\frac{49}{36}\right)^{1/2}$

A) $\frac{6}{7}$

B) $-\frac{7}{6}$

C) Not a real number

D) $-\frac{49}{72}$

Answer: B

60) $(x^{10}y^5)^{1/5}$

A) $x^{10}y$

B) x^2

C) $x^2|y|$

D) x^2y

Answer: D

Solve the problem.

- 61) It has been projected that in twenty years the world population of a specific fish will be 413,600,000. Write scientific notation for the world population of this fish.

A) 4.136×10^8 B) 4.136×10^7 C) 4.136×10^9 D) 41.36×10^9

Answer: A

- 62) The average discharge at the mouth of a river is 5.4×10^7 cubic feet per second. Convert the number to decimal notation.

A) 5,400,000,000 ft³ B) 5,400,000 ft³ C) 540,000,000 ft³ D) 54,000,000 ft³

Answer: D

- 63) A real estate investor needs to determine how many acres a piece of property is. One square foot is equivalent to 0.0000229568 acres. If the property measures approximately 34,000 square feet, how many acres is this? Round the answer to two decimal places whenever necessary.

A) 0.78 acre B) 1.01 acre C) 0.08 acre D) 7.81 acres

Answer: A

- 64) The mean radius of Planet X is 13,958 kilometers. The formula for determining the volume of a sphere, V , is $V = \frac{4}{3}\pi r^3$. Determine the approximate volume, in cubic kilometers, of Planet X. Use $\pi \approx 3.14159$. Express the answer in scientific notation rounded to four decimal places.

A) 1.1391×10^{13} cu. km B) 8.1608×10^8 cu. km
C) 2.5977×10^8 cu. km D) 3.6258×10^{12} cu. km

Answer: A

- 65) The national debt of a small country is \$7,250,000,000 and the population is 2,519,000. What is the amount of debt per person?

A) $\$2.88 \times 10^3$ B) \$28.80 C) $\$2.88 \times 10^6$ D) \$2.88

Answer: A

- 66) The national debt of a country is \$42,660,000,000 and the population is 4,740,000. What is the debt per person? Write answer without exponents.

A) \$90,000 B) \$202,208,400 C) \$9000 D) \$900

Answer: C

- 67) A salesperson earned \$325 a week plus a bonus of \$17 for each service contract sold. If the pay one week was \$461 how many service contracts were sold?

A) 5 B) 19 C) 2 D) 8

Answer: D

- 68) The cost of tuition at Johnson Community College is \$190 per credit hour. Each student also has to pay \$50 in fees. Model the cost C for x credit hours taken.

A) $C(x) = 190 + 50x$ B) $C(x) = 190x$ C) $C(x) = 50x$ D) $C(x) = 190x + 50$

Answer: D

69) A volatile stock began the final week of the year worth x dollars per share. Then, during the course of trading that week, the stock's value doubled, lost 5 points, gained 16 points, lost 7 points, and finally lost half its value to close the year. Express, in symbolic form, the total value of your stock at the end of the year if you own 80 shares.

- A) $(x + 2)$ B) $80(x + 4)$ C) $80(2x + 2)$ D) $80(x + 2)$

Answer: D

70) Suppose that the average monthly cost c (in dollars) of cable TV per subscription in the United States can be modeled by the equation $c = 1.5t + 30.5$ and that the number of cable subscribers n (in millions) can be modeled by $n = -0.8t + 65.7$, where t is the number of years since 2000. Determine the total monthly cost of cable TV in 2003.

- A) $-\$8,132,250,000$ B) $\$1,993,050,000$ C) $\$4,777,500,000$ D) $\$2,215,500,000$

Answer: D

71) Suppose that the annual consumption c (in gallons per person) of sports drinks in the United States can be modeled by the equation $c = 0.12t + 0.6$ and that the U.S. population p (in millions) can be modeled by $p = 3.3t + 250$, where t is the number of years since 1990. Determine the total annual consumption of sports drinks in the U.S. in 1994.

- A) 154,656,000 gal B) 275,702,400 gal C) 156,336,000 gal D) 284,256,000 gal

Answer: D

72) A planning committee has determined the revenue obtained from ticket sales for a banquet is modeled by the function $R(t) = -0.5t^2 + 30t + 200$. Use a graphing calculator to determine the maximum revenue that can be obtained, and the total number of tickets that must be sold to obtain this maximum revenue.

- A) $\$650.00$; 30 tickets B) $\$649.50$; 29 tickets C) $\$649.50$; 31 tickets D) $\$1550.00$; 30 tickets

Answer: A

73) In one report, the number n (in thousands) of people who earned a bachelor's degree in the sciences was modeled by the system

$$W(t) = 3.3t + 112.7 \quad \text{for women}$$

$$M(t) = 1.4t + 122.4 \quad \text{for men}$$

where t is the number of years since 1980. Find an expression for the total number (in thousands) of people, women and men, who earned a bachelor's degree in the sciences t years after 1980.

- A) $4.62t + 235.1$ B) $9.4t + 235.1$ C) $4.7t + 235.1$ D) $116t + 123.8$

Answer: C

74) You have planned to put in a rectangular patio that measures 6 feet by 9 feet. However, you neglected to include enough seating room around your patio table. Let x be the number of additional feet you will extend the length and the width of the patio. Determine a formula for the area of the extended patio. If x is 3 feet, by how much have you increased the area of the patio from the original plan?

- A) $54 + x^2$; 9 ft B) $54 + x^2$; 63 ft
C) $54 + 15x + x^2$; 108 ft D) $54 + 15x + x^2$; 54 ft

Answer: D

Find the requested composition of functions.

75) Given $f(x) = 4x + 8$ and $g(x) = 4x - 1$, determine $f(g(x))$.

- A) $16x + 31$ B) $16x + 4$ C) $16x + 12$ D) $16x + 7$

Answer: B

76) Given $f(x) = -4x + 7$ and $g(x) = 3x + 7$, determine $g(f(x))$.

A) $-12x + 28$

B) $-12x - 14$

C) $12x + 28$

D) $-12x + 35$

Answer: A

77) Given $f(x) = 4x^2 + 3x + 6$ and $g(x) = 3x - 5$, determine $g(f(x))$.

A) $12x^2 + 9x + 23$

B) $4x^2 + 3x + 1$

C) $4x^2 + 9x + 13$

D) $12x^2 + 9x + 13$

Answer: D

78) Given $f(x) = 7x - 1$ and $g(x) = 2x^2 - 8x + 5$, determine $g(f(9))$.

A) -344

B) 7197

C) -367

D) 664

Answer: B

79) Given $f(x) = x^2 + 5$ and $g(x) = x^2 - 5$, determine $f(g(x))$.

A) $x^4 - 10x^2 + 20$

B) $x^4 + 10x^2 + 30$

C) $x^4 - 10x^2 + 30$

D) $x^4 + 10x^2 + 20$

Answer: C

80) Given $f(x) = -5x - 7$ and $g(x) = -3x^2 + 6x - 9$, determine $g(f(-4))$.

A) 30

B) 98

C) 398

D) -438

Answer: D

81) Given $f(x) = -4x^2$ and $g(x) = 3x^3$, determine $f(g(x))$.

A) $-192x^6$

B) $-36x^5$

C) $-36x^6$

D) $-12x^5$

Answer: C

82) Given $f(x) = -3x^2$ and $g(x) = 3x^3$, determine $g(f(x))$.

A) $-9x^5$

B) $-27x^5$

C) $-81x^6$

D) $-27x^6$

Answer: C

83) Given $f(x) = 5x^2$ and $g(x) = -4x^3$, determine $f(g(-4))$.

A) $-81,920$

B) $20,480$

C) $327,680$

D) $-2,048,000$

Answer: C

84) Given $p(x) = \frac{1}{x}$ and $c(x) = x + 9$, determine $p(c(x))$.

A) $\frac{1}{x+9}$

$\frac{1}{x + \frac{1}{9}}$

$\frac{1}{\frac{1}{x} + 9}$

Answer: A

B)

C)

D)

x

+

9

Evaluate the expression using the values given in the table.

85) $f(g(6))$

x	1	5	11	12
f(x)	-3	11	1	14

x	-5	-3	1	6
g(x)	1	-8	5	11

A) 1

B) Undefined

C) 11

D) 5

Answer: A

86) $g(f(1))$

x	1	5	9	12
f(x)	-1	9	3	15

x	-5	-1	1	3
g(x)	1	-7	5	9

A) -1

B) -7

C) 9

D) 5

Answer: B

Given $f(x)$, find $f^{-1}(x)$.

87) $f(x)$ defined by the set of ordered pairs $\{(-3, 6), (3, -6), (1, -4), (-1, 4)\}$

A) No inverse exists.

B) $\{(6, -3), (-6, 3), (-4, 3), (4, -1)\}$

C) $\{(6, -3), (-6, 3), (-4, 1), (4, -1)\}$

D) $\{(6, -3), (-3, 3), (-4, 1), (4, -1)\}$

Answer: C

88) $f(x) = 6x + 3$

A) $\frac{x+3}{6}$

B) $\frac{x-3}{6}$

C) $\frac{x}{6} - 3$

D) No inverse exists.

Answer: B

89) $f(x) = \frac{3}{x+7}$

A) $\frac{x}{7+3x}$

B) $\frac{-7x+3}{x}$

C) $\frac{7+3x}{x}$

D) No inverse exists.

Answer: B

Graph the function as a solid line and its inverse as a dashed line on the same set of axes.

90) $f(x) = 4x$

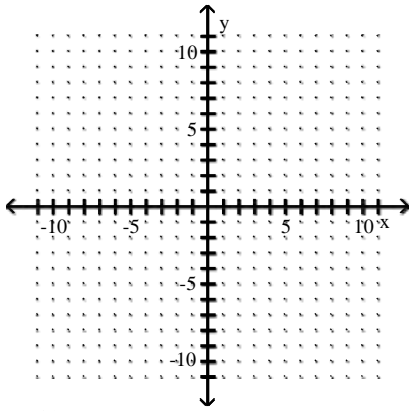

A)

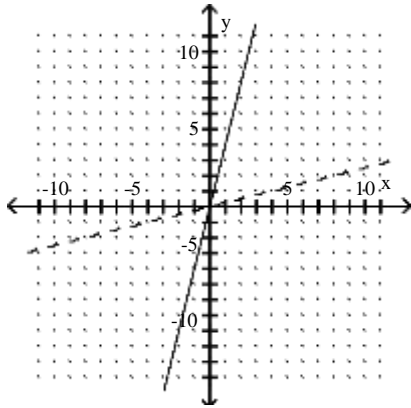

C)

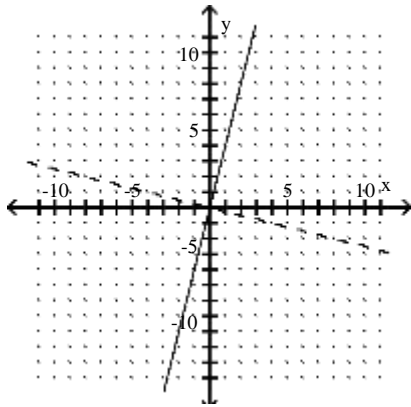

B)

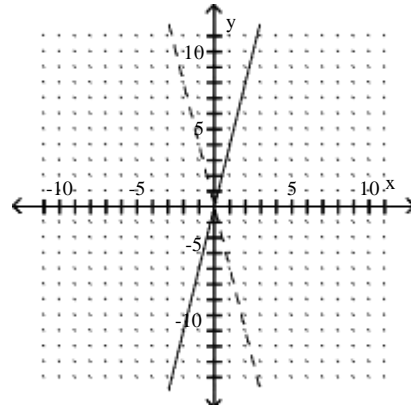

D)

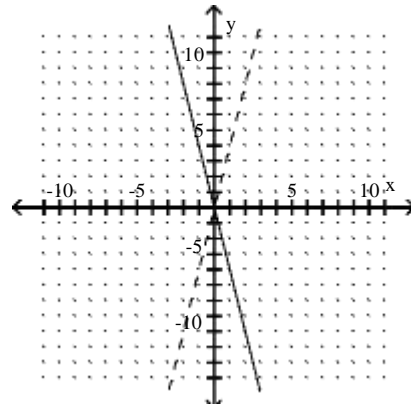

Answer: A

91) $f(x) = -6x$

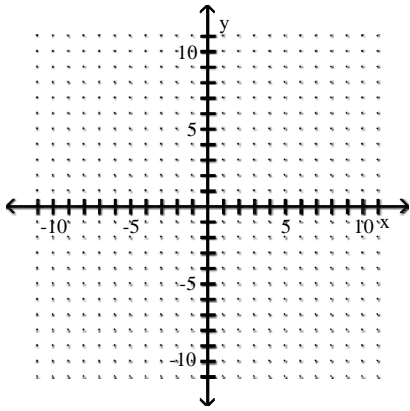

A)

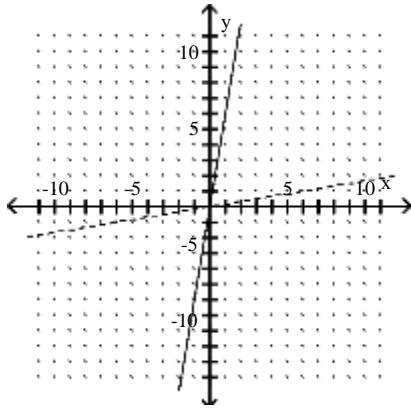

C)

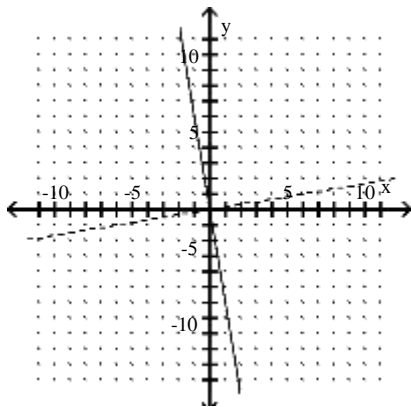

B)

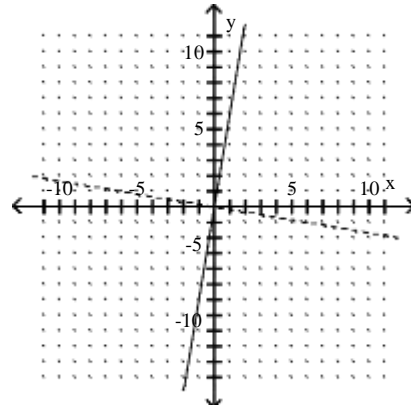

D)

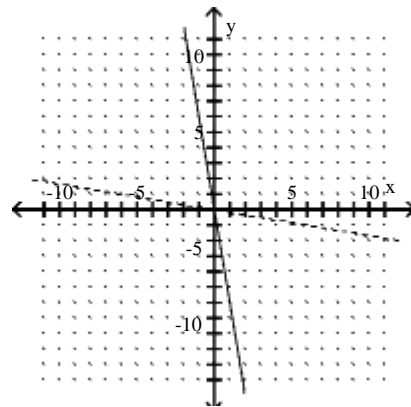

Answer: D

92) $f(x) = -3x + 8$

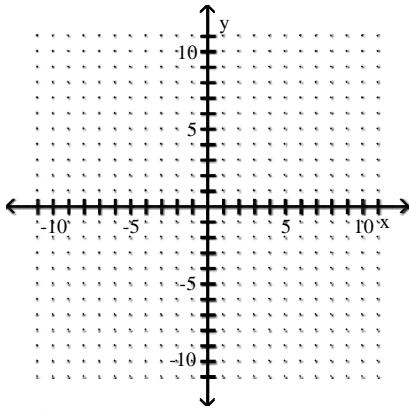

A)

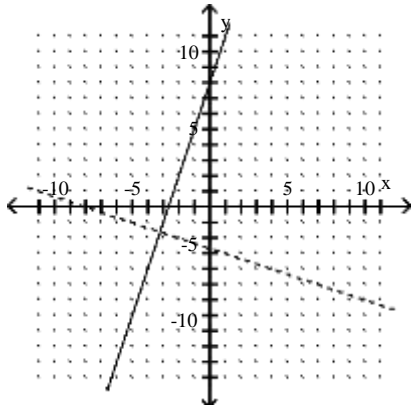

C)

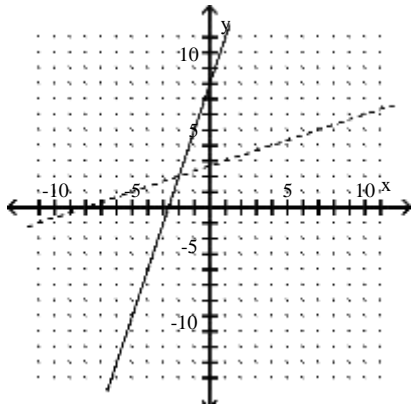

B)

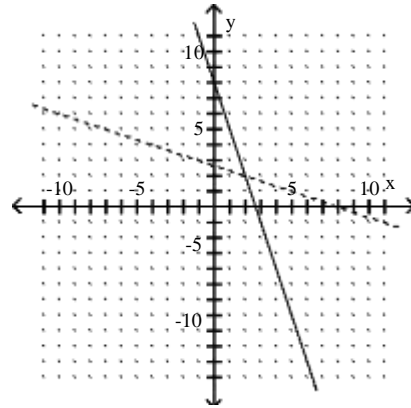

D)

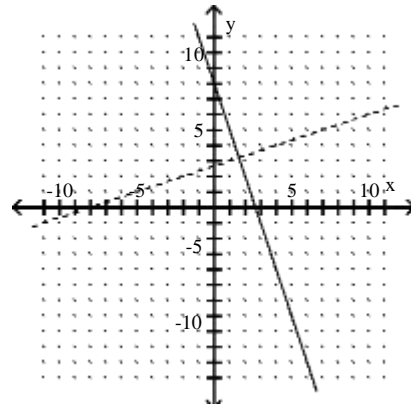

Answer: B

Solve the problem.

93) An organization determines that the cost per person of chartering a bus is given by the formula

$$C(x) = \frac{250 + 6x}{x},$$

where x is the number of people in the group and $C(x)$ is in dollars. Find a formula for $C^{-1}(x)$.

A) $C^{-1}(x) = \frac{6}{x - 250}$

B) $C^{-1}(x) = \frac{250}{x - 6}$

C) $C^{-1}(x) = \frac{250}{x + 6}$

D) $C^{-1}(x) = \frac{250 + x}{6}$

Answer: B

94) To remodel a bathroom, a contractor charges \$30 per hour plus material costs, which amount to \$4500. Therefore, the total cost to remodel the bathroom is given by $f(x) = 30x + 4500$ where x is the number of hours the contractor works. Find a formula for $f^{-1}(x)$. What does $f^{-1}(x)$ compute?

- A) $f^{-1}(x) = \frac{x}{30} - 4500$; This computes the number of hours worked if the total cost is x dollars.
 B) $f^{-1}(x) = \frac{x}{30} - 150$; This computes the number of hours worked if the total cost is x dollars.
 C) $f^{-1}(x) = \frac{x}{30} - 4500$; This computes the total cost if the contractor works x hours.
 D) $f^{-1}(x) = \frac{x}{30} - 150$; This computes the total cost if the contractor works x hours.

Answer: B

95) The population of public schools in a certain region can be modeled by the function $f(x) = 0.8x + 33$, where x represents the years after 2000 and $f(x)$ represents the student population in thousands. Determine the inverse function and predict the year in which the school population will be 40 thousand.

- A) $f^{-1}(x) = \frac{x}{0.8} - 33$; 2017
 B) $f^{-1}(x) = \frac{x-33}{0.8}$; 2009
 C) $f^{-1}(x) = \frac{x+33}{0.8}$; 2091
 D) $f^{-1}(x) = \frac{x}{0.8} + 33$; 2083

Answer: B

96) An student from India is coming to the United States as an exchange student. The student has saved up 90,000 Indian rupees. The student is making a stop in England on the way and will need to convert his money to British pounds using the function $f(x) = 0.01248x$. When he gets to the United States he will need to convert his British pounds to U.S. Dollars using the function $g(p) = 1.9849x$. If the student does not make the stop in England, but flies directly to the United States, write a new function that would tell how much his 90,000 Indian rupees would be in U.S. dollars and evaluate. (Hint: Determine $g(f(x))$.)

- A) $g(f(x)) = 0.02477155x$; \$2229.43968
 B) $g(f(x)) = 1.99738x$; \$179,764.2
 C) $g(f(x)) = 1.99738x$; \$1,797,642
 D) $g(f(x)) = 0.02477155x$; \$222.943968

Answer: A

97) An oil well off the Gulf Coast is leaking, with the leak spreading oil over the surface of the gulf as a circle. At any time t , in minutes, after the beginning of the leak, the radius of the oil slick on the surface is $r(t) = 6t$ ft. Find the area A of the oil slick as a function of time. (Hint: $A(r) = \pi r^2$ gives the area of a circle.)

- A) $A(r(t)) = 6\pi t^2$
 B) $A(r(t)) = 36\pi t^2$
 C) $A(r(t)) = 36\pi t$
 D) $A(r(t)) = 36t^2$

Answer: B