

Test Bank for Mathematics with Applications In the  
Management Natural and Social Sciences 11th Edition Lial  
Hungerford Holcomb Mullins 9780321931078

Full link download

Test Bank:

<https://testbankpack.com/p/solution-manual-for-mathematics-with-applications-in-the-management-natural-and-social-sciences-11th-edition-lial-hungerford-holcomb-mullins-9780321931078/>

Solution Manual:

<https://testbankpack.com/p/test-bank-for-mathematics-with-applications-in-the-management-natural-and-social-sciences-11th-edition-lial-hungerford-holcomb-mullins-9780321931078/>

CHAPTER 2 FORM A

Name \_\_\_\_\_

Determine whether the given ordered pair is a solution of the given equation.

1)  $3x + y = 13$ ; (3, 4)

A) Yes

B) No

Graph the linear equation.

2)  $-x = -2y - 6$

A)

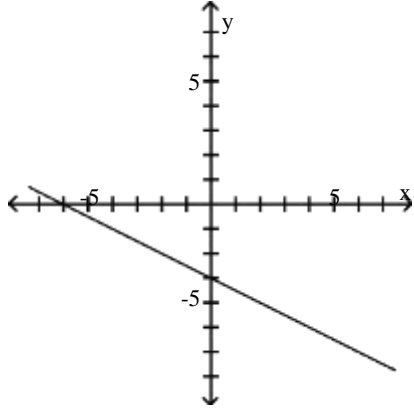

B)

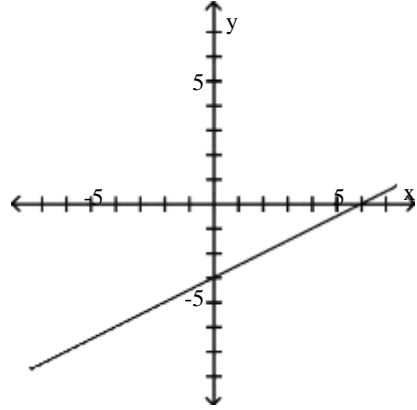

C)

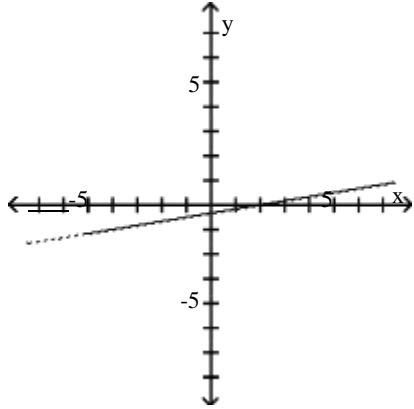

D)

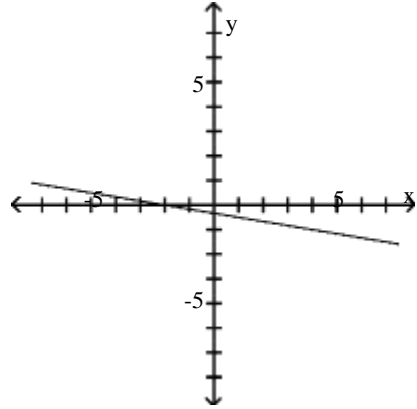

Give the x-intercepts and y-intercepts of the graph.

3)

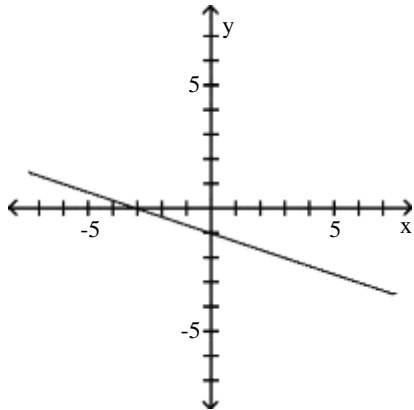

- A) x-intercept: -1; y-intercept: -3
- C) x-intercept: 1; y-intercept: 3

- B) x-intercept: 3; y-intercept: 1
- D) x-intercept: -3; y-intercept: -1

Find the x-intercepts and y-intercepts of the graph of the equation.

4)  $3x + y = 6$

- A) x-intercept: -6; y-intercept: 4
- C) x-intercept: 2; y-intercept: 6

- B) x-intercept: 4; y-intercept: -6
- D) x-intercept: 6; y-intercept: 2

Solve the problem.

- 5) The height  $h$  in meters of an object thrown upward from the roof of a building after time  $t$  seconds is shown in the graph below. Approximately how high will the object be after 4 seconds?

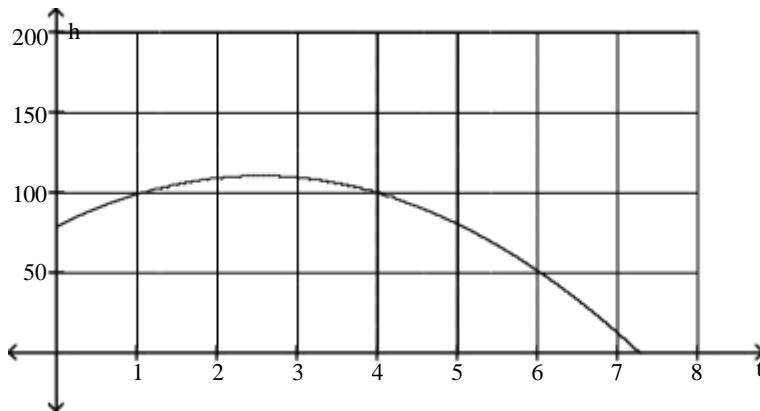

- A) 100 m
- B) 75 m
- C) 50 m
- D) 0m

Sketch the graph of the equation.

6)  $y = \sqrt{x+5}$

A)

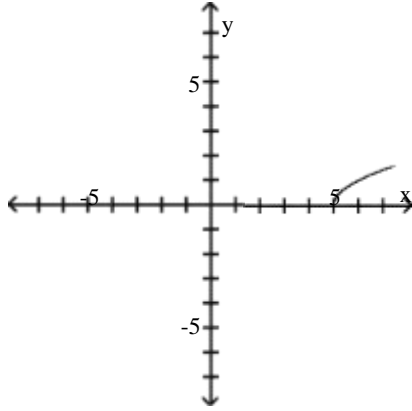

B)

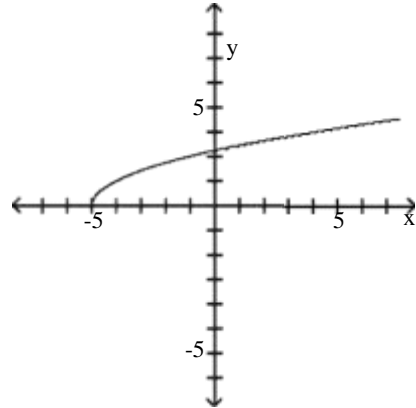

C)

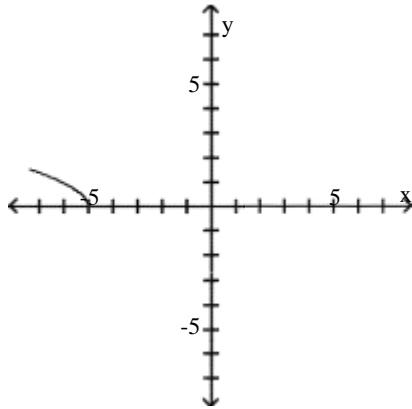

D)

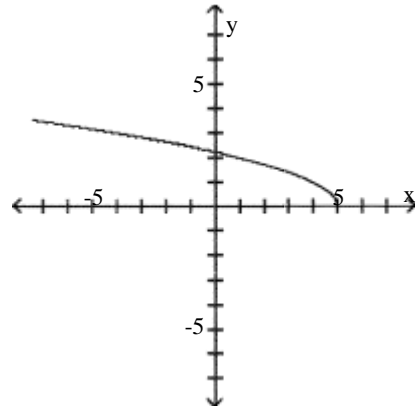

Use a graphing calculator to approximate all real solutions of the equation  $f(x) = 0$ .

7)  $f(x) = x^3 - 4x^2 - 49x + 196$

A) 4

B) -7, 4, 7

C) 49, 4, 196

D) -4, 4, 7

Find the slope of the line, if it is defined.

8) Through the origin and  $(-5, -5)$

A) 1

B) 5

C) -5

D) -1

Find the slope and the y-intercept of the line.

9)  $3x + 4y = 14$

A)  $m = \frac{3}{4}$ ;  $b = 14$

B)  $m = \frac{4}{3}$ ;  $b = \frac{7}{2}$

C)  $m = -\frac{4}{3}$ ;  $b = 4$

D)  $m = -\frac{3}{4}$ ;  $b = \frac{7}{2}$

Identify whether the slope is positive, negative, zero, or undefined.

10)

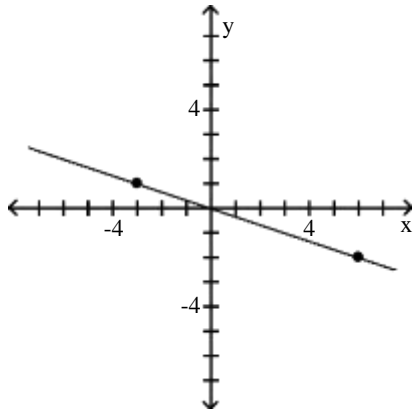

A) Positive

B) Negative

C) Zero

D) Undefined

Choose one of the four lines graphed which most closely resembles the graph of the given equation.

11)  $y = 5x + 6$

A)

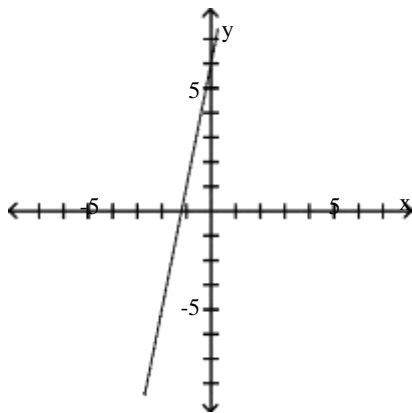

B)

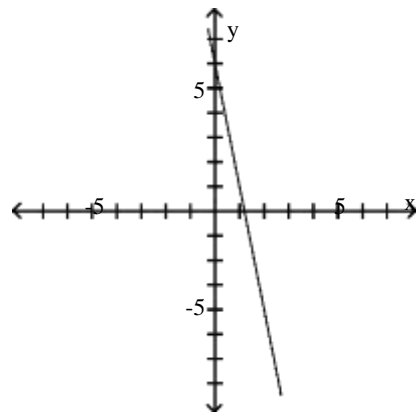

C)

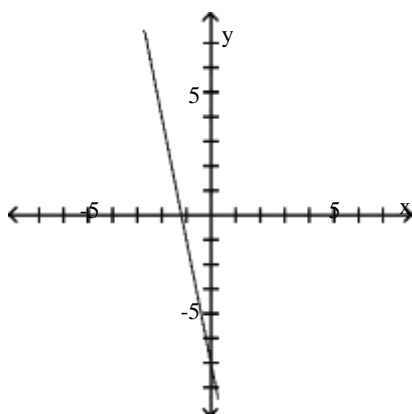

D)

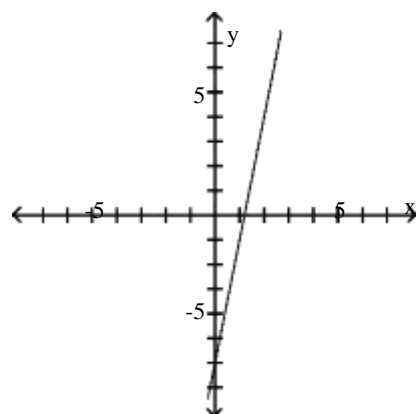

Decide whether the pair of lines is parallel, perpendicular, or neither.

12)  $12x + 4y = 16$   
 $24x - 8y = 32$

A) Parallel

B) Perpendicular

C) Neither

Write an equation in standard form for a line passing through the pair of points.

13)  $(-8, 1)$  and  $(0, -6)$

A)  $-7x - 8y = 48$

B)  $7x - 8y = 48$

C)  $-9x + 6y = -36$

D)  $9x - 6y = -36$

Find an equation of the the line satisfying the given conditions.

14) Through  $(-2, 4)$ ; parallel to  $-3x + 4y = 9$

A)  $-3x + 4y = -22$

B)  $4x + 3y = 22$

C)  $-3x + 4y = 22$

D)  $4x + 3y = 4$

Solve the problem.

15) In one U.S. town the annual consumption,  $b$ , of beef (in kg per person) can be estimated by  $b = -\frac{1}{3}t + 21$ , where  $t$  is the number of years since 1975. Estimate the beef consumption in the year 1995.

A) About 11 kg per person

B) About 14 kg per person

C) About 28 kg per person

D) About 8 kg per person

16) In a lab experiment 16 grams of acid were produced in 19 minutes and 20 grams of acid were produced in 36 minutes. Let  $y$  be the grams produced in  $x$  minutes. Write an equation for grams produced.

A)  $-4x + 17y = 259$

B)  $4x + 17y = 348$

C)  $-4x + 17y = 196$

D)  $4x + 17y = 484$

17) The information in the chart below gives the salary of a person for the stated years. Model the data with a linear function using the points  $(1, 46,000)$  and  $(3, 53,000)$ . Then use this function to predict the salary for the year 2011.

x	Year	Salary
0	2000	\$ 43,000
1	2001	\$ 46,000
2	2002	\$ 50,000
3	2003	\$ 53,000
4	2004	\$ 57,000

A) \$ 88,000

B) \$ 74,000

C) \$ 81,000

D) \$ 67,000

18) In order for a chemical reaction to take place, the Fahrenheit temperature of the reagents must be at least 144.65°F. Find the Celsius temperatures at which the reaction may occur. ( $F = \frac{9}{5}C + 32$ )

A)  $C \geq 292.37^\circ$

B)  $C \leq 62.58^\circ$

C)  $C \geq 62.58^\circ$

D)  $C < 292.37^\circ$

Solve the inequality.

19) Soylent Office Supplies rents photocopiers for a monthly charge of \$160 plus 10 cents per copy. Globex Business Supplies rents photocopiers for a monthly charge of \$360 plus 5 cents per copy. What is the number of copies above which Soylent's charges are the higher of the two?

A) 3,000 copies

B) 6,000 copies

C) 4,000 copies

D) 10,000 copies

20)  $(c + 7)(c + 3)(c + 2) > 0$

A)  $(-\infty, -7)$  or  $(-3, -2)$

B)  $(-7, -3)$  or  $(-2, \infty)$

C)  $(-2, \infty)$

D)  $(-\infty, -3)$

## Answer Key

Testname: CHAPTER 2 FORM A

- 1) A
- 2) B
- 3) D
- 4) C
- 5) A
- 6) B
- 7) B
- 8) A
- 9) D
- 10) B
- 11) A
- 12) C
- 13) A
- 14) C
- 15) B
- 16) C
- 17) C
- 18) C
- 19) C
- 20) B



# CHAPTER 2 FORM B

Name \_\_\_\_\_

Determine whether the given ordered pair is a solution of the given equation.

1)  $(x - 6)^2 + (y + 3)^2 = 5$ ; (4, -4)

A) Yes

B) No

Graph the linear equation.

2)  $8x + 16y = 32$

A)

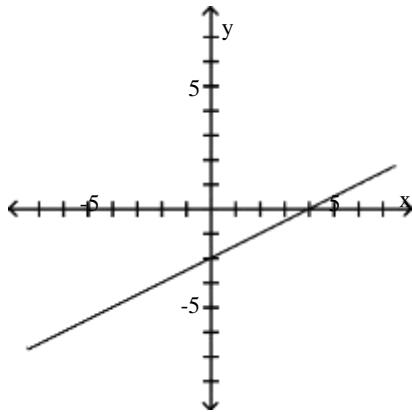

B)

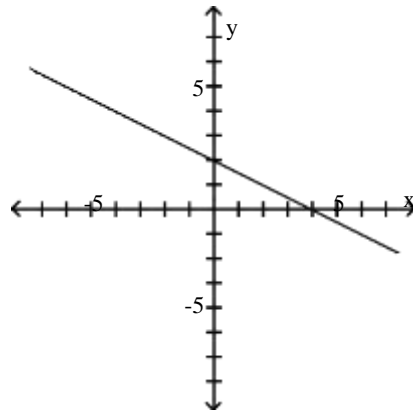

C)

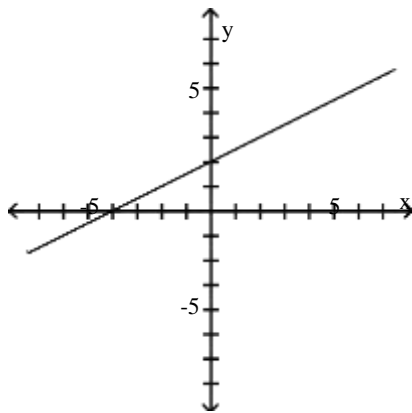

D)

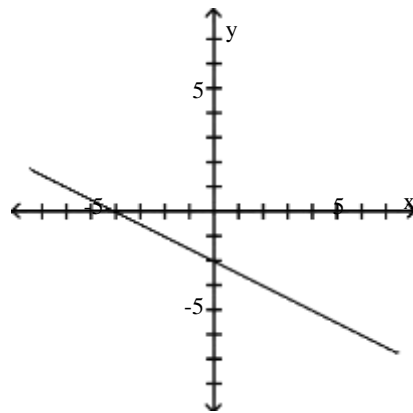

Give the x-intercepts and y-intercepts of the graph.

3)

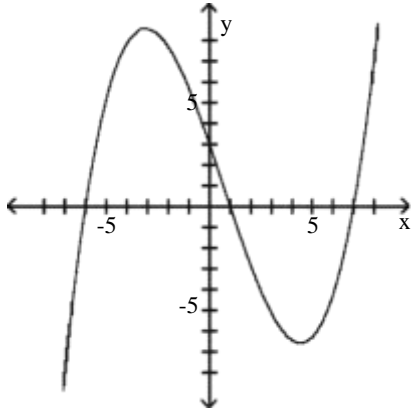

- A) x-intercepts: -6, 1, 7; y-intercept: 3  
C) x-intercepts: -6, 7; y-intercept: 3

- B) x-intercept: 3; y-intercepts: -6, 1, 7  
D) x-intercept: 3; y-intercepts: -6, 7

Find the x-intercepts and y-intercepts of the graph of the equation.

4)  $y = x^2 - 3$

- A) x-intercept(s):  $(\sqrt{3}, 0)$  and  $(-\sqrt{3}, 0)$ , y-intercept:  $(0, 3)$   
B) x-intercept(s):  $(0, \sqrt{3})$  and  $(0, -\sqrt{3})$ , y-intercept:  $(0, -3)$   
C) x-intercept(s):  $(\sqrt{3}, 0)$  and  $(-\sqrt{3}, 0)$ , y-intercept:  $(0, -3)$   
D) x-intercept(s):  $(\sqrt{0}, 0)$ , y-intercept:  $(0, -3)$

Identify the graph of the function.

5)  $f(x) = (x + 3)^3 - 2$

A)

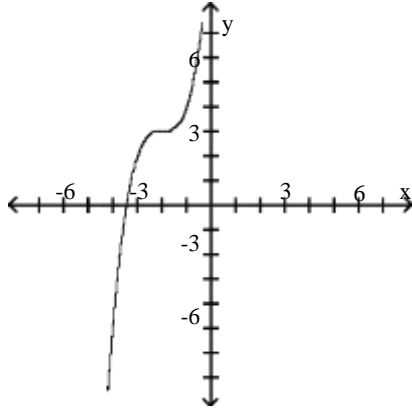

B)

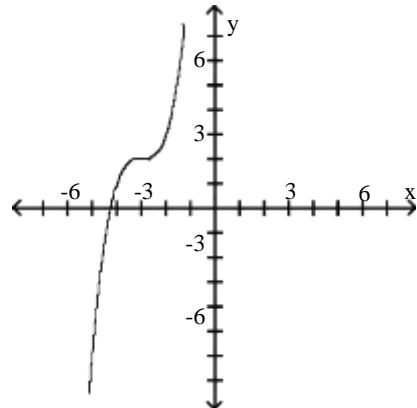

C)

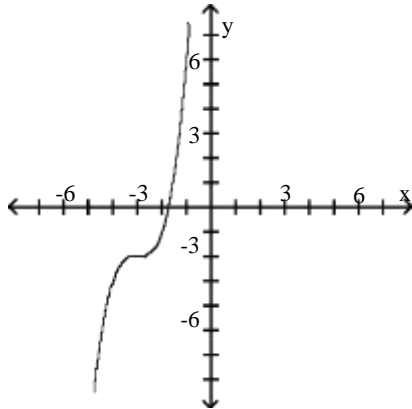

D)

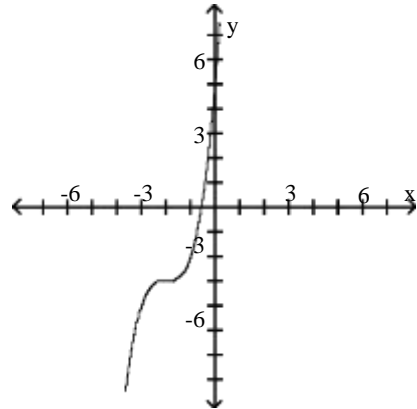

Use a graphing calculator to approximate all real solutions of the equation  $f(x) = 0$ .

6)  $f(x) = x^4 + 6x^3 + 7x^2 - 6x - 8$

A) -2, -1, 1, 4

B) -1, 1, 2, 4

C) -4, -2, 1, 1

D) -4, -2, -1, 1

Solve the problem.

- 7) The graph shows the relationship between current  $I$  and resistance  $R$  if the voltage is fixed. Find the current if the resistance is  $1,0 \Omega$ .

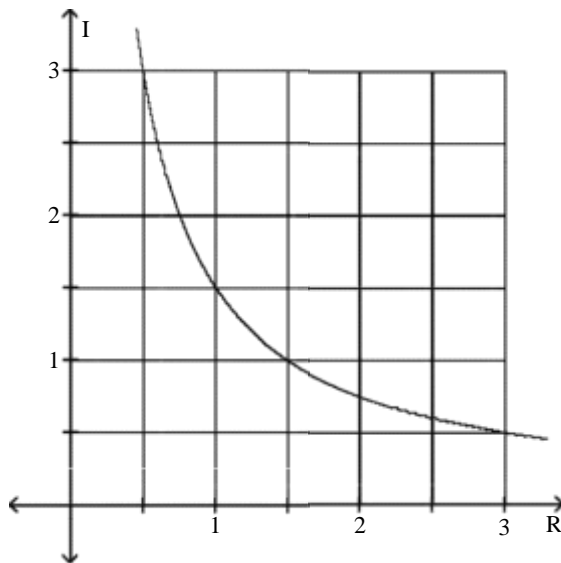

A) 3.0 A

B) 1.0 A

C) 0.75 A

D) 1.5 A

Write an equation in slope-intercept form of a line satisfying the given conditions.

8)  $m = -\frac{5}{3}$ ;  $b = \frac{37}{3}$

A)  $y = -\frac{5}{3}x + \frac{37}{3}$

B)  $y = -\frac{5}{3}x - \frac{37}{3}$

C)  $y = \frac{5}{3}x + \frac{37}{3}$

D)  $y = \frac{5}{3}x - \frac{37}{3}$

Find the slope and the y-intercept of the line.

9)  $4x - 5y = -18$

A)  $m = -\frac{4}{5}$ ;  $b = -18$

B)  $m = -\frac{5}{4}$ ;  $b = -5$

C)  $m = \frac{5}{4}$ ;  $b = \frac{18}{5}$

D)  $m = \frac{4}{5}$ ;  $b = \frac{18}{5}$

Identify whether the slope is positive, negative, zero, or undefined.

10)

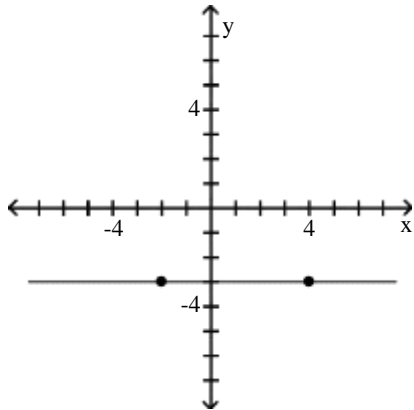

A) Positive

B) Negative

C) Zero

D) Undefined

Find the x- and y-intercepts for the equation. Then graph the equation.

11)  $6x - 12y = 24$

A)  $(4, 0), (0, -2)$

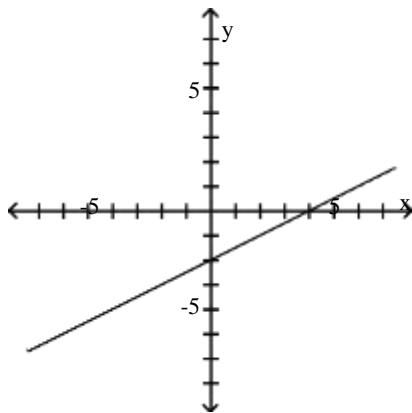

B)  $(-4, 0), (0, -2)$

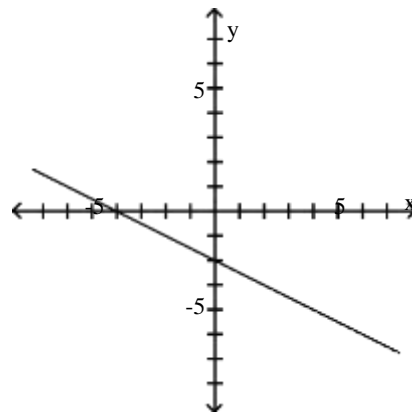

C)  $(-2, 0), (0, 4)$

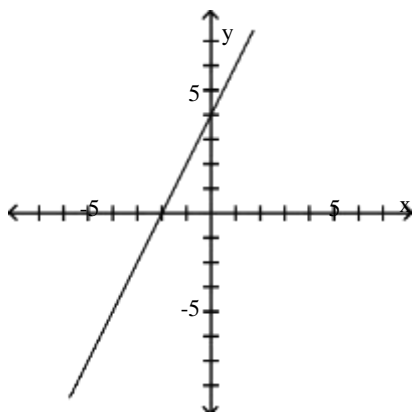

D)  $(-2, 0), (0, -4)$

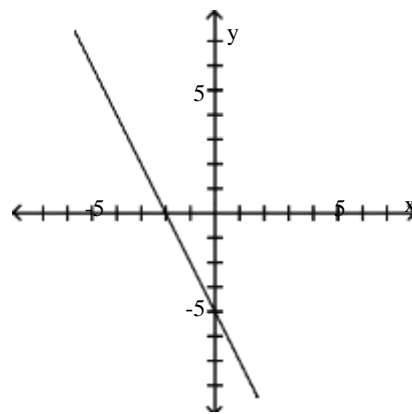

Decide whether the pair of lines is parallel, perpendicular, or neither.

12) The line through (3, -7) and (8, -2) and the line through (-6, 5) and (-8, 7)

A) Parallel

B) Perpendicular

C) Neither

Write an equation in standard form for a line passing through the pair of points.

13) (-3, -1) and (-1, 4)

A)  $5x - 2y = -13$

B)  $-5x - 2y = -13$

C)  $2x + 5y = -22$

D)  $-2x - 5y = -22$

Find an equation of the the line satisfying the given conditions.

14) Through (-5, -6); perpendicular to  $-2x - 9y = -44$

A)  $-2x - 9y = -33$

B)  $9x - 2y = -33$

C)  $9x - 2y = -50$

D)  $-5x + 9y = -44$

Convert the temperature.

15)  $18^{\circ}\text{C} = \text{\_\_}^{\circ}\text{F}$

A)  $17.5^{\circ}\text{F}$

B)  $64.4^{\circ}\text{F}$

C)  $42.0^{\circ}\text{F}$

D)  $90.0^{\circ}\text{F}$

Use a graphing calculator to compute the correlation coefficient, r.

16) The number of unemployed people in the U.S. labor force (in millions) in recent years is shown in the table below. (Data from U.S. Department of Labor, Bureau of Labor Statistics.)

Year	Unemployed
200	7,078
2008	8,924
2009	14,265
2010	14,825
2011	13,747
2012	12,506

A) 0.2578

B) 0.3618

C) 0.5077

D) 0.7125

Solve the inequality and graph the solution.

17)  $y + 2 \leq 11$

A)  $(-\infty, 9]$



B)  $(9, \infty)$

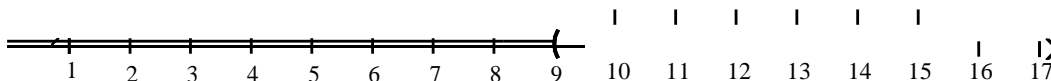

C)  $[9, \infty)$

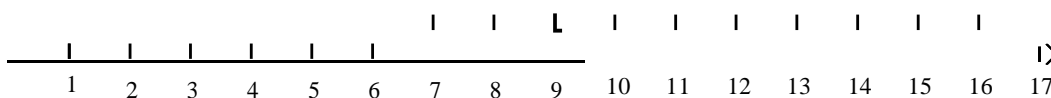

D)  $(-\infty, 9)$

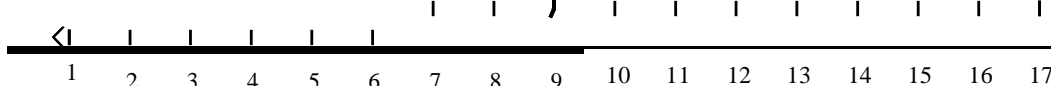

Solve the problem.

18) The equation  $y = 0.005x - 0.40$  can be used to determine the approximate cost,  $y$  in dollars, of producing  $x$  items. How many items must be produced so the cost will be no more than \$ 239?

- A)  $0 < x \leq 47,720$
- C)  $0 < x \leq 47,881$

- B)  $0 < x \leq 47,880$
- D)  $0 < x \leq 50,274.00$

Solve the inequality.

19) Tyrell Car Rental Company rents cars at the rate of \$60 per day plus \$0.10 per mile. Wayne Car Rental Company rents cars at the rate of \$25 per day plus \$0.17 per mile. If you plan to rent for one week, how many miles would you need to drive to pay less by renting from Tyrell Car Rental Company?

- A) More than 1,750 miles
- C) More than 7,000 miles

- B) More than 3,500 miles
- D) More than 5,000 miles

20)  $\frac{2x}{5-x} \geq 2x$

- A)  $(-\infty, 4]$  or  $[5, \infty)$
- B)  $[0, 4]$  or  $[5, \infty)$
- C)  $(-\infty, 0]$  or  $[4, 5)$
- D)  $[5, \infty)$

## Answer Key

Testname: CHAPTER 2 FORM B

- 1) A
- 2) B
- 3) A
- 4) C
- 5) C
- 6) D
- 7) D
- 8) A
- 9) D
- 10) C
- 11) A
- 12) B
- 13) A
- 14) B
- 15) B
- 16) D
- 17) A
- 18) B
- 19) B
- 20) C



# CHAPTER 2 FORM C

Name \_\_\_\_\_

Determine whether the given ordered pair is a solution of the given equation.

1)  $\frac{x^2}{2} + \frac{y^2}{3} = 1$ ; (1, -1)

A) Yes

B) No

Graph the linear equation.

2)  $x = -3$

A)

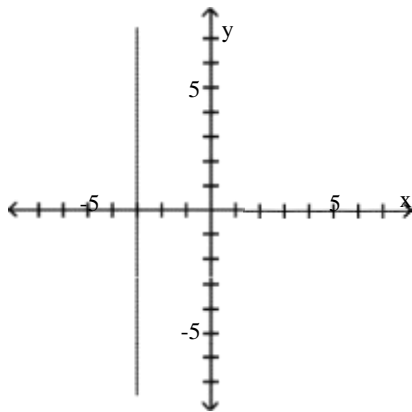

B)

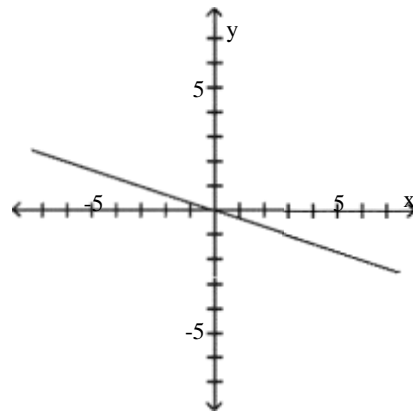

C)

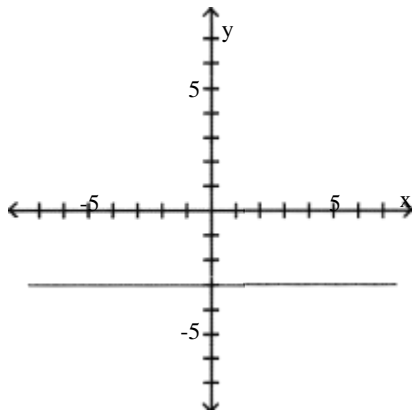

D)

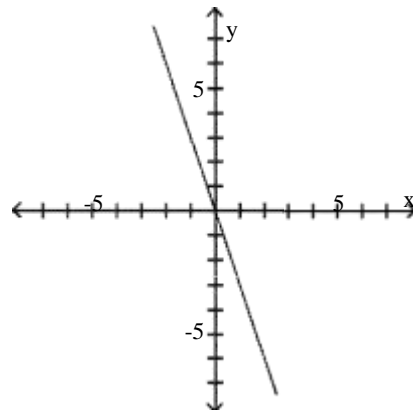

Give the x-intercepts and y-intercepts of the graph.  
3)

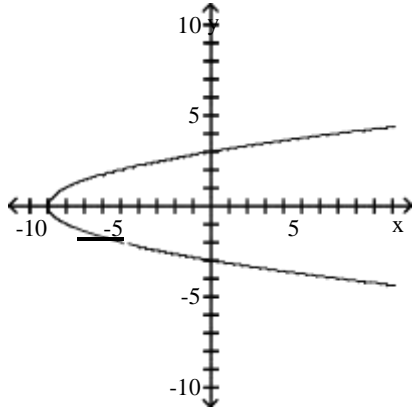

- A) x-intercepts: -3, 3; y-intercept: 9
- C) x-intercepts: -9, 0; y-intercepts: -3, 3

- B) x-intercept: -9 y-intercepts: -3, 3
- D) x-intercepts: -3, 3; y-intercept: -9

Sketch the graph of the equation.

4)  $y = x^2 - 5$

A)

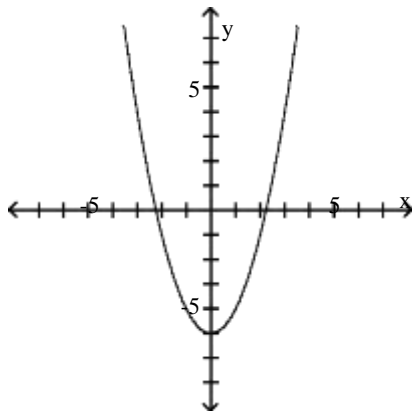

B)

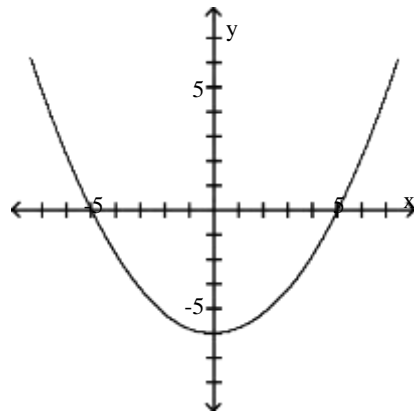

C)

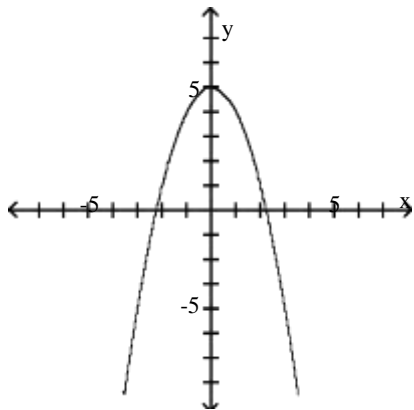

D)

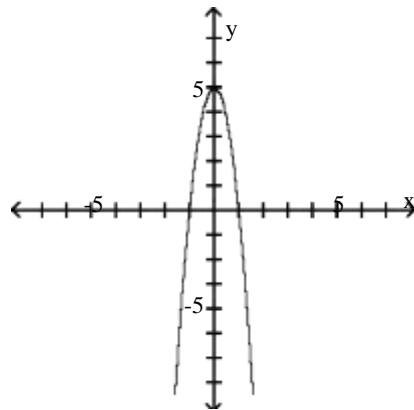

Identify the graph of the function.

5)  $f(x) = -(x - 3)^4 + 1$

A)

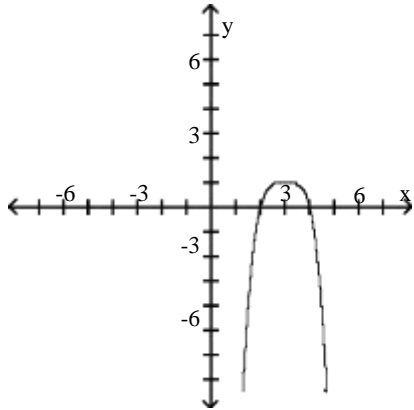

B)

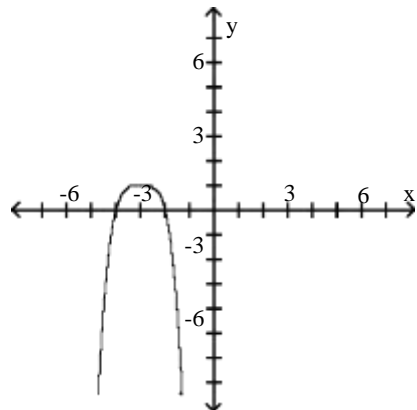

C)

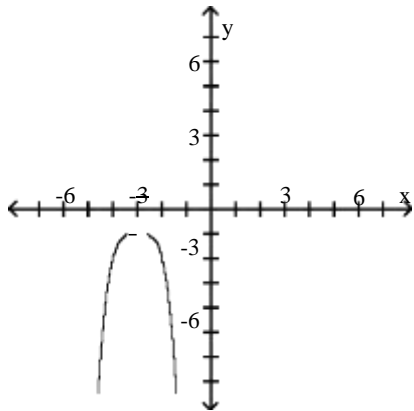

D)

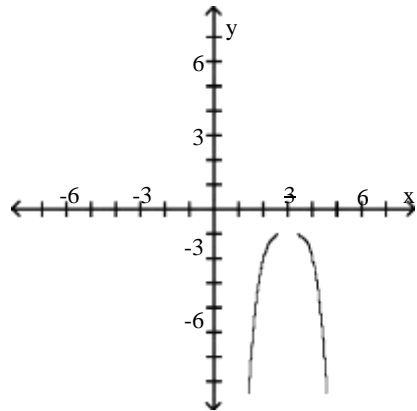

Solve the problem.

6)

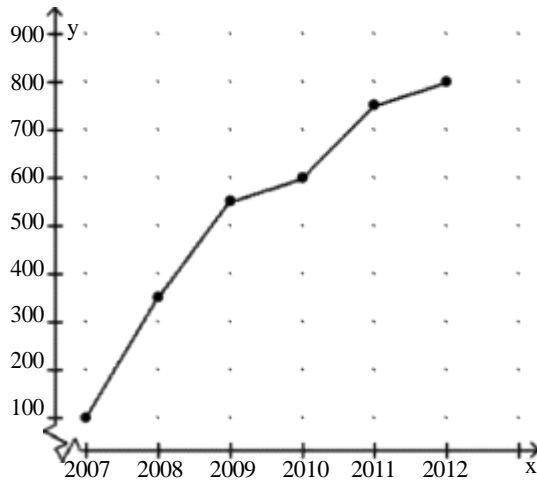

Hitek Phones opened as a mobile phone repair facility in 2007. The graph shows the number of phones repaired each year as a function of time. What is the approximate number of phones repaired in 2010?

- A) 800                                      B) 750                                      C) 600                                      D) 350

Find the slope of the line, if it is defined.

7) Through (-1, -4) and (3, 7)

- A)  $2\frac{3}{4}$                                       B)  $-2\frac{3}{4}$                                       C) 1                                      D) Undefined

Write an equation in slope-intercept form of a line satisfying the given conditions.

8)  $m = \frac{1}{2}$ ;  $b = 2$

- A)  $y = \frac{1}{2}x - 2$                                       B)  $y = -\frac{1}{2}x + 2$                                       C)  $y = \frac{1}{2}x + 2$                                       D)  $y = -\frac{1}{2}x - 2$

Find the slope and the y-intercept of the line.

9)  $x + y = 6$

- A)  $m = 0$ ;  $b = -1$                                       B)  $m = 1$ ;  $b = -6$                                       C)  $m = -1$ ;  $b = 6$                                       D)  $m = 6$ ;  $b = 0$

Choose one of the four lines graphed which most closely resembles the graph of the given equation.

10)  $y = -5x + 6$

A)

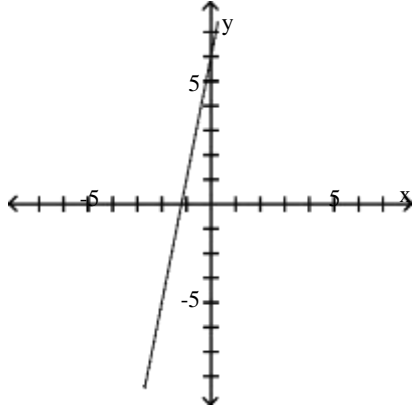

B)

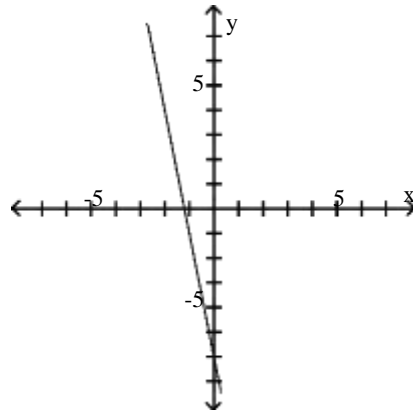

C)

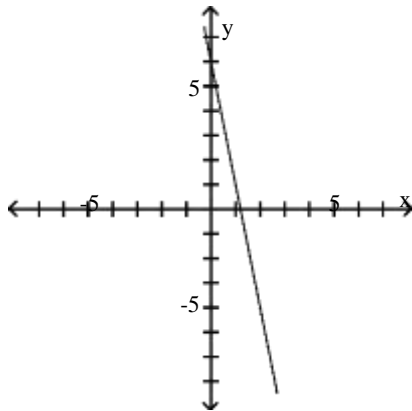

D)

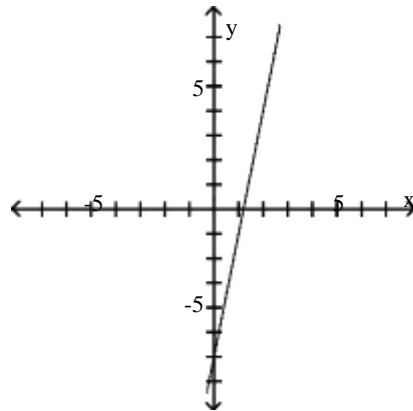

Find the x- and y-intercepts for the equation. Then graph the equation.

11)  $5x + 4y = 20$

A)  $(4, 0), (0, 5)$

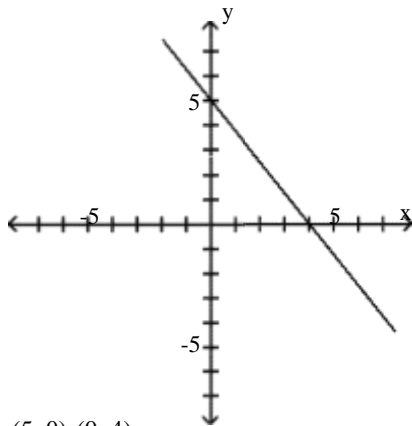

B)  $(4, 0), (0, -5)$

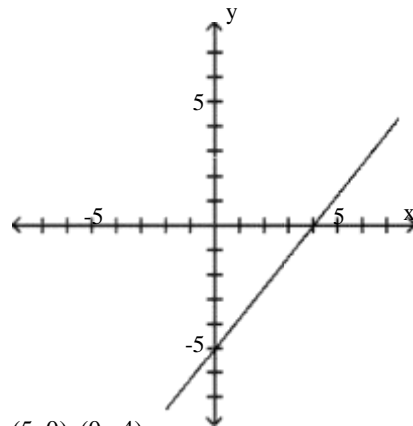

C)  $(5, 0), (0, 4)$

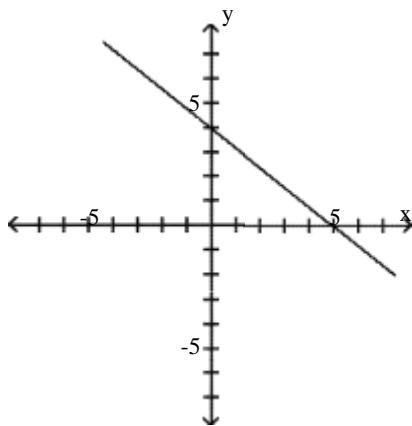

D)  $(5, 0), (0, -4)$

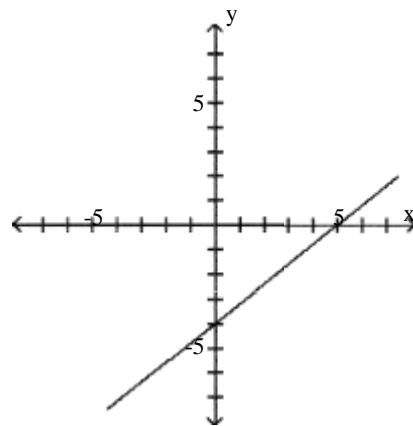

Find an equation of the line with slope  $m$  that passes through the given point. Put the answer in slope-intercept form.

12)  $(3, 4), m = -\frac{3}{7}$

A)  $y = -\frac{3}{7}x + \frac{37}{7}$

B)  $y = \frac{3}{7}x + \frac{37}{7}$

C)  $y = -\frac{3}{7}x - \frac{37}{7}$

D)  $y = \frac{3}{7}x - \frac{37}{7}$

Write an equation in standard form for a line passing through the pair of points.

13)  $(-2, 1)$  and  $(4, 1)$

A)  $-2x + 4y = 0$

B)  $4x - 2y = 0$

C)  $y = 1$

D)  $x = -2$

Solve the problem.

14) The population  $p$ , in thousands, of one town can be approximated by  $p = 5 + \frac{3}{4}d$  where  $d$  is the number of years since 2005. Estimate the population of the town in the year 2013.

- A) About 11,000      B) About 6,000      C) About 19,000      D) About 5,000

15) A meteorologist in the Upper Peninsula of Michigan predicts an overnight low of  $-18^\circ$  Fahrenheit. What would a Canadian meteorologist predict for the same location in Celsius?

- A)  $-7.8^\circ$       B)  $-10.7^\circ$       C)  $-14.7^\circ$       D)  $-27.8^\circ$

Use a graphing calculator to compute the correlation coefficient,  $r$ .

16) The following table gives the number of full-time faculty at Central State University.

Year	2007	2008	2009	2010	2011	2012
Number of Faculty	425	441	452	461	467	475

- A) 0.9421      B) 0.9145      C) 0.9706      D) 0.9852

Solve and graph the inequality and graph the solution.

17)  $-6(6y - 9) < -42y + 36$

- A)  $(-3, \infty)$

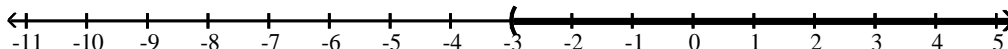

- B)  $(-42, \infty)$

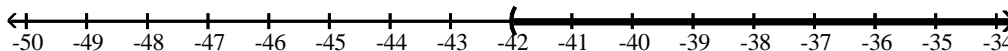

- C)  $(-\infty, -3)$

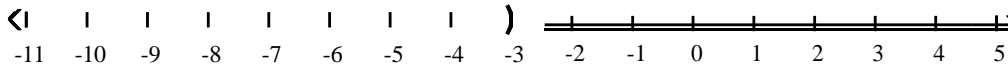

- D)  $(-\infty, -42)$

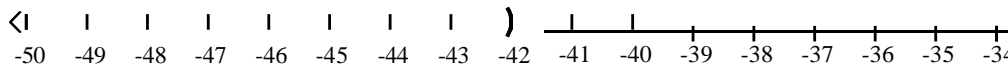

Graph the solution of the inequality.

18)  $|5x + 4| < 9$

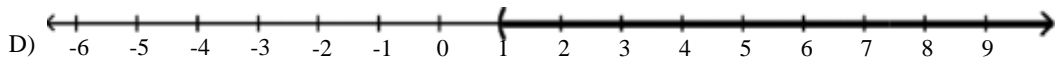
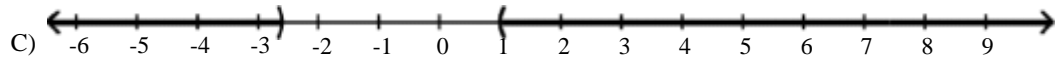
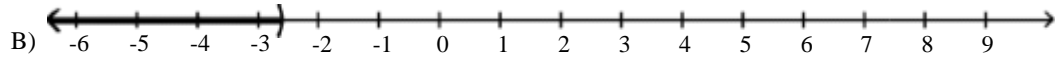
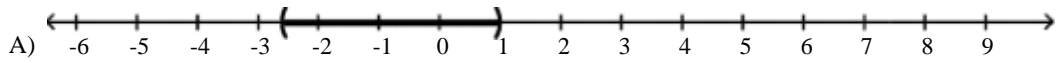

Solve the inequality and graph the solution.

19)  $(x - 3)(x + 5) > 0$

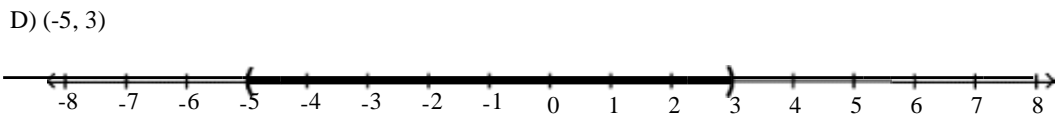
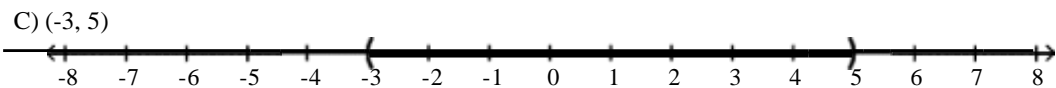
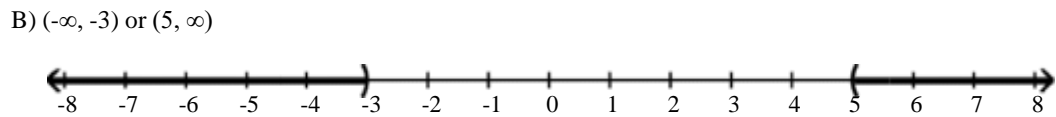
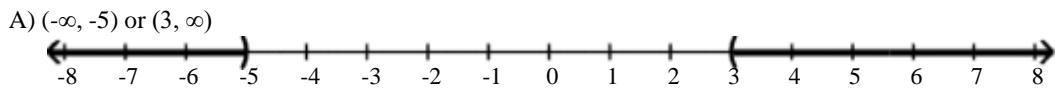

Solve the problem.

20) The cost of producing  $t$  units is  $C = 3t^2 + 8t$ , and the revenue generated from sales is  $R = 4t^2 + t$ . Determine the number of units to be sold in order to generate a profit.

A)  $t > 0$

B)  $t > 7$

C)  $t > 8$

D)  $t > 9$



## Answer Key

Testname: CHAPTER 2 FORM C

- 1) B
- 2) A
- 3) B
- 4) A
- 5) A
- 6) C
- 7) A
- 8) C
- 9) C
- 10) C
- 11) A
- 12) A
- 13) C
- 14) A
- 15) D
- 16) D
- 17) C
- 18) A
- 19) A
- 20) B

# CHAPTER 2 FORM D

Name \_\_\_\_\_

Graph the linear equation.

1)  $-5y = x - 1$

A)

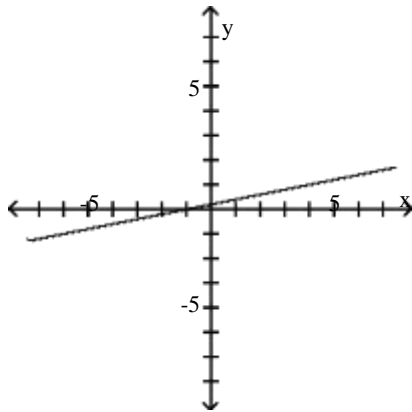

B)

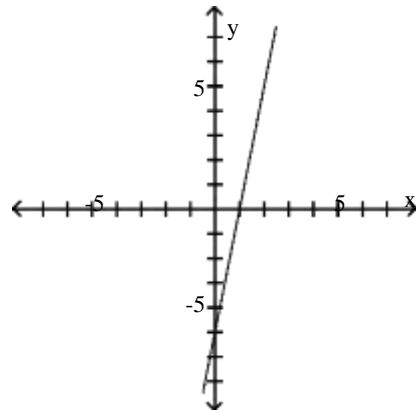

C)

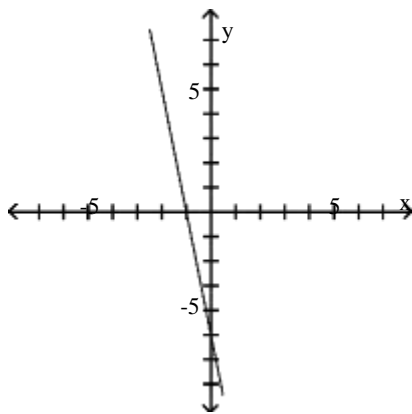

D)

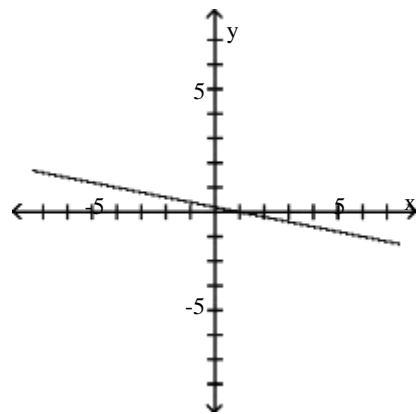

Give the x-intercepts and y-intercepts of the graph.

2)

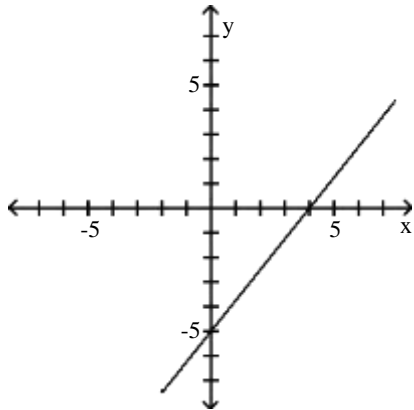

A) x-intercept: -5; y-intercept: 4

C) x-intercept: -4; y-intercept: 5

B) x-intercept: 5; y-intercept: -4

D) x-intercept: 4; y-intercept: -5

Find the x-intercepts and y-intercepts of the graph of the equation.

3)  $x + y = 5$

A) x-intercept: 3; y-intercept: 2

C) x-intercept: 2; y-intercept: 3

B) x-intercept: 5; y-intercept: 3

D) x-intercept: 5; y-intercept: 5

Sketch the graph of the equation.

4)  $y = -x^2 - 3$

A)

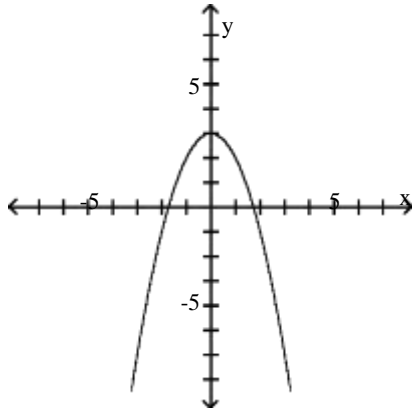

B)

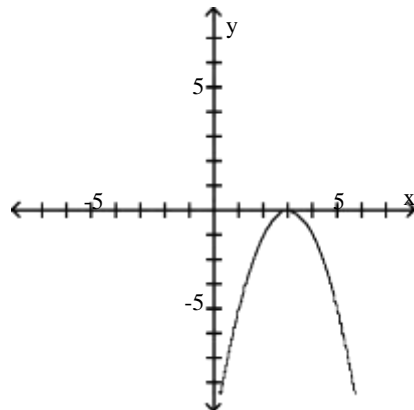

C)

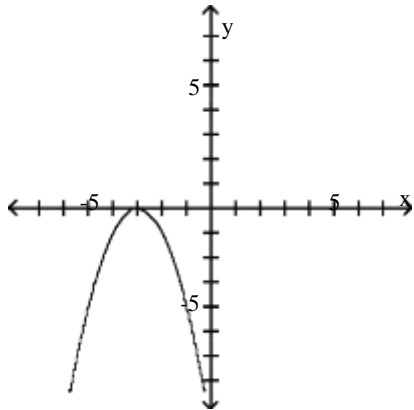

D)

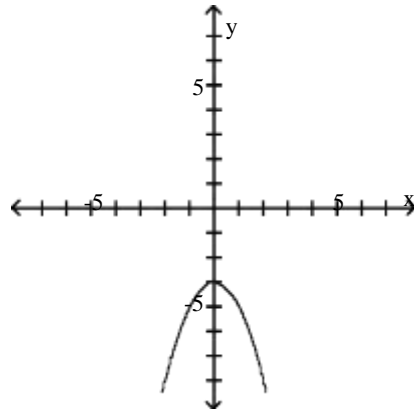

Identify the graph of the function.

$$5) y = x^3 - 3x + 2$$

A)

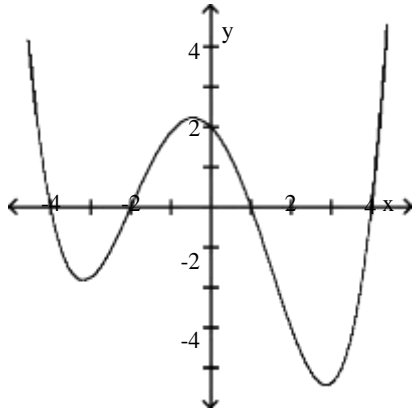

B)

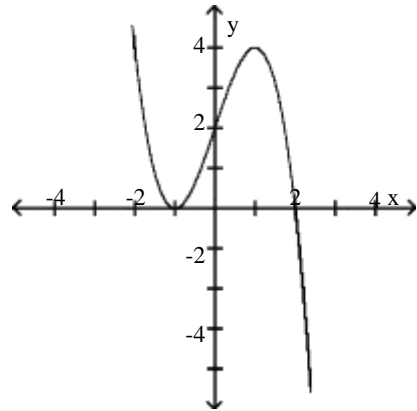

C)

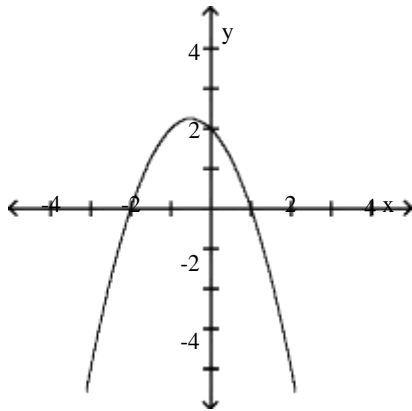

D)

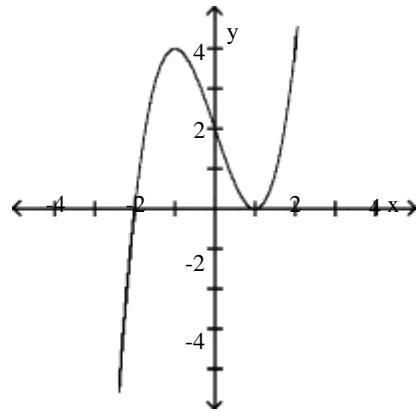

Solve the problem.

6) Sales (Thousands of Dollars)

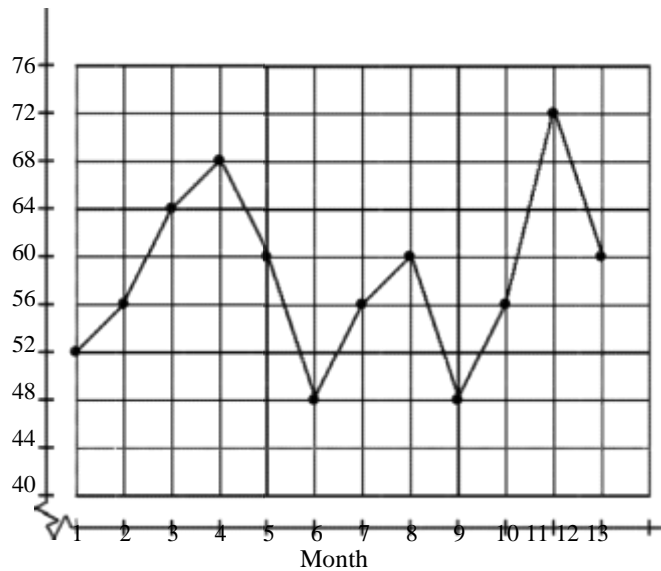

Which month(s) had the lowest sales?

- A) Month 1  
B) Months 12  
C) Months 1, 6, 9, and 12  
D) Months 6 and 9

Find the slope of the line, if it is defined.

7) Through  $(-9, -4)$  and  $(-9, 8)$

- A) 2  
B) 6  
C) 12  
D) Undefined

Write an equation in slope-intercept form of a line satisfying the given conditions.

8)  $m = \frac{7}{5}$ ;  $b = -4$

- A)  $y = \frac{7}{5}x - 4$   
B)  $y = -\frac{7}{5}x + 4$   
C)  $y = \frac{7}{5}x + 4$   
D)  $y = -\frac{7}{5}x - 4$

Identify whether the slope is positive, negative, zero, or undefined.

9)

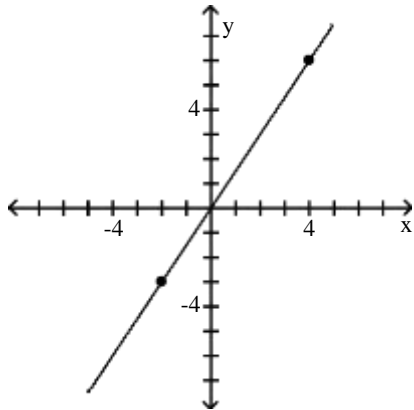

A) Positive

B) Negative

C) Zero

D) Undefined

Choose one of the four lines graphed which most closely resembles the graph of the given equation.

10)  $y = -2x + 5$

A)

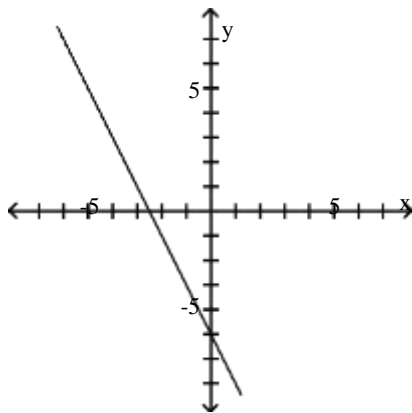

B)

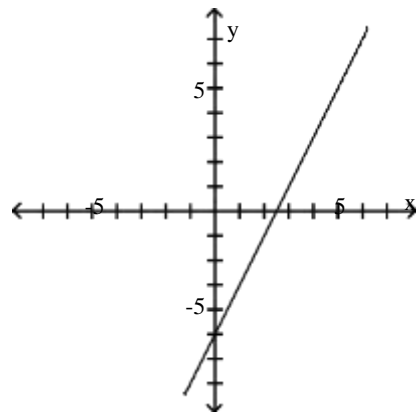

C)

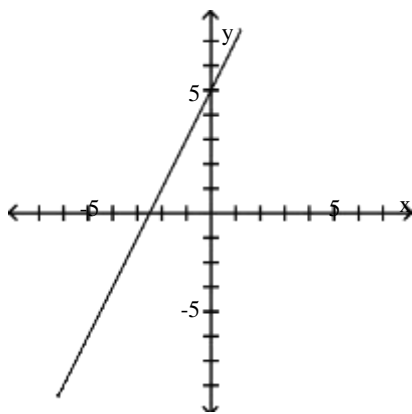

D)

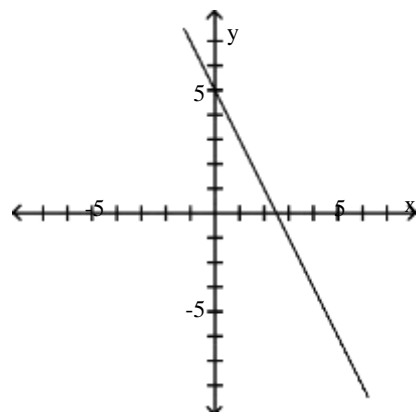

Decide whether the lines are parallel, perpendicular, or neither.

11)  $3x - 6y = -18$

$18x + 9y = -2$

A) Parallel

B) Perpendicular

C) Neither

Find an equation of the line with slope  $m$  that passes through the given point. Put the answer in slope-intercept form.

12)  $(-3, 8)$ , undefined slope

A)  $y = 8$

B)  $x = -3$

C)  $y = x \frac{3}{8}$

D)  $y = x \frac{3}{8}$

Find an equation of the the line satisfying the given conditions.

13) Through the origin with slope 9

A)  $x = 9$

B)  $y = 9$

C)  $y = -9x$

D)  $y = 9x$

Solve the problem.

14) The value,  $v$ , in hundreds of dollars, of Juan's computer is approximated by  $v = -\frac{1}{2}t + 9$ , where  $t$  is the number of years since he first bought the computer. Estimate the value of the computer 4 years after it was purchased.

A) \$1,100

B) \$820

C) \$500

D) \$700

15) Suppose the sales of a particular brand of appliance satisfy the relationship

$S(x) = 140x + 3,700$ , where  $S(x)$  represents the number of sales in year  $x$ , with  $x = 0$  corresponding to 2002. Find the number of sales in 2011.

A) 4,820

B) 4,960

C) 9,780

D) 9,920

16) The information in the chart below gives the salary of a person for the stated years. Model the data with a linear function using the points  $(1, 46,000)$  and  $(3, 53,000)$ .

x	Year	Salary
0	2000	\$ 43,000
1	2001	\$ 46,000
2	2002	\$ 50,000
3	2003	\$ 53,000
4	2004	\$ 57,000

A)  $y = 3,000x + 44,000$

B)  $y = 4,500x + 43,000$

C)  $y = 3,500x + 42,500$

D)  $y = 4,000x + 42,000$



Solve and graph the inequality and graph the solution.

$$17) \frac{7x + 8}{-21} > -\frac{26}{7}$$

A)  $(-\infty, 10)$

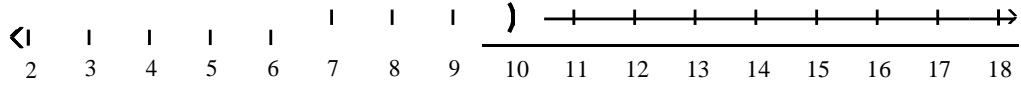

B)  $[10, \infty)$

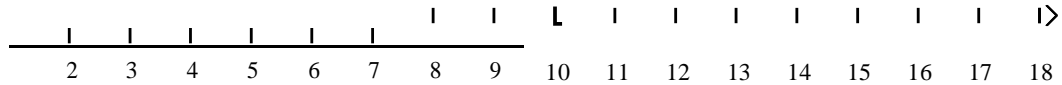

C)  $(10, \infty)$

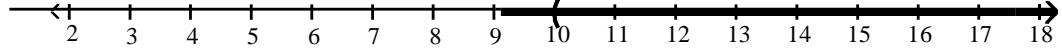

D)  $(-\infty, 10]$

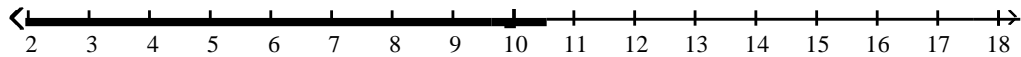

Graph the solution of the inequality.

$$18) 5|x - 3| \geq 7$$

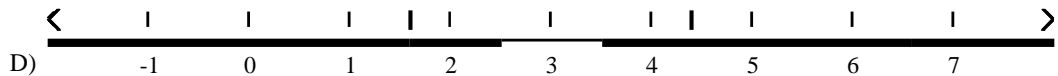
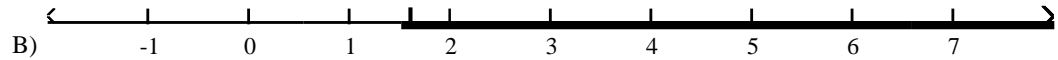
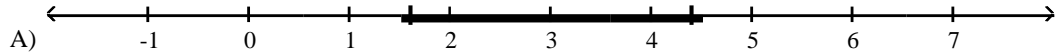

Solve the inequality and graph the solution.

19)  $x^2 + 2x \leq 15$

A)  $(-\infty, -5]$  or  $[3, \infty)$

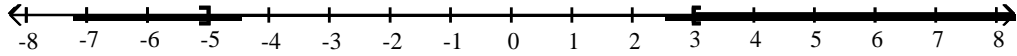

B)  $[-5, 3]$



C)  $(-\infty, 15/2]$

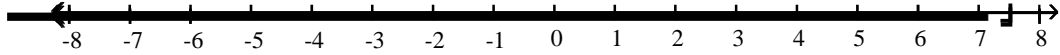

D)  $[2, \infty)$

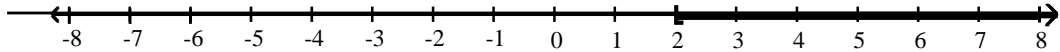

Solve the problem.

20) Lucy knows that  $n$  games can be sold in a month if the price is  $20 - 0.3n$  dollars per game. If she buys each game for \$5, and if she wishes to make a profit of at least \$180 per month on sales of this game, how many games must she sell each month?

A)  $15 \leq n \leq 25$

B)  $20 \leq n \leq 50$

C)  $20 \leq n \leq 30$

D)  $15 \leq n \leq 20$

## Answer Key

Testname: CHAPTER 2 FORM D

- 1) D
- 2) D
- 3) D
- 4) D
- 5) D
- 6) D
- 7) D
- 8) A
- 9) A
- 10) D
- 11) B
- 12) B
- 13) D
- 14) D
- 15) B
- 16) C
- 17) A
- 18) D
- 19) B
- 20) C