

**Solution Manual for Microelectronic Circuit Design 5th Edition Jaeger
Blalock 0073529605 9780073529608**

Full link download

Solution Manual:

<https://testbankpack.com/p/solution-manual-for-microelectronic-circuit-design-5th-edition-jaeger-blalock-0073529605-9780073529608/>

CHAPTER 2

2.1

Based upon Table 2.1, a resistivity of $2.82 \mu\Omega\text{-cm} < 1 \text{ m}\Omega\text{-cm}$, and aluminum is a conductor.

2.2

Based upon Table 2.1, a resistivity of $10^{15} \Omega\text{-cm} > 10^5 \Omega\text{-cm}$, and silicon dioxide is an insulator.

2.3

$$I_{\max} = \left(10^7 \frac{A}{\text{cm}^2}\right)(5\mu\text{m})(1\mu\text{m})\left(\frac{10^{-8} \text{cm}^2}{\mu\text{m}^2}\right) = 500 \text{ mA}$$

2.4

$$(a) R = r \frac{L}{A} = (2.82 \times 10^{-6} \text{ W-cm}) \frac{1.8\sqrt{2} \text{ cm}}{(5 \times 10^{-4} \text{ cm})(1 \times 10^{-4} \text{ cm})} = 144 \text{ W}$$

$$(b) R = r \frac{L}{A} = (2.82 \times 10^{-6} \text{ W-cm}) \frac{1.8\sqrt{2} \text{ cm}}{(5 \times 10^{-4} \text{ cm})(0.5 \times 10^{-4} \text{ cm})} = 287 \text{ W}$$

2.5

$$(a) R = r \frac{L}{A} = (1.66 \times 10^{-6} \text{ W-cm}) \frac{1.8\sqrt{2} \text{ cm}}{(5 \times 10^{-4} \text{ cm})(1 \times 10^{-4} \text{ cm})} = 94.5 \text{ W}$$

$$(b) R = r \frac{L}{A} = (1.66 \times 10^{-6} \text{ W-cm}) \frac{1.8\sqrt{2} \text{ cm}}{(5 \times 10^{-4} \text{ cm})(0.5 \times 10^{-4} \text{ cm})} = 169 \text{ W}$$

2.6

$$n_i^2 = BT^3 \exp\left\{-\frac{E_g}{kT}\right\}$$

$$\frac{E}{(10^{10})} = 1.08 \times 10^{31} T^3 \exp\left(-\frac{1.12}{8.62 \times 10^{-5} T}\right)$$

Using a spreadsheet, solver, or MATLAB yields T=305.23K

Define an M-File:

```
function f=temp(T)
f=1e20-1.08e31*T^3*exp(-1.12/(8.62e-5*T));
```

Then: fzero('temp',300) | ans = 305.226 K

2.7

$$n_i = \sqrt{BT^3 \exp\left(-\frac{E_G}{8.62 \times 10^{-5} T}\right)}$$
 For silicon, $B = 1.08 \times 10^{30}$ and $E_G = 1.12$ eV:

$$n_i = 5.07 \times 10^{-19} / \text{cm}^3 \quad 6.73 \times 10^9 / \text{cm}^3 \quad 1.69 \times 10^{13} / \text{cm}^3$$

For germanium, $B = 2.31 \times 10^{30}$ and $E_G = 0.66$ eV:

$$n_i = 2.63 \times 10^{-4} / \text{cm}^3 \quad 2.27 \times 10^{13} / \text{cm}^3 \quad 2.93 \times 10^{15} / \text{cm}^3$$

2.8

(a) Define an M-File:

```

function f=temp(T)
ni=1E15;
f=ni^2-1.08e31*T^3*exp(-1.12/(8.62e-5*T));
  
```

$n_i = 10^{15} / \text{cm}^3$ for $T = 602$ K

(b) $N_D = 10^{15} / \text{cm}^3$, $n_i^2 = 10^{30} / \text{cm}^6$: $n = \frac{10^{15} + \sqrt{(10^{15})^2 + 4(10^{30})}}{2} = 1.62 \times 10^{15} / \text{cm}^3$

$$p = \frac{n_i^2}{n} = \frac{10^{30}}{1.62 \times 10^{15}} = 6.18 \times 10^{14} / \text{cm}^3$$

(c) At room temperature, $N_D \gg n_i^2$.

$$n = N_D = 10^{15} \text{ electrons} / \text{cm}^3 \text{ and } p = \frac{n_i^2}{n} = \frac{10^{30}}{10^{15}} = 10^{15} \text{ holes} / \text{cm}^3$$

2.9

$$n_i = \sqrt{BT^3 \exp\left(-\frac{E_G}{8.62 \times 10^{-5} T}\right)} \quad \text{with} \quad B = 1.27 \times 10^{29} \text{ K}^{-3} \text{ cm}^{-6}$$

$T = 300$ K and $E_G = 1.42$ eV: $n_i = 2.21 \times 10^6 / \text{cm}^3$

$T = 100$ K: $n_i = 6.03 \times 10^{-19} / \text{cm}^3$ $T = 450$ K: $n_i = 3.82 \times 10^{10} / \text{cm}^3$

$T = 300$ K and $E_G = 1.42$ eV: $n_i = 2.21 \times 10^6 / \text{cm}^3$

$T = 100$ K: $n_i = 6.03 \times 10^{-19} / \text{cm}^3$ $T = 450$ K: $n_i = 3.82 \times 10^{10} / \text{cm}^3$

2.10

$$v_n = -m_n E = -\frac{1.60 \times 10^{-19} \text{ C}}{1.60 \times 10^{-19} \text{ C}} \cdot 700 \frac{\text{cm}^2 \ddot{\alpha}}{V - s \ddot{\theta}} - 2000 \frac{V \ddot{\theta}}{\text{cm} \ddot{\theta}} = +1.40 \times 10^6 \frac{\text{cm}}{s}$$

$$v_p = +m_p E = +\frac{1.60 \times 10^{-19} \text{ C}}{1.60 \times 10^{-19} \text{ C}} \cdot 250 \frac{\text{cm}^2 \ddot{\alpha}}{V - s \ddot{\theta}} - 2000 \frac{V \ddot{\theta}}{\text{cm} \ddot{\theta}} = -5.00 \times 10^5 \frac{\text{cm}}{s}$$

$$j_n = -q n v_n = \left(-1.60 \times 10^{-19} \text{ C} \right) \cdot 10^{17} \frac{1 \ddot{\alpha}}{\text{cm}^3 \ddot{\theta}} \cdot 1.40 \times 10^6 \frac{\text{cm}}{s} = 2.24 \times 10^4 \frac{\text{A}}{\text{cm}^2}$$

$$j_p = q n v_p = \left(1.60 \times 10^{-19} \text{ C} \right) \cdot 10^{17} \frac{1 \ddot{\alpha}}{\text{cm}^3 \ddot{\theta}} \cdot (-5.00 \times 10^5 \frac{\text{cm}}{s}) = -8.00 \times 10^{-11} \frac{\text{A}}{\text{cm}^2}$$

2.11

$$|j_n| = q n v_n = \left(1.60 \times 10^{-19} \text{ C} \right) \cdot 10^{18} \frac{1 \ddot{\alpha}}{\text{cm}^3 \ddot{\theta}} \cdot 10^7 \frac{\text{cm}}{s} = 1.60 \times 10^6 \frac{\text{A}}{\text{cm}^2} = 1.60 \frac{\text{MA}}{\text{cm}^2}$$

$$|j_p| = q n v_p = \left(1.60 \times 10^{-19} \text{ C} \right) \cdot 10^{17} \frac{1 \ddot{\alpha}}{\text{cm}^3 \ddot{\theta}} \cdot 10^7 \frac{\text{cm}}{s} = 1.60 \times 10^{-10} \frac{\text{A}}{\text{cm}^2} = 160 \text{ pA}$$

$$I = |j_n| \cdot \text{Area} = 1.60 \times 10^6 \frac{\text{A}}{\text{cm}^2} \left(10 \text{ cm} \right) \left(25 \times 10 \text{ cm} \right) = 400 \text{ mA}$$

2.12 $A = 4 \frac{\text{MA}}{\text{cm}^2}$

$$j = Q v = \left(0.4 \frac{\text{C}}{\text{cm}^3} \right) \left(10^7 \frac{\text{cm}}{\text{sec}} \right) = 4 \times 10^6 \frac{\text{cm}}{\text{cm}^2}$$

2.13

$$v = \frac{j}{Q} = \frac{2500 \text{ A} / \text{cm}^2}{0.01 \text{ C} / \text{cm}^2} = 2.5 \times 10^5 \frac{\text{cm}}{s}$$

2.14

$$v_n = -m_n E = -\frac{1.60 \times 10^{-19} \text{ C}}{1.60 \times 10^{-19} \text{ C}} \cdot 1000 \frac{\text{cm}^2 \ddot{\alpha}}{V - s \ddot{\theta}} - 1500 \frac{V \ddot{\theta}}{\text{cm} \ddot{\theta}} = +1.50 \times 10^6 \frac{\text{cm}}{s}$$

$$v_p = +m_p E = +\frac{1.60 \times 10^{-19} \text{ C}}{1.60 \times 10^{-19} \text{ C}} \cdot 400 \frac{\text{cm}^2 \ddot{\alpha}}{V - s \ddot{\theta}} - 1500 \frac{V \ddot{\theta}}{\text{cm} \ddot{\theta}} = -6.00 \times 10^5 \frac{\text{cm}}{s}$$

$$V = 10 \text{ V}$$

$$j_n = -qnv_n = (-1.60 \times 10^{-19} \text{ C}) \left(10^3 \frac{1}{\text{cm}^3} + 1.50 \times 10^6 \frac{\text{cm}}{\text{s}} \right) = -2.40 \times 10^{-10} \frac{\text{A}}{\text{cm}^2}$$

$$j_p = qnv_p = (1.60 \times 10^{-19} \text{ C}) \left(10^3 \frac{1}{\text{cm}^3} - 6.00 \times 10^5 \frac{\text{cm}}{\text{s}} \right) = -9.60 \times 10^{-10} \frac{\text{A}}{\text{cm}^2}$$

2.15

$$(a) \quad E = \frac{5V}{5 \times 10^{-4} \text{ cm}} = 10,000 \frac{V}{\text{cm}} \quad (b) \quad V = \frac{10^5}{\text{cm}} \frac{V}{\text{cm}} (5 \times 10^{-4} \text{ cm}) = 50 \text{ V}$$

2.16

For intrinsic silicon, $S = q(m_n n_i + m_p n_i) = q n_i (m_n + m_p)$

$S = 10^{-5} (W - cm)^{-1}$ for an insulator

$$n_i = \frac{S}{q(m_n + m_p)} = \frac{10^{-5} (W - cm)^{-1}}{(1.602 \times 10^{-19} C)(1800 + 700) \frac{cm^2}{v - sec}} = \frac{2.497 \times 10^{10}}{cm^3}$$

$$n_i^2 = \frac{5.152 \times 10^{20}}{cm^6} = BT^3 \exp\left(-\frac{E_G}{kT}\right) \text{ with}$$

$B = 1.08 \times 10^{31} K^{-3} cm^{-6}$, $k = 8.62 \times 10^{-5} eV/K$ and $E_G = 1.12 eV$

Using MATLAB as in Problem 2.6 yields $T \leq 316.6 \text{ K}$.

2.17

For intrinsic silicon, $S = q(m_n n_i + m_p n_i) = q n_i (m_n + m_p)$

$S = 1000 (W - cm)^{-1}$ for a conductor

$$n_i = \frac{S}{q(m_n + m_p)} = \frac{1000 (W - cm)^{-1}}{1.602 \times 10^{-19} C(120 + 60) \frac{cm^2}{v - sec}} = \frac{3.468 \times 10^{19}}{cm^3}$$

$$n_i^2 = \frac{1.203 \times 10^{39}}{cm^6} = BT^3 \exp\left(-\frac{E_G}{kT}\right) \text{ with}$$

$B = 1.08 \times 10^{31} K^{-3} cm^{-6}$, $k = 8.62 \times 10^{-5} eV/K$ and $E_G = 1.12 eV$

This is a transcendental equation and must be solved numerically by iteration. Using the HP solver routine or a spread sheet yields $T \geq 2579.3 \text{ K}$. Note that this temperature is far above the melting temperature of silicon.

2.18

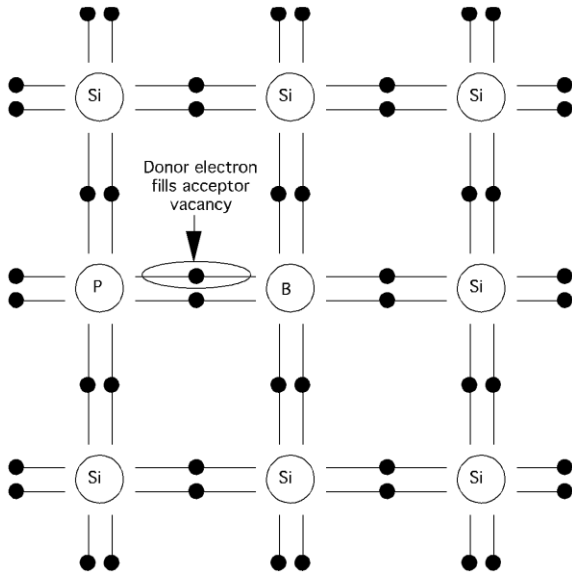

No free electrons or holes (except those corresponding to n_i).

2.19

Since Ge is also from column IV, acceptors come from column III and donors come from column V. (a) Acceptors: B, Al, Ga, In, Tl (b) Donors: N, P, As, Sb, Bi

2.20

(a) Gallium is from column 3 and silicon is from column 4. Thus silicon has an extra electron and will act as a donor impurity.

(b) Arsenic is from column 5 and silicon is from column 4. Thus silicon is deficient in one electron and will act as an acceptor impurity.

2.21

(a) Germanium is from column IV and indium is from column III. Thus germanium has one extra electron and will act as a donor impurity.

(b) Germanium is from column IV and phosphorus is from column V. Thus germanium has one less electron and will act as an acceptor impurity.

2.22

$$E = \frac{j}{\sigma} = \frac{A}{5000} \frac{\dot{Q}}{cm^2} (0.02W - cm) = 100 \frac{V}{cm}, \text{ a small electric field}$$

2.23

$$N = \frac{\approx 10^{16} atoms}{cm^3} \div (0.180mm)(2mm)(0.5mm) = \frac{\approx 10^{-4} cm^3}{mm^3} \div = 1800 atoms$$

2.24

(a) Since boron is an acceptor, $N_A = 7 \times 10^{18}/\text{cm}^3$. Assume $N_D = 0$, since it is not specified. The material is p-type.

(b) At room temperature, $n_i = 10^{10}/\text{cm}^3$ and $N_A - N_D = 7 \times 10^{18}/\text{cm}^3 \gg 2n_i$

$$\text{So } p = 7 \times 10^{18} / \text{cm}^3 \text{ and } n = \frac{n_i}{p} = \frac{10^{10} / \text{cm}^3}{7 \times 10^{18} / \text{cm}^3} = 14.3 / \text{cm}^3$$

(c) At 200K, $n_i^2 = 1.08 \times 10^{31} (200)^3 \exp\left(-\frac{1.12}{8.62 \times 10^{-5} (200)}\right) = 5.28 \times 10^9 / \text{cm}^6$

$$n_i = 7.27 \times 10^4 / \text{cm}^3 \quad N_A - N_D \gg 2n_i, \text{ so } p = 7 \times 10^{18} / \text{cm}^3 \text{ and } n = \frac{5.28 \times 10^9}{7 \times 10^{18}} = 7.54 \times 10^{-10} / \text{cm}^3$$

2.25

(a) Since arsenic is a donor, $N_D = 3 \times 10^{17}/\text{cm}^3$. Assume $N_A = 0$, since it is not specified. The material is n-type.

(b) At room temperature, $n_i = 10^{10}/\text{cm}^3$ and $N_D - N_A = 3 \times 10^{17}/\text{cm}^3 \gg 2n_i$

$$\text{So } n = 3 \times 10^{17} / \text{cm}^3 \text{ and } p = \frac{n_i}{n} = \frac{10^{20} / \text{cm}^6}{3 \times 10^{17} / \text{cm}^3} = 333 / \text{cm}^3$$

(c) At 250K, $n_i^2 = 1.08 \times 10^{31} (250)^3 \exp\left(-\frac{1.12}{8.62 \times 10^{-5} (250)}\right) = 4.53 \times 10^{15} / \text{cm}^6$

$$n_i = 6.73 \times 10^7 / \text{cm}^3 \quad N_D - N_A \gg 2n_i, \text{ so } n = 3 \times 10^{17} / \text{cm}^3 \text{ and } p = \frac{4.53 \times 10^{15}}{3 \times 10^{17}} = 0.0151 / \text{cm}^3$$

2.26

(a) Arsenic is a donor, and boron is an acceptor. $N_D = 3 \times 10^{18}/\text{cm}^3$, and $N_A = 8 \times 10^{18}/\text{cm}^3$. Since $N_A > N_D$, the material is p-type.

(b) At room temperature, $n_i = 10^{10}/\text{cm}^3$ and $N_A - N_D = 5 \times 10^{18}/\text{cm}^3 \gg 2n_i$

$$\text{So } p = 5 \times 10^{18} / \text{cm}^3 \text{ and } n = \frac{n_i}{p} = \frac{10^{10} / \text{cm}^3}{5 \times 10^{18} / \text{cm}^3} = 20.0 / \text{cm}^3$$

2.27

(a) Phosphorus is a donor, and boron is an acceptor. $N_D = 2 \times 10^{17}/\text{cm}^3$, and $N_A = 6 \times 10^{17}/\text{cm}^3$. Since $N_A > N_D$, the material is p-type.

(b) At room temperature, $n_i = 10^{10}/\text{cm}^3$ and $N_A - N_D = 4 \times 10^{17}/\text{cm}^3 \gg 2n_i$

$$\text{So } p = 4 \times 10^{17} / \text{cm}^3 \text{ and } n = \frac{n_i}{p} = \frac{10^{10} / \text{cm}^3}{4 \times 10^{17} / \text{cm}^3} = 250 / \text{cm}^3$$

2.28

$N_D > N_A$: The material is n - type. $N_D - N_A = 3 \times 10^{17} - 2 \times 10^{17} = 1 \times 10^{17} / \text{cm}^3$
 $2n_i = 2 \times 10^{17} / \text{cm}^3$; Need to use Eq. (2.11)

$$n = \frac{10^{17} + \sqrt{(10^{17})^2 + 4(10^{17})^2}}{2} = 1.62 \times 10^{17} / \text{cm}^3$$

$$p = \frac{n_i^2}{n} = \frac{10^{34}}{1.62 \times 10^{17}} = 6.18 \times 10^{16} / \text{cm}^3$$

2.29

$N_A > N_D$: $N_A - N_D = 5 \times 10^{16} - 10^{16} = 4 \times 10^{16} / \text{cm}^3 \gg 2n_i = 2 \times 10^{11} / \text{cm}^3$

$$p = N_A - N_D = 4 \times 10^{16} / \text{cm}^3 \quad | \quad n = \frac{n_i^2}{p} = \frac{10^{22}}{4 \times 10^{16}} = 2.50 \times 10^5 / \text{cm}^3$$

The material is p - type.

2.30

$N_D = 5 \times 10^{16} / \text{cm}^3$. Assume $N_A = 0$, since it is not specified.

$N_D > N_A$: The material is n-type. $| N_D - N_A = 5 \times 10^{16} / \text{cm}^3 \gg 2n_i = 2 \times 10^{10} / \text{cm}^3$

$$n = 5 \times 10^{16} / \text{cm}^3 \quad | \quad p = \frac{n_i^2}{n} = \frac{10^{20}}{5 \times 10^{16}} = 2 \times 10^3 / \text{cm}^3$$

$$N_D + N_A = 5 \times 10^{16} / \text{cm}^3 \quad | \quad \text{Using the equations in Fig. 2.8, } m_n = 885 \frac{\text{cm}^2}{V-s} \text{ and } m_p = 198 \frac{\text{cm}^2}{V-s}$$

$$r = \frac{1}{qm_n n} = \frac{1}{(1.602 \times 10^{-19} C) \cdot 885 \frac{\text{cm}^2}{V-s} \cdot 5 \times 10^{16} / \text{cm}^3} = 0.141 \text{ W-cm}$$

2.31

$N_A = 2.5 \times 10^{18} / \text{cm}^3$. Assume $N_D = 0$, since it is not specified.

$N_A > N_D$: The material is p-type. $| N_A - N_D = 2.5 \times 10^{18} / \text{cm}^3 \gg 2n_i = 2 \times 10^{10} / \text{cm}^3$

$$p = 2.5 \times 10^{18} / \text{cm}^3 \quad | \quad n = \frac{n_i^2}{p} = \frac{10^{20}}{2.5 \times 10^{18}} = 40 / \text{cm}^3$$

$$N_D + N_A = 2.5 \times 10^{18} / \text{cm}^3 \quad | \quad \text{Using the equations from Fig. 2.8, } m_n = 187 \frac{\text{cm}^2}{V-s} \text{ and } m_p = 58.7 \frac{\text{cm}^2}{V-s}$$

$$r = \frac{1}{qm_p p} = \frac{1}{(1.602 \times 10^{-19} C) \cdot 58.7 \frac{\text{cm}^2}{V-s} \cdot 2.5 \times 10^{18} / \text{cm}^3} = 42.5 \text{ mW-cm}$$

$$1.602 \times 10^{-19} \frac{C}{e} \cdot 58.7 \frac{cm}{s} \cdot \frac{2.5 \times 10^{18}}{cm^3} \cdot \frac{1}{\emptyset}$$

2.32

Indium is from column 3 and is an acceptor. $N_A = 8 \times 10^{19}/\text{cm}^3$. Assume $N_D = 0$, since it is not specified.

$$N_A > N_D : \text{material is p-type} \mid N_A - N_D = 8 \times 10^{19} / \text{cm}^3 \gg 2n_i = 2 \times 10^{10} / \text{cm}^3$$

$$p = 8 \times 10^{19} / \text{cm}^3 \mid n = \frac{n_i^2}{p} = \frac{10^{20}}{8 \times 10^{19}} = 1.25 / \text{cm}^3$$

$$N_D + N_A = 7 \times 10^{19} / \text{cm}^3 \mid \text{Using Fig. 2.8, } m_n = 66.2 \frac{\text{cm}^2}{V-s} \text{ and } m_p = 46.1 \frac{\text{cm}^2}{V-s}$$

$$r = \frac{1}{qm_p p} = \frac{1}{1.602 \times 10^{-19} \text{ C} \cdot 46.1 \frac{\text{cm}^2}{V-s} \cdot 8 \times 10^{19} / \text{cm}^3} = 1.69 \text{ mW-cm}$$

2.33

Phosphorus is a donor: $N_D = 4.5 \times 10^{16} / \text{cm}^3$ | Boron is an acceptor: $N_A = 5.5 \times 10^{16} / \text{cm}^3$

$$N_A > N_D : \text{The material is p-type.} \mid N_A - N_D = 10^{16} / \text{cm}^3 \gg 2n_i = 2 \times 10^{10} / \text{cm}^3$$

$$p = 10^{16} / \text{cm}^3 \mid n = \frac{n_i^2}{p} = \frac{10^{20}}{10^{16}} = 10^4 / \text{cm}^3$$

$$N_D + N_A = 10^{17} / \text{cm}^3 \mid \text{Using Fig. 2.8, } m_n = 727 \frac{\text{cm}^2}{V-s} \text{ and } m_p = 153 \frac{\text{cm}^2}{V-s}$$

$$r = \frac{1}{qm_n n} = \frac{1}{1.602 \times 10^{-19} \text{ C} \cdot 153 \frac{\text{cm}^2}{V-s} \cdot 10^{16} / \text{cm}^3} = 4.08 \text{ W-cm}$$

2.34

$$\rho = \frac{1}{q\mu_p p} \mid \mu_p p = \frac{1}{(1.602 \times 10^{-19} \text{ C})(0.054 \Omega - \text{cm})} = \frac{1.16 \times 10^{20}}{V - \text{cm} - s}$$

An iterative solution is required. Using the equations from Fig. 2.8 and trial and error:

N_A	μ_p	$\mu_p p$
10^{18}	70.8	7.08×10^{19}
2×10^{18}	61.0	1.22×10^{20}

1.90×10^{18}	61.6	1.17×10^{20}
1.89×10^{18}	61.6	1.16×10^{20}

2.39 (a)

$$\rho = \frac{1}{q\mu_n n} \quad | \quad \mu_n n \approx \mu_n N_D = \frac{1}{(1.602 \times 10^{-19} C)(0.001 \Omega - cm)} = \frac{6.24 \times 10^{21}}{V - cm - s}$$

An iterative solution is required. Using the equations in Fig. 2.8 and trial and error:

N_D	μ_n	$\mu_n n$
10^{19}	108	1.08×10^{21}
7×10^{19}	67.5	4.73×10^{21}
1×10^{21}	64.3	6.43×10^{21}
9.67×10^{19}	64.5	6.24×10^{21}

(b)

$$\rho = \frac{1}{q\mu_p p} \quad | \quad \mu_p p \approx \mu_p N_A = \frac{1}{(1.602 \times 10^{-19} C)(0.001 \Omega - cm)} = \frac{6.24 \times 10^{21}}{V - cm - s}$$

An iterative solution is required using the equations in Fig. 2.8 and trial and error:

N_A	μ_p	$\mu_p p$
1×10^{20}	45.9	4.96×10^{21}
1.2×10^{20}	45.8	5.93×10^{21}
1.4×10^{20}	45.7	6.17×10^{21}
1.37×10^{20}	45.7	6.26×10^{21}

2.40

(a) For the 1 ohm-cm starting material:

$$\rho = \frac{1}{q\mu_p p} \quad | \quad \mu_p p \approx \mu_p N_A = \frac{1}{(1.602 \times 10^{-19} C)(1 \Omega - cm)} = \frac{6.25 \times 10^{18}}{V - cm - s}$$

To change the resistivity to 0.25 ohm-cm:

$$\rho = \frac{1}{q\mu_p p} \quad | \quad \mu_p p \approx \mu_p N_A = \frac{1}{(1.602 \times 10^{-19} C)(0.25 \Omega - cm)} = \frac{2.5 \times 10^{19}}{V - cm - s}$$

Iterative solutions are required using the equations with Fig. 2.8 and trial and error:

<input type="checkbox"/> <input type="checkbox"/> <input type="checkbox"/> <input type="checkbox"/> <input type="checkbox"/> <input type="checkbox"/> <input type="checkbox"/> <input type="checkbox"/> <input type="checkbox"/>	N_A	μ_p	$\mu_p p$
1 Ohm-cm	2.51×10^{16}	249	6.25×10^{18}
0.25 Ohm-cm	2.2×10^{17}	147	2.5×10^{18}

Additional acceptor concentration = $2.2 \times 10^{17} - 2.5 \times 10^{16} = 1.95 \times 10^{16}/cm^3$

(b) If donors are added:

N_D	$N_D + N_A$	μ_n	$N_D - N_A$	$\mu_n n$
3×10^{16}	5.5×10^{16}	864	0.5×10^{15}	4.32×10^{18}
5×10^{16}	7.5×10^{16}	794	2.5×10^{16}	1.98×10^{19}
6×10^{16}	8.5×10^{16}	765	3.5×10^{16}	2.68×10^{19}
5.74×10^{16}	8.24×10^{16}	772	3.24×10^{16}	2.50×10^{19}

So $N_D = 5.7 \times 10^{16}/cm^3$ must be added to change achieve a resistivity of 0.25 ohm-cm. The silicon is converted to n-type material.

2.41

Boron is an acceptor: $N_A = 10^{16}/\text{cm}^3$ and $\mu_p = 318 \text{ cm}^2/\text{V-s}$ from equations with Fig. 2.8.

$$\left(\frac{\sigma}{q \mu_p N_A} \right)^{-1} = \frac{0.509}{W - cm}$$

Now we add donors until $\sigma = 4.5 (\Omega\text{-cm})^{-1}$:

$$s = q m_n n \quad | \quad m_n n \gg m_p (N_D - N_A) = \frac{4.5(W - cm)^{-1}}{1.602 \times 10^{-19} \text{ C}} = \frac{2.81 \times 10^{19}}{V - cm - s}$$

Using trial and error:

N_D	$N_D + N_A$	μ_n	$N_D - N_A$	$\mu_n n$
8×10^{16}	9×10^{16}	752	7×10^{16}	5.26×10^{19}
5×10^{16}	6×10^{16}	845	4×10^{16}	3.38×10^{19}
4×10^{16}	5×10^{16}	885	3×10^{16}	2.66×10^{19}
4.2×10^{16}	5.2×10^{16}	877	3.2×10^{16}	2.81×10^{19}

2.42

Phosphorus is a donor: $N_D = 10^{16}/\text{cm}^3$ and $\mu_n = 1180 \text{ cm}^2/\text{V-s}$ from Fig. 2.8.

$$\left(\frac{\sigma}{q \mu_n N_D} \right)^{-1} = \frac{1.89}{W - cm}$$

Now we add acceptors until $\sigma = 5.0 (\Omega\text{-cm})^{-1}$:

$$s = q m_p p \quad | \quad m_p p \gg m_n (N_A - N_D) = \frac{5(W - cm)^{-1}}{1.602 \times 10^{-19} \text{ C}} = \frac{3.12 \times 10^{19}}{V - cm - s}$$

Using trial and error:

N_A	$N_D + N_A$	μ_p	$N_A - N_D$	$\mu_p p$
$1.00\text{E}+17$	$1.10\text{E}+17$	147	$9.00\text{E}+16$	$1.33\text{E}+19$
$2.00\text{E}+17$	$2.10\text{E}+17$	116	$1.90\text{E}+17$	$2.20\text{E}+19$
$3.50\text{E}+17$	$3.60\text{E}+17$	95.6	$3.40\text{E}+17$	$3.25\text{E}+19$
$3.30\text{E}+17$	$3.40\text{E}+17$	97.4	$3.20\text{E}+17$	$3.12\text{E}+19$

2.43

$$V_T = \frac{kT}{q} = \frac{1.38 \times 10^{-23} T}{1.602 \times 10^{-19}} = 8.62 \times 10^{-5} T$$

T (K)	50	75	100	150	200	250	300	350	400
V_T (mV)	4.31	6.46	8.61	12.9	17.2	21.5	25.8	30.1	34.5

2.44

$$j = -qD_n \frac{dn}{dx} = qV_T m_n \frac{dn}{dx}$$

$$j = (1.602 \times 10^{-19} C) (0.025 V) \left(350 \frac{cm}{s} \right) \frac{0 - 10^{19} cm^{-3}}{2 \times 10^{-4} cm} = -56.1 \frac{kA}{cm^2}$$

2.45

$$j = -qD_p \frac{dp}{dx} = (-1.602 \times 10^{-19} C) \left(15 \frac{cm^2}{s} \right) \left(-\frac{10^{19} / cm^3}{2 \times 10^{-4} cm} \right) \exp\left(-\frac{x}{2 \times 10^{-4} cm}\right)$$

$$j = 1.20 \times 10^5 \exp\left(-5000 \frac{x}{cm}\right) \frac{A}{cm^2}$$

$$I(0) = j(0)A = \left(1.20 \times 10^5 \frac{A}{cm^2} \right) (10 \mu m^2) \left(\frac{10^{-8} cm^2}{\mu m^2} \right) = 12.0 mA$$

2.46

$$j_p = q\mu_p pE - qI_p \frac{dp}{dx} = q\mu_p p \left(E - V_T \frac{1}{p} \frac{dp}{dx} \right) = 0 \rightarrow E = V_T \frac{1}{p} \frac{dp}{dx}$$

$$E \approx V_T \frac{1}{N_A} \frac{dN_A}{dx} = 0.025 \frac{-10^{22} \exp(-10^4 x)}{10^{14} + 10^{18} \exp(-10^4 x)}$$

$$E(0) = -0.025 \frac{10^{22}}{10^{14} + 10^{18}} = -250 \frac{V}{cm}$$

$$E(5 \times 10^{-4} cm) = -0.025 \frac{10^{22} \exp(-5)}{10^{14} + 10^{18} \exp(-5)} = -246 \frac{V}{cm}$$

2.47

At $x = 0$:

$$j_n^{drift} = qm_n nE = (1.60 \times 10^{-19} C) \left(350 \frac{cm}{s} \right) \frac{10^{16} cm^{-3}}{2} \frac{25 V}{cm} = 14.0 \frac{A}{cm^2}$$

$$j_p^{drift} = qm_p pE = (1.60 \times 10^{-19} C) \left(150 \frac{cm}{s} \right) \frac{1.01 \times 10^{18} cm^{-3}}{2} \frac{25 V}{cm} = +606 \frac{A}{cm^2}$$

$$j_n = qD_n \frac{dn}{dx} = (1.60 \times 10^{-19} \text{ C}) \left(\frac{350 \times 0.025}{2 \times 10^{-4} \text{ cm}^2} \right) \left(\frac{10^{-10} - 10^{-6}}{2 \times 10^{-4} \text{ cm}} \right) = -70.0 \frac{\text{A}}{\text{cm}^2}$$

$$j_p = -qD_p \frac{dp}{dx} = (-1.60 \times 10^{-19} \text{ C}) \left(\frac{150 \times 0.025}{2 \times 10^{-4} \text{ cm}^2} \right) \left(\frac{10^{-10} - 1.01 \times 10^{-6}}{2 \times 10^{-4} \text{ cm}} \right) = 30.0 \frac{\text{A}}{\text{cm}^2}$$

$$j_T = 14.0 + 607 - 70.0 + 30.0 = +580 \frac{\text{A}}{\text{cm}^2}$$

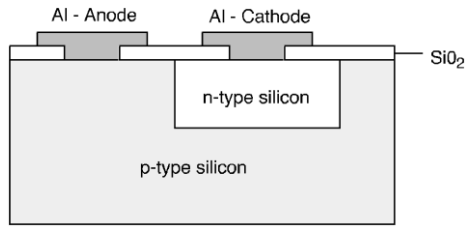

2.51

An n-type ion implantation step could be used to form the n⁺ region following step (f) in Fig. 2.17. A mask would be used to cover up the opening over the p-type region and leave the opening over the n-type silicon. The masking layer for the implantation could just be photoresist.

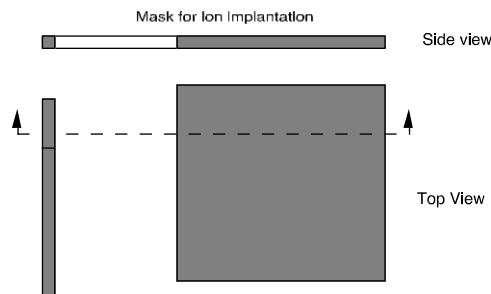
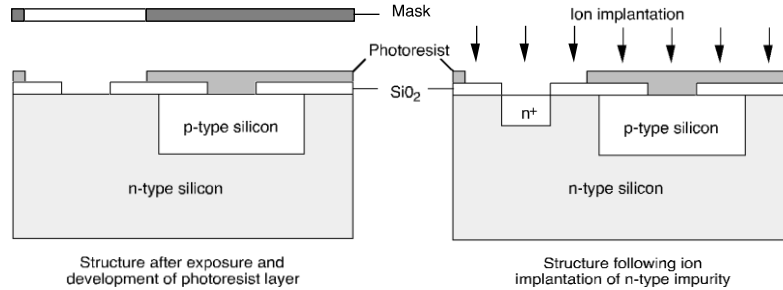

2.52

$$(a) N = 8\left(\frac{1}{8}\right) + 6\left(\frac{1}{2}\right) + 4(1) = 8 \text{ atoms}$$

$$(b) V = l^3 = (0.543 \times 10^{-9} \text{ m})^3 = (0.543 \times 10^{-7} \text{ cm})^3 = 1.60 \times 10^{-22} \text{ cm}^3$$

$$(c) D = \frac{8 \text{ atoms}}{1.60 \times 10^{-22} \text{ cm}^3} = 5.00 \times 10^{22} \frac{\text{atoms}}{\text{cm}^3}$$

$$(d) m = \left(2.33 \frac{\text{g}}{\text{cm}^3}\right) 1.60 \times 10^{-22} \text{ cm}^3 = 3.73 \times 10^{-22} \text{ g}$$

(e) From Table 2.2, silicon has ϵ mass of 28.086 protons.

$$m_p = \frac{3.73 \times 10^{-22} \text{ g}}{28.082(8) \text{ protons}} = 1.66 \times 10^{-24} \frac{\text{g}}{\text{proton}}$$

Yes, near the actual proton rest mass.