

***Solution Manual for Operations Management Processes and  
Supply Chains 10th Edition Krajewski Ritzman Malhotra  
0132807394 9780132807395***

*Full link download:*

*Test Bank:*

<https://testbankpack.com/p/test-bank-for-operations-management-processes-and-supply-chains-10th-edition-krajewski-ritzman-malhotra-0132807394-9780132807395/>

*Solution Manual:*

<https://testbankpack.com/p/solution-manual-for-operations-management-processes-and-supply-chains-10th-edition-krajewski-ritzman-malhotra-0132807394-9780132807395/>

## Chapter

# 2 Project Management

### DISCUSSION QUESTIONS

1. Software is an essential element for successful management of complex projects. It can provide information on completion performance of critical activities, highlight activities that need additional resources, and suggest the project duration that will minimize costs. However, whether projects are large or small, the people who manage them or perform the activities will ultimately determine the outcome of the project. The project manager must have the ability to coalesce a diverse group of people into an effective team. The organization of the firm must also be conducive to cross-functional inputs.
2. Slack in a project is determined by calculating the early start time (ES) and the latest start time (LS) for each activity. The ES time for an activity is found by moving forward through the project network from the Start activity along the longest time path to that activity. Using the project's targeted completion date, the LS time is found by moving backward through the project network from the Finish node along the longest path to that activity. The difference  $LS - ES$  determines the slack for that activity. Slack can also be calculated by taking the difference between the latest finish time (LF) and the earliest finish time (EF) for an activity. Managers need to know the slack for each activity because slack indicates how much the schedule for that activity can slip before the entire project is delayed. Activities with little or no slack need to be closely monitored. In addition, managers can move resources from activities enjoying sizeable slack to activities that have no slack or are falling behind schedule.
3. Risk is a measure of the probability and consequence of not reaching a project goal. There are four major sources of risk in a project: (1) Strategic fit, which reflects the synergy of the project to the firm's operations strategy. A lack of fit may cause myriad problems of resource allocation and managerial motivation. (2) If the project involves the introduction of a new service or product, competitor reactions, technological developments after the project has been initiated, and legal challenges brought on by unforeseen design consequences can all have a role in defining the success of the project. (3) The capability of the project team to tackle the specifications of the project play a major role in the success of the project. (4) There may be an operations risk introduced by poor information communication, poor design of the project network, or bad estimates for activity times.



**PROBLEMS**

1.

a. AON network diagram

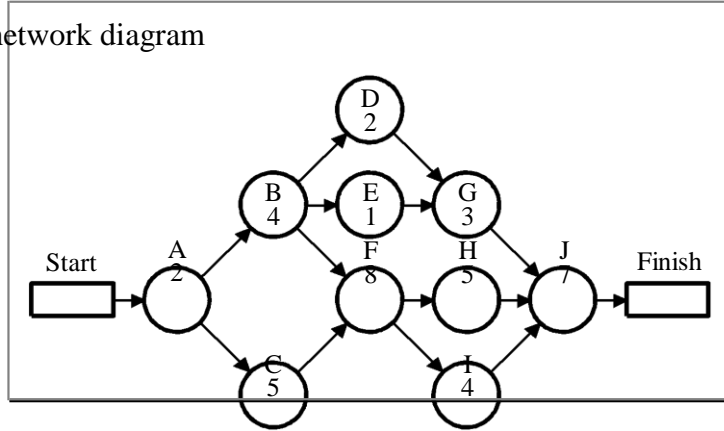

b. The critical path is A–C–F–H–J with a completion time of 27 days.

c.

Activity	Duration	Earliest Start	Latest Start	Earliest Finish	Latest Finish	Slack	On Critical Path?
A	2	0	0	2	2	0	Yes
B	4	2	3	6	7	1	No
C	5	2	2	7	7	0	Yes
D	2	6	15	8	17	9	No
E	1	6	16	7	17	10	No
F	8	7	7	15	15	0	Yes
G	3	8	17	11	20	9	No
H	5	15	15	20	20	0	Yes
I	4	15	16	19	20	1	No
J	7	20	20	27	27	0	Yes

2.

a. AON diagram

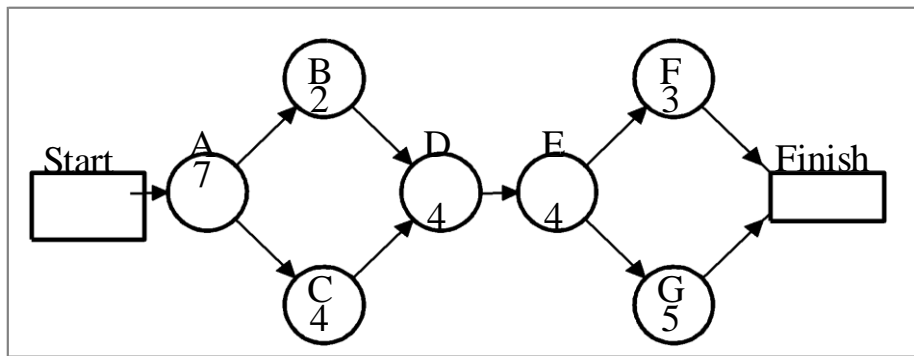

b. The critical path is A–C–D–E–G with a completion time of 24 days.

Activity	Duration	Earliest Start	Latest Start	Earliest Finish	Latest Finish	Slack	On Critical Path?
A	7	0	0	7	7	0	Yes
B	2	7	9	9	11	2	No
C	4	7	7	11	11	0	Yes
D	4	11	11	15	15	0	Yes
E	4	15	15	19	19	0	Yes
F	3	19	21	22	24	2	No
G	5	19	19	24	24	0	Yes

c. Activities B and F are the only ones to have slack.

3. Billing process.

a. AON diagram

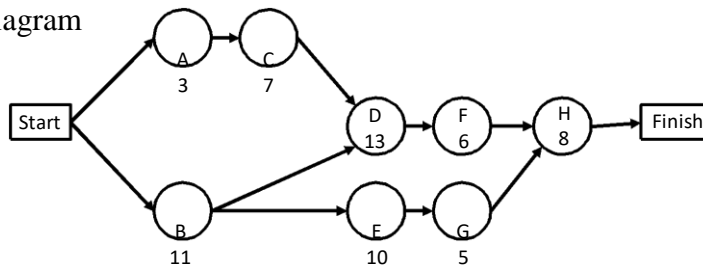

b. The critical path is B-D-F-H with a completion time of 38 weeks. The computation of slack is provided in the following output from *Project Management Solver* of OM Explorer.

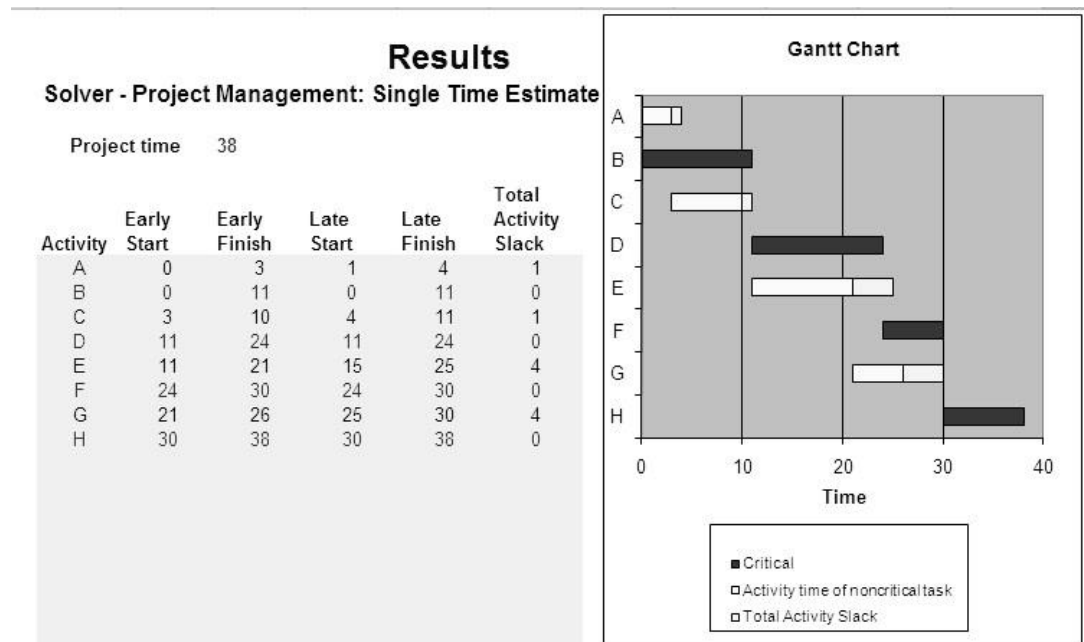

4.

a. AON diagram

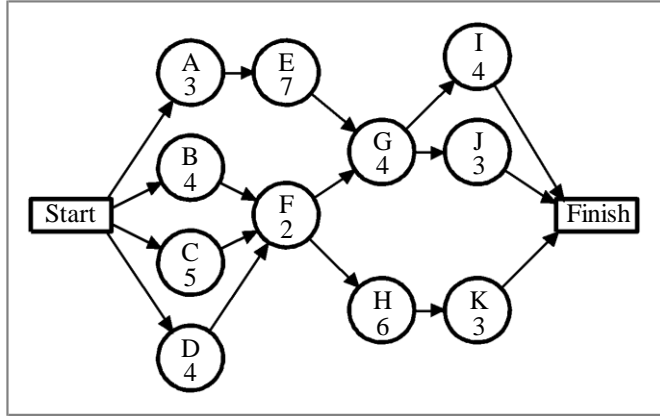

b. The critical path is A–E–G–I with a completion time of 18 days.

Activity	Duration	Earliest Start	Latest Start	Earliest Finish	Latest Finish	Slack	On Critical Path?
A	3	0	0	3	3	0	Yes
B	4	0	3	4	7	3	No
C	5	0	2	5	7	2	No
D	4	0	3	4	7	3	No
E	7	3	3	10	10	0	Yes
F	2	5	7	7	9	2	No
G	4	10	10	14	14	0	Yes
H	6	7	9	13	15	2	No
I	4	14	14	18	18	0	Yes
J	3	14	15	17	18	1	No
K	3	13	15	16	18	2	No

5.

a. The AON network is:

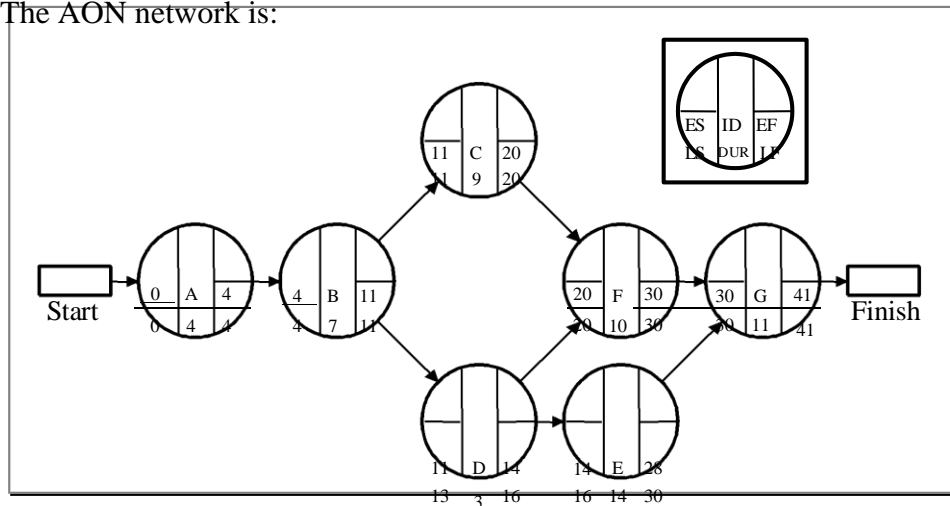

b. Activity slacks for the project:

Activity	Start		Finish		Slack	Critical Path?
	Earliest	Latest	Earliest	Latest		
A	0	0	4	4	0	Yes
B	4	4	11	11	0	Yes
C	11	11	20	20	0	Yes
D	11	13	14	16	2	No
E	14	16	28	30	2	No
F	20	20	30	30	0	Yes
G	30	30	41	41	0	Yes

Critical path is A–B–C–F–G, and the project completion date is week 41.

6. Crestview Bank.

a. The AON diagram is:

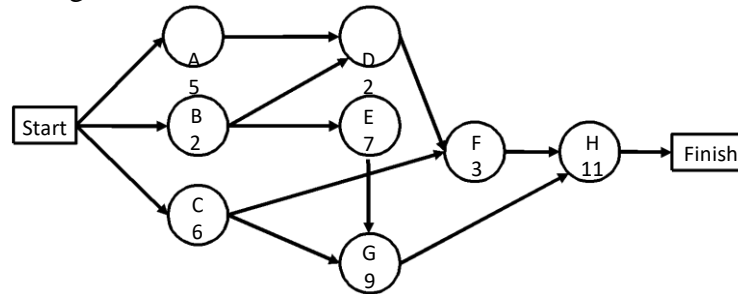

b. The critical path is B-E-G-H with a completion time of 29 weeks.

c. The computation of slack is provided in the following output from *Project Management Solver* of OM Explorer.

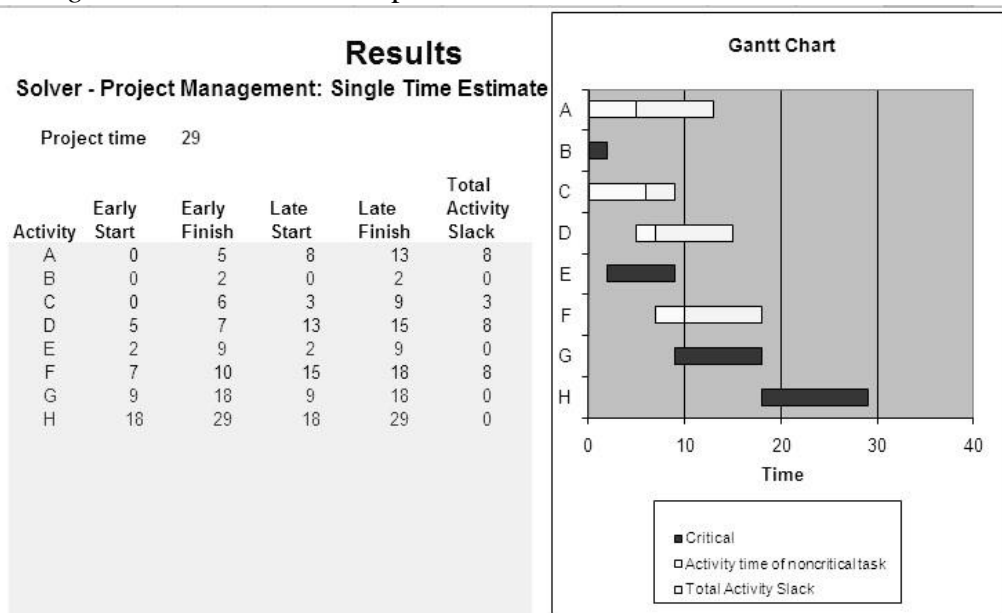

The slack for activity A = 13 – 5 = 8 weeks.

The slack for activity D = 15 – 7 = 8 weeks.

7. Web Ventures Inc.

Activity	Activity Statistics				
	Optimistic (a)	Most Likely (m)	Pessimistic (b)	Expected Time ( $t_e$ )	Variance ( $\sigma^2$ )
A	3	8	19	<b>9</b>	<b>7.11</b>
B	12	15	18	<b>15</b>	<b>1.00</b>
C	2	6	16	<b>7</b>	<b>5.44</b>
D	4	9	20	<b>10</b>	<b>7.11</b>
E	1	4	7	<b>4</b>	<b>1.00</b>

a.

$$t_eA = (3 + 4(8) + 19) / 6 = 54 / 6 = 9 \text{ days}$$

$$t_eB = (12 + 4(15) + 18) / 6 = 90 / 6 = 15 \text{ days}$$

$$t_eC = (2 + 4(6) + 16) / 6 = 42 / 6 = 7 \text{ days}$$

$$t_eD = (4 + 4(9) + 20) / 6 = 60 / 6 = 10 \text{ days}$$

$$t_eE = (1 + 4(4) + 7) / 6 = 24 / 6 = 4 \text{ days}$$

b.

$$\sigma^2A = ((19 - 3) / 6)^2 = 7.11$$

$$\sigma^2B = ((18 - 12) / 6)^2 = 1.00$$

$$\sigma^2C = ((16 - 2) / 6)^2 = 5.44$$

$$\sigma^2D = ((20 - 4) / 6)^2 = 7.11$$

$$\sigma^2E = ((7 - 1) / 6)^2 = 1.00$$

8.

a. The expected activity times (in days) are:

Activity	Optimistic	Most Likely	Pessimistic	$t_e$	$\sigma^2$
A	5	8	11	8.00	1.00
B	4	8	11	7.83	1.36
C	5	6	7	6.00	0.11
D	2	4	6	4.00	0.44
E	4	7	10	7.00	1.00

Path Total Expected Time



---

A-C	$8 + 6 = 14.00$
A-D-E	$8 + 4 + 7 = 19.00$
B-E	$7.83 + 7 = 14.83$

---

The critical path is A–D–E because it has the longest time duration. The expected completion time is 19 days.

$$b. z = \frac{T - T_E}{\sigma_P}$$

Where  $T = 21$  days,  $T_E = 19$  days, and the sum of the variances for critical path A–D–E is  $(1.00 + 0.44 + 1.00) = 2.44$ .

$$z = \frac{21 - 19}{\sqrt{2.44}} = \frac{2}{1.562} = 1.28$$

Assuming the normal distribution applies (which is questionable for a sample of three activities), we use the table for the normal probability distribution. Given  $z = 1.28$ , the probability that the project can be completed in 21 days is 0.8997, or about 90%.

- c. Because the normal distribution is symmetrical, the probability the project can be completed in 17 days is  $(1 - 0.8997) = 0.1003$ , or about 10%.

9. Solved Problem 2.

$$z = \frac{T - T_E}{\sigma_P}$$

Where  $T = 20$  weeks,  $T_E = (5.5 + 9.0 + 4.5) = 19$  weeks, and the sum of the variances for critical path B–F–G is  $(0.69 + 2.78 + 0.69) = 4.16$ .

Assuming the normal distribution applies, we use the table for the normal probability distribution. Given  $z = 0.49$ , the probability for activities B–F–G taking longer than 20 weeks is  $(1 - 0.6879)$ , or 31.21%.

10.

- a. The AON diagram is:

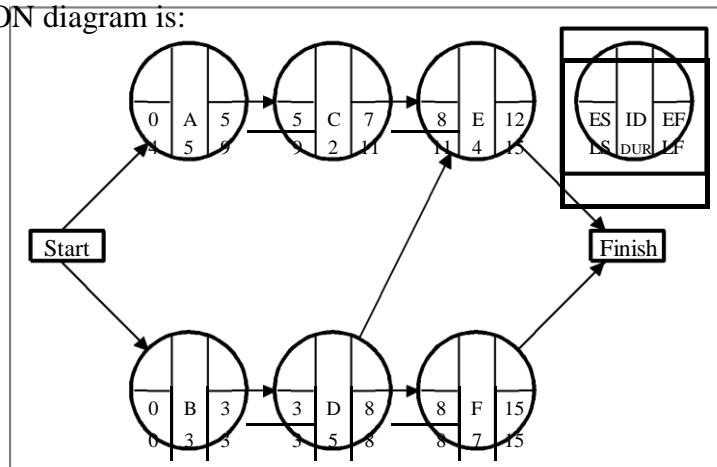

- b. Critical path is B–D–F. Expected duration of the project is 15 weeks.  
 c. Activity slacks for the project are:

Activity	Start		Finish		Slack	Critical Path?
	Earliest	Latest	Earliest	Latest		
A	0	4	5	9	4	No
B	0	0	3	3	0	Yes
C	5	9	7	11	4	No
D	3	3	8	8	0	Yes
E	8	11	12	15	3	No
F	8	8	15	15	0	Yes

11. Bluebird University.

Calculation of activity statistics (in days):

Project time		43.16667		Project standard deviation		2.939		Total Activity Slack
				Project variance		8.639		
Activity	Expected Time	Standard deviation	Variance	Early Start	Early Finish	Late Start	Late Finish	
A	6.83	0.50	0.25	0.00	6.83	0.00	6.83	0.00
B	8.33	1.00	1.00	0.00	8.33	2.33	10.67	2.33
C	4.00	0.33	0.11	0.00	4.00	16.67	20.67	16.67
D	17.33	2.33	5.44	6.83	24.17	6.83	24.17	0.00
E	10.00	0.67	0.44	8.33	18.33	10.67	20.67	2.33
F	4.00	0.33	0.11	18.33	22.33	20.67	24.67	2.33
G	7.50	0.83	0.69	24.17	31.67	24.17	31.67	0.00
H	7.00	0.67	0.44	22.33	29.33	24.67	31.67	2.33
I	11.50	1.50	2.25	31.67	43.17	31.67	43.17	0.00
J	4.00	0.00	0.00	31.67	35.67	39.17	43.17	7.50

The AON diagram is:

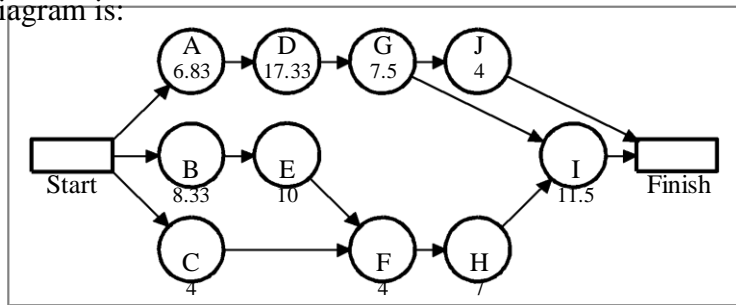

The critical path is A–D–G–I, and the expected completion time is 43.17 days.  $T = 47$  days,  $T_E = 43.17$  days, and the sum of the variances for the critical activities is:  $(0.25 + 5.44 + 0.69 + 2.25) = 8.63$ .

$$z = \frac{T - T_E}{\sigma_P} = \frac{47 - 43.17}{\sqrt{8.63}} = \frac{3.83}{2.94} = 1.30$$

Assuming the normal distribution applies, we use the table for the normal probability distribution. Given  $z = 1.30$ , the probability that activities A–D–G–I can be completed in 47 days or less is 0.9032.

12. AON Diagram for the environmental project:

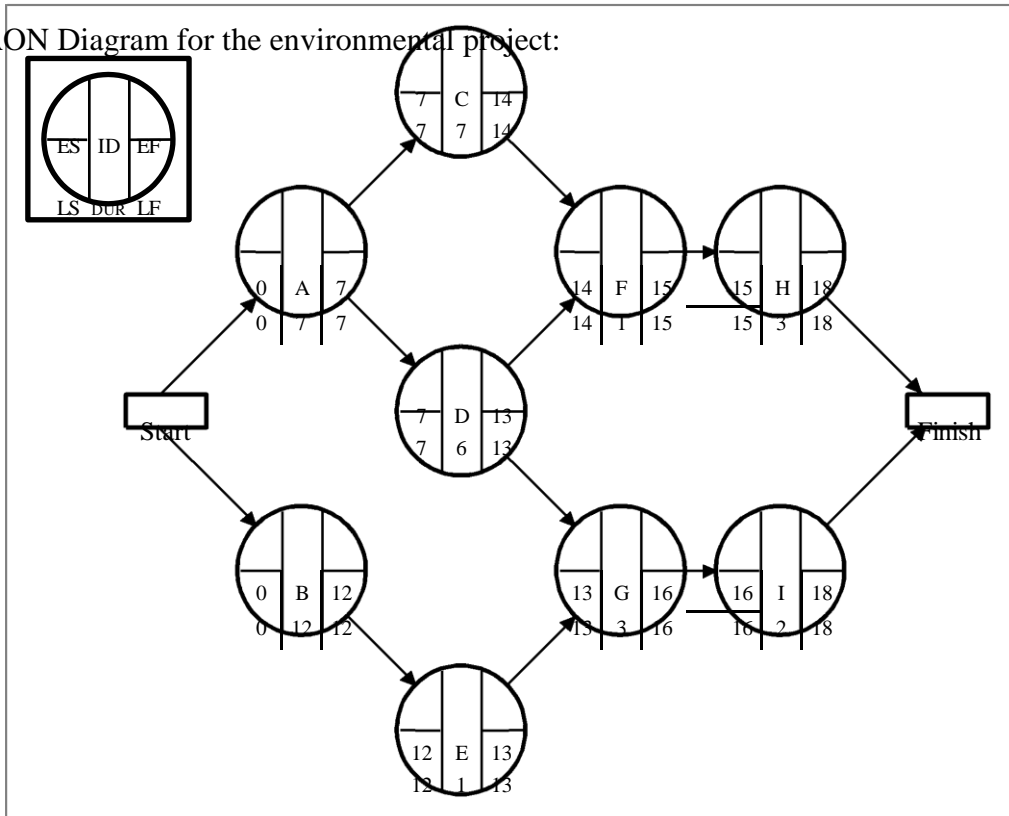

Trial	Crash Activity	Resulting Critical Path	Time Reduction (weeks)	Project Duration (weeks)	Crash Cost
0	—	A-C-F-H A-D-G-I B-E-G-I	—	18	0
1	A, G	A-C-F-H B-E-G-I	1	17	\$400
2	C, G	A-C-F-H A-D-F-H B-E-G-I	1	16	\$450
3	B, H	A-C-F-H A-D-F-H A-D-G-I B-E-G-I	1	15	\$600

Total crash costs = \$1450

To use OM Explorer for this problem, you need to modify the input data a little. The problem already gives the cost to crash per week for each activity. Since OM Explorer assumes it must calculate these values, multiply the number of weeks the activity can be crashed by the cost per week given in the problem

statement, e.g., for activity B,  $\$250(3) = \$750$ . The input sheet and the resulting crash schedule should look like the exhibits below.

### Solver - Crashing

Enter data in yellow shaded areas.

Indirect cost \$ 1,600 per week  
 Penalty cost \$ 1,200 per week after week 12

Activity	Normal Time	Normal Cost	Crash Time	Crash Cost	Precedence 1	Precedence 2	Precedence 3	Precedence 4
a	7	0	6	200				
b	12	0	9	750				
c	7	0	6	250	a			
d	6	0	5	300	a			
e	1	0	1	0	b			
f	1	0	1	0	c	d		
g	3	0	1	400	d	e		

#### CRASH SCHEDULE (Reduction in Time Periods)

Time	Period crash cost	Cumulative crash cost	Indirect costs	Direct costs	Penalty costs	Total costs	a	b	c	d	e	f	g	h	i
18			28,800	0	7,200	36,000									
17	400	400	27,200	0	6,000	33,600	1						1		
16	450	850	25,600	0	4,800	31,250	1		1				2		
15	600	1,450	24,000	0	3,600	29,050	1	1	1				2	1	

### 13. Advanced Tech

a. The AON diagram, with all task durations at Normal Time, for the project is:

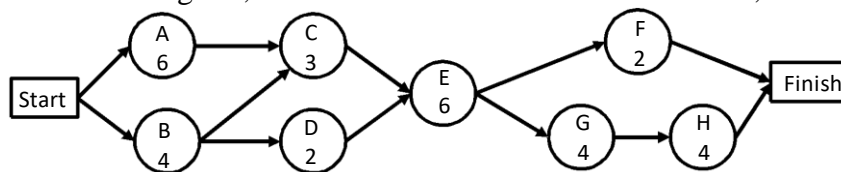

The critical path is A-C-E-G-H and the project duration is 23 days.

b. The computation of minimum-cost schedule is provided in the following output from POM for Windows software.

Project time	Period crash cost	Cumulative crash cost	Original costs	Indirect costs	Penalty costs	Total project cost
23	0	0	7500	6900	1350	15750
22	150	150	7500	6600	1200	15450
21	150	300	7500	6300	1050	15150
20	200	500	7500	6000	900	14900
19	200	700	7500	5700	750	14650
18	200	900	7500	5400	600	14400
17 Minimal cost schedule	300	1200	7500	5100	450	14250

The minimum-cost schedule is found at a project duration of 17 days and total project cost of \$14,250

- c. The activities crashed to arrive at the minimum-cost schedule is provided in the following output from POM for Windows software.

Project Management (PERT/CPM) Results							
	Normal time	Crash time	Normal Cost	Crash Cost	Crash cost/pd	Crash by	Crashing cost
Project	23					17	
A	6	5	1000	1200	200	1	200
B	4	2	800	2000	600	0	0
C	3	2	600	900	300	1	300
D	2	1	1500	2000	500	0	0
E	6	4	900	1200	150	2	300
F	2	1	1300	1400	100	0	0
G	4	4	900	900	0	0	0
H	4	2	500	900	200	2	400
Direct costs			7500				7500
Indirect costs			6900				5100
Penalty costs			1350				450
Crashing costs			0				1200
Total costs			15750			Min cost	14250

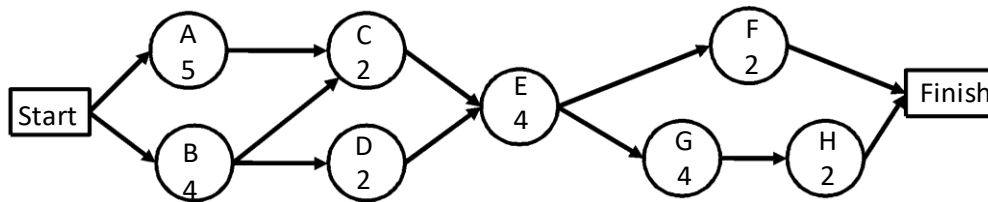

The critical path is A-C-E-G-H, and the project duration is 17 days.

14. Billing process.

- a. The critical path at the start is B-D-F at a duration of 18 weeks. We proceed as follows: (1) Crash Activity B to its maximum reduction because it is the cheapest activity on the critical path to crash per week and costs less than \$2,800, the sum of the indirect and penalty costs. The savings is \$3,600. The critical path is still B-D-F at a length of 16 weeks. (2) Reduce Activity D by 3 weeks for an additional savings of \$2,400. The critical path is still B-D-F at a duration of 13 weeks. No further reductions will lower total costs because the cost to crash the other activities (that is, Activity F) exceeds the potential reduction in indirect costs. Therefore, the minimum-cost schedule is 13 weeks.
- b. The “normal” direct cost is \$31,000, the “normal” indirect costs are \$28,800, the penalty costs are \$7,200, and the total for the normal schedule is \$67,000. The

cost for the schedule in part a is  $\$31,000 + \$8,000$  (crash costs) +  $\$20,800$  (indirect costs) +  $\$1,200$  (penalty) =  $\$61,000$ . The total savings is  $\$6,000$ .



15. Excello Corporation..

- a. The shortest project duration time would be 7 weeks (path B-D-F), using the crash times.
- b. AON diagram with all task durations at Normal Time

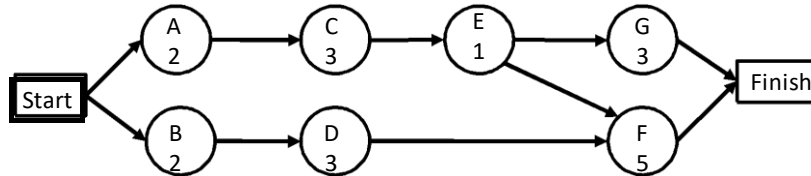

The critical path is A-C-E-F with a project completion time of 11 weeks. The computation of minimum-cost schedule is provided in the following output from POM for Windows software.

Project time	Period crash cost	Cumulative crash cost	Original costs	Indirect costs	Penalty costs	Total project cost	A	B	C	D	E	F	G
11	0	0	56000	165000	18000	239000							
10	3000	3000	56000	150000	9000	218000	1						
9	5000	8000	56000	135000	0	199000	1				1		
8	Minimal cost schedule	5000	13000	56000	120000	0	189000	1				2	
7	30000	43000	56000	105000	0	204000	1		1	1	2		

Since the “normal” project time is 11 weeks, the total normal “direct” cost is \$56,000. There would also be indirect costs of \$165,000 over the 11-week period. The penalty cost would be \$18,000. The grand total is \$239,000.

Likewise, the minimum-cost schedule for completing the project in 9 weeks has a total project cost of \$199,000.

- c. The crashing required to arrive at the minimum-cost schedule is provided in the following output from POM for Windows software.

	Normal time	Crash time	Normal Cost	Crash Cost	Crash cost/pd	Crash by	Crashing cost
Project	11					8	
A	2	1	7000	10000	3000	1	3000
B	2	2	3000	3000	0	0	0
C	3	1	12000	40000	14000	0	0
D	3	2	12000	28000	16000	0	0
E	1	1	8000	8000	0	0	0
F	5	3	5000	15000	5000	2	10000
G	3	2	9000	18000	9000	0	0
Direct costs			56000				56000
Indirect costs			165000				120000
Penalty costs			18000				0
Crashing costs			0				13000
Total costs			239000			Min cost	189000

The minimum-cost schedule would take 8 weeks. This can be found in the following way: (1) the starting critical path is A-C-E-F at 11 weeks. Since Activity A is the cheapest to crash per week, crash it one week for an additional cost of \$3000. The savings is \$15,000 (indirect costs) + \$9,000 (penalty costs) -

\$3,000 = \$21,000. The project duration is now 10 weeks. (2) Since Activity A cannot be crashed further, the next cheapest activity to crash that is on the critical path is Activity F. Crash F for its maximum of two weeks at an

additional cost of \$10,000. The savings would be \$30,000 (indirect costs) + \$18,000 (penalty costs) - \$10,000 = \$38,000.

The critical path is now 8 weeks in duration. Since the penalty costs are zero for further reductions, there are no other options to reduce the project time that are less costly than the indirect costs per week. Therefore, we stop.

16. Pet Paradise

- a. Calculation of the activity statistics is provided in the following output from POM for Windows software:

	Expected Time	Early Start	Early Finish	Late Start	Late Finish	Slack	Variance
Project	17						2.78
A	3.17	0	3.17	6.83	10	6.83	.69
B	9	0	9	1	10	1	1
C	9	0	9	0	9	0	2.78
D	3	3.17	6.17	10	13	6.83	.11
E	4	9	13	10	14	1	2.78
F	5	9	14	9	14	0	0
G	1	6.17	7.17	13	14	6.83	0
H	3	14	17	14	17	0	0

The AON diagram for the hiring project is:

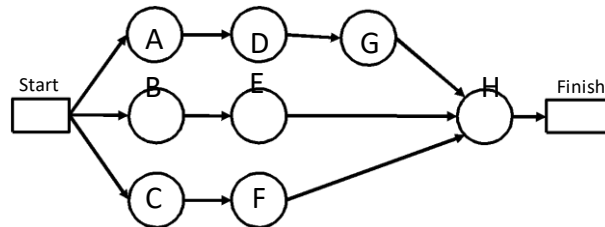

The critical path is C-F-H with an expected project completion time of 17 weeks.

b. 
$$z = \frac{T - T_E}{\sqrt{\sigma^2}} = \frac{14 - 17}{\sqrt{2.78}} = -1.799$$

Using the normal distribution table, the probability of project completion within 14 weeks is (1-.9641=.0359) or a 3.6% chance.

17. An AON diagram using the Alternative 1 (or “normal”) times follows.

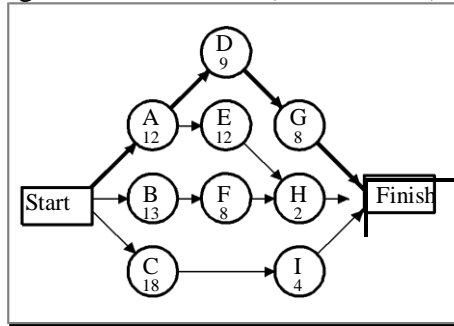

The critical path is A–D–G, and the project duration is 29 days.  
Direct cost and time data:

Activity	Crash Cost/Day	Maximum Crash Time (days)
A	\$600.00	1
B	112.50	4
C	750.00	2
D	250.00	4
E	225.00	2
F	350.00	1
G	200.00	2
H	200.00	1
I	900.00	2

Cost analysis for the project:

Trial	Crash Activity	Resulting Critical Path	Time Reduction (weeks)	Project Duration (weeks)	Crash Cost
0	—	A–D–G	—	29	—
1	G	A–D–G	2	27	400
2	D	A–D–G A–E–H	1	26	250
3	D, H	A–D–G A–E–H	1	25	450

The total cost for this project is:  
\$13,050 + \$400 + \$250 + \$450 = \$14,150.00

The activity times with crashing are:

A: 12                      B: 13                      C: 18                      D: 7                      E: 12  
F: 8                          G: 6                          H: 1                      I: 4

18. Sculptures International

a. The AON diagram for this project is:

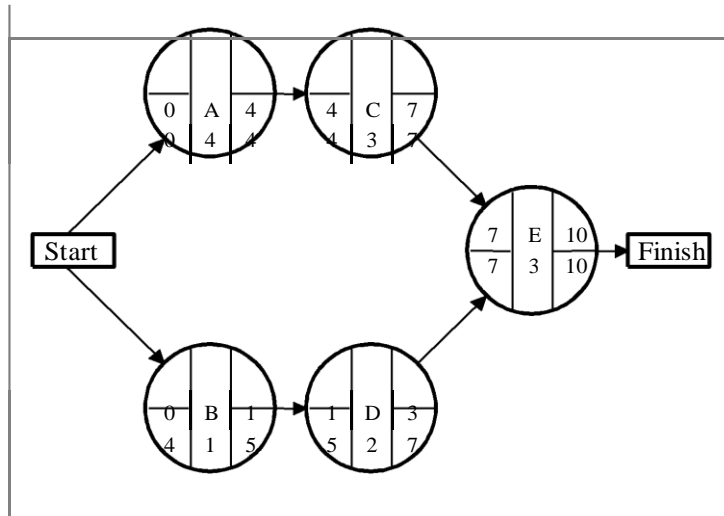

b. The critical path is A–C–E, and the project duration is 10 days.

c.

Activity	Activity Slack
A	0
B	$5 - 1 = 4$
C	0
D	$7 - 3 = 4$
E	0

19. Reliable Garage

a. The AON diagram is:

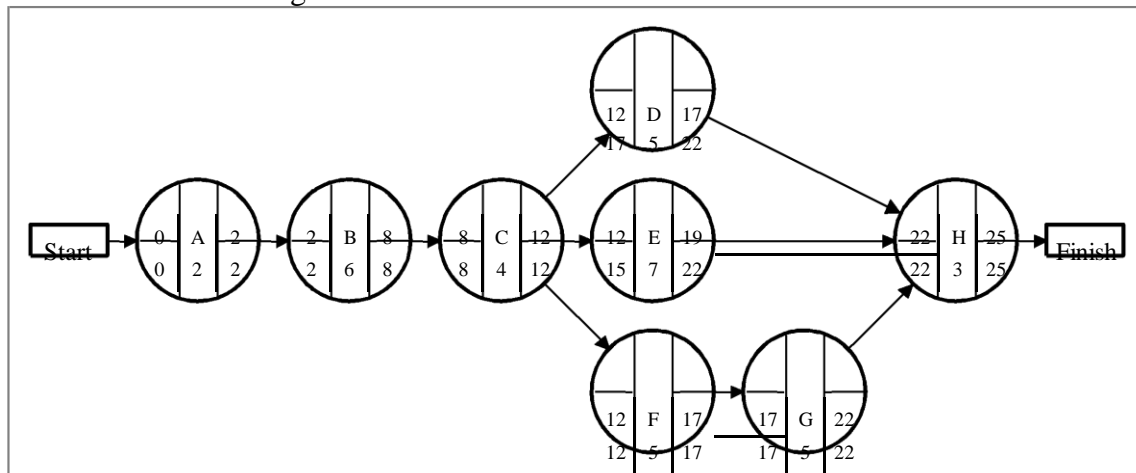

b. Critical Path is A–B–C–F–G–H, and the duration is 25 days.

c.

Activity	Activity Slack
A	0
B	0
C	0
D	$22 - 17 = 5$
E	$22 - 19 = 3$
F	0
G	0
H	0

20.

a. The AON diagram is shown below.

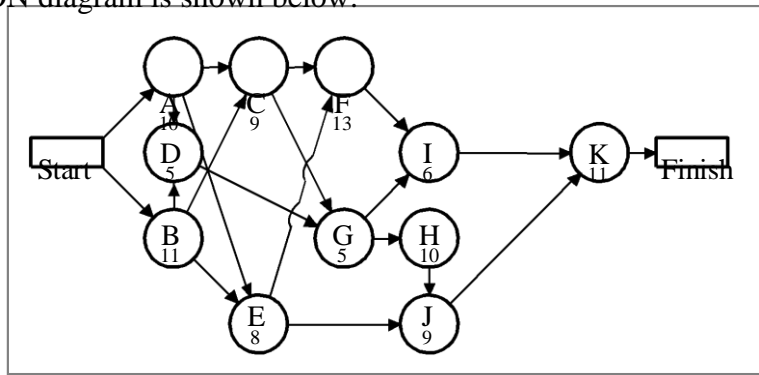

b. The critical path is B–C–G–H–J–K, and the expected project duration is 55 days.

21. Good Public Relations.

a. Calculation of the activity statistics:

Activity	Expected Time	Standard deviation	Variance	Project standard deviation		Project variance		Total Activity Slack
				Early Start	Early Finish	Late Start	Late Finish	
A	10.00	0.67	0.44	0.00	10.00	0.00	10.00	0.00
B	9.00	2.00	4.00	0.00	9.00	9.00	18.00	9.00
C	8.00	0.33	0.11	0.00	8.00	2.00	10.00	2.00
D	2.00	0.33	0.11	9.00	11.00	18.00	20.00	9.00
E	10.00	0.67	0.44	10.00	20.00	10.00	20.00	0.00
F	6.00	0.33	0.11	20.00	26.00	20.00	26.00	0.00
G	3.00	0.67	0.44	20.00	23.00	23.00	26.00	3.00
H	5.00	1.00	1.00	26.00	31.00	26.00	31.00	0.00
I	4.00	0.67	0.44	23.00	27.00	32.33	36.33	9.33
J	5.33	0.67	0.44	31.00	36.33	31.00	36.33	0.00
K	2.00	0.00	0.00	31.00	33.00	34.33	36.33	3.33

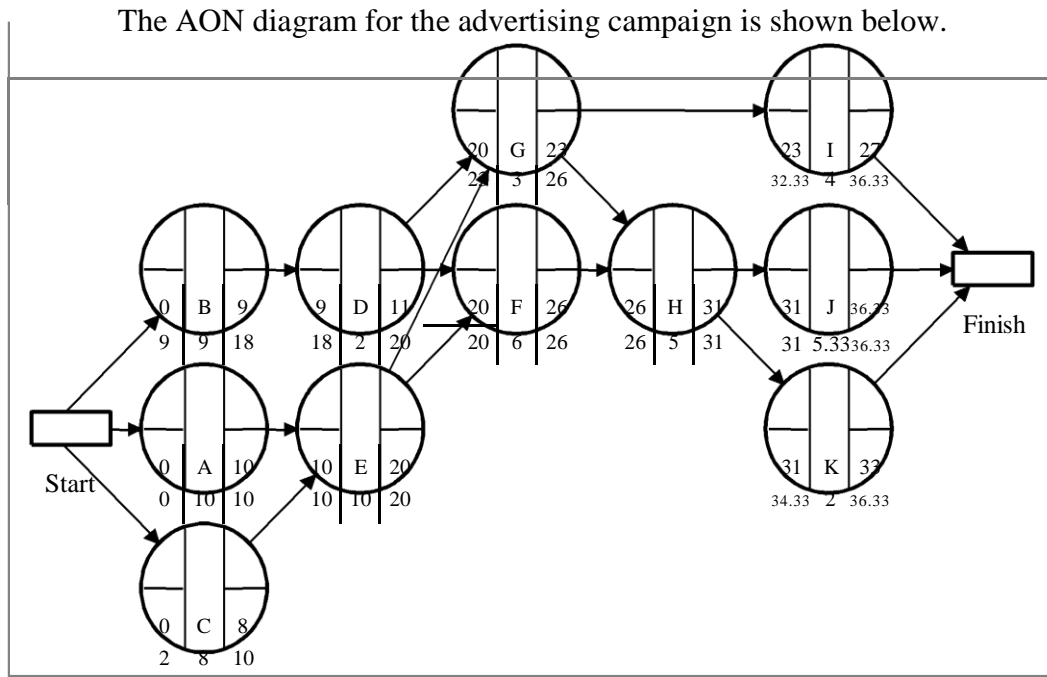

The critical path is A–E–F–H–J, the expected project duration is 36.33 days, and the sum of the variances of the critical path activities is  $(0.44 + 0.44 + 0.11 + 1.00 + 0.44) = 2.43$

b. 
$$z = \frac{T - T_E}{\sigma_P} = \frac{38 - 36.33}{\sqrt{2.43}} = \frac{1.67}{1.56} = 1.07$$

The probability that the project will take more than 38 days is  $1 - 0.8577$  or  $0.1423$

c. The path A–E–G–H–J has a duration of 33.33 weeks with variance of 2.76.

Therefore, 
$$z = \frac{T - T_E}{\sigma_P} = \frac{38 - 33.33}{\sqrt{2.76}} = 2.81$$

The probability that the path A–E–G–H–J exceeds 38 weeks is  $1 - 0.9975$ , or  $0.0025$ .

22. The AON diagram for the office renovation project is below.

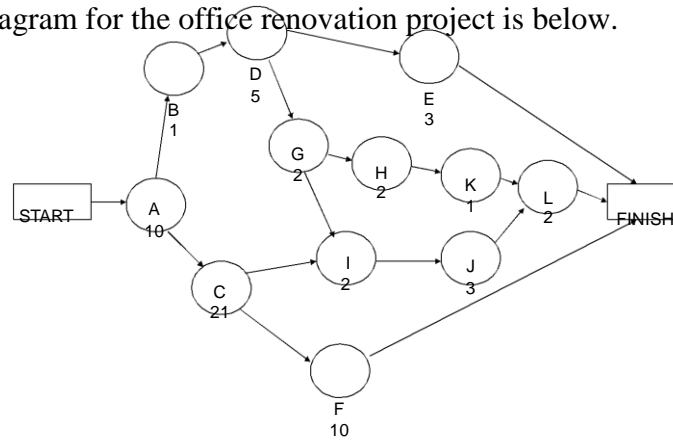

The calculations of the time statistics are contained in the following table.

Activity	Optimistic	Most Likely	Pessimistic	Expected Time	Variance
START	0	0	0	-----	-----
A	6	10	14	10	1.78
B	0	1	2	1	0.11
C	16	20	30	21	5.44
D	3	5	7	5	0.44
E	2	3	4	3	0.11
F	7	10	13	10	1.00
G	1	2	3	2	0.11
H	0	2	4	2	0.44
I	2	2	2	2	0.00
J	2	3	4	3	0.11
K	0	1	2	1	0.11
L	1	2	3	2	0.11
FINISH	0	0	0	-----	-----

a. The critical path is A – C - F at 41 days.

$$\text{Standard Deviation} = \text{SQRT} (1.78 + 5.44 + 1.00) = 2.867.$$

$z = (41 - 39) / 2.867 = 0.698$ , which can be rounded to 0.70. From the normal tables,  $P(z) = 0.758$ . Therefore,  $P(T < 39 \text{ days}) = 1.000 - 0.758 = 24 \text{ percent}$ .

b. We want to find the project completion time so that the probability of completion is 90 percent. The  $z$  value for 90 percent is 1.28. Consequently,

$$(T - 41) / 2.867 = 1.28$$

$$T = 1.28 (2.867) + 41$$

$$T = 44.7, \text{ or about } 45 \text{ days.}$$



23. The AON diagram for the community center project is below.

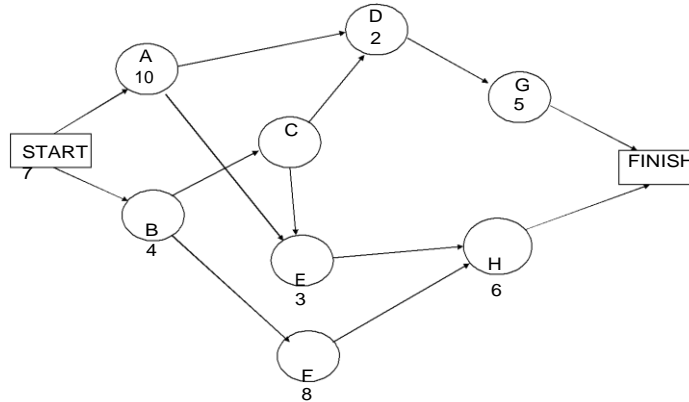

The crashing data are given in the following table.

Activity	Normal		Crash		Maximum Reduction	\$ per Day
	Time (days)	Cost (\$)	Time (days)	Cost (\$)		
START	0	0	0	0	-----	-----
A	10	50	8	150	2	50
B	4	40	2	200	2	80
C	7	70	6	160	1	90
D	2	20	1	50	1	30
E	3	30	NONE	NONE	NONE	NONE
F	8	80	5	290	3	70
G	5	50	4	180	1	130
H	6	60	3	180	3	40
FINISH	0	0	0	0	-----	-----

- a. The critical path is B – C - E – H at 20 days.
- b. STAGE 1

Critical path is B – C – E – H at 20 days. Crash H for 2 days. You are stopped by path B – C – D – G.  
 Savings:  $2(50 + 40) - 2(40) = \$100$ .

**STAGE 2**

There are two critical paths: B – C – E – H and B- C – D – G at 18 days. Crash H and D each for 1 day. Savings:  $1(50 + 40) - 1(40 + 30) = \$20$ .

**STAGE 3**

There are two critical paths: B – C – E – H and B – C – D – G at 17 days. Crash B 1 day. You are constrained by a new path, A – E – H and A – D – G. Savings:  $1(50 + 40) - 1(80) = \$10$ .

STAGE 4

There are now four critical paths: B – C – E – H, B – C – D – G, A – E – H and A – D – G each at 16 days. The only option is to crash both A and B; however the total cost of \$130 per day exceeds the potential savings. Therefore, stop.

Total Cost = 16(50) + 2(40) + 400 + 80 + 70 + 80 = \$1,510.

24.

a. AON diagram for the fund-raising project

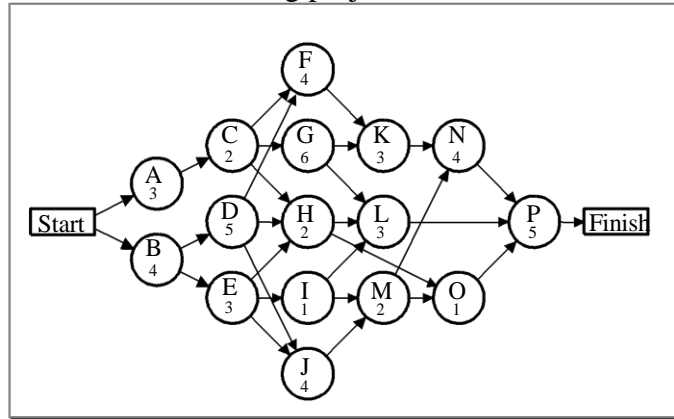

Activity slacks for the project:

Results					
Solver - Project Budgeting					
Project time		25		Project Budget \$2,125	
	Early	Early	Late	Late	Total Activity
Activity	Start	Finish	Start	Finish	Slack
A	0	3	2	5	2
B	0	4	0	4	0
C	3	5	5	7	2
D	4	9	4	9	0
E	4	7	7	10	3
F	9	13	9	13	0
G	5	11	7	13	2
H	9	11	15	17	6
I	7	8	13	14	6
J	9	13	10	14	1
K	13	16	13	16	0
L	11	14	17	20	6
M	13	15	14	16	1
N	16	20	16	20	0
O	15	16	19	20	4
P	20	25	20	25	0

The critical path is B–D–F–K–N–P, and the expected completion time is 25 days.

b. Project cost with the earliest start time for each activity:

**Project time 25 Project Budget \$ 2,125**

Period	Total	A	B	C	D	E	F	G	H	I	J	K	L	M	N	O	P
1	70.83	33.33	37.50														
2	70.83	33.33	37.50														
3	70.83	33.33	37.50														
4	100.00		37.50	62.50													
5	147.50			62.50	35.00	50.00											
6	97.50				35.00	50.00	12.50										
7	97.50				35.00	50.00	12.50										
8	147.50				35.00		12.50	100.00									
9	47.50				35.00		12.50										
10	106.25						50.00	12.50	25.00		18.75						
11	106.25						50.00	12.50	25.00		18.75						
12	118.75						50.00				18.75	50.00					
13	118.75						50.00				18.75	50.00					
14	150.00										50.00	50.00	50.00				
15	100.00										50.00		50.00				
16	250.00										50.00					200.00	
17	43.75														43.75		
18	43.75														43.75		
19	43.75														43.75		
20	43.75														43.75		
21	30.00																30.00
22	30.00																30.00
23	30.00																30.00
24	30.00																30.00
25	30.00																30.00

Project cost with the latest start times for each activity:

Project time 25 Project Budget \$ 2,125

Period	Total	A	B	C	D	E	F	G	H	I	J	K	L	M	N	O	P
1	37.50		37.50														
2	37.50		37.50														
3	70.83	33.33	37.50														
4	70.83	33.33	37.50														
5	68.33	33.33			35.00												
6	97.50			62.50	35.00												
7	97.50			62.50	35.00												
8	97.50				35.00	50.00		12.50									
9	97.50				35.00	50.00		12.50									
10	112.50					50.00	50.00	12.50									
11	81.25						50.00	12.50			18.75						
12	81.25						50.00	12.50			18.75						
13	81.25						50.00	12.50			18.75						
14	168.75								100.00	18.75	50.00						
15	100.00										50.00		50.00				
16	125.00								25.00		50.00		50.00				
17	68.75								25.00						43.75		
18	93.75												50.00		43.75		
19	93.75												50.00		43.75		
20	293.75												50.00		43.75	200.00	
21	30.00																30.00
22	30.00																30.00
23	30.00																30.00
24	30.00																30.00
25	30.00																30.00

Cost by day is plotted for Early Start and Late Start Schedules.

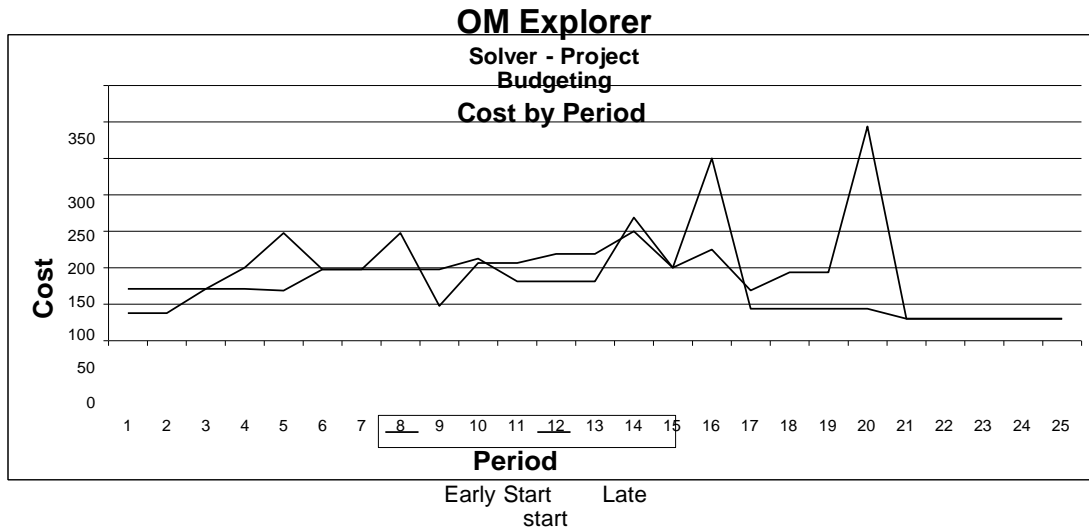

These two plots indicate the patterns of cash flow associated with the two different project schedules. Management can select the schedule that fits better with its financial status. Notice that the latest start dates delay cash flow requirements to the later time periods of the project.

25. The AON diagram for the software installation project is below.

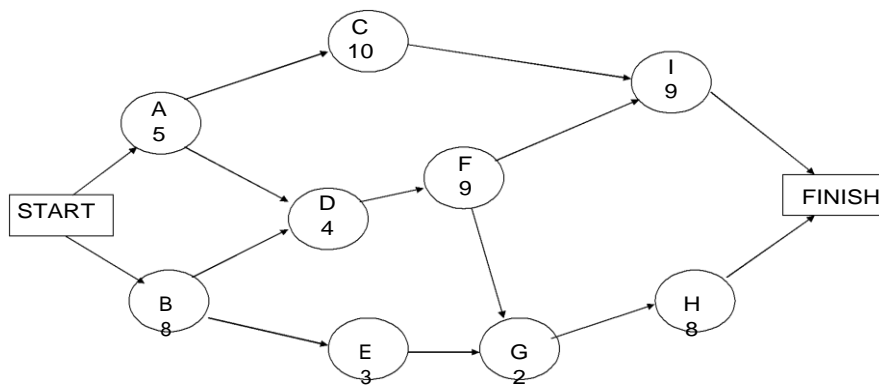

The crashing data are given in the following table.

Activity	Normal Time	Normal Cost	Crash Time	Crash Cost	Max reduction	\$ per Week
A	5	\$2,000	3	\$4,000	2	1,000
B	8	\$5,000	7	\$8,000	1	3,000
C	10	\$10,000	8	\$12,000	2	1,000
D	4	\$3,000	3	\$7,000	1	4,000
E	3	\$4,000	2	\$5,000	1	1,000
F	9	\$8,000	6	\$14,000	3	2,000
G	2	\$2,000	2	\$2,000	NONE	NONE
H	8	\$6,000	5	\$9,000	3	1,000
I	9	\$7,000	7	\$15,000	2	4,000

a. STAGE 1

The critical path is B – D – F – G – H at 31 weeks. Crash H by 1 week because you are constrained by path B – D – F – I. Savings:  $1(3,500) - 1(1,000) = \$2,500$ .

STAGE 2

There are two critical paths: B – D – F – G – H and B – D – F – I at 30 weeks. Crash F for 3 weeks. Savings:  $3(3,500) - 3(2,000) = \$4,500$ .

STAGE 3

There are still two critical paths: B – D – F – G – H and B – D – F – I at 27 weeks. Crash B for 1 week. Savings:  $1(3,500) - 1(3,000) = \$500$ .

STAGE 4

There are still two critical paths: B – D – F – G – H and B – D – F – I at 26 weeks. All options cost more than the potential savings. Therefore, stop. Your target completion week is week 26.

b. Total Savings =  $\$2,500 + \$4,500 + \$500 = \$7,500$ .

26. The AON diagram for the project is below.

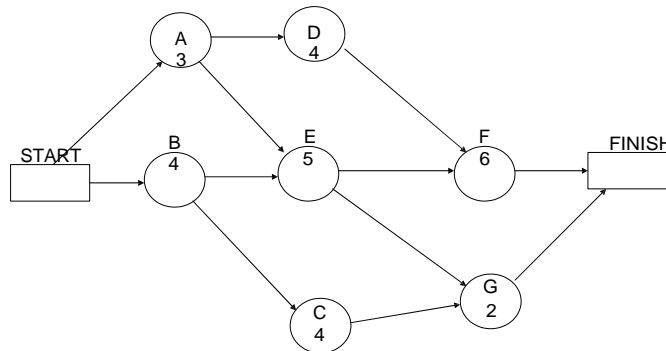

Additional data for the project are contained in the following table.

Activity	Time (weeks)	Early Start	Late Start	Slack
START	0	0	0	0
A	3	0	1	1
B	4	0	0	0
C	4	4	9	5
D	4	3	5	2
E	5	4	4	0
F	6	9	9	0
G	2	9	13	4
FINISH	0	15	15	0

- The critical path is B – E – F. The project will be finished in week 15.
- Activity G is on a path with 4 weeks of slack; however each week Employee A spends at Activity F, F’s time goes down a week while G’s goes up a week. Consequently, assigning Employee A to Activity F for 2 weeks will result in two critical paths: B – E – F at 13 weeks and B – E - G at 13 weeks. Assigning Employee A to Activity F for any more time than that will actually increase the project’s time from the low of 13 weeks.



## CASE: THE PERT MUSTANG \*

### A. Synopsis

The owner of the Roberts' Auto Sales and Service Company is interested in restoring a 1965 Shelby Mustang GT 350 for advertising a new restoration business she wants to start. The restoration project involves 22 activities and needs to be completed in 45 days so that the car can be displayed in an auto show. The owner wants an assessment of how the restoration business fits with the other businesses the company engages in, a report on the activities that need to be completed and their interrelationships, an assessment of whether the project can be completed on time, and a budget.

### B. Purpose

This case provides enough data for the student to develop a PERT/CPM network for a project involving 22 activities. With this case, the class can:

- Discuss how well a new market segment can be satisfied with an existing operation.
- Gain experience in identifying the relationships between activities in a large project.
- Relate cost to the development of a project.

### C. Analysis

1. The restoration business, although entailing much of the skills and resources needed for the other market segments the company serves, needs to be evaluated carefully before making a commitment. Currently, the company has three car dealerships, two auto parts stores, one body/paint shop, and one auto storage yard. These operations would be useful for the restoration business. However, the nature of the markets served by these operations is not made explicit in the case. Some questions come to mind:
  - a. Are the auto parts stores equipped to provide customers with “one-of-a-kind” parts? Restoration parts are hard to find and require access and familiarity with different information systems.
  - b. Does the body/paint shop have the ability to do custom, high-quality work, with restoration of rusty parts, or is it a high-volume operation with minimal capability to restore *any* car to its original condition?
  - c. Does the machine shop have the capability to machine one part at a time to unique specifications if the restoration part cannot be purchased from a supplier?

---

\* This case was prepared by Dr. Sue Perrott Siferd, Arizona State University, as a basis for classroom discussion (Updated September, 2007).

- d. How useful will the salvage yard be for the restoration business? There must be a broad mix of vintage age autos in the yard in order to support the new business.

The competitive priorities for the restoration business most likely will be top quality and customization in a low-volume environment. It would seem that these competitive priorities could conflict with other market segments the company serves.

2. The project activities and the precedence relationships are given in Exhibit TN.1.
3. A PERT/CPM diagram is shown in Exhibit TN.2. The latest finish data are set for 45 days from present, which would be the day before the car must be in the show. The critical path is A–B–T–V, and the expected project duration is 41 days. The slack of each event along the critical path is 4 days, suggesting no problem in completing the project on time.
4. A project budget is shown in Exhibit TN.3. The project will meet the goal of staying below \$70,000.

A cash-flow report is shown in Exhibit TN.4. It is aggregated by weekly time periods. Activities B, C, and D are assumed to be paid when the item is received (on its early finish time). We assume that if an activity is scheduled to start during a week, the total cost is prorated for that week and following weeks. If MS Project is used for this analysis, the calendar date the students use for the start of the project may affect the weeks in which certain costs may accrue. Also, MS Project assumes a five-day workweek as a default. From Exhibit TN.4 it appears that there is a cash flow problem in week 2 because the cash required exceeds \$3,600. To resolve the problem, use the activity slack that is available and schedule one or more activities to start later than their earliest start times. For example, Activity D, receive carburetor and oil pump, has slack of 16 days (see Exhibit TN.2). Activity D could be scheduled to start in Week 3 so that it is completed in Week 4, thereby pushing the payment to Week 4. Note that Week 4 would now have \$3,550 in cash requirements, just below the constraint of \$3,600.

#### D. Recommendations

The owner should:

1. Carefully evaluate the potential conflicts of competitive priorities for the new restoration business.
2. Monitor the critical path of A–B–T–V, although there is slack.
3. Monitor the budget even though there should be ample room for unexpected contingencies.

**E. Teaching Suggestions**

This case should be an overnight assignment so that the students have the opportunity to think through the construction of the PERT/CPM diagram. This is not a difficult assignment, even though there are 22 activities. If used for discussion in class, it should be discussed after the PERT/CPM approach has been addressed in a previous class. Alternatively, the case could be used as a written assignment with no debriefing during class.

The discussion should begin with the potential conflicts with competitive priorities so that the class understands the strategic implications of the new restoration business. There is not enough information in the case to make a definitive conclusion, so the emphasis should be on the potential for conflicts and the need to do some serious exploration.

The discussion can then turn to the network diagram and the conclusions. See Exhibits TN.2 and TN.3 for suggestions.

**F. Board Plan**

Unique Tasks for Restoration Business	Competitive Priorities
Find parts no longer made	Top Quality
Manufacture unique parts	Customization
Low volumes	
Custom body work	
Custom paint work	
New information system	

Task	Time	Immediate Predecessors
A Order all needed material and parts	2 days	None
B Receive upholstery material	30 days	A
C Receive windshield	10 days	A
D Receive carburetor and oil pump	7 days	A
E Remove chrome from body	1 day	None
F Remove body from frame	1 day	E
G Get fenders repaired	4 days	F
H Repair the doors, trunk, and hood	6 days	F
I Pull engine from chassis	1 day	F
J Remove rust from frame	3 days	I
K Have valves reground in engine	5 days	I
L Replace carburetor and oil pump	1 day	D, I
M Get the chrome parts rechromed	3 days	E
N Reinstall engine	1 day	K, L
O Put doors, hood, and trunk back on frame	1 day	H, J
P Get transmission rebuilt and replace brake	4 days	N, O
Q Replace windshield	1 day	C
R Put fenders back on	1 day	G, P
S Get car painted	4 days	Q, R
T Reupholster interior of car	7 days	B, S
U Put chrome back on	1 day	M, S
V Pull car to Studebaker show in Springfield, Missouri	2 days	T, U

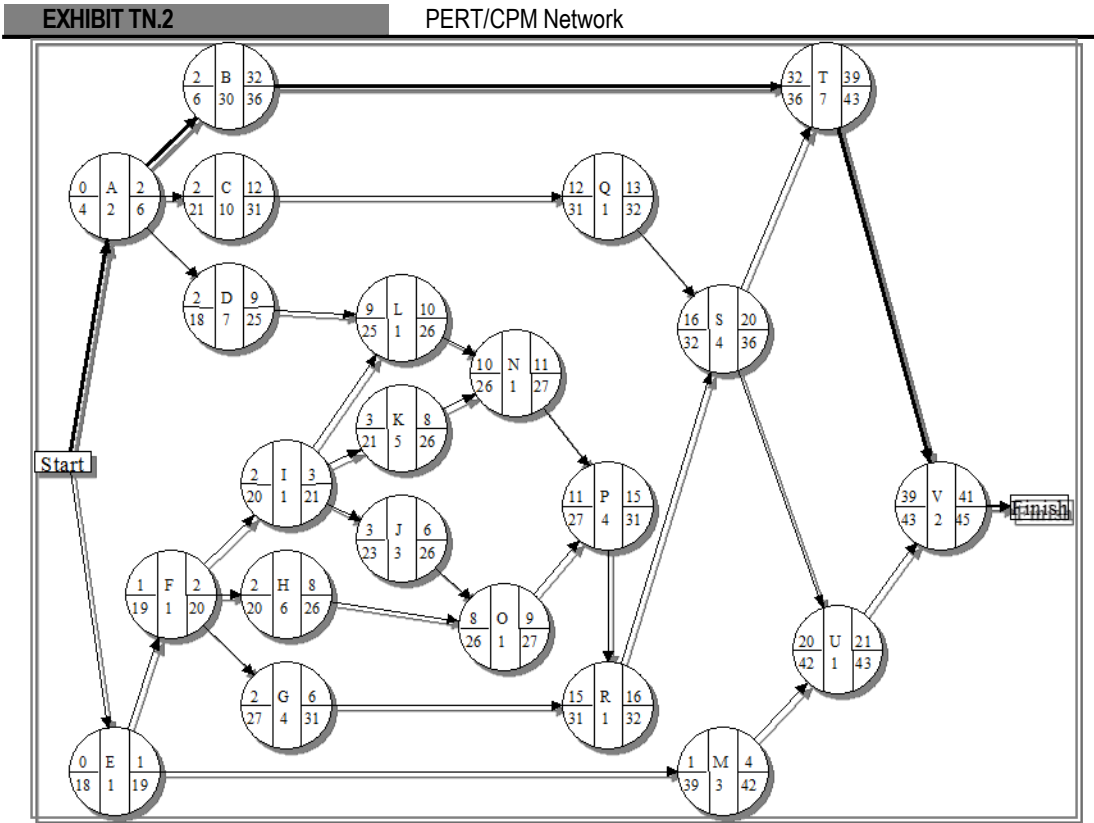

**EXHIBIT TN.3** Project Budget for The PERT Mustang

Task	Estimated Cost
A	\$100
B	2,100
C	800
D	1,750
E	200
F	300
G	1,000
H	1,500
I	200
J	900
K	1,000
L	200
M	210
N	200
O	240
P	2,000
Q	100
R	100
S	1,700
T	2,400
U	100
V	1,000
<b>Total Cost</b>	<b>\$18,100</b>

**EXHIBIT TN.4**

**Cash Flow Report for The Pert Mustang**

Based on 5-day weeks

		1	2	3	4	5	6	7	8	9	Total
Start											
A	Order needed material and parts	\$100									\$100
B	Receive upholstery material for seat covers							\$2,100			\$2,100
C	Receive windshield			\$800							\$800
D	Receive carburetor and oil pump		\$1,750								\$1,750
E	Remove chrome from body	\$200									\$200
F	Remove body from frame	\$300									\$300
G	Fenders repaired by body shop	\$750	\$250								\$1,000
H	Repair doors, trunk, hood	\$750	\$750								\$1,500
I	Pull engine from chassis	\$200									\$200
J	Remove rust from frame	\$600	\$300								\$900
K	Regrind engine valves	\$400	\$600								\$1,000
L	Replace carburetor and oil pump		\$200								\$200
M	Rechrome the chrome parts	\$210									\$210
N	Reinstall engine			\$200							\$200
O	Put doors, hood, and trunk on frame		\$240								\$240
P	Rebuild transmission and replace brakes			\$2,000							\$2,000
Q	Replace windshield			\$100							\$100
R	Put fenders back on				\$100						\$100
S	Paint car				\$1,700						\$1,700
T	Reupholster interior							\$1,029	\$1,371		\$2,400
U	Put chrome back on					\$100					\$100
V	Pull car to Studebaker show								\$500	\$500	\$1,000
Finish											
Total		\$3,510	\$4,090	\$3,100	\$1,800	\$100	\$0	\$3,129	\$1,871	\$500	\$18,100