

**Solution Manual for Principles of Heat Transfer 8th Edition Kreith
Manglik 1305387104 9781305387102**

Full link download:

<https://testbankpack.com/p/solution-manual-for-principles-of-heat-transfer-8th-edition-kreith-manglik-1305387104-9781305387102/>

Chapter 2

STEADY STATE CONDUCTION

PROBLEM 2.1

A plane wall, 7.5 cm thick, generates heat internally at the rate of 10^5 W/m^3 . One side of the wall is insulated, and the other side is exposed to an environment at 90°C . The convection heat transfer coefficient between the wall and the environment is $500 \text{ W/(m}^2 \text{ K)}$. If the thermal conductivity of the wall is 12 W/(m K) , calculate the maximum temperature in the wall.

GIVEN

- Plane wall with internal heat generation
- Thickness (L) = 7.5 cm = 0.075 m
- Internal heat generation rate (\dot{q}_G) = 10^5 W/m^3
- One side is insulated
- Ambient temperature on the other side (T_∞) = 90°C
- Convective heat transfer coefficient (\bar{h}_c) = $500 \text{ W/(m}^2 \text{ K)}$
- Thermal conductivity (k) = 12 W/(m K)

FIND

- The maximum temperature in the wall (T_{\max})

ASSUMPTIONS

- The heat loss through the insulation is negligible
- The system has reached steady state
- One dimensional conduction through the wall

SKETCH

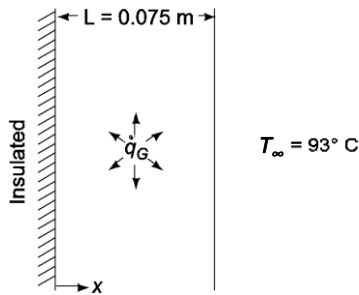

SOLUTION

The one dimensional conduction equation, given in Equation (2.5), is

$$k \frac{\partial^2 T}{\partial x^2} + \dot{q}_G = \rho c \frac{\partial T}{\partial t}$$

For steady state, $\frac{\partial T}{\partial t} = 0$ therefore

$$k \frac{d^2 T}{dx^2} + \dot{q}_G = 0$$

$$\frac{d^2T}{dx^2} = -\frac{\dot{q}_G}{k}$$

This is subject to the following boundary conditions

No heat loss through the insulation

$$\frac{dT}{dx} = 0 \text{ at } x = 0$$

Convection at the other surface

$$-k \frac{dT}{dx} = \bar{h}_c (T - T_\infty) \quad \text{at } x = L$$

Integrating the conduction equation once

$$\frac{dT}{dx} = \frac{\dot{q}_G}{k} + C_1$$

C_1 can be evaluated using the first boundary condition

$$0 = -\frac{\dot{q}_G}{k}(0) + C_1 \Rightarrow C_1 = 0$$

Integrating again

$$T = -\frac{\dot{q}_G}{2k} x^2 + C_2$$

The expression for T and its first derivative can be substituted into the second boundary condition to evaluate the constant C_2

$$-k \left(\frac{\dot{q}_G L}{k} \right) = \bar{h}_c \left(-\frac{\dot{q}_G L^2}{2k} + C_2 - T_\infty \right) \Rightarrow C_2 = \dot{q}_G L \left(\frac{1}{\bar{h}_c} + \frac{1}{2k} \right) + T_\infty$$

Substituting this into the expression for T yields the temperature distribution in the wall

$$T(x) = \frac{\dot{q}_G}{2k} x^2 + \dot{q}_G L \left(\frac{1}{\bar{h}_c} + \frac{1}{2k} \right) + T_\infty$$

$$T(x) = T_\infty + \frac{\dot{q}_G}{2k} \left(L^2 + \frac{2kL}{\bar{h}_c} - x^2 \right)$$

Examination of this expression reveals that the maximum temperature occurs at $x = 0$

$$T_{\max} = T_\infty + \frac{\dot{q}_G}{2k} \left(L^2 + \frac{2kL}{\bar{h}_c} \right)$$

$$T_{\max} = 90^\circ\text{C} + \frac{10^5 \text{ W/m}^3}{2[12\text{W/(mK)}]} \left((0.075 \text{ m})^2 + \frac{2[12 \text{ W/(mK)}](0.075 \text{ m})}{500 \text{ W/(m}^2\text{K)}} \right) = 128^\circ\text{C}$$

PROBLEM 2.2

A small dam, which may be idealized by a large slab 1.2 m thick, is to be completely poured in a short period of time. The hydration of the concrete results in the equivalent of a distributed source of constant strength of 100 W/m^3 . If both dam surfaces are at 16°C , determine the maximum temperature to which the concrete will be subjected, assuming steady-state conditions. The thermal conductivity of the wet concrete may be taken as 0.84 W/(m K) .

GIVEN

Large slab with internal heat generation
Internal heat generation rate (\dot{q}_G) = 100 W/m^3
Both surface temperatures (T_s) = 16°C
Thermal conductivity (k) = 0.84 W/(m K)

FIND

The maximum temperature (T_{\max})

ASSUMPTIONS

Steady state conditions prevail

SKETCH

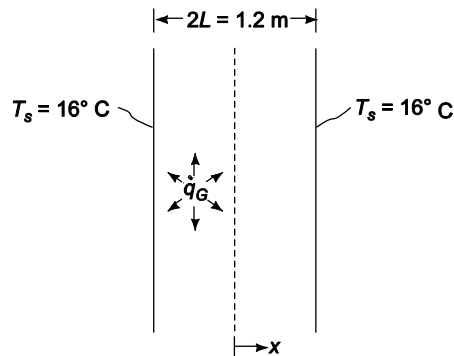

SOLUTION

The dam is symmetric. Therefore, x will be measured from the centerline of the dam. The equation for one dimensional conduction is given by Equation (2.5)

$$k \frac{\partial^2 T}{\partial x^2} + \dot{q}_G = \rho c \frac{\partial T}{\partial t}$$

For steady state, $\frac{\partial T}{\partial t} = 0$ therefore

$$k \frac{d^2 T}{dx^2} + \dot{q}_G = 0$$

This is subject to the following boundary conditions

1. By symmetry, $dT/dx = 0$ at $x = 0$
2. $T = T_s$ at $x = L$

Also note that for this problem \dot{q}_G is a constant.

Integrating the conduction equation

$$\frac{dT}{dx} = -\frac{\dot{q}_G}{k}x + C_1$$

The constant C_1 can be evaluated using the first boundary condition

$$0 = -\frac{\dot{q}_G}{k}(0) + C_1 \Rightarrow C_1 = 0$$

Integrating once again

$$T = \frac{\dot{q}_G}{2k}x^2 + C_2$$

The constant C_2 can be evaluated using the second boundary condition

$$T_s = \frac{\dot{q}_G}{2k}L^2 + C_2 \Rightarrow C_2 = T_s + \frac{\dot{q}_G}{2k}L^2$$

Therefore, the temperature distribution in the dam is

$$T = T_s + \frac{\dot{q}_G}{2k}(L^2 - x^2)$$

The maximum temperature occurs at $x = 0$

$$T_{\max} = T_s + \frac{\dot{q}_G}{2k}(L^2 - (0)^2) = 16^\circ\text{C} + \frac{100\text{ W/m}^3}{2[0.84\text{ W/(m K)}]}(0.6\text{ m})^2 = 37^\circ\text{C}$$

COMMENTS

This problem is simplified significantly by choosing $x = 0$ at the centerline and taking advantage of the problem's symmetry.

For a more complete analysis, the change in thermal conductivity with temperature and moisture content should be measured. The system could then be analyzed by numerical methods discussed in chapter 4.

PROBLEM 2.3

The shield of a nuclear reactor is idealized by a large 25 cm thick flat plate having a thermal conductivity of 3.5 W/(m K). Radiation from the interior of the reactor penetrates the shield and there produces heat generation that decreases exponentially from a value of 187.6 kW/m³ at the inner surface to a value of 18.76 kW/m³ at a distance of 12.5 cm from the interior surface. If the exterior surface is kept at 38°C by forced convection, determine the temperature at the inner surface of the shield. Hint: First set up the differential equation for a system in which the heat generation rate varies according to $\dot{q}(x) = \dot{q}(0)e^{-cx}$.

GIVEN

Large flat plate with non-uniform internal heat generation

Thickness (L) = 25 cm = 0.25 m

Thermal conductivity (k) = 3.5 W/(m K)

Exterior surface temperature (T_o) = 38°C

Heat generation is exponential with values of

- 187.6 kW/m³ at the inner surface
- 18.76 kW/m³ at 12.5 cm from the inner surface

FIND

The inner surface temperature (T_i)

ASSUMPTIONS

One dimensional, steady state conduction

The thermal conductivity is constant

No heat transfer at the inner surface of the shield

SKETCH

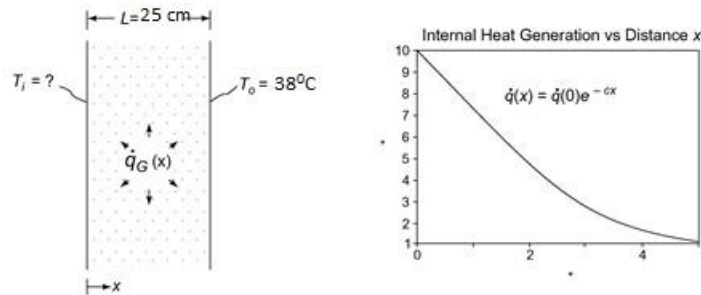

SOLUTION

From the hint, the internal heat generation is

$$\dot{q}(x) = \dot{q}(0) e^{-cx} \text{ where } \dot{q}(0) = 187.6 \text{ kW/m}^3$$

Solving for the constant c using the fact that $q(x) = 18.76 \text{ kW/m}^3$ at $x = 12.5 \text{ cm} = 0.125 \text{ m}$

$$c = -\frac{1}{x} \ln \left(\frac{\dot{q}(x)}{\dot{q}(0)} \right) = -\frac{1}{0.125 \text{ m}} \ln \left(\frac{18.76 \text{ kW/m}^3}{187.6 \text{ kW/m}^3} \right) = 18.42 \frac{1}{\text{m}}$$

The one dimensional conduction equation is given by Equation (2.5)

$$k \frac{\partial^2 T}{\partial x^2} + \dot{q}_G = \rho c \frac{\partial T}{\partial t} = 0 \text{ (steady state)}$$

$$\frac{d^2 T}{dx^2} = -\frac{\dot{q}_G(x)}{k} = \frac{\dot{q}(0)}{k} e^{-cx}$$

The boundary conditions are

$$\frac{dT}{dx} = 0 \text{ at } x = 0$$

$$T(L) = T_o = 100^\circ\text{F at } x = L$$

Integrating the conduction equation

$$\frac{dT}{dx} = -\frac{\dot{q}(0)}{ck} e^{-cx} + C_1$$

The constant C_1 can be evaluated by applying the first boundary condition

$$0 = -\frac{\dot{q}(0)}{ck} e^{-c(0)} + C_1 \Rightarrow C_1 = \underline{\underline{-\frac{\dot{q}(0)}{ck}}}$$

Integrating again

$$T(x) = \frac{-\dot{q}(0)}{c^2 k} e^{-cx} - \frac{\dot{q}(0)}{c^2 k} x + C_2$$

The constant C_2 can be evaluated by applying the second boundary condition

$$T(L) = T_o = \frac{-\dot{q}(0)}{c^2 k} e^{-cL} - \frac{\dot{q}(0)}{c^2 k} L + C_2 \Rightarrow C_2 = T_o + \frac{\dot{q}(0)}{ck} \left(L + \frac{1}{c} e^{-cL} \right)$$

Therefore, the temperature distribution is

$$T(x) = T_o + \frac{-\dot{q}(0)}{c^2 k} [e^{-cL} - e^{-cx} + c(L-x)]$$

Solving for the temperature at the inside surface ($x = 0$)

$$T_i = T(0) = T_o + \frac{\dot{q}(0)}{c^2 k} [e^{-cL} - 1 + cL]$$

$$T_i = 38^\circ\text{C} + \frac{187600 \text{ W/m}^3}{\left(\frac{18.42}{m}\right)^2 (3.5 \text{ W/(m K)})} \left[e^{-(18.42/m) 0.25m} - 1 + 18.42 \frac{1}{m} (0.25m) \right]$$

$$= 38^\circ\text{C} + \frac{187600 \text{ W/m}^3}{2} * 3.615 = 609^\circ\text{C}$$

$$\left(\frac{18.42}{m}\right) (3.5 \text{ W/(m K)})$$

PROBLEM 2.4

A plane wall 15 cm thick has a thermal conductivity given by the relation

$$k = 2.0 + 0.0005 T \text{ W/(m K)}$$

where T is in degrees Kelvin. If one surface of this wall is maintained at 150°C and the other at 50°C , determine the rate of heat transfer per square meter. Sketch the temperature distribution through the wall.

GIVEN

A plane wall

Thickness (L) = 15 cm = 0.15 m

Thermal conductivity (k) = $2.0 + 0.0005 T$ W/(m K) (with T in Kelvin)

Surface temperatures: $T_h = 150^\circ\text{C}$ $T_c = 50^\circ\text{C}$

FIND

(a) The rate of heat transfer per square meter (q/A)

(b) The temperature distribution through the wall

ASSUMPTIONS

The wall has reached steady state

Conduction occurs in one dimension

SKETCH

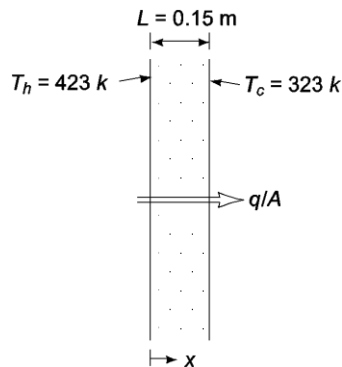

SOLUTION

Simplifying Equation (2.2) for steady state conduction with no internal heat generation but allowing for the variation of thermal conductivity with temperature yields

$$\frac{d}{dx} k \frac{dT}{dx} = 0$$

with boundary conditions: $T = 423 \text{ K}$ at $x = 0$

$$T = 323 \text{ K} \text{ at } x = 0.15 \text{ m}$$

The rate of heat transfer does not vary with x

$$-k \frac{dT}{dx} = \frac{q}{A} = \text{constant}$$

$$-(2.0 + 0.0005T) dT = \frac{q}{A} dx$$

Integrating

$$2.0T + 0.00025 T^2 = -\frac{q}{A} x + C$$

The constant can be evaluated using the first boundary condition

$$2.0 (423) + 0.00025 (423)^2 = C - \frac{q}{A} (0) \Rightarrow C = 890.7$$

(a) The rate of heat transfer can be evaluated using the second boundary condition:

$$2.0 (323) + 0.00025 (323)^2 = 890.7 - \frac{q}{A} (0.15 \text{ m}) \Rightarrow q_k = 1457 \text{ W/m}^2$$

(b) Therefore, the temperature distribution is

$$0.00025 T^2 + 2.0 T = 890.7 - 1458 x$$

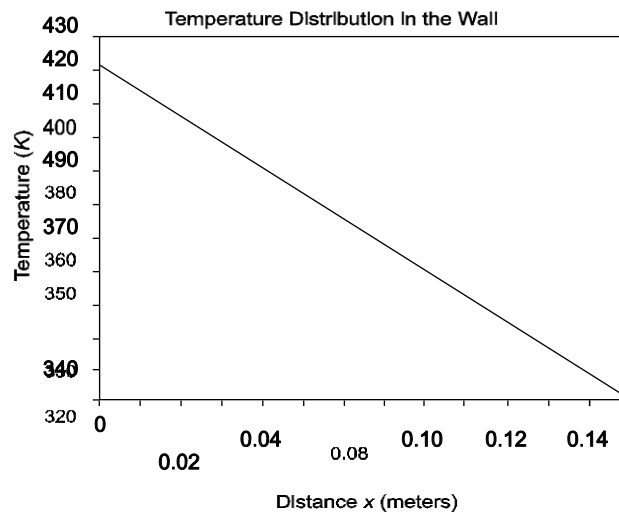

COMMENTS

Notice that although the temperature distribution is not linear due to the variation of the thermal conductivity with temperature, it is nearly linear because this variation is small compared to the value of the thermal conductivity.

If the variation of thermal conductivity with temperature had been neglected, the rate of heat transfer would have been 1333 W/m^2 , an error of 8.5%.

PROBLEM 2.5

Derive an expression for the temperature distribution in a plane wall in which there are uniformly distributed heat sources that vary according to the linear relation

$$\dot{q}_G = \dot{q}_w [1 - \beta(T - T_w)]$$

where \dot{q}_w is a constant equal to the heat generation per unit volume at the wall temperature T_w . Both sides of the plate are maintained at T_w and the plate thickness is $2L$.

GIVEN

A plane wall with uniformly distributed heat sources as in the above equation
Both surface temperatures = T_w
Thickness = $2L$

FIND

An expression for the temperature distribution

ASSUMPTIONS

Constant thermal conductivity (k)

SKETCH

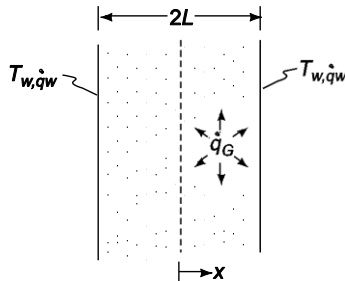

SOLUTION

The equation for one dimensional, steady state ($dT/dt = 0$) conduction from Equation (2.5) is

$$\frac{d^2T}{dx^2} = \frac{-\dot{q}_G}{k} = \frac{-\dot{q}_w}{k} [1 - \beta(T - T_w)] = \frac{\dot{q}_w\beta}{k} (T - T_w) - \frac{\dot{q}_w}{k}$$

With the boundary conditions

$$\frac{dT}{dx} = 0 \text{ at } x = 0$$

$$T = T_w \text{ at } x = L$$

Let $\theta = T - T_w$ and $m^2 = (\dot{q}_w\beta)/k$ then

$$\frac{d^2\theta}{dx^2} - m^2\theta = -\frac{\dot{q}_w}{k}$$

This is a second order, linear, nonhomogeneous differential equation with constant coefficients. Its solution is the addition of the homogeneous solution and a particular solution. The solution to the homogeneous equation

$$\frac{d^2\theta}{dx^2} - m^2\theta = 0$$

is determined by its characteristics equation. Substituting $\theta = e^{\lambda x}$ and its derivatives into the homogeneous equation yields the characteristics equation

$$\lambda^2 e^{\lambda x} - m^2 e^{\lambda x} = 0 \Rightarrow \lambda = m$$

Therefore, the homogeneous solution has the form

$$\theta_h = C_1 e^{mx} + C_2 e^{-mx}$$

A particular solution for this problem is simply a constant: $\theta = a_o$

Substituting this into the differential equation

$$0 - m^2 a_o = \frac{\dot{q}_w}{-k} \Rightarrow a_o = \frac{\dot{q}_w}{m^2 k}$$

Therefore, the general solution is

$$\theta = C_1 e^{mx} + C_2 e^{-mx} + \frac{\dot{q}_w}{m^2 k}$$

With the boundary condition

$$\frac{d\theta}{dx} = 0 \text{ at } x = 0$$

$$\theta = 0 \text{ at } x = L$$

Applying the first boundary condition:

$$\frac{d\theta}{dx} = C_1 m e^{(0)} - C_2 m e^{(0)} = 0 \Rightarrow C_1 = C_2 = C$$

From the second boundary condition

$$0 = C (e^{mL} + e^{-mL}) + \frac{\dot{q}_w}{m^2 k} \Rightarrow C = \frac{-\dot{q}_w}{m^2 k (e^{mL} + e^{-mL})}$$

The temperature distribution in the wall is

$$\theta = T(x) - T_w = \frac{-\dot{q}_w}{m^2 k (e^{mL} + e^{-mL})} (e^{mx} + e^{-mx}) + \frac{\dot{q}_w}{m^2 k}$$

$$T(x) = T_w + \frac{\dot{q}_w}{m^2 k} \left(1 - \frac{e^{mx} + e^{-mx}}{e^{mL} + e^{-mL}} \right)$$

$$T(x) = T_w + \frac{\dot{q}_w}{m^2 k} \left(1 - \frac{\cosh(mx)}{\cosh(mL)} \right)$$

PROBLEM 2.6

A plane wall of thickness $2L$ has internal heat sources whose strength varies according to

$$\dot{q}_G = \dot{q}_0 \cos(ax)$$

where \dot{q}_0 is the heat generated per unit volume at the center of the wall ($x = 0$) and a is a constant. If both sides of the wall are maintained at a constant temperature of T_w , derive an expression for the total heat loss from the wall per unit surface area.

GIVEN

A plane wall with internal heat sources

Heat source strength: $\dot{q}_G = \dot{q}_0 \cos(ax)$

Wall surface temperatures = T_w

Wall thickness = $2L$

FIND

An expression for the total heat loss per unit area (q/A)

ASSUMPTIONS

Steady state conditions prevail

The thermal conductivity of the wall (k) is constant

One dimensional conduction within the wall

SKETCH

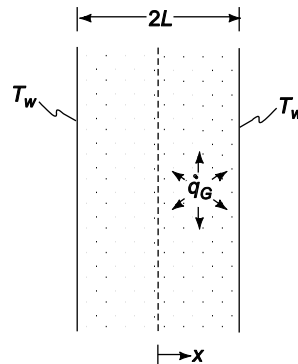

SOLUTION

Equation (2.5) gives the equation for one dimensional conduction. For steady state, $dT/dt = 0$, therefore

$$k \frac{\partial^2 T}{\partial x^2} + \dot{q}_G = \rho c \frac{\partial T}{\partial t} = 0$$

$$\frac{d^2 T}{dx^2} = \frac{-\dot{q}_G}{k} = \frac{-\dot{q}_0 \cos(ax)}{k}$$

With boundary conditions:

$$\frac{dT}{dx} = 0 \text{ at } x = 0 \text{ (by symmetry)}$$

$$T = T_w \text{ at } x = L \text{ (given)}$$

Integrating the conduction equation once

$$\frac{dT}{dx} = -\frac{\dot{q}_o}{ak} \sin(ax) + C_1$$

Applying the first boundary condition yields: $C_1 = 0$

The rate of heat transfer from one side of the wall is

$$q_k = -kA \left. \frac{dT}{dx} \right|_{x=L} = -kA \left[-\frac{\dot{q}_o}{ak} \sin(aL) \right] = \frac{\dot{q}_o A}{a} \sin$$

The total rate of heat transfer is twice the rate of heat transfer from one side of the wall

$$\left(\frac{q_k}{A} \right)_{\text{total}} = \frac{2\dot{q}_o}{a} \sin(aL)$$

An alternative method of solution for this problem involves recognizing that at steady state the rate of heat generation within the entire wall must equal the rate of heat transfer from the wall surfaces

$$A \int_{-L}^L \dot{q}_G(x) dx = q$$

$$\dot{q}_o \int_{-L}^L \cos(ax) dx = \frac{q}{A}$$
$$\frac{\dot{q}_o}{a} \sin(aL) - \sin(-aL) = \frac{q}{A}$$

$$\frac{q}{A} = \frac{2\dot{q}_o}{a} \sin(aL)$$

COMMENTS

The heat loss can be determined by solving for the temperature distribution and then the rate of heat transfer or via the conservation of energy which allows us to equate the heat generation rate with the rate of heat loss.

PROBLEM 2.7

A very thin silicon chip is bonded to a 6-mm thick aluminum substrate by a 0.02-mm thick epoxy glue. Both surfaces of this chip-aluminum system are cooled by air at 25°C, where the convective heat transfer coefficient of air flow is 100 W/(m² K). If the heat dissipation per unit area from the chip is 10⁴ W/m² under steady state condition, draw the thermal circuit for the system and determine the operating temperature of the chip.

GIVEN

Silicon chip bonded to 6-mm thick aluminum substrate by 0.02-mm thick epoxy glue
 Air temperature (T_∞) = 25°C
 Convective heat transfer coefficient (h) = 100 W/(m² K)
 Heat dissipation from chip (q/A) = 10⁴ W/m²

FIND

Draw thermal circuit of system
 Operating temperature of the chip.

ASSUMPTIONS

1-Dimensional Steady state conditions prevail
 Negligible heat loss from the sides
 Isothermal chip
 Negligible radiation

SKETCH

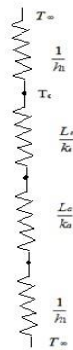

SOLUTION

From the figure

Total heat transferred to the surrounding is sum of heat transferred from upper surface and lower surface.
 Thus

$$q = q_1 + q_2$$

$$q = \frac{T_c - T_\infty}{\frac{1}{h_1}} + \frac{T_c - T_\infty}{\frac{L_e}{k_e} + \frac{L_e}{k_a} + \frac{1}{h_2}}$$

$\frac{m \quad K \quad W}{h_1 \quad h_1 \quad k_e \quad k_a}$

$$q = \frac{T_c - 298K}{\frac{1}{1000} + \frac{T_c - T_\infty}{10^{-4} + \frac{6 * 10^{-3}}{1644} + \frac{10^{-5}}{50}} (m^2 K / W)} = 10^4 \text{ W/m}^2$$

$$10^4 = \frac{201.36 * 10^{-4} (T_c - 298) + 10^{-4} * 10 (T_c - 298)}{2513.6 * 10^{-4} * 10^{-4}}$$

$$2513.6 + 62985.28 = 211.36 * T_c$$

$$T_c = 310 \text{ K}$$

COMMENT

The heat transfer occurs on both sides through the chip to the surrounding. As there are both conductive and convective resistances on the lower side heat flow rate on the lower side will be less than that on the upper side which has only convective resistance.

PROBLEM 2.8

A thin, flat plate integrated circuit of 5 mm thickness is cooled on its upper surface by a dielectric liquid. The heat dissipation rate from the chip is 20,000 W/m² and with the coolant flow at a free stream temperature of T_{∞,l}=25°C, the convective heat transfer coefficient between the chip surface and the liquid is 1000 W/(m² K). On the lower surface, the chip is attached to a circuit board, where the thermal contact resistance between the chip and the board is 10⁻⁴ m².K/W. The thermal conductivity of board material is 1.0 W/m. K, and its other surface (away from the chip) is exposed to ambient air at T_{∞,a}=20°C where it is cooled by natural convection with the heat transfer coefficient of 30 W/(m² K). (a) Determine the chip surface temperature under steady state condition for the described conditions. (b) If the maximum chip temperature is not to exceed 75°C, determine maximum allowable heat flux that is generated by the chip. (c) A colleague suggests that in order to improve the cooling, you use a high conductivity bonding base at chip-board interface that would reduce the thermal contact resistance at the interface to 10⁻⁵ m².K/W. Determine the consequent increase in the chip heat flux that can be sustained.

GIVEN

- Heat dissipation rate (\dot{q})= 20,000 W/m²
- Coolant free stream temp (T_{∞,l})= 25°C
- Ambient air temperature (T_{∞,a})= 20°C
- Heat transfer coefficient (h)= 1000 W/(m² K)
- Thermal contact resistance (R_{tc})=10⁻⁴ m².K/W
- Maximum chip temperature=75°C

FIND

- (a) Chip surface temperature under steady state condition
- (b) Maximum allowable heat flux generated by the chip
- (c) Consequent increase in chip heat flux if high conductivity bonding is used.

ASSUMPTIONS

- Steady state conditions prevail
- The thermal conductivity of the wall (k) is constant
- One dimensional conduction
- Negligible radiation and thermal resistance between chip surface and the liquid.

SKETCH

The thermal circuit of problem is given by

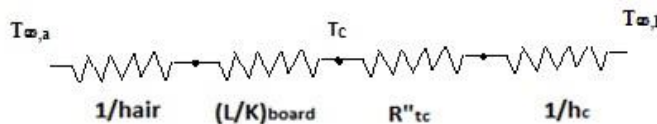

SOLUTION

(a) A heat balance in the above problem gives

$$\dot{q} = \dot{q}_{liquid} + \dot{q}_{air}$$

Substituting values from thermal circuits

$$20000 \text{ W/m}^2 = \frac{T_c - 298 \text{ K}}{\frac{1}{1000}} + \frac{T_c - T_\infty}{\frac{1}{30} + \frac{0.005}{1} + 0.0001} \frac{K}{(m^2 K / W)}$$

$$20000 \text{ W/m}^2 = (T_c - 298) * 1000 + (T_c - 293) / 0.03843 \text{ W/m}^2$$

$$20000 \text{ W/m}^2 = (1000T_c - 298000 + 26.01T_c - 7620.93) \text{ W/m}^2$$

Solving for T_c , we get $T_c = 317.63 \text{ K}$ or $44.37 \text{ }^\circ\text{C}$

(b) $T_{c,\text{max}} = 75^\circ\text{C} = 343 \text{ K}$

Solving for q from above equation, we get

$$Q = 50 * 1000 + 55 * 26.01 \text{ W/m}^2$$

$$= 50000 + 1430.55 \text{ W/m}^2$$

$$= 5.14 * 10^4 \text{ W/m}^2$$

- (c) Using the same equation as in (a), and changing only the value of thermal resistance, and using the value of T_c as 343 K , we get $q = 4.63 * 10^4 \text{ W/m}^2$, which is a decrease in allowable heat dissipation of around 5126 W/m^2 .

PROBLEM 2.9

In a large chemical factory, hot gases at 2273 K are cooled by a liquid at 373 K with gas side and liquid side convection heat transfer coefficients of 50 and 1000 W/(m² K), respectively. The wall that separates the gas and liquid streams is composed of 2-cm thick slab of stainless steel on the liquid side. There is a contact resistance between the oxide layer and the steel of 0.05 m².K/W. Determine the rate of heat loss from hot gases through the composite wall to the liquid.

GIVEN

- Hot gases at $T_g=2273$ K cooled by liquid at $T_f=373$ K
- Convection heat transfer coefficients on gas side $h_g=50$ W/(m² K) and $h_f=100$ W/(m² K)
- Wall of stainless steel of thickness(L)= 2 cm = 0.02 m
- Contact resistance (R_{cr})= 0.05 m².K/W

FIND

Rate of heat loss from hot gases through composite wall to liquid.

ASSUMPTIONS

- 1 Dimensional steady state heat transfer
- Thermal conductivity remain constant.
- Radiation is negligible.

SKETCH

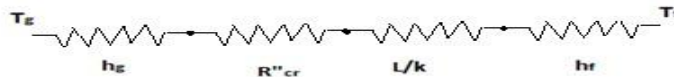

PROPERTIES AND CONSTANTS

From Appendix 2, Table 10, Thermal conductivity of stainless steel (k) = 14.4 W/(m² K)

SOLUTION

Total resistance for the heat flow through the pipe is given by

$$\begin{aligned} R_{total} &= \frac{1}{h_f} + R''_{cr} + \frac{L}{k} + \frac{1}{h_g} \text{ m}^2.\text{K/W} \\ &= \frac{1}{50} + 0.05 + \frac{0.02}{14.4} + \frac{1}{100} \text{ m}^2.\text{K/W} \\ &= 0.02 + 0.05 + 0.0014 + 0.01 \text{ m}^2.\text{K/W} \\ &= 0.0814 \text{ m}^2.\text{K/W} \end{aligned}$$

Heat flux for the above resistance for given temperature difference is given by

$$\begin{aligned} \dot{q} &= (T_g - T_f) / R_{total} \text{ W/m}^2 \\ &= (2273 - 373) / 0.0814 \text{ W/m}^2 = 23342 \text{ W/m}^2 \end{aligned}$$

PROBLEM 2.10

The conversion of solar energy into electric power by means of photovoltaic panels will be an important part of the transition from fossil fuels to sustainable energy resources. As described in detail in Principles of Sustainable Energy, a typical PV panel consists of a top layer of glass attached with a thin optically clear adhesive to a very thin layer of photoelectric material such as doped-silicon in which the incident solar irradiation is converted into electric energy. Experiments have shown that the solar to electric efficiency $\eta=0.55-0.001T_{\text{silicon}}$, where T_{silicon} is the silicon temperature in K. In a typical installation where solar irradiation is $G=700 \text{ W/m}^2$, 7% is reflected from the top surface of the glass, 10% is absorbed by the glass, and 83% is transmitted to the photovoltaic active layer. A part of irradiation absorbed by photovoltaic material is converted into heat and the remainder is converted into electric energy. The silicon layer is attached by a 0.01-mm thick layer of solder to a 3-mm thick aluminum nitride substrate as shown in the schematic. Determine the electric power produced by this PV panel, assuming the following properties for the pertinent materials: conductivity of the glass $k_g=1.4 \text{ W/(m K)}$, conductivity of the adhesive $k_a=145 \text{ W/(m K)}$, the emissivity of the glass is 0.90, heat transfer coefficient from the top of the panel to the surrounding is $35 \text{ W/(m}^2 \text{ K)}$, and the surrounding air temperature is $T_{\text{air}}=20^\circ\text{C}$. The solar PV panel is 5 m long and 1 m wide and is situated on the roof where the bottom is considered insulated. (Hint: Start by applying first law of thermodynamics to the photovoltaic-active layer and note that some of the irradiation will be converted to electricity and some of it transmitted thermally).

GIVEN

- Electric efficiency $\eta=0.55-0.001T_{\text{silicon}}$
- Solar irradiation is $G=700 \text{ W/m}^2$
- Thickness of solder ($t_s=0.01 \text{ mm}$)
- Al substrate thickness ($t_{\text{Al}}=3 \text{ mm}=0.003 \text{ m}$)
- Conductivity of the glass $k_g=1.4 \text{ W/(m K)}$
- Conductivity of the adhesive $k_a=145 \text{ W/(m K)}$
- Emissivity of the glass is 0.90
- Heat transfer coefficient from the top of the panel to the surrounding ($h_c=35 \text{ W/(m}^2 \text{ K)}$),
- Surrounding air temperature is $T_{\text{air}}=20^\circ\text{C}$.
- Solar PV panel area= $5 \text{ m} \times 1 \text{ m}$

FIND

Electric power produced by the PV panel.

ASSUMPTIONS

- 1 Dimensional steady state heat transfer
- Thermal conductivity remains constant.

SKETCH

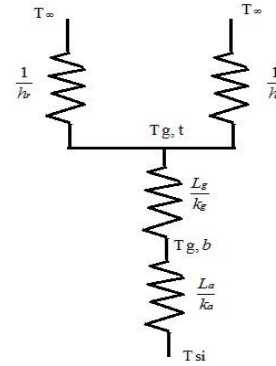
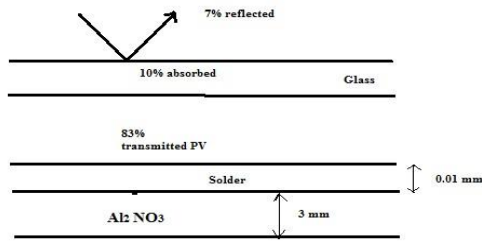

PROPERTIES AND CONSTANTS

From Appendix 2, Table 10, Thermal conductivity of stainless steel (k) = 14.4 W/(m² K)

SOLUTION

The energy which is not converted to electrical energy is transferred to the ambience through the adhesive and glass layer.

$$Q_{\text{loss}} = 0.83G_s(1-\eta) = \frac{T_{si} - T_{g,t}}{\frac{L}{k_a} + \frac{L_g}{k_g}} \Rightarrow 0.83 \cdot 700 \cdot (1 - 0.55 + 0.001T_{si}) = \frac{10^{-5} + 3 \cdot 10^{-3}}{145 + 1.5} T_{si} - T_{g,t}$$

$$T_{si} - T_{g,t} = 0.523 + 0.00162 T_{si} \Rightarrow T_{si} = 0.524 + 1.0016 T_{g,t}$$

Also under steady state the heat transferred to the glass should be equal to total heat loss through glass to ambience.

$$0.83G_s(1-\eta) + 0.1G_s = \frac{T_{g,t} - T_{\infty}}{h_c} + 0.9\sigma(T_{g,t}^4 - T_{\infty}^4)$$

$$0.83 \cdot 700 \cdot (1 - 0.55 + 0.001T_{si}) + 0.1 \cdot 700 = 35(T_{g,t} - 293) + 0.9 \cdot 5.67 \cdot 10^{-8} \cdot (T_{g,t}^4 - 293^4)$$

$$5.103 \cdot 10^{-8} T_{g,t}^4 + 35T_{g,t} = 331.45 + 10255 + 376 + 0.581T_{si}$$

$$5.103 \cdot 10^{-8} T_{g,t}^4 + 35T_{g,t} = 10962.45 + 0.581T_{si}$$

Solving the above two equation in mathematical computational software (eg. Mathematica) we get

$$T_{si} = 306.6 \text{ K} \ \& \ T_{g,t} = 305.6 \text{ K}$$

$$\text{Total power} = 0.83G_s(1-\eta) \cdot A$$

$$= 0.83 \cdot 700 \cdot (1 - 0.55 + 0.001 \cdot 306.6) \cdot 1 \cdot 5 = 2198 \text{ W} = 2.198 \text{ KW.}$$

COMMENTS

The capacity of PV panel also depends on its cross sectional area. Thus more power can be generated if larger cross section of photovoltaic panels are used.

PROBLEM 2.11

For the design of novel type of nuclear power plant, it is necessary to determine the temperature distribution in a large slab-type nuclear fuel element. Volumetric heat is generated uniformly in the fuel element at the rate of $2 \times 10^7 \text{ W/m}^3$. This slab fuel is insulated on one side, while on other side it is covered by a stainless steel cladding of 0.3 cm thickness. Heat is removed from the fuel slab by a liquid at 200°C that flows on the other side of the steel cladding with the convective heat transfer coefficient of $10,000 \text{ W/(m}^2 \text{ K)}$. Determine the maximum temperature in the fuel element and sketch the temperature distribution.

GIVEN

- Volumetric heat generated (\dot{q}) = $2 \times 10^7 \text{ W/m}^3$
- Stainless steel cladding thickness (y) = $0.3 \text{ cm} = 0.003 \text{ m}$
- Coolant liquid temperature (T_∞) = 200°C
- Heat transfer coefficient (h) = $1000 \text{ W/(m}^2 \text{ K)}$
- Fuel element thickness (x) = $1.5 \text{ cm} = 0.015 \text{ m}$

FIND

Maximum temperature in fuel element
Sketch temperature distribution.

ASSUMPTIONS

- 1 Dimensional steady state heat transfer
- Constant properties.
- Uniform heat generation.
- Negligible contact resistance between surfaces.

SKETCH

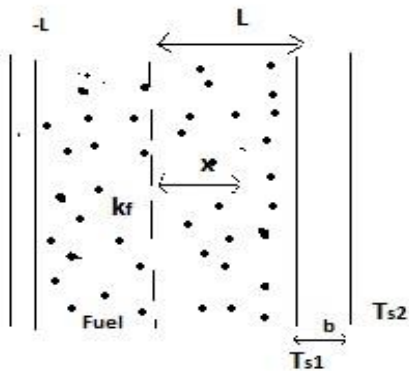

PROPERTIES AND CONSTANTS

From Appendix 2, Table 10, Thermal conductivity of stainless steel (k) = 14.4 W/(m2 K)

SOLUTION

Heat transfer equation in 1 dimension with steady state and uniform heat generation is given by

$$\frac{\partial^2 T}{\partial x^2} + \frac{\dot{q}}{k_f} = 0 \text{ where } x \text{ varies from } -L \text{ to } L$$

Integrating twice we get

$$\frac{dT}{dx} = -\frac{\dot{q}}{k_f}x + C_1 \text{ and}$$

$$T = -\frac{\dot{q}}{2k_f}x^2 + C_1x + C_2 \text{ where } C_1 \text{ and } C_2 \text{ are constants.}$$

Applying boundary conditions

1. The wall is insulated at the end thus $\dot{q}(x=L)=0$ (which implies $\frac{dT}{dx}=0$)

Substituting this in first order equation above we get

$$\frac{dT}{dx}(x=L) = -\frac{\dot{q}}{k_f}(L) + C_1$$

$$C_1 = \left(\frac{\dot{q}}{k_f}L \right)$$

2. Using energy conservation equation

$$\dot{q}_{\text{conduction}} = \dot{q}_{\text{convection}}$$

$$\dot{q}_{\text{conduction}} \text{ equation considering unit width } \dot{q}(2L) = \frac{k_s}{b}(T_{s1} - T_{s2})$$

$$\dot{q}_{\text{convection}} \text{ equation is } \frac{k_s}{b}(T_{s1} - T_{s2}) = h(T_{s2} - T_{\infty})$$

Equating these two above equations at L we get

$$T(L) = T_{s1} = \frac{q(2Lb)}{k_s} + \frac{q(2L)}{h} + T_{\infty}$$

The differential equation at x=L gives

$$T_{x=L} = -\frac{\dot{q}}{2k_f}L^2 - \frac{\dot{q}}{k_f}L^2 + C_2$$

Equating both and solving for C₂ we get

$$C_2 = T_{\infty} + \dot{q}L \left(\frac{2b}{k_s} + \frac{2}{h} + \frac{3L}{k_f} \right)$$

Substituting C₁ and C₂ in the integrated differential equation we get

$$T = -\frac{\dot{q}}{2k_f}x^2 - \frac{\dot{q}}{k_f}Lx + T_{\infty} + \dot{q}L \left(\frac{2b}{k_s} + \frac{2}{h} + \frac{3L}{k_f} \right)$$

$$T_{\text{max}} \text{ occurs at } \frac{dT}{dx} = 0$$

Applying this condition in differential equation above we get

$$-\frac{\dot{q}}{k_f} x - \frac{\dot{q}}{k_f} L = 0 \text{ which implies } T_{\max} \text{ is at } -L. \text{ Thus}$$

$$T_{\max} = \frac{\dot{q}}{2k_f} L^2 + T_{\infty} + \dot{q}L \left(\frac{2b}{k_s} + \frac{2}{h} + \frac{3L}{2k_f} \right)$$

Substituting values to get T_{\max} we get

$$T_{\max} = \frac{2 * 10^7}{2 * 60} (7.5 * 10^{-3})^2 + T_{\infty} + 2 * 10^7 * 7.5 * 10^{-3} \left(\frac{2 * 3 * 10^{-3}}{14.4} + \frac{2}{10000} + \frac{3 * 7.5 * 10^{-3}}{2 * 60} \right)$$

$$T_{\max} = 9.375 + 200 + 55.63 \text{ K}$$

$$= 265 \text{ K}$$

PROBLEM 2.12

Nomads in the desert make ice by exposing a thin water layer to cold air during the night. The icing or freezing of thin layers of water is often also referred to as ice making by nocturnal (or night time) cooling, where the surface temperature of water is lowered considerably by radioactive and convective cooling, and it had been practiced extensively in ancient India. To model this process and evaluate the conduction process in water layer, consider a 5-mm thick horizontal layer gets cooled such that its top surface is at temperature of -5°C. After a while the water begins to freeze at top surface and the ice front expands downwards through the water layer. Determine the location of solid liquid(ice-water) interface if the bottom surface temperature of the liquid water is at 3°C. State your assumptions for the model and calculations.

GIVEN

- Thickness of the layer(t)= 5 mm
- Surface temperature (Ts)= -5°C=268 K
- Water temperature(Tw)= 3°C= 276 K

FIND

Location of solid liquid interface .

ASSUMPTIONS

- 1 Dimensional steady state heat transfer
- Constant properties throughout time
- Negligible radiation
- Negligible convection by liquid.

SKETCH



PROPERTIES AND CONSTANTS

From Appendix 2, Table 10,

For water at 273 K, kw=0.569 W/mK

For ice at 273 K, ki=1.88 W/mK

SOLUTION

If x is the distance of solid liquid interface from liquid surface, the energy balance over the interface gives

$$\frac{k_w * (T_w - 273)}{x} = \frac{k_i * (273 - T_s)}{5 - x} \Rightarrow \frac{0.569 * (276 - 273)}{x} = \frac{1.88 * (273 - 268)}{5 - x}$$

Solving for x we get

$$1.707(5-x) = 9.4 x \Rightarrow x=0.77 \text{ mm}$$

Thus the interface is at distance of 0.77 mm from liquid surface or 4.23 mm from ice surface.

STEADY STATE CONDUCTION IN CYLINDERS

PROBLEM 2.13

The heat conduction equation in cylindrical coordinates is

$$\rho c \frac{\partial T}{\partial t} = k \left(\frac{\partial^2 T}{\partial r^2} + \frac{1}{r} \frac{\partial T}{\partial r} + \frac{1}{r^2} \frac{\partial^2 T}{\partial \phi^2} + \frac{\partial^2 T}{\partial z^2} \right) + \dot{q}'''_G$$

(a) Simplify this equation by eliminating terms equal to zero for the case of steady-state heat flow without sources or sinks around a right-angle corner such as the one in the accompanying sketch. It may be assumed that the corner extends to infinity in the direction perpendicular to the page. (b) Solve the resulting equation for the temperature distribution by substituting the boundary condition. (c) Determine the rate of heat flow from T_1 to T_2 . Assume $k = 1 \text{ W/(m K)}$ and unit depth.

GIVEN

- Steady state conditions
- Right-angle corner as shown below
- No sources or sinks
- Thermal conductivity (k) = 1 W/(m K)

FIND

- Simplified heat conduction equation
- Solution for the temperature distribution
- Rate of heat flow from T_1 to T_2

ASSUMPTIONS

- Corner extends to infinity perpendicular to the paper
- No heat transfer in the z direction
- Heat transfer through the insulation is negligible

SKETCH

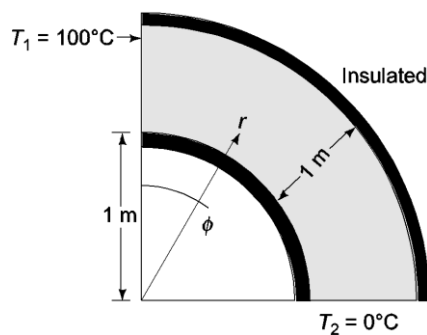

SOLUTION

The boundaries of the region are given by

$$1 \text{ m} \leq r \leq 2 \text{ m}$$

$$0 \leq \phi \leq \frac{\pi}{2}$$

Assuming there is no heat transfer through the insulation, the boundary condition is

$$\frac{\partial T}{\partial r} = 0 \text{ at } r = 1 \text{ m}$$

$$\frac{\partial T}{\partial r} = 0 \text{ at } r = 2 \text{ m}$$

$$T_1 = 100^\circ\text{C at } \phi = 0$$

$$T_2 = 0^\circ\text{C at } \phi = \frac{\pi}{2}$$

(a) The conduction equation is simplified by the following

Steady state

$$\frac{\partial T}{\partial t} = 0$$

No sources or sinks

$$q_k = 0$$

No heat transfer in the z direction

$$\frac{\partial^2 T}{\partial z^2} = 0$$

Since $\frac{\partial T}{\partial r} = 0$ over both boundaries, $\frac{\partial T}{\partial r} = 0$ throughout the region

(Maximum principle); therefore, $\frac{\partial^2 T}{\partial r^2} = 0$ throughout the region also.

Substituting these simplifications into the conduction equation

$$0 = k \left(0 + 0 + \frac{1}{r^2} \frac{\partial^2 T}{\partial \phi^2} + 0 \right)$$

$$\frac{\partial^2 T}{\partial \phi^2} = 0$$

(b) Integrating twice

$$T = c_1 \phi + c_2$$

The boundary condition can be used to evaluate the constants

$$\text{At } \phi = 0, T = 100^\circ\text{C} : 100^\circ\text{C} = c_2$$

$$\text{At } \phi = \frac{\pi}{2}, T = 0^\circ\text{C} : 0^\circ\text{C} = c_1 (\pi/2) + 100^\circ\text{C}$$

$$c_1 = -\frac{200}{\pi} \text{ }^\circ\text{C}$$

Therefore, the temperature distribution is

$$T(\phi) = 100 - \frac{200^\circ\text{C}}{\pi} \phi^\circ\text{C}$$

(c) Consider a slice of the corner as follow

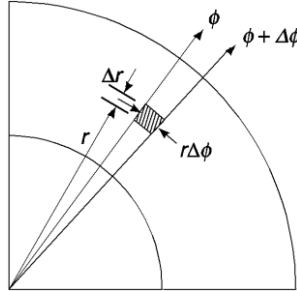

The heat transfer flux through the shaded element in the ϕ direction is

$$q'' = \frac{-k \Delta T}{\text{thickness}} = \frac{-k(T_\phi - T_{\phi+\Delta\phi})}{r \Delta\phi}$$

In the limit as $\Delta\phi \rightarrow 0$, $q'' = -k \frac{dT}{r d\phi}$

Multiplying by the surface area $drdz$ and integrating along the radius

$$q = \int_{r_1}^{r_o} q'' drdz = \frac{200^\circ\text{C}}{\pi} k \int_{r_1}^{r_o} \frac{dr}{r} = \frac{200^\circ\text{C}}{\pi} k \ln \frac{r_o}{r_1}$$

$$q = \frac{200^\circ\text{C}}{\pi} k [1 \text{ W}/(\text{m K})] \ln(2 \text{ m}/1 \text{ m}) = 44.1 \text{ W/m} \quad 44.1 \text{ W per meter in the } z \text{ direction}$$

COMMENTS

Due to the boundary conditions, the heat flux direction is normal to radial lines.

PROBLEM 2.14

Calculate the rate of heat loss per foot and the thermal resistance for a 15 cm schedule 40 steel pipe covered with a 7.5 cm thick layer of 85% magnesia. Superheated steam at 150°C flows inside the pipe [$\bar{h}_c = 170 \text{ W}/(\text{m}^2 \text{ K})$] and still air at 16°C is on the outside [$\bar{h}_c = 30 \text{ W}/(\text{m}^2 \text{ K})$].

GIVEN

A 6 in. standard steel pipe covered with 85% magnesia
Magnesia thickness = 15 cm = 0.15 m
Superheated steam at $T_s = 150^\circ\text{C}$ flows inside the pipe
Surrounding air temperature (T_∞) = 17°C
Heat transfer coefficients

- Inside (\bar{h}_{ci}) = 170 W/(m² K)
- Outside (\bar{h}_{co}) = 30 W/(m² K)

FIND

- (a) The thermal resistance (R)
- (b) The rate of heat loss per foot (q/L)

ASSUMPTIONS

Constant thermal conductivity
The pipe is made of 1% carbon steel

SKETCH

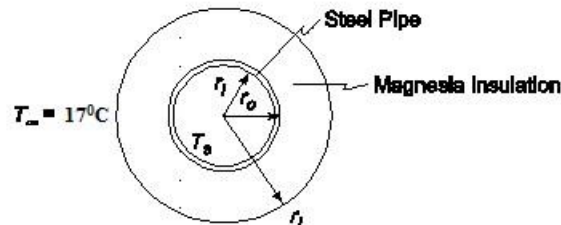

PROPERTIES AND CONSTANTS

From Appendix 2, Tables 10, 11, and 41

For a 6 in. schedule 40 pipe

- Inside diameter (D_i) = 6.065 in. = 0.154 m
- Outside diameter (D_o) = 6.625 in. = 0.1683 m

Thermal Conductivities

- 85% Magnesia (k_I) = 0.059 W/(m K) at 20°C
- 1% Carbon steel (k_s) = 43 W/(m K) at 20°C

SOLUTION

The thermal circuit for the insulated pipe is shown below

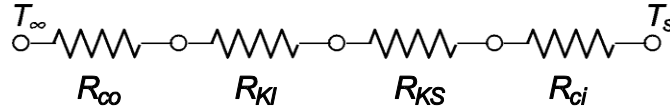

(a) The values of the individual resistances can be calculated using Equations (1.14) and (2.39)

$$R_{co} = \frac{1}{h_{co} A_o} = \frac{1}{h_{co} \pi D_o L} = \frac{1}{[30 \text{ W}/(\text{m}^2 \text{ K})] \pi (0.1683 + 0.075) \text{ m} * L} = \frac{1}{L} 0.04361 \text{ (m K)/W}$$

$$R_{kl} = \frac{\ln\left(\frac{r_i}{r_o}\right)}{2\pi L k_i} = \frac{\ln\left(\frac{(0.1683 + 0.075) \text{ m}}{0.1683 \text{ m}}\right)}{2\pi * L * 0.059 \text{ W}/(\text{m}^2 \text{ K})} = \frac{1}{L} 0.9942 \text{ (m K)/W}$$

$$R_{ks} = \frac{\ln\left(\frac{r_o}{r_i}\right)}{2\pi L k_s} = \frac{\ln\left(\frac{0.1683}{0.154}\right)}{2\pi * 43 \text{ W}/(\text{m} \text{ K})} = \frac{1}{L} 0.000329 \text{ (m K)/W}$$

$$R_{ci} = \frac{1}{h_{ci} A_i} = \frac{1}{h_{ci} \pi D_i L} = \frac{1}{[170 \text{ W}/(\text{m}^2 \text{ K})] \pi (0.154) L} = \frac{1}{L} 0.01216 \text{ (m K)/W}$$

The total resistance is

$$R_{\text{total}} = R_{co} + R_{kl} + R_{ks} + R_{ci}$$

$$R_{\text{total}} = \frac{1}{L} (0.04361 + 0.9942 + 0.00329 + 0.01216) \text{ (m K)/W}$$

$$R_{\text{total}} = \frac{1}{L} 1.05326 \text{ (m K)/W}$$

(b) The rate of heat transfer is given by

$$q = \frac{\Delta T}{R_{\text{total}}} = \frac{150^\circ \text{C} - 17^\circ \text{C}}{\frac{1}{L} 1.05326 \text{ (mK)/W}}$$

$$\therefore \frac{q}{L} = 126.27 \text{ W/m}$$

COMMENTS

Note that almost all of the thermal resistance is due to the insulation and that the thermal resistance of the steel pipe is negligible.

PROBLEM 2.15

Suppose that a pipe carrying a hot fluid with an external temperature of T_i and outer radius r_i is to be insulated with an insulation material of thermal conductivity k and outer radius r_o . Show that if the convective heat transfer coefficient on the outside of the insulation is h and the environmental temperature is T_∞ , the addition of insulation can actually increase the rate of heat loss if $r_o < k/h$ and that maximum heat loss occurs when $r_o = k/h$. This radius, r_c , is often called the critical radius.

GIVEN

- An insulated pipe
- External temperature of the pipe = T_i
- Outer radius of the pipe = r_i
- Outer radius of insulation = r_o
- Thermal conductivity = k
- Ambient temperature = T_∞
- Convective heat transfer coefficient = \bar{h}

FIND

Show that

- (a) The insulation can increase the heat loss if $r_o < k/\bar{h}$
- (b) Maximum heat loss occurs when $r_o = k/\bar{h}$

ASSUMPTIONS

- The system has reached steady state
- The thermal conductivity does not vary appreciably with temperature
- Conduction occurs in the radial direction only

SKETCH

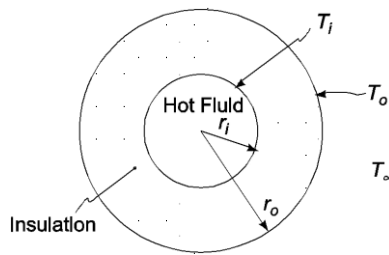

SOLUTION

Radial conduction for a cylinder of length L is given by Equation (2.37)

$$q_k = 2 \pi L k \frac{T_i - T_o}{\ln(r_o/r_i)}$$

Convection from the outer surface of the cylinder is given by Equation (1.10)

$$q_c = \bar{h}_c A \Delta T = \bar{h} 2 \pi r_o L (T_o - T_\infty)$$

For steady state

$$q_k = q_c$$

$$2 \pi L k \frac{T_i - T_o}{\ln(r_o/r_i)} = \bar{h} 2 \pi r_o L (T_o - T_\infty)$$

$$\ln(r_0/r_i)$$

The outer wall temperature, T_o , is an unknown and must be eliminated from the equation
Solving for $T_i - T_o$

$$T_i - T_o = \frac{\bar{h} r_o}{k} \ln \frac{r_o}{r_i} (T_o - T_\infty)$$

$$T_i - T_\infty = (T_i - T_o) + (T_o - T_\infty) = \frac{\bar{h} r_o}{k} \ln \frac{r_o}{r_i} (T_o - T_\infty) + (T_o - T_\infty)$$

$$T_i - T_\infty = \left(\frac{\bar{h} r_o \ln \frac{r_o}{r_i}}{k} + 1 \right) (T_o - T_\infty)$$

or

$$T_o - T_\infty = \frac{\frac{\bar{h} r_o \ln \frac{r_o}{r_i}}{k} + 1}{1 + \frac{\bar{h} r_o \ln \frac{r_o}{r_i}}{k}}$$

Substituting this into the convection equation

$$q = q_c = \bar{h} 2 \pi r_o L \left[\frac{T_i - T_\infty}{1 + \frac{\bar{h} r_o \ln \frac{r_o}{r_i}}{k}} \right] \Rightarrow q = \frac{T_i - T_\infty}{\left(\frac{1}{2\pi r_o L \bar{h}} + \frac{\ln \frac{r_o}{r_i}}{2\pi L k} \right)}$$

Examining the above equation, the heat transfer rate is a maximum when the term

$\left(\frac{1}{2\pi r_o L \bar{h}} + \frac{\ln \frac{r_o}{r_i}}{2\pi L k} \right)$ is a minimum, which occurs when its differential with respect to r_o is zero

$$\frac{1}{2\pi k L} \frac{d}{dr_o} \left(\frac{k}{r_o h} + \ln \frac{r_o}{r_i} \right) = 0 \Rightarrow \frac{k}{h} \frac{d}{dr_o} \left(\frac{1}{r_o} \right) + \frac{d}{dr_o} \ln \frac{r_o}{r_i} = 0$$

$$\frac{k}{h} \left(-\frac{1}{r_o^2} \right) + \frac{1}{r_o} = 0 \Rightarrow r_o = \frac{k}{h}$$

The second derivative of the denominator is

$$\frac{k}{h} \frac{2}{r_o^3} - \frac{1}{r_o^2}$$

which is greater than zero at $r_o = k/h$, therefore $r_o = k/h$ is a true minimum and the maximum heat loss occurs when the diameter is $r_o = k/h$. Adding insulation to a pipe with a radius less than k/h will increase the heat loss until the radius of k/h is reached.

COMMENTS

A more detailed solution taking into account the dependence of h_c on the temperature has been obtained by Sparrow and Kang, Int. J. Heat Mass Transf., 28: 2049–2060, 1985.

PROBLEM 2.16

A solution with a boiling point of 82°C boils on the outside of a 2.5 cm tube with a No. 14 BWG gauge wall. On the inside of the tube flows saturated steam at 40 kPa(abs). The convection heat transfer coefficients are $8.5 \text{ kW}/(\text{m}^2 \text{ K})$ on the steam side and $6.2 \text{ kW}/(\text{m}^2 \text{ K})$ on the exterior surface. Calculate the increase in the rate of heat transfer if a copper tube is used instead of a steel tube.

GIVEN

- Tube with saturated steam on the inside and solution boiling at 82°C outside
- Tube specification: 1 in. No. 14 BWG gauge wall
- Saturated steam in the pipe is at 40 kPa(abs)
- Convective heat transfer coefficients
 - Steam side (\bar{h}_{ci}) : $8.5 \text{ kW}/(\text{m}^2 \text{ K})$
 - Exterior surface (\bar{h}_{co}) : $6.2 \text{ kW}/(\text{m}^2 \text{ K})$

FIND

- The increase in the rate of heat transfer for a copper over a steel tube

ASSUMPTIONS

- The system is in steady state
- Constant thermal conductivities

SKETCH

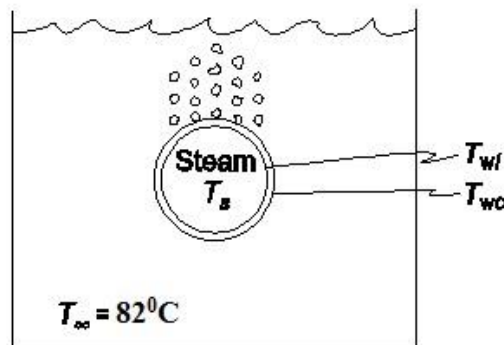

PROPERTIES AND CONSTANTS:

From Appendix 2, Tables 10, 12, 13 and 42

- Temperature of saturated steam at 60 psia (T_s) = 144°C
- Thermal conductivities
 - Copper (k_c) = $391 \text{ W}/(\text{m K})$ at 127°C
 - 1% Carbon steel (k_s) = $43 \text{ W}/(\text{m K})$ at 20°C
- Tube inside diameter (D_i) = 0.0212 m

SOLUTION

The thermal circuit for the tube is shown below

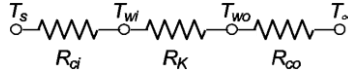

The individual resistances are

$$R_{ci} = \frac{1}{h_{ci} A_i} = \frac{1}{h_{ci} \pi D_i L} = \frac{1}{[8500 \text{ W}/(\text{m}^2 \text{ K})] \pi (0.0212 \text{ m}) L} = \frac{1}{L} 0.001766 \text{ (m K)/W}$$

$$R_{co} = \frac{1}{h_{co} A_o} = \frac{1}{h_{co} \pi D_o L} = \frac{1}{[6200 \text{ W}/(\text{m K})] \pi (0.025 \text{ m}) L} = \frac{1}{L} 0.00205 \text{ (m K)/W}$$

$$R_{kc} = \frac{\ln \frac{r_o}{r_i}}{2\pi L k_c} = \frac{\ln \left(\frac{0.025 \text{ m}}{0.0212 \text{ m}} \right)}{2\pi L * 391 \text{ W}/(\text{m K})} = \frac{1}{L} 0.000067 \text{ (m K)/W}$$

$$R_{ks} = \frac{\ln \frac{r_o}{r_s}}{2\pi L k_s} = \frac{\ln \left(\frac{0.025 \text{ m}}{0.0212 \text{ m}} \right)}{2\pi L * 43 \text{ W}/(\text{m K})} = \frac{1}{L} 0.00061 \text{ (m K)/W}$$

The rate of heat transfer is

$$q = \frac{\Delta T}{R_{\text{total}}} = \frac{T_s - T_{\infty}}{R_{ci} + R_k + R_{co}}$$

For the copper tube

$$\frac{q_c}{L} = \frac{144^\circ\text{C} - 82^\circ\text{C}}{(0.001766 + 0.00205 + 0.000067) \text{ (mK)}/\text{W}} = 15967 \text{ W}$$

For the steel tube

$$\frac{q_s}{L} = \frac{144^\circ\text{C} - 82^\circ\text{C}}{(0.001766 + 0.00205 + 0.00061) \text{ (mK)}/\text{W}} = 14,008 \text{ W}$$

The increase in the rate of heat transfer per unit length with the copper tube is

$$\text{Increase} = \frac{q_c}{L} - \frac{q_s}{L} = 1958 \text{ W}$$

$$\text{Per cent increase} = \frac{1958}{14,008} \times 100 = 14\%$$

COMMENTS

The choice of tubing material is significant in this case because the convective heat transfer resistances are small making the conductive resistant a significant portion of the overall thermal resistance.

PROBLEM 2.17

Steam having a quality of 98% at a pressure of $1.37 \times 10^5 \text{ N/m}^2$ is flowing at a velocity of 1 m/s through a steel pipe of 2.7 cm OD and 2.1 cm ID. The heat transfer coefficient at the inner surface, where condensation occurs, is $567 \text{ W/(m}^2 \text{ K)}$. A dirt film at the inner surface adds a unit thermal resistance of $0.18 \text{ (m}^2 \text{ K)/W}$. Estimate the rate of heat loss per meter length of pipe if; (a) the pipe is bare, (b) the pipe is covered with a 5 cm layer of 85% magnesia insulation. For both cases assume that the convective heat transfer coefficient at the outer surface is $11 \text{ W/(m}^2 \text{ K)}$ and that the environmental temperature is 21°C . Also estimate the quality of the steam after a 3-m length of pipe in both cases.

GIVEN

A steel pipe with steam condensing on the inside

Diameters

- Outside (D_o) = 2.7 cm = 0.027 m
- Inside (D_i) = 2.1 cm = 0.021 m

Velocity of the steam (V) = 1 m/s

Initial steam quality (X_i) = 98%

Steam pressure = $1.37 \times 10^5 \text{ N/m}^2$

Heat transfer coefficients

- Inside (h_{ci}) = $567 \text{ W/(m}^2 \text{ K)}$
- Outside (h_{co}) = $11 \text{ W/(m}^2 \text{ K)}$

Thermal resistance of dirt film on inside surface (R_f) = $0.18 \text{ (m}^2 \text{ K)/W}$

Ambient temperature (T_∞) = 21°C

FIND

- The heat loss per meter (q/L) and the change in the quality of the steam per 3 m length for
(a) A bare pipe
(b) A pipe insulated with 85% Magnesia: thickness (L_i) = 0.05 m

ASSUMPTIONS

Steady state conditions exist

Constant thermal conductivity

Steel is 1% carbon steel

Radiative heat transfer from the pipe is negligible

Neglect the pressure drop of the steam

SKETCH

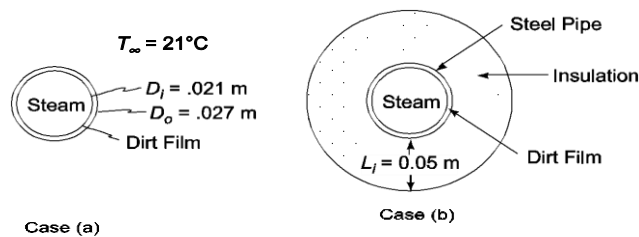

PROPERTIES AND CONSTANTS

- From **Appendix 2, Tables 10, 11, and 13**
- The thermal conductivities are:
1% carbon steel (k_s) = 43 W/(m K) at 20°C
85% Magnesia (k_i) = 0.059 W/(m K) at 20°C
- For saturated steam at $1.37 \times 10^5 \text{ N/m}^2$:

Temperature (T_{st}) = 107°C
 Heat of vaporization (h_{fg}) = 2237 kJ/kg
 Specific volume (v_s) = 1.39 m³/kg

SOLUTION

(a) The thermal circuit for the uninsulated pipe is shown below

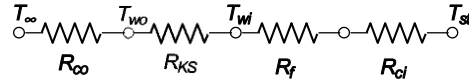

• Evaluating the individual resistances

$$R_{co} = \frac{1}{h_{co} A_o} = \frac{1}{h_{co} \pi D_o L} = \frac{1}{[11 \text{ W/(m K)}] \pi (0.027 \text{ m}) L} = \frac{1}{L} 1.072 \text{ (mK)/W}$$

$$R_{ks} = \frac{\ln \frac{r_o}{r_i}}{2\pi L k_i} = \frac{\ln \left(\frac{0.027}{0.021} \right)}{2\pi [43 \text{ W/(mK)}] L} = \frac{1}{L} 0.00093 \text{ (mK)/W}$$

$$R_f = \frac{r_f}{A} = \frac{r_f}{2\pi D L} = \frac{1}{L} \frac{0.18 \text{ m}^2 \text{K/W}}{\pi (0.021 \text{ m})} = \frac{1}{L} 2.728 \text{ (mK)/W}$$

$$R_{ci} = \frac{1}{h_{ci} A_i} = \frac{1}{h_{ci} \pi D_i L} = \frac{1}{[567 \text{ W/(m}^2 \text{ K)}] \pi (0.021 \text{ m}) L} = \frac{1}{L} 0.0267 \text{ (mK)/W}$$

• The rate of heat transfer through the pipe is

$$q = \frac{\Delta T}{R_{total}} = \frac{T_{st} - T_{\infty}}{R_{co} + R_{ks} + R_f + R_{ci}}$$

$$\frac{q}{L} = \frac{107^\circ\text{C} - 21^\circ\text{C}}{(1.072 + 0.00093 + 2.728 + 0.267) \text{ (mK)/W}} = 22.5 \text{ W/m}$$

• The total rate of transfer of a three meter section of the pipe is

$$q = 22.5 \text{ W/m (3 m)} = 67.4 \text{ W}$$

• The mass flow rate of the steam in the pipe is

$$\dot{m}_s = \frac{A_i V}{v_s} = \frac{\pi \bar{D}_i^2 V}{4 v_s} = \frac{\pi (0.021 \text{ m})^2 (1 \text{ m/s})}{4 (1.39 \text{ m}^3/\text{kg}) (1 \text{ kg}/1000 \text{ g})} = 0.249 \text{ g/s}$$

• The mass rate of steam condensed in a 3 meter section of the pipe is equal to the rate of heat transfer divided by the heat of vaporization of the steam

$$\dot{m}_c = \frac{q}{h_{fg}} = \frac{67.4 \text{ W}}{2237 \text{ J/g(Ws/J)}} = 0.030 \text{ g/s}$$

- The quality of the saturated steam is the fraction of the steam which is vapor. The quality of the steam after a 3 meter section, therefore, is

$$X_i = \frac{(\text{original vapor mass}) - (\text{mass of vapor condensed})}{\text{total mass of steam}} = \frac{X_i \dot{m}_s - \dot{m}_c}{\dot{m}_s}$$

$$X_i = \frac{0.98 (0.249 \text{ g/s}) - 0.030 \text{ g/s}}{0.249 \text{ g/s}} = 0.86 = 86\%$$

- The quality of the steam changed by 12%.
- The thermal circuit for the pipe with insulation is shown below

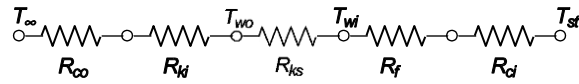

- The convective resistance on the outside of the pipe is different than that in part (a) because it is based on the outer area of the insulation

$$R_{co} = \frac{1}{h_{co} A_o} = \frac{1}{\bar{h}_{co} \pi (D_o + 2L_i) L} = \frac{1}{[11 \text{ W}/(\text{m}^2 \text{ K})] \pi (0.027 \text{ m} + 0.1 \text{ m}) L} = \frac{1}{L} 0.228 \text{ (mK)/W}$$

- The thermal resistance of the insulation is 0.0

$$R_{ki} = \frac{\ln\left(\frac{D_o + 2L_i}{r_i}\right)}{2 \pi L k_i} = \frac{\ln\left(\frac{27 + 0.1}{0.027}\right)}{2 \pi [0.059 \text{ W}/(\text{m K})] L} = \frac{1}{L} 4.18 \text{ (mK)/W}$$

- The rate of heat transfer is

$$q = \frac{\Delta T}{R_{\text{total}}} = \frac{T_{si} - T_{\infty}}{R_{\infty} + R_{ki} + R_{ks} + R_f + R_{ci}}$$

$$\therefore \frac{q}{L} = \frac{107^\circ\text{C} - 21^\circ\text{C}}{(0.228 + 4.18 + 0.00093 + 2.728 + 0.0267) \text{ (mK)/W}} = 12.0 \text{ W/m}$$

- Therefore, the rate of steam condensed in 3 meters is

$$\dot{m}_c = \frac{q}{h_{fg}} = \frac{12.0 * 3 \text{ W}}{2237 \text{ J/g (Ws/J)}} = 0.016 \text{ g/s}$$

- The quality of the steam after 3 meters of pipe is

$$X_f = \frac{0.98 (0.249 \text{ g/s}) - 0.016 \text{ g/s}}{0.249 \text{ g/s}} = 0.92 = 92\%$$

- The change in the quality of the steam is 6%.

COMMENTS

- Notice that the resistance of the steel pipe and the convective resistance on the inside of the pipe are negligible compared to the other resistances.
- The resistance of the dirt film is the dominant resistance for the uninsulated pipe.

PROBLEM 2.18

Estimate the rate of heat loss per unit length from a 5 cm *ID*, 6 cm *OD* steel pipe covered with high temperature insulation having a thermal conductivity of 0.11 W/(m K) and a thickness of 1.2 cm. Steam flows in the pipe. It has a quality of 99% and is at 150°C. The unit thermal resistance at the inner wall is 0.0026 (m² K)/W, the heat transfer coefficient at the outer surface is 17 W/(m² K), and the ambient temperature is 16°C.

GIVEN

Insulated, steam filled steel pipe

Diameters

- *ID* of pipe (D_i) = 5 cm = 0.05 m
- *OD* of pipe (D_o) = 6 cm = 0.06 m

Thickness of insulation (L_i) = 1.2 cm = 0.012 m

Steam quality = 99%

Steam temperature (T_s) = 150°C

Unit thermal resistance at inner wall ($A R_i$) = 0.026 (m² K)/W

Heat transfer coefficient at outer wall (h_o) = 17 W/(m² K)

Ambient temperature (T_∞) = 16°C

Thermal conductivity of the insulation (k_i) = 0.11 W/(m K)

FIND

Rate of heat loss per unit length (q/L)

ASSUMPTIONS

1% carbon steel

Constant thermal conductivities

Steady state conditions

SKETCH

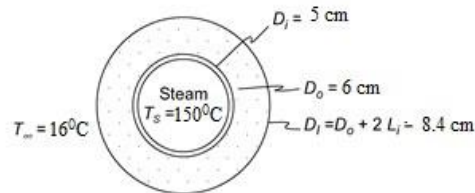

PROPERTIES AND CONSTANTS

From Appendix 2, Table 10

The thermal conductivity of 1% carbon steel (k_s) = 43 W/(m² °K) at 20 °C

SOLUTION

The outer diameter of the insulation (D_i) = 6 cm + 2(1.2 cm) = 8.4 cm

The thermal circuit of the insulated pipe is shown below

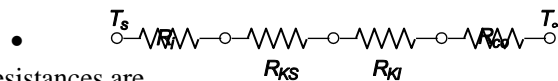

The values of the individual resistances are

$$R_i = \frac{A R_i}{A_i} = \frac{A R_i}{\pi D_i L} = \frac{0.0026 (\text{m}^2 \text{ K})/\text{W}}{\pi L (0.05 \text{ m})} = \frac{1}{L} 0.01655 (\text{m K})/\text{W}$$

$$R_{ks} = \frac{\ln\left(\frac{D_o}{D_i}\right)}{2\pi Lk_s} = \frac{\ln\left(\frac{0.06m}{0.05m}\right)}{2\pi * L * 43W/(m K)} = \frac{1}{L} 0.000675 \text{ (m K)/W}$$

$$R_{kl} = \frac{\ln\left(\frac{D_l}{D_o}\right)}{2\pi Lk_i} = \frac{\ln\left(\frac{0.084m}{0.06m}\right)}{2\pi L * 0.11W/(m K)} = \frac{1}{L} 0.487 \text{ (m K)/W}$$

$$R_{co} = \frac{1}{h_{co} A_o} = \frac{1}{h_{co} \pi D_l L} = \frac{1}{[17W/(mK)]\pi(0.084m)} L = \frac{1}{L} 0.223 \text{ (m K)/W}$$

The rate of heat transfer is

$$q = \frac{\Delta T}{R_{total}} = \frac{T_s - T_\infty}{R_i + R_{ks} + R_{kl} + R_{co}}$$

$$\therefore \frac{q}{L} = \frac{150^\circ C - 16^\circ C}{(0.01655 + 0.000675 + 0.487 + 0.223)(h \text{ ft } ^\circ F)/\text{Btu}} = 184 \text{ W/m}$$

PROBLEM 2.19

The rate of heat flow per unit length q/L through a hollow cylinder of inside radius r_i and outside radius r_o is

$$q/L = (\bar{A} k \Delta T)/(r_o - r_i)$$

where $A = 2\pi (r_o - r_i)/\ln(r_o/r_i)$. Determine the per cent error in the rate of heat flow if the arithmetic mean area $\pi (r_o + r_i)$ is used instead of the logarithmic mean area A for ratios of outside to inside diameters (D_o/D_i) of 1.5, 2.0, and 3.0. Plot the results.

GIVEN

- A hollow cylinder
- Inside radius = r_i
- Outside radius = r_o
- Heat flow per unit length as given above

FIND

- Per cent error in the rate of heat flow if the arithmetic rather than the logarithmic mean area is used for ratios of outside to inside diameters of 1.5, 2.0, and 3.0.
- Plot the results

ASSUMPTIONS

- Radial conduction only
- Constant thermal conductivity
- Steady state prevails

SKETCH

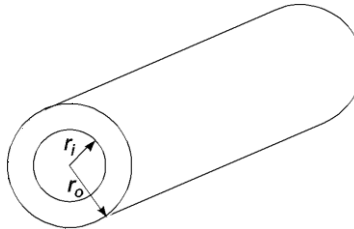

SOLUTION

The rate of heat transfer per unit length using the logarithmic mean area is

$$\left(\frac{q}{L}\right)_{\log} = \frac{2\pi(r_o - r_i)}{\ln\left(\frac{r_o}{r_i}\right)} \frac{k\Delta T}{r_o - r_i} = \frac{2\pi k\Delta T}{\ln\left(\frac{r_o}{r_i}\right)}$$

The rate of heat transfer per unit length using the arithmetic mean area is

$$\left(\frac{q}{L}\right)_{\text{arith}} = \pi (r_o + r_i) \frac{k\Delta T}{r_o - r_i} = \pi k \Delta T \frac{r_o + r_i}{r_o - r_i}$$

The per cent error is

$$\% \text{ error} = \frac{\left(\frac{q}{L}\right)_{\log} - \left(\frac{q}{L}\right)_{\text{arith}}}{\left(\frac{q}{L}\right)_{\log}} \times 100 = \frac{\frac{2\pi k \Delta T}{\ln \frac{r_o}{r_i}} - \pi k \Delta T \frac{r_o + r_i}{r_o - r_i}}{\frac{2\pi k \Delta T}{\ln \frac{r_o}{r_i}}} \times 100$$

$$\% \text{ error} = \left[1 - \frac{1}{2} \ln \left(\frac{r_o}{r_i} \right) \frac{\left(\frac{r_o}{r_i} + 1 \right)}{\left(\frac{r_o}{r_i} - 1 \right)} \right] \times 100$$

For a ratio of outside to inside diameters of 1.5

$$\% \text{ error} = \left[1 - \frac{1}{2} \ln(1.5) \left(\frac{1.5 + 1}{1.5 - 1} \right) \right] \times 100 = -1.37\%$$

The percent errors for the other diameter ratios can be calculated in a similar manner with the following results

Diameter ratio	% Error
1.5	-1.37
2.0	-3.97
3.0	-9.86

(b)

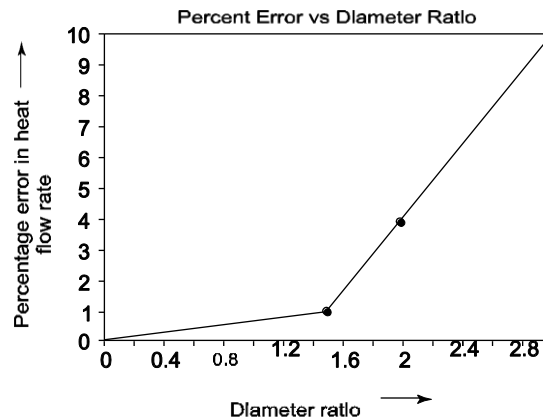

COMMENTS

For diameter ratios less than 2, use of the arithmetic mean area will not introduce more than a 4% error.

PROBLEM 2.20

A 2.5-cm-OD, 2-cm-ID copper pipe carries liquid oxygen to the storage site of a space shuttle at -183°C and $0.04\text{ m}^3/\text{min}$. The ambient air is at 21°C and has a dew point of 10°C . How much insulation with a thermal conductivity of $0.02\text{ W}/(\text{m K})$ is needed to prevent condensation on the exterior of the insulation if $h_c + h_r = 17\text{ W}/(\text{m}^2\text{ K})$ on the outside?

GIVEN

- Insulated copper pipe carrying liquid oxygen
- Inside diameter (D_i) = 2 cm = 0.02 m
- Outside diameter (D_o) = 2.5 cm = 0.025 m
- LOX temperature (T_{ox}) = -183°C
- LOX flow rate (m_{ox}) = $0.04\text{ m}^3/\text{min}$
- Thermal conductivity of insulation (k_i) = $0.02\text{ W}/(\text{m K})$
- Exterior heat transfer coefficients ($h_o = h_c + h_r$) = $17\text{ W}/(\text{m}^2\text{ K})$
- Ambient air temperature (T_{∞}) = 21°C
- Ambient air dew point (T_{dp}) = 10°C

FIND

Thickness of insulation (L) needed to prevent condensation

ASSUMPTIONS

- Steady-state conditions have been reached
- The thermal conductivity of the insulation does not vary appreciably with temperature
- Radial conduction only
- The thermal resistance between the inner surface of the pipe and the liquid oxygen is negligible, therefore $T_{wi} = T_{ox}$

SKETCH

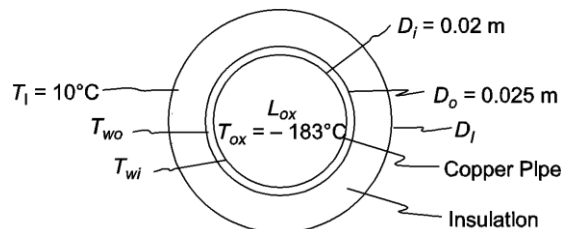

PROPERTIES AND CONSTANTS

From Appendix 2, Table 12, thermal conductivity of copper (k_c) = $401\text{ W}/(\text{m K})$ at 0°C

SOLUTION

The thermal circuit for the pipe is shown below

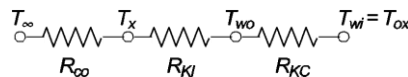

The rate of heat transfer from the pipe is

$$q = \frac{\Delta T}{R_{\text{total}}} = \frac{T_{\infty} - T_{ox}}{\frac{1}{h_o A_I} + \frac{\ln\left(\frac{D_o}{D_i}\right)}{2\pi L k_c} + \frac{\ln\left(\frac{D_i}{D_o}\right)}{2\pi L k_I}}$$

The rate of heat transfer by convection and radiation from the outer surface of the pipe is

$$q = \frac{\Delta T}{R_o} = \frac{T_{\infty} - T_I}{\frac{1}{h_o A_o}} \quad T_I$$

Equating these two expressions

$$\frac{T_{\infty} - T_{ox}}{\frac{1}{h_o A_I} + \frac{\ln\left(\frac{D_o}{D_i}\right)}{2\pi L k_c} + \frac{\ln\left(\frac{D_i}{D_o}\right)}{2\pi L k_I}} = \frac{T_{\infty} - T_I}{\frac{1}{h_o A_o}}$$

$$\frac{T_{\infty} - T_{ox}}{T_{\infty} - T_I} = \frac{\frac{1}{\pi h_o D_o L} + \frac{\ln\left(\frac{D_o}{D_i}\right)}{2\pi L k_c} + \frac{\ln\left(\frac{D_i}{D_o}\right)}{2\pi L k_I}}{\frac{1}{h_o \pi D_o L}}$$

$$\frac{T_{\infty} - T_{ox}}{T_{\infty} - T_I} = 1 + \frac{h_o D_o}{2 L} \left(\frac{\ln\left(\frac{D_o}{D_i}\right)}{k_I} + \frac{\ln\left(\frac{D_i}{D_o}\right)}{k_c} \right)$$

$$D_o \left(\frac{\ln\left(\frac{D_o}{D_i}\right)}{k_I} - \frac{\ln\left(\frac{D_o}{D_i}\right)}{k_I} + \frac{\ln\left(\frac{D_i}{D_o}\right)}{k_c} \right) = \frac{2}{h_o} \left(\frac{T_{\infty} - T_{ox}}{T_{\infty} - T_I} - 1 \right)$$

$$D_o \left(\frac{\ln\left(\frac{D_o}{D_i}\right)}{0.02 \text{ W/(m K)}} - \frac{\ln(0.025)}{0.02 \text{ W/(m K)}} + \frac{\ln\left(\frac{0.025}{0.02}\right)}{401 \text{ W/(m K)}} \right) = \frac{2}{17 \text{ W/(m}^2 \text{ K)}}$$

$$\left(\frac{21^\circ\text{C} - (183^\circ\text{C})}{21^\circ\text{C} - 10^\circ\text{C}} - D_o \left(\frac{\ln D_o}{0.02} - 184.4 + 0.00056 \right) \right) = 2.064 \text{ (m}^2 \text{ K)/W}$$

Solving this by trial and error

$$D_o = 0.054 \text{ m} = 5.4 \text{ cm}$$

Therefore, the thickness of the insulation is

$$L = \frac{D_o - D_i}{2} = \frac{5.4 \text{ cm} - 2.5 \text{ cm}}{2} = 1.5 \text{ cm}$$

COMMENTS

Note that the thermal resistance of the copper pipe is negligible compared to that of the insulation.

PROBLEM 2.21

A salesperson for insulation material claims that insulating exposed steam pipes in the basement of a large hotel will be cost effective. Suppose saturated steam at 5.7 bars flows through a 30-cm-OD steel pipe with a 3 cm wall thickness. The pipe is surrounded by air at 20°C. The convective heat transfer coefficient on the outer surface of the pipe is estimated to be 25 W/(m² K). The cost of generating steam is estimated to be \$5 per 10⁹ J and the salesman offers to install a 5 cm thick layer of 85% magnesia insulation on the pipes for \$200/m or a 10-cm-thick layer for \$300/m. Estimate the payback time for these two alternatives assuming that the steam line operates all year long and make a recommendation to the hotel owner. Assume that the surface of the pipe as well as the insulation have a low emissivity and radiative heat transfer is negligible.

GIVEN

- Steam pipe in a hotel basement
- Pipe outside diameter (D_o) = 30 cm = 0.3 m
- Pipe wall thickness (L_s) = 3 cm = 0.03 m
- Surrounding air temperature (T_∞) = 20°C
- Convective heat transfer coefficient (h_c) = 25 W/(m² K)
- Cost of steam = \$5/10⁹ J
- Insulation is 85% magnesia

FIND

Payback time for

- (a) Insulation thickness (L_{Ia}) = 5 cm = 0.05 m; Cost = \$200/m
 - (b) Insulation thickness (L_{Ib}) = 10 cm = 0.10 m; Cost = \$300/m
- Make a recommendation to the hotel owner.

ASSUMPTIONS

- The pipe and insulation are black ($\epsilon = 1.0$)
- The convective resistance on the inside of the pipe is negligible, therefore the inside pipe surface temperature is equal to the steam temperature
- The pipe is made of 1% carbon steel
- Constant thermal conductivities

SKETCH

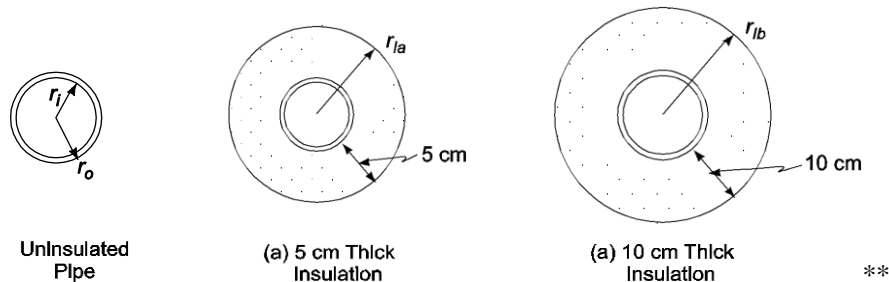

**

PROPERTIES AND CONSTANTS

From Appendix 1, Table 5: The Stefan-Boltzmann constant (σ) = 5.67 × 10⁻⁸ W/(m² K⁴)
 From Appendix 2, Table 10 and 11

- Thermal conductivities: 1% Carbon Steel (k_s) = 43 W/(m K) at 20°C
- 85% Magnesia (k_I) = 0.059 W/(m K) at 20°C

From Appendix 2, Table 13

The temperature of saturated steam at 5.7 bars (T_s) = 156°C

SOLUTION

The rate of heat loss and cost of the uninsulated pipe will be calculated first.

The thermal circuit for the uninsulated pipe is shown below

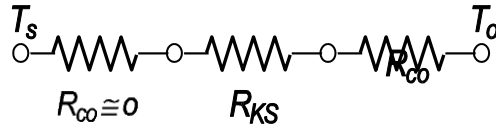

Evaluating the individual resistances,

$$R_{ks} = \frac{\ln\left(\frac{r_o}{r_i}\right)}{2\pi Lk_s} = \frac{\ln\left(\frac{0.15}{0.12}\right)}{2\pi[43\text{ W/(m K)}]} = \frac{1}{L} 0.000826 \text{ (m K)/W}$$

$$R_{co} = \frac{1}{\bar{h}_c A_o} = \frac{1}{\bar{h}_c 2\pi r_o L} = \frac{1}{[25\text{ W/(m}^2\text{ K)}]2\pi(0.15\text{ m}) L} = \frac{1}{L} 0.0424 \text{ (m K)/W}$$

The rate of heat transfer for the uninsulated pipe is

$$q = \frac{\Delta T}{R_{\text{total}}} = \frac{T_s - T_\infty}{R_{ks} + R_{co}}$$

$$\left| \frac{q}{L} = \frac{156^\circ\text{C} - 20^\circ\text{C}}{(0.000826 + 0.0424)(\text{K m})/\text{W}} = 3148 \text{ W/m} \right.$$

The cost to supply this heat loss is

$$\text{cost} = (3148 \text{ w/m}) (\text{J/W s}) (3600 \text{ s/h}) (24 \text{ h/day}) (365 \text{ days/yr}) (\$5/109\text{J}) = \$496/(\text{yr m})$$

For the insulated pipe the thermal circuit is

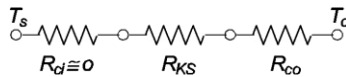

The resistance of the insulation is given by:

$$R_{kla} = \frac{\ln\left(\frac{r_{ia}}{r_o}\right)}{2\pi Lk_I} = \frac{\ln\left(\frac{0.2}{0.15}\right)}{2\pi[0.059\text{ W/(mK)}]} = \frac{1}{L} 0.776 \text{ (m K)/W}$$

$$R_{klb} = \frac{\ln\left(\frac{r_{io}}{r_o}\right)}{2\pi Lk_I} = \frac{\ln\left(\frac{0.25}{0.15}\right)}{2\pi[0.059\text{ W/(mK)}]} = \frac{1}{L} 1.378 \text{ (m K)/W}$$

(a) The rate of heat transfer for the pipe with 5 cm of insulation is

$$q = \frac{\Delta T}{R_{\text{total}}} = \frac{T_s - T_\infty}{R_{ks} + R_{kla} + R_{co}}$$

$$\left| \frac{q}{L} = \frac{156^\circ\text{C} - 20^\circ\text{C}}{(0.000826 + 0.776 + 0.0424)(\text{Km})/\text{W}} = 166 \text{ W/m} \right.$$

The cost of this heat loss is

$$\text{cost} = (166 \text{ w/m}) (\text{J/W s}) (3600 \text{ s/h}) (24 \text{ h/day}) (365 \text{ days/yr}) (\$5/10^9\text{J}) = \$26/\text{yr m}$$

Comparing this cost to that of the uninsulated pipe we can calculate the payback period

$$\text{Payback period} = \frac{\text{Cost of installation}}{\text{uninsulated cost} - \text{insulated cost}} = \frac{\$200 / \text{m}}{\$496 / (\text{yr m}) - \$26 / (\text{yr m})}$$

$$\text{Payback period} = 0.43 \text{ yr} = 5 \text{ months}$$

(b) The rate of heat loss for the pipe with 10 cm of insulation is

$$q = \frac{\Delta T}{R_{\text{total}}} = \frac{T_s - T_\infty}{R_{ks} + R_{kfb} + R_{co}}$$

$$\parallel \frac{q}{L} = \frac{20^\circ\text{C} - 156^\circ\text{C}}{(0.000826 + 1.378 + 0.0424) (\text{Km})/\text{W}} = 95.7 \text{ W/m}$$

The cost of this heat loss

$$\text{cost} = (95.7 \text{ w/m}) (\text{J/W s}) (3600 \text{ s/h}) (24 \text{ h/day}) (365 \text{ days/yr}) (\$5/10^9 \text{ J}) = \$15/\text{yr m}$$

Comparing this cost to that of the uninsulated pipe we can calculate the payback period

$$\text{Payback period} = \frac{\$300 / \text{m}}{\$496 / \text{yr m} - \$15 / \text{yr m}} = 0.62 \text{ yr} = 7.5 \text{ months}$$

COMMENTS

The 5 cm insulation is a better economic investment. The 10 cm insulation still has a short payback period and is the superior environmental investment since it is a more energy efficient design. Moreover, energy costs are likely to increase in the future and justify the investment in thicker insulation.

PROBLEM 2.22

A cylindrical liquid oxygen (LOX) tank has a diameter of 1.22 m, a length of 6.1 m, and hemispherical ends. The boiling point of LOX is -179.4°C . An insulation is sought which will reduce the boil-off rate in the steady state to no more than 11.3 kg/h. The heat of vaporization of LOX is 214 kJ/kg. If the thickness of this insulation is to be no more than 7.5 cm, what would the value of its thermal conductivity have to be?

GIVEN

- Insulated cylindrical tank with hemispherical ends filled with LOX
- Diameter of tank (D_t) = 1.22 m
- Length of tank (L_t) = 6.1 m
- Boiling point of LOX (T_{bp}) = -179.4°C
- Heat of vaporization of LOX (h_{fg}) = 214 kJ/kg
- Steady state boil-off rate (\dot{m}) = 11.2 kg/h
- Maximum thickness of insulation (L) = 7.5 cm = 0.075 m

FIND

- The thermal conductivity (k) of the insulation necessary to maintain the boil-off rate below 11.2 kg/h.

ASSUMPTIONS

- The length given includes the hemispherical ends
- The thermal resistance of the tank is negligible compared to the insulation
- The thermal resistance at the interior surface of the tank is negligible

SKETCH

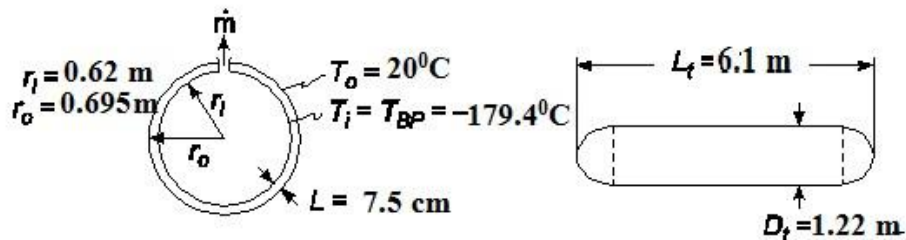

SOLUTION

The tank can be thought of as a sphere (the ends) separated by a cylindrical section, therefore the total heat transfer is the sum of that through the spherical and cylindrical sections. The steady state conduction through a spherical shell with constant thermal conductivity, from Equation (2.50), is

$$q_s = \frac{4\pi K r_o r_i (T_o - T_i)}{r_o - r_i}$$

The rate of steady state conduction through a cylindrical shell, from Equation (2.37), is

$$q_c = 2\pi L_c k \frac{T_o - T_i}{\ln\left(\frac{r_o}{r_i}\right)} \quad (L_c = L_t - 1.22 \text{ m} = 4.88 \text{ m})$$

The total heat transfer through the tank is the sum of these

$$q = q_s + q_c = \frac{4\pi k r_o r_i (T_o - T_i)}{r_o - r_i} + 2\pi L_c k \frac{(T_o - T_i)}{\ln\left(\frac{r_o}{r_i}\right)} = 2\pi k (T_o - T_i) \left[\frac{2r_o r_i}{r_o - r_i} + \frac{L_c}{\ln\left(\frac{r_o}{r_i}\right)} \right]$$

The rate of heat transfer required to evaporate the liquid oxygen at m is $m h_{fg}$, therefore

$$\begin{aligned} \dot{m}_s h_{fg} &= 2\pi k (T_o - T_i) \left[\frac{2r_o r_i}{r_o - r_i} + \frac{L_c}{\ln\left(\frac{r_o}{r_i}\right)} \right] \\ \therefore k &= \frac{m h_{fg}}{2\pi k (T_o - T_i) \left[\frac{2r_o r_i}{r_o - r_i} + \frac{L_c}{\ln\left(\frac{r_o}{r_i}\right)} \right]} \\ k &= \frac{11.3 \text{ kg/h} * (1/3600 \text{ s}) (254 \text{ kJ/kg}) * (1000 \text{ J/kJ})}{2\pi [20^\circ\text{C} - (-179.4^\circ\text{C})] \left[\frac{2(0.685)(0.61)}{0.075} + \frac{4.88}{\ln\left(\frac{0.685}{0.61}\right)} \right]} \\ k &= 0.0119 \text{ W/(m K)} \end{aligned}$$

COMMENTS

Based on data given in Appendix 2, Table 11, no common insulation has such low value of thermal conductivity. However, *Marks Standard Handbook for Mechanical Engineers* lists the thermal conductivity of expanded rubber board, 'Rubatex', at -180°C to be 0.007 W/(m K) .

PROBLEM 2.23

The addition of insulation to a cylindrical surface, such as a wire, may increase the rate of heat dissipation to the surroundings (see Problem 2.15). (a) For a No. 10 wire (0.26 cm in diameter), what is the thickness of rubber insulation [$k = 0.16 \text{ W/(m K)}$] that maximizes the rate of heat loss if the heat transfer coefficient is $10 \text{ W/(m}^2 \text{ K)}$? (b) If the current-carrying capacity of this wire is considered to be limited by the insulation temperature, what per cent increase in capacity is realized by addition of the insulation? State your assumptions.

GIVEN

- An insulated cylindrical wire
- Diameter of wire (D_w) = 0.26 cm = 0.0026 m
- Thermal conductivity of rubber (k) = 0.16 W/(m K)
- Heat transfer coefficient (\bar{h}_c) = 10 W/(m² K)

FIND

- Thickness of insulation (L_i) to maximize heat loss
- Per cent increase in current carrying capacity

ASSUMPTIONS

- The system is in steady state
- The thermal conductivity of the rubber does not vary with temperature

SKETCH

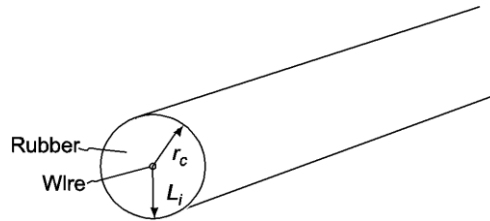

SOLUTION

- From Problem 2.15, the radius that will maximize the rate of heat transfer (r_c) is:

$$r_c = \frac{k}{h} = \frac{0.16 \text{ W/(mK)}}{10 \text{ W/(m}^2 \text{ K)}} = 0.016 \text{ m}$$

The thickness of insulation needed to make this radius is

$$L_i = r_c - r_w = 0.016 \text{ m} - \frac{0.0026 \text{ m}}{2} = 0.015 \text{ m} = 1.5 \text{ cm}$$

- The thermal circuit for the insulated wire is shown below

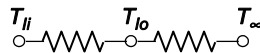

where

$$R_{kl} = \frac{\ln\left(\frac{r_o}{r_i}\right)}{2\pi Lk} \quad \text{and} \quad R_c = \frac{1}{h_c A} = \frac{1}{\bar{h}_c 2\pi r_o L}$$

The rate of heat transfer from the wire is

$$q = \frac{\Delta T}{R_{\text{total}}} = \frac{T_{li} - T_{\infty}}{R_{kl} + R_c} = \frac{2\pi L(T_{li} - T_{\infty})}{\ln\left(\frac{r_o}{r_i}\right) + \frac{1}{k} + \frac{1}{h_c r_o}}$$

If only a very thin coat of insulation is put on the wire to insulate it electrically then $r_o = r_i = D_w/2 = 0.0013$ m. The rate of heat transfer from the wire is

$$\frac{q}{L} = \frac{2\pi(T_{li} - T_{\infty})}{0 + \frac{1}{10 \text{ W}/(\text{m}^2 \text{ K})(0.0013 \text{ m})}} = 0.082 (T_{li} - T_{\infty})$$

For the wire with the critical insulation thickness

$$\frac{q}{L} = \frac{2\pi(T_{li} - T_{\infty})}{\frac{\ln\left(\frac{0.016}{0.0013}\right)}{0.16 \text{ W}/(\text{m K})} + \frac{1}{10 \text{ W}/(\text{m}^2 \text{ K})(0.016 \text{ m})}} = 0.286 (T_{li} - T_{\infty})$$

The current carrying capacity of the wire is directly related to the rate of heat transfer from the wire. For a given maximum allowable insulation temperature, the increase in current carrying capacity of the wire with the critical thickness of insulation over that of the wire with a very thin coating of insulation is

$$\begin{aligned} \% \text{ increase} &= \frac{\left(\frac{q}{L}\right)_{r_c} - \left(\frac{q}{L}\right)_{\text{thin coat}}}{\left(\frac{q}{L}\right)_{\text{thin coat}}} \times 100 = \frac{0.286 - 0.082}{0.082} \times 100 = 250\% \\ &= \end{aligned}$$

COMMENTS

This would be an enormous amount of insulation to add to the wire changing a thin wire into a rubber cable over an inch in diameter and would not be economically justifiable. Thinner coatings of rubber will achieve smaller increases in current carrying capacity.

PROBLEM 2.24

A standard 4 10 cm steel pipe ($ID = 10.066$ cm., $OD = 11.25$ cm) carries superheated steam at 650°C in an enclosed space where a fire hazard exists, limiting the outer surface temperature to 38°C . To minimize the insulation cost, two materials are to be used; first a high temperature (relatively expensive) insulation is to be applied to the pipe and then magnesia (a less expensive material) on the outside. The maximum temperature of the magnesia is to be 315°C . The following constants are known.

Steam-side coefficient	$h = 500 \text{ W}/(\text{m}^2 \text{ K})$
High-temperature insulation conductivity	$k = 0.1 \text{ W}/(\text{m K})$
Magnesia conductivity	$k = 0.076 \text{ W}/(\text{m K})$
Outside heat transfer coefficient	$h = 11 \text{ W}/(\text{m}^2 \text{ K})$
Steel conductivity	$k = 43 \text{ W}/(\text{m K})$
Ambient temperature	$T_a = 21^\circ\text{C}$

- Specify the thickness for each insulating material.
- Calculate the overall heat transfer coefficient based on the pipe OD .
- What fraction of the total resistance is due to (1) steam-side resistance, (2) steel pipe resistance, (3) insulation (combination of the two), and (4) outside resistance?
- How much heat is transferred per hour, per foot length of pipe?

GIVEN

- Steam filled steel pipe with two layers of insulation
- Pipe inside diameter (D_i) = 10.066 cm = 0.10066 m
- Pipe outside diameter (D_o) = 11.25 cm = 0.1125 m
- Superheated steam temperature (T_s) = 650°C
- Maximum outer surface temperature (T_{so}) = 38°C
- Maximum temperature of the Magnesia (T_m) = 315°C
- Thermal conductivities
 - High-temperature insulation (k_h) = $0.1 \text{ W}/(\text{m K})$
 - Magnesia (k_m) = $0.076 \text{ W}/(\text{m K})$
 - Steel (k_s) = $43 \text{ W}/(\text{m K})$
- Heat transfer coefficients
 - Steam side (\bar{h}_{ci}) = $500 \text{ W}/(\text{m}^2 \text{ K})$
 - Outside (\bar{h}_{co}) = $11 \text{ W}/(\text{m}^2 \text{ K})$
- Ambient temperature (T_a) = 21°C

FIND

- Thickness for each insulation material
- Overall heat transfer coefficient based on the pipe OD
- Fraction of the total resistance due to
 - Steam-side resistance
 - Steel pipe resistance
 - Insulation
 - Outside resistance
- The rate of heat transfer per unit length of pipe (q/L)

ASSUMPTIONS

- The system is in steady state

- Constant thermal conductivities
- Contact resistance is negligible

SKETCH

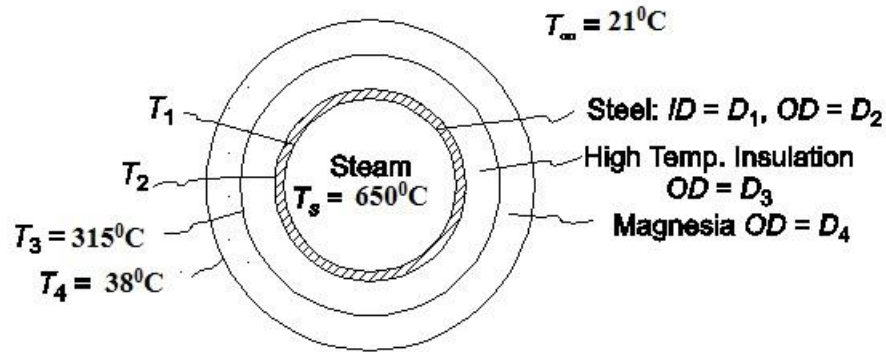

SOLUTION

The thermal circuit for the insulated pipe is shown below

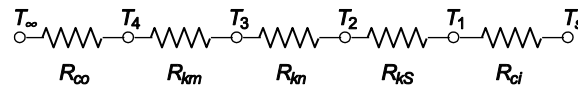

The values of the individual resistances can be evaluated with Equations (1.14) and (2.39)

$$R_{co} = \frac{1}{h_{co} A_o} = \frac{1}{h_{co} 2\pi r_4 L}$$

$$R_{km} = \frac{\ln\left(\frac{r_4}{r_3}\right)}{2\pi L k_m}$$

$$R_{kh} = \frac{\ln\left(\frac{r_3}{r_2}\right)}{2\pi L k_h}$$

$$R_{ks} = \frac{\ln\left(\frac{r_2}{r_1}\right)}{2\pi L k_s}$$

$$R_{ci} = \frac{1}{h_{ci} A_i} = \frac{1}{h_{ci} 2\pi r_1 L}$$

The variables in the above equations are

$$r_1 = 0.05033 \text{ m}$$

$$r_2 = 0.05625 \text{ m}$$

$$r_3 = ?$$

$$r_4 = ?$$

$$k_m = 0.076 \text{ W/(m K)}$$

$$k_s = 43 \text{ W/(m K)}$$

$$k_h = 0.1 \text{ W/(m K)}$$

$$\bar{h}_{co} = 11 \text{ W/(m}^2 \text{ K)}$$

$$\bar{h}_{ci} = 500 \text{ W/(m}^2 \text{ K)}$$

The temperatures for this problem are

$$T_s = 650 \text{ }^\circ\text{C}$$

$$T_1 = ?$$

$$T_2 = ?$$

$$T_3 = 315 \text{ }^\circ\text{C}$$

$$T_4 = 38 \text{ }^\circ\text{C}$$

$$T_a = 21 \text{ }^\circ\text{C}$$

There are five unknowns in this problem: q/L , T_1 , T_2 , r_3 , and r_4 . These can be solved for by writing the equation for the heat transfer through each of the five resistances and solving them simultaneously.

1. Steam side convective heat transfer

$$q = \frac{\Delta T}{R_{ci}} = 2 \pi \bar{h}_{ci} r_1 L (T_s - T_1) = 2 \pi L [500 \text{ W/(m}^2 \text{ K)}](0.05033 \text{ m}) (650 \text{ }^\circ\text{C} - T_1)$$

$$\frac{q}{L} = 102775 - 158.12 T_1 \text{ W/m} \quad [1]$$

2. Conduction through the pipe wall

$$q = \frac{\Delta T}{R_{ks}} = \frac{2 \pi k L}{\ln\left(\frac{r_2}{r_1}\right)} (T_1 - T_2) = \frac{2 \pi L [43 \text{ W/(m K)}]}{\ln\left(\frac{0.05625}{0.05033}\right)} (T_1 - T_2)$$

$$\frac{q}{L} = 2429.5 (T_1 - T_2) \text{ W/m} \quad [2]$$

3. Conduction through the high temperature insulation

$$q = \frac{\Delta T}{R_{kh}} = \frac{2 \pi k_h L}{\ln\left(\frac{r_3}{r_2}\right)} (T_2 - T_3) = \frac{2 \pi L [0.1 \text{ W/(m}^2 \text{ K)}]}{\ln(r_3) - \ln(0.05625)} (T_2 - 315 \text{ }^\circ\text{C})$$

$$\frac{q}{L} = \frac{0.628}{\ln r_3 + 2.878} (T_2 - 315) \text{ W/m} \quad [3]$$

4. Conduction through the magnesia insulation

$$q = \frac{\Delta T}{R_{km}} = \frac{2 \pi k_m L}{\ln\left(\frac{r_4}{r_3}\right)} (T_3 - T_4) = \frac{2 \pi L [0.076 \text{ W/(m}^2 \text{ K)}]}{\ln(r_4) - \ln(r_3)} (315 \text{ }^\circ\text{C} - 38 \text{ }^\circ\text{C})$$

$$\frac{q}{L} = \frac{132.3}{\ln(r_4) - \ln(r_3)} \text{ W/m} \quad [4]$$

5. Air side convective heat transfer

$$q = \frac{\Delta T}{R_{co}} = 2\pi \bar{h}_{co} r_4 L (T_4 - T_a) = 2\pi L r_4 (11 \text{ W}/(\text{m}^2 \text{ K})) (38^\circ\text{C} - 21^\circ\text{C})$$

$$\frac{q}{L} = 1174.96 r_4 \text{ W/m} \quad [5]$$

To maintain steady state, the heat transfer rate through each resistance must be equal. Equations [1] through [5] are a set of five equations with five unknowns, they may be solved through numerical iterations using a simple program or may be combined algebraically as follows

Substituting Equation [1] into Equation [2] yields

$$T_2 = 1.065 T_1 - 42.1$$

Substituting this into Equation [3] and combining the result with Equation [1]

$$\ln r_3 = \frac{0.669T_1 - 224.26}{102775 - 158.12T_1} - 2.878$$

Substituting this into Equation [4] and combining the result with Equation [1]

$$r_4 = \exp \left[\frac{0.669T_1 + 13.6}{102,775 - 158.12T_1} - 2.878 \right]$$

Finally, substituting this into Equation [5] and combining the result with Equation [1]

$$126,480 - 105.4 T_1 = 1174.96 \exp \left[\frac{0.669T_1 + 13.6}{102,775 - 158.12T_1} - 2.878 \right]$$

Solving this by trial and error: $T_1 = 648.15^\circ\text{C}$

This result can be substituted into the equations above to find the unknown radii

$$r_3 = 0.1164 \text{ m} = 11.64 \text{ cm} \quad r_4 = 0.182 \text{ m} = 18.2 \text{ cm}$$

The thickness of the high temperature insulation = $r_3 - r_2 = 6.015 \text{ cm}$

The thickness of the magnesia insulation = $r_4 - r_3 = 6.56 \text{ cm}$

(b) Substituting $T_1 = 647^\circ\text{C}$ into [1] yields a heat transfer rate of 289 W/m. The overall heat transfer coefficient based on the pipe outside area must satisfy the following equation

$$q = U A_2 (T_s - T_a) = U \pi D_2 L (T_s - T_a)$$

$$\therefore U = \frac{q}{L \pi D_2 (T_s - T_a)} = 289 \text{ W/m} \frac{1}{\pi (0.1125)(650^\circ\text{C} - 21^\circ\text{C})}$$

$$U = 1.30 \text{ W}/(\text{m}^2 \text{ K})$$

(c) The overall resistance for the insulated pipe is

$$R_{\text{total}} = \frac{1}{U A_2} = \frac{1}{[1.30 \text{ W}/(\text{m}^2 \text{ K})] \pi (0.1125) L} = \frac{1}{L} 2.18 \text{ (K/W)}$$

(1) The thermal resistance of the steam side convection is

$$R_{ci} = \frac{1}{h_{ci} A_i} = \frac{1}{h_{ci} 2\pi r_i L} = \frac{1}{(500 \text{ W}/(\text{m K})) 2\pi (0.10066) L} = \frac{1}{L} 0.0095 \text{ K/W}$$

The fraction of the resistance due to steam side convection = $0.0095/3.57 = 0.00$.

(2) The thermal resistance of the steel pipe is

$$R_{ks} = \frac{\ln\left(\frac{r_2}{r_1}\right)}{2\pi Lk_s} = \frac{\ln\left(\frac{0.05625}{0.05033}\right)}{2\pi L[43\text{W}/(\text{m K})]} = \frac{1}{L} 0.000412 \text{ K/W}$$

The fraction of the resistance due to the steel pipe = $0.000412/2.18 = 0.00015$

(3) The thermal resistance of the magnesia insulation is

$$R_{km} = \frac{\ln\left(\frac{r_4}{r_3}\right)}{2\pi Lk_m} = \frac{\ln\left(\frac{0.182}{0.1164}\right)}{2\pi L[0.076\text{W}/(\text{mK})]} = \frac{1}{L} 0.936 \text{ K/W}$$

The thermal resistance of the high temperature insulation is

$$R_{kh} = \frac{\ln\left(\frac{r_3}{r_2}\right)}{2\pi Lk_h} = \frac{\ln\left(\frac{0.1164}{0.05625}\right)}{2\pi L[0.1\text{W}/(\text{m K})]} = \frac{1}{L} 1.15 \text{ K/W}$$

The fraction of the resistance due to the insulation = $2.09/2.18 = 0.96$.

(4) The convective thermal resistance on the air side is

$$R_{co} = \frac{1}{h_{co} A_o} = \frac{1}{h_{co} 2\pi r_4 L} = \frac{1}{(11\text{W}/(\text{m K}))2\pi (0.182)L} = \frac{1}{L} 0.08 \text{ K/W}$$

The fraction of the resistance due to air side convection = $0.08/2.18 = 0.04$.

(d) The rate of heat transfer is

$$q = U A_2 (T_s - T_a) = U \pi D_2 L (T_s - T_a)$$

$$\frac{q}{L} = 1.3 \text{ W}/(\text{m}^2 \text{ K}) 2\pi (0.05625) (650^\circ\text{C} - 21^\circ\text{C}) = 288 \text{ W/m}$$

COMMENTS

Notice that the insulation accounts for 97% of the total thermal resistance and that the thermal resistance of the steel pipe and the steam side convection are negligible.

PROBLEM 2.25

Show that the rate of heat conduction per unit length through a long hollow cylinder of inner radius r_i and outer radius r_o , made of a material whose thermal conductivity varies linearly with temperature, is given by

$$\frac{q_k}{L} = \frac{T_i - T_o}{(r_o - r_i) / k_m A}$$

where T_i = temperature at the inner surface

T_o = temperature at the outer surface

$$A = 2 \pi (r_o - r_i) / \ln \frac{r_o}{r_i}$$

$$k_m = k_o [1 + \beta_k (T_i + T_o) / 2]$$

L = length of cylinder

GIVEN

- A long hollow cylinder
- The thermal conductivity varies linearly with temperature
- Inner radius = r_i
- Outer radius = r_o

FIND

- Show that the rate of heat conduction per unit length is given by the above equation

ASSUMPTIONS

- Conduction occurs in the radial direction only
- Steady state prevails

SKETCH

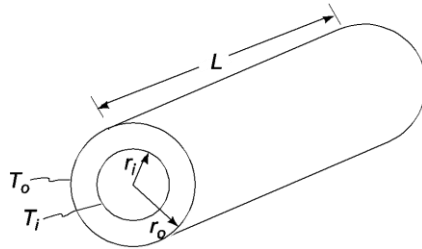

SOLUTION

The rate of radial heat transfer through a cylindrical element of radius r is

$$\frac{q}{L} = k A \frac{dT}{dr} = k 2 \pi r \frac{dT}{dr} = a \text{ constant}$$

But the thermal conductivity varies linearly with the temperature

$$k = k_o (1 + \beta T)$$

$$\therefore \frac{q}{L} = 2\pi r k_o (1 + \beta T) \frac{dT}{dr}$$

$$\frac{q}{L} \frac{1}{1 + \beta T} = 2\pi k_o r dT$$

$$L \int_r dr = 2\pi k_o (1 + \beta T) dT$$

Integrating between the inner and outer radii

$$\frac{q}{L} \int_{r_i}^{r_o} \frac{1}{r} dr = 2\pi k_o \int_{T_i}^{T_o} (1 + \beta T) dt$$

$$\frac{q}{L} (\ln r_o - \ln r_i) = 2\pi k_o \left[T_o + \frac{\beta}{2} T_o^2 - T_i - \frac{\beta}{2} T_i^2 \right]$$

$$\frac{q}{L} \left(\ln \frac{r_o}{r_i} \right) = 2\pi k_o \left[(T_o - T_i) + \frac{\beta}{2} (T_o^2 - T_i^2) \right]$$

$$\frac{q}{L} = \left[\frac{2\pi(r_o - r_i)}{\ln \frac{r_o}{r_i} (r_o - r_i)} \right] k_o (T_o - T_i) \left[1 + \frac{\beta}{2} (T_o + T_i) \right]$$

$$\frac{q}{L} = \frac{\bar{A}}{(r_o - r_i)} k_m (T_o - T_i)$$

$$\frac{q}{L} = \frac{T_o - T_i}{\left(\frac{r_o - r_i}{k_m \bar{A}} \right)}$$

where $\bar{A} = 2\pi (r_o - r_i) / \ln \frac{r_o}{r_i}$

$$k_m = k_o [1 + \beta_k (T_i + T_o)/2]$$

PROBLEM 2.26

A long, hollow cylinder is constructed from a material whose thermal conductivity is a function of temperature according to $k = 0.15 + 0.0018 T$, where T is in C and k is in W/(m K). The inner and outer radii of the cylinder are 12.5 and 25 cm, respectively. Under steady-state conditions, the temperature at the interior surface of the cylinder is 427°C and the temperature at the exterior surface is 93°C .

- (a) Calculate the rate of heat transfer per meter length, taking into account the variation in thermal conductivity with temperature. (b) If the heat transfer coefficient on the exterior surface of the cylinder is $17 \text{ W}/(\text{m}^2 \text{ K})$, calculate the temperature of the air on the outside of the cylinder.

GIVEN

- A long hollow cylinder
- Thermal conductivity (k) = $0.15 + 0.0018 T$ [T in $^\circ\text{C}$, k in $\text{W}/(\text{m K})$]
- Inner radius (r_i) = 12.5 cm
- Outer radius (r_o) = 25 cm
- Interior surface temperature (T_{wi}) = 427°C
- Exterior surface temperature (T_{wo}) = 93°C
- Exterior heat transfer coefficient (\bar{h}_o) = $17 \text{ W}/(\text{m}^2 \text{ K})$
- Steady-state conditions

FIND

- (a) The rate of heat transfer per meter length (q/L)
(b) The temperature of the air on the outside (T_∞)

ASSUMPTIONS

- Steady state heat transfer
- Conduction occurs in the radial direction only

SKETCH

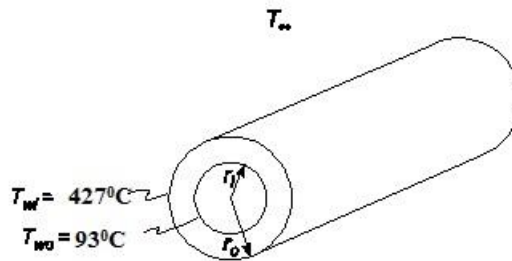

SOLUTION

- (a) The rate of radial conduction is given by Equation (2.37)

$$q = -k A \frac{dT}{dr}$$

$$q = -(0.15 + 0.0018 T) 2\pi r L \frac{dT}{dr}$$

$$\frac{1}{r} dr = -\frac{2\pi L}{q} (0.15 + 0.0018 T) dT$$

Integrating this from the inside radius to the outside radius

$$\int_{r_i}^{r_o} \frac{1}{r} dr = -\frac{2\pi L}{q} \int_{T_{wi}}^{T_{wo}} (0.15 + 0.0018 T) dT$$

$$\ln r_o - \ln r_i = -\frac{2\pi L}{q} [0.15 (T_{wo} - T_{wi}) + 0.0009 (T_{wo}^2 - T_{wi}^2)]$$

$$\ln \frac{r_o}{r_i} = 2\pi \frac{L}{q} [0.15 (T_{wo} - T_{wi}) + 0.0009 (T_{wo}^2 - T_{wi}^2)]$$

$$\frac{q}{L} = \frac{2\pi}{\ln\left(\frac{r_o}{r_i}\right)} [0.15 (T_{wo} - T_{wi}) + 0.0009 (T_{wo}^2 - T_{wi}^2)]$$

$$\frac{q}{L} = \frac{2\pi}{\ln\left(\frac{25}{12.5}\right)} [0.15 (427 - 93) + 0.0009 (427^2 - 93^2)] \text{ W/m}$$

$$\frac{q}{L} = 1871.1 \text{ W/m}$$

(b) The conduction through the hollow cylinder must equal the convection from the outer surface in steady state

$$\frac{q}{L} = \bar{h}_o A_o \Delta T = \bar{h}_o 2\pi r_o (T_{wo} - T_\infty)$$

Solving for the air temperature

$$T_\infty = T_{wo} - \frac{q}{L} \frac{1}{\bar{h}_o 2\pi r_o} = 93^\circ\text{C} - 1871.1 \text{ W/m} * \frac{1}{17 \text{ W}/(\text{m}^2 \text{ K}) * 2\pi (0.25\text{m})} = 23^\circ\text{C}$$

PROBLEM 2.27

Derive an expression for the temperature distribution in an infinitely long rod of uniform cross section within which there is uniform heat generation at the rate of 1 W/m. Assume that the rod is attached to a surface at T_s and is exposed through a convective heat transfer coefficient h to a fluid at T_f .

GIVEN

- An infinitely long rod with internal heat generation
- Temperature at one end = T_s
- Heat generation rate ($\dot{q}_G A$) = 1 W/m
- Convective heat transfer coefficient = h_c
- Ambient fluid temperature = T_f

FIND

- Expression for the temperature distribution

ASSUMPTIONS

- The rod is in steady state
- The thermal conductivity (k) is constant

SKETCH

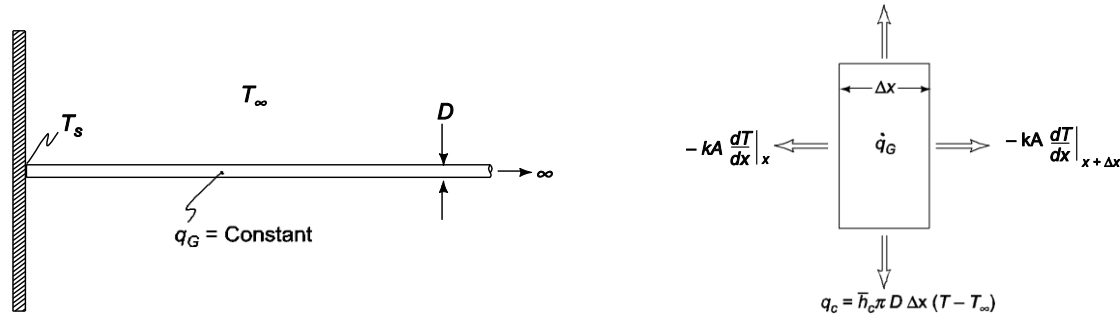

SOLUTION

Let A = the cross sectional area of the rod = $\pi D^2/4$

An element of the rod with heat flows is shown at the right

Conservation of energy requires that

Energy entering the element + Heat generation = Energy leaving the element

$$-k A \left. \frac{dT}{dx} \right|_x + \dot{q}_G A \Delta x = -k A \left. \frac{dT}{dx} \right|_{x+\Delta x} + \bar{h}_c \pi D \Delta x [T(x) - T_f]$$

$$kA \left(\left. \frac{dT}{dx} \right|_{x+\Delta x} - \left. \frac{dT}{dx} \right|_x \right) = \bar{h}_c \pi D \Delta x (T - T_f) - \dot{q}_G A \Delta x$$

Dividing by Δx and letting $\Delta x \rightarrow 0$ yields

$$kA \frac{d^2 T}{dx^2} = \bar{h}_c \pi D (T - T_f) - \dot{q}_G A$$

$$\frac{d^2 T}{dx^2} = \frac{4\bar{h}_c}{Dk} (T - T_f) - \frac{\dot{q}_G}{k}$$

Let $\theta = T - T_f$ and $m^2 = \frac{4h_c}{(Dk)}$

$$\frac{d^2 \theta}{dx^2} - m^2 \theta = \frac{-\dot{q}_G}{k}$$

This is a second order, linear, nonhomogeneous differential equation with constant coefficients. Its solution is the addition of the homogeneous solution and a particular solution. The solution to the homogeneous equation

$$\frac{d^2 \theta}{dx^2} - m^2 \theta = 0$$

is determined by its characteristic equation. Substituting $\theta = e^{\lambda x}$ and its derivatives into the homogeneous equation yields the characteristic equation

$$\lambda^2 e^{\lambda x} - m^2 e^{\lambda x} = 0 \Rightarrow \lambda = \pm m$$

Therefore, the homogeneous solution has the form

$$\theta_h = C_1 e^{mx} + C_2 e^{-mx}$$

A particular solution for this problem is simply a constant

$$\theta = a_o$$

Substituting this into the differential equation

$$0 - m^2 a_o = \frac{-\dot{q}_G}{k} \Rightarrow a_o = \frac{\dot{q}_G}{m^2 k}$$

Therefore, the general solution is

$$q = C_1 e^{mx} + C_2 e^{-mx} + \frac{\dot{q}_G}{m^2 k}$$

With the boundary conditions

$$\theta = a \text{ finite number as } x \rightarrow \infty$$

$$\theta = T_s - T_f \text{ at } x = 0$$

From the first boundary condition, as $x \rightarrow \infty e^{mx} \rightarrow \infty$, therefore $C_1 = 0$

From the second boundary condition

$$T_s - T_f = C_2 + \frac{\dot{q}_G}{m^2 k} \Rightarrow C_2 = T_s - T_f - \frac{\dot{q}_G}{m^2 k}$$

The temperature distribution in the rod is

$$q = T(x) - T_f = \left(T_s - T_f - \frac{\dot{q}_G}{m^2 k} \right) e^{-mx} + \frac{\dot{q}_G}{m^2 k}$$

$$T(x) = T_f + \left(T_s - T_f - \frac{\dot{q}_G}{m^2 k} \right) e^{-mx} + \frac{\dot{q}_G}{m^2 k}$$

PROBLEM 2.28

Heat is generated uniformly in the fuel rod of a nuclear reactor. The rod has a long, hollow cylindrical shape with its inner and outer surfaces at temperatures of T_i and T_o , respectively. Derive an expression for the temperature distribution.

GIVEN

- A long, hollow cylinder with uniform internal generation
- Inner surface temperature = T_i
- Outer surface temperature = T_o

FIND

- The temperature distribution

ASSUMPTIONS

- Conduction occurs only in the radial direction
- Steady state prevails

SKETCH

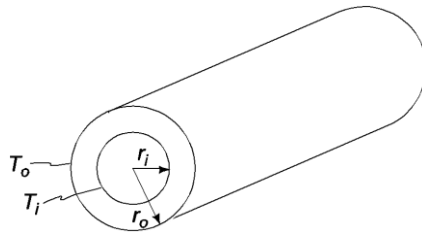

SOLUTION

Let

r_i = the inner radius

r_o = the outer radius

\dot{q}_G = the rate of internal heat generation per unit volume

k = the thermal conductivity of the fuel rod

The one dimensional, steady state conduction equation in cylindrical coordinates is given in Equation (2.21)

$$\frac{1}{r} \frac{d}{dr} \left(r \frac{dT}{dr} \right) + \frac{\dot{q}_G}{k} = 0$$

$$\frac{d}{dr} \left(r \frac{dT}{dr} \right) = \frac{-r \dot{q}_G}{k}$$

With boundary conditions

$$T = T_i \text{ at } r = r_i$$

$$T = T_o \text{ at } r = r_o$$

Integrating the conduction equation once

$$r \frac{dT}{dr} = \frac{-r^2 \dot{q}_G}{2k} + C_1$$

$$dT = \left(\frac{-r^2 \dot{q}_G}{2k} + \frac{C_1}{r} \right) dr$$

Integrating again

$$T = \frac{-r^2 \dot{q}_G}{4k} + C_1 \ln(r) + C_2$$

Applying the first boundary condition

$$T_i = \frac{-r_i^2 \dot{q}_G}{4k} + C_1 \ln(r_i) + C_2$$

$$C_2 = T_i + \frac{r_i^2 \dot{q}_G}{4k} - C_1 \ln(r_i)$$

Applying the second boundary condition

$$T_o = \frac{-r_o^2 \dot{q}_G}{4k} + C_1 \ln(r_o) + C_2$$

$$T_o = \frac{-r_o^2 \dot{q}_G}{4k} + C_1 \ln(r_o) + T_i + \frac{r_i^2 \dot{q}_G}{4k} - C_1 \ln(r_i)$$

$$C_1 = \frac{T_o - T_i + \frac{\dot{q}_G}{4k}(r_o^2 - r_i^2)}{\ln\left(\frac{r_o}{r_i}\right)}$$

Substituting the constants into the temperature distribution

$$T = \frac{-r^2 \dot{q}_G}{4k} + \left(\frac{T_o - T_i + \frac{\dot{q}_G}{4k}(r_o^2 - r_i^2)}{\ln\left(\frac{r_o}{r_i}\right)} \right) \ln(r) + T_i + \frac{r_i^2 \dot{q}_G}{4k} - \left(\frac{T_o - T_i + \frac{\dot{q}_G}{4k}(r_o^2 - r_i^2)}{\ln\left(\frac{r_o}{r_i}\right)} \right) \ln\left(\frac{r_i}{r_i}\right)$$

$$T = \frac{\dot{q}_G}{4k} \left(\frac{-r^2}{\ln\left(\frac{r_o}{r_i}\right)} + (r_i^2 - r^2) \right) + \frac{(T_o - T_i) \ln\left(\frac{r}{r_i}\right)}{\ln\left(\frac{r_o}{r_i}\right)} + T_i$$

PROBLEM 2.29

In a cylindrical fuel rod of a nuclear reactor, heat is generated internally according to the equation

$$\dot{q}_G = \dot{q}_1 \left[1 - \left(\frac{r}{r_o} \right)^2 \right]$$

where \dot{q}_g = local rate of heat generation per unit volume at r

r_o = outside radius

\dot{q}_1 = rate of heat generation per unit volume at the centerline

Calculate the temperature drop from the center line to the surface for a 2.5 cm diameter rod having a thermal conductivity of 26 W/(m K) if the rate of heat removal from its surface is 1.6 MW/m².

GIVEN

- A cylindrical rod with internal generation and heat removal from its surface
- Outside diameter (D_o) = 2.5 cm = 0.025 m
- Rate of heat generation is as given above
- Thermal conductivity (k) = 26 W/(m K)
- Heat removal rate (q/A) = 1.6 MW/m²

FIND

- The temperature drop from the center line to the surface (ΔT)

ASSUMPTIONS

- The heat flow has reached steady state
- The thermal conductivity of the fuel rod is constant
- One dimensional conduction in the radial direction

SKETCH

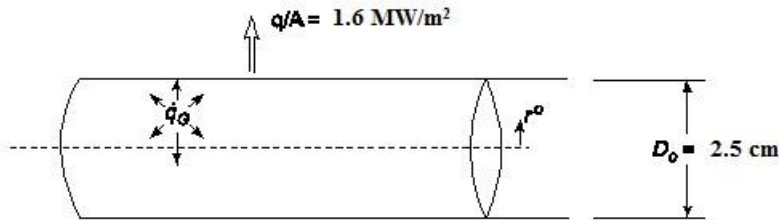

SOLUTION

The equation for one dimensional conduction in cylindrical coordinates is given in Equation (2.21)

$$\frac{1}{r} \frac{d}{dr} \left(r \frac{dT}{dr} \right) + \frac{\dot{q}_G}{k} = 0$$

$$\frac{d}{dr} \left(r \frac{dT}{dr} \right) = \frac{-r}{k} \dot{q}_1 \left[1 - \left(\frac{r}{r_o} \right)^2 \right]$$

With the boundary conditions

$$\frac{dT}{dr} = 0 \text{ at } r = 0$$

$$T = T_s \text{ at } r = r_o$$

Integrating once

$$r \frac{dT}{dr} = \frac{-r^2 q_1}{2k} + \frac{r^4 q_1}{4k r_o^2} + C_1$$

From the first boundary condition: $C_1 = 0$, therefore

$$\frac{dT}{dr} = \frac{q_1}{2k} \left(\frac{r^3}{2r_o^2} - r \right)$$

Integrating again

$$T = \frac{q_1}{2k} \left(\frac{r^4}{8r_o^2} - \frac{r^2}{2} \right) + C_2$$

Evaluate this expression at the surface of the cylinder and at the centerline of the sphere and subtracting the results gives us the temperature drop in the cylinder

$$\Delta T = T_0 - T_{r_o} = \frac{q_1}{2k} \left(\frac{(0)^4}{8r_o^2} - \frac{(0)^2}{2} - \frac{r_o^4}{8r_o^2} + \frac{r_o^2}{2} \right) = \frac{3q_1 r_o^2}{16k}$$

The rate of heat generation at the centerline (q_1) can be evaluated using the conservation of energy. The total rate of heat transfer from the cylinder must equal the total rate of heat generation within the cylinder

$$\left(\frac{q}{A} \right) A = L \int_{r=0}^{r=r_o} q_1 \left[1 - \frac{r^4}{r_o^2} \right] 2\pi r dr$$

$$\left(\frac{q}{A} \right) 2\pi r_o L = 2\pi L q_1 \left[\frac{r^2}{2} - \frac{r^4}{4r_o^2} \right]_0^{r_o}$$

$$\left(\frac{q}{A} \right) r_o = q_1 \left[\frac{r_o^2}{2} - \frac{r_o^2}{4} \right] = q_1 \frac{r_o^2}{4}$$

$$\therefore q_1 = \frac{4}{r_o} \left(\frac{q}{A} \right) = \frac{4}{0.0125m} [1.6 \times 10^6 \text{ W/m}^2] = 5.12 \times 10^8 \text{ W/m}^2$$

Therefore, the temperature drop within the cylinder is

$$\Delta T = \frac{3[5.12 \times 10^8 \text{ W/m}^2](0.0125)^2}{16[26 \text{ W/(mK)}]} = 577^\circ\text{C}$$

PROBLEM 2.30

An electrical heater capable of generating 10,000 W is to be designed. The heating element is to be a stainless steel wire, having an electrical resistivity of 80×10^{-6} ohm-centimeter. The operating temperature of the stainless steel is to be no more than 1260°C. The heat transfer coefficient at the outer surface is expected to be no less than 1720 W/(m² K) in a medium whose maximum temperature is 93°C. A transformer capable of delivering current at 9 and 12 V is available. Determine a suitable size for the wire, the current required, and discuss what effect a reduction in the heat transfer coefficient would have. (Hint: Demonstrate first that the temperature drop between the center and the surface of the wire is independent of the wire diameter, and determine its value.)

GIVEN

- A stainless steel wire with electrical heat generation
- Heat generation rate (\dot{Q}_G) = 10,000 W
- Electrical resistivity (ρ) = 80×10^{-6} ohms-cm
- Maximum temperature of stainless steel (T_{\max}) = 1260°C
- Heat transfer coefficient (\bar{h}_c) = 1700 W/(m² K)
- Maximum temperature of medium (T_∞) = 93°C
- Voltage (V) = 9 or 12 V

FIND

- (a) A suitable wire size: diameter (d_w) and length (L)
- (b) The current required (I)
- (c) Discuss the effect of reduction in the heat transfer coefficient

ASSUMPTIONS

- Variation in the thermal conductivity of stainless steel is negligible
- The system is in steady-state
- Conduction occurs in the radial direction only

SKETCH

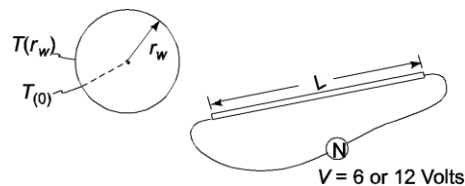

PROPERTIES AND CONSTANTS

From Appendix 2, Table 10, Thermal conductivity of stainless steel (k) = 14.4 W/(m² K)

SOLUTION

The rate of heat generation per unit volume is

$$\dot{q}_G = \frac{\dot{Q}_G}{\text{volume}} = \frac{\dot{Q}_G}{\pi r_w^2 L}$$

The temperature distribution in a long cylinder with internal heat generation is given in Section 2.3.3

$$T(r) = C_2 - \frac{\dot{q}_G r^2}{4k}$$

where C_2 is a constant determined by boundary conditions. Therefore

$$T(0) - T(r_w) = [C_2 - 0] - \left[C_2 - \frac{\dot{q}_G r_w^2}{4k} \right] = \frac{\dot{q}_G r_w^2}{4k} = \frac{\dot{Q}_G}{4\pi kL}$$

The convective heat transfer from the outer surface must equal the internal heat generation

$$q_c = \bar{h}_c A [T(r_w) - T_\infty] = \dot{Q}_G$$

$$\therefore T(r_w) - T_\infty = \frac{\dot{Q}_G}{2\pi r_w L \bar{h}_c}$$

Adding the two temperature differences calculated above yields

$$[T(0) - T(r_w)] + [T(r_w) - T_\infty] = \frac{\dot{Q}_G}{4\pi kL} + \frac{\dot{Q}_G}{2\pi r_w L \bar{h}_c}$$

$$T(0) - T_\infty = \frac{\dot{Q}_G}{2\pi} \left(\frac{1}{2kL} + \frac{1}{r_w L \bar{h}_c} \right)$$

The wire length and its radius are related through an expression for the electric power dissipation

$$\dot{Q}_G = P_e = \frac{V^2}{R_e} = \frac{V^2}{\rho L} = \frac{V^2 \pi r_w^2}{\rho L} \Rightarrow L = \frac{\pi V^2 \pi r_w^2}{\rho \dot{Q}_G}$$

$$\therefore T(0) - T_\infty = \frac{\dot{Q}_G^2 \rho}{2\pi^2 V^2} \left(\frac{1}{2k r_w^2} + \frac{1}{r_w^3 \bar{h}_c} \right)$$

$$r_w^2 [T(0) - T_\infty] - \frac{2\dot{Q}_G^2 V^2}{\pi} \left(\frac{1}{2k} + \frac{1}{\bar{h}_c} \right) = 0$$

For the 12 volt case

$$r_w^3 (1260^\circ\text{C} - 90^\circ\text{C}) - \frac{(10,000\text{W})^2 (80 \times 10^{-6} \text{ ohm-cm})}{2\pi^2 (12\text{V})^2 (100\text{cm/m})} \left(\frac{r_w}{2 \cdot 14.4 \text{ W/(mK)}} + \frac{1}{1700 \text{ (W/(m}^2\text{K))}} \right) = 0$$

After checking the units, they are dropped for clarity

$$1167 r_w^3 - 0.0281(0.0347 r^2 + 0.000581) = 0$$

Solving by trial and error

$$r_w = 0.0025 \text{ m} = 2.5 \text{ mm}$$

For the 12 volt case, the suitable wire diameter is

$$d_w = 2(r_w) = 5 \text{ mm}$$

The length of the wire required is

$$L = \frac{\pi(12 \text{ V})^2 (0.0025 \text{ m})^2 - (100 \text{ cm/m})}{80 \times 10^{-6} \text{ ohm-cm}(10,000 \text{ W})} = 0.353 \text{ m}$$

The electrical resistance of this wire is

$$R_e = \frac{\rho L}{\pi r_w^2} = \frac{80 \times 10^{-6} \text{ ohm-cm}(0.353 \text{ m})}{\pi (0.0025 \text{ m})^2 * (100 \text{ cm/m})} = 0.0144 \text{ ohm}$$

Therefore, the current required for the 12 volt case is

$$I = \frac{V}{R_e} = \frac{12\text{V}}{0.0144\text{ohm}} = 833 \text{ amps}$$

This same procedure can be used for the 9 volt case yielding

$$d_w = 6.3 \text{ mm}$$

$$L = 0.306 \text{ m}$$

$$R_e = 0.0081 \text{ ohm}$$

$$I = 1111 \text{ amps}$$

COMMENTS

The 5-mm-diameter wire would be a better choice since the amperage is less. However, 833 amps is still extremely high.

The effect of a lower heat transfer coefficient would be an increase in the diameter and length of the wire as well as an increase in the surface temperature of the wire.

STEADY STATE CONDUCTION IN SPHERE

PROBLEM 2.31

A hollow sphere with inner and outer radii of R_1 and R_2 , respectively, is covered with a layer of insulation having an outer radius of R_3 . Derive an expression for the rate of heat transfer through the insulated sphere in terms of the radii, the thermal conductivities, the heat transfer coefficients, and the temperatures of the interior and the surrounding medium of the sphere.

GIVEN

- An insulated hollow sphere
- Radii
 - Inner surface of the sphere = R_1
 - Outer surface of the sphere = R_2
 - Outer surface of the insulation = R_3

FIND

- Expression for the rate of heat transfer

ASSUMPTIONS

- Steady state heat transfer
- Conduction in the radial direction only
- Constant thermal conductivities

SKETCH

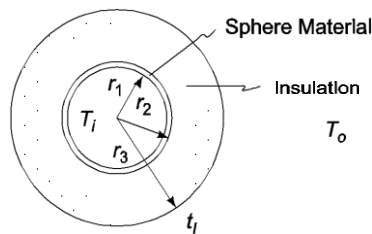

SOLUTION

Let k_{12} = the thermal conductivity of the sphere
 k_{23} = the thermal conductivity of the insulation
 h_1 = the interior heat transfer coefficient
 h_3 = the exterior heat transfer coefficient
 T_i = the temperature of the interior medium
 T_o = the temperature of the exterior medium

The thermal circuit for the sphere is shown below

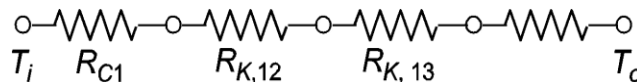

The individual resistances are

$$R_{c1} = \frac{-1}{h_1 A_1} = \frac{1}{\bar{h}_1 4\pi R_1^2 L}$$

From Equation (2.51)

$$R_{k12} = \frac{R_2 - R_1}{4\pi k_{12} R_2 R_1}$$

$$R_{k23} = \frac{R_3 - R_2}{4\pi k_{23} R_3 R_2}$$

$$R_{c3} = \frac{1}{h_3 A_3} = \frac{1}{h_3 4\pi R_3^2 L}$$

The rate of heat transfer is

$$q = \frac{\Delta T}{R_{\text{total}}} = \frac{\Delta T}{R_{c1} + R_{k12} + R_{k23} + R_{c3}}$$

$$q = \frac{T}{\Delta} \frac{1}{4\pi \left(\frac{1}{R_1^2 h_1} + \frac{R_2 - R_1}{k_{12} R_2 R_1} + \frac{R_3 - R_2}{k_{23} R_3 R_2} + \frac{1}{R_3 h_3} \right)}$$

$$q = \frac{4\pi \Delta T}{\frac{1}{R_1^2 h_1} + \frac{R_2 - R_1}{k_{12} R_2 R_1} + \frac{R_3 - R_2}{k_{23} R_3 R_2} + \frac{1}{R_3 h_3}}$$

PROBLEM 2.32

The thermal conductivity of a material can be determined in the following manner. Saturated steam $2.41 \times 10^5 \text{ N/m}^2$ is condensed at the rate of 0.68 kg/h inside a hollow iron sphere that is 1.3 cm thick and has an internal diameter of 51 cm . The sphere is coated with the material whose thermal conductivity is to be evaluated. The thickness of the material to be tested is 10 cm and there are two thermocouples embedded in it, one 1.3 cm from the surface of the iron sphere and one 1.3 cm from the exterior surface of the system. If the inner thermocouple indicates a temperature of 110°C and the outer thermocouple a temperature of 57°C , calculate (a) the thermal conductivity of the material surrounding the metal sphere, (b) the temperatures at the interior and exterior surfaces of the test material, and (c) the overall heat transfer coefficient based on the interior surface of the iron sphere, assuming the thermal resistances at the surfaces, as well as the interface between the two spherical shells, are negligible.

GIVEN

- Hollow iron sphere with saturated steam inside and coated with material outside
- Steam pressure = $2.41 \times 10^5 \text{ N/m}^2$
- Steam condensation rate (\dot{m}_s) = 0.68 kg/h
- Inside diameter (D_i) = $51 \text{ cm} = 0.51 \text{ m}$
- Thickness of the iron sphere (L_s) = $1.3 \text{ cm} = 0.013 \text{ m}$
- Thickness of material layer (L_m) = $10 \text{ cm} = 0.1 \text{ m}$
- Two thermocouples are located 1.3 cm from the inner and outer surface of the material layer
- Inner thermocouple temperature (T_1) = 110°C
- Outer thermocouple temperature (T_2) = 57°C

FIND

- Thermal conductivity of the material (k_m)
- Temperatures at the interior and exterior surfaces of the test material (T_{mi} , T_{mo})
- Overall heat transfer coefficient based on the inside area of the iron sphere (U)

ASSUMPTIONS

- Thermal resistance at the surface is negligible
- Thermal resistance at the interface is negligible
- The system has reached steady-state
- The thermal conductivities are constant
- One dimensional conduction radially

SKETCH

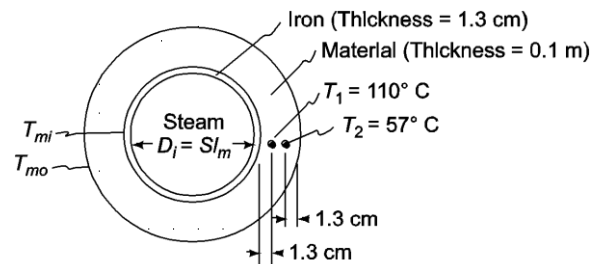

PROPERTIES AND CONSTANTS

From Appendix 2, Table 13: For saturated steam at $2.41 \times 10^5 \text{ N/m}^2$,
Saturation temperature (T_s) = 125°C

Heat of vaporization (h_{fg}) = 2187 kJ/kg

SOLUTION

(a) The rate of heat transfer through the sphere must equal the energy released by the condensing steam:

$$q = \dot{m}_s h_{fg} = 0.68 \text{ kg/h} \cdot 2187 \text{ kJ/kg} \cdot 1000 \text{ J/kJ} \left(\frac{\text{h}}{3600\text{s}} \right) (\text{Ws})/\text{J} = 413.1 \text{ W}$$

The thermal conductivity of the material can be calculated by examining the heat transfer between the thermocouple radii

$$q = \frac{\Delta T}{R_{k12}} = \frac{T_2 - T_1}{\left(\frac{r_2 - r_1}{4\pi k_m r_2 r_1} \right)}$$

Solving for the thermal conductivity

$$k_m = \frac{q(r_2 - r_1)}{4\pi r_2 r_1 (T_2 - T_1)}$$

$$r_1 = \frac{D_i}{2} + L_s + 0.013 \text{ m} = \frac{0.51 \text{ m}}{2} + 0.013 \text{ m} + 0.013 \text{ m} = 0.281 \text{ m}$$

$$r_2 = \frac{D_i}{2} + L_s + L_m - 0.013 \text{ m} = \frac{0.51 \text{ m}}{2} + 0.013 \text{ m} + 0.1 \text{ m} - 0.013 \text{ m} = 0.355$$

$$k_m = \frac{413.1 \text{ W}(0.355 \text{ m} - 0.281 \text{ m})}{4\pi (0.355 \text{ m})(0.281 \text{ m})(110^\circ\text{C} - 57^\circ\text{C})} = 0.46 \text{ W}/(\text{m K})$$

(b) The temperature at the inside of the material can be calculated from the equation for conduction through the material from the inner radius, the radius of the inside thermocouple

$$q = \frac{\Delta T}{R_{ki1}} = \frac{T_{mi} - T_i}{\left(\frac{r_1 - r_i}{4\pi k_m r_1 r_i} \right)}$$

Solving for the temperature of the inside of the material

$$T_{mi} = T_1 + \frac{q(r_1 - r_i)}{4\pi k_m r_1 r_i}$$

$$r_i = \frac{D_i}{2} + L_m = \frac{0.51 \text{ m}}{2} + 0.013 \text{ m} = 0.268 \text{ m}$$

$$T_{mi} = 110^\circ\text{C} + \frac{413.1 \text{ W}(0.013 \text{ m})}{4\pi [0.46 \text{ W}/(\text{mK})](0.281 \text{ m})(0.268 \text{ m})} = 122^\circ\text{C}$$

The temperature at the outside radius of the material can be calculated from the equation for conduction through the material from the radius of the outer thermocouple to the outer radius

$$q = \frac{\Delta T}{R_{k2o}} = \frac{T_2 - T_{mo}}{\left(\frac{r_o - r_2}{4\pi k_m r_o r_2} \right)}$$

Solving for the temperature of the outer surface of the material

$$T_{mo} = T_2 - \frac{q(r_o - r_2)}{4\pi k_m r_o r_2}$$

$$r_o = \frac{D_i}{2} + L_s + L_m = \frac{0.51 \text{ m}}{2} + 0.013 \text{ m} + 0.01 \text{ m} = 0.368 \text{ m}$$

$$T_{mo} = 57^\circ\text{C} - \frac{413.1 \text{ W} (0.013 \text{ m})}{4\pi [0.46 \text{ W}/(\text{mK})] (0.368 \text{ m}) (0.355 \text{ m})} = 50^\circ\text{C}$$

(c) The heat transfer through the sphere can be expressed as

$$q = U A_i \Delta T = U \pi D_i^2 (T_s - T_{mo})$$

$$\therefore U = \frac{q}{\pi D_i^2 (T_s - T_{mo})} = \frac{413.1 \text{ W}}{\pi (0.51 \text{ m})^2 (125^\circ\text{C} - 50^\circ\text{C})} = 6.74 \text{ W}/(\text{m}^2 \text{ K})$$

PROBLEM 2.33

For the system outlined in Problem 2.31, determine an expression for the critical radius of the insulation in terms of the thermal conductivity of the insulation and the surface coefficient between the exterior surface of the insulation and the surrounding fluid. Assume that the temperature difference, R_1 , R_2 , the heat transfer coefficient on the interior, and the thermal conductivity of the material of the sphere between R_1 and R_2 are constant.

GIVEN

- An insulated hollow sphere
- Radii
 - Inner surface of the sphere = R_1
 - Outer surface of the sphere = R_2
 - Outer surface of the insulation = R_3

FIND

- An expression for the critical radius of the insulation

ASSUMPTIONS

- Constant temperature difference, radii, heat transfer coefficients, and thermal conductivities
- Steady state prevails

SKETCH

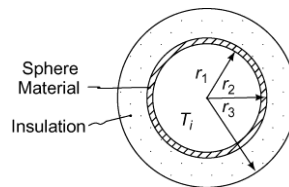

SOLUTION

Let

k_{12} = the thermal conductivity of the sphere
 k_{23} = the thermal conductivity of the insulation
 h_1 = the interior heat transfer coefficient
 h_3 = the exterior heat transfer coefficient
 T_i = the temperature of the interior medium
 T_o = the temperature of the exterior medium

From Problem 2.11, the rate of heat transfer through the sphere is

$$q = \frac{4\pi \Delta T}{\frac{1}{R_1^2 h_1} + \frac{R_2 - R_1}{k_{12} R_2 R_1} + \frac{R_3 - R_2}{k_{23} R_3 R_2} + \frac{1}{R_3^2 h_3}}$$

The rate of heat transfer is a maximum when the denominator of the above equation is a minimum. This occurs when the derivative of the denominator with respect to R_3 is zero

$$\frac{d}{dR_3} \left(\frac{1}{R_1^2 h_1} + \frac{R_2 - R_1}{k_{12} R_2 R_1} + \frac{R_3 - R_2}{k_{23} R_3 R_2} + \frac{1}{R_3^2 h_3} \right) = 0 \Rightarrow -\frac{2}{h_3 R_3} + \frac{1}{k_{23}} = 0$$

$$R_3 = 2k_{23}/h_3$$

The maximum heat transfer will occur when the outer insulation radius is equal to $2k_{23}/h_3$.

PROBLEM 2.34

Show that the temperature distribution in a sphere of radius r_o , made of a homogeneous material in which energy is released at a uniform rate per unit volume \dot{q}_G , is

$$T(r) = T_o + \frac{\dot{q}_G r_o^2}{6k} \left[1 - \left(\frac{r}{r_o} \right)^2 \right]$$

GIVEN

- A homogeneous sphere with energy generation
- Radius = r_o

FIND

- Show that the temperature distribution is as shown above.

ASSUMPTIONS

- Steady state conditions persist
- The thermal conductivity of the sphere material is constant
- Conduction occurs in the radial direction only

SKETCH

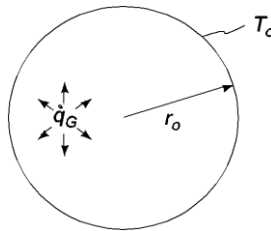

SOLUTION

Let k = the thermal conductivity of the material

T_o = the surface temperature of the sphere

Equation (2.23) can be simplified to the following equation by the assumptions of steady state and radial conduction only

$$\frac{1}{r^2} \frac{d}{dr} \left(r^2 \frac{dT}{dr} \right) + \frac{\dot{q}_G}{k} = 0$$

$$\frac{d}{dr} \left(r^2 \frac{dT}{dr} \right) = \frac{-r^2 \dot{q}_G}{k}$$

With the following boundary conditions

$$\frac{dT}{dr} = 0 \text{ at } r = 0$$

$$T = T_o \text{ at } r = r_o$$

Integrating the differential equation once

$$r^2 \frac{dT}{dr} = \frac{-r^3 q_G}{3k} + C_1$$

From the first boundary condition

$$C_1 = 0$$

Integrating once again

$$T = \frac{-r^2 q_G}{6k} + C_2$$

Applying the second boundary condition

$$T_o = \frac{-r_o^2 q_G}{6k} + C_2 \Rightarrow C_2 = T_o + \frac{-r_o^2 q_G}{6k}$$

Therefore, the temperature distribution in the sphere is

$$T = \frac{-r^2 q_G}{6k} + T_o + \frac{-r_o^2 q_G}{6k}$$

$$T(r) = T_o + \frac{q_G r_o^2}{6k} \left[1 - \left(\frac{r}{r_o} \right)^2 \right]$$

PROBLEM 2.35

Liquid oxygen is to be stored on a service module of NASA's new Orion Spacecraft (NASA, "Orion Quick Facts," FS-2014-08-004-JSC, Lyndon B. Johnson Space Center, Houston, TX) in a spherical stainless steel container. The service module is depicted in the figure below (note the various spherical containers shown), and the entire Orion Spacecraft is shown later in figure. 3.1(Chapter 3). The container has an outside diameter of 1.0 m and a wall thickness of 10 mm. The boiling point of liquid oxygen is 90 K, and its latent heat is 213 kJ/Kg. The tank is to be installed in an environment where loss of oxygen from the container is not to exceed 1.0 kg/day. Tank is to be installed in service module where ambient temperature is 225 K and convection coefficient is 5 W/ (m² K). To ensure this calculate the thermal conductivity of material used for insulation if its thickness is 10 cm.

GIVEN

- Liquid oxygen container with 1.0 m diameter and 10 mm thickness.
- Boiling point of oxygen (T_b)= 90 K
- Ambient temperature (T_∞)=225 K
- Convection coefficient (h)= 5 W/ (m² K)
- Latent heat of vaporization (h_{fg})= 213 kJ/kg
- Loss of oxygen (\dot{m})= 1.0 kg/day=1/86400 kg/sec

FIND

- Suitable layer of insulation and its thickness.

ASSUMPTIONS

- Steady state conditions persist
- The insulation is uniform.
- Properties remain constant.

SKETCH

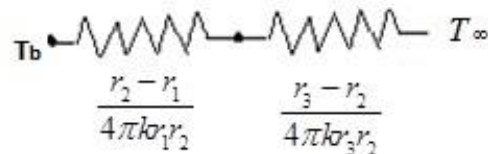
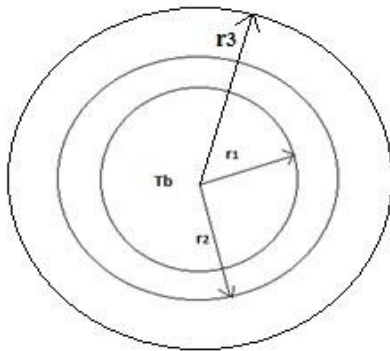

PROPERTIES AND CONSTANTS

From Appendix 2, Table 10, Thermal conductivity of stainless steel (k_s) = 14.4 W/(m² K).

The material with lowest conductivity available is selected pertaining to light weight requirement for spacecraft. From Appendix 2, Table 11, glass fiber is selected with conductivity of (k_g)=0.035 W/ (m K).

SOLUTION

The inner and outer radius of the stainless steel sphere is

$$r_1 = 0.5 - 0.01 = 0.49 \text{ m}$$

$$r_2 = 0.5 \text{ m}$$

$$r_3 = 0.5 + 0.1 = 0.6 \text{ m}$$

The rate of heat loss by vaporization is given by

$$\dot{q} = 1/86400 * 213 * 1000 \text{ J/sec} = 2.465 \text{ W}$$

This amount should be equal to heat loss by conduction through the sphere. Thus

$$2.465 = \frac{225 - 90}{\left(\frac{0.50 - 0.49}{4 * \pi * 14.4 * 0.50 * 0.49} \right) + \left(\frac{0.6 - 0.5}{4 * \pi * k_s * 0.5 * 0.6} \right) + \left(\frac{1}{4 * \pi * 5 * 0.6^2} \right)} \text{ W}$$

$$\dot{q} =$$

$$\frac{T_\infty - T}{\left(\frac{r_2 - r_1}{2 * \pi * k_s * r_1 * r_2} \right) + \left(\frac{r_3 - r_2}{2 * \pi * k_g} \right)}$$

$$2.465 = \frac{225 - 90}{\left(\frac{0.50 - 0.49}{4 * \pi * 14.4 * 0.50 * 0.49} \right) + \left(\frac{0.6 - 0.5}{4 * \pi * k_s * 0.5 * 0.6} \right) + \left(\frac{1}{4 * \pi * 5 * 0.6^2} \right)} \text{ W}$$

$$2.465 * \left(0.000225 + \frac{0.0265}{k} + 0.04421 \right) = 135$$

$$\left(\frac{0.0265}{k} \right) = 54.767 - 0.044$$

$k=0.0265/54.723 \text{ W/(m K)}$

$=0.000484 \text{ W/(m K)}$

COMMENTS

Currently no material is available whose conductivity is as low as 0.000484 W/(m K) . Scientists are working on developing low conductivity material so that the thickness of insulation material required reduces which is critical for developing light weight spacecraft.

PROBLEM 2.36

The development of contact lenses has transformed the solutions that are available today for vision impairments. However, wearing them also poses several problems that includes the condition of dry eyes due to lack of cooling, oxygenation, and moisturizing or lubrication of cornea, among others. In a development phase of a new protective liquid for contact lenses, the optometrist would like to know rate of heat loss from the anterior chamber of the eye through the cornea and the contact lens. The system is modelled as a partial hollow sphere, as shown in schematic diagram. The inner and outer radius of the cornea are respectively $r_1=10$ mm and $r_2=12.5$ mm, and the outer radius of the fitted contact lens is $r_3=14.5$ mm. The anterior chamber, which contains the aqueous humor that provides nutrients to the cornea (as the later tissue has no blood vessels), exposes the inner surface of the cornea to a temperature of $T_i=36.9^\circ\text{C}$ with a convective heat transfer coefficient of $h_i=10$ W/(m² K). The thermal conductivity of transparent tissue of cornea is 0.35 W/(m K), and that of the contact lens material is 0.8 W/(m K). The outer surface of the contact lens is exposed to room air at $T_0=22^\circ\text{C}$ and has a convection coefficient of $h_0=5$ W/(m² K). Draw a thermal circuit for the system showing all of the temperature potentials and thermal resistances. Then estimate the rate of heat loss from the anterior eye assuming that steady state exists and eye aperture spherical angle is of 100° .

GIVEN

- Inner radius of cornea $r_1=10$ mm=0.01 m
- Outer radius of cornea $r_2=12.5$ mm=0.0125 m
- Radius of contact lens $r_3=14.5$ mm=0.0145 m
- Inner cornea temperature $T_i=36.9^\circ\text{C}$
- Inner convective heat transfer coefficient $h_i=10$ W/(m² K)
- Conductivity of cornea tissue (k_1)=0.35 W/(m K)
- Conductivity of lens material (k_2)=0.8 W/(m K)
- Room air temperature $T_0=22^\circ\text{C}$
- Outer convection coefficient of $h_0=5$ W/(m² K)

FIND

- Draw thermal circuit showing all temperature potentials and thermal resistances
- Estimate rate of heat loss from anterior eye.

ASSUMPTIONS

- Steady state conditions persist
- Properties remain constant.
- Eye is treated as partial hollow sphere sweeping an angle of $\theta =100^\circ$

SKETCH

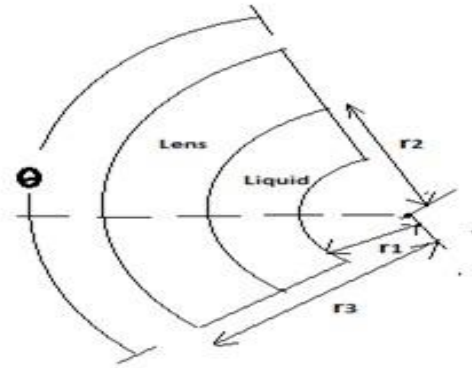

PROPERTIES AND CONSTANTS

From Appendix 2, Table 10, Thermal conductivity of stainless steel (k)= 14.2 W/(m² K)

SOLUTION

Since solid angle for complete sphere is 720° or 4π the surface area reduces by the factor of $\frac{\theta}{720}$ and thus

resistances increase by the factor of $\frac{720}{\theta}$.

The thermal circuit diagram for the problem is given as follows

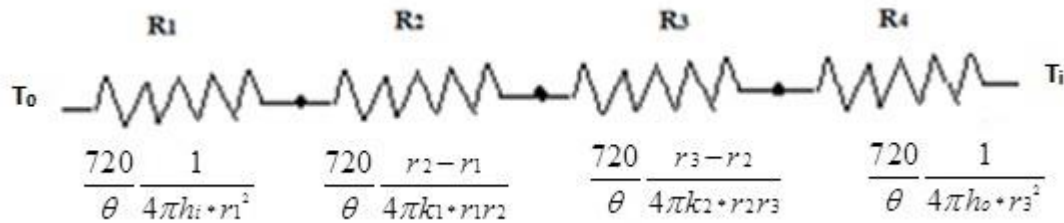

Total heat loss with the lens is given by

$$\dot{q} = \frac{T_i - T_0}{R_{total}}$$

$$R_{total} = R_1 + R_2 + R_3 + R_4$$

$$R_1 = \frac{720}{\theta} \frac{1}{4\pi h_i r_1^2} = 7.2 * \frac{1}{4\pi * 10 * 0.01^2} = 573 \text{ K/W}$$

$$R_2 = \frac{720}{\theta} \frac{r_2 - r_1}{4\pi k_1 r_1 r_2} = 7.2 * \frac{0.0125 - 0.01}{4\pi * 0.35 * 0.0125 * 0.01} = 32.74 \text{ K/W}$$

$$R_3 = \frac{720}{\theta} \frac{r_3 - r_2}{4\pi k_2 r_2 r_3} = 7.2 * \frac{0.0145 - 0.0125}{4\pi * 0.8 * 0.0145 * 0.0125} = 7.9 \text{ K/W}$$

$$R_4 = \frac{720}{\theta} \frac{1}{4\pi h_o r_3^2} = 7.2 * \frac{1}{4\pi * 5 * 0.0145^2} = 545 \text{ K/W}$$

$$R_{total} = R_1 + R_2 + R_3 + R_4 = 1158.64 \text{ K/W}$$

Total heat loss with the lens is

$$\dot{q} = \frac{T_i - T_0}{R_{total}} = \frac{36.9 - 22}{1158.64} \text{ W} = 0.0129 \text{ W}$$

PROBLEM 2.37

In cryogenic surgery, a small spherical probe is brought into contact with the diseased tissue which is frozen and thereby destroyed. One such probe can be modeled as a 3-mm diameter sphere whose surface is maintained at 240 K when the surrounding tissue is at 314 K. During the surgical procedure, a thin layer of tissue freezes around the probe at a temperature of 273 K. Assuming that the thermal conductivity of a frozen tissue is 1.5 W/(m K) and the heat transfer mechanism at the surface is described by the effective convective coefficient of 50 W/(m² K), estimate the thickness of frozen tissue formed during a 30 min long operation.

GIVEN

- Diameter of sphere(D_1)= 3 mm, $r_1=0.0015$ m
- Probe surface temperature(T_p)= 240 K
- Surrounding tissue temperature(T_t)= 314 K
- Tissue freezing temperature(T_f)= 273 K
- Thermal conductivity of frozen tissue(k_f)= 1.5 W/(m K)
- Effective convective coefficient (h)=50 W/(m² K)
- Operation time (t)= 30 min

FIND

- Thickness of a frozen tissue formed

ASSUMPTIONS

- 1 dimensional Steady state conditions persist
- Negligible contact resistance between probe and frozen tissue.
- Constant properties.

SKETCH

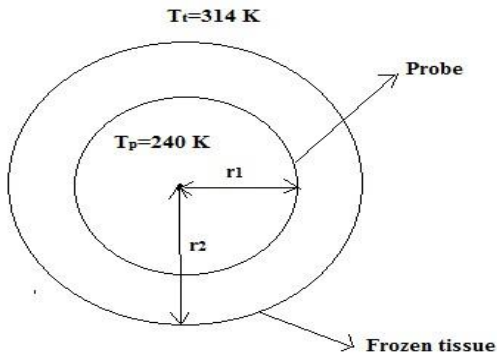

SOLUTION

The thermal circuit diagram for the given as follows

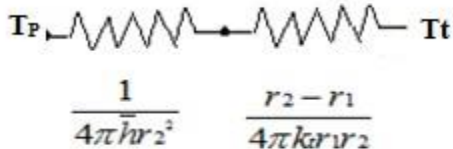

The thickness of tissue in 30 mins is obtained by energy balance that is when rate of heat loss through conduction is equal to rate of heat loss through convection, which means

$$\dot{q}_{\text{conduction}} = \dot{q}_{\text{convection}}$$

If r_2 is the radius of frozen tissue at 30 mins

The convection heat loss

$$\dot{q}_{\text{convection}} = \bar{h} * 4\pi r_2^2 (T_t - T_f) = 50 * 4\pi * r_2^2 * (314 - 273) = 25761 r_2^2$$

Conduction heat loss is given by

$$\dot{q}_{\text{conduction}} = \frac{T_f - T_p}{\frac{r_2 - r_1}{4\pi k_f r_1 r_2}} = \frac{273 - 240}{4\pi * 1.5 * 0.0015 * r_2} = \frac{0.933 r_2}{r_2 - 0.0015}$$

Equating above two equations we get

$$25761 r_2^2 = \frac{0.933 r_2}{r_2 - 0.0015}$$

$$25761 * r_2 = \frac{0.933}{r_2 - 0.0015}$$

Solving the above equation, we get $r_2 = 0.007$ m or 7 mm.

Thus the thickness of frozen tissue $= r_2 - r_1 = 5.5$ mm

EXTENDED SURFACES OR FINS

PROBLEM 2.38

The addition of aluminum fins has been suggested to increase the rate of heat dissipation from one side of an electronic device 1-m-wide and 1-m-tall. The fins are to be rectangular in cross section, 2.5-cm-long and 0.25-cm-thick. There are to be 100 fins per meter. The convective heat transfer coefficient, both for the wall and the fins, is estimated at 35 W/(m² K). With this information, determine the per cent increase in the rate of heat transfer of the finned wall compared to the bare wall.

GIVEN

- Aluminum fins with a rectangular cross section
- Dimensions: 2.5-cm-long and 0.25-mm-thick
- Number of fins per meter = 100
- The convective heat transfer coefficient (\bar{h}_c) = 35 W/(m² K)

FIND

- The per cent increase in the rate of heat transfer of the finned wall compared to the bare wall

ASSUMPTIONS

- Steady state heat transfer

SKETCH

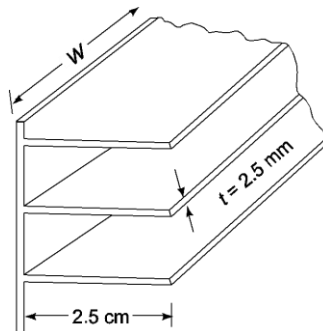

PROPERTIES AND CONSTANTS

From Appendix 2, Table 12

The thermal conductivity of aluminum (k) = 240 W/(m K) at 127°C

SOLUTION

Since the fins are of uniform cross section, Table 2.1 can be used to calculate the heat transfer rate from a single fin with convection at the tip

$$q_f = M \frac{\sinh(mL) + \frac{\bar{h}_c}{(mk)} \cosh(mL)}{\cosh(mL) + \left(\frac{\bar{h}_c}{mk}\right) \sinh(mL)}$$

where

$$M = \sqrt{\bar{h}_c P k A} \quad \theta_s = \sqrt{\bar{h}_c 2(t+w) k (tw)} \quad \theta_s$$

$$\theta_s = T_s - T_\infty$$

For a 1 m width ($w = 1$ m)

$$M = \sqrt{\frac{35 \text{ W}/(\text{m}^2 \text{ K}) \cdot 2(1.0025 \text{ m})}{240 \text{ W}/(\text{m K})}} \cdot (0.025 \text{ m}^2) \theta_s = 6.49 \theta_s \text{ W/K}$$

$$m L = \sqrt{\frac{\bar{h}_c P}{k A}} = L \sqrt{\frac{\bar{h}_c 2(t+w)}{k (tw)}} = 0.025 \text{ m} \sqrt{\frac{35 \text{ W}/(\text{m}^2 \text{ K}) \cdot 2(1.0025 \text{ m})}{240 \text{ W}/(\text{m K}) \cdot (0.0025 \text{ m}^2)}}$$

$$L m = 0.025 \text{ m} \left(10.81 \frac{1}{\text{m}} \right) = 0.270$$

$$\frac{\bar{h}_c}{\text{m K}} = \frac{35 \text{ W}/(\text{m}^2 \text{ K})}{\left(10.81 \frac{1}{\text{m}} \right) 240 \text{ W}/(\text{m K})} = 0.0135$$

Therefore, the rate of heat transfer from one fin, 1-meter-wide is:

$$q_f = 6.49 \theta_s \text{ W/K} \frac{\sinh(0.27) + 0.0135 \cosh(0.27)}{\cosh(0.27) + 0.0135 \sinh(0.27)}$$

$$q_f = 1.792 \theta_s \text{ W/K}$$

In 1 m^2 of wall area there are 100 fins covering $100 \cdot tw = 100 \cdot (0.0025 \text{ m}) \cdot (1 \text{ m}) = 0.25 \text{ m}^2$ of wall area leaving 0.75 m^2 of bare wall. The total rate of heat transfer from the wall with fins is the sum of the heat transfer from the bare wall and the heat transfer from 100 fins.

$$q_{\text{tot}} = q_{\text{bare}} + 100 q_{\text{fin}} = \bar{h} A_{\text{bare}} \theta_s + 100 q_{\text{fin}}$$

$$q_{\text{tot}} = 35 \text{ W}/(\text{m}^2 \text{ K}) \cdot (0.75 \text{ m}^2) \theta_s + 100 \cdot (1.792) \theta_s \text{ W/K} = 205.3 \theta_s \text{ W/K}$$

The rate of heat transfer from the wall without fins is

$$q_{\text{bare}} = \bar{h}_c A \theta_s = 35 \text{ W}/(\text{m}^2 \text{ K}) \cdot (1 \text{ m}^2) \theta_s = 35.0 \text{ W/K}$$

The percent increase due to the addition of fins is

$$\% \text{ increase} = \frac{205.3 - 35}{35} \times 100 = 486\%$$

COMMENTS

This problem illustrates the dramatic increase in the rate of heat transfer that can be achieved with properly designed fins.

The assumption that the convective heat transfer coefficient is the same for the fins and the wall is an oversimplification of the real situation, but does not affect the final results appreciably. In later chapters, we will learn how to evaluate the heat transfer coefficient from physical parameters and the geometry of the system.

PROBLEM 2.39

The tip of a soldering iron consists of a 0.6-cm diameter copper rod, 7.6 cm long. If the tip must be 204°C, what are the required minimum temperature of the base and the heat flow, in watts, into the base? Assume that $h = 22.7 \text{ W}/(\text{m}^2 \text{ K})$ and $T_{\text{air}} = 21^\circ\text{C}$.

GIVEN

- Tip of soldering iron consists of copper rod
- Outside diameter (D) = 0.6 cm = 0.006 m
- Length (L) = 7.6 cm = 0.076 m
- Temperature of the tip (T_L) = 204°C
- Heat transfer coefficient (\bar{h}) = 22.7 W/(m² K)
- Ambient temperature (T_∞) = 21°C

FIND

- Minimum temperature of the base (T_s)
- Heat flow into the base (q) in W

ASSUMPTIONS

- The tip is in steady state
- The thermal conductivity of copper is uniform and constant, i.e., not a function of temperature
- The copper tip can be treated as a fin

SKETCH

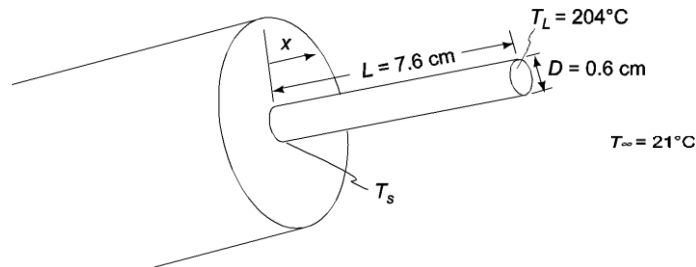

PROPERTIES AND CONSTANTS

From Appendix 2, Table 12

The thermal conductivity of copper (K) = 388 W/(m K) at 227°C

SOLUTION

- From Table 2.1, the temperature distribution for a fin with a uniform cross section and convection from the tip is

$$\frac{\theta}{\theta_s} = \frac{\cosh[m(L-x)] + \left(\frac{\bar{h}}{mk}\right) \sinh[m(L-x)]}{\cosh(mL) + \left(\frac{\bar{h}}{mk}\right) \sinh(mL)}$$

where

$$\theta = T - T_\infty \text{ and } \theta_s = \theta(0) = T_s - T_\infty$$

$$L m = L \sqrt{\frac{\bar{h} P}{kA}} = L \sqrt{\frac{\bar{h} \pi D}{k \frac{\pi}{4} D^2}} = \sqrt{\frac{4 \bar{h}}{k D}} = 0.076 \text{ m} \sqrt{\frac{4 \cdot 22.7 \text{ W}/(\text{m}^2 \text{ K})}{388 \text{ W}/(\text{m K}) (0.006 \text{ m})}}$$

$$L m = 0.076 \text{ m} \left(6.25 \frac{1}{\text{m}} \right) = 0.475$$

$$\frac{\bar{h}}{mK} = \frac{22.7 \text{ W}/(\text{m}^2 \text{ K})}{\left(6.25 \frac{1}{\text{m}} \right) 388 \text{ W}/(\text{m K})} = 0.00936$$

Evaluating the temperature at $x = L$

$$\frac{\theta_L}{\theta_s} = \frac{T_L - T_\infty}{T_s - T_\infty} = \frac{\cosh(0) + 0.00936 \sinh(0)}{\cosh(0.475) + 0.00936 \sinh(0.475)} = 0.8932$$

Solving for the base temperature

$$T_s = T_\infty + \frac{T_L - T_\infty}{0.8932} = 21^\circ \text{C} + \frac{204^\circ \text{C} - 21^\circ \text{C}}{0.8932} = 226^\circ \text{C}$$

(b) To maintain steady state conditions, the rate of heat transfer into the base must be equal to the rate of heat loss from the rod. From Table 2.1, the rate of heat loss is

$$q_f = M \frac{\sinh(mL) + \left(\frac{\bar{h}}{mk}\right) \cosh(mL)}{\cosh(mL) + \left(\frac{\bar{h}}{mk}\right) \sinh(mL)} \quad \text{where } M = \sqrt{\bar{h} P k A \theta_s} = \sqrt{\bar{h} k \frac{\pi^2}{4} D^3} (T_s - T_\infty)$$

$$M = \sqrt{22.7 \text{ W}/(\text{m}^2 \text{ K}) \cdot 388 \text{ W}/(\text{m K}) \cdot \frac{\pi^2}{4} (0.006 \text{ m})^3 (226^\circ \text{C} - 21^\circ \text{C})} = 14.045 \text{ W}$$

$$q_f = 14.045 \text{ W} \frac{\sinh(0.475) + .00936 \cosh(0.475)}{\cosh(0.475) + .00936 \sinh(0.475)} = 6.3 \text{ W}$$

COMMENTS

A small soldering iron such as this will typically be rated at 30 W to allow for radiation heat losses and more rapid heat-up.

PROBLEM 2.40

One end of a 0.3-m-long steel rod is connected to a wall at 204°C. The other end is connected to a wall that is maintained at 93°C. Air is blown across the rod so that a heat transfer coefficient of 17 W/(m² K) is maintained over the entire surface. If the diameter of the rod is 5 cm and the temperature of the air is 38°C, what is the net rate of heat loss to the air?

GIVEN

- A steel rod connected to walls at both ends
- Length of rod (L) = 0.3 m
- Diameter of the rod (D) = 5 cm = 0.05 m
- Wall temperatures
 - $T_s = 204^\circ\text{C}$
 - $T_L = 93^\circ\text{C}$
- Heat transfer coefficient (\bar{h}_c) = 17 W/(m² K)
- Air temperature (T_∞) = 38°C

FIND

The net rate of heat loss to the air (q_f)

ASSUMPTIONS

- The wall temperatures are constant
- The system is in steady state
- The rod is 1% carbon steel
- The thermal conductivity of the rod is uniform and not dependent on temperature
- One dimensional conduction along the rod

SKETCH

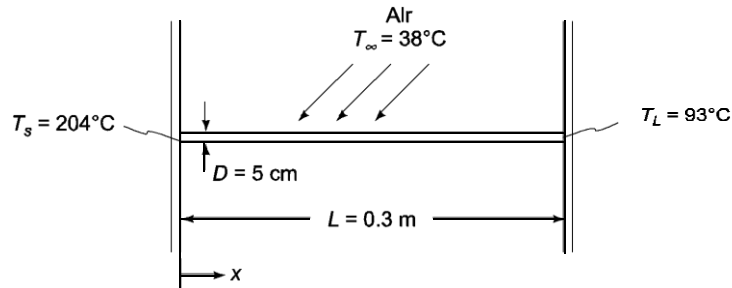

PROPERTIES AND CONSTANTS

From Appendix 2, Table 10

The thermal conductivity of 1% carbon steel (k) = 43 W/(m K) (at 20°C)

SOLUTION

The rod can be idealized as a fin of uniform cross section with fixed temperatures at both ends. From Table 2.1 the rate of heat loss is

$$q_f = M \frac{\cos h(mL) - \left(\frac{\theta}{\theta_s}\right)}{\sin h(mL)}$$

where $\theta_L = T_L - T_\infty = 93^\circ\text{C} - 38^\circ\text{C} = 55^\circ\text{C}$ and $\theta_s = T_s - T_\infty = 204^\circ\text{C} - 38^\circ\text{C} = 166^\circ\text{C}$

$$L m = L \sqrt{\frac{\bar{h}_c P}{kA}} = L \sqrt{\frac{\bar{h}_c \pi D}{k \frac{\pi}{4} D^2}} = L \sqrt{\frac{4 \bar{h}_c}{kD}} = 0.3 \text{ m} \sqrt{\frac{4 \cdot 17 \text{ W}/(\text{m}^2 \text{ K})}{43 \text{ W}/(\text{m K}) (0.05 \text{ m})}} = 1.687$$

$$M = \sqrt{\bar{h} P k A} \quad \theta_s = \sqrt{h \frac{\pi^2}{4} D^3 k} \quad \theta_s = \sqrt{17 \text{ W}/(\text{m}^2 \text{ K}) \frac{\pi^2}{4} (0.05 \text{ m})^3 43 \text{ W}/(\text{m K})} \quad (166^\circ\text{C}) = 78.82 \text{ W}$$

$$q_f = 78.82 \text{ W} \frac{\cosh(1.687) - \frac{55}{166}}{\sinh(1.687)} = 74.4 \text{ W}$$

COMMENTS

In a real situation the convective heat transfer coefficient will not be uniform over the circumference. It will be higher over the side facing the air stream. But because of the high thermal conductivity, the temperature at any given section will be nearly uniform.

PROBLEM 2.41

Both ends of a 0.6-cm copper U-shaped rod, are rigidly affixed to a vertical wall as shown in the accompanying sketch. The temperature of the wall is maintained at 93°C. The developed length of the rod is 0.6 m, and it is exposed to air at 38°C. The combined radiation and convection heat transfer coefficient for this system is 34 W/(m² K). (a) Calculate the temperature of the midpoint of the rod. (b) What will the rate of heat transfer from the rod be?

GIVEN

- U-shaped copper rod rigidly affixed to a wall
- Diameter (D) = 0.6 cm = 0.006 m
- Developed length (L) = 0.6 m
- Wall temperature is constant at (T_s) = 93°C
- Air temperature (T_∞) = 38°C
- Heat transfer coefficient (\bar{h}) = 34 W/(m² K)

FIND

- Temperature of the midpoint (T_{L_f})
- Rate of heat transfer from the rod (M)

ASSUMPTIONS

- The system is in steady state
- Variation in the thermal conductivity of copper is negligible
- The U-shaped rod can be approximated by a straight rod of equal length
- Uniform temperature across any section of the rod

SKETCH

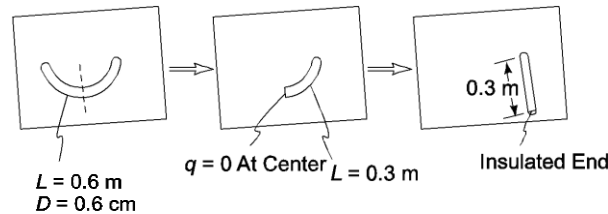

PROPERTIES AND CONSTANTS

From Appendix 2, Table 12, thermal conductivity of copper (k) = 396 W/(m² K) at 64°C

SOLUTION

By symmetry, the conduction through the rod at the center must be zero. Therefore, the rod can be thought of as two pin fins with insulated ends as shown in the sketch above.

- From Table 2.1, the temperature distribution for a fin of uniform cross section with an adiabatic tip is

$$\frac{\theta}{\theta_s} = \frac{\cosh[m(L_f - x)]}{\cosh(mL)}$$

where $\theta = T - T_\infty$, $\theta_s = T_s - T_\infty$ and L_f = length of the fin

$$m = \sqrt{\frac{\bar{h}P}{kA}} = \sqrt{\frac{\bar{h} \pi D}{k \left(\frac{\pi}{4} D^2 \right)}} = \sqrt{\frac{4\bar{h}}{kD}} = \sqrt{\frac{4 \cdot 34 \text{ W}/(\text{m}^2 \text{ K})}{396 \text{ W}/(\text{m K}) (0.006 \text{ m})}} = 7.57 \frac{1}{\text{m}}$$

Evaluating the temperature of the tip of the pin fin

$$\frac{\theta(L_f)}{\theta_s} = \frac{\cosh[m(L_f - L_f)]}{\cosh(mL_f)} = \frac{1}{\cosh(mL_f)}$$

The length of the fin is half of the wire length ($L_f = 0.3$ m)

$$\frac{\theta(L_f)}{\theta_s} = \frac{T(L_f) - T_\infty}{T_s - T_\infty} = \frac{1}{\cosh\left[7.57 \frac{1}{\text{m}}(0.3\text{m})\right]} = 0.205$$

$$T(L_f) = 0.205 (T_s - T_\infty) + T_\infty = 0.205 (93^\circ\text{C} - 38^\circ\text{C}) + 38^\circ\text{C} = 49.2^\circ\text{C}$$

The temperature at the tip of the fin is the temperature at the midpoint of the curved rod (49.2°C).

(b) From Table 2.1, the heat transfer from the fin is

$$q_{\text{fin}} = M \tanh(mL_f)$$

where $M = \sqrt{hPkA}$ $\theta_s = \sqrt{h(\pi D)k} \left(\frac{\pi D^2}{4}\right) (T_s - T_\infty)$

$$M = \sqrt{\frac{\pi}{4} 34\text{W}/(\text{m}^2\text{K}) \quad 396\text{W}/(\text{m K}) \quad (0.006\text{m})^3} (93^\circ\text{C} - 38^\circ\text{C}) = 4.653 \text{ W}$$

$$\therefore q_{\text{fin}} = 4.653 \text{ W} \tanh\left(7.57 \frac{1}{\text{m}}\right) (0.3 \text{ m}) = 4.56 \text{ W}$$

The rate of heat transfer from the curved rod is approximately twice the heat transfer of the pin fin

$$q_{\text{rod}} = 2 q_{\text{fin}} = 2(4.56 \text{ W}) = 9.12 \text{ W}$$

PROBLEM 2.42

A circumferential fin of rectangular cross section, 3.7-cm-OD and 0.3-cm-thick surrounds a 2.5-cm-diameter tube as shown below. The fin is constructed of mild steel. Air blowing over the fin produces a heat transfer coefficient of 28.4 W/(m² K). If the temperatures of the base of the fin and the air are 260°C and 38°C, respectively, calculate the heat transfer rate from the fin.

GIVEN

- A mild steel circumferential fin of a rectangular cross section on a tube
- Tube diameter (D_t) = 2.5 cm = 0.025 m
- Fin outside diameter (D_f) = 3.7 cm = 0.037 m
- Fin thickness (t) = 0.3 cm = 0.003 m
- Heat transfer coefficient (\bar{h}_c) = 28.4 W/(m² K)
- Fin base temperature (T_s) = 260°C
- Air temperature (T_∞) = 38°C

FIND

- The rate of heat transfer from the fin (q_{fin})

ASSUMPTIONS

- The system has reached steady state
- The mild steel is 1% carbon steel
- The thermal conductivity of the steel is uniform
- Radial conduction only (temperature is uniform across the cross section of the fin)
- The heat transfer from the end of the fin can be accounted for by increasing the length by half the thickness and assuming the end is insulated

SKETCH

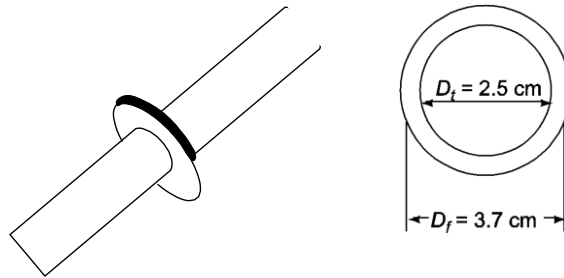

PROPERTIES AND CONSTANTS

Thermal conductivity of 1% carbon steel (k) = 43 W/(m K) at 20°C

SOLUTION

The rate of heat transfer for the fin can be calculated using the fin efficiency determined from the efficiency graph for this geometry, Figure 2.17.

The length of a fin (L) = $(D_f - D_t)/2 = 0.006$ m

The parameters needed are

$$r_i = \frac{D_t}{2} = 0.125 \text{ m} \quad r_o = \frac{D_f}{2} + L = 0.125 \text{ m} + 0.006 \text{ m} = 0.0185 \text{ m}$$

$$\left(r_o + \frac{t}{2} - r_i\right)^{\frac{3}{2}} = \left(\frac{2\bar{h}_c}{k t(r_o - r_i)}\right)^{\frac{1}{2}} \left(0.0815 \text{ m} + \frac{0.003 \text{ m}}{2} - 0.0125 \text{ m}\right)^{\frac{3}{2}}$$

$$\left(\frac{r_o + \frac{t}{2}}{r_i}\right) = \frac{0.0185 \text{ m} + 0.0015 \text{ m}}{0.0125 \text{ m}} = 1.6$$

$$\left(\frac{2 \cdot 28.4 \text{ W}/(\text{m}^2 \text{ K})}{43 \text{ W}/(\text{m K}) (0.003 \text{ m})(0.0185 \text{ m} - 0.0125 \text{ m})}\right)^{\frac{1}{2}} = 0.176$$

From Figure 2.17, the fin efficiency for these parameters is:

$$\eta_f = 98\%$$

The rate of heat transfer from the fin is

$$q_{\text{fin}} = \eta_f \bar{h}_c A_{\text{fin}} (T_s - T_\infty) = \eta_f \bar{h}_c 2\pi \left[\left(r_o + \frac{t}{2}\right)^2 - r_i^2 \right] (T_s - T_\infty)$$

$$q_{\text{fin}} = (0.98) \cdot 28.4 \text{ W}/(\text{m}^2 \text{ K}) \cdot 2\pi [(0.085 \text{ m} + 0.0015 \text{ m})^2 - (0.0125 \text{ m})^2] (260^\circ\text{C} - 38^\circ\text{C}) = 9.46 \text{ W}$$

PROBLEM 2.43

A turbine blade 6.3-cm-long, with cross-sectional area $A = 4.6 \times 10^{-4} \text{ m}^2$ and perimeter $P = 0.12 \text{ m}$, is made of stainless steel ($k = 18 \text{ W/(m K)}$). The temperature of the root, T_s , is 482°C . The blade is exposed to a hot gas at 871°C , and the heat transfer coefficient h is $454 \text{ W/(m}^2 \text{ K)}$. Determine the temperature of the blade tip and the rate of heat flow at the root of the blade. Assume that the tip is insulated.

GIVEN

- Stainless steel turbine blade
- Length of blade (L) = 6.3 cm = 0.063 m
- Cross-sectional area (A) = $4.6 \times 10^{-4} \text{ m}^2$
- Perimeter (P) = 0.12 m
- Thermal conductivity (k) = 18 W/(m K)
- Temperature of the root (T_s) = 482°C
- Temperature of the hot gas (T_∞) = 871°C
- Heat transfer coefficient (\bar{h}_c) = $454 \text{ W/(m}^2 \text{ K)}$

FIND

- The temperature of the blade tip (T_L)
- The rate of heat flow (q) at the roof of the blade

ASSUMPTIONS

- Steady state conditions prevail
- The thermal conductivity is uniform
- The tip is insulated
- The cross-section of the blade is uniform
- One dimensional conduction

SKETCH

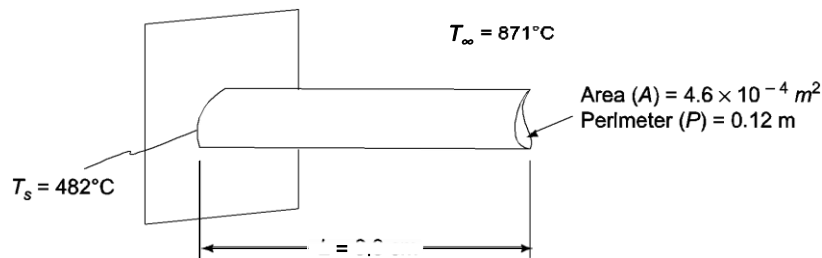

SOLUTION

- The temperature distribution in a fin of uniform cross-section with an insulated tip, from Table 2.1, is

$$\frac{\theta}{\theta_s} = \frac{\cosh[m(L-x)]}{\cosh(mL)}$$

where $m = \sqrt{\frac{\bar{h} P}{k A}} = \sqrt{\frac{454 \text{ W/(m}^2 \text{ K)}(0.12 \text{ m})}{18 \text{ W/(m K)}(4.6 \times 10^{-4} \text{ m}^2)}} = 81.1 \frac{1}{\text{m}}$

$$\theta = T - T_\infty$$

At the blade tip, $x = L$, therefore

$$\frac{\theta_L}{\theta_s} = \frac{T_L - T_\infty}{T_s - T_\infty} = \frac{\cosh[m(0)]}{\cosh(mL)} = \frac{1}{\cosh(mL)}$$

$$T_L = T_\infty + \frac{T_s - T_\infty}{\cosh(mL)} = 871^\circ\text{C} + \frac{482^\circ\text{C} - 871^\circ\text{C}}{\cosh\left[\left(\frac{1}{81.1 \frac{\text{m}}{\text{K}}}\right)(0.063 \text{ m})\right]} = 866^\circ\text{C}$$

(b) The rate of heat transfer from the fin is given by Table 2.1 to be

$$q = M \tanh(mL)$$

where

$$M = \sqrt{h_c P k A} \theta_s$$

$$M = \sqrt{454 \text{ W}/(\text{m}^2 \text{ K})(0.12 \text{ m}) 18 \text{ W}/(\text{m K}) (4.6 \times 10^{-4} \text{ m}^2) (482^\circ\text{C} - 871^\circ\text{C})} = -261 \text{ W}$$

$$\therefore q = (-261 \text{ W}) \tanh\left[81.1 \frac{1}{\text{m}}(0.063 \text{ m})\right] = -261 \text{ W (out of the blade)}$$

COMMENTS

In a real situation, the heat transfer coefficient will vary over the surface with the highest value near the leading edge. But because of the high thermal conductivity of the blade, the temperature at any section will be essentially uniform.

PROBLEM 2.44

To determine the thermal conductivity of a long, solid 2.5 cm diameter rod, one half of the rod was inserted into a furnace while the other half was projecting into air at 27°C. After steady state had been reached, the temperatures at two points 7.6 cm apart were measured and found to be 126°C and 91°C, respectively. The heat transfer coefficient over the surface of the rod exposed to the air was estimated to be 22.7 W/(m² K). What is the thermal conductivity of the rod?

GIVEN

- A solid rod, one half inserted into a furnace
- Diameter of rod (D) = 2.5 cm = 0.025 m
- Air temperature (T_∞) = 27°C
- Steady state has been reached
- Temperatures at two points 7.6 cm apart
 - $T_1 = 126^\circ\text{C}$
 - $T_2 = 91^\circ\text{C}$
- The heat transfer coefficient (\bar{h}_c) = 22.7 W/(m² K)

FIND

- The thermal conductivity (k) of the rod

ASSUMPTIONS

- Uniform thermal conductivity
- One dimensional conduction along the rod
- The rod approximates a fin of infinite length protruding out of the furnace

SKETCH

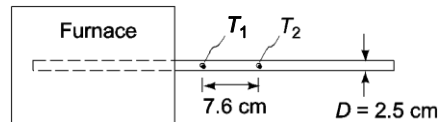

SOLUTION

This problem can be visualized as the following pin fin problem shown below

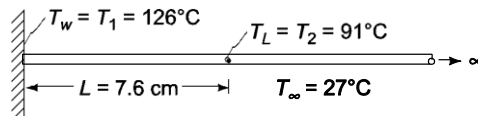

The fin is of uniform cross section, therefore Table 2.1 can be used. The temperature distribution for a fin of infinite length, from Table 2.1, is

$$\frac{\theta}{\theta_s} = e^{-mx}$$

$$\text{where } m = \sqrt{\frac{\bar{h}_c P}{kA}} = \sqrt{\frac{\bar{h}_c \pi D}{k \frac{\pi D^2}{4}}} = \sqrt{\frac{4\bar{h}_c}{kD}}$$

Substituting this into the temperature distribution and solving for k

$$\frac{\theta}{\theta_s} = \exp\left(-\sqrt{\frac{4\bar{h}_c}{kD}} x\right) \Rightarrow k = \frac{4\bar{h}_c}{D\left(\frac{\ln \frac{\theta}{\theta_s}}{x}\right)^2}$$

at $x = L$

$$\theta_L = T_L - T_\infty = 91^\circ\text{C} - 27^\circ\text{C} = 64^\circ\text{C}$$

$$\theta_s = T_W - T_\infty = 126^\circ\text{C} - 27^\circ\text{C} = 99^\circ\text{C}$$

$$\frac{\theta_L}{\theta_s} = \frac{64}{99} = 0.6465$$

Therefore

$$k = \frac{4 \cdot 22.7 \text{ W}/(\text{m}^2 \text{ K})}{0.025 \left[\frac{\ln(0.6465)}{0.076 \text{ m}} \right]^2} = 110 \text{ W}/(\text{m K})$$

COMMENTS

Note that this procedure can only be used if the assumption of an infinite length fin is valid. Otherwise, the location of the temperature measurements along the fin must be specified to determine the thermal conductivity.

PROBLEM 2.45

Heat is transferred from water to air through a brass wall ($k = 54 \text{ W/(m K)}$). The addition of rectangular brass fins, 0.08-cm-thick and 2.5-cm-long, spaced 1.25 cm apart, is contemplated. Assuming a water-side heat transfer coefficient of $170 \text{ W/(m}^2 \text{ K)}$ and an air-side heat transfer coefficient of $17 \text{ W/(m}^2 \text{ K)}$, compare the gain in heat transfer rate achieved by adding fins to: (a) the water side, (b) the air side, and (c) both sides. (Neglect temperature drop through the wall.)

GIVEN

- A brass wall with brass fins between air and water
- Thermal conductivity of the brass (k) = 54 W/(m K)
- Fin thickness (t) = $0.08 \text{ cm} = 0.0008 \text{ m}$
- Fin length (L) = $2.5 \text{ cm} = 0.025 \text{ m}$
- Fin spacing (d) = $1.25 \text{ cm} = 0.0125 \text{ m}$
- Water-side heat transfer coefficient (\bar{h}_{cw}) = $170 \text{ W/(m}^2 \text{ K)}$
- Air-side heat transfer coefficient (\bar{h}_{ca}) = $17 \text{ W/(m}^2 \text{ K)}$

FIND

Compare the heat transfer rate with fins added to

- the water side, $q_{(a)}$
- the air side, $q_{(b)}$
- both sides, $q_{(c)}$

ASSUMPTIONS

- The thermal resistance of the wall is negligible
- Steady state conditions prevail
- Constant thermal conductivity
- One dimensional conduction
- Heat transfer from the tip of the fins is negligible

SKETCH

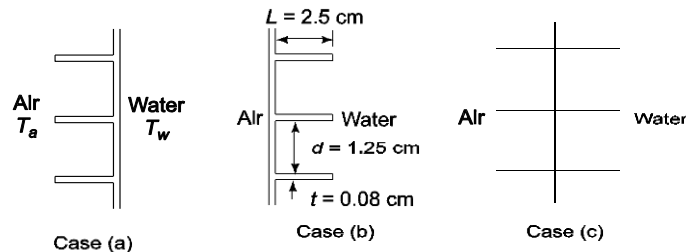

SOLUTION

The fins are of uniform cross-section, therefore Table 2.1 may be used. To simplify the analysis, the heat transfer from the end of the fin will be neglected. For a fin with adiabatic tip, the rate of heat transfer is

$$q_f = M \tanh(mL)$$

where $M = \sqrt{\bar{h}_c P k A} \theta_s = \sqrt{\bar{h}_c (2w) k (wt)} \theta_s = w \sqrt{2 \bar{h}_c k t} \theta_s$

$$m = \sqrt{\frac{\bar{h}_c P}{k A}} = \sqrt{\frac{\bar{h}_c (2w)}{k w t}} = \sqrt{\frac{2 \bar{h}_c}{k t}}$$

The number of fins per square meter of wall is

$$\frac{\text{number of fins}}{\text{m}^2} = \frac{1}{(0.0133\text{m/fin})1\text{m width}} = 75.2 \text{ fins/m}^2$$

Fraction of the wall area not covered by fins is

$$\frac{A_{\text{bare}}}{A_w} = \frac{1\text{m}^2 - 75.2 (1\text{-m-width})(0.008\text{m})}{\text{m}^2} = 0.939 \approx 0.94$$

The rate of heat transfer from the wall with fins is equal to the sum of the heat transfer from the bare wall and from the fins

$$q = \bar{h}_c A_{\text{bare}} \theta_s + (\text{number of fins}) [M \tanh (mL)]$$

$$q = \left[\bar{h}_c A_{\text{bare}} + 75.2 A_w \frac{M}{\theta} \tanh (mL) \right] \theta = \frac{\theta_s}{R_c}$$

where A_w is the total base area, i.e., with fins removed.

Therefore, the thermal resistance of a wall with fins based on a unit of base area is

$$R_c = \frac{1}{A_w \left[\bar{h}_c \frac{A_{\text{bare}}}{A_w} + 75.2 \frac{M}{\theta} \tanh (mL) \right]}$$

For fins on the water side

$$\frac{M_w}{\theta_s} = 1\text{-m-width} \sqrt{170\text{W}/(\text{m}^2\text{K})(2) \quad 54\text{W}/(\text{m K}) \quad (0.0008 \text{ m})} = 3.832 \text{ W/K}$$

$$m_w = \sqrt{\frac{2 \quad 170\text{W}/(\text{m}^2\text{K})}{54\text{W}/(\text{m K})(.0008 \text{ m})}} = 88.72 \frac{1}{\text{m}}$$

$$\tanh (m_a L) = \tanh \left(88.72 \frac{1}{\text{m}} \right) (0.025 \text{ m}) = 0.977$$

For fins on the air side

$$\frac{M_a}{\theta_s} = 1\text{-m-width} \sqrt{17\text{W}/(\text{m}^2\text{K}) (2) \quad 54\text{W}/(\text{m K}) \quad (0.0008)} = 1.212 \text{ W/K}$$

$$m_a = \sqrt{\frac{2 \quad 17\text{W}/(\text{m}^2\text{K})}{54\text{W}/(\text{m K}) \quad (0.0008 \text{ m})}} = 28.05 \frac{1}{\text{m}}$$

$$\tanh m_a L = \tanh \left(28.05 \frac{1}{\text{m}} \right) (0.025 \text{ m}) = 0.605$$

The thermal circuit for the problem is

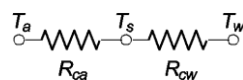

The values of thermal resistances with and without fins are

$$(R_{ca})_{\text{nofins}} = \frac{1}{A_w h_{ca}} = 1$$

$$\frac{A}{K} = \frac{17W}{0.0588(m^2 K)/W_A w}$$

$$(R_{cw})_{\text{nofins}} = \frac{1}{A_w h_{cw}} = \frac{1}{A_w 170 \text{ W}/(\text{m}^2 \text{ K})} = \frac{1}{A_w} 0.00588 (\text{m}^2 \text{ K})/\text{W}$$

$$(R_{ca})_{\text{fins}} = \frac{1}{A_w [17 \text{ W}/(\text{m}^2 \text{ K})(0.94) + 75.2 \text{ m}^{-2} 1.212 \text{ W}/\text{K} (0.605)]} = \frac{1}{A_w} 0.0141 (\text{m}^2 \text{ K})/\text{W}$$

$$(R_{cw})_{\text{fins}} = \frac{1}{A_w [170 \text{ W}/(\text{m}^2 \text{ K})(0.94) + 75.2 \text{ m}^{-2} 3.832 \text{ W}/\text{K} (0.977)]} = \frac{1}{A_w} 0.00227 (\text{m}^2 \text{ K})/\text{W}$$

(a) The rate of heat transfer with fins on the water side only is

$$q^{(a)} = \frac{T \Delta}{(R_{ca})_{\text{nofins}} + (R_{cw})_{\text{fins}}}$$

$$\frac{q^{(a)}}{A_w} = \frac{\Delta T}{(0.0588 + 0.00227)(\text{m}^2 \text{ K})/\text{W}} = 16.4 \Delta T \text{ W}/(\text{m}^2 \text{ K})$$

(b) The rate of heat transfer with fins on the air side only is

$$q^{(b)} = \frac{\Delta T}{(R_{ca})_{\text{fins}} + (R_{cw})_{\text{nofins}}}$$

$$\frac{q^{(b)}}{A_w} = \frac{\Delta T}{(0.0141 + 0.00588)(\text{m}^2 \text{ K})/\text{W}} = 50.1 \Delta T \text{ W}/(\text{m}^2 \text{ K})$$

(c) With fins on both sides, the rate of heat transfer is

$$q^{(c)} = \frac{\Delta T}{(R_{ca})_{\text{fins}} + (R_{cw})_{\text{nofins}}}$$

$$\frac{q^{(c)}}{A_w} = \frac{\Delta T}{(0.0141 + 0.00227)(\text{m}^2 \text{ K})/\text{W}} = 61.1 \Delta T \text{ W}/(\text{m}^2 \text{ K})$$

As a basis of comparison, the rate of heat transfer without fins on either side is:

$$\frac{q}{A_w} = \frac{T \Delta}{(0.0588 + 0.00588)(\text{m}^2 \text{ W})/\text{K}} = 15.5 \Delta T \text{ W}/(\text{m}^2 \text{ K})$$

The following percent increase over the no fins case occurs

Case	% Increase
(a) fins on water side	5.8
(b) fins on air side	223
(c) fins on both sides	294

COMMENTS

Placing the fins on the side with the larger thermal resistance, i.e., the air side, has a much greater effect on the rate of heat transfer.

The small gain in heat transfer rate achieved by placing fins on the water side only would most likely not be justified due to the high cost of attaching the fins.

PROBLEM 2.46

The wall of a liquid-to-gas heat exchanger has a surface area on the liquid side of 1.8 m^2 ($0.6 \text{ m} \times 3 \text{ m}$) with a heat transfer coefficient of $255 \text{ W}/(\text{m}^2 \text{ K})$. On the other side of the heat exchanger wall flows a gas, and the wall has 96 thin rectangular steel fins 0.5-cm-thick and 1.25-cm-high [$k = 3 \text{ W}/(\text{m K})$]. The fins are 3-m-long and the heat transfer coefficient on the gas side is $57 \text{ W}/(\text{m}^2 \text{ K})$. Assuming that the thermal resistance of the wall is negligible, determine the rate of heat transfer if the overall temperature difference is 38°C .

GIVEN

- The wall of a heat exchanger has 96 fins on the gas side
- Surface area on the liquid side (A_L) = 1.8 m^2 ($0.6 \text{ m} \times 3 \text{ m}$)
- Heat transfer coefficient on the liquid side (h_{cL}) = $255 \text{ W}/(\text{m}^2 \text{ K})$
- The wall has 96 thin steel fins 0.5-cm-thick and 1.25-cm-high
- Thermal conductivity of the steel (k) = $3 \text{ W}/(\text{m K})$
- Fin length (w) = 3 m , Fin height (L) = $1.25 \text{ cm} = 0.0125 \text{ m}$
- Fin thickness (t) = $0.5 \text{ cm} = 0.005 \text{ m}$
- Heat transfer coefficient on the gas side (h_{cG}) = $57 \text{ W}/(\text{m}^2 \text{ K})$
- The overall temperature difference (ΔT) = 38°C

FIND

- The rate of heat transfer (q)

ASSUMPTIONS

- The thermal resistance of the wall is negligible
- The heat transfer through the wall is steady state
- The thermal conductivity of the steel is constant

SKETCH

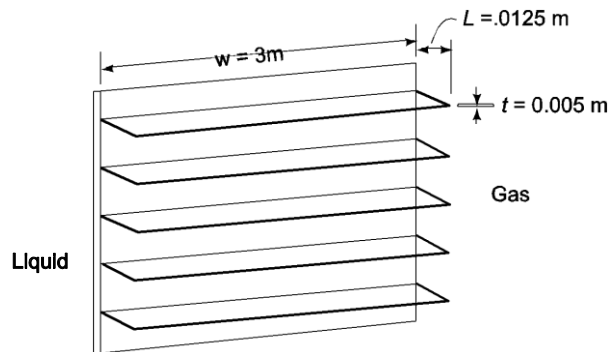

A Section of the Wall

SOLUTION

The heat transfer from a single fin can be calculated from Table 2.1 for a fin with convection from the tip

$$q_f = M \frac{\sinh(mL) + \left(\frac{h_c}{mk}\right) \cosh(mL)}{\cosh(mL) + \left(\frac{mk}{h_c}\right) \sinh(mL)}$$

where

$$m = \sqrt{\frac{h_c P}{kA}} = \sqrt{\frac{h_c (2t + 2w)}{k(wt)}} = \sqrt{\frac{57 \text{ W}/(\text{m}^2 \text{ K})(6 \text{ m} + 0.01 \text{ m})}{3 \text{ W}/(\text{m K})(3 \text{ m})(0.005 \text{ m})}} = 87.25 \frac{1}{\text{m}}$$

$$mL = 87.25 \frac{1}{\text{m}} (0.0125 \text{ m}) = 1.091 \text{ and } \frac{h_c}{mk} = \frac{57 \text{ W}/(\text{m}^2 \text{ K})}{87.25 \frac{1}{\text{m}} 3 \text{ W}/(\text{m K})} = 0.2178$$

$$M = \sqrt{\bar{h}_c P k A} \quad \theta_s = \sqrt{57 \text{ W}/(\text{m}^2 \text{ K}) (6.01 \text{ m}) 3 \text{ W}/(\text{m K}) (3 \text{ m})(0.005 \text{ m})} (T_s - T_g) = 3.926 (T_s - T_g) \text{ W/K}$$

$$q_f = 3.926 (T_s - T_g) \text{ W/K} \frac{\sinh(1.091) + 0.2178 \cosh(1.091)}{\cosh(1.091) + 0.2178 \sinh(1.091)} = 3.395 (T_s - T_g) \text{ W/K}$$

The rate of heat transfer on the gas side is the sum of the convection from the fins and the convection from the bare wall between the fins. The bare area is

$$\begin{aligned} A_{\text{bare}} &= A_{\text{wall}} - (\text{number of fins}) (\text{Area of one fin}) \\ &= 1.8 \text{ m}^2 - (96 \text{ fins}) [(3 \text{ m}) (0.005 \text{ m})/\text{fin}] = 0.36 \text{ m}^2 \end{aligned}$$

The total rate of heat transfer to the gas is

$$q_g = q_{\text{bare}} + (\text{number of fins}) q_f = \bar{h}_{cg} A_{\text{bare}} (T_s - T_g) + 96(3.395) (T_s - T_g) \text{ W/K}$$

$$q_g = [57 \text{ W}/(\text{m}^2 \text{ K})(0.36 \text{ m}^2) + 96(3.395)] (T_s - T_g) \text{ W/K} = 346.4 (T_s - T_g) \text{ W/K} = \frac{T_s - T_g}{R_g}$$

The thermal resistance on the gas side is

$$R_g = \frac{1}{346.4 \text{ K/W}} = 0.002887 \text{ K/W}$$

The thermal resistance on the liquid side is

$$R_L = \frac{1}{h_{cL} A_w} = \frac{1}{255 \text{ W}/(\text{m}^2 \text{ K}) (1.8 \text{ m}^2)} = 0.002179 \text{ K/W}$$

The rate of heat transfer is

$$q = \frac{\Delta T}{R_{\text{tot}}} = \frac{\Delta T}{R_g + R_L} = \frac{38^\circ \text{ C}}{(0.002887 + 0.002179) \text{ K/W}} = 7500 \text{ W}$$

COMMENTS

Note that despite the much lower heat transfer coefficient on the gas side, the thermal resistance is no larger than on the liquid side. This is the result of balancing the fin geometries which is a desirable situation from the thermal design perspective. Adding fins on the liquid side would not increase the rate of heat transfer appreciably.

PROBLEM 2.47

The top of a 30 cm I-beam is maintained at a temperature of 260°C, while the bottom is at 93°C. The thickness of the web is 1.25 cm. Air at 260°C is blowing along the side of the beam so that $\bar{h} = 40 \text{ W}/(\text{m}^2 \text{ K})$. The thermal conductivity of the steel may be assumed constant and equal to 43 W/(m K). Find the temperature distribution along the web from top to bottom and plot the results.

GIVEN

- A steel 12 in. I-beam
- Temperature of the top (T_L) = 260°C
- Temperature of the bottom (T_B) = 93°C
- Thickness of the web (t) = 1.25 cm
- Air temperature (T_∞) = 260°C
- Heat transfer coefficient (\bar{h}_c) = 40 W/(m² K)
- Thermal conductivity of the steel (k) = 43 W/(m K)

FIND

- The temperature distribution along the web and the plot the results

ASSUMPTIONS

- The thermal conductivity of the steel is uniform
- The beam has reached steady state conditions
- One dimensional through the web
- The beam is very long compared to the web thickness

SKETCH

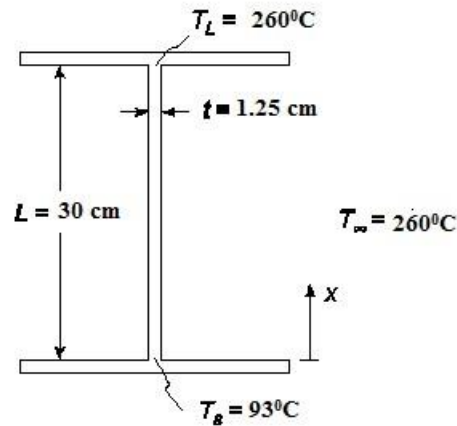

SOLUTION

The web of the I beam can be thought of as a fin with a uniform rectangular cross section and a fixed tip temperature. From Table 2.1, the temperature distribution along the web is

$$\frac{\theta}{\theta_s} = \frac{\left(\frac{\theta}{T}\right) \sinh(mx) + \sinh[m(L-x)]}{\sinh(mL)}$$

where

$$\theta = T - T_\infty$$

$$m = \sqrt{\frac{\bar{h}_c P}{kA}} = \sqrt{\frac{\bar{h}_c 2(w+t)}{kwt}} = \sqrt{\frac{2\bar{h}_c}{kt}} = \sqrt{\frac{2(40 \text{ W}/(\text{m}^2\text{K}))}{43 \text{ W}/(\text{m K})(0.0125\text{m})}} = 12.2 \frac{1}{\text{m}}$$

$$mL = 3.666 \text{ \& } \sinh(mL) = 19.54$$

$$\theta_s = T_s - T_\infty = 93^\circ\text{C} - 260^\circ\text{C} = -167^\circ\text{C}$$

$$\theta_L = T_L - T_\infty = 0$$

Substitute these into the temperature distribution

$$\frac{T(x) - T_\infty}{\theta_s} = 0.0512 \sinh [3.666 (1 - x)]$$

$$T_{(x)} = 260^\circ\text{C} - 15.353 \sinh [3.66 (1 - x)]$$

This temperature distribution is plotted below

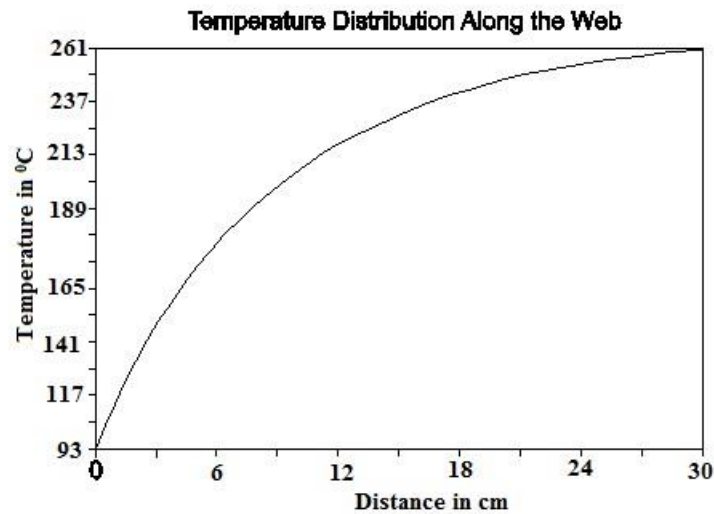

COMMENTS

In a real situation, the heat transfer coefficient is likely to vary with distance and this would require a numerical solution.

PROBLEM 2.48

The handle of a ladle used for pouring molten lead is 30-cm-long. Originally the handle was made of 1.9×1.25 cm mild steel bar stock. To reduce the grip temperature, it is proposed to form the handle of tubing 0.15-cm-thick with the same rectangular shape. If the average heat transfer coefficient over the handle surface is $14 \text{ W}/(\text{m}^2 \text{ K})$, estimate the reduction of the temperature at the grip in air at 21°C .

GIVEN

- A steel handle of a ladle used for pouring molten lead
- Handle length (L) = 30 cm = 0.3 m
- Original handle: 1.9 by 1.25 cm mild steel bar stock
- New handle: tubing 0.15 cm thick with the same shape
- The average heat transfer coefficient (\bar{h}_c) = $14 \text{ W}/(\text{m}^2 \text{ K})$
- Air temperature (T_∞) = 21°C

FIND

- The reduction of the temperature at the grip

ASSUMPTIONS

- The lead is at the melting temperature
- The handle is made of 1% carbon steel
- The ladle is normally in steady state during use
- The variation of the thermal conductivity is negligible
- One dimensional conduction
- Heat transfer from the end of the handle can be neglected

SKETCH

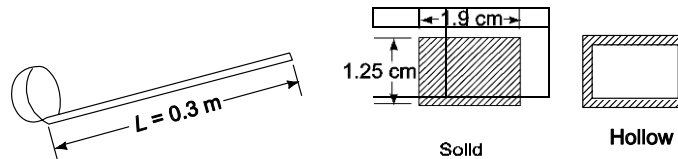

PROPERTIES

From Appendix 2, Tables 10 and 12

Thermal conductivity of 1% carbon steel = $43 \text{ W}/(\text{m K})$ at 20°C

Melting temperature of lead (T_s) = $601 \text{ K} = 328^\circ\text{C}$

SOLUTION

The ladle handle can be treated as a fin with an adiabatic end as shown below

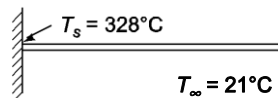

The temperature distribution in the handle, from Table 2.1 is

$$\frac{\theta}{\theta_s} = \frac{\cosh[m(L-x)]}{\cosh(mL)}$$

where $\theta = T(x) - T_\infty$ $\theta_s = T_s - T_\infty = 328^\circ\text{C} - 21^\circ\text{C} = 307^\circ\text{C}$

$$m = \sqrt{\frac{\bar{h}_c P}{kA}}$$

where

$$P = 2w + 2t = 2(0.019 \text{ m}) + 2(0.0125 \text{ m}) = 0.063 \text{ m}$$

The only difference in the two handles is the cross-sectional area

Solid handle

$$A_s = wt = (0.019 \text{ m})(0.0125 \text{ m}) = 0.0002375 \text{ m}^2$$

$$mL = 0.3 \text{ m} \sqrt{\frac{14 \text{ W}/(\text{m}^2 \text{ K})(0.063 \text{ m})}{43 \text{ W}/(\text{m K})(0.0002375 \text{ m}^2)}} = 2.788$$

$$\frac{\theta_L}{\theta_s} = \frac{\cosh(0)}{\cosh(2.788)} = 0.1266 \Rightarrow \theta_L = T_L - T_\infty = 0.1226 \theta_s$$

$$\therefore T_L = T_\infty + 0.1266 \theta_s = 21^\circ\text{C} + 0.1266 (307^\circ\text{C}) = 60^\circ\text{C}$$

Hollow handle

$$A_H = wt - [w - 2(0.0015 \text{ m})][t - 2(0.0015 \text{ m})]$$

$$= (0.019 \text{ m})(0.0125 \text{ m}) - (0.016 \text{ m})(0.0095 \text{ m}) = 0.0000855 \text{ m}^2$$

$$mL = 0.3 \text{ m} \sqrt{\frac{14 \text{ W}/(\text{m}^2 \text{ K})(0.063 \text{ m})}{43 \text{ W}/(\text{m K})(0.0000855 \text{ m}^2)}} = 4.65$$

$$\frac{\theta_L}{\theta_s} = \frac{\cosh(0)}{\cosh(4.647)} = 0.0192$$

$$T_L = T_\infty + 0.01919 \theta_s = 21^\circ\text{C} + 0.0192 (307^\circ\text{C}) = 27^\circ\text{C}$$

The temperature of the grip is reduced 33°C by using the hollow handle.

COMMENTS

The temperature of the hollow handle would be comfortable to the bare hand. Therefore, no insulation is required. This will reduce the cost of the item without reducing utility.

PROBLEM 2.49

A 0.3-cm-thick aluminum plate has rectangular fins 0.16×0.6 cm, on one side, spaced 0.6 cm apart. The finned side is in contact with low pressure air at 38°C and the average heat transfer coefficient is $28.4 \text{ W}/(\text{m}^2 \text{ K})$. On the unfinned side water flows at 93°C and the heat transfer coefficient is $284 \text{ W}/(\text{m}^2 \text{ K})$. (a) Calculate the efficiency of the fins (b) calculate the rate of heat transfer per unit area of wall and (c) comment on the design if the water and air were interchanged.

GIVEN

- Aluminum plate with rectangular fins on one side
- Plate thickness (D) = 0.3 cm = 0.003 m
- Fin dimensions ($t \times L$) = 0.0016 m \times 0.006 m
- Fin spacing (s) = 0.006 m apart
- Finned side
 - Air temperature (T_a) = 38°C
 - Heat transfer coefficient (\bar{h}_a) = $28.4 \text{ W}/(\text{m}^2 \text{ K})$
- Unfinned side
 - Water temperature (T_w) = 93°C
 - Heat transfer coefficient (\bar{h}_w) = $284 \text{ W}/(\text{m}^2 \text{ K})$

FIND

- The fin efficiency (η_f)
- Rate of heat transfer per unit wall area (q/A_w)
- Comment on the design if the water and air were interchanged

ASSUMPTIONS

- Width of fins is much longer than their thickness
- The system has reached steady state
- The thermal conductivity of the aluminum is constant

SKETCH

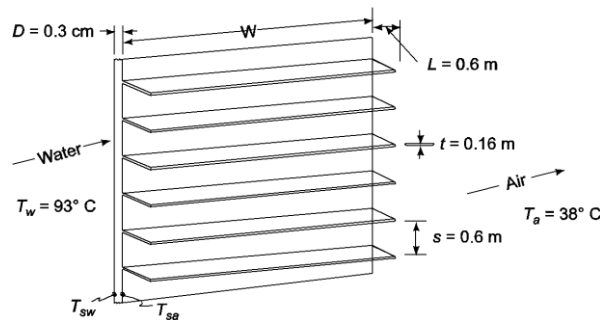

PROPERTIES AND CONSTANTS

From Appendix 2, Table 12

The thermal conductivity of aluminum (k) = $238 \text{ W}/(\text{m K})$ at 65°C

SOLUTION

- The fin efficiency is defined as the actual heat transfer rate divided by the rate of heat transfer if the entire fin were at the wall temperature. Since the fin is of uniform cross section, Table 2.1 can be used to find an expression for the heat transfer from a fin with a convection from the tip

$$q_f = M \frac{\sinh(mL) + \frac{\bar{h}_a}{mk} \cosh(mL)}{\cosh(mL) + (\bar{h}_a/mk) \sinh(mL)}$$

where

$$m^2 = \frac{\bar{h}_a P}{kA} = \frac{\bar{h}_a 2w}{k(wt)} = \frac{2\bar{h}_a}{kt}$$

$$M = \sqrt{\bar{h}_a P k A} \theta_s = w \sqrt{2\bar{h}_a t k} \theta_s$$

where

$$\theta_s = T_{sa} - T_a$$

If the entire fin were at the wall temperature (T_{sa}) the rate of heat transfer would be

$$q'_f = \bar{h}_a A_f (T_{sa} - T_a) = \bar{h}_a w(2L + t) (T_{sa} - T_a)$$

The fin efficiency is $\eta_f = \frac{q_f}{q'_f} = \frac{M \frac{\sinh(mL) + \frac{\bar{h}_a}{mk} \cosh(mL)}{\cosh(mL) + (\bar{h}_a/mk) \sinh(mL)}}{\bar{h}_a w(2L + t) (T_{sa} - T_a)}$

$$m = \sqrt{\frac{2\bar{h}_a}{kt}} = \sqrt{\frac{2 \cdot 28.4 \text{ W/(m}^2 \text{ K)}}{238 \text{ W/(m K)}(0.0016 \text{ m)}}} = 12.2 \frac{1}{\text{m}}$$

$$mL = 12.2 \frac{1}{\text{m}} (0.006 \text{ m}) = 0.0733$$

$$M = w (T_{sa} - T_a) \sqrt{2 \cdot 28.4 \text{ W/(m}^2 \text{ K)} (0.0016 \text{ m}) \cdot 238 \text{ W/(m}^2 \text{ K)}} = 4.65 w (T_{sa} - T_w) \text{ W/(mK)}$$

$$\bar{h}_a = \frac{28.4 \text{ W/(m}^2 \text{ K)}}{0.0098} = 0.0098$$

$$mk = 12.2 \frac{1}{\text{m}} \cdot 238 \text{ W/(m K)} = 0.00977$$

$$\eta_f = \frac{4.65 \text{ W/(m}^2 \text{ K)} \left(\frac{\sinh(0.0733) + \cosh(0.0733)}{\cosh(0.0733) + 0.00977 \sinh(0.0733)} \right)}{28.4 \text{ W/(m}^2 \text{ K)} [(2)(0.006 \text{ m}) + 0.0016 \text{ m}]} = 0.998$$

(b) The heat transfer to the air is equal to the sum of heat transfer from the fins and the heat transfer from the wall area not covered by fins.

The number of fins per meter height is

$$1 \text{ m} / (0.076 \text{ m/fin}) = 131.6 \text{ fins}$$

The wall area not covered by fins per m^2 of total wall area is

$$A_{\text{bare}} = 1 \text{ m}^2 - (131.6 \text{ fins}) (0.0016 \text{ m/fin}) (1 \text{ m width}) = 0.789 \text{ m}^2$$

The surface area of the fins per m^2 of wall area is

$$A_{\text{fins}} = 131.6 \text{ fins} (2(0.006 \text{ m}) + 0.0016 \text{ m}) (1 \text{ m width}) = 1.79 \text{ m}^2$$

The rate of heat transfer to the air is

$$q_a = \bar{h}_a A_{\text{bare}} (T_{sa} - T_a) + \bar{h}_a \eta_f A_{\text{fins}} (T_{sa} - T_a)$$
$$q_a = \bar{h}_a (A_{\text{bare}} + \eta_f A_{\text{fins}}) (T_{sa} - T_a) = \frac{T_{sa} - T_a}{R_{ca}}$$

Therefore, the resistance to heat transfer on the air side (R_a) is

$$R_{ca} = \frac{1}{\bar{h}_a(A_{\text{bare}} + \eta_f A_{\text{fins}})} \approx \frac{1}{h_a A_{\text{total}}}$$

The thermal circuit for the wall is shown below

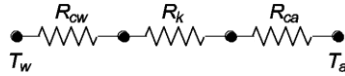

The individual resistance based on 1 m² of wall area are

$$R_{cw} = \frac{1}{h_w A_w} = \frac{1}{238.7 \text{ W}/(\text{m}^2 \text{ K})(1 \text{ m}^2)} = 0.00419 \text{ K/W}$$

$$R_k = \frac{D}{k A_w} = \frac{0.003 \text{ m}}{238.7 \text{ W}/\text{m K}(1 \text{ m}^2)} = 0.0000126 \text{ K/W}$$

$$R_{ca} = \frac{1}{h_a(A_{\text{bare}} + \eta_f A_{\text{fins}})} = \frac{0.003 \text{ m}}{28.4 \text{ W}/(\text{m}^2 \text{ K}) [0.789 + (0.998)(1.79 \text{ m}^2)]} = 0.0137 \text{ K/W}$$

The rate of heat transfer through the wall is

$$q = \frac{\Delta T}{R_{\text{tot}}} = \frac{T_w - T_a}{R_{cw} + R_k + R_{ca}} = \frac{93^\circ\text{C} - 38^\circ\text{C}}{(0.00419 + 0.0000126 + 0.0137) \text{ K/W}} = 3072 \text{ W (per m}^2 \text{ of wall)}$$

(c) Note that the air side convective resistance is by far the dominant resistance in the problem. Therefore, the fins will enhance the overall heat transfer much less on the water side.

For fins on the water side

$$m = \sqrt{\frac{2 \cdot 283.7 \text{ W}/(\text{m}^2 \text{ K})}{238 \text{ W}/(\text{m K})(0.0016 \text{ m})}} = 38.6 \frac{1}{\text{m}} \text{ and } mL = 38.6 \frac{1}{\text{m}} (0.006 \text{ m}) = 0.2316$$

$$M = w (T_{sw} - T_w) \sqrt{2 \cdot 283.7 \text{ W}/(\text{m}^2 \text{ K}) (0.0016 \text{ m})^2 \cdot 238 \text{ W}/(\text{m K})} = 14.70 w (T_{sw} - T_w) \text{ W/m K}$$

$$\frac{\bar{h}_w}{m} = \frac{283.7 \text{ W}/(\text{m}^2 \text{ K})}{38.6 \frac{1}{\text{m}}} = 0.0309$$

$$mk = 38.6 \frac{1}{\text{m}} \cdot 238 \text{ W}/(\text{m K})$$

$$\eta_f = \frac{14.70 \text{ W}/(\text{m K}) \left[\frac{\sinh(0.2316) + 0.0309 \cosh(0.2316)}{\cosh(0.2316) + 0.0309 \sinh(0.2316)} \right]}{283.7 \text{ W}/(\text{m}^2 \text{ K}) [2(0.006 \text{ m}) + 0.0016 \text{ m}]} = 0.978$$

$$\frac{T_w}{1.79} + \frac{93^\circ\text{C} - 38^\circ\text{C}}{+}$$

$$q = \frac{1}{\frac{1}{h_{ca}} + \frac{D}{k} + \frac{1}{h_{cw}(0.089 + \eta)}} = (0.0352 + 0.0000126 + 0.00139) \text{ } ^2\text{K)/W}$$

$$= 1502 \text{ W/m}^2$$

COMMENTS

The fins are most effective in the medium with the lowest heat transfer coefficient.

With no fins, the rate of heat transfer would be 1419 W/m². Fins on the water side increase the rate of heat transfer 6%. Fins on the air side increase the rate of heat transfer 116%. Therefore, installing fins on the water side would be a poor design.

MULTIDIMENSIONAL STEADY STATE CONDUCTION

PROBLEM 2.50

Compare the rate of heat flow from the bottom to the top in the aluminum structure shown in the sketch below with the rate of heat flow through a solid slab. The top is at -10°C , the bottom at 0°C . The holes are filled with insulation which does not conduct heat appreciably.

GIVEN

- The aluminum structure shown in the sketch below
- Temperature of the top (T_T) = -10°C
- Temperature of the bottom (T_B) = 0°C
- The holes are filled with insulation which does not conduct heat appreciably

FIND

- Compare the rate of heat flow from the bottom to the top with the rate of heat flow through a solid slab

ASSUMPTIONS

- The structure is in steady state
- Heat transfer through the insulation is negligible
- The thermal conductivity of the aluminum is uniform
- The edges of the structure are insulated
- Two dimensional conduction through the structure

SKETCH

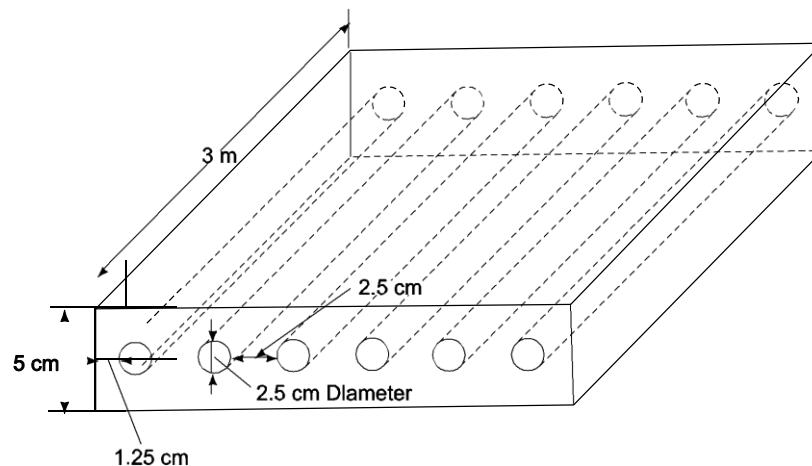

PROPERTIES AND CONSTANTS

The thermal conductivity of aluminum (k) = $236 \text{ W}/(\text{m K})$ at 0°C

SOLUTION

Because of the symmetry of the structure, we can draw the flux plot for just one of the twenty-four equivalent sections

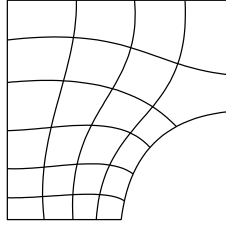

- (a) The total number of flow lanes in the structure, $(M) = (12) (4) = (48)$. Each flow lane consists of 12 curvilinear squares (6 on top as shown, and 6 on bottom. Therefore, the shape factor is

$$S = \frac{M}{N} = \frac{48}{12} = 4$$

The heat flow per meter, from Equation (2.85), is

$$q = k\Delta T_{\text{overall}} = 236 \text{ W/m K} (4) (0^\circ\text{C} - (-10^\circ\text{C})) = 9440 \text{ W/m}$$

The total rate of heat flow is

$$q_{\text{TOT}} = q (\text{length of structure}) = 9440 \text{ W/m} (3 \text{ m}) = 28,320 \text{ W}$$

- (b) For a solid aluminum plate, the total heat flow from Equation (1.3), is

$$q_{\text{TOT}} = \frac{Ak}{t} \Delta T = \frac{(3\text{m})(0.3\text{m}) 236 \text{ W/(m K)}}{0.05} (10 \text{ C}) = 42,500 \text{ W}$$

Therefore, the insulation filled tubes reduce the heat transfer rate by 33%.

COMMENTS

The shape factor was determined graphically and can easily be in error by 10%.

Also, the surface temperature will not be uniform in the insulated structure.

PROBLEM 2.51

Determine by means of a flux plot the temperatures and heat flow per unit depth in the ribbed insulation shown in the accompanying sketch.

GIVEN

- The sketch below

FIND

- The temperatures
- The heat flow per unit depth

ASSUMPTIONS

- Steady state conditions
- Two dimensional heat flow
- The heat loss through the insulation is negligible
- The thermal conductivity of the material is uniform

SKETCH

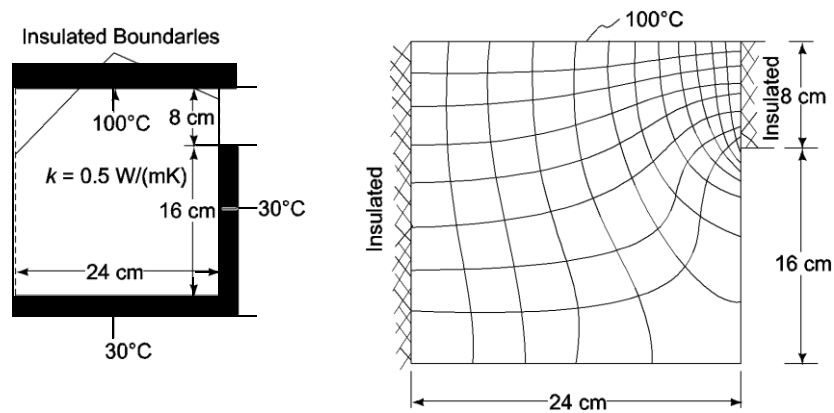

SOLUTION

The total number of heat flow lanes (M) = 11

The number of curvilinear squares per lane (N) = 8

Therefore, the shape factor is

$$S = \frac{M}{N} = \frac{11}{8} = 1.38$$

The rate of heat transfer for unit depth is given by Equation 2.85

$$q = kS\Delta T = (0.5 \text{ W/(m K)}) (1.38) (100^\circ\text{C} - 30^\circ\text{C}) = 48.3 \text{ W/m}$$

PROBLEM 2.52

Use a flux plot to estimate the rate of heat flow through the object shown in the sketch. The thermal conductivity of the material is 15 W/(m K) . Assume no heat is lost from the sides.

GIVEN

The shape of object shown in the sketch
The thermal conductivity of the material (k) = 15 W/(m K)
The temperatures at the upper and lower surfaces (30°C & 10°C)

FIND

The rate of heat flow through the object (By means of a flux plot)

ASSUMPTIONS

No heat is lost from the sides and ends
Uniform thermal conductivity
Two dimensional conduction
Steady state

SKETCH

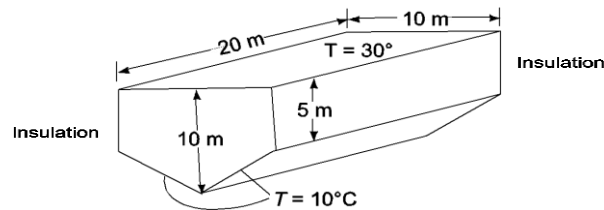

SOLUTION

The flux plot is shown below

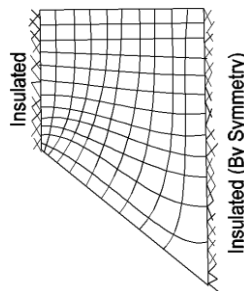

The number of heat flow lanes (M) = $2 \times 10 = 20$

The number of curvilinear squares in each lane (N) = 12

Therefore, the shape factor for this object is

$$S = M/N = 20/12 = 1.67$$

The rate of heat transfer per unit length from Equation (2.85) is

$$q = kS\Delta T_{\text{overall}} = [15 \text{ W/(m K)}] (1.67) (20^\circ\text{C}) = 500 \text{ W/m}$$

The total rate of heat transfer is

$$q_{\text{tot}} = qL = (500 \text{ W/m}) (20 \text{ m}) = 10,000 \text{ W}$$

PROBLEM 2.53

Determine the rate of heat transfer per unit length from a 5-cm-OD pipe at 150°C placed eccentrically within a larger cylinder of 85% Magnesia wool as shown in the sketch. The outside diameter of the larger cylinder is 15 cm and the surface temperature is 50°C.

GIVEN

- A pipe placed eccentrically within a larger cylinder of 85% Magnesia wool as shown in the sketch
- Outside diameter of the pipe (D_p) = 5 cm = 0.05 m
- Temperature of the pipe (T_s) = 150°C
- Outside diameter of the larger cylinder (D_o) = 15 cm = 0.15 m
- Temperature of outer pipe (T_o) = 50°C

FIND

- The rate of heat transfer per meter length (q)

ASSUMPTIONS

- Two dimensional heat flow (no end effects)
- The system is in steady state
- Uniform thermal conductivity

SKETCH

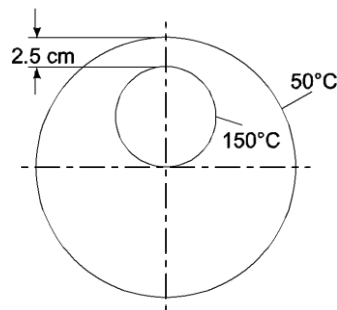

PROPERTIES AND CONSTANTS

From Appendix 2, Table 11

The thermal conductivity of 85% Magnesia wool (k) = 0.059 W/(m K) (at 20°C).

SOLUTION

The rate of heat transfer can be estimated from a flux plot

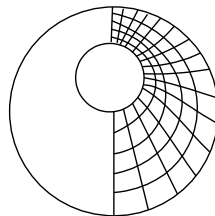

The number of flow lanes (M) = $2 \times 15 = 30$

The number of squares per lane (N) = 5

Therefore, the shape factor is

$$S = \frac{M}{N} = \frac{30}{5} = 6$$

Equation (2.85) can be used to find the rate of heat transfer per unit length

$$q = kS\Delta T = kS(T_s - T_o) = [0.059 \text{ W/(m K)}] (6) (150^\circ\text{C} - 50^\circ\text{C}) = 35.4 \text{ W/m}$$

COMMENTS

This problem can also be solved analytically (see Table 2.2)

$$S = \frac{2\pi}{\cosh^{-1}\left(\frac{D^2 + d - 4z^2}{2Dd}\right)} = 6.53$$

(z = the distance between the centers of the circular cross sections)

$$\therefore q = kS\Delta T = 38.5 \text{ W/m}$$

The answer from the graphical solution is 8% less than the analytical value.

PROBLEM 2.54

Determine the rate of heat flow per foot length from the inner to the outer surface of the molded insulation in the accompanying sketch. Use $k = 0.17 \text{ W/(m K)}$.

GIVEN

The object with a cross section as shown in the sketch below
 The thermal conductivity (k) = 0.17 W/(m K)

FIND

The rate of heat flow per foot length from the inner to the outer surface (q)

ASSUMPTIONS

The system has reached steady state
 The thermal conductivity does not vary with temperature
 Two dimensional conduction

SKETCH

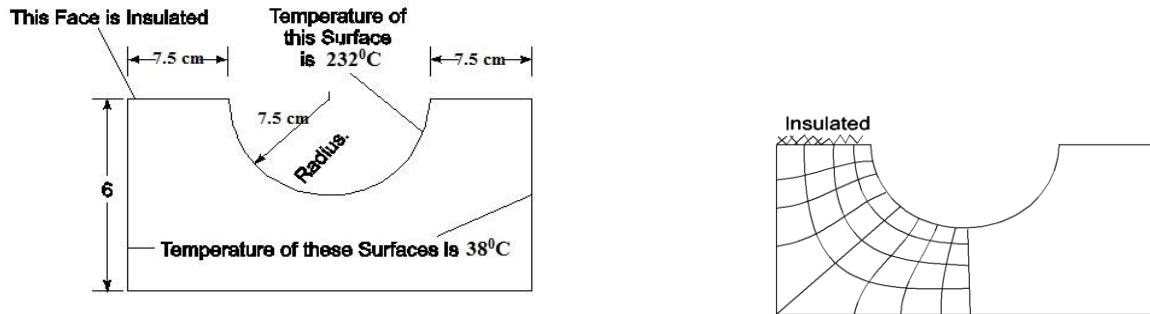

SOLUTION

A flux plot for the object is shown below

The number of heat flow lanes (M) = $2 \times 8 = 16$

The number of curvilinear squares per lane (N) = 4

Therefore, the shape factor is $S = \frac{16}{4} = 4$

The heat flow per unit length, from Equation (2.85) is

$$q = kS\Delta T_{\text{overall}} = [0.17 \text{ W/(m K)}] (4) (194^\circ\text{C}) = 132 \text{ W/m}$$

COMMENTS

The problem can also be solved analytically. From Table 2.2

$$S = \frac{\pi}{\ln 1.08 W/D} = \frac{\pi}{\ln 1.08 \frac{12}{6}} = 4.08$$

$$q = kS\Delta T = 134.5 \text{ W/m}$$

The analytical solution yields a rate of heat flow that is about 2% larger than the value obtained from the flux plot.

PROBLEM 2.55

A long 1-cm-diameter electric copper cable is embedded in the center of a 25 cm square concrete block. If the outside temperature of the concrete is 25°C and the rate of electrical energy dissipation in the cable is 150 W per meter length, determine the temperatures at the outer surface and at the center of the cable.

GIVEN

- A long electric copper cable embedded in the center of a square concrete block
- Diameter of the pipe (D_p) = 1 cm = 0.01 m
- Length of a side of the block = 25 cm = 0.25 m
- The outside temperature of the concrete (T_o) = 25°C
- The rate of electrical energy dissipation (\dot{Q}_G/L) = 150 W/m

FIND

- The temperatures at the outer surface (T_s) and at the center of the cable (T_c)

ASSUMPTIONS

- Two dimensional, steady state heat transfer
- Uniform thermal conductivities

SKETCH

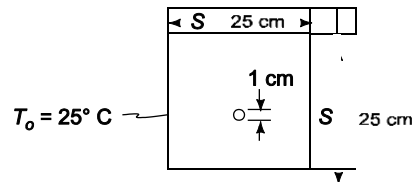

PROPERTIES AND CONSTANTS

From Appendix 2, Table 11

The thermal conductivity of concrete (k_b) = 0.128 W/(m K) at 20°C

From Appendix 2, Table 12

The thermal conductivity of copper (k_c) = 396 W/(m K) at 63°C

SOLUTION

For steady state, the rate of heat transfer through the concrete block must equal the rate of electrical energy dissipation. The heat transfer rate can be estimated with a flux plot of one quarter of the block:

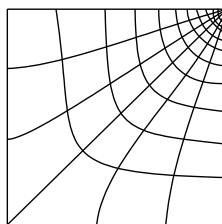

The number of flow lanes (M) = $4 \times 6 = 24$

The number of squares per lane (N) = 10

Therefore, the shape factor is

$$S = \frac{M}{N} = \frac{24}{10} = 2.4$$

The rate of heat flow per unit length is given by Equation (2.85)

$$q = k_b S \Delta T = k_b S (T_s - T_o) = \frac{Q_G}{L}$$

Solving for the surface temperature of the cable

$$T_s = T_o + \frac{\left(\frac{Q_G}{L}\right)}{k_b S} = 25^\circ\text{C} + \frac{150\text{W/m}}{[0.128\text{W}/(\text{m K})](2.4)} = 513^\circ\text{C}$$

From Equation (2.56) the temperature in the center of the cable is

$$T_c = T_s + \frac{\dot{q}_G r_0^2}{4k_C}$$

Where \dot{q}_G = heat generation per unit volume $\frac{\dot{q}_G}{\pi r_0^2 L}$

$$T_c = T_s + \frac{\left(\frac{\dot{q}_G}{\pi r_0^2 L}\right)}{4\pi k_C} = 513^\circ\text{C} + \frac{150\text{W/m}}{4\pi \cdot 396\text{W}/(\text{m K})} = 513^\circ\text{C} + 0.03^\circ\text{C} \approx 513^\circ\text{C}$$

COMMENT

The thermal conductivity of the cable is quite large and therefore its temperature is essentially uniform. The analytical solution for this geometry, given in Table 2.2, is

$$S = \frac{2\pi}{\ln \frac{W}{D}} = \frac{2\pi}{\ln \left(1.08 \frac{25 \text{ cm}}{1 \text{ cm}}\right)} = 1.91$$

This would lead to a cable temperature of 639°C, 20% higher than the flux plot estimate. The high error is probably due to the difficulty in drawing the flux plot close to the cable and may be improved by drawing a larger scale flux plot is geometries that involve tight curves.

PROBLEM 2.56

A large number of 3.8 cm *OD* pipes carrying hot and cold liquids are embedded in concrete in an equilateral staggered arrangement with center line 11.2 cm apart as shown in the sketch. If the pipes in rows A and C are at 16°C while the pipes in rows B and D are at 66°C, determine the rate of heat transfer per foot length from pipe *X* in row B.

GIVEN

- A large number of pipes embedded in concrete as shown below
- Outside diameter of pipes (*D*) = 3.8 cm
- The temperature of the pipes in rows A and C = 16°C
- The temperature of the pipes in rows B and D = 66°C

FIND

- The rate of heat transfer per foot length from pipe *X* in row B

ASSUMPTIONS

- Steady state, two dimensional heat transfer
- Uniform thermal conductivity in the concrete

SKETCH

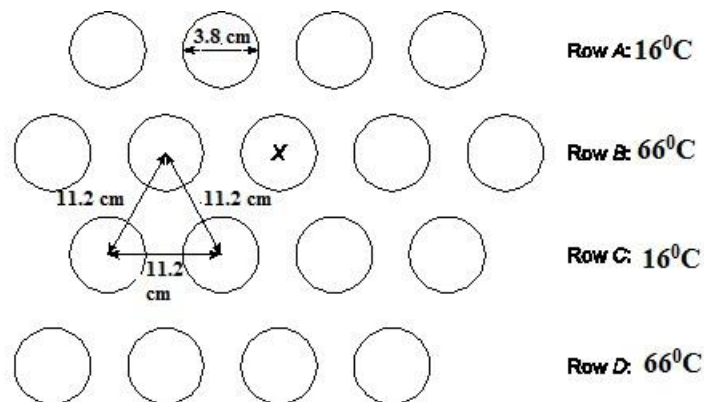

PROPERTIES AND CONSTANTS

From Appendix 2, Table 11

The thermal conductivity of concrete (k_b) = 0.128 W/(m K) at 20°C

SOLUTION

A flux diagram for this problem is shown below

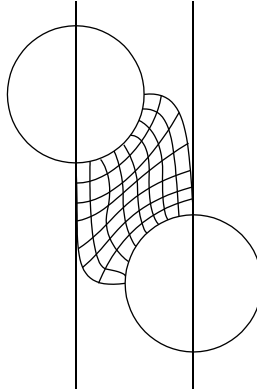

By symmetry, the total heat transfer from the tube X is four times that shown in the flux diagram.

The number of heat flow lanes (M) = $8 \times 4 = 32$

The number of curvilinear squares per lane (N) = 7

Therefore, the shape factor is

$$S = \frac{M}{N} = \frac{32}{7} = 4.6$$

The heat transfer per unit length from Table 2.2, from Equation (2.85) is

$$q KS\Delta T_{\text{overall}} = [0.128 \text{ W/(m K)}] (4.6) (66^{\circ}\text{C} - 16^{\circ}\text{C}) = 29.44 \text{ W/m}$$

PROBLEM 2.57

A long 1-cm-diameter electric cable is imbedded in a concrete wall ($k = 0.13 \text{ W/(m K)}$) which is $1 \text{ m} \times 1 \text{ m}$, as shown in the sketch. If the lower surface is insulated, the surface of the cable is 100°C and the exposed surface of the concrete is 25°C , estimate the rate of energy dissipation per meter of cable.

GIVEN

A long electric cable imbedded in a concrete wall with cable diameter (D) = 1 cm = 0.01 m

Thermal conductivity of the wall (k) = 0.13 W/(m K)

Wall dimensions are 1 m by 1 m, as shown in the sketch below

The lower surface is insulated

The surface temperature of the cable (T_s) = 100°C

The temperature of the exposed concrete surfaces (T_o) = 25°C

FIND

The rate of energy dissipation per meter of cable (q/L)

ASSUMPTIONS

The system is in steady state

The thermal conductivity of the wall is uniform

Two dimensional heat transfer

SKETCH

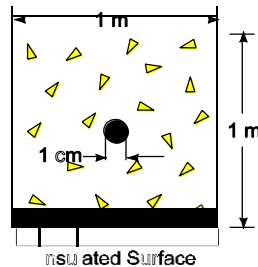

SOLUTION

By symmetry, only half of the flux plot needs to be drawn

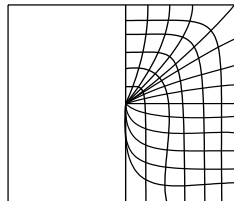

The number of heat flow lanes (M) = $2 \times 14 = 28$

The number of curvilinear squares per lane (N) = 6

Therefore, the shape factor is

$$S = M/N = 28/6 = 4.7$$

For steady state, the rate of energy dissipation per unit length in the cable must equal the rate of heat transfer per unit length from the cable which, from Equation (2.85), is

$$q = kS(T_s - T_o) = (0.13 \text{ W/(m K)}) (4.7) (100^\circ\text{C} - 25^\circ\text{C}) = 46 \text{ W/m}$$

Determine the temperature distribution and heat flow rate per meter length in a long concrete block having the shape shown below. The cross-sectional area of the block is square and the hole is centered.

GIVEN

- A long concrete block having the shape shown below
- The cross-sectional area of the block is square
- The hole is centered

FIND

- (a) The temperature distribution in the block
- (b) The heat flow rate per meter length

ASSUMPTIONS

- The heat flow is two dimensional and in steady state
- The thermal conductivity in the block is uniform

SKETCH

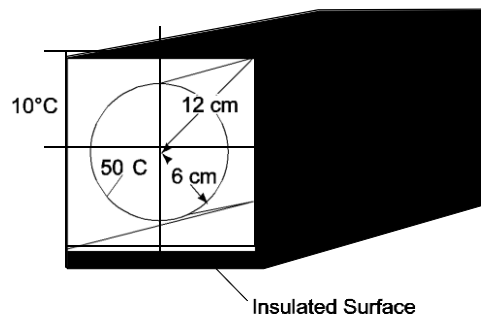

PROPERTIES AND CONSTANTS

From Appendix 2, Table 11

The thermal conductivity of concrete (k_b) = 0.128 W/(m K) at 20°C

SOLUTION

The temperature distribution and heat flow rate may be estimated with a flux plot

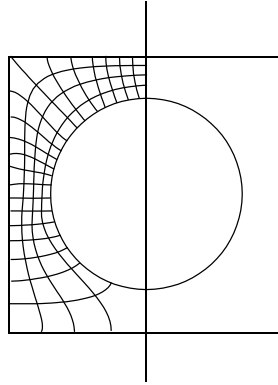

- (a) The temperature distribution is given by the isotherms in the flux plot.
 (b) The number of flow lanes (M) = $2 \times 21 = 42$
 The number of squares per lane (N) = 4
 Therefore, the shape factor is

$$S = \frac{M}{N} = \frac{42}{4} = 10.5$$

From Equation (2.85), the rate of heat flow per unit length is

$$q = kS\Delta T = [0.128 \text{ W/(m K)}] (10.5) (40^\circ\text{C}) = 54 \text{ W/m}$$

COMMENTS

If the lower surface were not insulated, the shape factor from Table 2.2, would be

$$S = \frac{2\pi}{\ln 1.08 \frac{W}{D}} = 14.8 \Rightarrow q = 75.6 \text{ W/m}$$

The rate of heat transfer with the insulation as calculated with the flux plot is about 29% less than the analytical result without insulation. We would expect a reduction of slightly less than 25%.

PROBLEM 2.59

A 30-cm-OD pipe with a surface temperature of 90°C carries steam over a distance of 100 m. The pipe is buried with its center line at a depth of 1 m, the ground surface is -6°C , and the mean thermal conductivity of the soil is $0.7\text{ W}/(\text{m K})$. Calculate the heat loss per day, and the cost of this loss if steam heat is worth $\$3.00$ per 10^6 kJ . Also, estimate the thickness of 85% magnesia insulation necessary to achieve the same insulation as provided by the soil with a total heat transfer coefficient of $23\text{ W}/(\text{m}^2\text{ K})$ on the outside of the pipe.

GIVEN

- A buried steam pipe
- Outside diameter of the pipe (D) = 30 cm = 0.3 m
- Surface temperature (T_s) = 90°C
- Length of pipe (L) = 100 m
- Depth of its center line (Z) = 1 m
- The ground surface temperature (T_g) = -6°C
- The mean thermal conductivity of the soil (k) = $0.7\text{ W}/(\text{m K})$
- Steam heat is worth $\$3.00$ per 10^6 kJ
- The heat transfer coefficient (h_c) = $23\text{ W}/(\text{m}^2\text{ K})$ for the insulated pipe

FIND

- The heat loss per 24 hour day
- The value of the lost heat
- The thickness of 85% magnesia insulation necessary to achieve the same insulation

ASSUMPTIONS

- Steady state conditions
- Uniform thermal conductivity
- Two dimensional heat transfer from the pipe

SKETCH

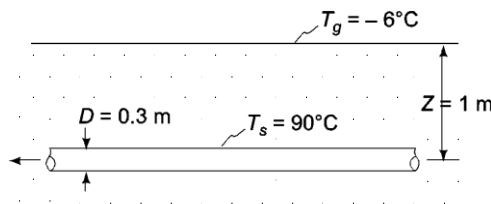

PROPERTIES AND CONSTANTS

From Appendix 2, Table 11

The thermal conductivity of 85% magnesia (k_i) = $0.059\text{ W}/(\text{m K})$ (at 20°C)

SOLUTION

- The shape factor for this problem, from Table 2.2, is

$$S = \frac{2\pi L}{\cosh^{-1}\left(\frac{2z}{D}\right)} \text{ If } z/L < 1$$

Note that the condition $Z/L \ll 1$ is satisfied in this problem.

$$S = \frac{2\pi(100\text{m})}{\cosh^{-1}\left(\frac{2(1\text{m})}{0.3\text{m}}\right)} = 243 \text{ m}$$

From Equation (2.85), the rate of heat transfer is

$$q = kS\Delta T = 0.7 \text{ W/(m K)} (243 \text{ m}) (90^\circ\text{C} - (-6^\circ\text{C}))$$

$$q = 16,300 \text{ W (J/Ws)} \left(\frac{\text{kJ}}{1000\text{J}}\right) \left(\frac{3600\text{s}}{\text{h}}\right) \left(\frac{24\text{h}}{\text{day}}\right) = 1.41 \times 10^6 \text{ kJ/Day}$$

(b) The cost of this heat loss is

$$\text{Cost} = 1.41 \times 10^6 \text{ kJ/day} \left(\frac{\$3.00}{10^6 \text{ kJ}}\right) = \$4.23/\text{day}$$

(c) The thermal circuit for the pipe covered with insulation is

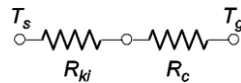

The rate of heat loss from the pipe is

$$q = \frac{T_s - T_g}{R_{ki} + R_c} = \frac{T_s - T_g}{\frac{1}{2\pi L k_i} \ln\left(\frac{r_o}{r_i} + \frac{1}{2\pi L r_o h_c}\right)} = 16,300 \text{ W}$$

$$16,300 \text{ W} = \frac{2\pi L(T_s - T_g)}{\frac{1}{k_i} \ln\left(\frac{r_o}{r_i} + \frac{1}{r_o h_c}\right)} = \frac{2\pi L(100\text{m})[90^\circ\text{C} - (-6^\circ)]}{\frac{1}{0.059\text{W/(m K)}} \ln\left(\frac{r_o}{0.15\text{m}} + \frac{1}{r_o \cdot 23\text{W/(m}^2\text{K)}}\right)}$$

$$\ln \frac{r_o}{0.15} + 0.00257 \frac{1}{r_o} = 0.2183$$

By trial and error: $r_o = 0.184 \text{ m}$

Insulation thickness = $r_o - r_i = 0.184 \text{ m} - 0.15 \text{ m} = 0.034 \text{ m} = 3.4 \text{ cm}$

COMMENTS

The value of the heat loss per year is $365 \times \$4.23 = \1544 . Hence insulation will pay for itself quite rapidly.

PROBLEM 2.60

Two long pipes, one having a 10-cm-OD and a surface temperature of 300°C, the other having a 5-cm-OD and a surface temperature of 100°C, are buried deeply in dry sand with their centerlines 15 cm apart. Determine the rate of heat flow from the larger to the smaller pipe per meter length.

GIVEN

Two long pipes buried deeply in dry sand

Pipe 1

- Diameter (D_1) = 10 cm = 0.1 m,
- Surface temperature (T_1) = 300°C

Pipe 2

- Diameter (D_2) = 5 cm = 0.05 m,
- Surface temperature (T_2) = 100°C

Spacing between their centerlines (s) = 15 cm = 0.15 m

FIND

The rate of heat flow per meter length (q/L)

ASSUMPTIONS

The heat flow between the pipes is two dimensional

The system has reached steady state

The thermal conductivity of the sand is uniform

SKETCH

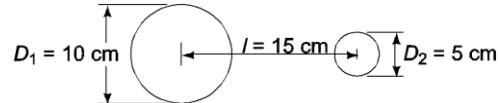

PROPERTIES AND CONSTANTS

From Appendix 2, Table 11

Thermal conductivity of dry sand (k) = 0.582 W/(m K) at 20°C

SOLUTION

The shape factor for this geometry, from Table 2.2, is

$$S = \frac{2\pi}{\cosh^{-1}\left(\frac{L^2 - 1 - r^2}{2r}\right)}$$

where

$$r = \frac{r_1}{r_2} = \frac{5 \text{ cm}}{2.5 \text{ cm}} = 2 \text{ and } L = \frac{L}{r_2} = \frac{15 \text{ cm}}{2.5 \text{ cm}} = 6$$

$$\therefore S = \frac{2\pi}{\cosh^{-1}\frac{36-1-4}{4}} = 2.296$$

The rate of heat transfer per unit length is

$$q = Sk\Delta T = (2.296) (0.582 \text{ W/(m K)}) (300^\circ\text{C} - 100^\circ\text{C}) = 267 \text{ W/m}$$

PROBLEM 2.61

A radioactive sample is to be stored in a protective box with 4-cm-thick walls having interior dimensions 4 cm* 4 cm* 12 cm. The radiation emitted by the sample is completely absorbed at the inner surface of the box, which is made of concrete. If the outside temperature of the box is 25°C, but the inside temperature is not to exceed 50°C, determine the maximum permissible radiation rate from the sample, in watts.

GIVEN

- A radioactive sample in a protective concrete box
- Wall thickness (t) = 4 cm = 0.4 m
- Box interior dimensions: 4 × 4 × 12 cm
- All radiation emitted is completely absorbed at the inner surface of the box
- The outside temperature of the box (T_o) = 25°C
- The maximum inside temperature (T_i) = 50°C

FIND

- The maximum permissible radiation rate from the sample, q (in watts)

ASSUMPTIONS

- The system is in steady state

SKETCH

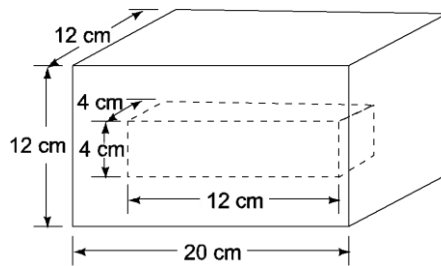

PROPERTIES AND CONSTANTS

From Appendix 2, Table 11

The thermal conductivity of concrete (k_b) = 0.128 W/(m K) at 20°C

SOLUTION

The box consists of

- 4 wall sections: $A = 4 \text{ cm} \times 12 \text{ cm}$
- 2 wall sections: $A = 4 \text{ cm} \times 4 \text{ cm}$
- 4 edge sections: $D = 12 \text{ cm}$ long
- 8 edge sections: $D = 4 \text{ cm}$ long
- 8 corner sections: $L = 4 \text{ cm}$ thick

The shape factors for this geometry (when all interior dimensions are greater than one-fifth of the wall thickness, as in this case) is given on Section 2.5.2 of the text

For the wall sections

$$S_1 = \frac{A}{L} = \frac{(4\text{cm})(12\text{cm})}{4\text{cm}} = 12 \text{ m} \quad \text{and} \quad S_2 = \frac{A}{L} = \frac{(4\text{cm})(4\text{cm})}{4\text{cm}} = 4 \text{ cm}$$

For the edge sections

$$S_3 = 0.54 D = 0.54 (12 \text{ cm}) = 6.48 \text{ cm} \quad \text{and} \quad S_4 = 0.54 D = 0.54 (4 \text{ cm}) = 2.16 \text{ cm}$$

For the corner sections

$$S_5 = 0.15 L = 0.15 (4 \text{ cm}) = 0.6 \text{ cm}$$

Multiplying each shape factor by the number of elements having that shape factor and summing them

$$S = 4 S_1 + 2 S_2 + 4 S_3 + 8 S_4 + 8 S_5$$

$$S = 4 (12 \text{ cm}) + 2(4 \text{ cm}) + 4(6.48 \text{ cm}) + 8(2.16 \text{ cm}) + 8(0.6 \text{ cm}) = 104 \text{ cm}$$

The rate of heat transfer is

$$q = kS\Delta T = 0.128 \text{ W}/(\text{m K}) (104 \text{ cm}) (1\text{m}/100 \text{ cm}) (50^\circ\text{C} - 25^\circ\text{C}) = 3.3 \text{ W}$$

COMMENTS

The conductivity of the concrete was evaluated at 20°C while the actual temperature is between 50°C and 25°C. Therefore, the actual rate of heat flow may be slightly different than that calculated, but no better property value is available in the text.

PROBLEM 2.62

A 15 cm-OD pipe is buried with its centerline 1.25 m below the surface of the ground [k of soil is 0.35 W/(m K)]. An oil having a density of 800 kg/m³ and a specific heat of 2.1 kJ/(kg K) flows in the pipe at 5.6 L/s. Assuming a ground surface temperature of 5°C and a pipe wall temperature of 95°C, estimate the length of pipe in which the oil temperature decreases by 5.5°C.

GIVEN

- An oil filled pipe buried below the surface of the ground
- Pipe outside diameter (D) = 15 cm = 0.15 m
- Depth of centerline (z) = 1.25 m
- Thermal conductivity of the soil (k) = 0.35 W/(m K)
- Specific gravity of oil (Sp. Gr.) = 0.8
- Specific heat of oil (c_p) = 2.1 kJ/(kg K)
- Flows rate of oil $\dot{m} = 5.6 \text{ L/s} = 0.0056 \text{ m}^3/\text{s}$
- The ground surface temperature (T_s) = 5°C
- The pipe wall temperature (T_p) = 95°C

FIND

- The length of pipe (L) in which the oil temperature decreases by 5.5°C

ASSUMPTIONS

- Steady state condition
- Two dimensional heat transfer

SKETCH

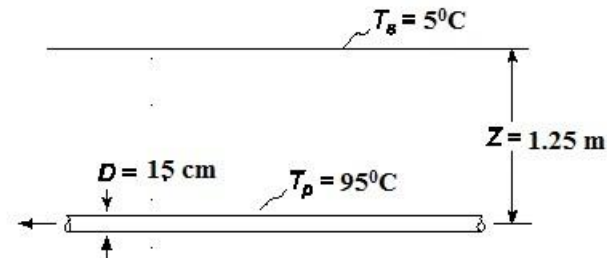

SOLUTION

The rate of heat flow from the pipe can be calculated using the shape factor from Table 2.2 for an infinitely long cylinder

$$S = \frac{2\pi}{\cosh^{-1} \frac{2Z}{D}} = \frac{2\pi}{\cosh^{-1} \left(\frac{2(1.25)}{0.15} \right)} = 1.79$$

The rate of heat transfer per unit length is given by Equation (2.85)

$$q = kS\Delta T_{\text{overall}} = (0.35 \text{ W/(m K)}) (1.79) (95^\circ\text{C} - 5^\circ\text{C}) = 56.4 \text{ W/m}$$

The total heat loss required to decrease the oil by 5.5°C is

$$q_t = \dot{m} c_p \Delta T = 0.0056 \text{ [m}^3\text{/s]} (2100 \text{ J/(kg K)}) (5.5^\circ\text{C}) * 800 \text{ (kg/m}^3) = 51744 \text{ W}$$

We can estimate the length of pipe in which the oil temperature drops 10°F by assuming the rate of heat loss from the pipe per unit length is constant, then:

$$q_t = qL \Rightarrow L = \frac{q_t}{q} = \frac{51744}{56.4} = 917.5 \text{ m}$$

COMMENTS

The heat loss from the pipe will actually be less because as the oil temperature and therefore also the pipe temperature decreases with distance from the inlet. This means the length will be slightly longer than the estimate above. If the calculation is based on an arithmetic mean pipe temperature of 50°C, the estimated length is 954 m about 4% more.

PROBLEM 2.63

A 2.5-cm-OD hot steam line at 100°C runs parallel to a 5.0-cm-OD cold water line at 15°C. The pipes are 5 cm center to center and deeply buried in concrete with a thermal conductivity of 0.87 W/(m K). What is the heat transfer per meter of pipe between the two pipes?

GIVEN

- Hot pipe outside diameter (D_h) = 2.5 cm = 0.025 m
- Hot pipe temperature (T_h) = 100°C
- Cold pipe outside diameter (D_c) = 5.0 cm = 0.05 m
- Cold pipe temperature (T_c) = 15°C
- Center to center distance between pipes (l) = 5 cm = 0.05 m
- Thermal conductivity of concrete (k) = 0.87 W/(m K)

FIND

- The heat transfer per meter of pipe (q/L)

ASSUMPTIONS

- Two dimensional heat transfer between the pipes
- Steady state conditions
- Uniform thermal conductivity

SKETCH

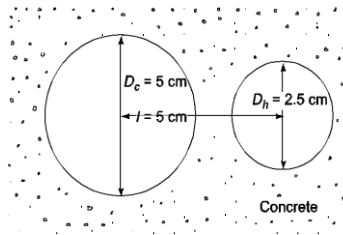

PROPERTIES AND CONSTANTS

Specific heat of water (c_p) = 4187 J/(kg K)

SOLUTION

The shape factor for this geometry is in Table 2.2

$$S = 2\pi / \cosh^{-1} \left(\frac{L^2 - 1 - r^2}{2r} \right)$$

Where

$$L = \frac{l}{D_h} = \frac{0.05\text{ m}}{0.025\text{ m}} = 2 \quad \text{and} \quad r = \frac{r_c}{r_h} = \frac{D_c}{D_h} = \frac{0.05}{0.025} = 2$$

$$\therefore S = 2\pi / \cosh^{-1} \left(\frac{16 - 1 - 4}{4} \right) = 3.763$$

The rate of heat transfer per unit length, from Equation (2.85), is

$$q = kS\Delta T_{\text{overall}} = 0.87\text{ W/(m K)} (3.763) (100^\circ\text{C} - 15^\circ\text{C}) = 278\text{ W/m}$$

COMMENTS

Normally, the temperature of both fluids will change as heat is transferred between them. Hence, for any appreciable length of pipe, an average temperature difference must be used.

PROBLEM 2.63

PROBLEM 2.64

Calculate the rate of heat transfer between a 15-cm-OD pipe at 120°C and a 10-cm-OD pipe at 40°C. The two pipes are 330-m-long and are buried in sand [$k = 0.33 \text{ W/(m K)}$] 12 m below the surface ($T_s = 25^\circ\text{C}$). The pipes are parallel and are separated by 23 cm (center to center) distance.

GIVEN

- Two parallel pipes buried in sand
- Pipe 1
 - Outside diameter (D_1) = 15 cm = 0.15 m
 - Temperature (T_1) = 120°C
- Pipe 2
 - Outside diameter (D_2) = 10 cm = 0.1 m
 - Temperature (T_2) = 40°C
- Length of pipes (L) = 330 m
- Thermal conductivity of the sand (k) = 0.33 W/(m K)
- Depth below surface (d) = 1.2 m
- Surface temperature (T_s) = 25°C
- Center to center distance between pipes (s) = 23 cm = 0.23 m

FIND

- The rate of heat transfer between the pipes (q)

ASSUMPTIONS

- The thermal conductivity of the sand is uniform
- Two dimensional, steady state heat transfer

SKETCH

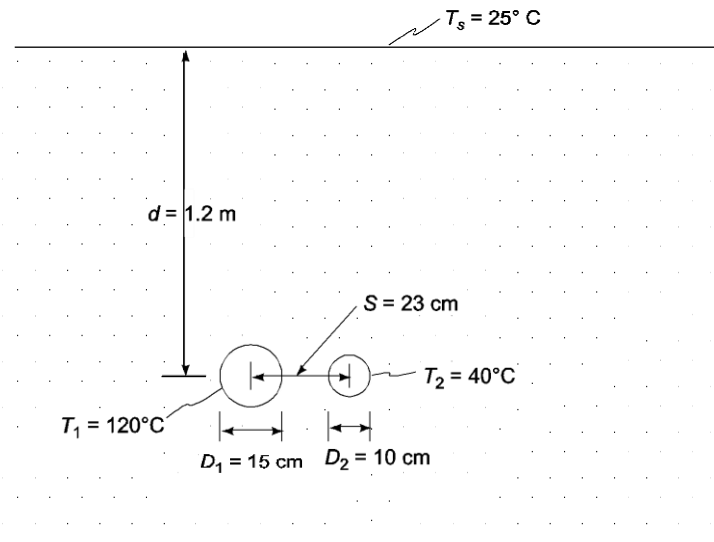

SOLUTION

For the pipe-to-pipe heat transfer, the surface is not important since $Z \gg D$. The shape factor for this geometry, from Table 2.2, is

$$S = \frac{2\pi}{\cosh^{-1}\left(\frac{L^2 - 1 - r^2}{2r}\right)}$$

where $L = \frac{1}{r_2} = \frac{0.23\text{m}}{0.05\text{m}} = 4.6$ and $r = \frac{r_1}{r_2} = \frac{D_1}{D_2} = \frac{15\text{m}}{0.1\text{m}} = 1.5$

$$\therefore S = \frac{2\pi}{\cosh^{-1}\left(\frac{(4.6)^2 - 1 - (1.5)^2}{2(1.5)}\right)} = 2.541$$

The rate of heat transfer per unit length is

$$\frac{q}{L} = kS\Delta T = 0.33 \text{ W/(m K)} (2.541) (120^\circ\text{C} - 40^\circ\text{C}) = 67 \text{ W/m}$$

$$\text{For } L = 330 \text{ m: } q = 67 \text{ W/m} (330 \text{ m}) = 22,100 \text{ W}$$

COMMENTS

Normally, the temperature of both fluids will change as heat is transferred between them. Hence, for any appreciable length of pipe, an average temperature difference must be used.

Chapter 2: Concept Review Questions

- 2.1 Consider steady-state heat conduction in a semi-infinite plate or slab of thickness L , a very long hollow cylinder, and a hollow sphere of inner radius r_i and outer radius r_o . Assuming uniform conductivity k in the plate, write the conduction equation and express the respective thermal resistance for each of the three geometries.
- 2.2 What is the primary purpose of adding fins to a heat transfer surface? Consider a plate separating two fluids, A and B, with respective convection heat transfer coefficients \bar{h}_{cA} and \bar{h}_{cB} such that $\bar{h}_{cA} \gg \bar{h}_{cB}$. To what side of the plate surface should fins be added and why? In choosing the size of these fins, would you make them as long as the available space would permit? Why or why not?

Chapter 2: Concept Review Solutions

- 2.1 Consider steady-state heat conduction in a semi-infinite plate or slab of thickness L , a very long hollow cylinder, and a hollow sphere of inner radius r_i and outer radius r_o . Assuming uniform conductivity k in the plate, write the conduction equation and express the respective thermal resistance for each of the three geometries.**

Semi-infinite plate or slab of thickness L : $\frac{d^2T}{dx^2} = 0$

For heat flow from the hot side at T_H to the cold side at T_C the heat transfer rate is

$$q_k = -kA \frac{\Delta T}{L} = \frac{(T_H - T_C)L}{R_{th}},$$

where the thermal resistance is $R_{th} = \frac{L}{kA}$ and A is the surface area of the plate.

Long hollow cylinder of radii r_i and r_o : $\frac{d}{dr} \left(r \frac{dT}{dr} \right) = 0$

For heat flow from the inside of the cylinder to the outside ($T_i > T_o$), the heat transfer rate is

$$q_k = 2\pi Lk \frac{(T_i - T_o)}{\ln(r_o/r_i)} = \frac{(T_i - T_o)L}{R_{th}},$$

where the thermal resistance is $R_{th} = \frac{\ln(r_o/r_i)}{2\pi Lk}$ and L is the length of cylinder.

Hollow sphere of radii r_i and r_o : $\frac{1}{r^2} \frac{d}{dr} \left(r^2 \frac{dT}{dr} \right) = 0$

For heat flow from the inside of the sphere to the outside ($T_i > T_o$), the heat transfer rate is

$$q_k = 4\pi r_o r_i k \frac{(T_i - T_o)}{(r_o - r_i)} = \frac{(T_i - T_o)L}{R_{th}},$$

where the thermal resistance is $R_{th} = \frac{r_o - r_i}{4\pi r_o r_i k}$.

2.2 What is the primary purpose of adding fins to a heat transfer surface? Consider a plate separating two fluids, A and B, with respective convection heat transfer

coefficients \bar{h}_{cA} and \bar{h}_{cB} such that $\bar{h}_{cA} \gg \bar{h}_{cB}$. To what side of the plate surface should fins be added and why? In choosing the size of these fins, would you make them as long as the available space would permit? Why or why not?

The primary purpose of adding fins to a heat transfer surface is to increase its surface area so that it can increase the rate of heating or cooling, or *heat transfer enhancement*. In explanation, consider a surface of area A that exchanges heat by convection with its surroundings (e.g. cooling air flow over a heat dissipating microelectronic processor) for which the heat transfer rate can be expressed as

$$q_c = \bar{h}_c A \Delta T$$

Thus, for fixed ΔT and \bar{h}_c , a higher heat transfer rate q_c can be sustained by increasing the surface area A by adding fins. Another way to look at this problem is that by increasing A , the same heat transfer rate q_c can be accommodated with a much smaller temperature difference ΔT . Such considerations are important for the design of many heat exchangers in chemical processing plants, waste-heat recovery systems, micro-electronics cooling, and solar thermal energy conversion.

The overall thermal resistance of the two fluids, A and B, and the plate separating them is given by

$$R_o = R_{cA} + R_{plate} + R_{cB} = \left(\frac{1}{\bar{h}_{cA} A} \right) + R_{plate} + \left(\frac{1}{\bar{h}_{cB} A} \right)$$

Thus, if $\bar{h}_{cA} \gg \bar{h}_{cB}$ then $R_{cB} \gg R_{cA}$ and if the plate thermal resistance is much smaller

than either of the two convection resistances, fins should be added to side B of the plate so that R_{cB} could be reduced.

In choosing the size of fins, optimization based on length of fin is not very useful because fin efficiency decreases with increasing fin length (fin efficiency is 100% for the trivial case of zero fin length). What is more important is the relative increase in the heat transfer surface area with the addition of fins, which have a reasonably high efficiency (relatively short fins). For this, the number of fins becomes more important and generally thin, slender, closely space fins provide the most benefit (compared to fewer and thicker fins).