

Solution Manual for Programmable Logic Controllers 5th Edition  
Petruzella 0073373842 9780073373843

Full link download

Solution Manual:

<https://testbankpack.com/p/solution-manual-for-programmable-logic-controllers-5th-edition-petruzella-0073373842-9780073373843/>

Test Bank:

<https://testbankpack.com/p/test-bank-for-programmable-logic-controllers-5th-edition-petruzella-0073373842-9780073373843/>

**Answers to Chapter 2 Review Questions**

1. To accept signals from the machine or process devices and to convert them into signals that can be used by the controller
2. To convert controller signals into external signals that are used to control the machine or process
3. a) A rack that is located away from the processor module near the field devices  
b) To minimize the amount of wiring required
4. By its address
5. Type                      refers to an input or output  
  
Word and bit              refers to the actual module terminal connection
6. Bit level addressing specifies a discrete device that is connected to a specific terminal. Word level addressing specifies an analog device connected to a module that uses a word of information.
7. In tag-based addressing you use a tag (alphanumeric name) to address data (variables). In rack/slot-based addressing a fixed numeric format is used to identify the address data.
8. An input/output PC interface card
9. Combination I/O modules
10. Connections for the power supply

11. For ease of wiring and replacing modules
12. The advantage with the high-density module is that it is possible to install up to 64 inputs or outputs in one slot for greater space savings. The disadvantage is that the high-density output modules cannot handle as much current per output.
13. ON/OFF devices such as selector switches, pushbuttons and limit switches
14. ON/OFF devices such as lights, solenoids and motor starters
15. The backplane supplies current and voltage for the modules from the power supply
16. An optical isolator is used to provide electrical isolation between the field wiring and the PLC backplane internal circuitry.

17. Power and Logic sections
18. Senses when a signal is received
  - Converts the input signal to the correct voltage level
  - Isolates the PLC from the input voltage or current
  - Sends a signal to the processor indicating which sensor originated the signal
19. Triac
20. a) 1 amp per point
  - b) A control relay is connected to the output module. The contacts of the control relay are then used to control the larger load.
21. Transistor
22. A discrete relay-type module uses an electromechanical relay element for switching which allow it to work for AC or DC applications.
23. a) Sinking and sourcing are terms used to describe a current signal flow relationship between field input and output devices in a control system and their power supply.
  - b) Sourcing
24. Discrete I/O modules allow only ON/OFF devices to be connected. Analog I/O modules allow analog or varying voltage or current devices to be connected.
25. Used to convert analog signals to an equivalent digital value
26. Used to convert digital signals to an equivalent analog value
27. Voltage sensing and current sensing
28. Temperature, speed, level, flow, weight, pressure, and position
29. A twisted shielded pair cable is used in wiring the circuit to reduce unwanted electrical noise signals that can be induced in the conductors from other wiring
30. Unipolar modules can accept an input signal that varies in the positive direction only. Bipolar signals swing between a maximum negative value and a maximum positive value.
31. The analog input channel is capable of sensing voltages down to 0.3V increments.
32. The loop power may be supplied by the sensor or may be provided by the analog output module
33. Control valves, chart recorder, electronic drives

34. a) Used to count pulses such as motor encoders that occur at very high speeds  
b) Allows the use of thumbwheel switches for feeding information to a PLC  
c) Allows the transmitting and receiving of TTL signals for communication with the PLC's processor  
d) Used to monitor the output of incremental or absolute encoders  
e) Allows the transmitting and receiving of ASCII files  
f) Provides pulse trains to a stepper-motor translator, which enables control of a stepper motor  
g) Enables a PLC to operate devices that require BCD-coded signals
35. a) Used to maintain a process variable such as temperature, flow, level, or speed within set limits of a specified set point.  
b) Used in applications involving accurate high-speed machining and packaging operations  
c) Used to establish point-to-point connections with other intelligent devices for the exchange of data
36. a) Specifies the magnitude and type of voltage signal that will be accepted by the input  
b) Specifies a minimum ON-state voltage that is the minimum voltage at which logic 1 is recognized as absolutely ON; and a maximum OFF-state voltage which is the voltage at which logic 0 is recognized as absolutely OFF  
c) Specifies the minimum input current that the input devices must be capable of driving to operate the input circuit  
d) Specifies what the maximum temperature of the air surrounding the I/O modules should be for best operating conditions  
e) Specifies the maximum time duration required by an input module's circuitry to recognize that a field device has switched ON (input ON-delay) or switched OFF (input OFF-delay)  
f) Specifies the magnitude and type of user supply voltage at which a discrete output module is designed to operate  
g) Specifies the maximum current that a single output and the module as a whole can safely carry under load (at rated voltage)  
h) Specifies the maximum inrush current and duration for which an output circuit can exceed its maximum continuous current rating  
i) This specification will designate whether the particular module's design has individual protection for each circuit or if fuse protection is provided for groups (e.g. 4 or 8) of outputs  
j) Specifies the amount of current still conducting through an output circuit even after the output has been turned off  
k) Rates the module's capacity for sustaining an excessive voltage at its input or output terminal  
l) This specification defines the number of field inputs or outputs that can be connected to a single module  
m) This value indicates the amount of current the module requires from the backplane
37. a) Specifies the number of analog channels that can be connected to the module  
b) The voltage or current signal ranges that an analog input module is designed to accept  
c) This specification defines the current or voltage signal ranges that a particular analog

output module is designed to output under program control

d) Analog input circuits are usually protected against accidentally connecting a voltage that exceeds the specified input voltage range

e) This specification determines the smallest measurable unit of current or voltage the module can measure

f) For analog I/Os, these values must be matched to the external device connected to the module

g) Refers to an analog module's ability to prevent noise from interfering with data integrity on a single channel and from channel to channel on the module

38. The CPU section executes the program and makes the decisions needed by the PLC to operate and communicate with other modules. The memory section electronically stores the PLC program along with other retrievable digital information

39. a) The power supply converts 115 VAC or 230 VAC into the usable DC voltage required by the CPU, memory, and I/O electronic circuitry

b) the length of time a PLC can tolerate a power loss

40. Allows transfer of control to the second processor in the event of a processor fault

41. Run mode, program mode, and remote mode

42. Timing, counting, latching, comparing, motion control and complex math functions

43. Ground yourself by touching a conductive surface before handling static-sensitive components

Wear a wrist strap that provides a path to bleed off any charge that may build up during work  
Be careful not to touch the backplane connector or connector pins of the PLC system (always handle the circuit cards by the edge if possible)

Be careful not to touch other circuit components in a module when you configure or replace its internal components

When not in use, store modules in its static-shield bag.

44. a) Data are stored in memory locations by a process called *writing*

b) Data are retrieved from memory by what is referred to as *reading*

c) Individual piece of memory in the form of 1's or 0's

d) Memory *location* refers to an address in the CPU's memory where a binary word can be stored

e) Memory *utilization* refers to the number of memory locations required to store each type of instruction

45. a) The status of all input and output devices

b) 1

c) 0

d) 1

e) 0

46. To be sure that the PLC memory has not been corrupted
47. Volatile: Loses all its stored information if all operating power is lost or removed. Memory is easily altered and usually supported by a battery backup power supply  
Nonvolatile: Retains stored information when the power is accidentally or intentionally removed. Memory is generally unalterable.
48. ROM is normally used to store the programs and data that define the capabilities of the PLC.
49. RAM is used as a temporary storage area of data that may need to be quickly changed
50. An EEPROM memory module is used to store, back up, or transfer PLC programs
51. They are extremely fast at saving and retrieving files
52. Allows the user to enter, change or monitor a PLC program
53. Handheld programmers are compact, inexpensive, and easy to use but they have limited display capabilities.
54. Appropriate programming software
55. Typical capabilities of the programming software include on-line and off-line program editing, on-line program monitoring, program documentation, diagnosing malfunctions in the PLC and troubleshooting the controlled system
56. One
57. Replace hard-wired pushbuttons and pilot lights with realistic-looking icons  
Show operations in graphic format  
Allow the operator to change timer and counter presets  
Show alarms, complete with time of occurrence and locations  
Display variables as they change over time
58. Set up the communication with the PLC.  
Create the tag database.  
Insert the graphical objects on the screen. Animate the objects.
59. Values of process variables, such as flow, temperature over a period of time.
60. The changing a input or output quantity from one notation to another.
61. A transducer converts a field device's variable (e.g., pressure, temperature etc.) into a very low-level electric signal (current or voltage).

62. A base tag defines a memory location where data are stored. An alias tag is used to create an alternate name (alias) for a tag.

# CHAPTER 2

## PLC Hardware Components

### TEST 2.1

Choose the letter that best completes the statement.

Answer

1. A \_\_\_\_ is an example of a device that could be used to provide a discrete input to a PLC.

1. **d**

- a) pushbutton
- b) selector switch
- c) limit switch
- d) all of the above

2. A \_\_\_\_ is an example of an actuator that could be controlled by a discrete output from a PLC.

2. **b**

- a) pushbutton
- b) motor starter
- c) limit switch
- d) all of the above

3. A/An \_\_\_\_ input or output is a continuously variable signal within a designated range.

3. **d**

- a) discrete
- b) digital
- c) BCD
- d) analog



4. One function of a PLC input interface module is to: 4. **a**
- a) accept signals from field devices and convert them into signals that can be used by the processor.
  - b) convert signals from the processing unit into values that can be used to control the machine or process.
  - c) input signals from the programming device and convert them into signals that can be used by the CPU.
  - d) interpret and execute the user program that controls the machine or process.
5. The location of a specific input or output field device is identified by the processor by means of its: 5. **d**
- a) voltage rating.
  - b) current rating.
  - c) wattage rating.
  - d) address.
6. A discrete output interface module is designed to provide: 6. **c**
- a) output voltages only in the 5 VDC range.
  - b) varying AC or DC voltages depending on the type of module selected.
  - c) ON/OFF switching of the output field device.
  - d) binary-coded outputs.
7. The following statement that does *not* apply to the optical isolator circuit used in I/O modules is that it: 7. **b**
- a) separates high voltage and low voltage circuits
  - b) rectifies AC signals.
  - c) prevents damage caused by line voltage transients.
  - d) reduces the effect of electrical noise.

8. Individual outputs of a typical AC output interface module usually have a maximum current rating of about: 8. **a**
- a) 1 A or 2 A. c) 50 mA or 100 mA.  
b) 25 A or 50 A. d) 250  $\mu$ A or 500  $\mu$ A
9. Which of the following input field devices would most likely be used with an analog interface input module? 9. **d**
- a) Pushbutton c) Selector switch  
b) Limit switch d) Thermocouple
10. The "ON state input voltage range" specification refers to: 10. **d**
- a) the type of voltage device that will be accepted by the input.  
b) range of leakage voltage present at the input in its ON state.  
c) minimum and maximum output operating voltages.  
d) voltage at which the input signal is recognized as being ON.
11. Volatile memory elements can be classified as those that: 11. **a**
- a) do not retain stored information when the power is removed.  
b) retain stored information when the power is removed.  
c) do not require a battery backup.  
d) both b and c.
12. \_\_\_\_\_ memory is used by the PLC's operating system. 12. **d**
- a) RAM c) Flash  
b) EEPROM d) ROM

13. \_\_\_\_\_ is a type of memory commonly used for temporary storage of data that may need to be quickly changed. 13. **a**

- a) RAM
- b) ROM
- c) EPROM
- d) EEPROM

14. The most common form of memory used to store, back up, or transfer PLC programs is: 14. **d**

- a) RAM
- b) Flash EEPROM
- c) EEPROM
- d) both b and c

15. In event of a power interruption, a \_\_\_\_\_ is used in some processors to provide power to the RAM. 15. **b**

- a) inductor
- b) capacitor
- c) transistor
- d) resistor

16. Which of the following is *not* a function of a PLC programming device? 16. **c**

- a) To enter the user program
- b) To change the user program
- c) To execute the user program
- d) To monitor the user program

17. Status indicators are provided on each output of an output module to indicate that the: 17. **d**

- a) load has been operated.
- b) input associated with the output is active.
- c) module fuse has blown.
- d) output is active.

d) output is active.

18. The I/O system provides an interface between: 18. **b**

- a) input modules and output modules.
- b) the CPU and field equipment.
- c) the CPU and I/O rack.
- d) the I/O rack and I/O modules.

19. The PLC chassis comes in different sizes according to the: 19. **c**

- a) size of the program.
- b) type of I/O modules used.
- c) number of slots they contain.
- d) all of the above.

20. The Allen-Bradley SLC-500 address I:2/4 refers to an: 20. **c**

- a) Input module in slot 4, terminal 2.
- b) Output module in slot 4, terminal 2.
- c) Input module in slot 2, terminal 4.
- d) Output module in slot 2, terminal 4.

21. The Allen-Bradley SLC-500 address O:3/0 refers to an: 21. **b**

- a) Input module in slot 3, terminal 0.
- b) Output module in slot 3, terminal 0.
- c) Input module in slot 0, terminal 3.
- d) Output module in slot 0, terminal 3.

22. For the I/O module of Figure 2-1, the arrows point to the: 22. **d**

- a) status indicator connections.

- b) input connections.
- c) output connections.
- d) power supply connections.

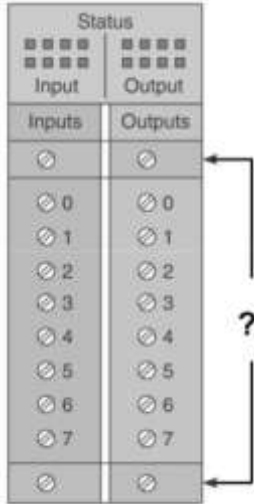
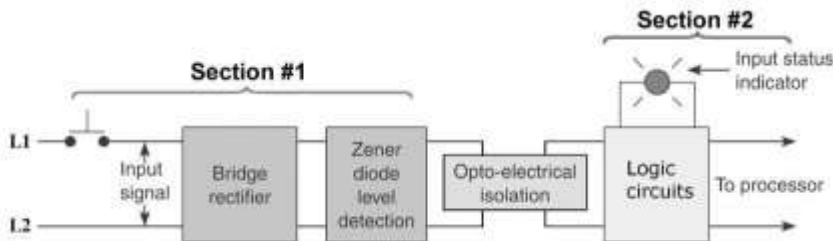

**Figure 2-1 I/O module for question 22.**

23. For the block diagram of the input module shown in Figure 2-2, Section #1 represents the \_\_\_\_\_ and #2 the \_\_\_\_\_.

23.c

- a) AC, DC.
- b) DC, AC.
- c) power, logic.
- d) logic, power.



**Figure 2-2 Block diagram for question 23.**

24-1. The schematic diagram of Figure 2-3 is that of a(n): 24-1. **c**  
a) discrete output module.                      c) discrete input module.  
b) analog output module.                      d) analog input module.

24-2. The purpose of the filter section is to: 24-2. **c**  
a) aid in fault diagnosis.  
b) set the minimum level of voltage that can be detected.  
c) protect against electrical noise interference.  
d) separate the higher line voltage from the logic circuits .

24-3 The purpose of the zener diode ( $Z_D$ ) is to: 24-3. **b**  
a) aid in fault diagnosis.  
b) set the minimum level of voltage that can be detected.  
c) protect against electrical noise interference.  
d) separate the higher line voltage from the logic circuits .

24-4 The purpose of the LED indicator is to: 24-4. **a**  
a) aid in fault diagnosis.  
b) set the minimum level of voltage that can be detected.  
c) protect against electrical noise interference.  
d) separate the higher line voltage from the logic circuits .

24-5 The purpose of the optical isolator is to 24-5. **d**  
a) aid in fault diagnosis.  
b) set the minimum level of voltage that can be detected.  
c) protect against electrical noise interference.  
d) separate the higher line voltage from the logic circuits .

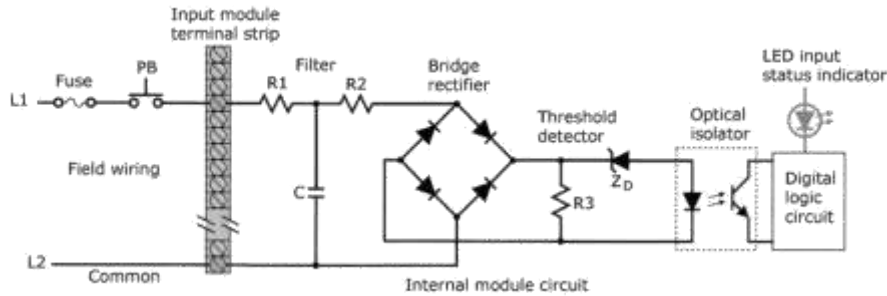
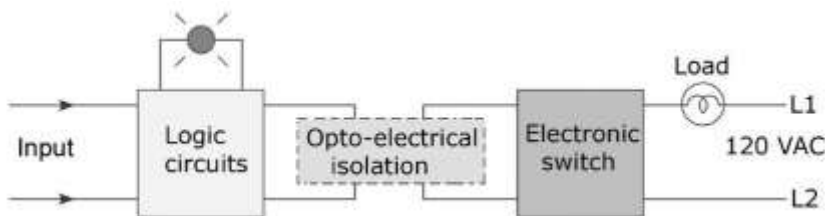

**Figure 2-3 Schematic diagram for question 24.**

25. For the block diagram of the output module shown in Figure 2-4, the input comes from the:

25. **b**

- a) input field device
- b) processor.
- c) output field device.
- d) line power supply.



**Figure 2-4 Block diagram for question 25.**

26-1. The schematic diagram of Figure 2-5 is that of a(n):

26-1. **a**

- a) discrete output module.
- b) analog output module.
- c) discrete input module.
- d) analog input module.

26-2. The input signal to the module comes from:

26-2. **c**

- a) the input field device.

- b) the output field device.
- c) internal logic circuitry of the processor.
- d) either a or b.

26-3 The purpose of the triac switch is to:

26-3. **a**

- a) turn the load ON and OFF.
- b) vary the current flow to the load in accordance with the input signal level.
- c) vary the voltage across the load in accordance with the input signal level.
- d) both b and c.

26-4 When the triac is in the OFF state:

26-4. **b**

- a) zero current always flows through the load.
- b) a small leakage current may flow through the load.
- c) the rated surge current flows through the lamp.
- d) the rated nominal current flows through the lamp.

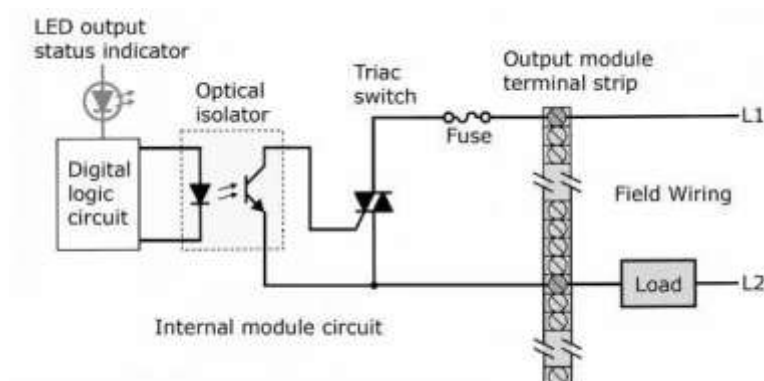

**Figure 2-5 Schematic diagram for question 26.**



27. The schematic diagram of Figure 2-6 is an example of 27. **d**  
 how a PLC output module is connected to:  
 a) isolate the load from the controller.      c) vary the speed of a motor.  
 b) control a high resistance.                      d) control a high current load.

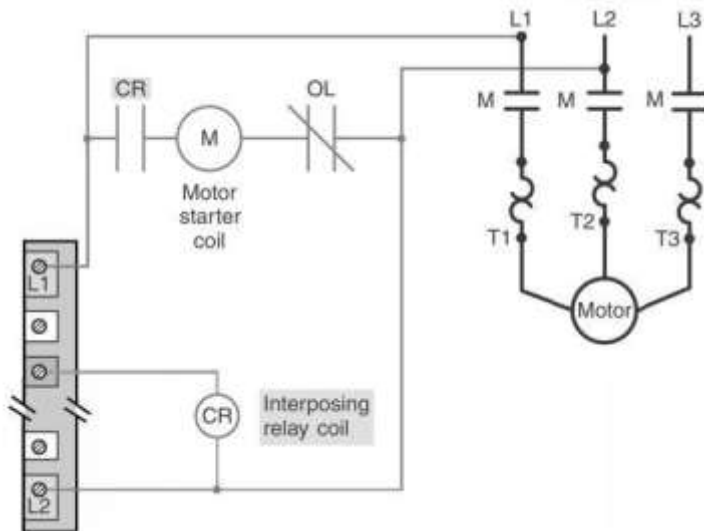

**Figure 2-6 Schematic diagram for question 27.**

28. Which of the following devices can be used for switching 28. **d**  
 the output of a discrete DC output module?  
 a) Transistor.    c) relay.  
 b) Triac.    d) either a or c.
29. The current sourcing sensor shown in Figure 2-7 29. **a**  
 must be matched with a \_\_\_\_\_ PLC input module.  
 a) current sinking.  
 b) current sourcing.  
 c) alternating current.  
 d) either a or b.

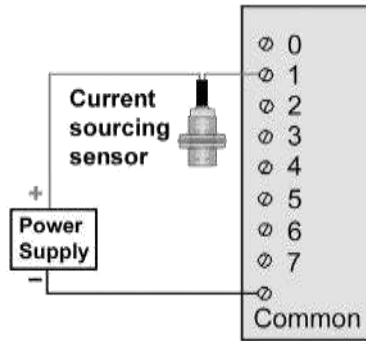

**Figure 2-7 Current sourcing sensor for question 29.**

30. Typical analog inputs and outputs can vary from

30. **d**

- a) 0 to 20 mA
- b) 4 to 20 mA
- c) 0 to 10 volts
- d) all of the above

31. For the block diagram of the analog PLC control shown in Figure 2-8, which part has a binary input and analog output value?

31. **d**

- a) Level transmitter
- b) Input module
- c) Processor
- d) Output module

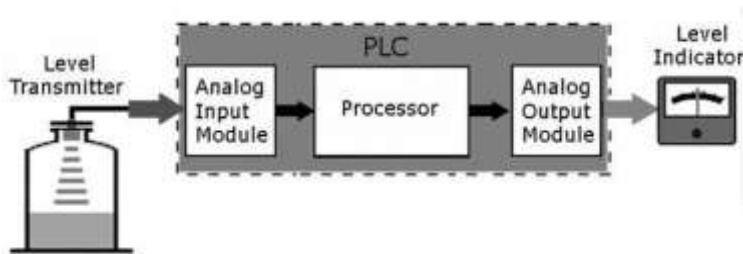

**Figure 2-8 Block diagram for question 31.**

32-1 For the thermocouple analog input module

32-1. **a**

shown in Figure 2-9, shielded cable is used to:

- a) reduce unwanted electrical noise signals.
- b) carry the higher current required.
- c) lower the resistance of the conductors.
- d) insulate the circuit from other cables.

32-2 The thermocouple shown is a:

32-2. **a**

- a) ungrounded type with the shield grounded at the module end.
- b) ungrounded type with the shield grounded at the thermocouple end.
- c) grounded type with the shield grounded at the module end.
- d) grounded type with the shield grounded at the thermocouple end.

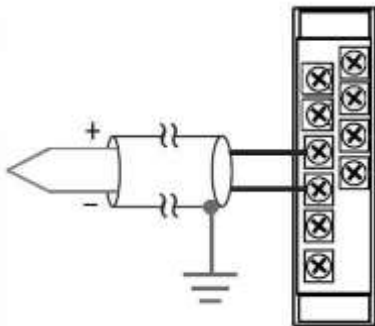

**Figure 2-9 Block thermocouple input module for question 32.**

33. The main element of an analog output module is:

33. **d**

- a) AC to DC rectifier.
- b) DC to AC inverter.
- c) analog to digital converter.
- d) digital to analog converter.

34. For the PLC analog I/O control system shown in

34. **a**

Figure 2-10, the fluid flow is controlled by

- a) varying the amount of the valve opening.
- b) switching the valve ON and OFF.
- c) switching the level sensor ON and OFF.
- d) varying the position of the level sensor.

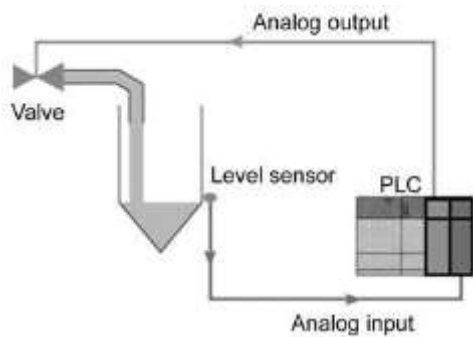

**Figure 2-10 Analog I/O system for question 34.**

35. Which of the following special I/O modules would be used to operate a seven-segment LED Display?

35. **b**

- a) Encoder-counter module.
- b) BCD-output module.
- c) Stepper-motor module.
- d) High-speed counter module.

36. A \_\_\_\_\_ module is used to establish connections for the exchange of data.

36. **b**

- a) thumbwheel
- b) communication
- c) servo
- d) PID

37. High-density I/O modules: 37. **a**

a) may have up to 64 inputs or outputs per module.

b) require more space.

c) can handle greater amounts of current per output.

d) all of the above.

38. Discrete I/O modules can be classified as: 38. **a**

a) bit oriented.

c) processor oriented.

b) word oriented.

d) power supply oriented.

39. Which of the following specifications defines the number of 39. **b**  
field inputs or outputs that can be connected to a single module?

a) Electrical isolation.

b) Points per module.

c) Threshold voltage.

d) Current per input.

40. The \_\_\_\_\_ of an analog I/O module specifies how 40. **c**  
accurately an analog value can be represented digitally.

a) number of inputs and outputs per card

b) input impedance and capacitance

c) resolution

d) common mode rejection ratio

41. The processor module of the PLC is where the: 41. **a**

a) ladder logic program is stored.

b) input connections are made.

- c) output connections are made.
- d) sensors are located.

42. For the processor module shown in Figure 2-11, Block 1 represents the \_\_\_ and Block 2 the \_\_\_.

42. **d**

- a) input, output
- b) output, input
- c) memory, CPU
- d) CPU, memory

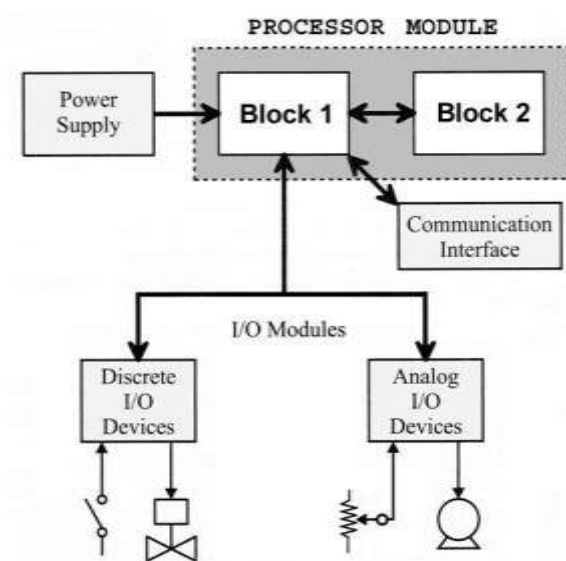

**Figure 2-11 Processor module for question 42.**

43. When placed in the \_\_\_\_\_ mode, the processor does not scan/execute the ladder program.

43. **a**

- a) program
- b) run
- c) test
- d) remote

44. The most commonly used programming device is a: 44. **a**
- a) personal computer.
  - b) dedicated industrial programming terminal.
  - c) hand-held programmer.
  - d) proprietary programming device.
45. Electronic components found in PLC modules 45. **d**
- a) are not effected by electrostatic voltages.
  - b) can be damaged by electrostatic voltages.
  - c) can have their performance degraded by electrostatic voltages.
  - d) both b and c.
46. Batteries are used in a PLC's processor to 46. **b**
- a) operate the status lights LEDs.
  - b) maintain data in volatile memory when line power is removed from the processor.
  - c) maintain data in nonvolatile memory when line power is removed from the processor.
  - d) maintain outputs through a power failure.
47. The \_\_\_ tag is often used to create a tag name to represent 47. **c**  
a real world input or output.
- a) base
  - b) predefined
  - c) alias
  - b) INT

48. The resizing of a signal to meet the requirements of the using component of a PLC system is known as 48. **a**
- a) scaling c) amplification  
 b) grading b) protocol

49. For the HMI package shown, the unlabeled block represents the 49. **b**
- a) processor c) input module  
 b) tag database b) output module

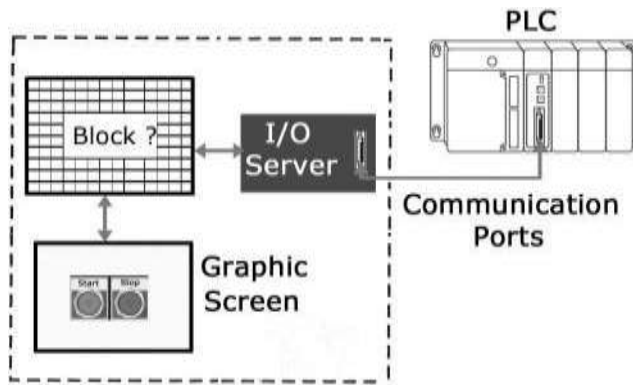

50. A fault condition which is present but the HMI alarm message has not been acknowledged by the operator is said to be in the \_\_\_ state. 50. **a**
- a) active c) ready  
 b) inactive b) OK

51. Which of the following HMI program features provides the ability to chart the progress of a process in real time in a manner similar to that of a strip chart recorder? 51 **a**
- a) Tend c) Graphics Library  
 b) Alarms b) Event History



# CHAPTER 2

## PLC Hardware Components

### TEST 2.2

Place the answers to the following questions in the answer column at the right.

Answer

1. An analog input or output is a signal that varies continuously within a certain range. (True or False) 1. **True**
  
2. The I/O section of a PLC system can consist of an I/O rack and individual I/O \_\_\_\_ . 2. **modules**
  
3. The location of a module within a rack and the terminal number of a module to which an input or output device is connected will determine the device's \_\_\_\_\_. 3. **address**
  
4. Most input modules have blown fuse indicators. (True or False) 4. **False**
  
5. The I/O address is used by the processor to identify where the device is \_\_\_\_\_. 5. **located**
  
6. A standard I/O module consists of a(n) 6a. **circuit**  
(a) \_\_\_\_\_ board and a(n) (b) \_\_\_\_\_ assembly. 6b. **terminal**

7. I/O modules are designed to plug into a slot or connector. 7. **True**  
(True or False)
8. Discrete I/O interfaces allow only \_\_\_ type devices to be connected. 8. **ON/OFF**
9. I/O modules' circuitry can be divided into two basic sections: the (a) \_\_\_\_\_ section and the (b) \_\_\_\_\_ section. 9a **power**  
9b **logic**
10. Optical isolation used in I/O modules helps to reduce the effects of electrical noise. (True or False) 10. **True**
11. AC output modules often use a solid-state device such as a(n) \_\_\_\_\_ to switch the output ON and OFF. 11. **Triac**
12. I/O modules are keyed to prevent unauthorized personnel from removing them from the I/O rack. (True or False) 12. **False**
13. The maximum current rating for the individual outputs of an AC output module is usually in the 20 to 30 ampere range. (True or False) 13. **False**
14. A(n) \_\_\_\_\_ relay is used for controlling larger load currents. 14. **interposing**

15. Analog input interface modules contain a(n) \_\_\_\_\_ converter circuit. 15. **Analog to Digital**

16. A thermocouple would be classified as an analog input sensing device. (True or False) 16. **True**

17. Shielded twisted pair cable is used for connecting to thermocouple inputs to reduce unwanted electrical noise. (True or False) 17. **True**

18. Electrical noise usually causes permanent operating errors. (True or False) 18. **False**

19. Match each of the following specifications with the appropriate description. Place the number from the specifications list in the answer column.

**SPECIFICATIONS**

- 1) nominal current per input
- 2) ON-state input voltage range
- 3) OFF-state leakage current
- 4) electrical isolation
- 5) input delay
- 6) nominal input voltage
- 7) surge current
- 8) output voltage range
- 9) maximum output current rating
- 10) nominal output voltage

**DESCRIPTIONS**

- a) Maximum voltage isolation between the I/O circuits and the controller logic circuitry. 19a. **4**
- b) Maximum value of current that flows through the output in its OFF state. 19b. **3**
- c) Maximum inrush current and duration an output module can withstand. 19c. **7**
- d) Maximum current that a single output and the module as a whole can safely carry. 19d. **9**
- e) Minimum and maximum output operating voltages. 19e. **8**
- f) Magnitude and type of voltage source that can be controlled by the output. 19f. **10**
- g) Duration for which the input must be ON before being recognized as a valid input. 19g. **5**
- h) Minimum input current that the input device must be capable of driving to operate the input circuit. 19h. **1**
- i) Voltage level at which the input signal is recognized as being ON. 19i. **2**
- j) Magnitude and type of voltage signal that will be accepted by the input. 19j. **6**
20. The processor continually interacts with the \_\_\_\_\_ to interpret and execute the user program. 20. **I/O**
21. The processor may perform functions such as timing, counting, and comparing in addition to logic processing. (True or False) 21. **True**

22. Memory is where the control plan is held or stored in the controller. (True or False) 22. **True**
23. One \_\_\_ is a memory location that may store one binary number that has the value of either 1 or 0. 23. **bit**
24. A volatile memory will lose its programmed contents if operating power is lost. (True or False) 24. **True**
25. A nonvolatile memory will retain its programmed contents if operating power is lost. (True or False) 25. **True**
26. RAM memory is nonvolatile. (True or False) 26. **False**
27. Information stored in a RAM memory location can be written into or read from. (True or False) 27. **True**
28. When a new program is loaded into a PLC's memory, the old program that was stored in the same locations is over-written and essentially erased. (True or False) 28. **True**
29. The type of battery typically used PLC processors is \_\_\_\_\_. 29. **lithium**
30. Flash memory functions similar to \_\_\_ memory. 30. **EEPROM**

31. Most PLC programming software will allow you to develop programs on another manufacturer's PLC. (True or False) 31. **False**
32. Analog signals can have only two states. (True or False) 32. **False**
33. Memory modules used to copy a program from one PLC to another usually contain \_\_\_ memory. 33. **EEPROM**
34. A modular PLC that has room for several I/O modules, 34. **True**  
is capable of being customized for a particular application.  
(True or False)
35. Remote I/O racks are linked to the local rack through a(n) \_\_\_ module. 35. **communications**
36. In general, rack/slot-based addressing elements include: (a) \_\_, (b) \_\_, and (c) \_\_. 36a. **Type**  
36b. **Slot**  
36c. **Word and Bit**
37. I/O modules are normally installed or removed while the PLC is powered. (True or False) 37. **False**
38. A module inserted into the wrong slot could be damaged. (True or False) 38. **True**

39. Modules receive voltage and current for proper operation from the \_\_\_\_\_ of the rack enclosure. 39. **backplane**
40. The two basic types of analog input modules are (a) \_\_\_sensing and (b) \_\_\_sensing. 40a. **voltage**  
40b. **current**
41. Intelligent I/O modules have their own \_\_\_\_\_ on board. 41. **microprocessor**
42. A redundant PLC system is configured using two processors. (True or False) 42. **True**
43. Most PLC electronic components are not sensitive to electrostatic discharge. (True or False) 43. **False**
44. Answer each of the following for the I/O module and status table shown in Figure 2-12.
- a) The type of module shown is a(n) \_\_\_\_\_ (discrete or analog) module. 44a. **discrete**
- b) The type of image table shown is a(n) \_\_\_ image table. 44b. **input**
- c) The status light indicator associated with device #1 would be \_\_\_\_\_. (ON or OFF) 44c. **ON**
- d) The status light indicator associated with device #2 would be \_\_\_\_\_. (ON or OFF) 44d. **OFF**
- e) The value stored in memory for device #1 would be \_\_\_\_\_. 44e. **1**
- f) The value stored in memory for device #2 would be \_\_\_\_\_. 44f. **0**

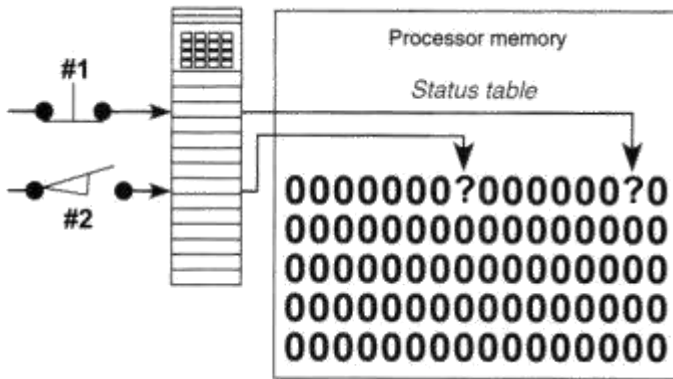

**Figure 2-12 I/O module and table for question 44.**

45. Answer each of the following for the I/O module and status table shown in Figure 2-13.

- a) The type of module shown is a(n) \_\_\_\_\_ (discrete or analog) module. 45a. **discrete**
- b) The type of image table shown is a(n) \_\_\_\_\_ image table. 45b. **output**
- c) The status light indicator associated with PL1 would be \_\_\_\_\_. (ON or OFF) 45c. **ON**
- d) The status light indicator associated with PL2 would be \_\_\_\_\_. (ON or OFF) 45d. **ON**
- e) PL1 would be switched \_\_\_\_\_. (ON or OFF). 45e. **ON**
- f) PL2 would be switched \_\_\_\_\_. (ON or OFF). 45f. **ON**

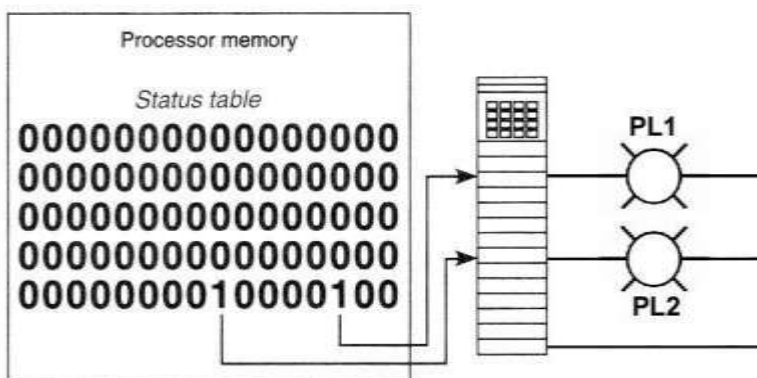

**Figure 2-13 I/O module and table for question 45.**



46. One advantage of discrete relay contact output modules is that they can be used with AC or DC devices. (True or False) 46. **True**

47. If you had a hand-held programming terminal from one manufacturer you can program only that manufacturer's PLC using it. (True or False) 47. **True**

48. Hot swappable I/O modules are designed to be changed with the power on and the PLC operating. (True or False) 48. **True**

49. Identify data types (a) \_\_ , (b) \_\_, and (c) shown in Figure 2-14. 49a. **bit**

49b. **byte**

49c. **word**

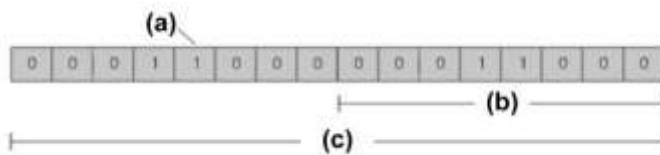

**Figure 2-14 Data types for question 49.**

50. HMI screens are developed using a software package on a PC which is downloaded into the PLC operator interface device. (True or False) 50. **True**

51. Discrete means that each input or output has two states: true (on) or false (off). (True or False) 51. **True**

52. Light is used in I/O modules to separate the real-world electrical signals from the PLC internal electronic system. 52. **True**

53. Digital modules are also called discrete modules. **53. True**  
(True or False)
54. The sum of the backplane current drawn for all modules **54. True**  
in a chassis is used to select the appropriate chassis  
power supply rating. (True or False)

## Programming Assignments

### For Chapter 2

1. For the PLC you will be working with, summarize the specifications for the:
  - (a) input module(s)
  - (b) output module(s)
  - (c) processor
  - (d) power supply

**Answers will vary according to the PLC used.**

2. (a) Program your controller to operate according to Figure 2-15.
  - (b) Download the program to the PLC
  - (c) Run the program and observe the status of the bits stored in the input and output image tables.

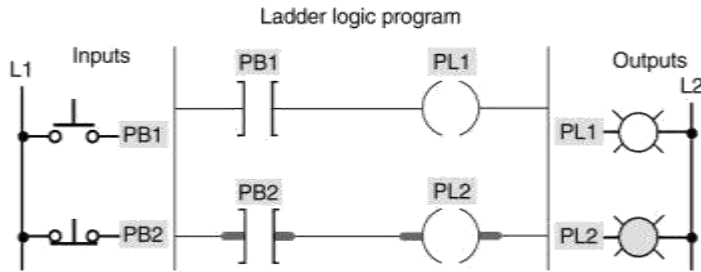

**Figure 2-15 Program for assignment 2.**

**Answers will vary according to the PLC used.**

3. (a) Program your controller to operate according to Figure 2-16.
- (b) Download the program to the PLC
- (c) Run the program and observe the status of the bits stored in the input and output image tables.

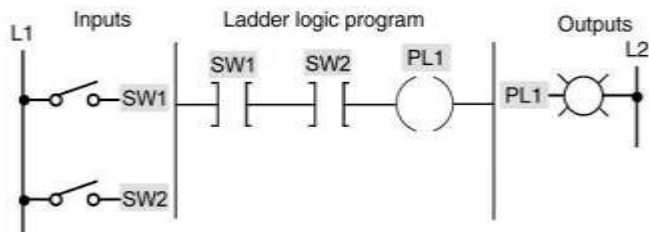

**Figure 2-16 Program for assignment 3.**

**Answers will vary according to the PLC used.**

4. (a) Program your controller to operate according to Figure 2-17.
- (b) Download the program to the PLC
- (c) Run the program and observe the status of the bits stored in the input and output image tables.

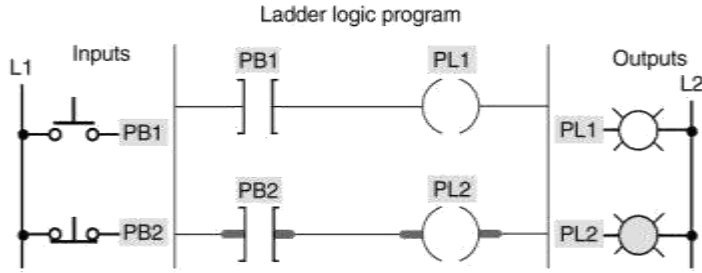

**Figure 2-17 Program for assignment 4.**

**Answers will vary according to the PLC used.**

5. (a) Program your controller to operate according to Figure 2-18.
- (b) Download the program to the PLC
- (c) Run the program and observe the status of the bits stored in the input and output image tables.

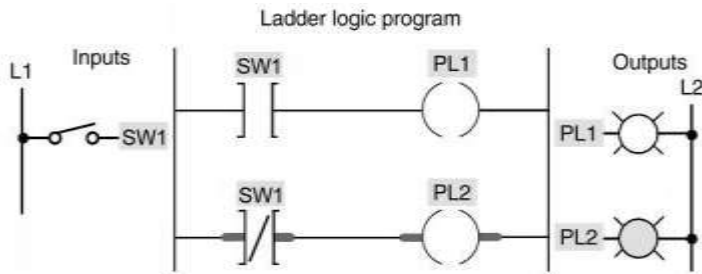
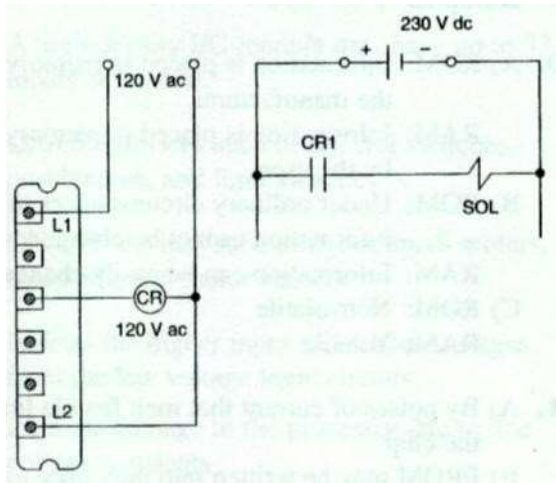

**Figure 2-18 Program for assignment 5.**

**Answers will vary according to the PLC used.**

## Answers to Chapter 1 Review Problems

1.



2. 35 mV
3. a) 0.012 s  
b) 0.00095 A  
c) 140°F
4. a) 11:12/05  
b) 00:20/07
5. The device would remain ON or energized at all times.
6. Programming software installed in the computer for each model of PLC to be programmed.