

Test Bank for Algebra and Trigonometry Graphs and Models 5th Edition Bittinger Beecher Ellenbogen Penna 9780321783974 0321783972

Full link download

Test Bank:

<https://testbankpack.com/p/test-bank-for-algebra-and-trigonometry-graphs-and-models-5th-edition-bittinger-beecher-ellenbogen-penna-9780321783974-0321783972/>

Solution Manual:

<https://testbankpack.com/p/solution-manual-for-algebra-and-trigonometry-graphs-and-models-5th-edition-bittinger-beecher-ellenbogen-penna-9780321783974-0321783972/>

MULTIPLE CHOICE. Choose the one alternative that best completes the statement or answers the question. Determine the intervals on which the function is increasing, decreasing, and constant.

1)

1) _____

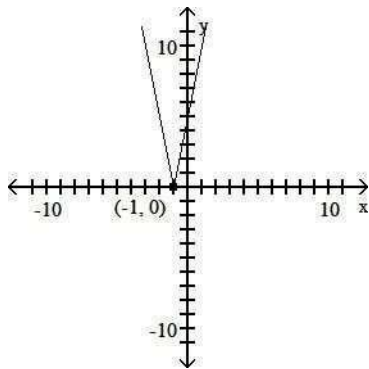

- A) Increasing on $(1, \infty)$; Decreasing on $(-\infty, 1)$
- B) Increasing on $(-\infty, -1)$; Decreasing on $(-1, \infty)$
- C) Increasing on $(-\infty, 1)$; Decreasing on $(1, \infty)$
- D) Increasing on $(-1, \infty)$; Decreasing on $(-\infty, -1)$

2)

2) _____

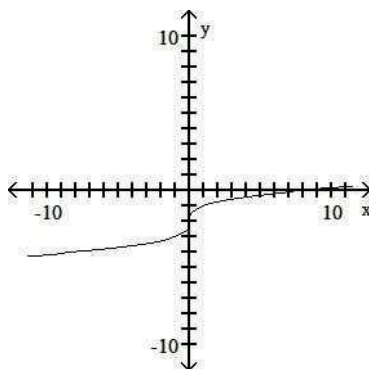

- A) Increasing on $(0, \infty)$; Decreasing on $(-\infty, 0)$
- B) Decreasing on $(-\infty, \infty)$
- C) Increasing on $(-\infty, \infty)$
- D) Increasing on $(-\infty, 0)$; Decreasing on $(0, \infty)$

3)

3) _____

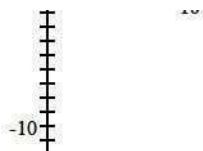

A) Increasing on $(4, \infty)$; Decreasing on $(-\infty, -4)$; Constant on $(-4, 4)$

- B) Increasing on $(-\infty, 4)$; Decreasing on $(-\infty, -4)$; Constant on $(4, \infty)$
- C) Increasing on $(4, \infty)$; Decreasing on $(-\infty, -4)$; Constant on $(-4, 4)$
- D) Increasing on $(-\infty, 4)$; Decreasing on $(-4, \infty)$; Constant on $(4, \infty)$

4)

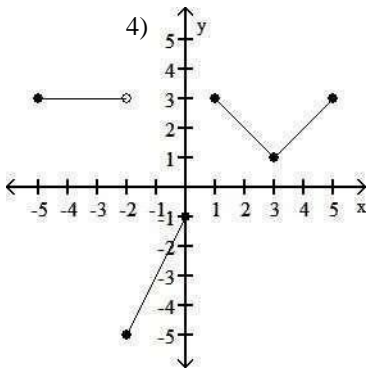

—
—
—
—

- A) Increasing on (1, 3); Decreasing on (-2, 0) and (3, 5); Constant on (2, 5)
- B) Increasing on (-2, 0) and (3, 5); Decreasing on (1, 3); Constant on (-5, -2)
- C) Increasing on (-2, 0) and (3, 4); Decreasing on (-5, -2) and (1, 3)
- D) Increasing on (-1, 0) and (3, 5); Decreasing on (0, 3); Constant on (-5, -3)

5)

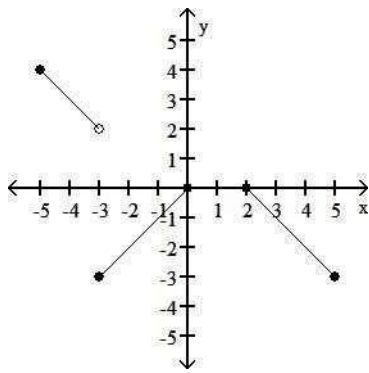

5) _____

- A) Increasing on (-5, -3) and (2, 5); Decreasing on (-3, 0); Constant on (0, 2)
- B) Increasing on (-3, -1); Decreasing on (-5, -2) and (2, 4); Constant on (-1, 2)
- C) Increasing on (-3, 0); Decreasing on (-5, -3) and (2, 5); Constant on (0, 2)
- D) Increasing on (-3, 1); Decreasing on (-5, -3) and (0, 5); Constant on (1, 2)

Determine the domain and range of the function.

6)

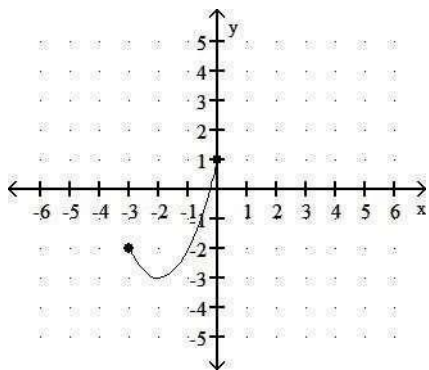

6) _____

- A) domain: [-3, 0]; range: [-3, 1]
- B) domain: $(-\infty, 1]$; range: [0, 3]
- C) domain: [0, 3]; range: $(-\infty, 1]$
- D) domain: [-3, 1]; range: [-3, 0]

7)

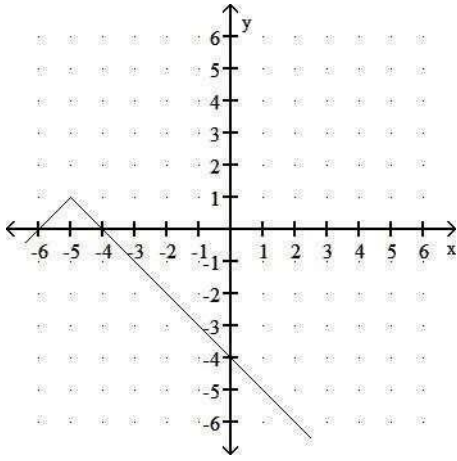

—
—
—

—

- A) domain: $(-\infty, \infty)$; range: $(-\infty, 1]$
- B) domain: $(-\infty, -5) \cup (-5, \infty)$; range: $(-\infty, 1) \cup (1, \infty)$
- C) domain: $(-\infty, -5]$; range: $(-\infty, 1]$
- D) domain: $(-\infty, \infty)$; range: $(-\infty, \infty)$

8)

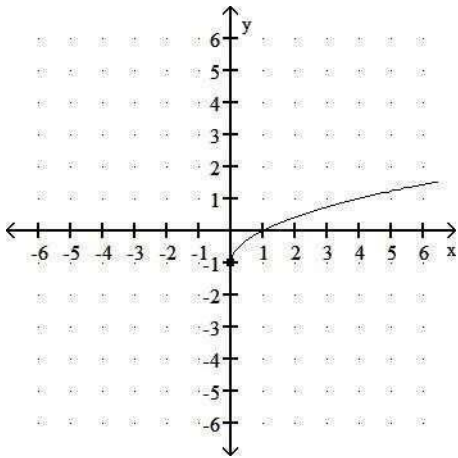

8) _____

- A) domain: $[0, \infty)$; range: $(-\infty, \infty)$
- B) domain: $[0, \infty)$; range: $[0, \infty)$
- C) domain: $[0, \infty)$; range: $[-1, \infty)$
- D) domain: $(-\infty, \infty)$; range: $[-1, \infty)$

9)

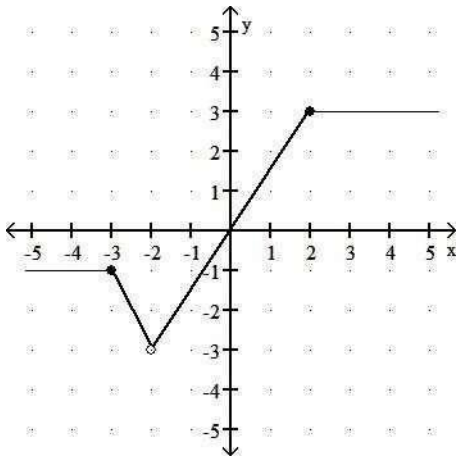

9) _____

- A) domain: $(-3, 3]$; range: $(-\infty, \infty)$
- B) domain: $(-\infty, \infty)$; range: $[-3, 3]$
- C) domain: $(-\infty, \infty)$; range: $[-3, 3]$
- D) domain: $(-\infty, \infty)$; range: $(-3, 3]$

10)

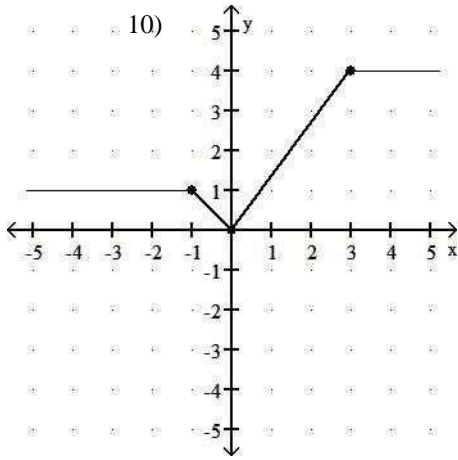

—
—

- A) domain: $[0, 4]$; range: $(-\infty, \infty)$
 C) domain: $(-\infty, \infty)$; range: $[0, 4]$

- B) domain: $(-\infty, \infty)$; range: $(0, 4)$
 D) domain: $(0, 4)$; range: $(-\infty, \infty)$

11)

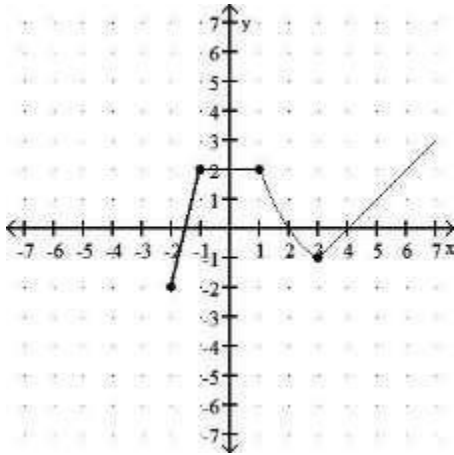

11) _____

- A) domain: $[-2, 2]$; range: $[-2, \infty)$
 C) domain: $[-2, \infty)$; range: $[-2, 2]$

- B) domain: $[-2, \infty)$; range: $[-2, \infty)$
 D) domain: $(-2, \infty)$; range: $(-2, \infty)$

12)

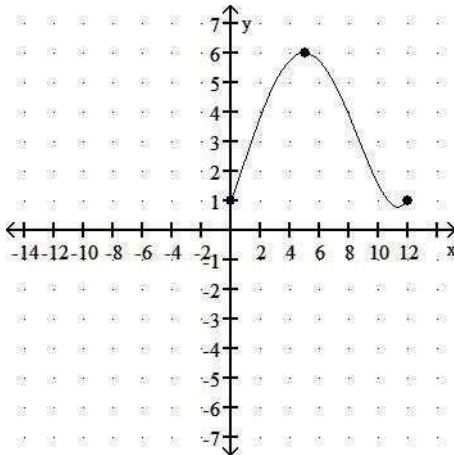

12) _____

- A) domain: $[0, 12]$; range: $[1, 6]$
 C) domain: $[1, 6]$; range: $[0, 12]$

- B) domain: $(1, 6)$; range: $(0, 12)$
 D) domain: $(0, 12)$; range: $(1, 6)$

Using the graph, determine any relative maxima or minima of the function and the intervals on which the function is increasing or decreasing. Round to three decimal places when necessary.

13) $f(x) = \sqrt{2} - 6x + 7$

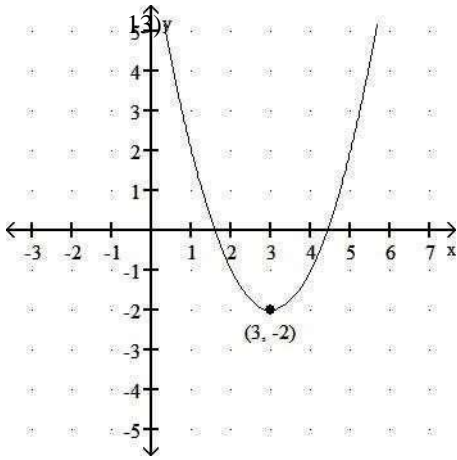

- A) relative minimum: 3 at $y = -2$; increasing $(-\infty, 3)$; decreasing $(3, \infty)$
- B) relative maximum: -2 at $x = 3$; increasing $(3, \infty)$; decreasing $(-\infty, 3)$
- C) relative maximum: 3 at $y = -2$; increasing $(-\infty, 3)$; decreasing $(3, \infty)$
- D) relative minimum: -2 at $x = 3$; increasing $(3, \infty)$; decreasing $(-\infty, 3)$

14) $f(x) = x^3 - 3x^2 + 1$

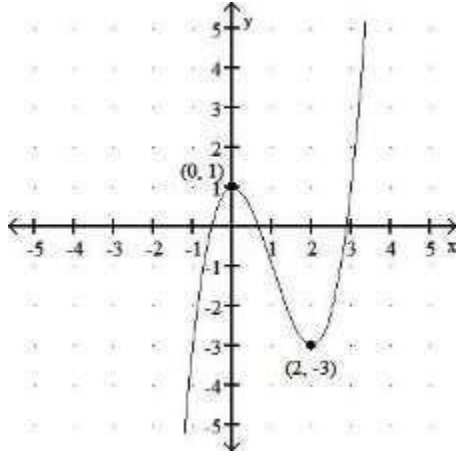

- A) relative maximum: 1 at $x = 0$; no relative minima; increasing $(-\infty, 0), (2, \infty)$; decreasing $(0, 2)$
- B) relative maximum: 1 at $x = 0$; relative minimum: -3 at $x = 2$; increasing $(-\infty, 0), (2, \infty)$; decreasing $(0, 2)$
- C) no relative maxima; relative minimum: -3 at $x = 2$; increasing $(-\infty, 0), (2, \infty)$; decreasing $(0, 2)$
- D) relative maximum: -3 at $x = 2$; relative minimum: 1 at $x = 0$; increasing $(0, 2)$; decreasing $(-\infty, 0), (2, \infty)$

15) $f(x) = x^3 - 12x + 2$

14) _____

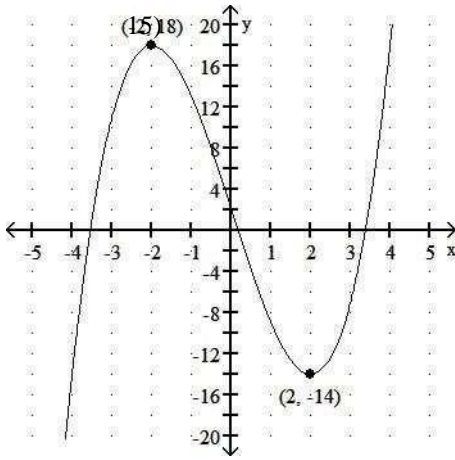

- A) relative maxima: 18 at $x = -2$ and 0 at $x = 0$; relative minimum: -14 at $x = 2$; increasing $(-\infty, -2), (2, \infty)$; decreasing $(-2, 2)$
- B) relative maximum: 18 at $x = -2$; relative minimum: -14 at $x = 2$; increasing $(-\infty, -2), (2, \infty)$; decreasing $(-2, 2)$
- C) no relative maxima or minima; increasing $(-\infty, -2), (2, \infty)$; decreasing $(-2, 2)$
- D) relative maximum: -14 at $x = 2$; relative minimum: 18 at $x = -2$; increasing $(-2, 2)$; decreasing $(-\infty, -2), (2, \infty)$

16)

$$f(x) = \frac{1}{2}x^3 + \frac{1}{2}x^2 - x + 1$$

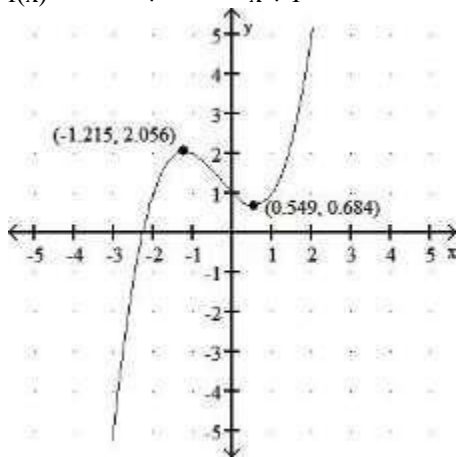

- A) no relative maxima or minima; increasing $(-\infty, -1.215), (0.549, \infty)$; decreasing $(-1.215, 0.549)$
- B) relative maximum: 2.056 at $x = -1.215$; relative minima: 0.684 at $x = 0.549$ and 1 at $x = 0$; increasing $(-1.215, 0.549)$ decreasing $(-\infty, -1.215), (0.549, \infty)$
- C) relative maximum: 2.056 at $x = -1.215$; relative minimum: 0.684 at $x = 0.549$; increasing $(-\infty, -1.215), (0.549, \infty)$; decreasing $(-1.215, 0.549)$
- D) relative maximum: 0.684 at $x = 0.549$; relative minimum: 2.056 at $x = -1.215$; increasing $(-1.215, 0.549)$ decreasing $(-\infty, -1.215), (0.549, \infty)$

17) $f(x) = -0.06x^3 - 0.3x^2 + 0.1x + 3$

16) _____

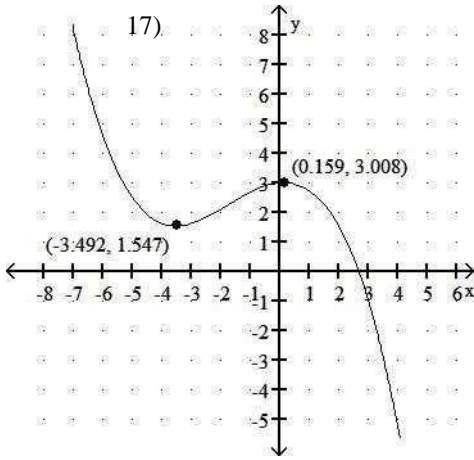

—
—

- A) relative maximum: 1.547 at $x = -3.492$; relative minimum: 3.008 at $x = 0.159$; increasing $(-3.492, 0.159)$ decreasing $(-\infty, -3.492), (0.159, \infty)$
- B) no relative maxima or minima; increasing $(-\infty, -3.492), (0.159, \infty)$; decreasing $(-3.492, 0.159)$
- C) relative maximum: 3.008 at $x = 0.159$; relative minimum: 1.547 at $x = -3.492$; increasing $(-3.492, 0.159)$ decreasing $(-\infty, -3.492), (0.159, \infty)$
- D) relative maxima: 3 at $x = 0$ and 3.008 at $x = 0.159$; relative minimum: 1.547 at $x = -3.492$; increasing $(-\infty, -3.492), (0.159, \infty)$; decreasing $(-3.492, 0.159)$

Graph the function. Use the graph to find any relative maxima or minima.

18) $f(x) = x^2 - 2$

18) _____

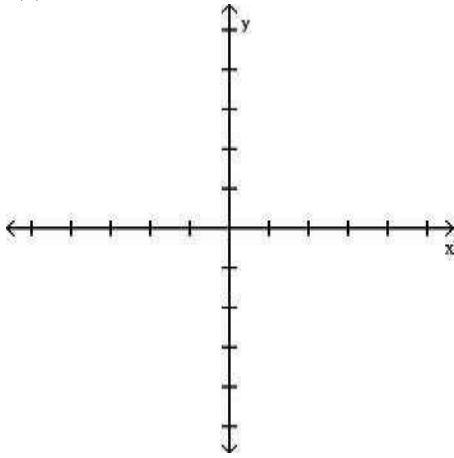

- A) Relative minimum of - 2 at $x = 0$
- B) Relative minimum of - 2 at $x = 1$
- C) Relative maximum of - 2 at $x = 0$
- D) No relative extrema

19) $f(x) = -x^2 + 3$

19)

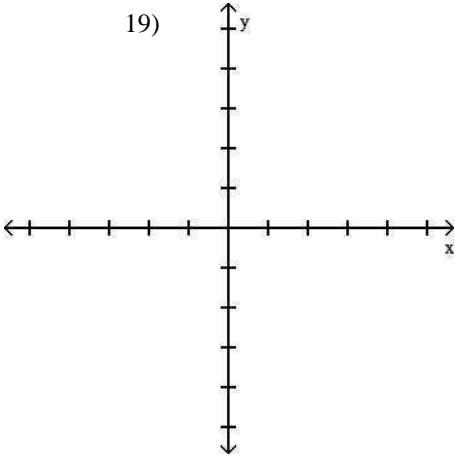

—
—

- A) No relative extrema
- B) Relative minimum of 3 at $x = 0$
- C) Relative maximum of 3 at $x = 0$
- D) Relative maximum of 3 at $x = 0$ and relative minimum at $x = 3$

20) $f(x) = -x^2 + 6x - 8$

20) _____

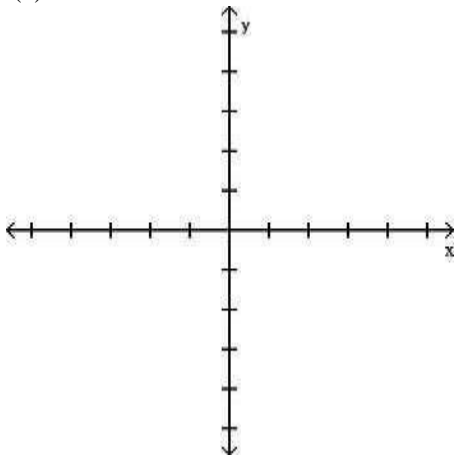

- A) Relative minimum of 1 at $x = 3$
- C) Relative maximum of 3 at $x = 1$

- B) No relative extrema
- D) Relative maximum of 1 at $x = 3$

21) $f(x) = x^2 + 8x + 13$

21) _____

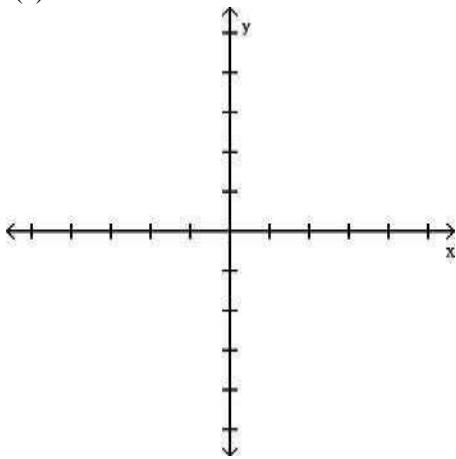

- A) Relative minimum of -3 at $x = -4$
- C) Relative maximum of -3 at $x = -4$

- B) Relative maximum of -3.2 at $x = -4.1$
- D) Relative minimum of -3.2 at $x = -4.1$

22) $f(x) = 1 - |x|$

22) _____

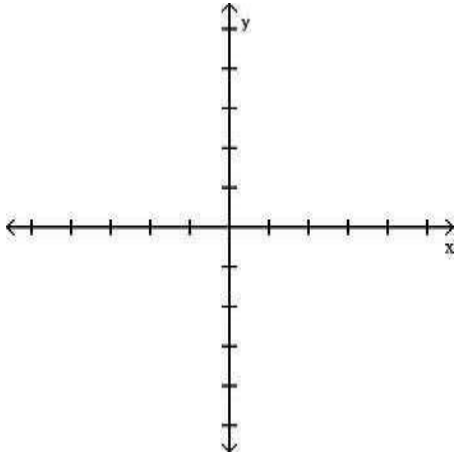

- A) No relative extrema
 B) Relative maximum of 1 at $x = 0$
 C) Relative minimum of 1 at $x = 0$
 D) Relative maximum of 1.5 at $x = 0$

23) $f(x) = |x + 3| - 4$

23) _____

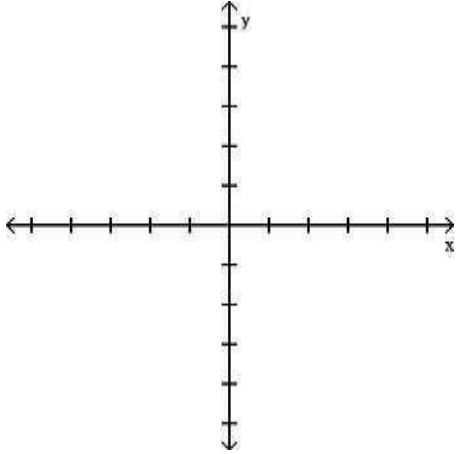

- A) Relative minimum of -4 at $x = -3$
 B) Relative minimum of 3.7 at $x = -3$
 C) Relative maximum of 4 at $x = -3$
 D) Relative minimum of 4.2 at $x = -3$

Solve.

24) Elissa wants to set up a rectangular dog run in her backyard. She has 20 feet of fencing to work with and wants to use it all. If the dog run is to be x feet long, express the area of the dog run as a function of x . 24) _____

- A) $A(x) = 12x^2 - x$ B) $A(x) = 9x - x^2$ C) $A(x) = 11x - x^2$ D) $A(x) = 10x - x^2$

25) Bob wants to fence in a rectangular garden in his yard. He has 72 feet of fencing to work with and wants to use it all. If the garden is to be x feet wide, express the area of the garden as a function of x . 25) _____

- A) $A(x) = 35x - x^2$ B) $A(x) = 36x - x^2$ C) $A(x) = 38x - x^2$ D) $A(x) = 37x - x^2$

26) A rocket is shot straight up in the air from the ground at a rate of 67 feet per second. The rocket is tracked by a rangefinder that is 426 feet from the launch pad. Let d represent the distance from the rocket to the rangefinder and t represent the time, in seconds, since "blastoff". Express d as a function of t . 26) _____

- A) $d(t) = \sqrt{426^2 + (67t)^2}$ B) $d(t) = \sqrt{67^2 + (426t)^2}$
 C) $d(t) = \sqrt{426^2 + (67t)^2}$ D) $d(t) = 426 + 67t$

27) Sue wants to put a rectangular garden on her property using 62 meters of fencing. There is a river that runs through her property so she decides to increase the size of the garden by using the river as one side of the rectangle. (Fencing is then needed only on the other three sides.) Let x represent the length of the side of the rectangle along the river. Express the garden's area as a function of x .

A) $A(x) = 32x - 2x^2$

B) $A(x) = 30x - \frac{1}{4}x^2$

C) $A(x) = 31x^2 - x$

D) $A(x) = 31x - \frac{1}{2}x^2$

27) _____

28) A farmer's silo is the shape of a cylinder with a hemisphere as the roof. If the height of the silo is 115 feet and the radius of the hemisphere is r feet, express the volume of the silo as a function of r .

A) $V(r) = \pi(115 - r)r^3 + \frac{4}{3}\pi r^3$

B) $V(r) = \pi(115 - r)r^2 + \frac{4}{3}\pi r^3$

C) $V(r) = \pi(115 - r)r^2 + \frac{2}{3}\pi r^3$

D) $V(r) = r^2 + \frac{8}{3}\pi r^3$

28) _____

29) A farmer's silo is the shape of a cylinder with a hemisphere as the roof. If the radius of the hemisphere is 10 feet and the height of the silo is h feet, express the volume of the silo as a function of h .

A) $V(h) = 100\pi h + \frac{4000}{3}\pi$

B) $V(h) = 100\pi(h - 10) + \frac{2000}{3}\pi$

C) $V(h) = 4100\pi(h - 10) + \frac{500}{3}\pi$

D) $V(h) = 100\pi(h^2 - 10) + \frac{5000}{3}\pi$

29) _____

30) A rectangular sign is being designed so that the length of its base, in feet, is 10 feet less than 4 times the height, h . Express the area of the sign as a function of h .

A) $A(h) = 10h - 2h^2$

B) $A(h) = -10h + 4h^2$

C) $A(h) = -10h^2 + 2h$

D) $A(h) = -10h + h^2$

30) _____

31) From a 40-inch by 40-inch piece of metal, squares are cut out of the four corners so that the sides can then be folded up to make a box. Let x represent the length of the sides of the squares, in inches, that are cut out. Express the volume of the box as a function of x .

A) $V(x) = 2x^3 - 120x^2 + 40x$

B) $V(x) = 4x^3 - 160x^2 + 1600x$

C) $V(x) = 4x^3 - 160$

D) $V(x) = 2x^3 - 120$

31) _____

32) A rectangular box with volume 469 cubic feet is built with a square base and top. The cost is \$1.50 per square foot for the top and the bottom and \$2.00 per square foot for the sides. Let x represent the length of a side of the base. Express the cost the box as a function of x .

A) $C(x) = 2x^2 + \frac{3752}{x}$

B) $C(x) = 3x^2 + \frac{1876}{x}$

C) $C(x) = 4x + \frac{3752}{x^2}$

D) $C(x) = 3x^2 + \frac{3752}{x}$

32) _____

33) A rectangle that is x feet wide is inscribed in a circle of radius 34 feet. Express the area of the rectangle as a function of x .

33) _____

A) $A(x) = x(4624 - x^2)$

B) $A(x) = x\sqrt{3468 - x}$

C) $A(x) = x^2\sqrt{2312 - x^2}$

D) $A(x) = x\sqrt{4624 - x^2}$

- 34) From a 15-inch by 15-inch piece of metal, squares are cut out of the four corners so that the sides can then be folded up to make a box. Let x represent the length of the sides of the squares, in inches, that are cut out. Express the volume of the box as a function of x . Graph the function and from the graph determine the value of x , to the nearest tenth of an inch, that will yield the maximum volume. 34) _____
- A) 2.8 inches B) 3.1 inches C) 2.5 inches D) 2.3 inches
- 35) From a 24-inch by 24-inch piece of metal, squares are cut out of the four corners so that the sides can then be folded up to make a box. Let x represent the length of the sides of the squares, in inches, that are cut out. Express the volume of the box as a function of x . Graph the function and from the graph determine the value of x , to the nearest tenth of an inch, that will yield the maximum volume. 35) _____
- A) 3.7 inches B) 4.1 inches C) 4.0 inches D) 3.8 inches
- 36) A rectangular box with volume 468 cubic feet is built with a square base and top. The cost is \$1.50 per square foot for the top and the bottom and \$2.00 per square foot for the sides. Let x represent the length of a side of the base in feet. Express the cost of the box as a function of x and then graph this function. From the graph find the value of x , to the nearest hundredth of a foot, which will minimize the cost of the box. 36) _____
- A) 8.55 feet B) 8.63 feet C) 7.92 feet D) 8.44 feet
- 37) A rectangular box with volume 517 cubic feet is built with a square base and top. The cost is \$1.50 per square foot for the top and the bottom and \$2.00 per square foot for the sides. Let x represent the length of a side of the base in feet. Express the cost of the box as a function of x and then graph this function. From the graph find the value of x , to the nearest hundredth of a foot, which will minimize the cost of the box. 37) _____
- A) 8.49 feet B) 8.83 feet C) 8.79 feet D) 8.91 feet
- 38) A rectangle that is x feet wide is inscribed in a circle of radius 20 feet. Express the area of the rectangle as a function of x . Graph the function and from the graph determine the value of x , to the nearest tenth of a foot, which will maximize the area of the rectangle. 38) _____
- A) 28.7 feet B) 28.3 feet C) 29.1 feet D) 27.9 feet
- 39) A rectangle that is x feet wide is inscribed in a circle of radius 32 feet. Express the area of the rectangle as a function of x . Graph the function and from the graph determine the value of x , to the nearest tenth of a foot, which will maximize the area of the rectangle. 39) _____
- A) 45.7 feet B) 44.5 feet C) 44.9 feet D) 45.3 feet
- 40) Elissa sells two breeds of dogs, Alaskan Malamutes and Great Pyrenees. She has 102 feet of fencing to enclose two adjacent rectangular dog kennels, one for each breed. An existing fence is to form one side of the kennels, as in the drawing below. Suppose the total length of the two kennels is x feet. Express the total area of the two kennels as a function of x . Graph the function and from the graph determine the value of x that will yield the maximum area.

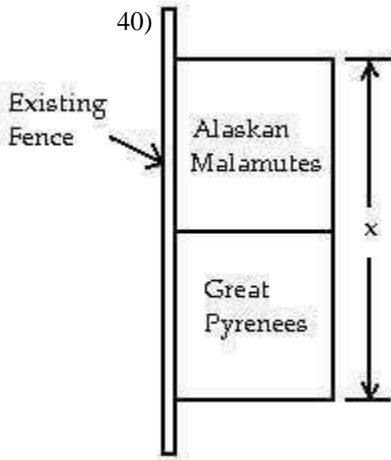

- A) 51 feet B) 50 feet C) 53 feet D) $51\frac{1}{2}$ feet

41) Elissa sells two breeds of dogs, Alaskan Malamutes and Great Pyrenees. She has 102 feet of fencing to enclose two adjacent rectangular dog kennels, one for each breed. An existing fence is to form one side of the kennels, as in the drawing below. Let x represent the measurement indicated. Express the total area of the two kennels as a function of x . Graph the function and from the graph determine the value of x , rounded to the hundredths place, that will yield the maximum area.

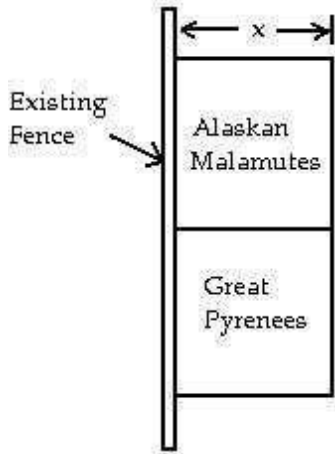

- A) 17.33 feet B) 25.50 feet C) 17.00 feet D) 17.17 feet

For the piecewise function, find the specified function value.

42) $f(x) = \begin{cases} 8x, & \text{for } x \leq -1, \\ x - 3, & \text{for } x > -1 \end{cases}$ 42) _____
 $f(-6)$
 A) - 48 B) 3 C) 48 D) - 9

43) $f(x) = \begin{cases} x - 6, & \text{for } x < 6, \\ 4 - x, & \text{for } x \geq 6 \end{cases}$ 43) _____
 $f(0)$
 A) - 6 B) -2 C) 0 D) 4

44) $f(x) = \begin{cases} 2x + 2, & \text{for } x \leq 0, \\ 3 - 5x, & \text{for } 0 < x < 5, \\ x, & \text{for } x \geq 5 \end{cases}$ $f(6)$ 44)

A) 14

B) 6

C) -27

D) 5

45)

$$f(x) = \begin{cases} 8x + 1, & \text{for } x < 1, \\ 5x, & \text{for } 5 \leq x \leq 10, \\ 5 - 5x, & \text{for } x > 10 \end{cases}$$

f(5)

A) 51

B) 25

C) -20

D) 9

45) _____

46)

$$f(x) = \begin{cases} 3x + 1, & \text{for } x < 3, \\ 3x, & \text{for } 3 \leq x \leq 8, \\ 3 - 2x, & \text{for } x > 8 \end{cases}$$

f(-3)

A) 10

B) -9

C) 9

D) -8

46) _____

Graph the function.

47)

$$f(x) = \begin{cases} -2, & \text{for } x \geq 1, \\ -4 - x, & \text{for } x < 1 \end{cases}$$

47) _____

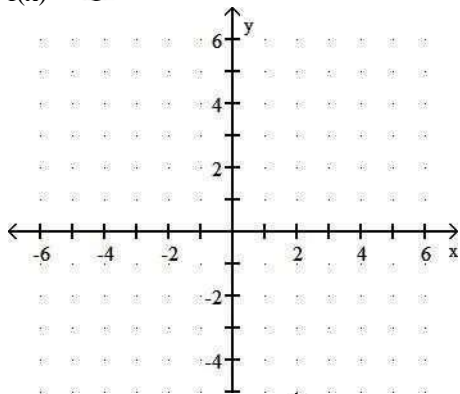

A)

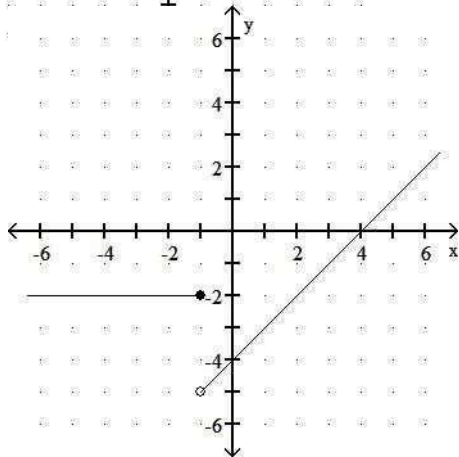

B)

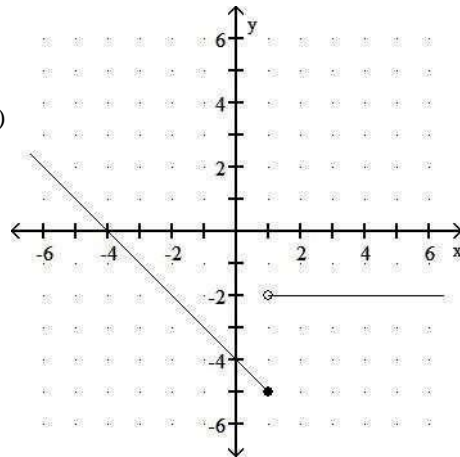

C)

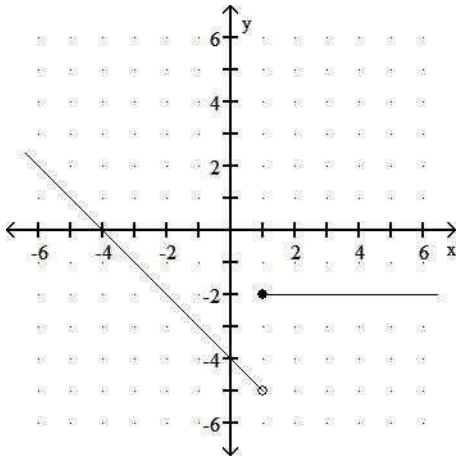

D)

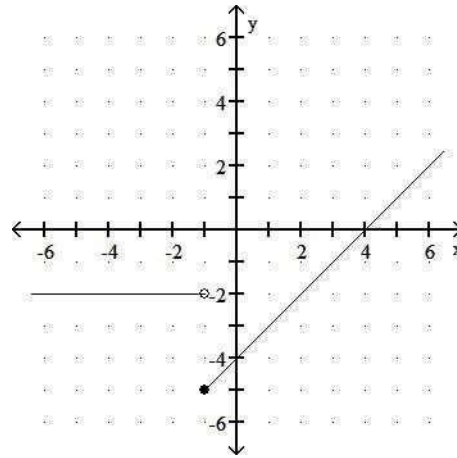

48) $f(x) = \begin{cases} x - 1, & \text{for } x > 0, \\ 5, & \text{for } x \leq 0 \end{cases}$

48) _____

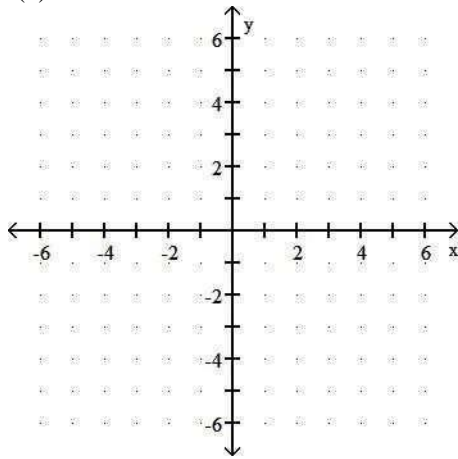

A)

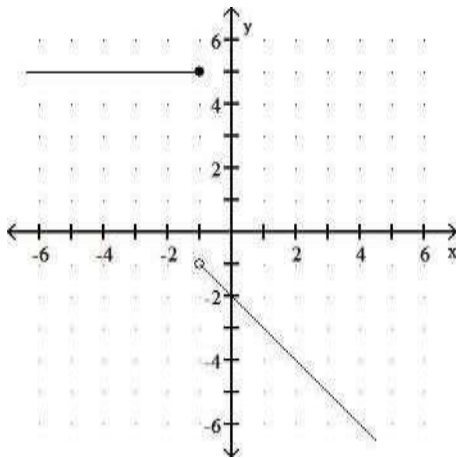

B)

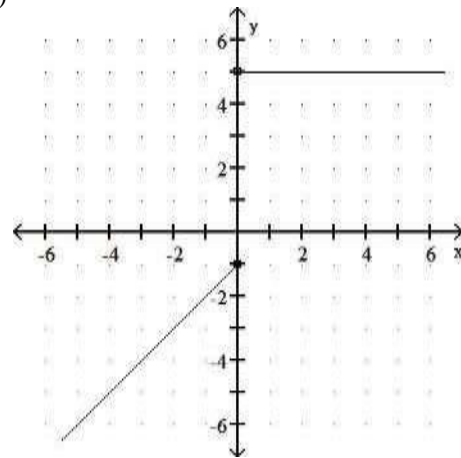

C)

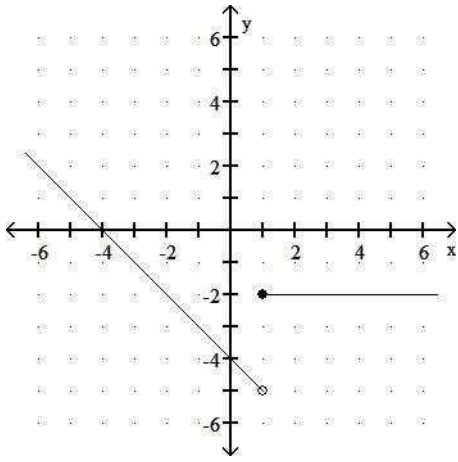

D)

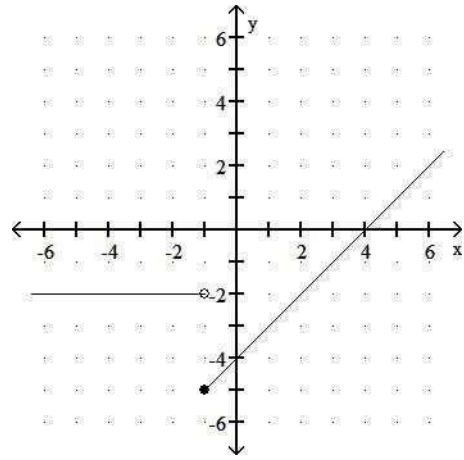

49)

$$f(x) = \begin{cases} 1 - x, & \text{for } x \leq 2, \\ 1 - 3x, & \text{for } x > 2 \end{cases}$$

49) _____

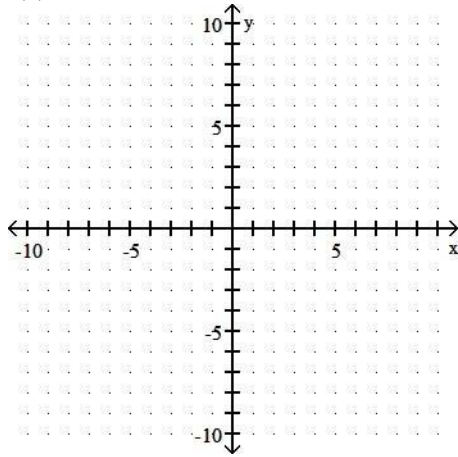

A)

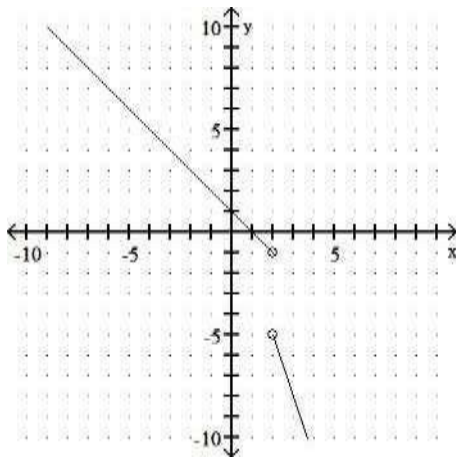

B)

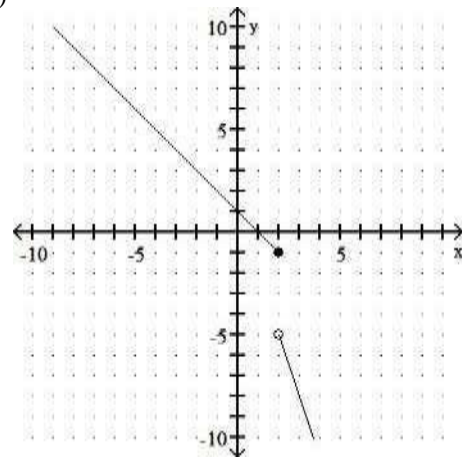

C)

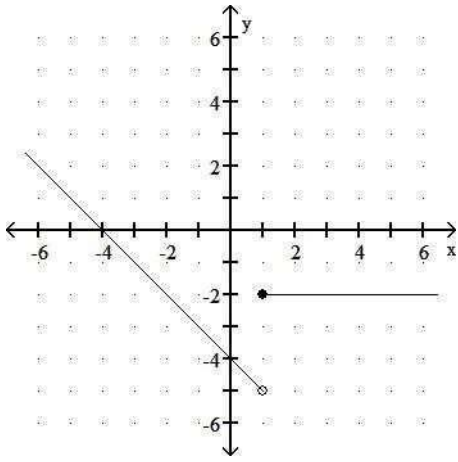

D)

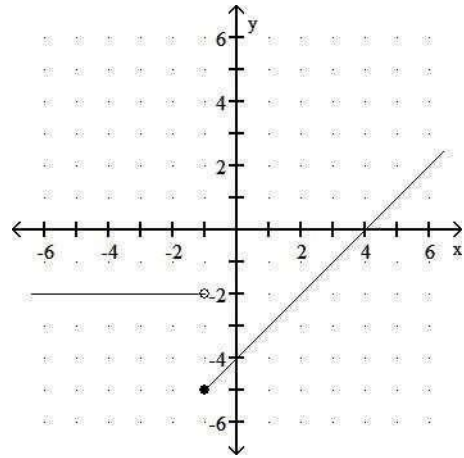

50)

$$f(x) = \begin{cases} x+2 & \text{for } -8 \leq x < 4 \\ -9 & \text{for } x = 4 \\ -x+5 & \text{for } x > 4 \end{cases}$$

50) _____

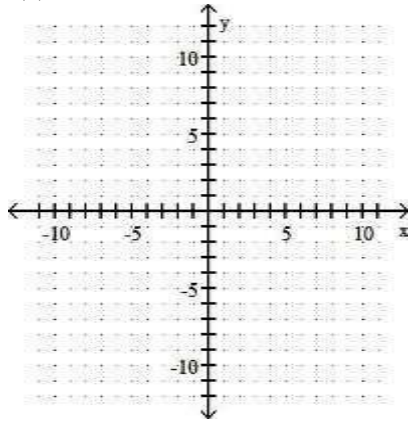

A)

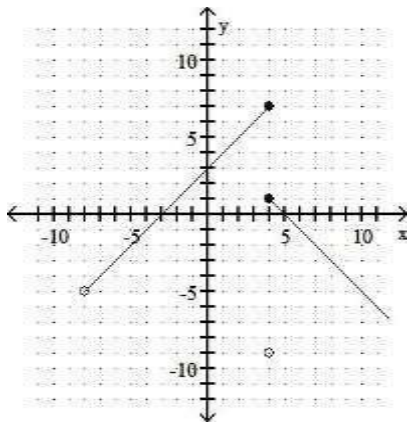

B)

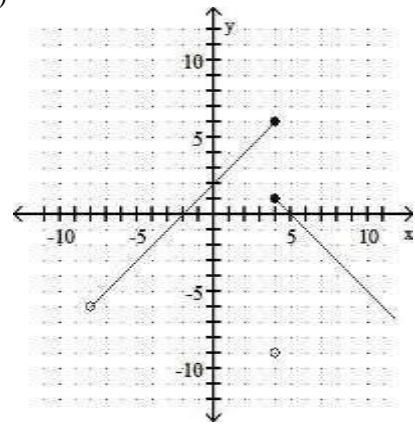

C)

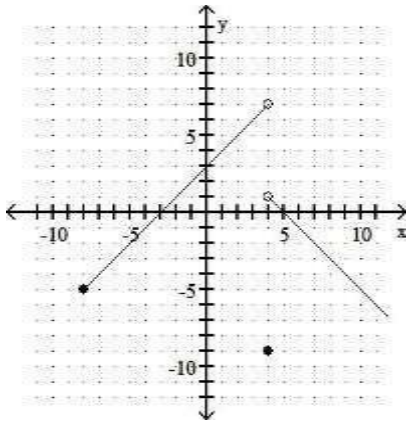

D)

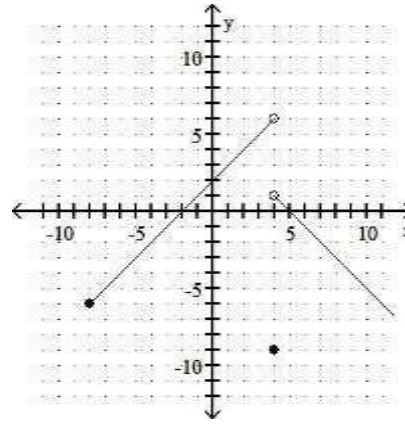

51)
$$f(x) = \begin{cases} 5x + 2 & \text{for } x < -2 \\ x & \text{for } -2 \leq x \leq 3 \\ 4x - 1 & \text{for } x > 3 \end{cases}$$

51) _____

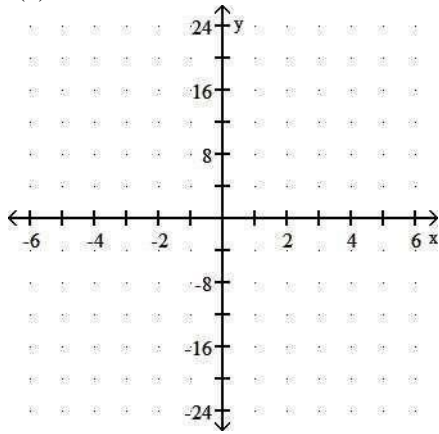

A)

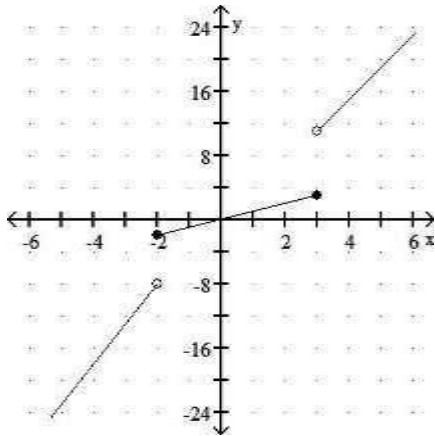

B)

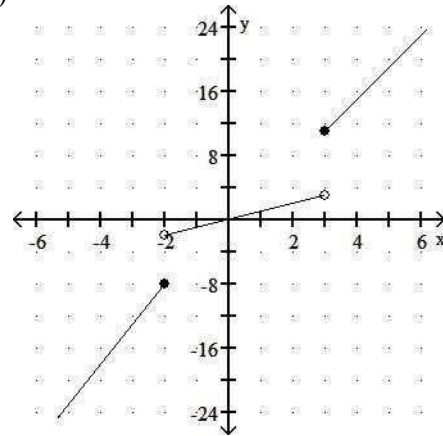

C)

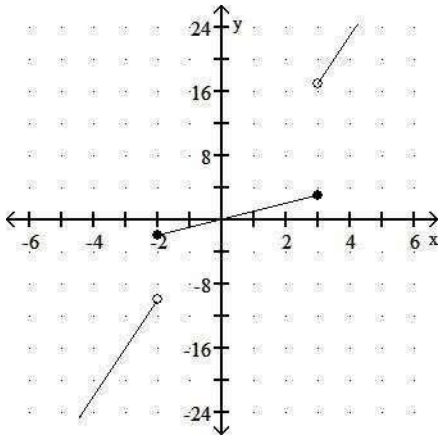

D)

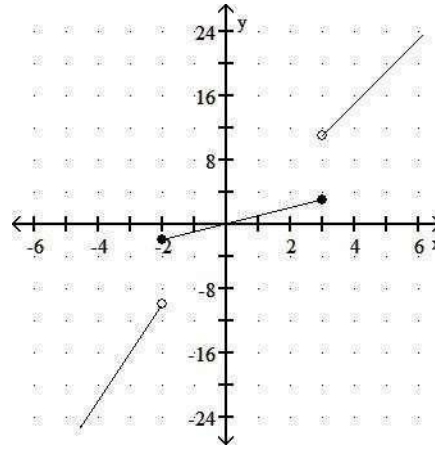

52)

$$f(x) = \begin{cases} \frac{1}{x+4}, & \text{for } x \neq -4, \\ 6, & \text{for } x = -4 \end{cases}$$

52) _____

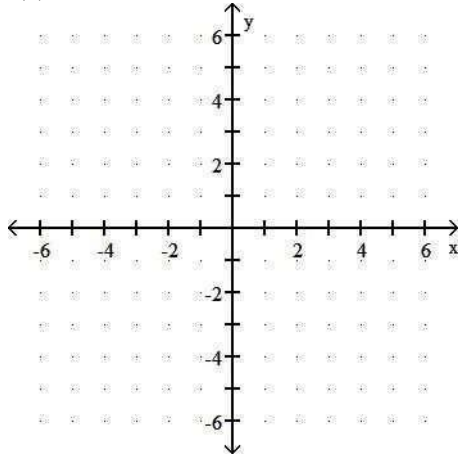

A)

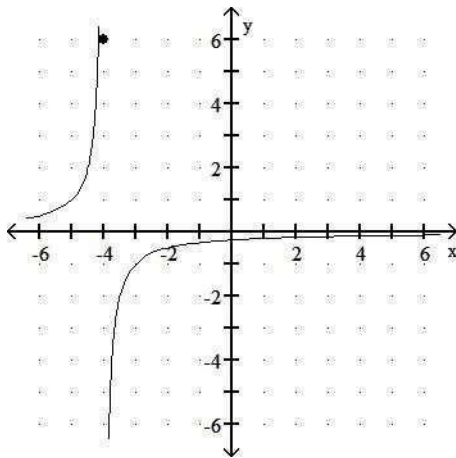

B)

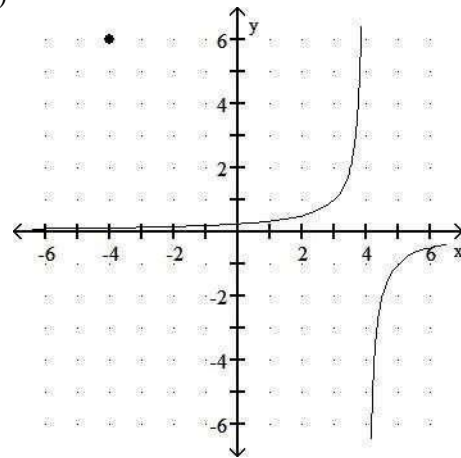

C)

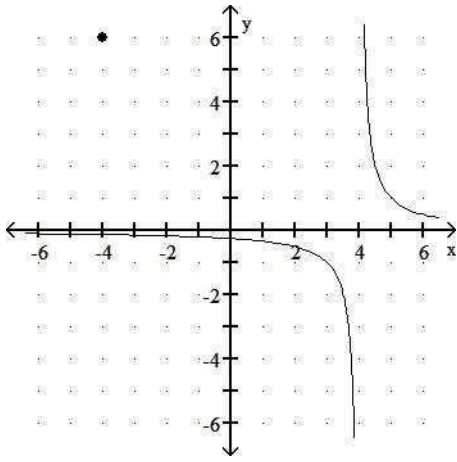

D)

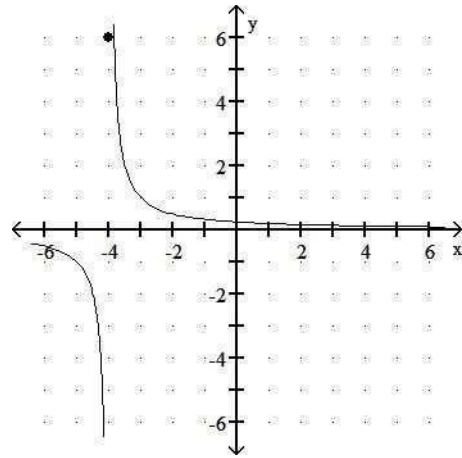

53)

$$f(x) = \begin{cases} \frac{x^2 - 1}{x + 1}, & \text{for } x \neq -1, \\ 2, & \text{for } x = -1 \end{cases}$$

53) _____

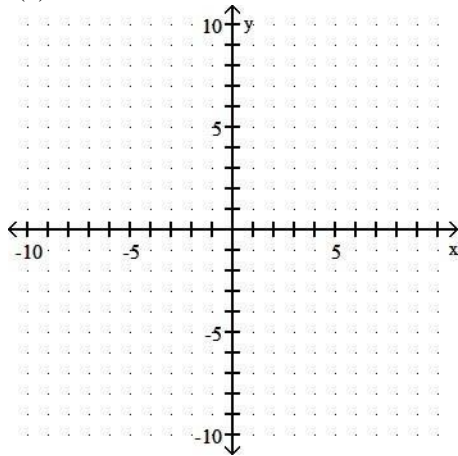

A)

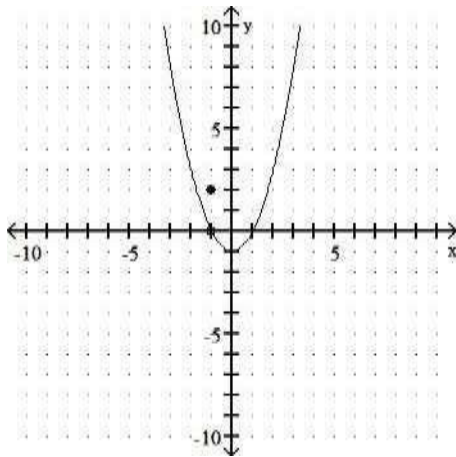

B)

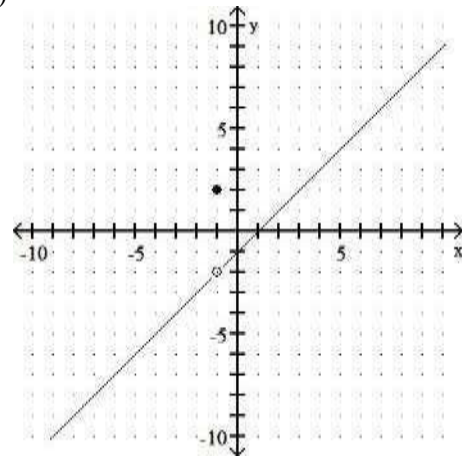

C)

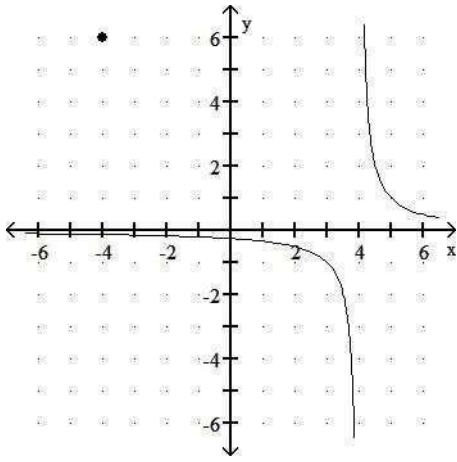

D)

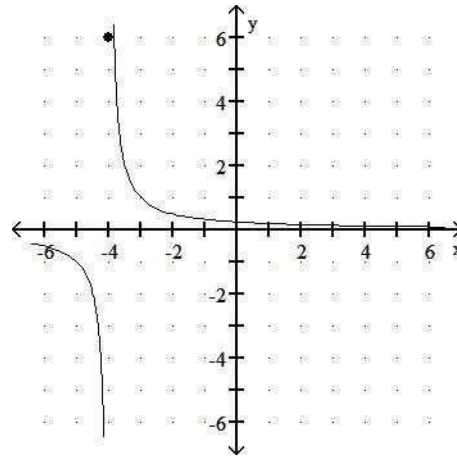

54)

$$f(x) = \begin{cases} \frac{x^2 - 9}{x - 3}, & \text{for } x \neq 3, \\ -7, & \text{for } x = 3 \end{cases}$$

54) _____

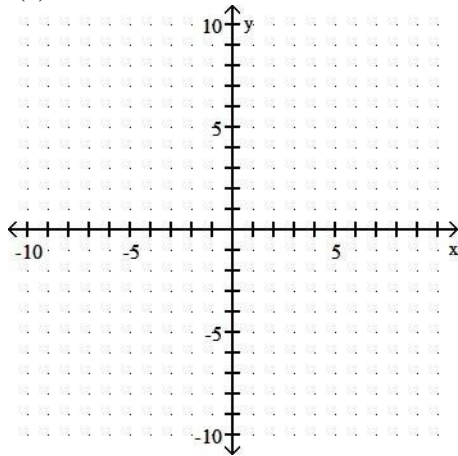

A)

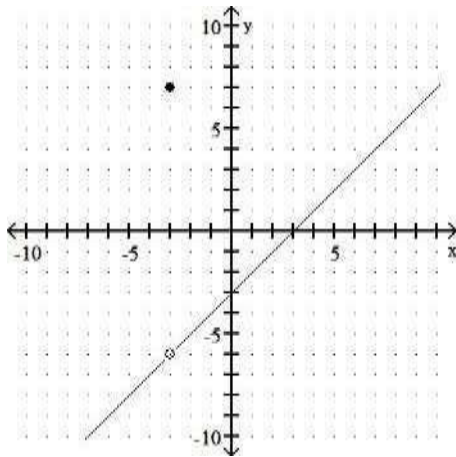

B)

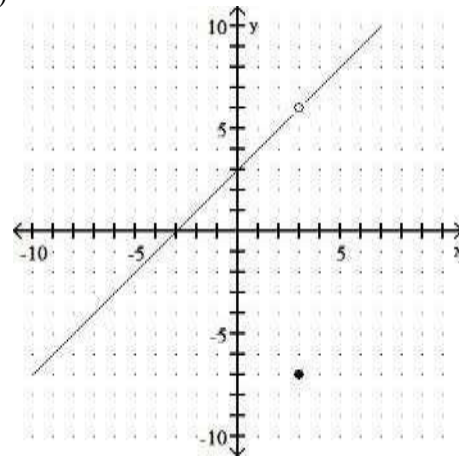

C)

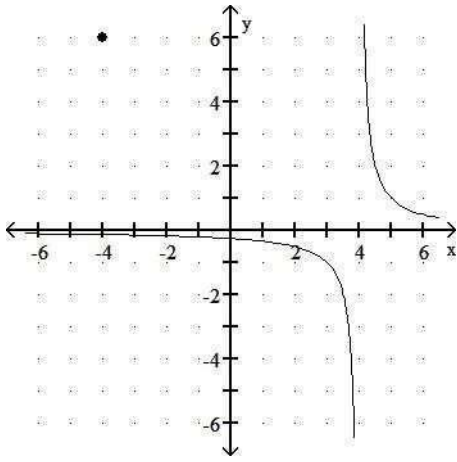

D)

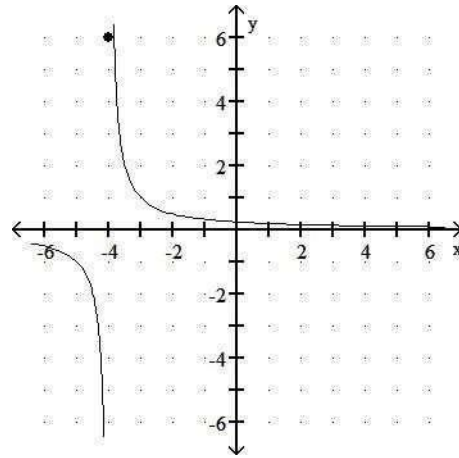

55)

$$f(x) = \begin{cases} \frac{x^2 + 7x + 10}{x + 2}, & \text{for } x \neq -2, \\ -5, & \text{for } x = -2 \end{cases}$$

55) _____

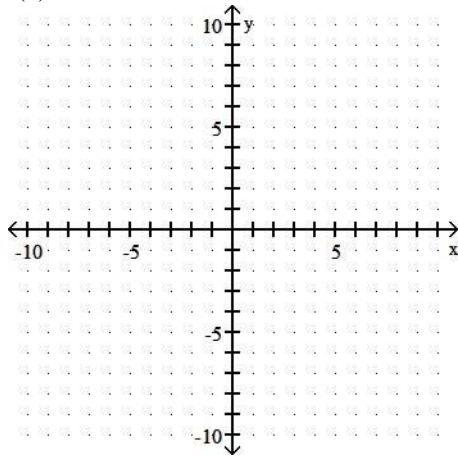

A)

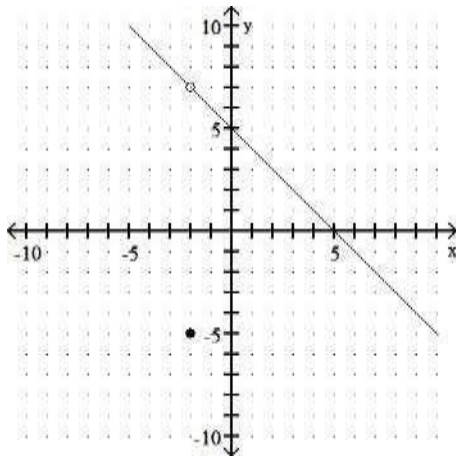

B)

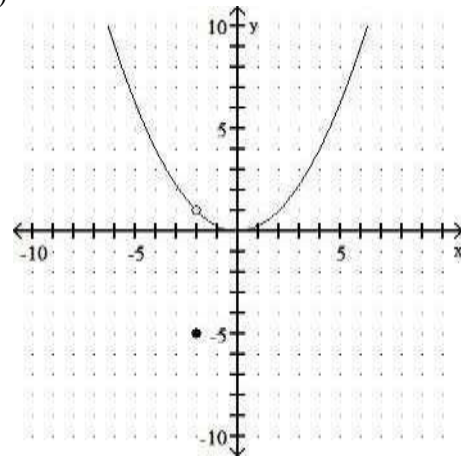

C)

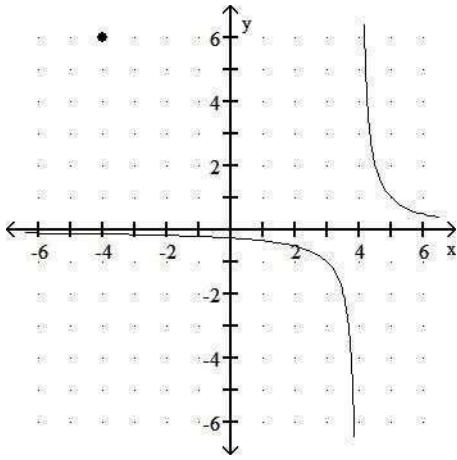

D)

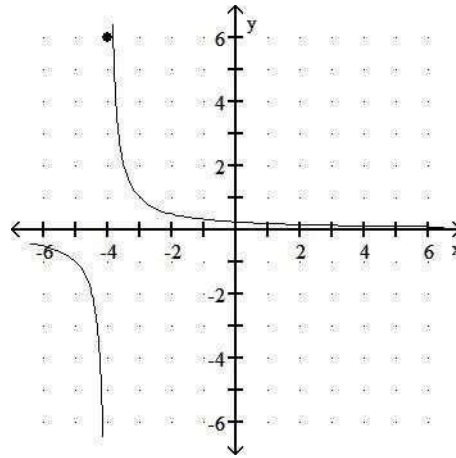

Graph the equation.

56) $y = \lfloor x \rfloor$

56) _____

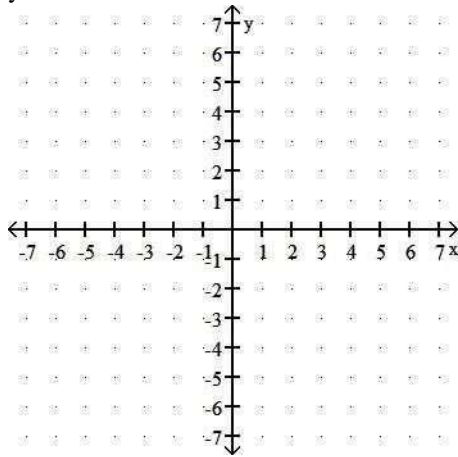

A)

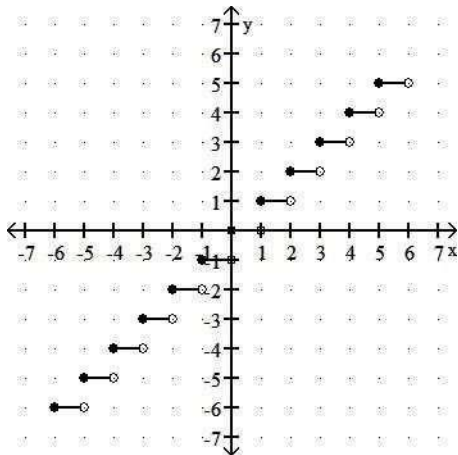

B)

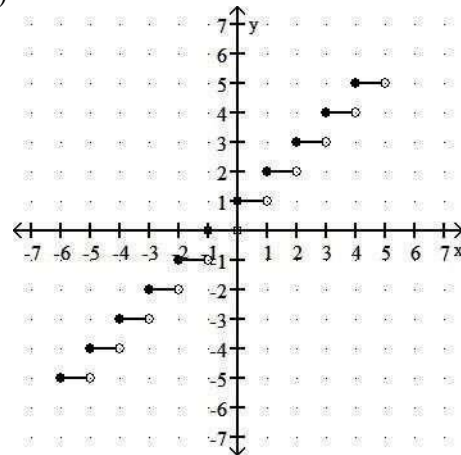

C)

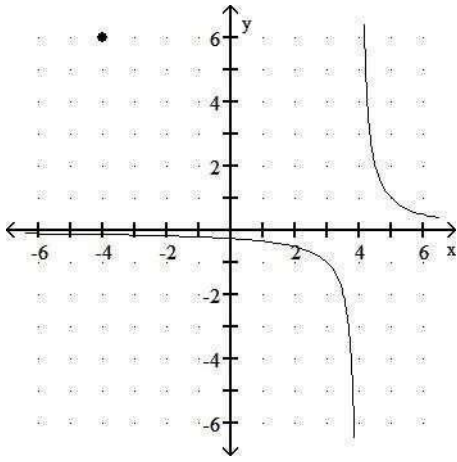

D)

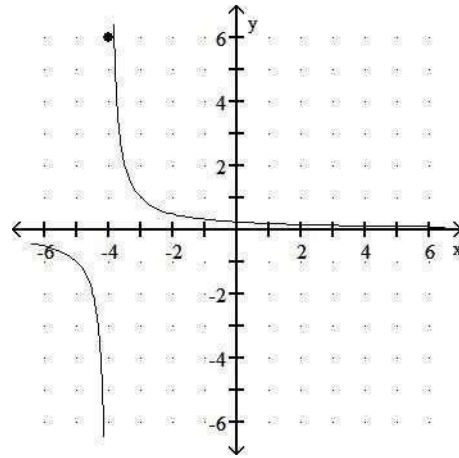

57) $y = \frac{1}{2} \lfloor \lfloor x \rfloor \rfloor$

57) _____

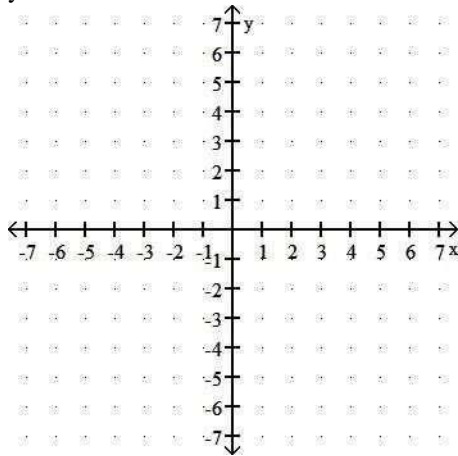

A)

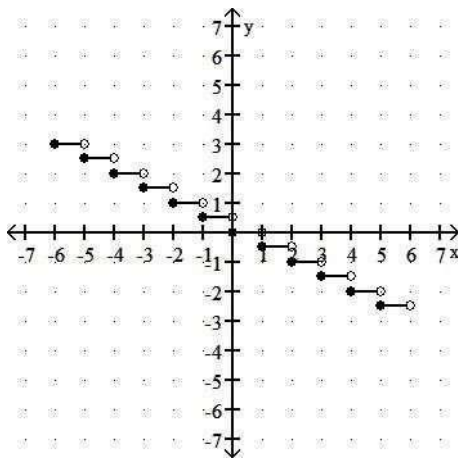

C)

B)

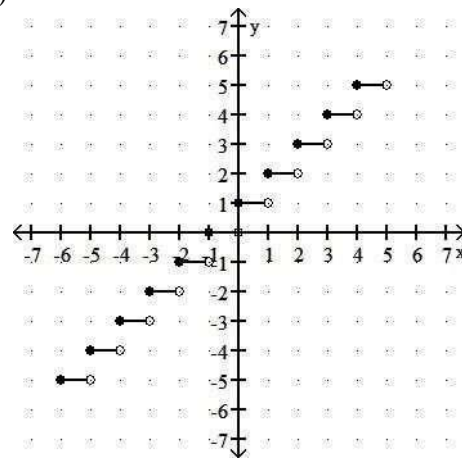

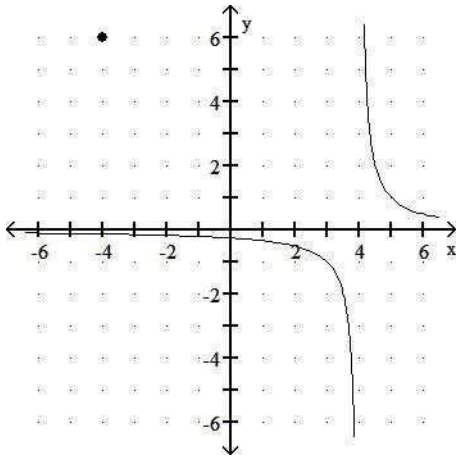

D)

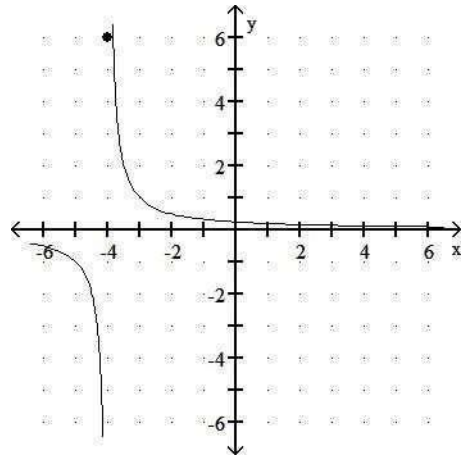

58) $y = 3 \lfloor x \rfloor$

58) _____

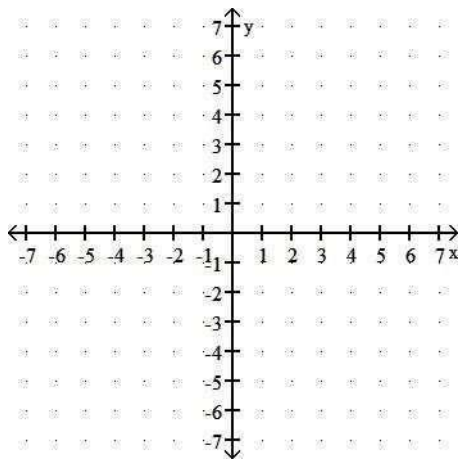

A)

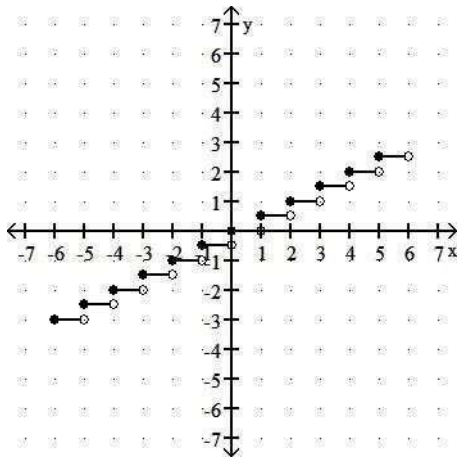

B)

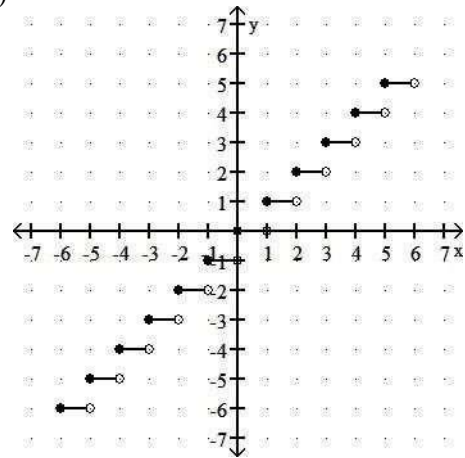

C)

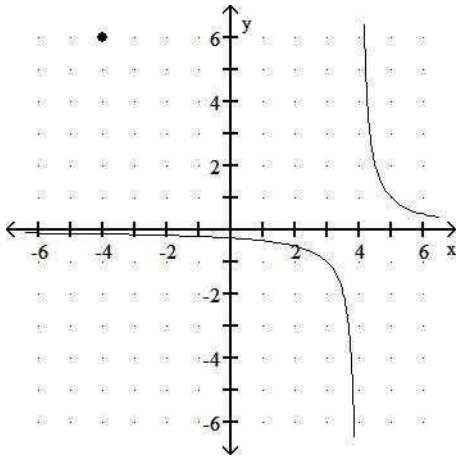

D)

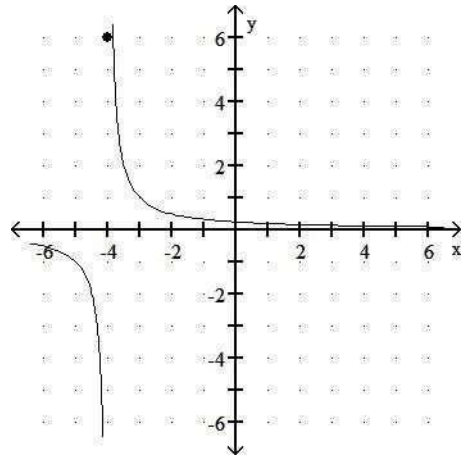

59) $y = 2 \lfloor x \rfloor$

59) _____

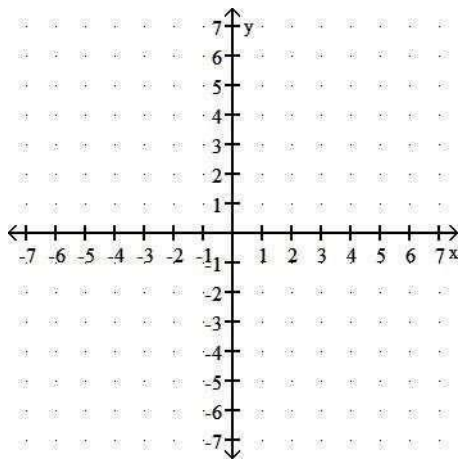

A)

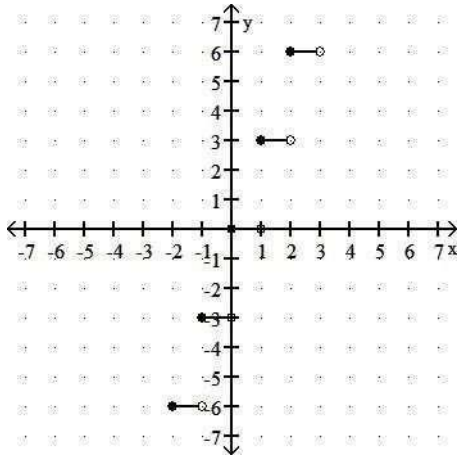

C)

B)

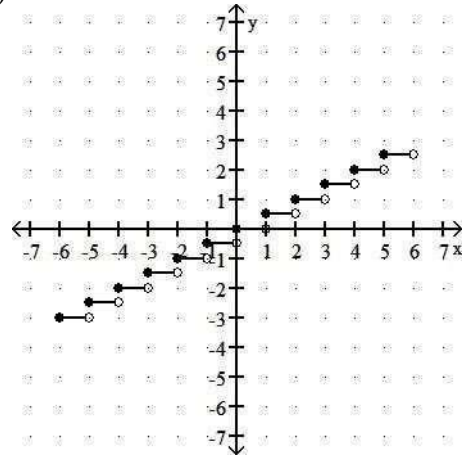

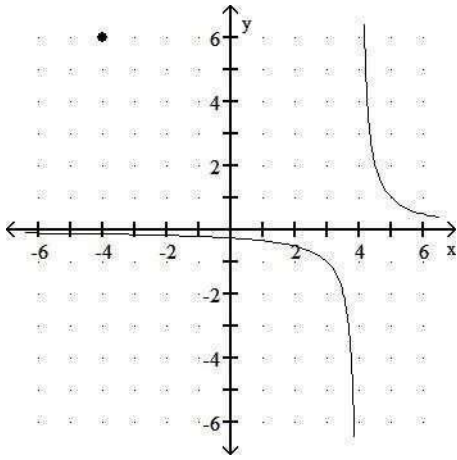

D)

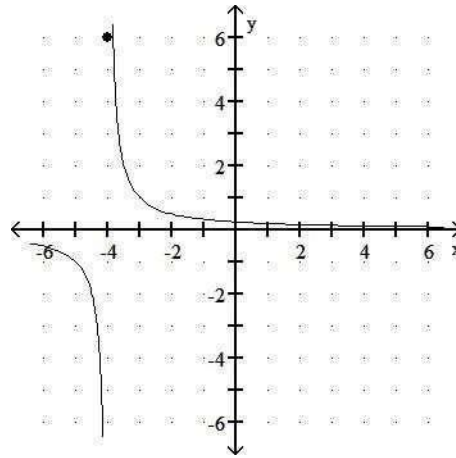

60) $y = 4 + \lfloor x \rfloor$

60) _____

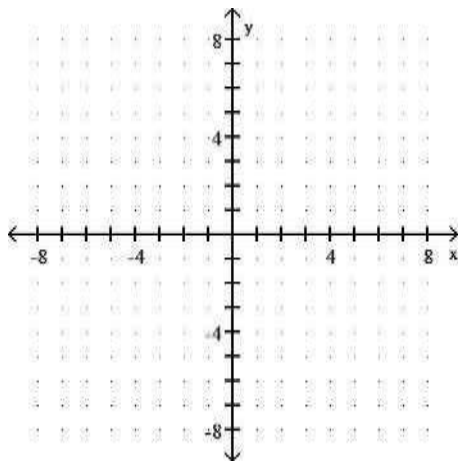

A)

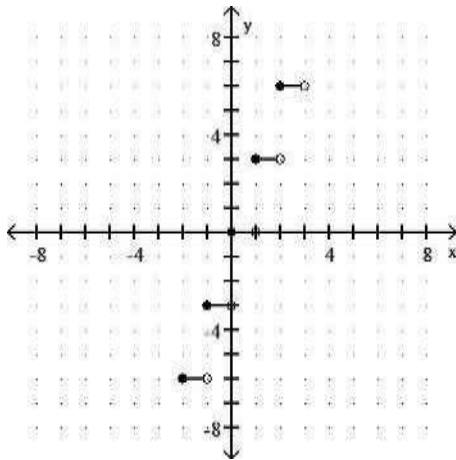

C)

B)

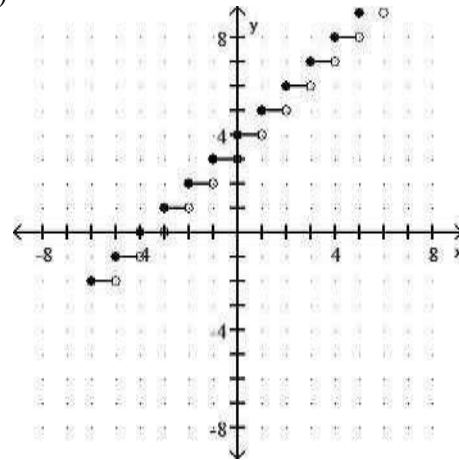

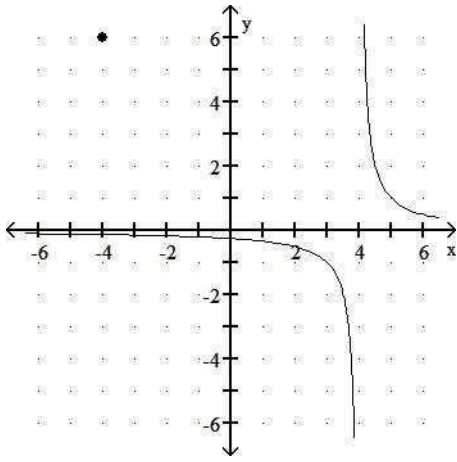

D)

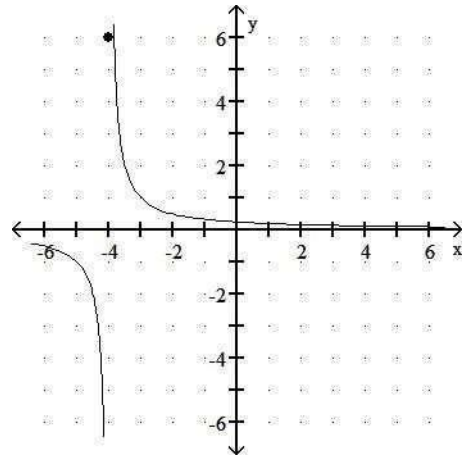

61) $y = \frac{1}{2} \lfloor \lfloor x \rfloor \rfloor - 4$

61) _____

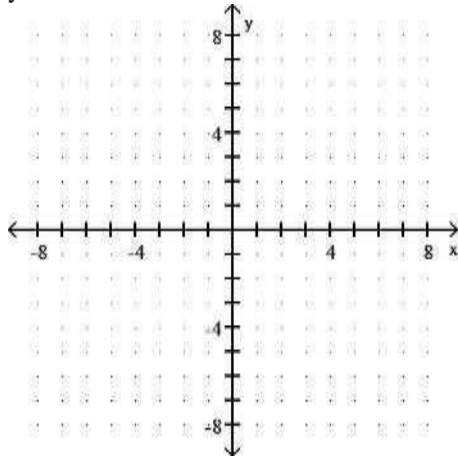

A)

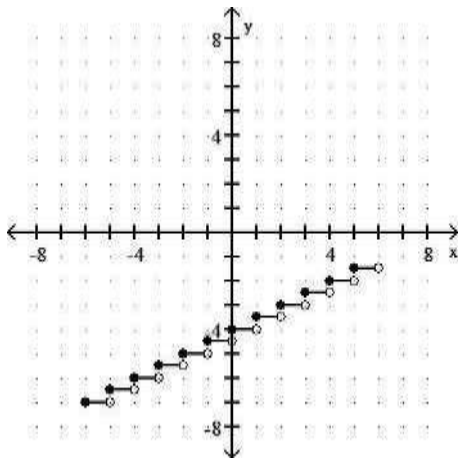

B)

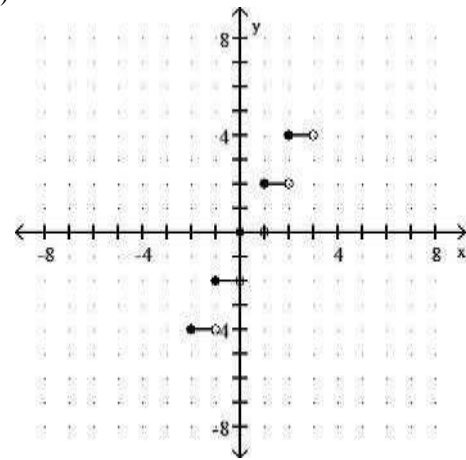

C)

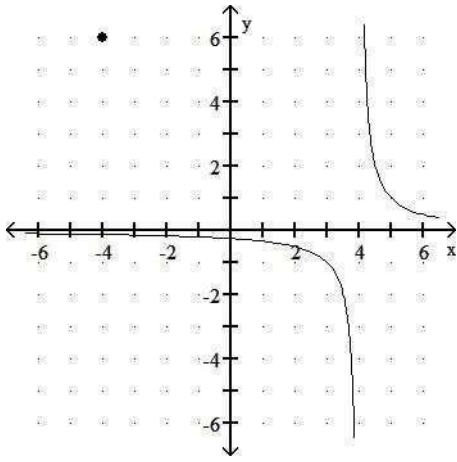

D)

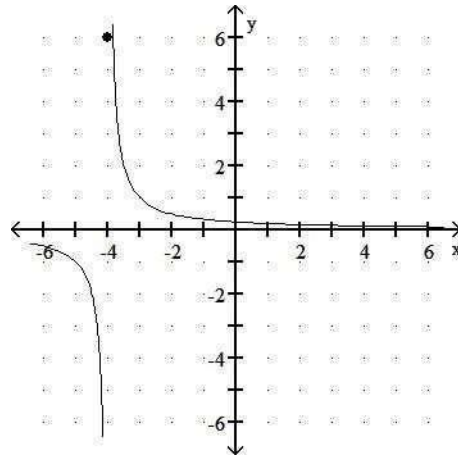

Write an equation for the piecewise function.

62)

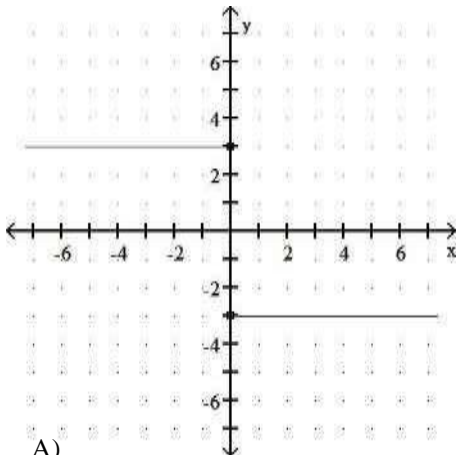

62) _____

A)

$$f(x) = \begin{cases} -3, & \text{for } x \leq 0, \\ 3, & \text{for } x > 0 \end{cases}$$

C)

$$f(x) = \begin{cases} 3x, & \text{for } x \leq 0, \\ -3x, & \text{for } x > 0 \end{cases}$$

B)

$$f(x) = \begin{cases} 3, & \text{for } x < 0, \\ -3, & \text{for } x \geq 0 \end{cases}$$

D)

$$f(x) = \begin{cases} 3, & \text{for } x \leq 0, \\ -3, & \text{for } x > 0 \end{cases}$$

63)

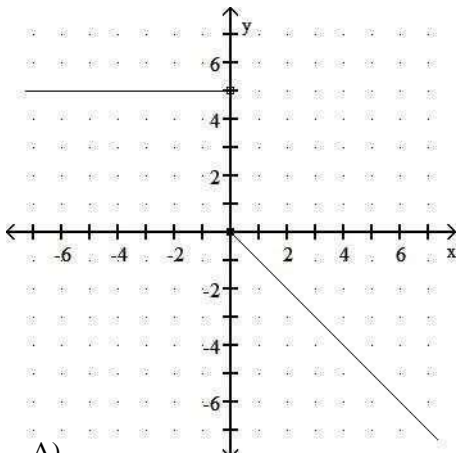

63) _____

A)

$$f(x) = \begin{cases} 5, & \text{for } x < 0, \\ -x, & \text{for } x \geq 0 \end{cases}$$

C)

$$f(x) = \begin{cases} 5, & \text{for } x < 0, \\ -x, & \text{for } x \geq 0 \end{cases}$$

B)

$$f(x) = \begin{cases} 5, & \text{for } x \leq 0, \\ -x, & \text{for } x > 0 \end{cases}$$

D)

$$f(x) = \begin{cases} 5, & \text{for } x < 0, \\ x, & \text{for } x \geq 0 \end{cases}$$

64)

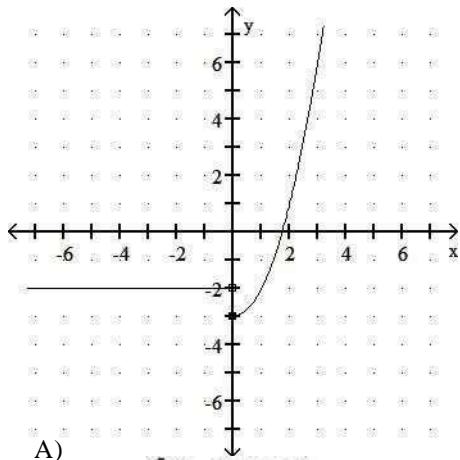

A)

$$f(x) = \begin{cases} 2, & \text{for } x < 0, \\ x^2 - 3, & \text{for } x \geq 0 \end{cases}$$

C)

$$f(x) = \begin{cases} -2, & \text{for } x < 0, \\ x^2 - 3, & \text{for } x \geq 0 \end{cases}$$

$$B) \quad f(x) = \begin{cases} 2, & \text{for } x \leq 0, \\ x^2 - 3, & \text{for } x > 0 \end{cases}$$

D)

$$f(x) = \begin{cases} 2, & \text{for } x < 0, \\ |x| - 3, & \text{for } x \geq 0 \end{cases}$$

64) _____

65)

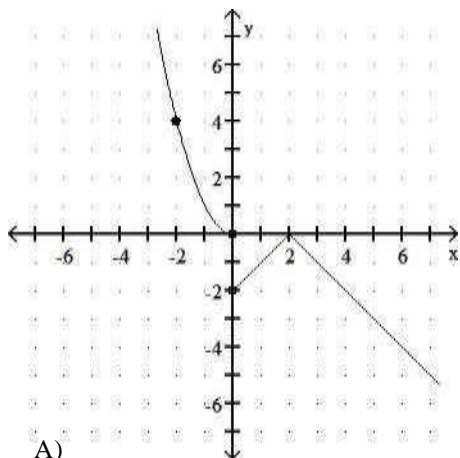

A)

$$f(x) = \begin{cases} x^2, & \text{for } x \leq 0, \\ |x - 2|, & \text{for } x > 0 \end{cases}$$

C)

$$f(x) = \begin{cases} -x^2, & \text{for } x \leq 0, \\ |x - 2|, & \text{for } x > 0 \end{cases}$$

$$B) \quad f(x) = \begin{cases} -|x - 2|, & \text{for } x < 0, \\ x^2, & \text{for } x \geq 0 \end{cases}$$

D)

$$f(x) = \begin{cases} x^2, & \text{for } x \leq 0, \\ -|x + 2|, & \text{for } x > 0 \end{cases}$$

65) _____

66)

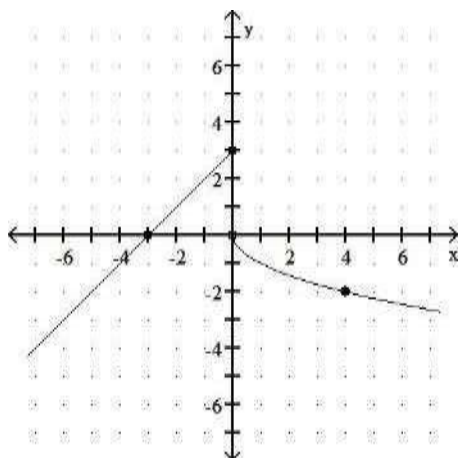

66) _____

A) $f(x) = \begin{cases} x + 3, & \text{for } x \leq 0, \\ \sqrt{x}, & \text{for } x > 0 \end{cases}$

C) $f(x) = \begin{cases} x + 3, & \text{for } x \leq 0, \\ -\sqrt{x}, & \text{for } x > 0 \end{cases}$

B) $f(x) = \begin{cases} -x + 3, & \text{for } x \leq 0, \\ -\sqrt{x}, & \text{for } x > 0 \end{cases}$

D) $f(x) = \begin{cases} x - 3, & \text{for } x \leq 0, \\ -x^2, & \text{for } x > 0 \end{cases}$

67)

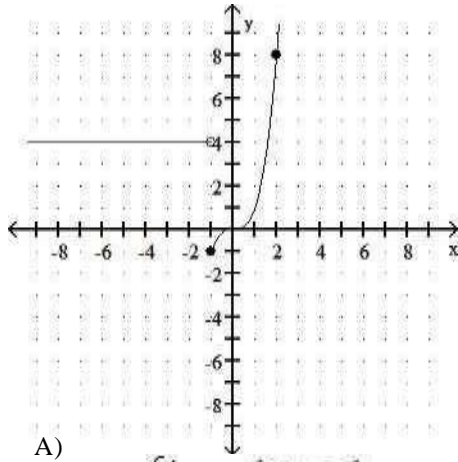

A) $f(x) = \begin{cases} 4, & \text{for } x < -1, \\ x^3, & \text{for } x \geq -1 \end{cases}$

C) $f(x) = \begin{cases} 4, & \text{for } x < -1, \\ -1, & \text{for } x \geq -1 \end{cases}$

B) $f(x) = \begin{cases} 4, & \text{for } x < -1, \\ x^3 - 1, & \text{for } x \geq -1 \end{cases}$

D) $f(x) = \begin{cases} 4, & \text{for } x < -1, \\ x^2, & \text{for } x \geq -1 \end{cases}$

67) _____

68)

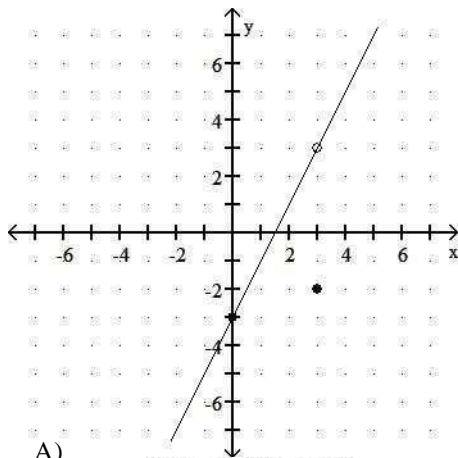

A) $f(x) = \begin{cases} 2x - 3, & \text{for } x < 3, \\ x - 3, & \text{for } x \neq 3, \\ -2, & \text{for } x = 3 \end{cases}$

C) $f(x) = \begin{cases} x - 3, & \text{for } x \neq 3, \\ -2, & \text{for } x = 3 \end{cases}$

B) $f(x) = \begin{cases} 2x - 3, & \text{for } x \neq 3, \\ -3, & \text{for } x = 3 \end{cases}$

D) $f(x) = \begin{cases} 2x - 3, & \text{for } x \neq 3, \\ -2, & \text{for } x = 3 \end{cases}$

68) _____

69)

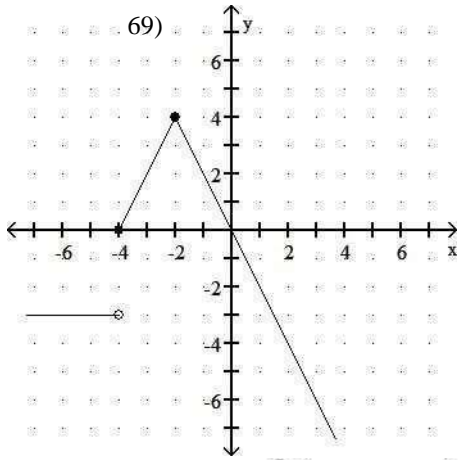

A) $f(x) = \begin{cases} -3, & \text{for } x < -4, \\ -2|x + 2| + 4, & \text{for } x \geq -4 \end{cases}$

C) $f(x) = \begin{cases} -3x, & \text{for } x < -4, \\ -2|x + 2| + 4, & \text{for } x \geq -4 \end{cases}$

B) $f(x) = \begin{cases} -3x, & \text{for } x \leq -4, \\ -2|x + 2| + 4, & \text{for } x > -4 \end{cases}$

D) $f(x) = \begin{cases} -3, & \text{for } x \leq -4, \\ -2|x + 2| + 4, & \text{for } x > -4 \end{cases}$

70)

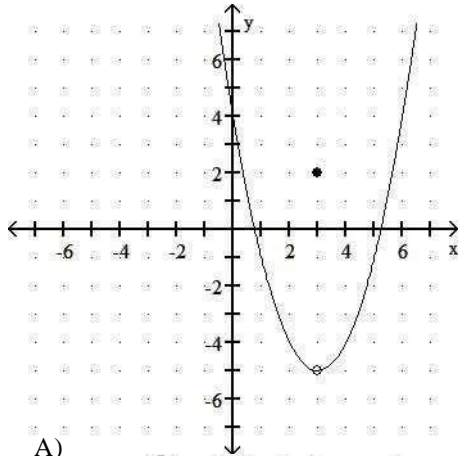

A) $f(x) = \begin{cases} (x + 3)^2 - 5, & \text{for } x \neq 3, \\ 2, & \text{for } x = 3 \end{cases}$

C) $f(x) = \begin{cases} |x - 3| - 5, & \text{for } x \neq 3, \\ 2, & \text{for } x = 3 \end{cases}$

B) $f(x) = \begin{cases} (x - 3)^2 - 5, & \text{for } x \neq 3, \\ 2, & \text{for } x = 3 \end{cases}$

D) $f(x) = (x - 3)^2 - 5$

71)

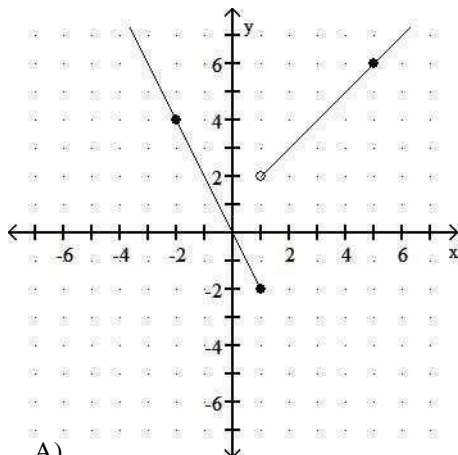

A) $f(x) = \begin{cases} -x, & \text{for } x \leq 1, \\ 2x + 1, & \text{for } x > 1 \end{cases}$

B) $f(x) = \begin{cases} -2x, & \text{for } x \leq 1, \\ x + 2, & \text{for } x > 1 \end{cases}$

—
—

70) _____

71) _____

$$C) f(x) = \begin{cases} 2x, & \text{for } x \leq 1, \\ x+1, & \text{for } x > 1 \end{cases}$$

$$D) f(x) = \begin{cases} -2x, & \text{for } x \leq 1, \\ x+1, & \text{for } x > 1 \end{cases}$$

For the pair of functions, find the indicated sum, difference, product, or quotient.

72) $f(x) = x - 1$, $g(x) = x - 5$ 72) _____
 Find $(f + g)(2)$.
 A) 0 B) -2 C) 10 D) 8

73) $f(x) = x^2 - 6$, $g(x) = 5x - 3$ 73) _____
 Find $(f + g)(5)$.
 A) 16 B) 21 C) 41 D) 141

74) $f(x) = 4x^2 + 7$, $g(x) = x + 1$ 74) _____
 Find $(f - g)(3)$.
 A) 41 B) -46 C) 45 D) 39

75) $f(x) = x - 5$, $g(x) = -2x^2 + 16x - 7$ 75) _____
 Find $(fg)(4)$.
 A) -25 B) -73 C) 225 D) -351

76) $f(x) = 5x - 7$, $g(x) = 3x^2 + 14x + 3$ 76) _____
 Find $(f/g)(-5)$.
 A) -4 B) $\frac{3}{8}$ C) $\frac{3}{8}$ D) $\frac{3}{8}$

77) $f(x) = \frac{5}{8}x^2 - \frac{1}{7}$, $g(x) = 7x + 1$ 77) _____
 Find $(f/g)(\frac{1}{6})$.
 A) $\frac{2}{3}$ B) does not exist C) $\frac{1}{2}$ D) 0

78) $f(x) = x^2 - 2$, $g(x) = 2x + 1$ 78) _____
 Find $(f/g)(\sqrt{11})$.
 A) $\frac{18\sqrt{11}-9}{43}$ B) $\frac{17\sqrt{11}+9}{21}$ C) $\frac{18-\sqrt{11}}{45}$ D) $\frac{\sqrt{11}-1}{2}$

79) $h(x) = x - 3$, $g(x) = \sqrt{x+1}$ 79) _____
 Find $(h + g)(15)$.
 A) 28 B) 16 C) 18 D) 19

80) $f(x) = x + 3$, $g(x) = \sqrt{x-7}$ 80) _____
 Find $(f - g)(-3)$.
 A) doesnot exist B) $\sqrt{10}$ C) 0 D) $\sqrt{7}$

81) $h(x) = x - 5$, $g(x) = \sqrt{x+8}$ 81) _____
 Find $(hg)(-6)$.
 A) -11 B) $\sqrt{2}$ C) does not exist D) $-\sqrt{2}$

82) $f(x) = 5x - 6$, $g(x) = 2x - 2$

Find $(f - g)(x)$.

A) $-3x + 4$

B) $7x - 8$

C) $3x - 4$

D) $3x - 8$

82) _____

83) $f(x) = 7x^2 - 8x$, $g(x) = x^2 - 6x - 16$

Find $(f/g)(x)$.

A) $\frac{7x}{x+1}$

B) $\frac{7-x}{16}$

C) $\frac{7x-8}{-6}$

D) $\frac{7x^2 - 8x}{x^2 - 6x - 16}$

83) _____

84) $f(x) = 7 - 6x$, $g(x) = -2x + 6$

Find $(f + g)(x)$.

A) $-4x + 13$

B) $-2x + 7$

C) $5x$

D) $-8x + 13$

84) _____

85) $f(x) = \sqrt{3x+2}$, $g(x) = \sqrt{16x-4}$

Find $(fg)(x)$.

A) $(3x + 2)(4x - 2)$

B) $(\sqrt{3x+2})(\sqrt{16x-4})$

C) $(3x + 2)(16x - 4)$

D) $(4x - 2)(\sqrt{3x+2})$

85) _____

86) $f(x) = 3x + 2$, $g(x) = 6x + 6$

Find $(fg)(x)$.

A) $18x^2 + 30x + 12$

B) $18x^2 + 18x + 12$

C) $x^2 + 12$

D) $9x^2 + 30x + 8$

86) _____

87) $f(x) = 5x - 2$, $g(x) = 3x - 5$

Find $(f/g)(x)$.

A) $\frac{5x-2}{3x-5}$

B) $\frac{3x+5}{5x+2}$

C) $\frac{5x+2}{3x+5}$

D) $\frac{3x-5}{5x-2}$

87) _____

88) $f(x) = 4 + x$, $g(x) = 8|x|$

Find $(\frac{f}{g})(x)$.

A) $\frac{8|x|}{4} + x$

B) $\frac{4+x}{8|x|}$

C) $8|x| - 4 + x$

D) $\frac{8|x|}{4+x}$

88) _____

89) $f(x) = 16 - x^2$; $g(x) = 4 - x$

Find $(f + g)(x)$.

A) $-x^2 + x + 12$

B) $x^3 - 4x^2 - 16x + 64$

C) $-x^2 - x + 20$

D) $4 + x$

89) _____

90) $f(x) = \frac{7}{9+x}$, $g(x) = \frac{1}{3+x}$

Find $(fg)(x)$.

A) $\frac{49}{(x-6)(3+x)}$

B) $\frac{2}{(x-7)(9+x)}$

C) $\frac{7}{(x-6)^2}$

D) $\frac{x-7}{2(9+x)}$

E) $\frac{49}{x-6^2}$

F) $\frac{2(9+x)}{x-7}$

D)

Find $(f/g)(x)$.

- A)
- B)
- C)
- D)

91) $\frac{49}{(x-6)^2}$

$f(x) = \frac{2}{x-7}$, $g(x) = \frac{1}{9+x}$

90)

91)

For the pair of functions, find the indicated domain.

92) $f(x) = 2x - 5$, $g(x) = \sqrt{x+3}$ 92) _____
 Find the domain of $f + g$.
 A) $[-3, \infty)$ B) $(-3, 3)$ C) $[3, \infty)$ D) $[0, \infty)$

93) $f(x) = 2x - 5$, $g(x) = \sqrt{x+5}$ 93) _____
 Find the domain of f/g .
 A) $[0, \infty)$ B) $(-5, 5)$ C) $(-5, \infty)$ D) $[5, \infty)$

94) $f(x) = x^2 - 9$, $g(x) = 2x + 3$ 94) _____
 Find the domain of $f - g$.
 A) $[3, \infty)$ B) $(-\infty, \infty)$ C) $(-3, 3)$ D) $[0, \infty)$

95) $f(x) = x^2 - 16$, $g(x) = 2x + 3$ 95) _____
 Find the domain of f/g .
 A) $(-\infty, \infty)$ B) $\left[-\infty, -\frac{3}{2}\right] \cup \left[-\frac{3}{2}, \infty\right)$
 C) $(-4, 4)$ D) $\left[-\frac{3}{2}, \infty\right)$

96) $f(x) = x^2 - 25$, $g(x) = 2x + 3$ 96) _____
 Find the domain of g/f .
 A) $\left[-\infty, -\frac{3}{2}\right] \cup \left[\frac{3}{2}, \infty\right)$ B) $(-\infty, -5) \cup (-5, 5) \cup (5, \infty)$
 C) $\left[-\frac{3}{2}, \infty\right)$ D) $(-\infty, \infty)$

97) $f(x) = \sqrt{x-1}$ and $g(x) = \frac{1}{x-3}$ 97) _____
 Find the domain of fg .
 A) $[0, 3) \cup (3, \infty)$ B) $[1, \infty)$ C) $(1, 3) \cup (3, \infty)$ D) $[1, 3) \cup (3, \infty)$

98) $f(x) = \sqrt{4-x}$, $g(x) = \sqrt{x-3}$ 98) _____
 Find the domain of fg .
 A) $(-\infty, 3) \cup (4, \infty)$ B) $[3, 4]$
 C) $(3, 4)$ D) $(-\infty, 12) \cup (12, \infty)$

99) $f(x) = 4x - 6$, $g(x) = \frac{3}{x+9}$ 99) _____
 Find the domain of $f + g$.
 A) $(-\infty, -9)$ or $(-9, \infty)$ B) $(-\infty, -3)$ or $(-3, \infty)$
 C) $(-\infty, \infty)$ D) $(0, \infty)$

100) $f(x) = \frac{3x}{x-5}$, $g(x) = \frac{4}{x+8}$ 100) _____
 Find the domain of $f + g$.
 A) $(-\infty, \infty)$ B) $(-\infty, -5) \cup (-5, 8) \cup (8, \infty)$
 C) $(-\infty, -8) \cup (-8, 5) \cup (5, \infty)$ D) $(-\infty, -4) \cup (-4, -3) \cup (-3, \infty)$

101) $f(x) = 3x^2 - 5$, $g(x) = 2x^3 + 3$

Find the domain of $f + g$.

- A) $(-\infty, \infty)$
- C) $(0, \infty)$

- B) $(-\infty, -3) \cup (-3, -2) \cup (-2, \infty)$
- D) $(-\infty, 0) \cup (0, \infty)$

101) _____

Consider the functions F and G as shown in the graph. Provide an appropriate response.

102) Find the domain of $F + G$.

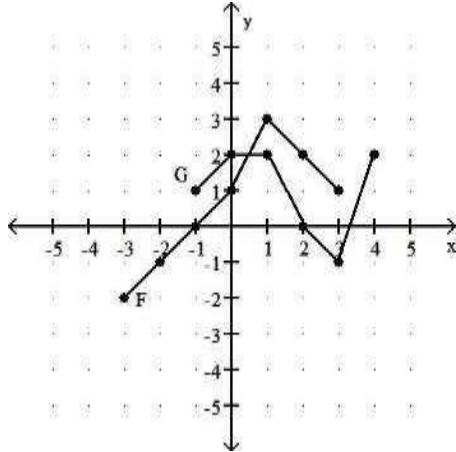

- A) $[-3, 3]$
- B) $[-3, 4]$
- C) $[-1, 4]$
- D) $[-1, 3]$

102) _____

103) Find the domain of $F - G$.

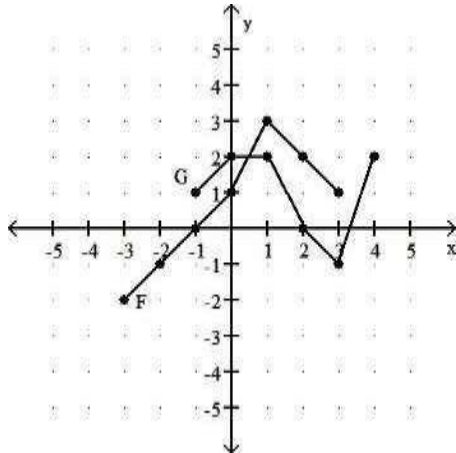

- A) $[-3, 4]$
- B) $[-1, 3]$
- C) $[-1, 4]$
- D) $[-3, 3]$

103) _____

104) Find the domain of FG .

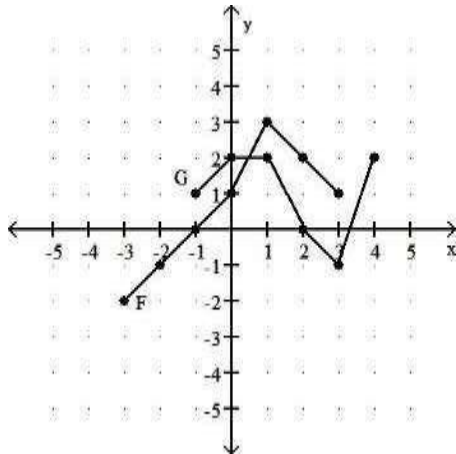

- A) $[-3, 3]$
- B) $[-1, 4]$
- C) $[-1, 3]$
- D) $[-3, 4]$

104) _____

105) Find the domain of F/G .

105) _____

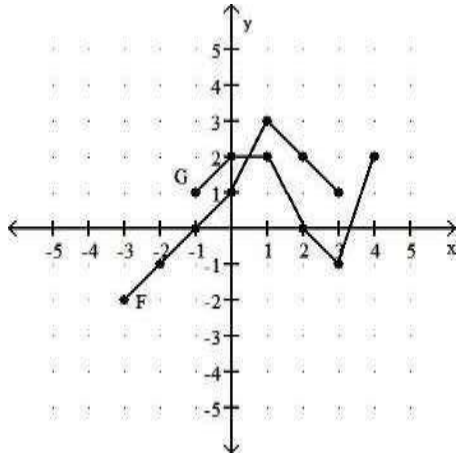

A) $[-3, -1) \cup (-1, 4)$

B) $[-1, 3]$

C) $[-1, 2) \cup (2, 3]$

D) $[-3, 4]$

106) Find the domain of G/F .

106) _____

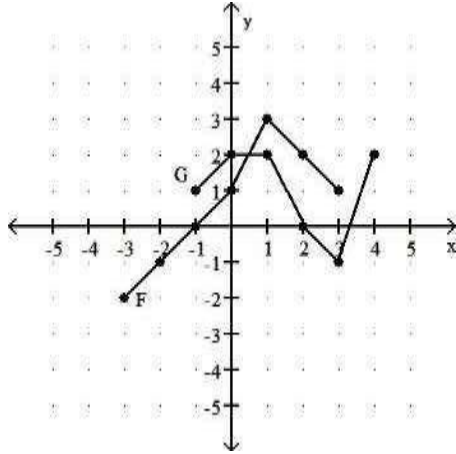

A) $(-1, 3]$

B) $[-3, 3]$

C) $[-3, 4]$

D) $[-1, 2) \cup (2, 3]$

107) Graph $F + G$.

107) _____

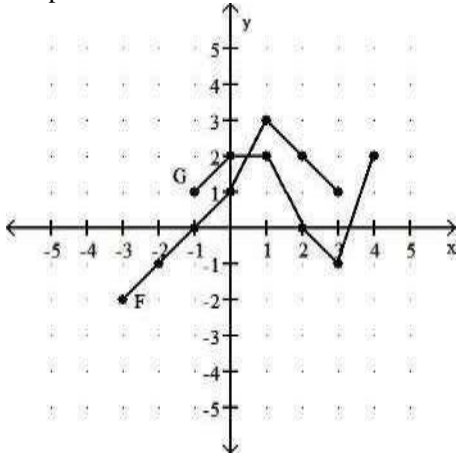

A)

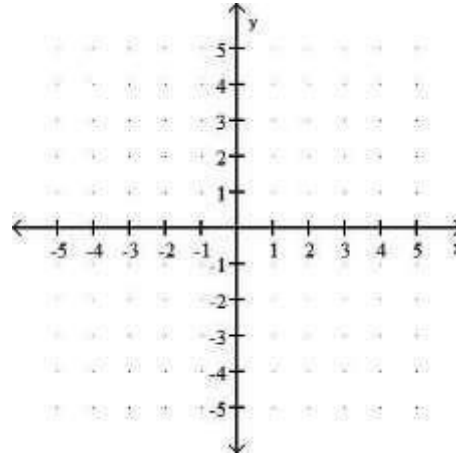

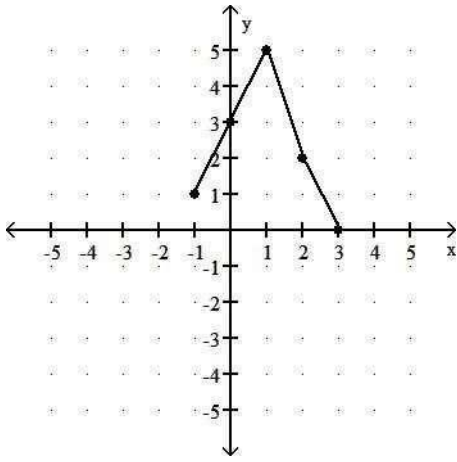

B)

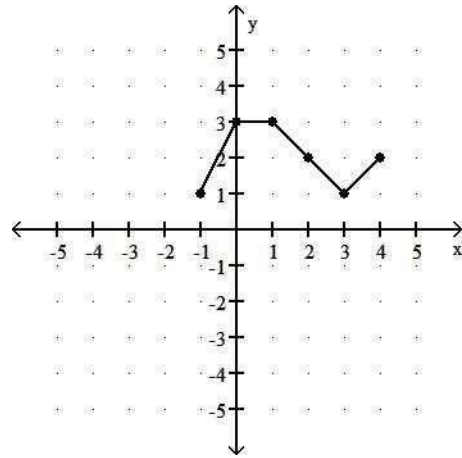

C)

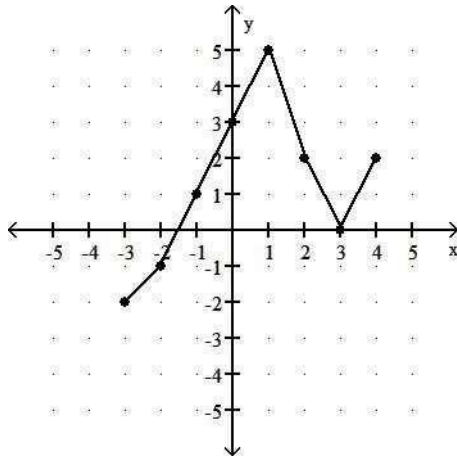

D)

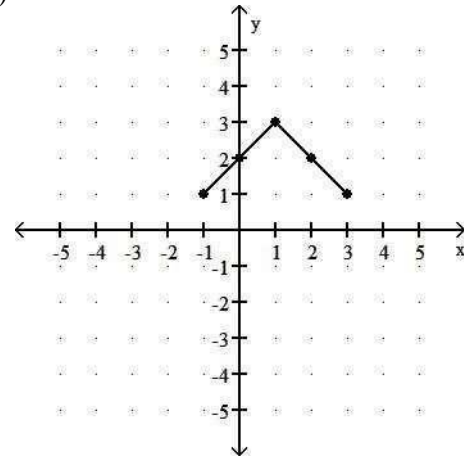

108) Graph F - G.

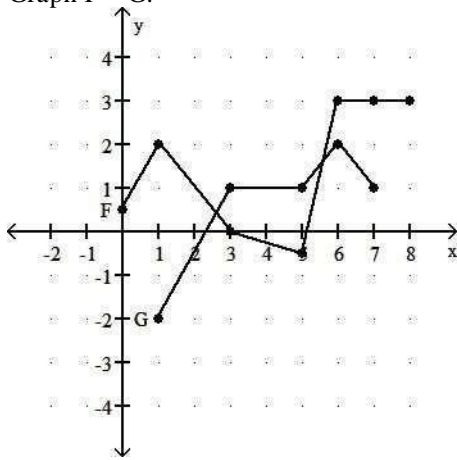

A)

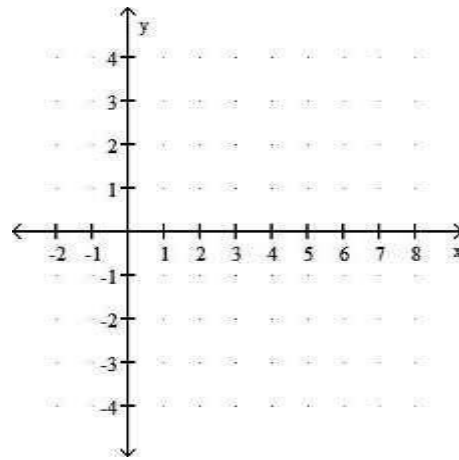

108) _____

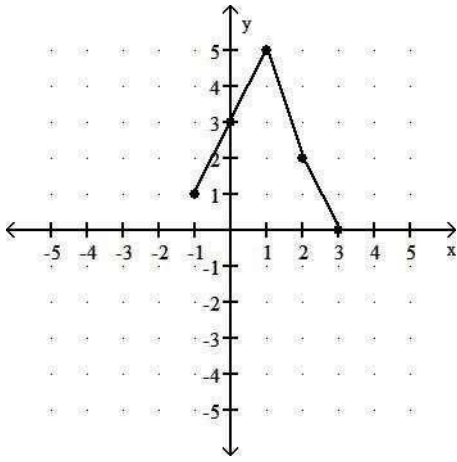

B)

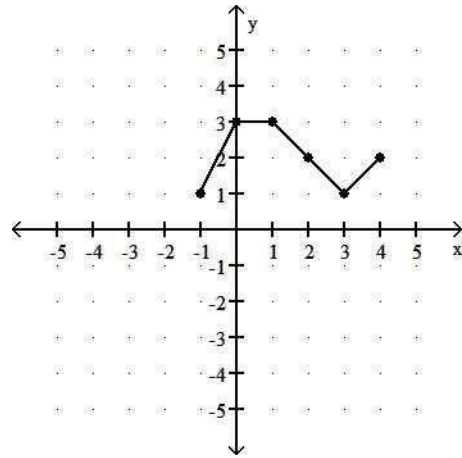

C)

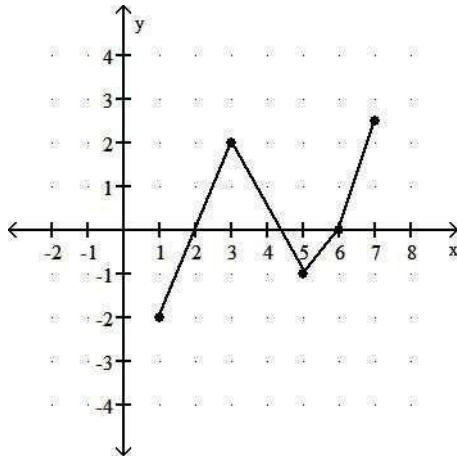

D)

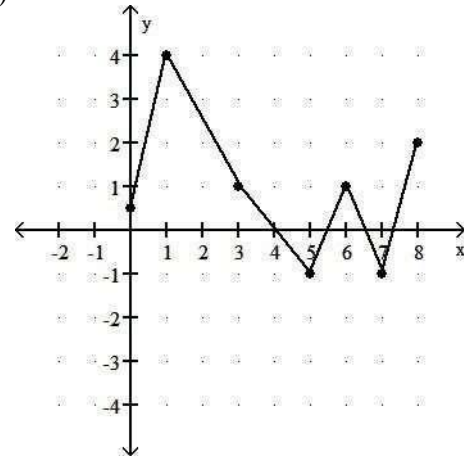

109) Graph G - F.

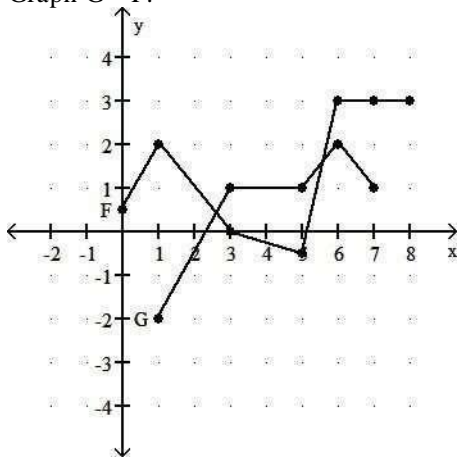

A)

109) _____

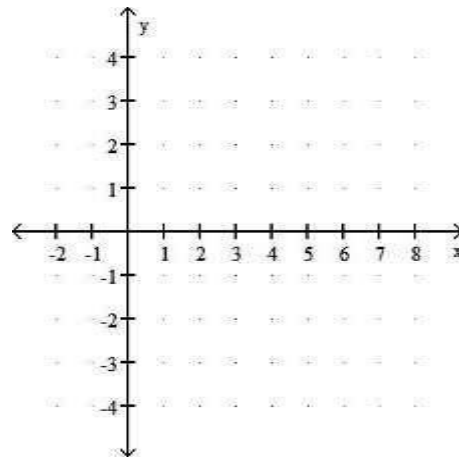

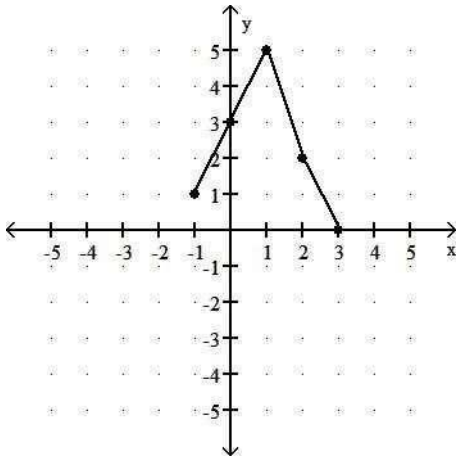

B)

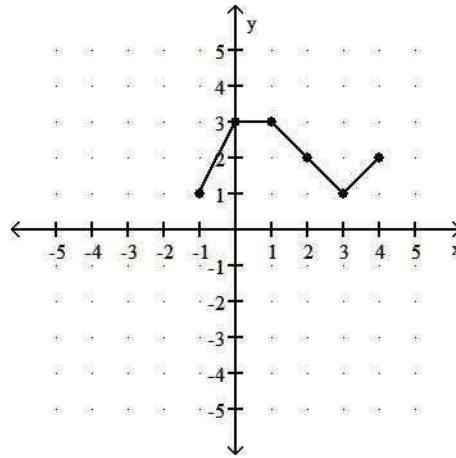

C)

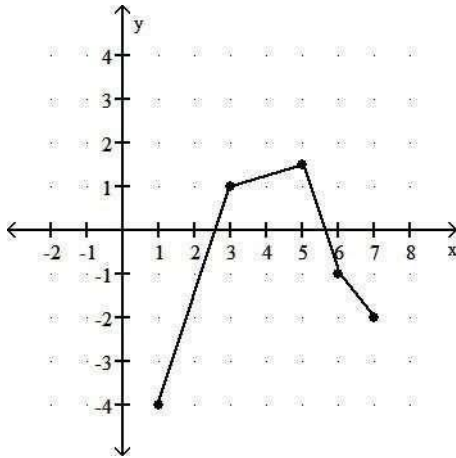

D)

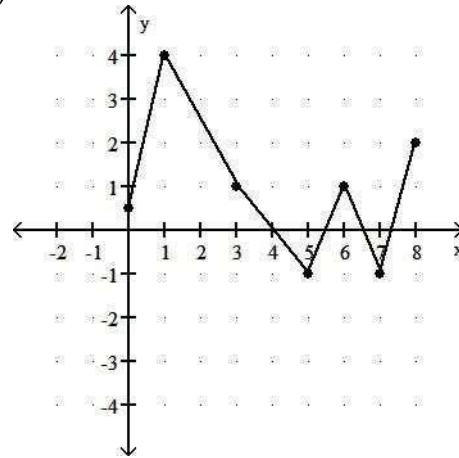

Solve.

110) At Allied Electronics, production has begun on the X-15 Computer Chip. The total revenue function is given by $R(x) = 59x - 0.3x^2$ and the total cost function is given by $C(x) = 7x + 13$, where x represents the number of boxes of computer chips produced. The total profit function, $P(x)$, is such that $P(x) = R(x) - C(x)$. Find $P(x)$.

110) _____

A) $P(x) = -0.3x^2 + 45x + 13$

B) $P(x) = -0.3x^2 + 52x - 13$

C) $P(x) = 0.3x^2 + 52x - 26$

D) $P(x) = 0.3x^2 + 45x - 39$

111) At Allied Electronics, production has begun on the X-15 Computer Chip. The total revenue function is given by $R(x) = 53x - 0.3x^2$ and the total profit function is given by $P(x) = -0.3x^2 + 51x - 13$, where x represents the number of boxes of computer chips produced.

111) _____

The total cost function, $C(x)$, is such that $C(x) = R(x) - P(x)$. Find $C(x)$.

A) $C(x) = 4x + 9$

B) $C(x) = 2x + 13$

C) $C(x) = 3x + 18$

D) $C(x) = -0.3x^2 + 4x + 13$

112) At Allied Electronics, production has begun on the X-15 Computer Chip. The total cost function is given by $C(x) = 11x + 14$ and the total profit function is given by $P(x) = -0.3x^2 + 38x - 14$, where x represents the number of boxes of computer chips produced. The total revenue function,

112) _____

$R(x)$, is such that $R(x) = C(x) + P(x)$. Find $R(x)$.

A) $R(x) = 49x - 0.3x^2$

B) $R(x) = 49x + 0.3x^2$

C)

R(

$$x) = 48x - 0.6x^2$$

$$\begin{aligned} \text{D) } R(x) &= \\ &= \\ &51 \\ &x - \\ &0. \\ &3 \\ &x^2 \end{aligned}$$

113) AAA Technology finds that the total revenue function associated with producing a new type of computer chip is $R(x) = 79 - 0.3x^2$, and the total cost function is $C(x) = 3x + 17$, where x represents the number of units of chips produced. Find the total profit function, $P(x)$.

A) $P(x) = -0.03x^2 - 3x + 62$

B) $P(x) = -0.03x^2 + 3x + 96$

C) $P(x) = 0.03x^2 + 3x + 64$

D) $P(x) = -0.03x^2 + 3x - 62$

114) Acme Communication finds that the total revenue function associated with producing a new type of cellular phone is $R(x) = 206x - x^2$, and the total cost function is $C(x) = 5000 + 9x$, where x represents the number of units of cellular phones produced. Find the total profit function, $P(x)$.

A) $P(x) = -2x^2 + 221x - 6000$

B) $P(x) = x^4 - 197x^2 + 5000$

C) $P(x) = -x^2 + 197x - 5000$

D) $P(x) = -x^2 + 215x + 5000$

For the function f , construct and simplify the difference quotient

$$\frac{f(x+h) - f(x)}{h}$$

115) $f(x) = 8x + \frac{1}{2}$

A) $\frac{2}{h}$

B) 8

C) $\frac{16(x+1)}{h}$

D) 0

115) _____

116) $f(x) = \frac{1}{5x}$

A) $\frac{-1}{x(x+h)}$

B) $\frac{-1}{5x(x+h)}$

C) 0

D)

116) _____

117) $f(x) = \frac{1}{5x}$

A) $\frac{18}{(x+h+13)(x+13)}$

B) $\frac{234}{(x+h+13)(x+13)}$

C) $\frac{18}{(x+h+13)(x+13)}$

D) $\frac{18}{(x+18)^2}$

117) _____

118) $f(x) = \frac{x}{5-x}$

A) $\frac{x}{(5-x+h)(5-x)}$

B) $\frac{5}{(5-x-h)(5-x)}$

C) $\frac{hx}{(5-x-h)(5+x)}$

D) $\frac{5}{(5-x+h)(5-x)}$

118) _____

$$\frac{x-10}{x-10}$$

119)

A) $\frac{13}{x(x+3)}$

B) $\frac{13(x+h+3)}{(x+3)}$

C) $\frac{14}{(x+3)(x-3)}$

D) $\frac{13}{(x+h+3)(x+3)}$

120) $f(x) = 7 - 6x^3$

A) $-21x^2$

B) $-6(x^2 - xh - h^2)$

C) $-6(3x^2 - 3x - h)$

D) $-6(3x^2 + 3xh + h^2)$

121) $f(x) = 7x^2 + 5x$

A) $14x + 7h + 5$

B) $14x + 5$

C) $x^2 + 7h + 5x$

D) $21x - 9h + 10$

122) $f(x) = 5|x| + 3x$

A) $-2h$

B) $\frac{5|x+h| - 3h - 5|x|}{h}$

C) $-4h$

D) $\frac{-5|x+h| - 4h + 5|x|}{h}$

Find the requested function value.

123)

$$f(x) = \frac{x-6}{x}, g(x) = 7x+3$$

Find $(g \circ f)(20)$.

A) 17

B) $\frac{137}{7}$

C) 20

D) 286

124) $f(x) = 9x + 7, g(x) = -2x^2 - 3x + 9$

Find $(f \circ g)(-9)$.

A) -1127

B) 379

C) 493

D) -10,721

125) $f(x) = 5x + 6, g(x) = -6x^2 - 4x - 8$

Find $(g \circ f)(8)$.

A) -2114

B) -12,888

C) -434

D) -468

126)

$$f(x) = \frac{x-3}{6}, g(x) = 8x+1$$

Find $(g \circ f)(-27)$.

A) -39

B) 1075

C) $\frac{109}{-}$

D) -45

For the pair of functions, find the indicated composition.

127) $f(x) = 6x + 14, g(x) = 5x - 1$

Find $(f \circ g)(x)$.

A) $30x + 69$

B) $30x + 20$

C) $30x + 13$

D) $30x + 8$

128) $f(x) = -2x + 3, g(x) = 6x + 4$

Find $(g \circ f)(x)$.

A) $-12x - 14$

B) $-12x + 22$

C) $12x + 22$

D) $-12x + 11$

129) $f(x) = \frac{5}{x-7}$, $g(x) = \frac{3}{2x}$ 129) _____
 Find $(f \circ g)(x)$.
 A) $\frac{5x}{3-14x}$ B) $\frac{3x-21}{10x}$ C) $\frac{10x}{3+14x}$ D) $\frac{10x}{3-14x}$

130) $f(x) = \frac{x-10}{3}$, $g(x) = 3x+10$ 130) _____
 Find $(g \circ f)(x)$.
 A) $x+20$ B) $\frac{10}{x-}$ C) x D) $3x+20$

131) $f(x) = \sqrt{x+2}$, $g(x) = 8x-6$ 131) _____
 Find $(f \circ g)(x)$.
 A) $\sqrt{x-4}$ B) $\sqrt{x+2} - 6$ C) $\sqrt{2x-1}$ D) $2\sqrt{2x+1}$

132) $f(x) = 4x^2 + 2x + 4$, $g(x) = 2x - 5$ 132) _____
 Find $(g \circ f)(x)$.
 A) $8x^2 + 4x + 13$ B) $4x^2 + 4x + 3$ C) $8x^2 + 4x + 3$ D) $4x^2 + 2x - 1$

133) $f(x) = \frac{9}{x}$, $g(x) = 8x^4$ 133) _____
 Find $(g \circ f)(x)$.
 A) $\frac{9}{8x^4}$ B) $\frac{52,488}{x^4}$ C) $\frac{8x^4}{9}$ D) $\frac{8x^4}{6561}$

134) $f(x) = \frac{9}{8}x$, $g(x) = -\frac{8}{9}x$ 134) _____
 Find $(f \circ g)(x)$.
 A) x B) 0 C) $-x$ D) 1

135) $f(x) = -4 + 3$, $g(x) = \sqrt{x-3}$ 135) _____
 Find $(g \circ f)(x)$.
 A) x^4 B) $-x$ C) x
 D) $|x|$

136) $f(x) = x^3 + 6x^2 + 7x + 5$, $g(x) = x - 1$ 136) _____
 Find $(f \circ g)(x)$.
 A) $x^3 + 3x^2 - 2x + 3$ B) $+6 + 7x + 6$
 $x^3 + 9 + 22x + 19$ D) $+6 + 7x + 4$
 C) $x^3 + x^2$ $x^3 + x^2$

For the pair of functions, find the indicated domain.

137) $f(x) = 4x + 12$, $g(x) = x + 2$ 137) _____
 Find the domain of $f \circ g$.
 A) $(-\infty, -5] \cup [-5, \infty)$ B) $(-\infty, -5) \cup (-5, \infty)$
 C) $(-\infty, \infty)$ D) $(-\infty, 5) \cup (5, \infty)$

138)

$f(x) =$

$\frac{2}{x+9}$ 138)

$g(x) = x + 6$

Find the domain of $f \circ g$.

- A) $(-\infty, -15] \cup [-15, \infty)$
 C) $(-\infty, \infty)$

- B) $(-\infty, -9) \cup (-9, \infty)$
 D) $(-\infty, -15) \cup (-15, \infty)$

139) $f(x) = \frac{7}{x+9}, g(x) = x + 6$

Find the domain of $g \circ f$.

- A) $(-\infty, -15) \cup (-15, \infty)$
 C) $(-\infty, \infty)$

- B) $(-\infty, -9) \cup (-9, \infty)$
 D) $(-\infty, -9] \cup [-9, \infty)$

140) $f(x) = 2x - 5, g(x) = \sqrt{x+10}$

Find the domain of $f \circ g$.

- A) $[0, \infty)$ B) $[-10, \infty)$

- C) $[10, \infty)$ D) $(-10, 10)$

141) $f(x) = 2x - 5, g(x) = \sqrt{x+2}$

Find the domain of $g \circ f$.

- A) $(-2, 2)$ B) $[-\infty, 1.5)$

- C) $[2, \infty)$ D) $[1.5, \infty)$

142) $f(x) = x^2 - 49, g(x) = 2x + 3$

Find the domain of $f \circ g$.

- A) $(-\infty, \infty)$ B) $(-7, 7)$

- C) $[7, \infty)$ D) $[0, \infty)$

143) $f(x) = x^2 - 36, g(x) = 2x + 3$

Find the domain of $g \circ f$.

- A) $\left[-\frac{3}{2}, \infty\right)$ B) $(-6, 6)$
 C) $\left(-\infty, -\frac{3}{2}\right] \cup \left[-\frac{3}{2}, \infty\right)$ D) $(-\infty, \infty)$

144) $f(x) = \sqrt{x}, g(x) = 3x + 18$

Find the domain of $f \circ g$.

- A) $[-6, \infty)$ B) $(-\infty, -6] \cup [0, \infty)$ C) $(-\infty, \infty)$ D) $[0, \infty)$

145) $f(x) = x^2 - 81, g(x) = 2x + 3$

Find the domain of $g \circ f$.

- A) $[9, \infty)$ B) $\left(-\infty, -\frac{3}{2}\right] \cup \left[-\frac{3}{2}, \infty\right)$
 C) $(-\infty, \infty)$ D) $(-9, 9)$

Find $f(x)$ and $g(x)$ such that $h(x) = (f \circ g)(x)$.

146) $h(x) = \frac{1}{x^2 - 9}$

- A) $f(x) = \frac{1}{x^2 - 9}$

$g(x) = x$

139) _____

140) _____

141) _____

142) _____

143) _____

144) _____

145) _____

146) _____

$$f(x) = \frac{1}{x^2 - 9}, g(x) =$$

B) $f(x) = \frac{1}{x^2}$

C) $f(x) = \frac{1}{x^2 - 9}, g(x) = x^2 - 9$

,
g(x) =
=
x - 9
D) $f(x) = \frac{1}{x^2}, g(x) = -\frac{1}{9}$

147) $h(x) = |8x + 8|$

A) $f(x) = |-x|, g(x) = 8x - 8$
C) $f(x) = x, g(x) = 8x + 8$

B) $f(x) = |x|, g(x) = 8x + 8$
D) $f(x) = -|x|, g(x) = 8x + 8$

147) _____

148) $h(x) = \frac{2}{x^2} + 2$

A) $f(x) = x + 2, g(x) = \frac{2}{x^2}$
C) $f(x) = x, g(x) = \frac{2}{x^2} + 2$

B) $f(x) = \frac{2}{x^2}, g(x) = 2$
D) $f(x) = \frac{1}{x^2}, g(x) = \frac{2}{x^2} + 2$

148) _____

149) $h(x) = \frac{8}{\sqrt{6x+8}}$

A) $f(x) = 8, g(x) = \sqrt{6x+8}$
 $f(x) = \sqrt{6x+8}, g(x) = 8$

B) $f(x) = \frac{8}{x}, g(x) = 6x + 8$
D) $f(x) = \frac{8}{\sqrt{x}}, g(x) = 6x + 8$

149) _____

150) $h(x) = (-5x - 1)5$

A) $f(x) = -5x - 1, g(x) = x5$
C) $f(x) = x5, g(x) = -5x - 1$

B) $f(x) = (-5x)5, g(x) = -1$
D) $f(x) = -5x5, g(x) = x - 1$

150) _____

151) $h(x) = \sqrt{37x^2 + 79}$

A) $f(x) = \sqrt{37x^2}, g(x) = \sqrt{79}$
C) $f(x) = 37x^2 + 79, g(x) = \sqrt{x}$

B) $f(x) = \sqrt{37x+79}, g(x) = x^2$
D) $f(x) = \sqrt{x}, g(x) = 37x^2 + 79$

151) _____

152) $h(x) = \sqrt{8 - \sqrt{x-8}}$

A) $f(x) = \sqrt{8-x}, g(x) = \sqrt{x-8}$
C) $f(x) = \sqrt{x-8}, g(x) = \sqrt{8-x}$

B) $f(x) = \sqrt{x-8}, g(x) = \sqrt{x-8}$
D) $f(x) = \sqrt{8+x}, g(x) = \sqrt{x-8}$

152) _____

153) $h(x) = (x-1)^5 + 8(x-1)^4 - (x-1)^2 + 9$

A) $f(x) = x^5 - 8x^4 + 9x^2 + 9, g(x) = x + 1$

B) $f(x) = x^5 + x^4 - x^2 + 9, g(x) = x - 1$

153) _____

C) $f(x) = x^5 + 8x^4 - 9x^2$, $g(x) = x - 10$

D) $f(x) = x^5 + 8x^4 - 9x^2 + 9$, $g(x) = x - 1$

- 154) $h(x) = \frac{(x^3 + 3)^8}{3 - x^3}$ 154) _____
- A) $f(x) = (x^3 + 3)^8, g(x) = 3 - x^3$
- B) $f(x) = \frac{x^3 + 3}{3 - x^3}, g(x) = \frac{x^3 + 3}{3 - x^3}$
- C) $f(x) = \frac{1}{x^8}, g(x) = \frac{x^3 + 3}{3 - x^3}$
- D) $f(x) = x^8, g(x) = \frac{x^3 + 3}{3 - x^3}$

- 155) $h(x) = \sqrt{\frac{x-3}{x-1}}$ 155) _____
- A) $f(x) = \frac{\sqrt{x-3}}{x-3}, g(x) = \frac{1}{x-1}$
- B) $f(x) = \sqrt{x}, g(x) = \frac{x-3}{x-1}$
- C) $f(x) = \frac{1}{x-1}, g(x) = \sqrt{x}$
- D) $f(x) = \sqrt{\frac{1}{x-1}}, g(x) = x-3$

Solve the problem.

- 156) A balloon (in the shape of a sphere) is being inflated. The radius is increasing at a rate of 13 cm per second. Find a function, $r(t)$, for the radius in terms of t . Find a function, $V(r)$, for the volume of the balloon in terms of r . Find $(V \circ r)(t)$. 156) _____
- A) $(V \circ r)(t) = \frac{114244\pi\sqrt{t}}{3}$
- B) $(V \circ r)(t) = \frac{8788\pi t^3}{3}$
- C) $(V \circ r)(t) = \frac{1183\pi t^3}{3}$
- D) $(V \circ r)(t) = \frac{10985\pi t^2}{3}$
- 157) A stone is thrown into a pond. A circular ripple is spreading over the pond in such a way that the radius is increasing at the rate of 5.3 feet per second. Find a function, $r(t)$, for the radius in terms of t . Find a function, $A(r)$, for the area of the ripple in terms of r . Find $(A \circ r)(t)$. 157) _____
- A) $(A \circ r)(t) = 10.6\pi t^2$
- B) $(A \circ r)(t) = 5.3\pi t^2$
- C) $(A \circ r)(t) = 28.09\pi t^2$
- D) $(A \circ r)(t) = 28.09\pi^2 t$
- 158) Ken is 6 feet tall and is walking away from a streetlight. The streetlight has its light bulb 14 feet above the ground, and Ken is walking at the rate of 2.5 feet per second. Find a function, $d(t)$, which gives the distance Ken is from the streetlight in terms of time. Find a function, $S(d)$, which gives the length of Ken's shadow in terms of d . Then find $(S \circ d)(t)$. 158) _____
- A) $(S \circ d)(t) = 1.88t$
- B) $(S \circ d)(t) = 2.38t$
- C) $(S \circ d)(t) = 4.23t$
- D) $(S \circ d)(t) = 1.38t$

- 1) D
- 2) C
- 3) C
- 4) B
- 5) C
- 6) A
- 7) A
- 8) C
- 9) D
- 10) C
- 11) B
- 12) A
- 13) D
- 14) B
- 15) B
- 16) C
- 17) C
- 18) A
- 19) C
- 20) D
- 21) A
- 22) B
- 23) A
- 24) D
- 25) B
- 26) A
- 27) D
- 28) C
- 29) B
- 30) B
- 31) B
- 32) D
- 33) D
- 34) C
- 35) C
- 36) A
- 37) B
- 38) B
- 39) D
- 40) A
- 41) C
- 42) A
- 43) A
- 44) B
- 45) B
- 46) D
- 47) C
- 48) D
- 49) B
- 50) D
- 51) A

52) D
53) B
54) B
55) C
56) A
57) D
58) C
59) D
60) B
61) A
62) D
63) C
64) C
65) A
66) C
67) C
68) D
69) A
70) B
71) D
72) B
73) C
74) D
75) A
76) A
77) B
78) A
79) B
80) A
81) B
82) C
83) D
84) D
85) B
86) A
87) A
88) D
89) C
90) D
91) D
92) A
93) C
94) B
95) B
96) B
97) D
98) B
99) A
100) C
101) A
102) D
103) B

104) C
105) C
106) A
107) A
108) A
109) C
110) B
111) B
112) A
113) A
114) C
115) B
116) B
117) A
118) B
119) D
120) D
121) A
122) B
123) A
124) A
125) B
126) A
127) D
128) B
129) D
130) C
131) C
132) C
133) B
134) C
135) C
136) A
137) C
138) D
139) B
140) B
141) D
142) A
143) D
144) A
145) C
146) C
147) B
148) A
149) D
150) C
151) D
152) A
153) D
154) D
155) B

156) B

157) C

158) A