

Test Bank for Algebra and Trigonometry with Modeling and Visualization 6th Edition Rockswold 0134418026 9780134418025

Full link download

Test Bank:

<https://testbankpack.com/p/test-bank-for-algebra-and-trigonometry-with-modeling-and-visualization-6th-edition-rockswold-0134418026-9780134418025/>

MULTIPLE CHOICE. Choose the one alternative that best completes the statement or answers the question.

Find a point-slope form for the equation of the line satisfying the conditions.

- 1) Slope -2, passing through (7, 2)

A) $y = -2(x - 7) - 2$

B) $y = -2(x - 7) + 2$

C) $y - 2 = 2x - 7$

D) $y - 2 = -2x + 7$

Answer: B

- 2) Slope -8, passing through (-5, -3)

A) $y + 3 = 8x + 5$

B) $y = 8(x - 5) + 3$

C) $y = -8(x + 5) - 3$

D) $y = -8(x - 5) + 3$

Answer: C

- 3) Passing through (-8, -2) and (-5, 2)

A) $y - \frac{8}{3} = \frac{8}{3}(x + 8) - 2$

B) $y = -\frac{8}{3}(x - 8) + 2$

C) $y = 2(x + \frac{8}{3}) + 8$

D) $y = -2(x - \frac{8}{3}) - 8$

Answer: A

Write an equation in slope-intercept form for the line shown.

4)

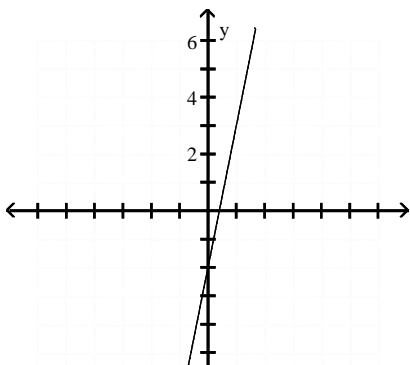

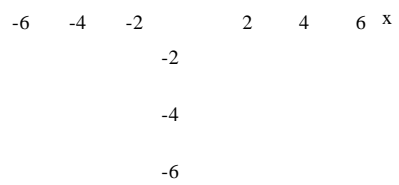

- A) $y = 5x - 2$
- B) $y = -5x + 2$
- C) $y = -5x - 2$
- D) $y = 5x + 2$

Answer: A

5)

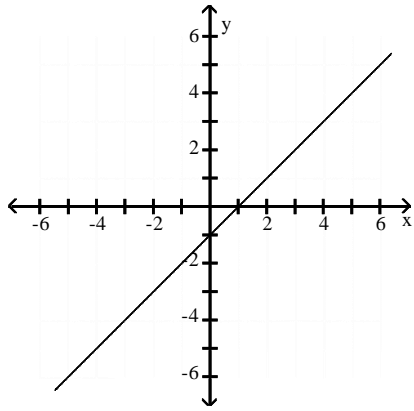

- A) $y = -x - 1$
- B) $y = x + 1$
- C) $y = -x + 1$
- D) $y = x - 1$

Answer: D

6)

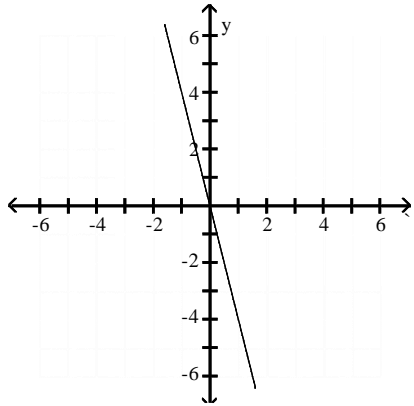

- A) $y = \frac{x}{4}$
- B) $y = \frac{x}{-4}$
- C) $y = 4x$
- D) $y = -4x$

Answer: D

7)

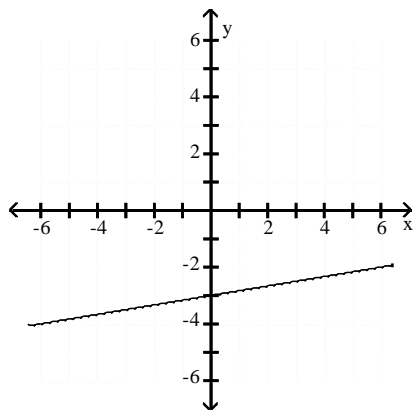

A) $y = 6x + 3$

B) $y = \frac{1}{6}x - 3$

C) $y = 6x - 3$

D) $y = \frac{1}{6}x + 3$

Answer: B

8)

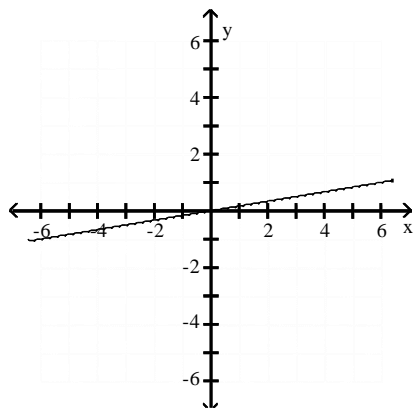

A) $y = \frac{1}{6}x$

B) $y = -\frac{1}{6}x$

C) $y = -6x$

D) $y = 6x$

Answer: A

9)

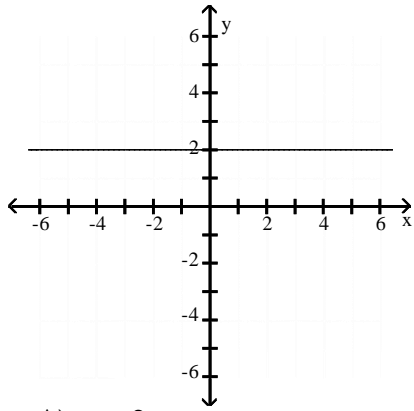

- A) $x = -2$
- B) $y = -2$
- C) $y = 2$
- D) $x = 2$

Answer: C

Match the equation to its graph.

10) $y = 4x + 6$

A)

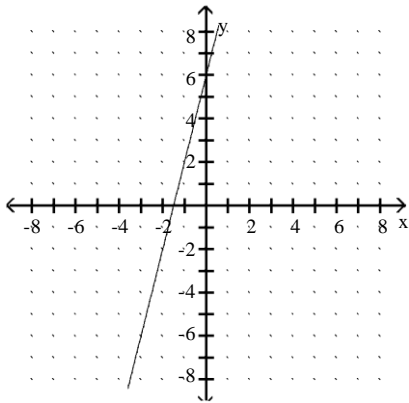

B)

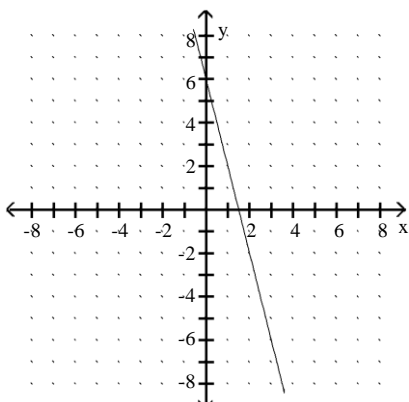

C)

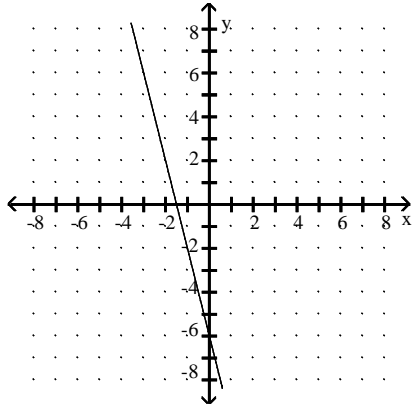

D)

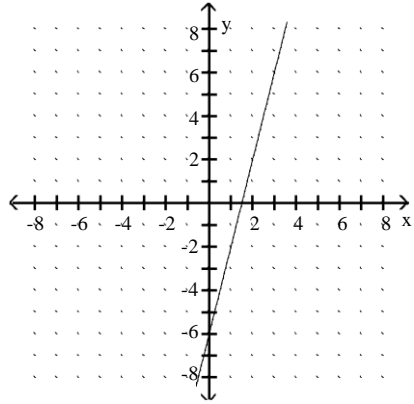

Answer: A

11) $y = 2x - 5$

A)

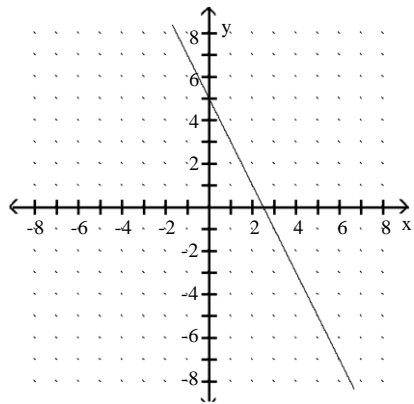

B)

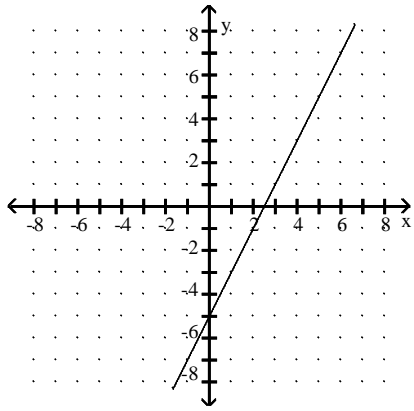

C)

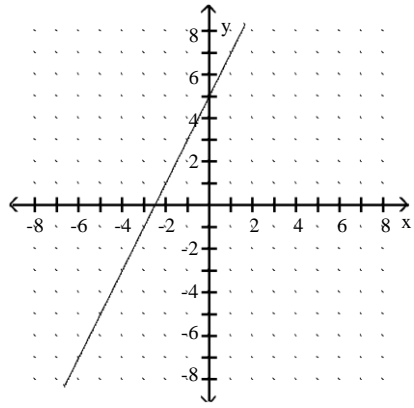

D)

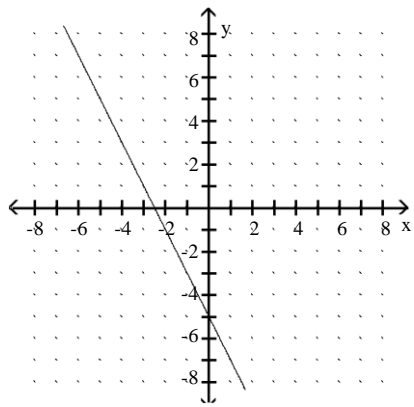

Answer: B

12) $y = -5x + 6$

A)

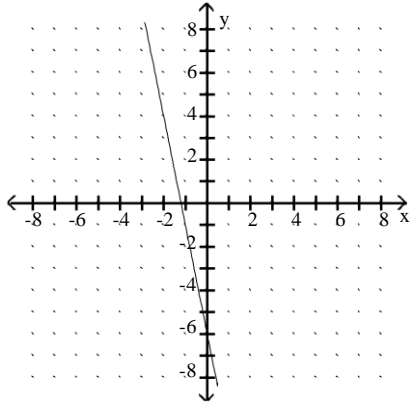

B)

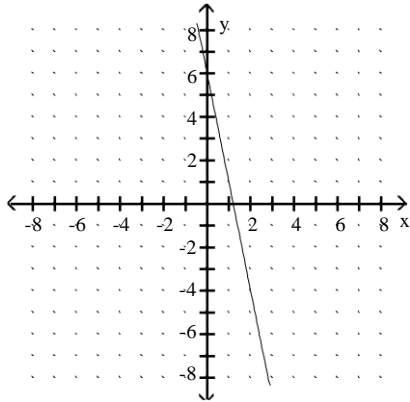

C)

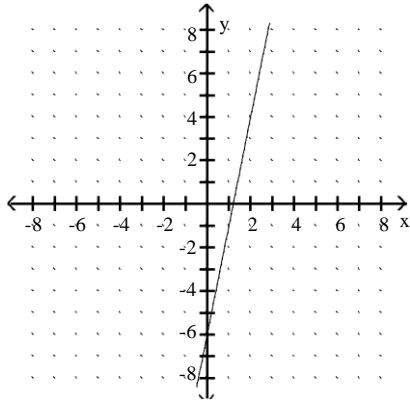

D)

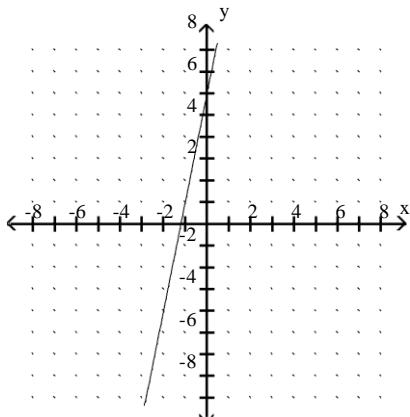

Answer: B

13) $y = -3x - 4$

A)

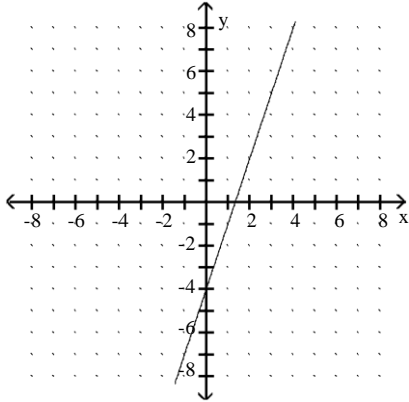

B)

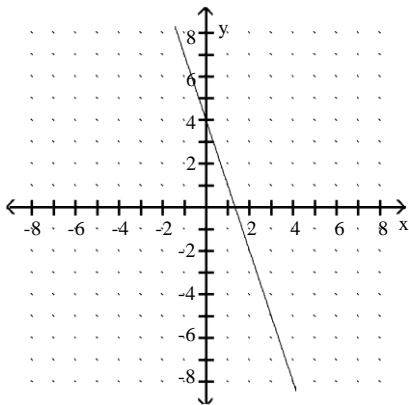

C)

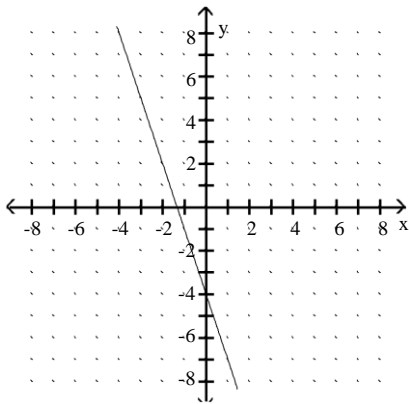

D)

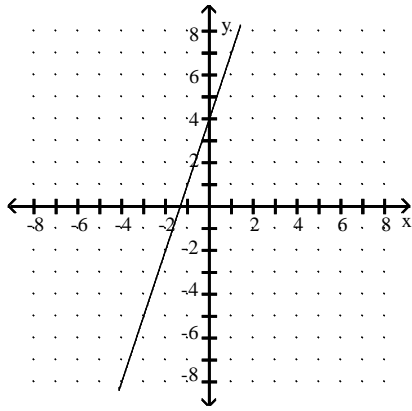

Answer: C

14) $y = -4x$

A)

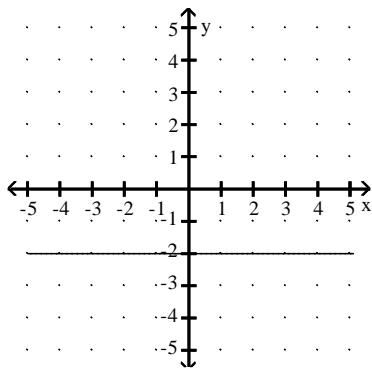

B)

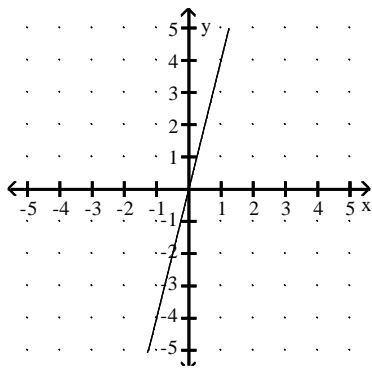

C)

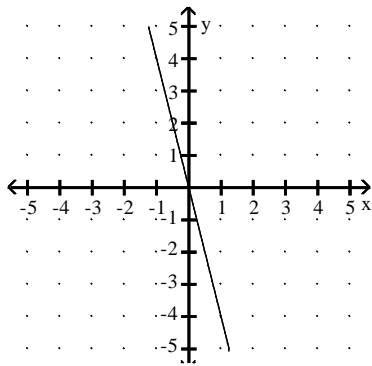

D)

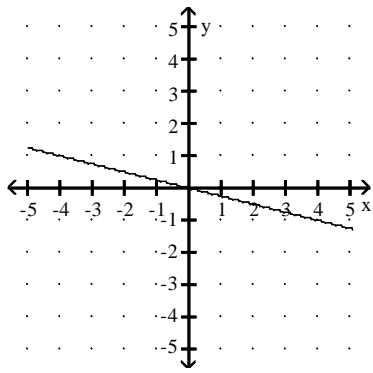

Answer: C

15) $y = -6$

A)

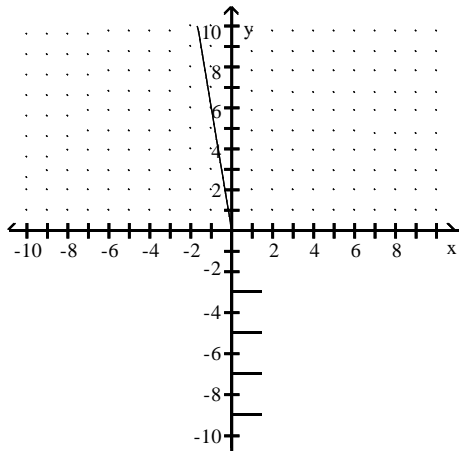

B)

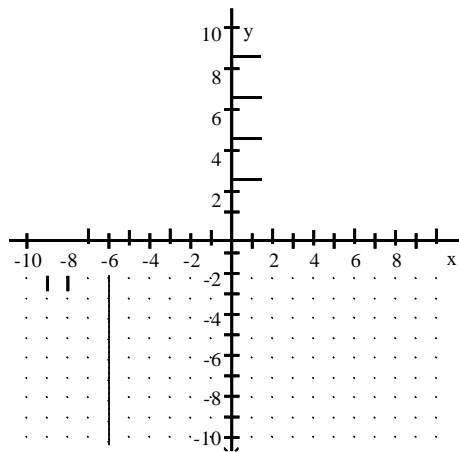

C)

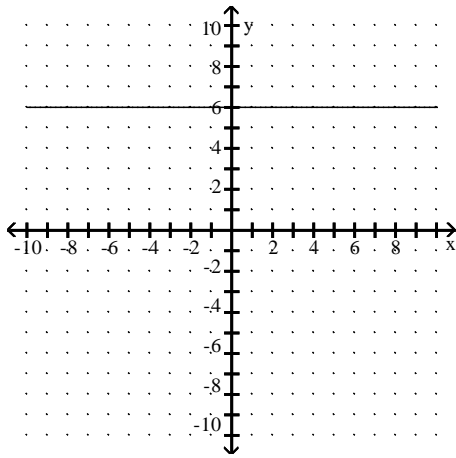

D)

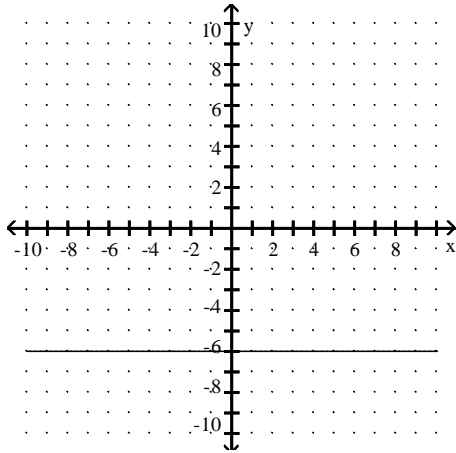

Answer: D

16) $y = 3(x - 2) + 6$

A)

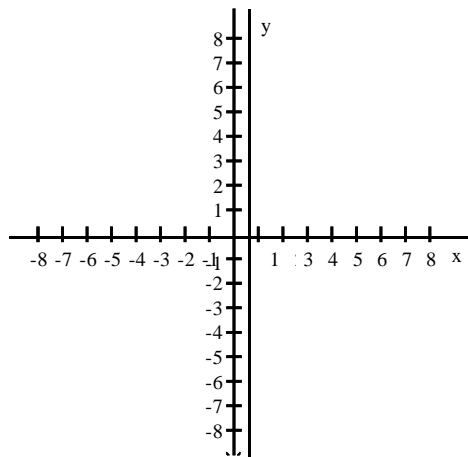

B)

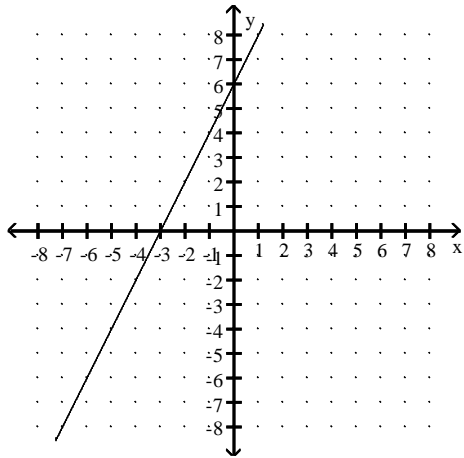

C)

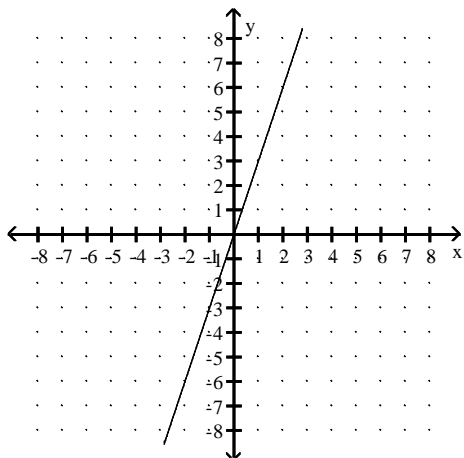

D)

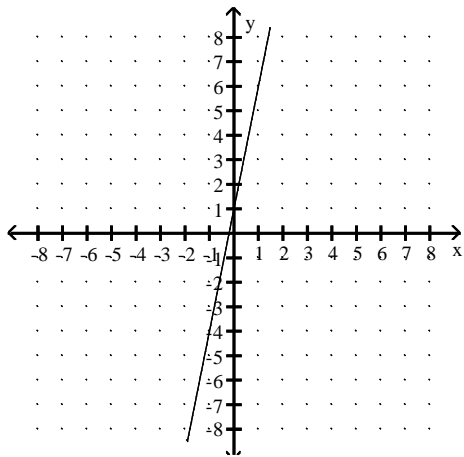

Answer: C

17) $x = 4$

A)

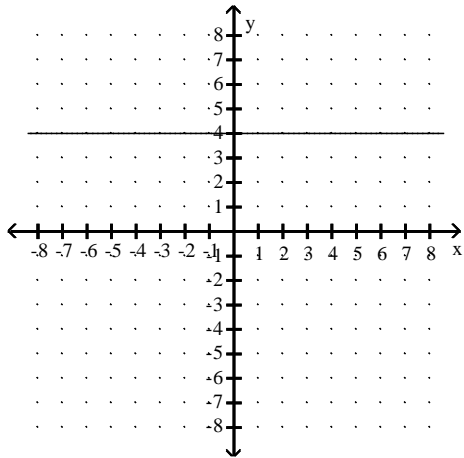

B)

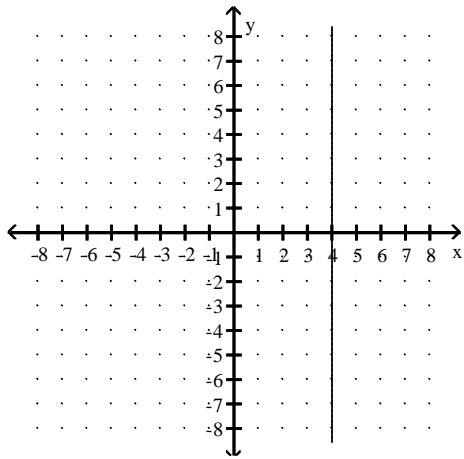

C)

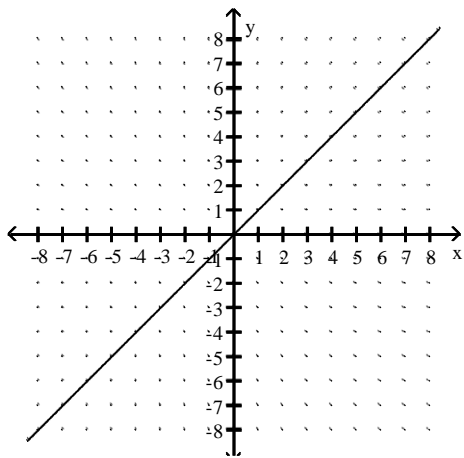

D)

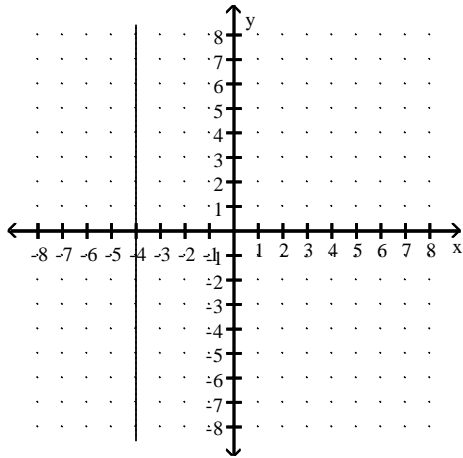

Answer: B

Write the slope-intercept form of the equation for the line passing through the given pair of points.

18) $(-3, -7)$ and $(0, -5)$

A) $y = -\frac{2}{3}x - 5$

B) $y = -\frac{4}{5}x - 5$

C) $y = \frac{2}{3}x - 5$

D) $y = \frac{4}{5}x - 5$

Answer: C

19) $(-7, 0)$ and $(4, 2)$

A) $y = -\frac{7}{2}x + 16$

B) $y = -\frac{2}{11}x + \frac{14}{11}$

C) $y = \frac{7}{2}x + 16$

D) $y = \frac{2}{11}x + \frac{14}{11}$

Answer: D

20) (3, -4) and (7, -7)

A) $y = -\frac{3}{4}x - \frac{7}{4}$

B) $y = \frac{1}{2}x - \frac{21}{2}$

C) $y = -\frac{1}{2}x - \frac{21}{2}$

D) $y = \frac{3}{4}x - \frac{7}{4}$

Answer: A

21) (10, -1) and (5, -4)

A) $y = -\frac{3}{5}x - 7$

B) $y = \frac{11}{9}x - \frac{91}{9}$

C) $y = \frac{3}{5}x - 7$

D) $y = -\frac{11}{9}x - \frac{91}{9}$

Answer: C

22) (-6, -5) and (-6, 5)

A) $x = -6$

B) $5x - 5y = 0$

C) $y = -5$

D) $-5x + 5y = 0$

Answer: A

23) (-6, 2) and (-5, 2)

A) $-5x - 6y = 0$

B) $-6x - 5y = 0$

C) $y = 2$

D) $x = -6$

Answer: C

24) (-5, -10) and (-8, -10)

A) $-8x - 5y = 0$

B) $x = -5$

C) $y = -10$

D) $-5x - 8y = 0$

Answer: C

25) y-intercept -9 and x-intercept -2

A) $y = -\frac{9}{2}x - 9$

B) $y = \frac{9}{2}x - 9$

C) $y = \frac{2}{9}x - 2$

D) $y = -\frac{2}{9}x - 2$

Answer: A

Write an equation of the line through the given point with the given slope. Write the equation in slope-intercept form.

26) (2, 5); slope: -3

A) $y = -3x - 11$

B) $y = -3x + 11$

C) $y = -\frac{1}{3}x + 11$

D) $y = -3x + \frac{1}{11}$

Answer: B

27) (4, 3); slope: $-\frac{3}{8}$

A) $y = -\frac{3}{8}x + \frac{9}{2}$

B) $y = -\frac{8}{3}x + \frac{9}{2}$

C) $y = -\frac{3}{8}x + \frac{2}{9}$

D) $y = -\frac{3}{8}x - \frac{9}{2}$

Answer: A

28) (3, 2); slope: $-\frac{4}{5}$

A) $y = -\frac{4}{5}x + \frac{22}{5}$

B) $y = -\frac{4}{5}x + \frac{5}{22}$

C) $y = -\frac{5}{4}x - \frac{5}{22}$

D) $y = -\frac{4}{5}x - \frac{22}{5}$

Answer: A

- 29) (1, -2); slope: 0
A) $x = 1$
B) $y = 2x + 0$
C) $y = -2$
D) $y = \frac{1}{2}x + 0$

Answer: C

- 30) (6, 0); slope: 7
A) $y = 7x - 42$
B) $y = -6x + 7$
C) $y = 6x + 7$
D) $y = -7x + 6$

Answer: A

- 31) (7, -3); slope: -4
A) $y = -4x + 25$
B) $y = 4x + 24$
C) $y = -4x + 26$
D) $y = -4x + 23$

Answer: A

- 32) (-8, 6); slope: -8
A) $y = -8x - 59$
B) $y = -8x - 58$
C) $y = 8x - 60$
D) $y = -8x - 66$

Answer: B

- 33) (7, -1); slope: $-\frac{3}{4}$
A) $y = -\frac{3}{4}x + \frac{25}{4}$
B) $y = -\frac{3}{4}x + 5$
C) $y = \frac{3}{4}x - \frac{17}{4}$
D) $y = -\frac{3}{4}x + \frac{17}{4}$

Answer: D

Find an equation of the line satisfying the following conditions.
If possible, write the equation in slope-intercept form.

- 34) y-intercept -22, slope
4.1

- A) $y = 4.1x - 22$
B) $y = -4.1x - 22$
C) $y = -22x + 4.1$
D) $y = 22x - 4.1$

Answer: A

35) y-intercept -29, x-intercept

25

A) $y = \frac{25}{29}x - 29$

B) $y = \frac{29}{25}x + 29$

C) $y = \frac{29}{25}x - 29$

D) $y = -\frac{29}{25}x - 29$

Answer: C

36) Through (4, 3), parallel to $5x + 9y = -7$

A) $y = -\frac{4}{9}x - \frac{7}{9}$

B) $y = -\frac{9}{5}x + \frac{3}{5}$

C) $y = \frac{5}{9}x - \frac{47}{9}$

D) $y = -\frac{5}{9}x + \frac{47}{9}$

Answer: D

37) Through (-6, -7), perpendicular to $-9x + 5y = 89$

A) $y = -\frac{9}{5}x - \frac{9}{5}$

B) $y = \frac{5}{9}x - \frac{31}{3}$

C) $y = -\frac{5}{9}x - \frac{31}{3}$

D) $y = -\frac{6}{5}x - \frac{89}{5}$

Answer: C

38) Through (1, 7), perpendicular to $x = 3$

A) $y = 3$

B) $x = 3$

C) $y = -7$

D) $y = 7$

Answer: D

39) Vertical, passing through (-4,

5) A) $x = -4$

B) $y = 5$

C) $y = -4$

D) $x = 5$

Answer: A

- 40) Vertical, passing through $(-8.66, -2.99)$
- A) $y = -2.99$
 - B) $y = -8.66$
 - C) $x = -8.66$
 - D) $x = -2.99$

Answer: C

- 41) Horizontal, passing through $(5, -2)$
- A) $y = -2$
 - B) $x = 5$
 - C) $x = -2$
 - D) $y = 5$

Answer: A

- 42) Horizontal, passing through $(-0.73, 8.27)$
- A) $x = 8.27$
 - B) $y = -0.73$
 - C) $x = -0.73$
 - D) $y = 8.27$

Answer: D

Determine the equation of the line described. Put the answer in the slope-intercept form, if possible.

- 43) Through $(-9, 2)$, perpendicular to $7x - 2y = -67$

- A) $y = \frac{2}{7}x + \frac{4}{7}$
- B) $y = -\frac{7}{2}x + 4$
- C) $y = -\frac{2}{7}x$
- D) $y = -\frac{2}{7}x - \frac{4}{7}$

Answer: D

- 44) Through $(1, 13)$, parallel to $2x - 5y = -38$

- A) $y = -\frac{2}{5}x - \frac{63}{5}$
- B) $y = \frac{5}{2}x + \frac{13}{2}$
- C) $y = \frac{1}{5}x + \frac{38}{5}$
- D) $y = \frac{2}{5}x + \frac{63}{5}$

Answer: D

45) Through $(-8, 1)$, perpendicular to $6x + 5y = -53$

A) $y = -\frac{8}{5}x + \frac{53}{5}$

B) $y = \frac{6}{5}x + \frac{6}{5}$

C) $y = -\frac{5}{6}x + \frac{23}{3}$

D) $y = \frac{5}{6}x + \frac{23}{3}$

Answer: D

46) Through $(8, -8)$, perpendicular to $-8x + 3y = -88$

A) $y = -\frac{3}{8}x - 5$

B) $y = -\frac{8}{3}x - 40$

C) $y = \frac{3}{8}x + 5$

D) $y = -\frac{3}{8}x$

Answer: A

47) Through $(2, 5)$, perpendicular to $x = 8$

A) $x = 8$

B) $y = 5$

C) $y = -5$

D) $y = 8$

Answer: B

48) Through $(7, 6)$, perpendicular to $y = \frac{3}{7}x - 3$

A) $y = -\frac{7}{3}x + \frac{1}{3}$

B) $y = -\frac{7}{3}x + \frac{67}{3}$

C) $y = -\frac{3}{7}x - \frac{67}{7}$

D) $y = \frac{7}{3}x - \frac{67}{3}$

Answer: B

49) Through $(5, -4)$, perpendicular to $x = -6$

A) $y = 4$

B) $x = -6$

C) $y = -6$

D) $y = -4$

Answer: D

Find an equation of the line satisfying the following conditions. If possible, write the equation in slope-intercept form.

50) Vertical, passing through (9, 3)

- A) $x = 9$
- B) $x = 3$
- C) $y = 3$
- D) $y = 9$

Answer: A

51) Vertical, passing through (-8.34, -3.58)

- A) $x = -8.34$
- B) $y = -8.34$
- C) $x = -3.58$
- D) $y = -3.58$

Answer: A

52) Horizontal, passing through (-8,

- A) $x = -8$
- B) $y = -8$
- C) $y = 6$
- D) $x = 6$

Answer: C

53) Horizontal, passing through (2.19, -5.83)

- A) $x = 2.19$
- B) $y = -5.83$
- C) $y = 2.19$
- D) $x = -5.83$

Answer: B

54) Horizontal, passing through (-10,

- A) $x = -10$
- B) $x = -8$
- C) $y = 8$
- D) $y = 10$

Answer: C

Determine the x- and y-intercepts on the graph of the equation.

55) $y = 4x + 3$

- A) x-intercept is 3; y-intercept is $\frac{3}{4}$
- B) x-intercept is $\frac{3}{4}$; y-intercept is 3
- C) x-intercept is $-\frac{4}{3}$; y-intercept is 4
- D) x-intercept is $-\frac{3}{4}$; y-intercept is 3

Answer: D

56) $y = -2x$

- A) x-intercept is -2; y-intercept is 0
- B) x-intercept is 0; y-intercept is 0
- C) x-intercept is 0; y-intercept is -2
- D) x-intercept is 1; y-intercept is 2

Answer: B

57) $y = x + 7$

- A) x-intercept is 7; y-intercept is -7
- B) x-intercept is 1; y-intercept is 7
- C) x-intercept is -7; y-intercept is 7
- D) x-intercept is 0; y-intercept is 0

Answer: C

58) $y = -7x - 1$

- A) x-intercept is $-\frac{1}{7}$; y-intercept is -1
- B) x-intercept is $\frac{1}{7}$; y-intercept is -7
- C) x-intercept is -1; y-intercept is $\frac{1}{7}$
- D) x-intercept is $\frac{1}{7}$; y-intercept is $\frac{1}{7}$

Answer: A

59) $y = 9.3x - 93$

- A) x-intercept is 9.3; y-intercept is 9.3
- B) x-intercept is 93; y-intercept is -93
- C) x-intercept is -10; y-intercept is 93
- D) x-intercept is 10; y-intercept is -93

Answer: D

60) $y = 7.5x + 30$

- A) x-intercept is 4; y-intercept is -30
- B) x-intercept is -7.5; y-intercept is 7.5
- C) x-intercept is -4; y-intercept is 30
- D) x-intercept is -30; y-intercept is -4

Answer: C

61) $y = 17(x + 3) - 4$

A) x-intercept is $-\frac{55}{17}$; y-intercept is -47

B) x-intercept is $\frac{47}{17}$; y-intercept is 47

C) x-intercept is 47 ; y-intercept is 55

D) x-intercept is $-\frac{47}{17}$; y-intercept is 47

Answer: D

62) $y = -7(x - 1) - 1$

A) x-intercept is $\frac{6}{7}$; y-intercept is $\frac{8}{7}$

B) x-intercept is $\frac{8}{7}$; y-intercept is $\frac{6}{7}$

C) x-intercept is $\frac{6}{7}$; y-intercept is $\frac{6}{7}$

D) x-intercept is $-\frac{6}{7}$; y-intercept is $-\frac{6}{7}$

Answer: C

63) $y = -11(x - 1) + 2$

A) x-intercept is $-\frac{13}{11}$; y-intercept is -13

B) x-intercept is $\frac{13}{11}$; y-intercept is $\frac{13}{11}$

C) x-intercept is $-\frac{9}{11}$; y-intercept is 13

D) x-intercept is $\frac{9}{11}$; y-intercept is 9

Answer: B

64) $y = 13(x + 4) + 1$

A) x-intercept is $-\frac{53}{13}$; y-intercept is $-\frac{53}{13}$

B) x-intercept is $\frac{53}{13}$; y-intercept is $\frac{51}{13}$

C) x-intercept is $\frac{53}{13}$; y-intercept is $-\frac{53}{13}$

D) x-intercept is $-\frac{53}{13}$; y-intercept is $\frac{53}{13}$

Answer: D

The table lists data that are exactly linear. (i) Find the slope-intercept form of the line that passes through these data points. (ii) Predict y when $x = -1.5$ and 4.6 .

65)

x	-2	-1	0	1	2
y	4.2	6.6	9.0	11.4	13.8

A) $y = -2.4x - 9$; $y = -5.4$, $y = -20.04$

B) $y = 2.4x + 9$; $y = 5.40$, $y = 20.04$

C) $y = -2.4x + 9$; $y = 12.6$, $y = -2.04$

D) $y = 2.4x - 9$; $y = -12.6$, $y = 2.04$

Answer: B

66)
$$\begin{array}{c|ccccc} x & -2 & -1 & 0 & 1 & 2 \\ \hline y & 3.5 & 4.2 & 4.9 & 5.6 & 6.3 \end{array}$$

A) $y = -0.7x - 4.9$; $y = -3.85$, $y = -8.12$
 B) $y = 0.7x + 4.9$; $y = 3.85$, $y = 8.12$
 C) $y = -0.7x + 4.9$; $y = 5.95$, $y = 1.68$
 D) $y = 0.7x - 4.9$; $y = -5.95$, $y = -1.68$

Answer: B

67)
$$\begin{array}{c|ccccc} x & -3 & -2 & -1 & 0 & 1 \\ \hline y & 7.2 & 8.1 & 9.0 & 9.9 & 10.8 \end{array}$$

A) $y = -0.9x + 9.9$; $y = 11.25$, $y = 5.76$
 B) $y = 0.9x + 9.9$; $y = 8.55$, $y = 14.04$
 C) $y = -0.9x + 9$; $y = 7.65$, $y = 13.14$
 D) $y = -9.9x + 9.9$; $y = 4.95$, $y = 55.44$

Answer: B

68)
$$\begin{array}{c|ccccc} x & -4 & -3 & -2 & -1 & 0 \\ \hline y & -7.2 & -4.0 & -0.8 & 2.4 & 5.6 \end{array}$$

A) $y = 3.2x + 2.4$; $y = -2.4$, $y = 17.12$
 B) $y = 3.2x + 5.6$; $y = 0.8$, $y = 20.32$
 C) $y = 3.2x - 7.2$; $y = -12$, $y = 7.52$
 D) $y = 3.2x - 4$; $y = -8.8$, $y = 10.72$

Answer: B

69)
$$\begin{array}{c|ccccc} x & -4 & -3 & -2 & -1 & 0 \\ \hline y & -1.7 & 1.1 & 3.9 & 6.7 & 9.5 \end{array}$$

A) $y = 2.8x - 1.7$; $y = -5.9$, $y = 11.18$
 B) $y = -2.8x + 9.5$; $y = 13.7$, $y = -3.38$
 C) $y = 2.8x + 9.5$; $y = 5.3$, $y = 22.38$
 D) $y = 2.8x - 9.5$; $y = -13.7$, $y = 3.38$

Answer: C

70)
$$\begin{array}{c|ccccc} x & 3 & 16 & 33 & 44 & 55 \\ \hline y & 86.4 & 56.5 & 17.4 & -7.9 & - \end{array}$$

A) $y = -2.3x + 93.3$; $y = 96.75$, $y = 82.72$
 B) $y = 4.6x + 93.3$; $y = -100.2$, $y = -72.14$
 C) $y = -4.6x + 93.3$; $y = 100.2$, $y = 72.14$
 D) $y = 2.3x + 93.3$; $y = 89.85$, $y = 103.88$

Answer: A

71)
$$\begin{array}{c|ccccc} x & -19 & -17 & -8 & 5 & 9 \\ \hline y & -51 & -44.2 & -13.6 & 30.6 & \end{array}$$

A) $y = -3.4x - 13.6$; $y = -8.5$, $y = -29.24$
 B) $y = 6.4x + 13.6$; $y = 4$, $y = 43.04$
 C) $y = 2.4x + 13.6$; $y = 10$, $y = 24.64$
 D) $y = 3.4x + 13.6$; $y = 8.5$, $y = 29.24$

Answer: D

72)
$$\begin{array}{c|cccc} x & -28 & -21 & -10 & -9 & -1 \\ \hline y & -208.4 & -146.1 & -48.2 & -39.3 & \end{array}$$

- A) $y = 4.9x + 40.8$; $y = 33.45$, $y = 63.34$
- B) $y = -8.9x - 40.8$; $y = -27.45$, $y = -81.74$
- C) $y = 10.9x + 40.8$; $y = 24.45$, $y = 90.94$
- D) $y = 8.9x + 40.8$; $y = 27.45$, $y = 81.74$

Answer: D

Solve the problem.

73)

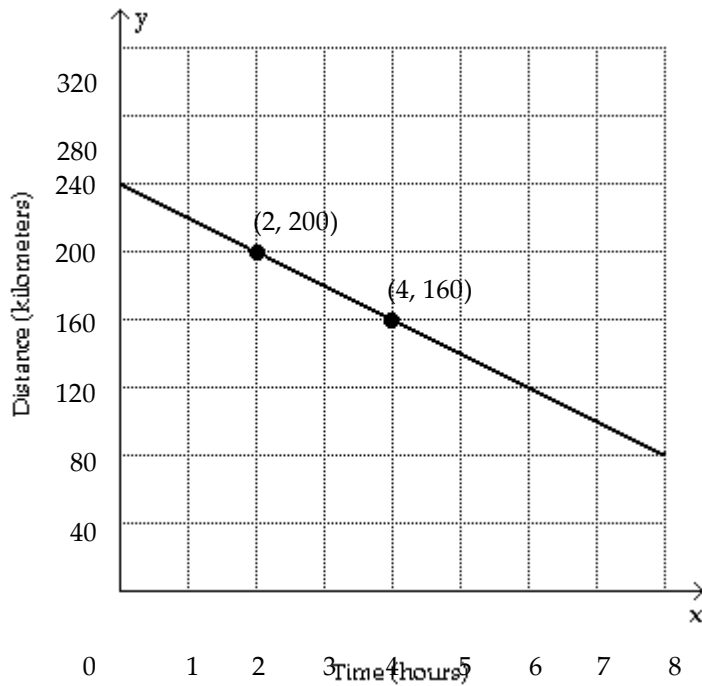

Abbey is driving a delivery truck on a straight road. The graph shows the distance y in kilometers that Abbey is from Store A after x hours. (i) Is Abbey traveling toward or away from Store A? (ii) Find the slope of the line.

- A) Away; slope is 80.
- B) Toward; slope is -20 .
- C) Toward; slope is -40 .
- D) Away; slope is 20.

Answer: B

74)

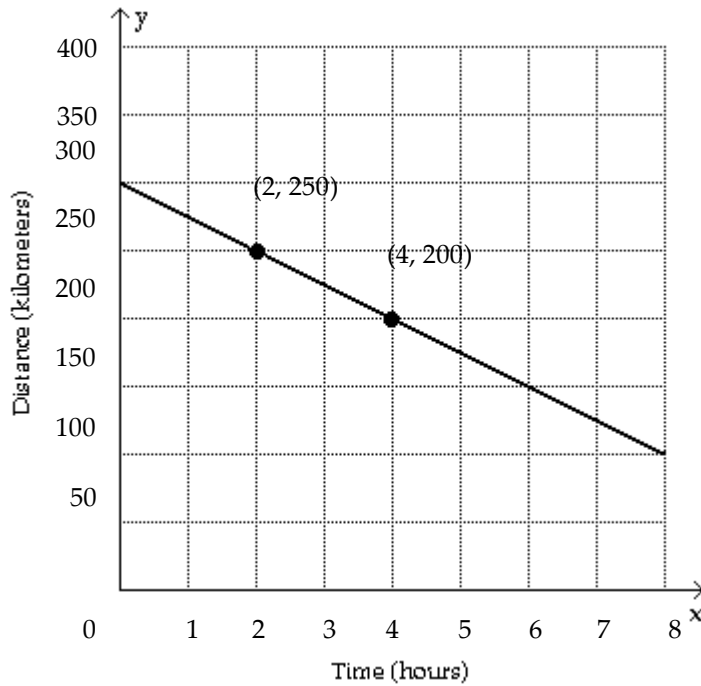

Abbey is driving a delivery truck on a straight road. The graph shows the distance y in kilometers that Abbey is from Store A after x hours. (i) Find the slope-intercept form of the equation of the line. (ii) Use the graph to estimate the y -coordinate of the point $(6, y)$ that lies on the line.

- A) $y = 25x + 300$; $(6, 450)$
- B) $y = -50x + 300$; $(6, 0)$
- C) $y = -25x + 300$; $(6, 150)$
- D) $y = 25x - 300$; $(6, -$

150) Answer: C

75)

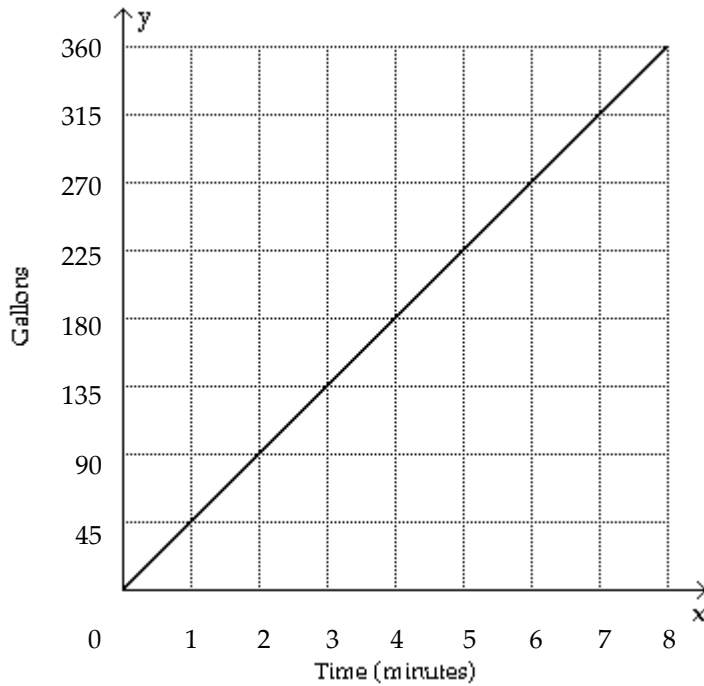

The graph shows the amount of water in a 450-gallon tank after x minutes have elapsed. (i) Is the water entering or leaving the tank? (ii) Find the x -intercept and the y -intercept.

- A) Leaving; both intercepts are 0
- B) Leaving; x -intercept is 0 and y -intercept is 450
- C) Entering; both intercepts are 0
- D) Entering; x -intercept is 450 and y -intercept is 0

Answer: C

76)

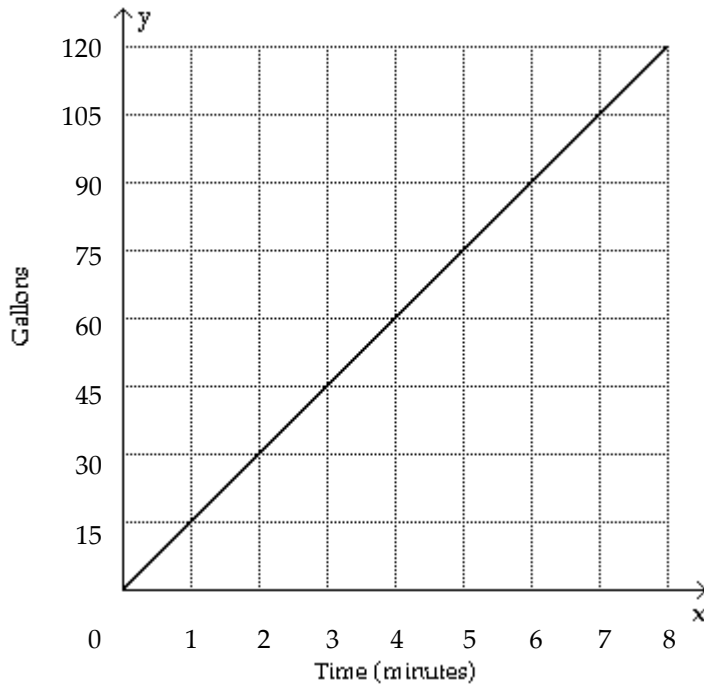

The graph shows the amount of oil in a 150-gallon tank after x minutes have elapsed. (i) Find the slope-intercept form of the equation of the line. (ii) Use the graph to estimate the x -coordinate of the point

$(x, 30)$ that lies on the line..

- A) $y = -15x$; (2, -30)
- B) $y = 15x$; (2, 30)
- C) $y = 15x - 2$; (0, 30)
- D) $y = 15x + 2$; (2, 32)

Answer: B

77)

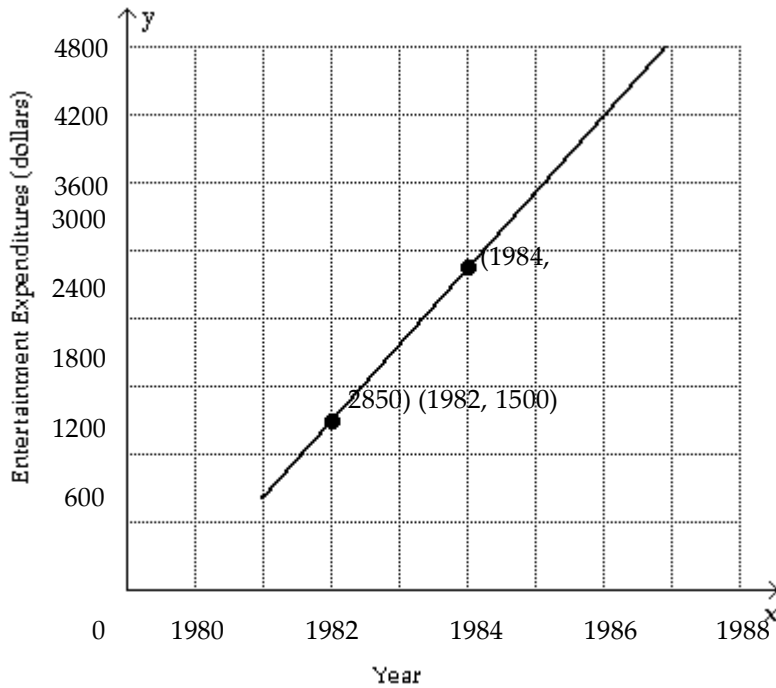

The graph models the average amount spent annually on entertainment per household in Country X from 1981 to 1987. (i) Find the slope of the line. (ii) Find a point-slope form for the line. (Answers may vary.)

- A) Slope is 525; point-slope form is $y = 525(x - 1984) + 2850$.
 B) Slope is 825; point-slope form is $y = 825(x - 1984) + 2850$.
 C) Slope is 675; point-slope form is $y = 675(x - 1982) + 1500$.
 D) Slope is 375; point-slope form is $y = 375(x - 1982) + 1500$.

Answer: C

78) In 1990 the number of factory pollution incidents reported in Country X was 7500. This number had decreased roughly at a rate of 440 per year since 1982. (i) Find an equation of a line $y = m(x - h) + k$ that describes this data, where y represents the number of pollution incidents during the year x . (Answers may vary.) (ii) Estimate the year when there were approximately 8250 incidents.

- A) $y = -7500(x - 1990) + 440$; 1983
 B) $y = -440(x - 1982) + 7500$; 1980
 C) $y = -440(x - 1988) + 7500$; 1986
 D) $y = -440(x - 1990) + 7500$; 1988

Answer: D

- 79) The cost of owning a home includes both fixed costs and variable utility costs. Assume that it costs \$2098 per month for mortgage and insurance payments and it costs an average of \$2.87 per unit for natural gas, electricity, and water usage. (i) Determine a linear function that computes the annual cost of owning this home if x utility units are used. (ii) What does the y -intercept on the graph of the function represent?
- A) $y = -2.87x + 25,176$; y -intercept, 25,176, represents the minimum cost of owning the home for 12 months without spending anything on utilities.
 - B) $y = 2.87x + 2098$; y -intercept, 2098, represents the minimum cost of owning the home without spending anything on utilities.
 - C) $y = 2.87x + 25,176$; y -intercept, 25,176, represents the minimum cost of owning the home for 12 months without spending anything on utilities.
 - D) $y = -2.87x + 2098$; y -intercept, 2098, represents the minimum cost of owning the home without spending anything on utilities.

Answer: C

Solve the problem using your calculator.

- 80) Ten students in a graduate program were randomly selected. Their grade point averages (GPAs) when they entered the program were between 3.5 and 4.0. The following data were obtained regarding their GPAs on entering the program versus their current GPAs. Use linear regression to find a linear function that predicts a student's current GPA as a function of his or her entering GPA.

<u>EnteringGPA</u>	<u>CurrentGPA</u>
3.5	3.6
3.8	3.7
3.6	3.9
3.6	3.6
3.5	3.9
3.9	3.8
4.0	3.7
3.9	3.9
3.5	3.8
3.7	4.0

- A) $y = 3.67 + 0.0313x$
- B) $y = 5.81 + 0.497x$
- C) $y = 2.51 + 0.329x$
- D) $y = 4.91 + 0.0212x$

Answer: A

- 81) The paired data below consist of the test scores of 6 randomly selected students and the number of hours they studied for the test. Use linear regression to find a linear function that predicts a student's score as a function of the number of hours he or she studied.

Hours	5	10	4	6	10	9
Score	64	86	69	86	59	87

- A) $y = 33.7 + 2.14x$
- B) $y = 33.7 - 2.14x$
- C) $y = 67.3 + 1.07x$
- D) $y = -67.3 + 1.07x$

Answer: C

- 82) The paired data below consist of the costs of advertising (in thousands of dollars) and the number of products sold (in thousands). Use linear regression to find a linear function that predicts the number of products sold as a function of the cost of advertising.

Cost	9	2	3	4	2	5	9	10
Number	85	52	55	68	67	86	83	73

- A) $y = 55.8 - 2.79x$
 B) $y = 55.8 + 2.79x$
 C) $y = -26.4 - 1.42x$
 D) $y = 26.4 + 1.42x$

Answer: B

- 83) The paired data below consist of the temperatures on randomly chosen days and the amount a certain kind of plant grew (in millimeters). Use linear regression to find a linear function that predicts a plant's growth as a function of temperature.

Temp	62	76	50	51	71	46	51	44	79
Growth	36	39	50	13	33	33	17	6	16

- A) $y = -14.6 - 0.211x$
 B) $y = 7.30 + 0.122x$
 C) $y = 14.6 + 0.211x$
 D) $y = 7.30 - 0.112x$

Answer: C

- 84) A study was conducted to compare the average time spent in the lab each week versus course grade for computer students. The results are recorded in the table below. Use linear regression to find a linear function that predicts a student's course grade as a function of the number of hours spent in lab.

<u>Numberofhoursspentinlab</u>	<u>Grade(percent)</u>
10	96
11	51
16	62
9	58
7	89
15	81
16	46
10	51

- A) $y = 1.86 + 88.6x$
 B) $y = 0.930 + 44.3x$
 C) $y = 44.3 + 0.930x$
 D) $y = 88.6 - 1.86x$

Answer: D

- 85) Two separate tests are designed to measure a student's ability to solve problems. Several students are randomly selected to take both tests and the results are shown below. Use linear regression to find a linear function that predicts a student's score on Test B as a function of his or her score on Test A.

Test A	48	52	58	44	43	43	40	51	59
Test B	73	67	73	59	58	56	58	64	74

- A) $y = -0.930 + 19.4x$
 B) $y = 19.4 + 0.930x$
 C) $y = 0.930 - 19.4x$
 D) $y = -19.4 - 0.930x$

Answer: B

Solve the problem.

- 86) Ten students in a graduate program were randomly selected. Their grade point averages (GPAs) when they entered the program were between 3.5 and 4.0. The following data were obtained regarding their GPAs on entering the program versus their current GPAs. By using linear regression, the following function is obtained: $y = 3.67 + 0.0313x$ where x is entering GPA and y is current GPA. Use this function to predict current GPA of a student whose entering GPA is 3.8. Round to the nearest hundredth.

EnteringGPA	CurrentGPA
3.5	3.6
3.8	3.7
3.6	3.9
3.6	3.6
3.5	3.9
3.9	3.8
4.0	3.7
3.9	3.9
3.5	3.8
3.7	4.0

- A) 3.30
 B) 3.59
 C) 3.41
 D) 3.79

Answer: D

- 87) The paired data below consist of the test scores of 6 randomly selected students and the number of hours they studied for the test. By using linear regression, the following function is obtained: $y = 67.3 + 1.07x$ where x is number of hours studied and y is score on the test. Use this function to predict the score on the test of a student who studies 11 hours. Round to the nearest tenth.

Hours	5	10	4	6	10	9
Score	64	86	69	86	59	87

- A) 74.1
 B) 79.1
 C) 84.1
 D) 83.8

Answer: B

88) The paired data below consist of the costs of advertising (in thousands of dollars) and the number of products sold (in thousands). By using linear regression, the following function is obtained: $y = 55.8 + 2.79x$ where x is the cost of advertising (in thousands of dollars) and y is number of products sold (in thousands). Use this function to predict the number of products sold if the cost of advertising is \$7000. Round to the nearest hundredth.

Cost	9	2	3	4	2	5	9	10
Number	85	52	55	68	67	86	83	73

- A) 72.33
- B) 75.33
- C) 19,585.8
- D) 82.03

Answer: B

89) The paired data below consist of the temperatures on randomly chosen days and the amount a certain kind of plant grew (in millimeters). By using linear regression, the following function is obtained: $y = 14.6 + 0.211x$ where x is temperature and y is growth in millimeters. Use this function to predict the growth of a plant if the temperature is 69. Round to the nearest hundredth.

Temp	62	76	50	51	71	46	51	44	79
Growth	36	39	50	13	33	33	17	6	16

- A) 27.71
- B) 29.16
- C) 30.26
- D) 29.71

Answer: B

90) A study was conducted to compare the average time spent in the lab each week versus course grade for computer students. The results are recorded in the table below. By using linear regression, the following function is obtained: $y = 88.6 - 1.86x$ where x is the number of hours spent in the lab and y is the grade on the test. Use this function to predict the grade of a student who spends 14 hours in the lab. Round to the nearest tenth.

Numberofhoursspentinlab	Grade(percent)
10	96
11	51
16	62
9	58
7	89
15	81
16	46
10	51

- A) 74.6
- B) 65.4
- C) 58.6
- D) 62.6

Answer: D

Identify the equation as either linear or nonlinear by trying to write it in the form $ax + b = 0$.

91) $3x + 2 = 0.2$

- A) Linear
- B) Nonlinear

Answer: A

92) $45 + 155x = 109x$

A) Nonlinear

B) Linear

Answer: B

93) $5x^2 - 2.3x = x^2 - 2$

A) Linear

B) Nonlinear

Answer: B

94) $x^2 + 8x = x^3 + 1$

A) Nonlinear

B) Linear

Answer: A

95) $8x + 17 = 2(x - 4) - x$

A) Nonlinear

B) Linear

Answer: B

96) $8x^2 - 3x = 8(x^2 + 9) - 9x$

A) Linear

B) Nonlinear

Answer: A

97) $6x^3 - 5x^2 = 4(x^3 - 7) - x^2 + 5x$

A) Nonlinear

B) Linear

Answer: A

98) $x^3 - 4x = 6x^2 - (x + 4) + 12$

A) Nonlinear

B) Linear

Answer: A

Solve the equation symbolically.

99) $21x - 2 = 13$

A) $\frac{11}{21}$

B) $\frac{5}{7}$

C) $\frac{2}{3}$

D) $-\frac{5}{7}$

Answer: B

100) $29t + 4 = 4t + 14$

A) $\frac{11}{3}$

B) $-\frac{2}{5}$

C) $\frac{11}{6}$

D) $\frac{2}{5}$

Answer: D

101) $9x - (3x - 1) = 2$

A) $-\frac{1}{6}$

B) $\frac{1}{12}$

C) $-\frac{1}{12}$

D) $\frac{1}{6}$

Answer: D

102) $\frac{1}{2}(6x - 10) = \frac{1}{3}(15x - 9)$

A) -1

B) $\frac{1}{15}$

C) 1

D) -15

Answer: A

103) $4(2x - 1) = 16$

A) $\frac{15}{8}$

B) $\frac{17}{8}$

C) $\frac{3}{2}$

D) $\frac{5}{2}$

Answer: D

104) $\frac{1}{4}p - \frac{3}{8}p = 4$

- A) -28
- B) 32
- C) -32
- D) 28

Answer: C

105) $\frac{x+6}{7} = \frac{x+7}{8}$

- A) $\frac{1}{56}$
- B) $\frac{13}{56}$
- C) $\frac{13}{15}$
- D) 1

Answer: D

106) $\frac{8x-2}{3} + \frac{7x+9}{3} = -\frac{7}{5}$

- A) $-\frac{112}{225}$
- B) $-\frac{56}{75}$
- C) $\frac{14}{75}$
- D) $\frac{34}{75}$

Answer: B

107) $x^2 + 6x + 6 = x^2 - 3$

- A) No solution
- B) $-\frac{3}{2}$
- C) All real numbers
- D) $\frac{13}{6}$

Answer: B

108) $3x^2 + 7x - 5 = x(7 + 3x) - 5$

- A) No solution
- B) -4
- C) 4
- D) All real numbers

Answer: D

Classify the equation as a contradiction, an identity, or a conditional equation.

109) $40m + 25 = 5(3m -$

- 20) A) Identity
- B) Conditional
- C) Contradiction

Answer: B

110) $3(50t + 25) = 15(5t -$

- 5) A) Contradiction
- B) Identity
- C) Conditional

Answer: C

111) $2(2f + 20) = 4f + 40$

- A) Conditional
- B) Identity
- C) Contradiction

Answer: B

112) $2(5g + 9) - 10g - 18 =$
 0

- A) Contradiction
- B) Identity
- C) Conditional

Answer: B

113) $12k + 89 = 3(4k +$
 $29)$ A)

- Conditional
- B) Contradiction
- C) Identity

Answer: B

114) $-12s - 18 + 3(4s + 9) =$
 0

- A) Identity
- B) Contradiction
- C) Conditional

Answer: B

Solve the problem.

115) Let y_1 equal the left side and let y_2 equal the right side of the given equation. Graph y_1 and y_2 and use the graph to solve the equation $x - 3 = -2$.

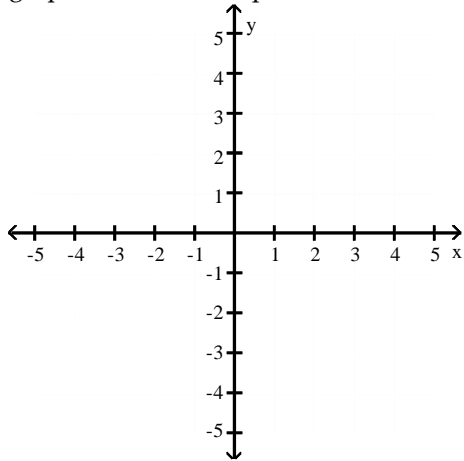

A)

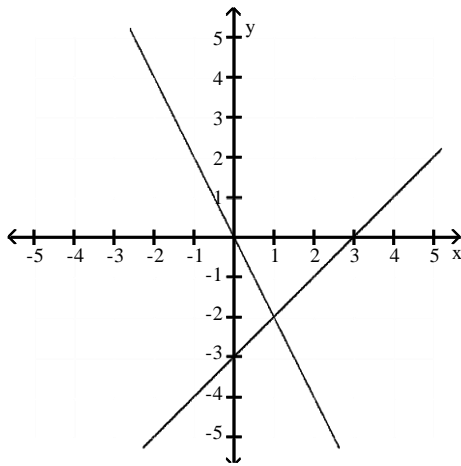

$x = 1$

B)

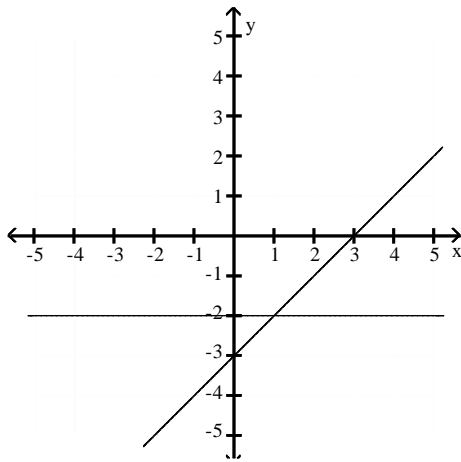

$x = 1$

C)

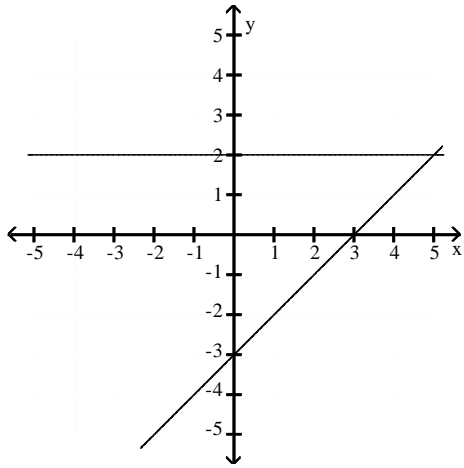

$x = 5$

D)

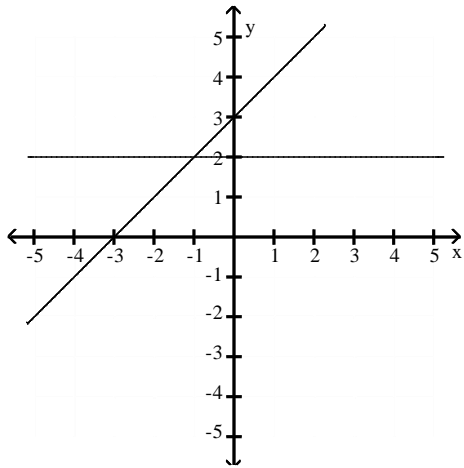

$x = -1$

Answer: B

116) Let y_1 equal the left side and let y_2 equal the right side of the given equation. Graph y_1 and y_2 and use the graph to solve the equation $x + 2 = 4 - x$.

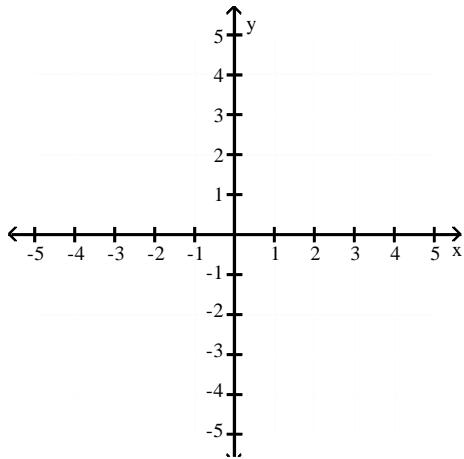

A)

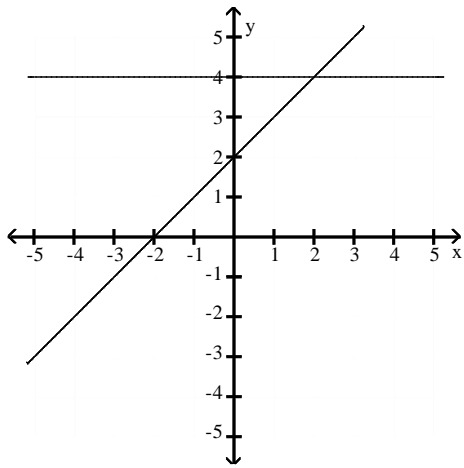

$x = 2$

B)

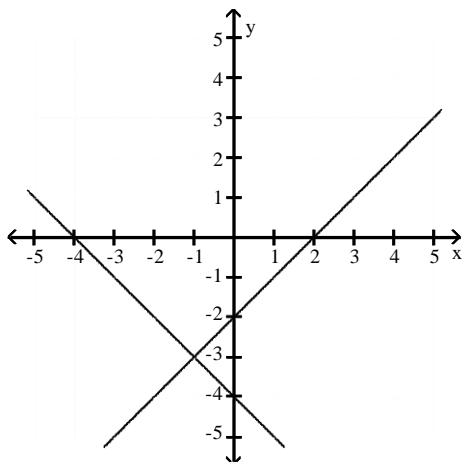

$x = -1$

C)

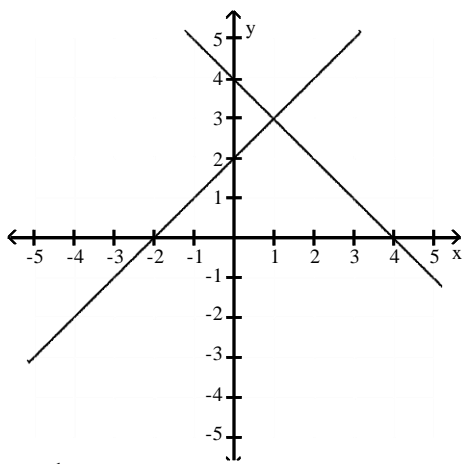

$x = 1$

D)

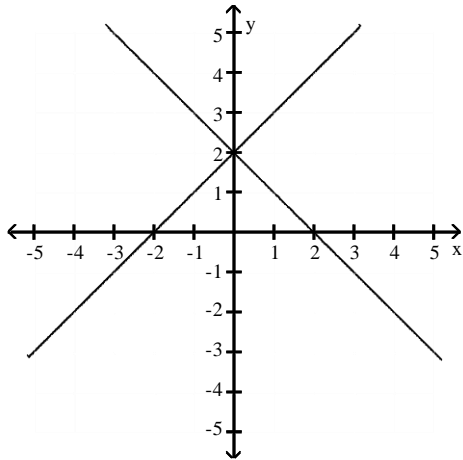

$$x = 0$$

Answer: C

Solve the linear equation with the intersection-of-graphs method. Approximate the solution to the nearest hundredth if necessary.

117) $9x + 9.2 = -0.4$

- A) 1.04
- B) 1.07
- C) -1.07
- D) 0.98

Answer: C

118) $\sqrt{3}x = 3x - 7.1$

- A) -1.5
- B) 5.6
- C) -5.6
- D) 1.5

Answer: B

119) $9.9(x - 1) = \frac{1}{2}x - 2.1$

- A) 0.83
- B) 0.75
- C) -1.15
- D) -1.28

Answer: A

120) $\frac{3+x}{-2} = \frac{-6x-7}{2}$

- A) 1.67
- B) -2
- C) 1.43
- D) -0.8

Answer: D

121) $\sqrt{7}(1 + 2.4x) = 2.4(x + 4.2^2)$ A) 4.54
 B) 5.14
 C) 11.39
 D) 10.05

Answer: D

122) $7.8(x + 1.5) = 6.9(-9.5 + 9x) + -0.2$
 A) 1.42
 B) 1
 C) -1.11
 D) 1.43

Answer: D

Solve the equation. Round your answer to the nearest tenth.

123) $-3.9q + 1.9 = -23.4 - 1.6q$
 A) 6.5
 B) 6.9
 C) -28
 D) 11

Answer: D

124) $2x + \frac{1}{5} = \frac{x-7}{3}$
 A) -1.9
 B) -1.2
 C) -1.5
 D) -0.3

Answer: C

125) $\pi - 2.4x = \frac{4x - \sqrt{3}}{8} +$
 A) 0.3
 B) -0.9
 C) -0.5
 D) 0.6

Answer: A

Solve the problem.

126) Median family income in Country X between 1990 and 1999 can be modeled by $f(x) = 1122.3(x - 1990) + 35,894$, where x is the year. Determine symbolically when the median income was \$42,754.
 A) $x \approx 1994$
 B) $x \approx 1998$
 C) $x \approx 1996$

Answer: C

- 127) The relation between escape velocity, v_e , and orbital velocity, v_c , is described by the equation $v_e = 2v_c$. If a spacecraft requires a velocity of 82,500 miles per hour in order to escape the gravitational pull of Planet A, what velocity is needed to travel in a circular orbit around Planet A? Round to the nearest hundredth.
- A) 116,672.62 miles per hour
 - B) 406.2 miles per hour
 - C) 58,336.31 miles per hour
 - D) 82,498.59 miles per hour

Answer: C

- 128) Brand A soup contains 873 milligrams of sodium. Find a linear function f that computes the number of milligrams of sodium in x cans of Brand A soup.
- A) $f(x) = 873$
 - B) $f(x) = x - 873$
 - C) $f(x) = 873x$
 - D) $f(x) = 873 + x$

Answer: C

- 129) Brand A soup contains 854 milligrams of sodium. It is recommended that a person requiring 2000 calories daily consume 2500 mg of sodium or less per day. Graph the function, f , that computes the number of mg of sodium in x cans of soup together with $y_1 = 2500$, $y_2 = 5000$, $y_3 = 7500$ in $[0, 10, 1]$ by $[0, 8000, 1000]$. Use the intersection-of-graphs method to find how many cans of soup contain 1, 2, and 3 daily allowances of sodium.

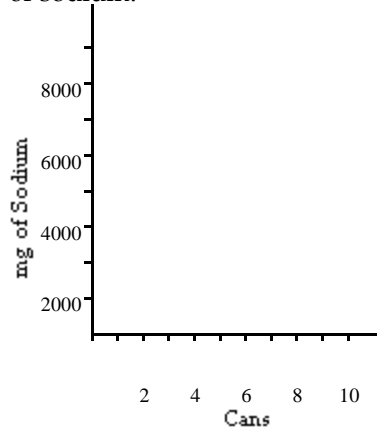

A)

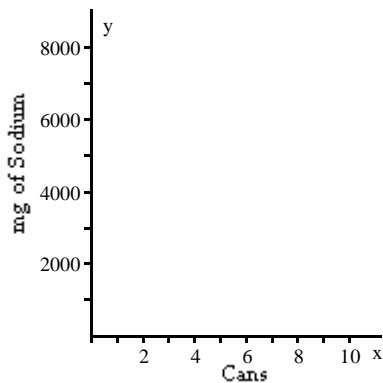

- 1 allowance = 3 cans;
- 2 allowances = 5 cans;
- 3 allowances = 8 cans

B)

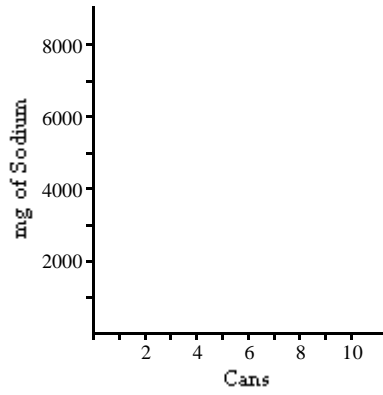

- 1 allowance = 3 cans;
- 2 allowances = 6 cans;
- 3 allowances = 9 cans

C)

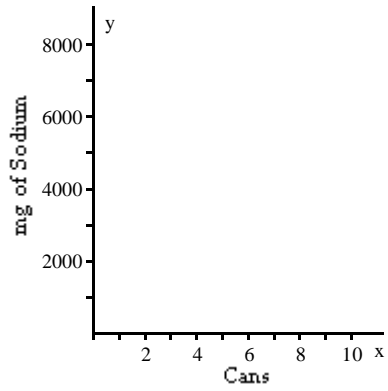

- 1 allowance = 6 cans;
- 2 allowances = 9 cans;
- 3 allowances = 3 cans

D)

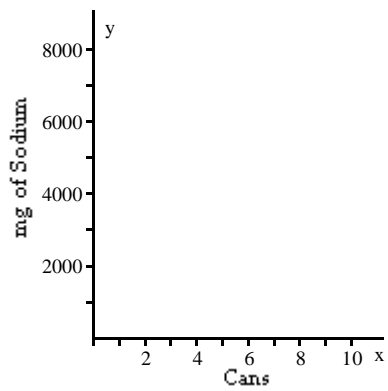

- 1 allowance = 3 cans;
- 2 allowances = 6 cans;
- 3 allowances = 9 cans

Answer: B

130) In order to receive a B in a course, it is necessary to get an average of 80% correct on two one-hour exams of 100 points each, on one midterm exam of 200 points, and on one final exam of 500 points. If a student scores 91, and 84 on the one-hour exams, and 141 on the midterm exam, what is the minimum score on the final exam that the person can get and still earn a B?

- A) 584
- B) 314
- C) 449
- D) 404

Answer: D

131) A store is discounting all regularly priced items by 50%. (i) Find a function f that computes the sale price of an item having a regular price of x . (ii) If an item normally costs \$153.93, what is its sale price?

- A) $f(x) = x - 0.5x$; \$76.97
- B) $f(x) = x - 50$; \$103.93
- C) $f(x) = 0.5x$; \$76.97
- D) $f(x) = x - 0.5$; \$153.43

Answer: A

132) A store is discounting all regularly priced items by 30%. (i) Find a function f that computes the sale price of an item having a regular price of x . (ii) Find the regular price of an item that costs \$78.46 on sale.

- A) $f(x) = 0.3x$; \$261.53
- B) $f(x) = x - 0.3x$; \$112.09
- C) $f(x) = 0.3 + x$; \$78.16
- D) $f(x) = x - 0.3$; \$78.76

Answer: B

Solve the problem. Round your answer to the nearest whole number.

133) A tree casts a shadow 21 m long. At the same time, the shadow cast by a 70-cm tall statue is 73 cm long. Find the height of the tree.

- A) 19 m
- B) 21 m
- C) 20 m
- D) 22 m

Answer: C

134) A line from the top of a cliff to the ground passes just over the top of a pole 7.0 feet high and meets the ground at a point 6.0 feet from the base of the pole. If the point is 64 feet from the base of the cliff, how high is the cliff?

- A) 6 feet
- B) 2688 feet
- C) 448 feet
- D) 75 feet

Answer: D

Solve the problem.

135) Martha can rake the leaves in her yard in 7 hours. Her brother can do the job in 4 hours. How long will it take them to do the job working together?

A) $\frac{1}{28}$ hr

B) $\frac{28}{11}$ hr

C) $\frac{1}{11}$ hr

D) $\frac{28}{3}$ hr

Answer: B

136) One maid can clean the house in 3 hours. Another maid can do the job in 8 hours. How long will it take them to do the job working together?

A) $\frac{24}{11}$ hr

B) $\frac{24}{5}$ hr

C) $\frac{1}{24}$ hr

D) $\frac{1}{11}$ hr

Answer: A

137) Frank can type a report in 6 hours. James takes 4 hours to type it. How long will it take the two of them typing together?

A) $\frac{1}{24}$ hr

B) $\frac{1}{10}$ hr

C) 12 hr

D) $\frac{12}{5}$ hr

Answer: D

138) An experienced accountant can prepare a tax return in 18 hours. A novice accountant can do the job in 24 hours.

How long will it take them to do the job working together?

A) $\frac{1}{432}$ hr

B) $\frac{72}{7}$ hr

C) $\frac{1}{42}$ hr

D) 72 hr

Answer: B

- 139) A water tank can be filled in 9 minutes and emptied in 10 minutes. If the drain is accidentally left open when the tank is being filled, how long does it take to fill the tank?
- A) 90 min
 - B) $\frac{1}{90}$ min
 - C) $\frac{90}{19}$ min
 - D) $\frac{1}{19}$ min

Answer: A

- 140) How many liters of a 10% alcohol solution must be mixed with 40 liters of a 50% solution to get a 20% solution?
- A) 160 liters
 - B) 120 liters
 - C) 12 liters
 - D) 16 liters

Answer: B

- 141) In a chemistry class, 5 liters of a 4% silver iodide solution must be mixed with a 10% solution to get a 6% solution. How many liters of the 10% solution are needed?
- A) 5 liters
 - B) 1.5 liters
 - C) 2.5 liters
 - D) 3.5 liters

Answer: C

- 142) Find the length of a rectangular lot with a perimeter of 90 m if the length is 7 m more than the width.
- A) 26 m
 - B) 52 m
 - C) 45 m
 - D) 19 m

Answer: A

- 143) A square plywood platform has a perimeter which is 6 times the length of a side, decreased by 6. Find the length of a side.
- A) 1
 - B) 5
 - C) 3
 - D) 2

Answer: C

- 144) A rectangular Persian carpet has a perimeter of 192 inches. The length of the carpet is 18 in. more than the width. What are the dimensions of the carpet?
- A) Width: 39 in.; length: 57 in.
 - B) Width: 87 in.; length: 105 in.
 - C) Width: 57 in.; length: 75 in.
 - D) Width: 78 in.; length: 96 in.

Answer: A

Write the following in interval notation.

145) $\{x \mid x > 7\}$

- A) $(\infty, 7)$
- B) $(7, \infty)$
- C) $(-\infty, 7)$
- D) $(7, -\infty)$

Answer: B

146) $\{x \mid x \leq -7\}$

- A) $(\infty, -7]$
- B) $[-7, \infty)$
- C) $(-\infty, -7]$
- D) $[-7, -\infty)$

Answer: C

147) $\{x \mid -5 < x < 6\}$

- A) $(-5, 6]$
- B) $(-5, 6)$
- C) $[-5, 6]$
- D) $[-5, 6)$

Answer: B

148) $\{x \mid -6 \leq x \leq 4\}$

- A) $[-6, 4)$
- B) $(-6, 4]$
- C) $[-6, 4]$
- D) $(-6, 4)$

Answer: C

149) $\{x \mid -7 \leq x < 5\}$

- A) $[-7, 5]$
- B) $(-7, 5]$
- C) $[-7, 5)$
- D) $(-7, 5)$

Answer: C

150) $\{x \mid -4 < x \leq 1\}$

- A) $(-4, 1]$
- B) $[-4, 1)$
- C) $(-4, 1)$
- D) $[-4, 1]$

Answer: A

- 151) $\{x \mid -5 < x < -2\}$ A) $[-5, -2]$
B) $[-5, -2)$
C) $(-5, -2)$
D) $(-5, -2]$

Answer: C

Solve the inequality symbolically. Express the solution set in interval notation.

152) $10a - 1 > 9a - 3$

A) $(-\infty, -2)$

B) $(-4, \infty)$

C) $(-\infty, -$

4) D) $(-2, \infty)$

Answer: D

153) $12z - 9 \leq 11z - 11$

A) $(-\infty, -2]$

B) $(-\infty,$

12) C) $(12, \infty)$

D) $[-2, \infty)$

Answer: A

154) $-11x + 6 \geq -12x + 4$

A) $[-2, \infty)$

B) $(-11, \infty)$

C) $(-\infty, -11)$

D) $(-\infty, -2]$

Answer: A

155) $-10 + 10y + 10 \geq 9y - 3$

A) $(-\infty, -$

3] B) $(10, \infty)$

C) $(-\infty,$

10) D) $[-3, \infty)$

Answer: D

156) $25y + 40 > 5(4y -$

1) A) $(25, \infty)$

B) $(-\infty, 25)$

C) $(-\infty, -9)$

D) $(-9, \infty)$

Answer: D

157) $-6(2z + 4) < -18z - 12$

A) $(-18, \infty)$

B) $(-\infty, -$

18) C) $(2, \infty)$

D) $(-\infty,$
2) Answer:
D

158) $\frac{3x-8}{5} < \frac{23}{3}$

A) $(\frac{23}{3}, \infty)$

B) $(-\infty, \frac{139}{9})$

C) $(-\infty, \frac{23}{3})$

D) $(\frac{139}{9}, \infty)$

Answer: B

159) $\frac{2x-5}{-2} < \frac{1}{2}$

A) $(4, \infty)$

B) $(-\infty, \frac{1}{2})$

C) $(2, \infty)$

D) $(\frac{1}{4}, \infty)$

Answer: C

160) $-8 < 6x + 4 \leq 6$

A) $(\frac{1}{3}, -2]$

B) $(-2, \frac{1}{3}]$

C) $[\frac{1}{3}, -2)$

D) $[-2, \frac{1}{3})$

Answer: B

161) $-1 \leq 9 - 6x \leq 17$

A) $(\frac{5}{3}, -\frac{4}{3})$

B) $[\frac{5}{3}, -\frac{4}{3}]$

C) $[-\frac{4}{3}, \frac{5}{3}]$

D) $(-\frac{4}{3}, \frac{5}{3})$

Answer: C

Solve the inequality graphically. Express the solution in set-builder notation.

162) $-9x - 3 \leq -10x + 5$

- A) $\{x|x \geq 8\}$
- B) $\{x|x \leq 8\}$
- C) $\{x|x > -9\}$
- D) $\{x|x < -9\}$

Answer: B

163) $-7x + 11 \geq -8x + 12$

- A) $\{x|x \leq 1\}$
- B) $\{x|x < -7\}$
- C) $\{x|x > -7\}$
- D) $\{x|x \geq 1\}$

Answer: D

164) $12x - 12 > 3(3x - 10)$

- A) $\{x|x > 12\}$
- B) $\{x|x > -6\}$
- C) $\{x|x < 12\}$
- D) $\{x|x < -6\}$

Answer: B

165) $-4(6x + 4) < -28x - 32$

- A) $\{x|x < -4\}$
- B) $\{x|x > -28\}$
- C) $\{x|x < -28\}$
- D) $\{x|x > -4\}$

Answer: A

166) $\frac{9x+4}{7} < \frac{59}{9}$

- A) $\{x|x > \frac{59}{9}\}$
- B) $\{x|x > \frac{377}{81}\}$
- C) $\{x|x < \frac{59}{9}\}$
- D) $\{x|x < \frac{377}{81}\}$

Answer: D

167) $\frac{2x-4}{-6} < -4$

- A) $\{x|x > -2\}$
- B) $\{x|x > 14\}$
- C) $\{x|x > 28\}$
- D) $\{x|x < -4\}$

Answer: B

Use the given graph of $y = ax + b$ to solve the inequality. Write the solution set in interval notation.

168) $5x - 8.8 > 0$

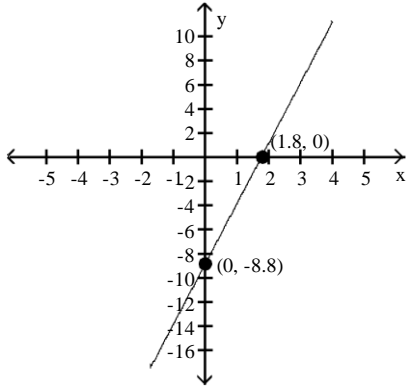

$y = 5x - 8.8$

A) $(1.8, \infty)$

B) $(-\infty, 1.8]$

C) $(-\infty, 1.8)$

D) $[1.8, \infty)$

Answer: A

169) $4x - 3 \geq 2x + 1$

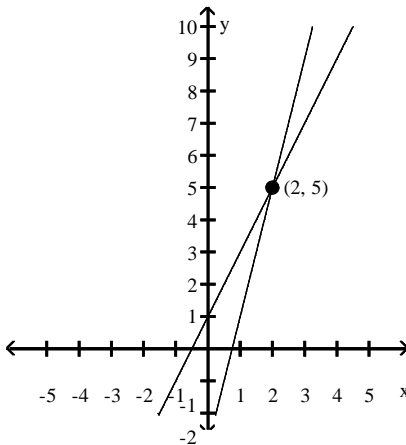

$y = 2x + 1$

$y = 4x - 3$

A) $(-\infty,$

2] B) $[2,$

$\infty)$

C) $(-\infty, 2)$

D) $(2, \infty)$

Answer: B

Solve the inequality using the x-intercept method or the intersection-of-graphs method. Express the solution set in interval notation.

170) $9z - 6 > 8z - 1$

A) $(-7, \infty)$

B) $(5, \infty)$

C) $(-\infty, -$

7) D) $(-\infty,$

5)

Answer: B

171) $6z - 11 \leq 5z - 14$

- A) $[-3, \infty)$
- B) $(-\infty, 6)$
- C) $(-\infty, -3]$
- D) $(6, \infty)$

Answer: C

172) $8y - 5 \geq 7y - 13$

- A) $(-\infty, 8)$
- B) $[-8, \infty)$
- C) $(-\infty, -8]$
- D) $(8, \infty)$

Answer: B

173) $-1 + 6y + 1 \geq 5y - 4$

- A) $(-\infty, -4]$
- B) $(-\infty, 6)$
- C) $[-4, \infty)$
- D) $(6, \infty)$

Answer: C

174) $20z + 20 > 5(3z + 2)$

- A) $(-\infty, -2)$
- B) $(20, \infty)$
- C) $(-2, \infty)$
- D) $(-\infty, 20)$

Answer: C

175) $-3(3z + 16) < -12z - 27$

- A) $(-12, \infty)$
- B) $(-\infty, -12)$
- C) $(7, \infty)$
- D) $(-\infty, 7)$

7) Answer:

D

Solve the compound linear inequality graphically. Write your answer in interval notation.

176) $15 < -5b \leq 35$

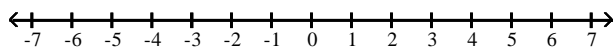

- A) $(3, 7]$
- B) $(-7, -3)$
- C) $[-7, -3]$
- D) $[-7, -3)$

Answer: D

177) $-19 < 4y + 5 \leq -3$

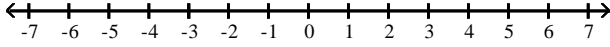

- A) $[-6, -2]$
- B) $(-6, -2]$
- C) $(-6, -2)$
- D) $[-6, -2)$

Answer: B

178) $-5 < -2z + 3 \leq 3$

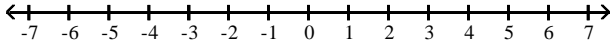

- A) $[-4, 0)$
- B) $(0, 4]$
- C) $[0, 4)$
- D) $(-4, 0]$

Answer: C

179) $4 < \frac{10x-3}{13} < 9$

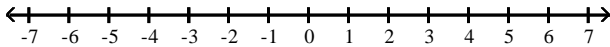

- A) $\left(\frac{11}{2}, 12\right)$
- B) $\left(-12, \frac{11}{2}\right)$
- C) $\left(-\frac{11}{2}, 12\right)$
- D) $\left(-\infty, \frac{11}{2}\right) \cup (12, \infty)$

Answer: A

180) $-2 < \frac{10-4x}{3} \leq 9$

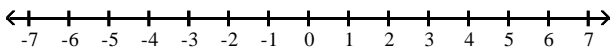

- A) $\left[-\frac{17}{4}, -4\right]$
- B) $\left[-\frac{17}{4}, 4\right)$
- C) $\left[\frac{17}{4}, 4\right)$
- D) $\left(-\infty, -\frac{17}{4}\right) \cup [4, \infty)$

Answer: B

181) $-5 < 3x + 4 \leq 7$

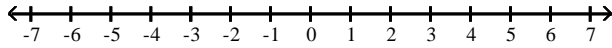

- A) $(-3, 1]$
- B) $[-3, 1]$
- C) $[-3, 1)$
- D) $(-3, 1)$

Answer: A

Solve the inequality numerically. Approximate endpoints to the nearest tenth.

182) $(\sqrt{7} - \pi)x - 5.1 < 0$

- A) $x > 10.7$
- B) $x > -10.3$
- C) $x < -10.3$
- D) $x < 10.7$

Answer: B

183) $2.3(x - 1.1) + 1.7x \geq 9$

- A) $x \leq -2.9$
- B) $x \geq -3.1$
- C) $x \geq 2.9$
- D) $x \geq 3.1$

Answer: C

Solve the problem.

- 184) The function f computes the annual interest paid on savings of x dollars with an interest rate of 9%. The graph of f and the horizontal line $y = 3.78$ are shown in the figure. Determine the savings amounts that result in (i) an annual interest less than \$3.78 and (ii) an annual interest of \$3.78 or more.

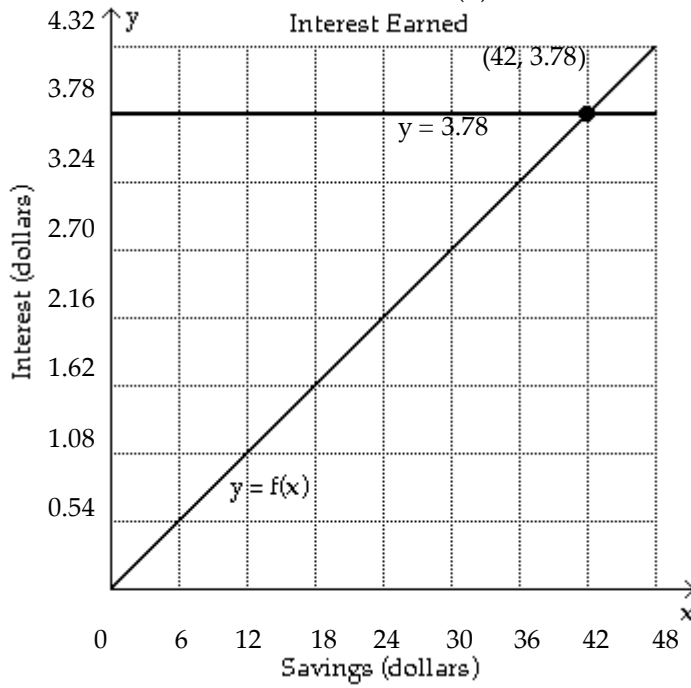

- A) between \$6 and \$42; \$42 or more
- B) between \$0 and \$42; \$42 or more
- C) \$42 or more; \$42
- D) \$42 or less; between \$42 and \$48

Answer: B

185) The function f computes the annual interest paid on savings of x dollars with an interest rate of 8%. The graph of f and the horizontal line $y = 3.36$ are shown in the figure. Determine the x -values that satisfy (i) the equation $f(x) = 3.36$ and (ii) the equation $f(x) > 3.36$. Express your answers symbolically.

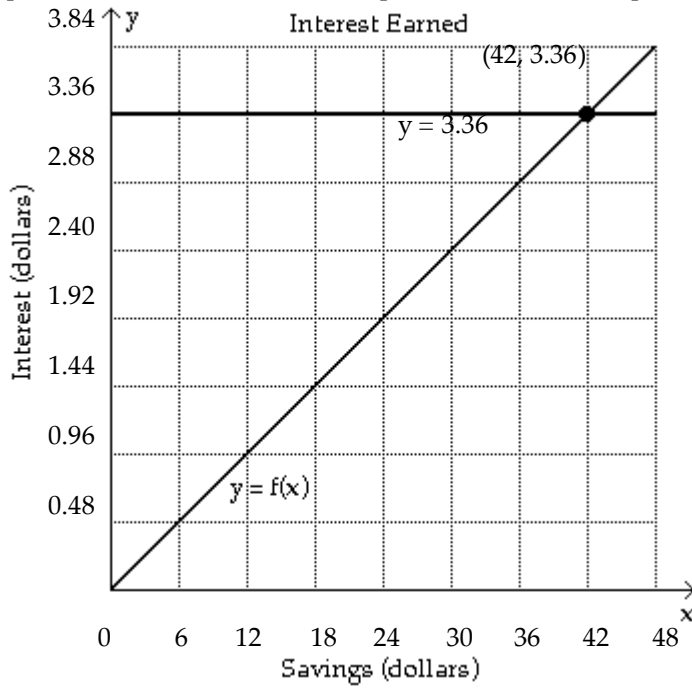

- A) $\{x \mid x < 42\}; \{x \mid x > 42\}$
- B) $\{x \mid x = 42\}; \{x \mid x > 42\}$
- C) $\{x \mid x < 42\}; \{x \mid x \geq 42\}$
- D) $\{x \mid x = 42\}; \{x \mid x \geq 42\}$

Answer: B

186) The function f models the population of Country X from 1991 to 1998. The graphs of f and the horizontal line $y = 230$ are shown in the figure. Use the graphs to determine when there was (i) a population equal to 230 million and (ii) a population of 230 million or less.

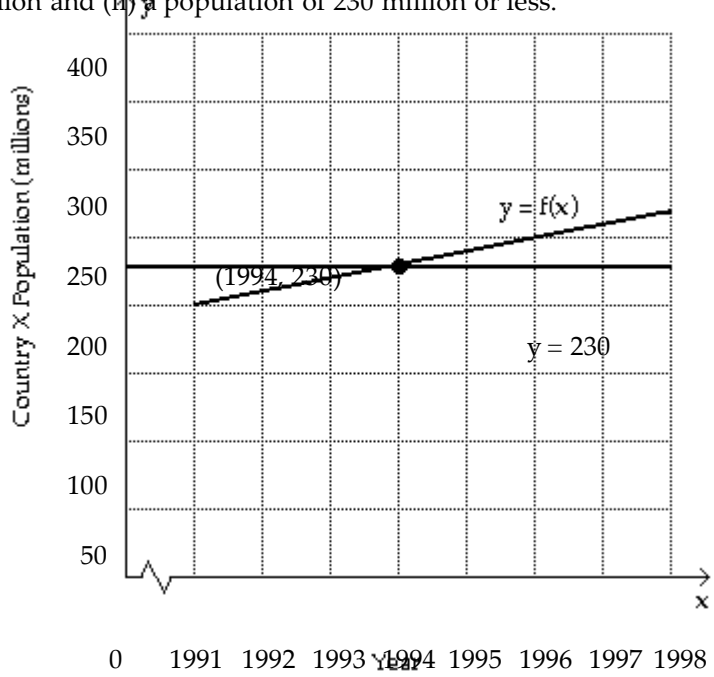

- A) between 1994 and 1998; earlier than 1994
- B) 1995; between 1991 and 1995
- C) 1994; between 1991 and 1994
- D) 1994; after 1994

Answer: C

187) The function f models the population of Country X from 1991 to 1998. The graphs of f and the horizontal line $y = 115$ are shown in the figure. Use the graphs to determine the x -values that satisfy (i) the inequality $f(x) > 115$ and (ii) $f(x) \geq 115$. Express your answers symbolically.

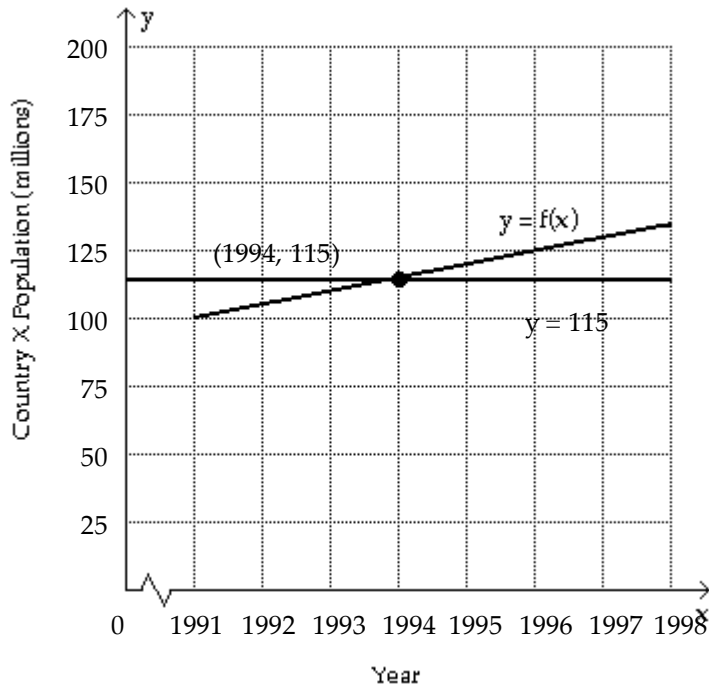

- A) $\{x \mid x \geq 1994\}; \{x \mid x > 1994\}$
- B) $\{x \mid x = 1994\}; \{x \mid x > 1994\}$
- C) $\{x \mid x > 1994\}; \{x \mid x \geq 1994\}$
- D) $\{x \mid x = 1994\}; \{x \mid x \geq 1994\}$

Answer: C

188) Trains S and T are both traveling in the same direction. Their distances in miles North of Dallas after x hours are computed by the functions f_S and f_T , respectively, and their graphs are shown in the figure for $0 \leq x \leq 8$. (i) Which train is traveling slower? (ii) How many hours elapse before the two trains are the same distance from Dallas and how far are they from Dallas when this occurs?

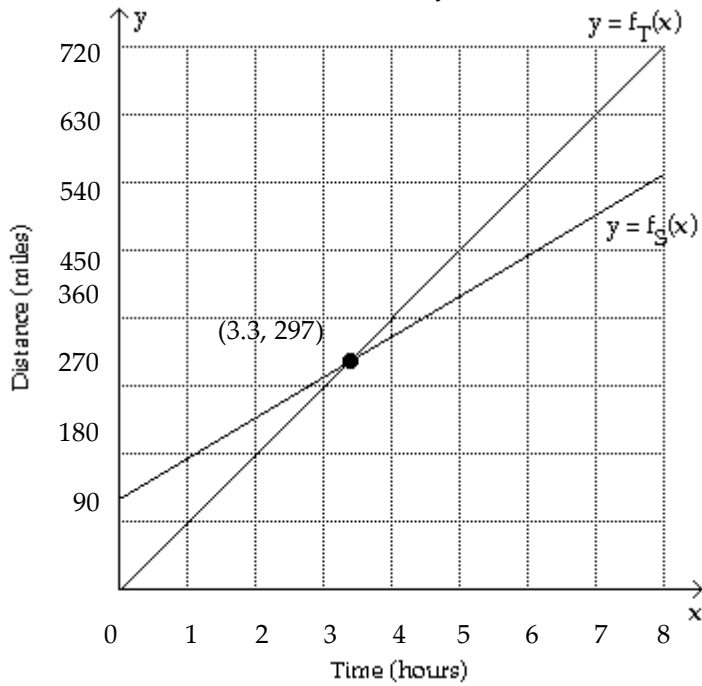

- A) train S; 297 hours, 3.3 miles
- B) train S; 3.3 hours, 297 miles
- C) train T; 3.3 hours, 297 miles
- D) train T; 297 hours, 3.3 miles

Answer: B

189) Trains S and T are both traveling in the same direction. Their distance in miles North of Denver after x hours are computed by the functions f_S and f_T , respectively, and their graphs are shown in the figure for $0 \leq x \leq 8$. During what time interval is Train T closer to Denver than Train S?

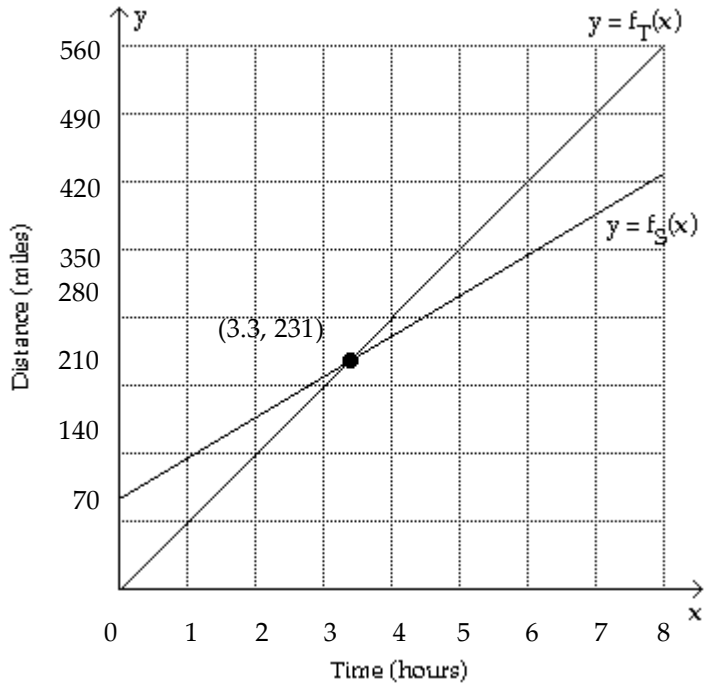

- A) after 3.3 hours, or $x > 3.3$
- B) always, or $x \geq 0$
- C) between 0 and 3.3 hours, or $0 \leq x < 3.3$
- D) between 3.3 and 8 hours, or $3.3 < x \leq 8$

Answer: C

190) The linear function f computes the distance y in miles between a car and the city of Ottawa after x hours, where

$0 \leq x \leq 8$. The graphs of f and the horizontal lines $y = 75$ and $y = 150$ are shown in the figure. (i) Is the car moving toward or away from Ottawa? (ii) Determine the times when the car is 75 miles and 150 miles from Ottawa.

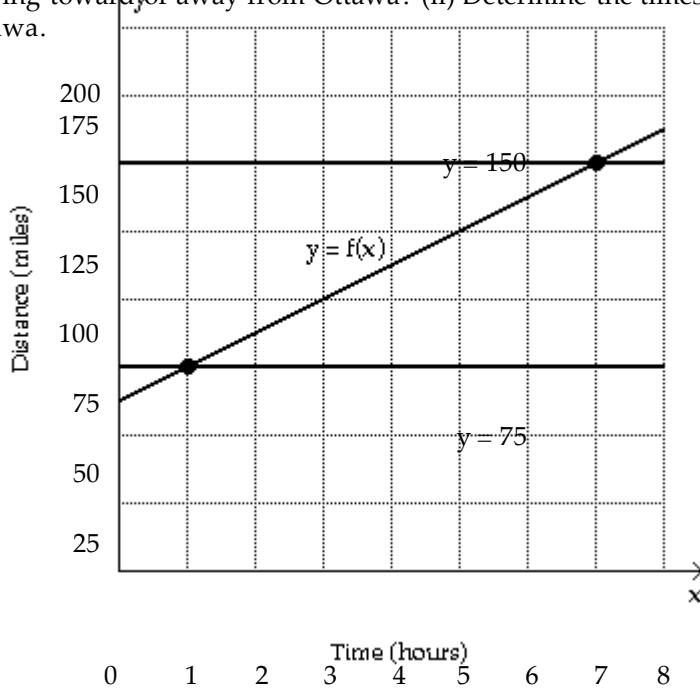

- A) away from Ottawa.; The car is 75 miles from Ottawa after 3 hours and 150 miles after 6 hours.
- B) away from Ottawa.; The car is 75 miles from Ottawa after 1 hour and 150 miles after 7 hours.
- C) toward from Ottawa.; The car is 75 miles from Ottawa after 7 hours and 150 miles after 1 hour.
- D) away from Ottawa.; The car is 75 miles from Ottawa after 2 hours and 150 miles after 7 hours.

Answer: B

- 191) The linear function f computes the distance y in miles between a car and the city of Vancouver after x hours, where $0 \leq x \leq 8$. The graphs of f and the horizontal lines $y = 90$ and $y = 180$ are shown in the figure. (i) When is the car 90 to 180 miles from Vancouver? (ii) when is the car's distance from Vancouver less than 180 miles?

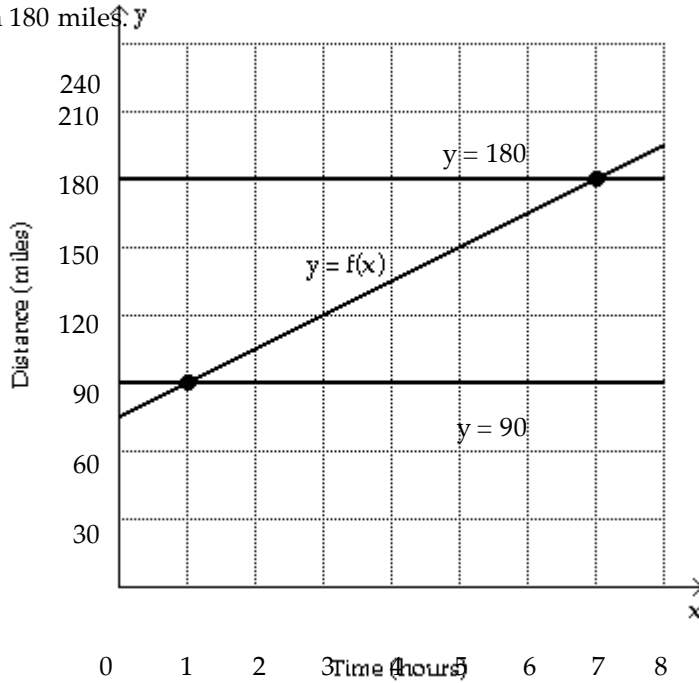

- A) before it has traveled 7 hours; between 7 and 8 hours after departure
 B) after it has traveled 1 hour; before it has traveled 7 hours
 C) between 1 and 7 hours after departure; before it has traveled 7 hours
 D) between 3 and 8 hours after departure; after it has traveled 1 hour

Answer: C

- 192) The total area in acres of farmland owned by governmental bodies in Country X can be modeled by $A(x) = 20.8(x - 1950) - 193$, where x is the the year and $x \leq 1995$. Find the x -intercept of the graph of A symbolically. Round to the nearest year.

- A) 1956
 B) 1963
 C) 1961
 D) 1959

Answer: D

- 193) Ozone levels inside a building should not exceed 50 parts per billion (ppb). In a scientific study, an air filter was able to remove 44% of the ozone entering a building. Approximate the range of ozone concentrations in outside air that this filter will reduce to an acceptable level.

- A) $x \geq 89$ ppb
 B) $71 \text{ ppb} \leq x \leq 89$ ppb
 C) $x \leq 107$ ppb
 D) $x \leq 89$ ppb

Answer: D

194) A certain electronic air cleaner is capable of filtering x liters of air per second and the percentage of the contaminants that are removed from the air may be calculated by $f(x) = 1.94x + 7.19$ where $20 \leq x \leq 95$. (i) Graph f in $[0, 85, 5]$ by $[0, 200, 5]$. (ii) Use the intersection-of-graphs method to estimate the x -values where 75% to 90% of the pollutants are removed.

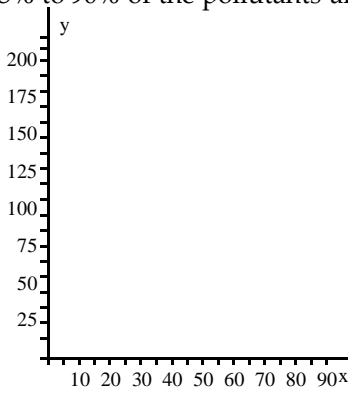

A)

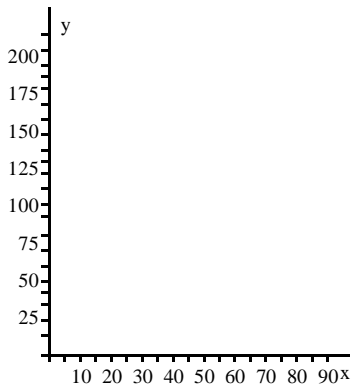

75% to 90% are removed when about 26 to 31 liters of air are filtered.

B)

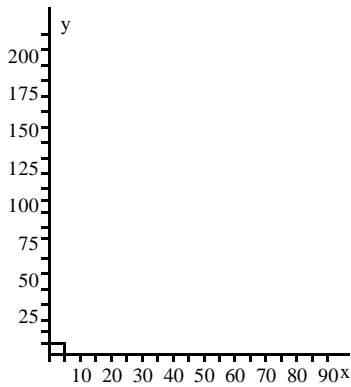

75% to 90% are removed when about 25 to 30 liters of air are filtered.

C)

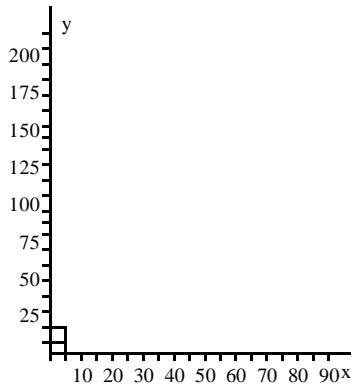

75% to 90% are removed when about 35 to 43 liters of air are filtered.

D)

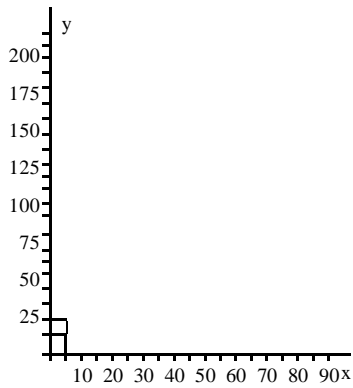

75% to 90% are removed when about 42 to 50 liters of air are filtered.

Answer: C

195) The following data is exactly linear. Find a linear function that models the data, and use the function to solve the inequality $f(x) > \frac{3}{2}$.

x	0	2	4	6
y	-3.5	0.5	4.5	8.5

A) $x > -\frac{11}{4}$

B) $x > \frac{13}{4}$

C) $x < 2$

D) $x > \frac{5}{2}$

Answer: D

196) The following data is exactly linear. Find a linear function that models the data, and use the function to solve the inequality $21 \leq f(x) < 29$.

x	0	2	4	6
y	5	9	13	17

- A) $10 \leq x < 14$
- B) $8 \leq x < 12$
- C) $-8 \leq x$
- D) $-12 \leq x < 8$

Answer: B

Write a formula for a linear function f that models the data exactly.

197)

x	-4	-2	0	2	4
f(x)	-3	1	5	9	13

- A) $f(x) = 2x + 5$
- B) $f(x) = -2x + 5$
- C) $f(x) = 4x + 13$
- D) $f(x) = -4x + 13$

Answer: A

198)

x	-4	-2	0	2	4
f(x)	22	12	2	-8	-18

- A) $f(x) = -10x - 18$
- B) $f(x) = 5x + 2$
- C) $f(x) = -5x + 2$
- D) $f(x) = 10x - 18$

Answer: C

Solve the problem.

199) To convert a temperature from degrees Celsius to degrees Fahrenheit, you multiply the temperature in degrees

Celsius by 1.8 and then add 32 to the result. Express F as a linear function of c .

- A) $F(c) = 33.8c$
- B) $F(c) = 1.8c + 32$
- C) $F(c) = 1.8 + 32c$
- D) $F(c) = \frac{c-32}{1.8}$

Answer: B

200) To convert a temperature from degrees Celsius to degrees Fahrenheit, you multiply the temperature in degrees Celsius by 1.8 and then add 32 to the result. Find F as a linear function of c , and use this function to convert 34°C to $^\circ\text{F}$.

- A) 88.5°F
- B) 93.2°F
- C) 80.9°F
- D) 84.2°F

Answer: B

- 201) If an object is dropped off of a tower, the velocity, V , of the object after t seconds can be obtained by multiplying t by 32 and adding 10 to the result. Express V as a linear function of t .
- A) $V(t) = 32t + 10$
 B) $V(t) = \frac{t-10}{32}$
 C) $V(t) = 32 + 10t$
 D) $V(t) = 42t$

Answer: A

- 202) If an object is dropped from a tower, then the velocity, V (in feet per second), of the object after t seconds can be obtained by multiplying t by 32 and adding 10 to the result. Find V as a linear function of t , and use this function to evaluate $V(4.4)$, the velocity of the object at time $t = 4.4$ seconds.

- A) $V(4.4) = 148.8$ feet per second
 B) $V(4.4) = 150.8$ feet per second
 C) $V(4.4) = 150.1$ feet per second
 D) $V(4.4) = 152.1$ feet per second

Answer: B

- 203) If an object is dropped from a tower of unknown height, the velocity of the object after t seconds can be obtained by multiplying t by 32 and adding 10 to the result. Therefore, you can express V as a linear function of t . Find the domain of this function.

- A) $(-1, \infty)$
 B) $[1, 4]$
 C) $[0, \infty)$
 D) $(-\infty,$

$\infty)$ Answer:

C

- 204) The cost for labor associated with fixing a washing machine is computed as follows: There is a fixed charge of \$25 for the repairman to come to the house, to which a charge of \$27 per hour is added. Find an equation that can be used to determine the labor cost, $C(x)$, of a repair that takes x hours.

- A) $C(x) = 25 + 27x$
 B) $C(x) = 25 - 27x$
 C) $C(x) = (25 + 27)x$
 D) $C(x) = 27 + 25x$

Answer: A

- 205) In a certain city, the cost of a taxi ride is computed as follows: There is a fixed charge of \$2.40 as soon as you get in the taxi, to which a charge of \$1.60 per mile is added. Find an equation that can be used to determine the cost, $C(x)$, of an x -mile taxi ride.

- A) $C(x) = 2.50x$
 B) $C(x) = 1.60 + 2.40x$
 C) $C(x) = 4.00x$
 D) $C(x) = 2.40 + 1.60x$

Answer: D

- 206) In a certain city, the cost of a taxi ride is computed as follows: There is a fixed charge of \$2.55 as soon as you get in the taxi, to which a charge of \$2.00 per mile is added. Find an equation that can be used to determine the cost, $C(x)$, of an x -mile taxi ride, and use this equation to find the cost of a 5-mile taxi ride.
- A) \$12.73
 - B) \$12.55
 - C) \$13.45
 - D) \$12.43

Answer: B

- 207) Marty's Tee Shirt & Jacket Company is to produce a new line of jackets with an embroidery of a Great Pyrenees dog on the front. There are fixed costs of \$660 to set up for production, and variable costs of \$41 per jacket. Write an equation that can be used to determine the total cost, $C(x)$, encountered by Marty's Company in producing x jackets.
- A) $C(x) = (660 + 41)x$
 - B) $C(x) = 660 + 41x$
 - C) $C(x) = 660x + 41$
 - D) $C(x) = 660 - 41x$

Answer: B

- 208) Marty's Tee Shirt & Jacket Company is to produce a new line of jackets with an embroidery of a Great Pyrenees dog on the front. There are fixed costs of \$660 to set up for production, and variable costs of \$28 per jacket. Write an equation that can be used to determine the total cost, $C(x)$, encountered by Marty's Company in producing x jackets, and use the equation to find the total cost of producing 109 jackets.
- A) \$3704
 - B) \$3692
 - C) \$3724
 - D) \$3712

Answer: D

209)

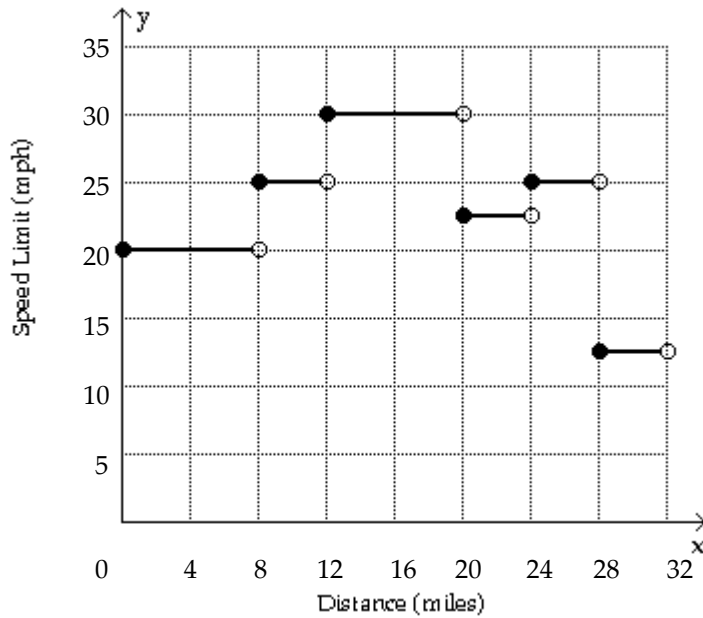

The graph of $y = f(x)$ gives the speed limit y along a rural highway after traveling x miles. (i) What are the maximum and minimum speed limits along this stretch of highway? (ii) Estimate the miles of highway with a speed limit of 25 miles per hour.

- A) Maximum 30 mph; minimum 17.5 mph; 8 miles
- B) Maximum 30 mph; minimum 12.5 mph; 8 miles
- C) Maximum 32.5 mph; minimum 12.5 mph; 9 miles
- D) Maximum 35 mph; minimum 10 mph; 6 miles

Answer: B

210)

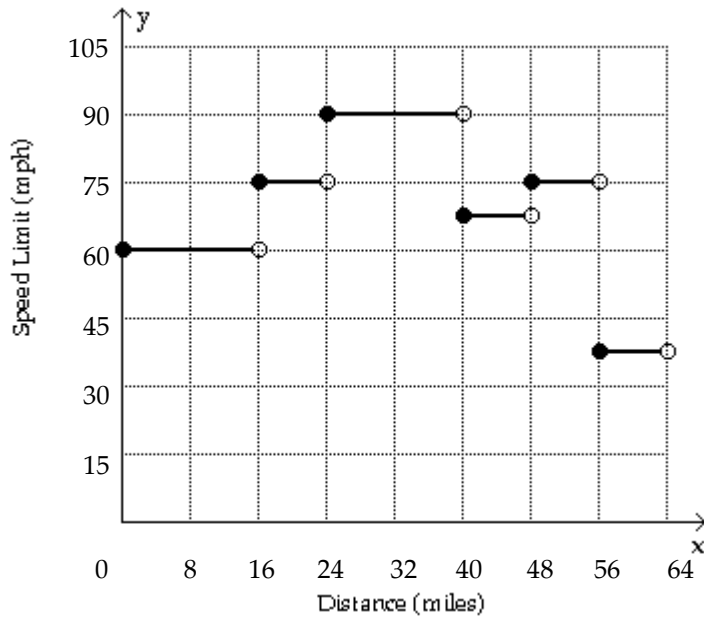

The graph of $y = f(x)$ gives the speed limit y along a rural highway after traveling x miles. (i) Evaluate $f(16)$, $f(44)$, and $f(48)$. (ii) At what x -values is the graph discontinuous?

- A) 67.5, 75, 90; $f(8)$, $f(16)$, $f(24)$, $f(40)$, and $f(48)$
- B) 60, 75, 75; $f(4)$, $f(16)$, $f(32)$, $f(40)$, and $f(48)$
- C) 75, 67.5, 75; $f(16)$, $f(24)$, $f(40)$, $f(48)$, and $f(56)$
- D) 60, 60, 75; $f(8)$, $f(16)$, $f(24)$, $f(48)$, and

$f(56)$ Answer: C

211)

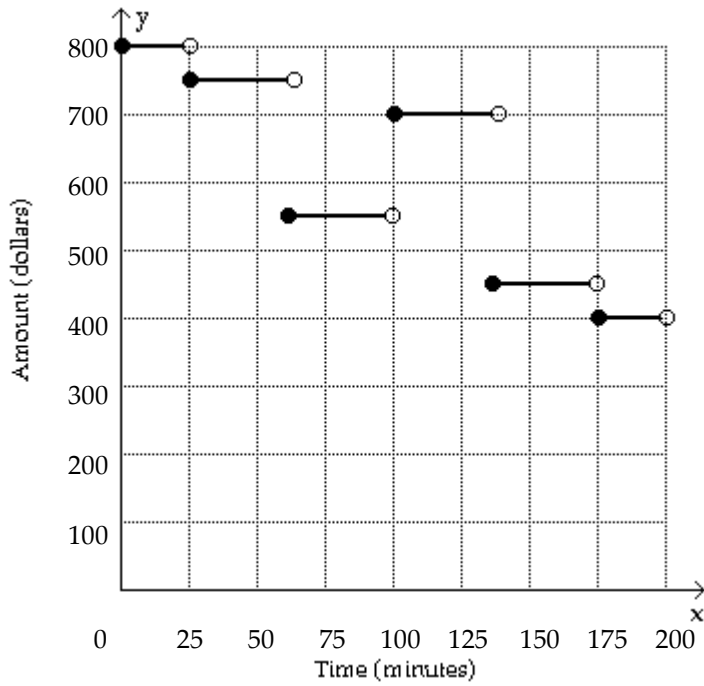

The graph of $y = f(x)$ depicts the amount of cash y in dollars that a bank teller has at his station after x minutes. (i) Determine the initial and final amounts of cash at the teller station. (ii) How many deposits occurred during this time period?

- A) \$800, \$400; 2
- B) \$800, \$300; 0
- C) \$800, \$400; 1
- D) \$700, \$450; 1

Answer: C

212)

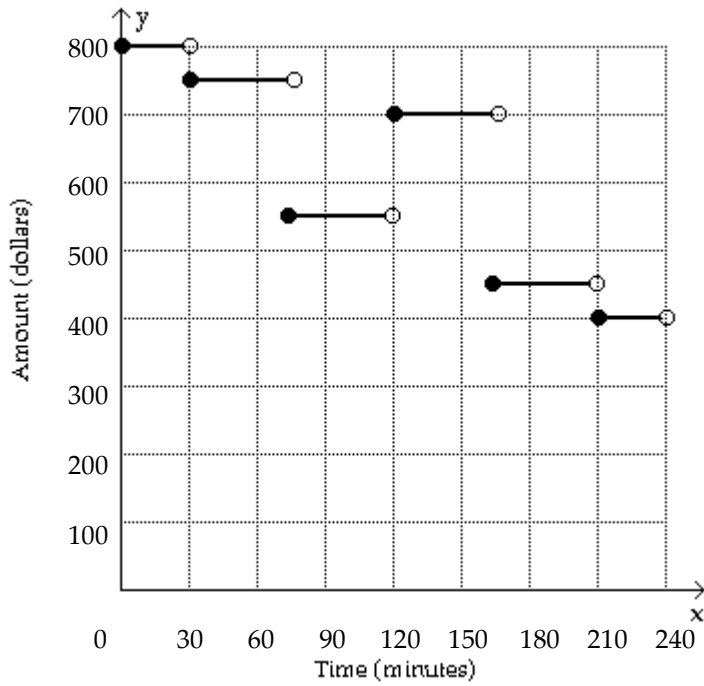

The graph of $y = f(x)$ depicts the amount of cash y in dollars that a bank teller has at his station after x minutes. (i) When did the largest withdrawal occur? (ii) How much was it?

- A) After 30 minutes; \$150
- B) After 165 minutes; \$150
- C) After 165 minutes; \$250
- D) After 75 minutes; \$250

Answer: C

213)

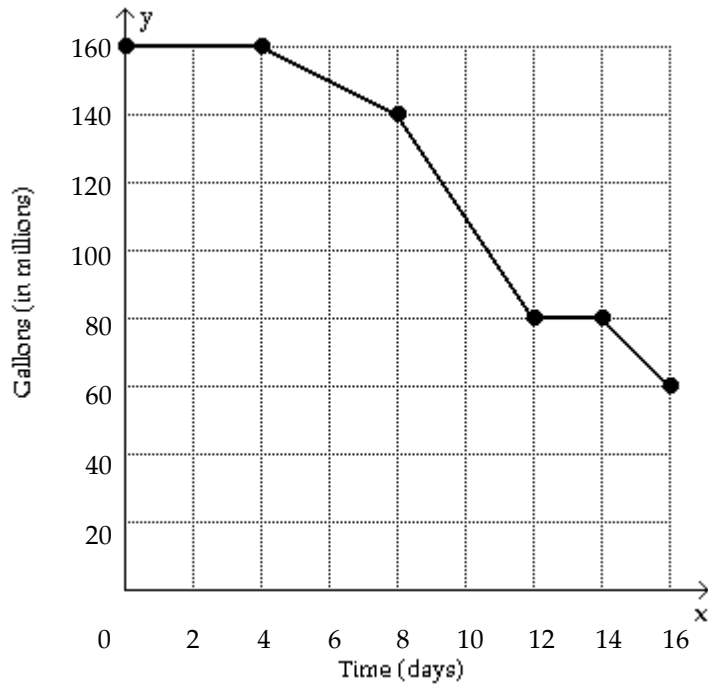

The graph of $y = f(x)$ represents the amount of oil in millions of gallons remaining in a tank after x days.

(i) Estimate the initial and final amounts of oil contained in the tank. (ii) When did the amount of oil in the tank remain constant?

- A) 140 million gallons, 40 million gallons; $8 \leq x \leq 16$
- B) 160 million gallons, 20 million gallons; $0 \leq x \leq 6$ or $8 \leq x \leq 14$
- C) 160 million gallons, 60 million gallons; $12 \leq x \leq 14$
- D) 160 million gallons, 60 million gallons; $0 \leq x \leq 4$ or $12 \leq x \leq 14$

Answer: D

214)

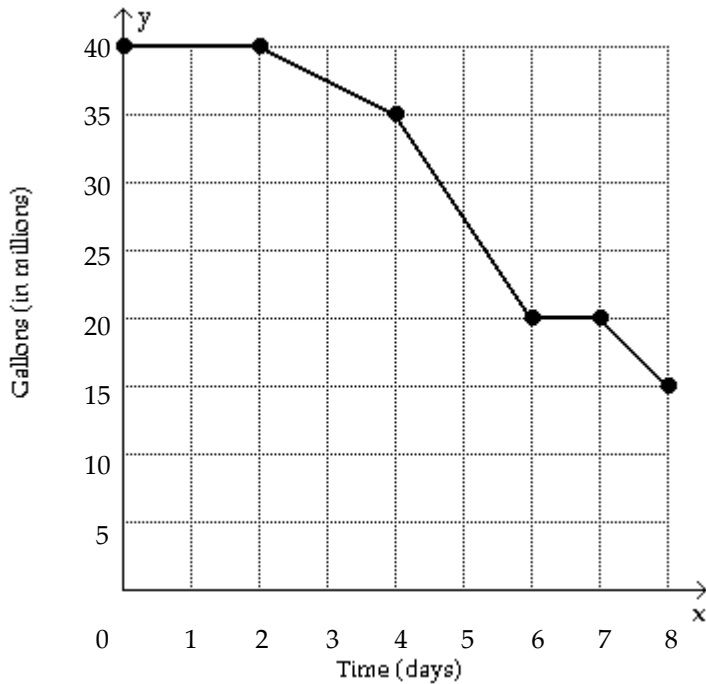

The graph of $y = f(x)$ represents the amount of oil in millions of gallons remaining in a tank after x days. (i) Approximate $f(3)$ and $f(5)$. (ii) At what rate was oil being drained from the tank when $4 \leq x \leq 6$?

- A) $f(3) \approx 32.5$, $f(5) \approx 25$; about 15 million gallons per day
- B) $f(3) \approx 42.5$, $f(5) \approx 17.5$; about 3.75 million gallons per day
- C) $f(3) \approx 37.5$, $f(5) \approx 27.5$; about 7.5 million gallons per day
- D) $f(3) \approx 35$, $f(5) \approx 27.5$; about 12.5 million gallons per day

Answer: C

215) The charges for renting a moving van are \$65 for the first 30 miles and \$8 for each additional mile. Assume that a fraction of a mile is rounded up. (i) Determine the cost of driving the van 99 miles. (ii) Find a symbolic representation for a function f that computes the cost of driving the van x miles, where $0 < x \leq 100$. (Hint: express f as a piecewise-constant function.)

- A) \$6987;

$$f(x) = \begin{cases} 65x & \text{if } 0 < x \leq 30 \\ 65x + 8(x - 30) & \text{if } 30 < x \leq 100 \end{cases}$$
- B) \$617;

$$f(x) = \begin{cases} 65 & \text{if } 0 < x \leq 30 \\ 65 + 8(x - 30) & \text{if } 30 < x \leq 100 \end{cases}$$
- C) \$1097;

$$f(x) = \begin{cases} 65 & \text{if } 0 < x \leq 30 \\ 65 + 8(x + 30) & \text{if } 30 < x \leq 100 \end{cases}$$

Answer: B

216) Sketch a graph showing the mileage that a person is from home after x hours if that individual drives at 27.5 mph to a lake 55 miles away, stays at the lake 1.5 hours, and then returns home at a speed of 55 mph.

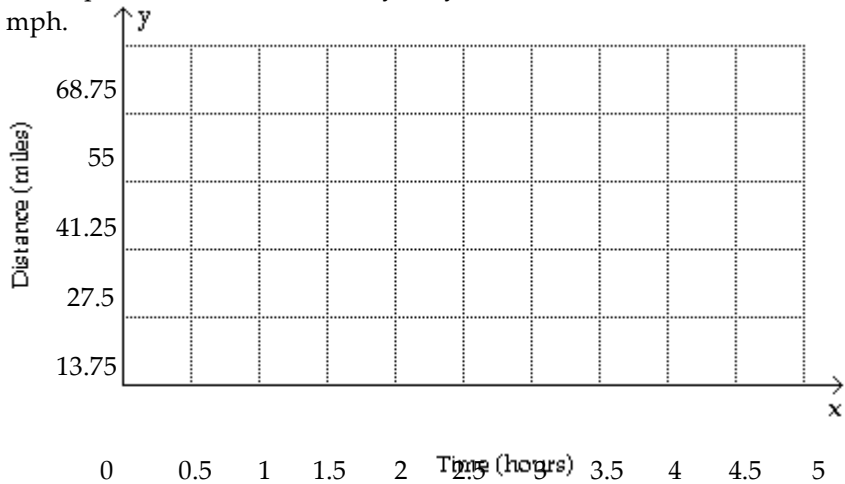

A)

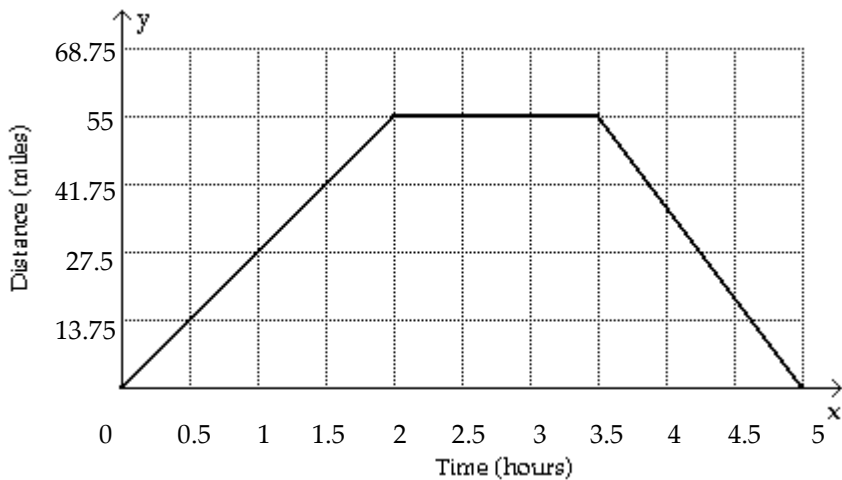

B)

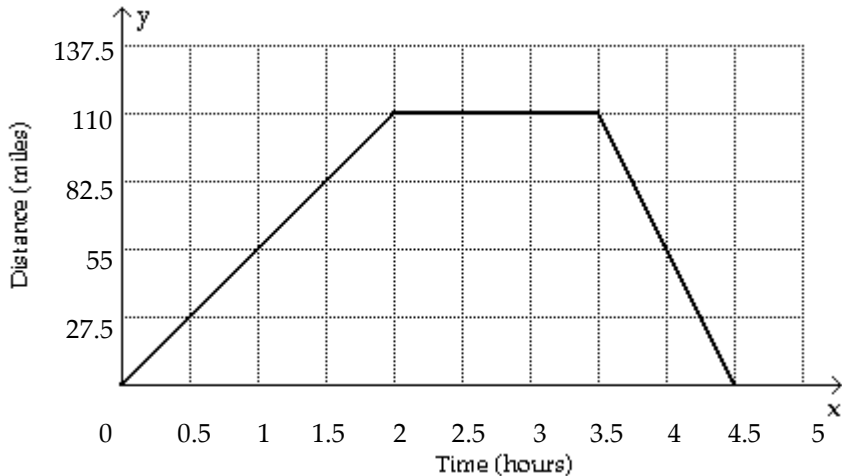

C)

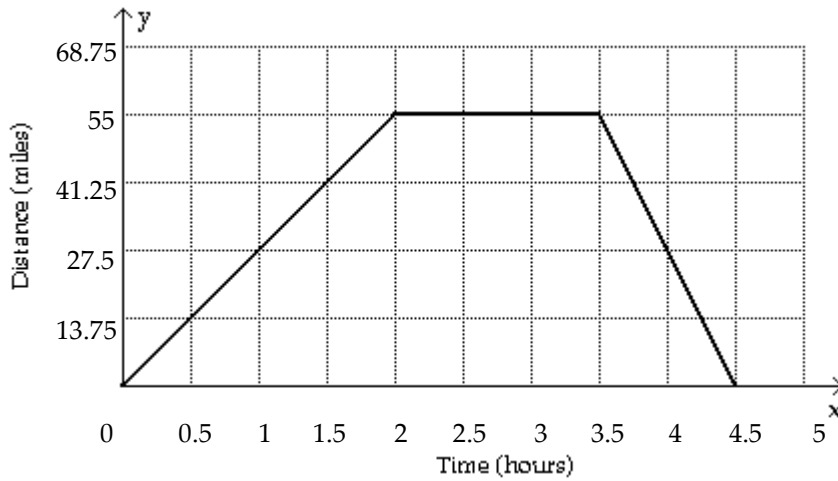

Answer: C

217) The table lists the average composite scores on a national entrance exam for selected years.

Year	1980	1982	1984	1986	1988	1990
Score	122.7	131.5	131.5	129.5	133.9	132.0

(i) Make a line graph of the data.

(ii) If the graph represents a piecewise-linear function f , find a symbolic representation for the piece of f located on the interval $[1982, 1984]$.

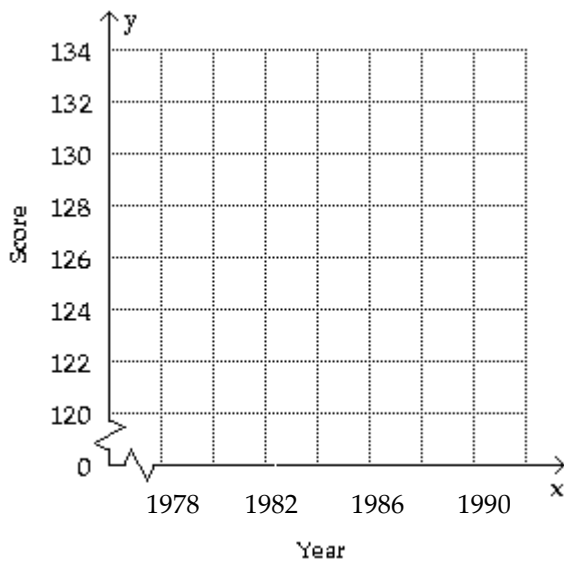

A)

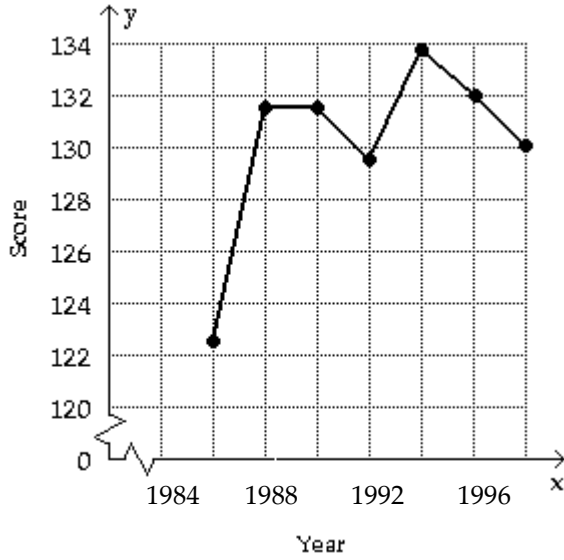

$$f(x) = 4.4x - 8598.1 \text{ if } 1986 \leq x \leq 1988$$

B)

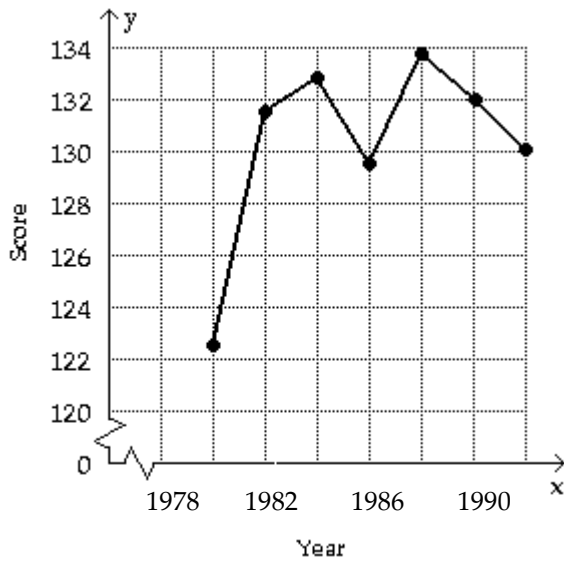

$$f(x) = 0.75x - 1356.5 \text{ if } 1982 \leq x \leq 1986$$

C)

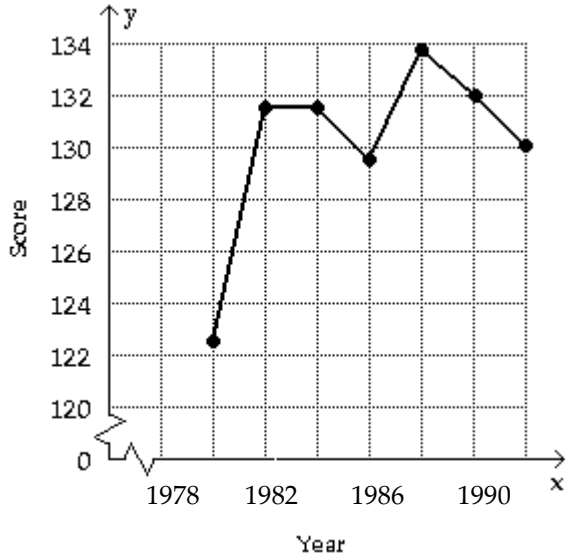

$$f(x) = 131.5 \text{ if } 1982 \leq x \leq 1984$$

D)

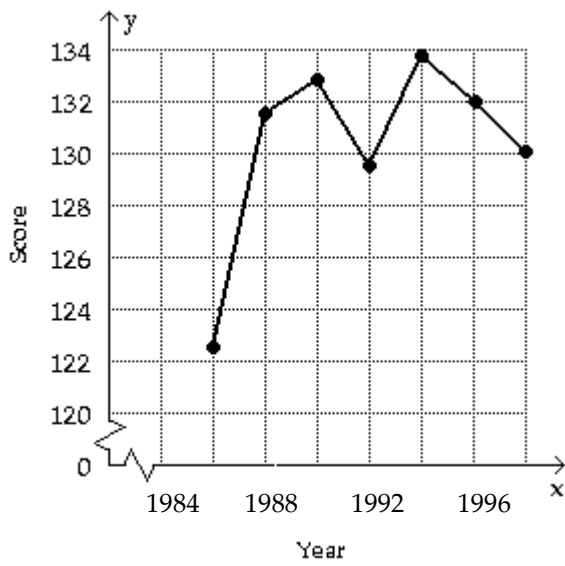

$$f(x) = 122.7 \text{ if } 1986 \leq x \leq 1988$$

Answer: C

218) The table lists the average composite scores on a national entrance exam for selected years.

Year	1982	1984	1986	1988	1990	1992
Score	122.7	131.5	131.5	129.5	133.9	132.0

Evaluate $f(1989)$.

- A) 130.5
- B) 130.9
- C) 131.7
- D) 131.5

Answer: C

219) In Country X, the average hourly wage in dollars from 1945 to 1995 can be modeled by

$$f(x) = \begin{cases} 0.071(x - 1945) + 0.36 & \text{if } 1945 \leq x < 1970 \\ 0.183(x - 1970) + 3.06 & \text{if } 1970 \leq x \leq 1995 \end{cases}$$

Use f to estimate the average hourly wages in 1950, 1970, and 1990.

- A) \$0.72, \$2.14, \$6.72
- B) \$3.42, \$0.36, \$6.72
- C) \$0.72, \$3.06, \$6.72

Answer: C

220) Sketch a graph that depicts the amount of water in a 50-gallon tank. The tank is initially full, and then a pump

is used to take water out of the tank at a rate of 6 gallons per minute. The pump is turned off after 5 minutes. At

that point, the pump is changed to one that will pump water into the tank. The change takes 2 minutes and the water level is unchanged during the switch. Then, water is pumped into the tank at a rate of 2 gallons per minute for 3 minutes.

A)

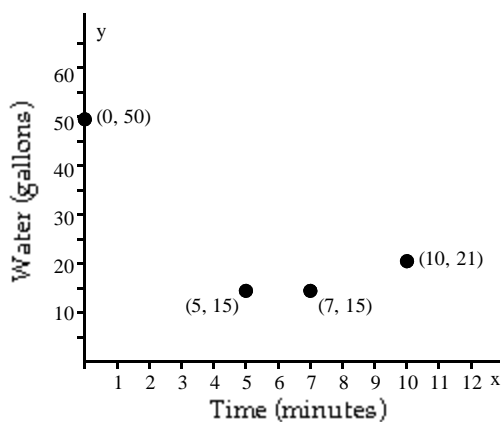

B)

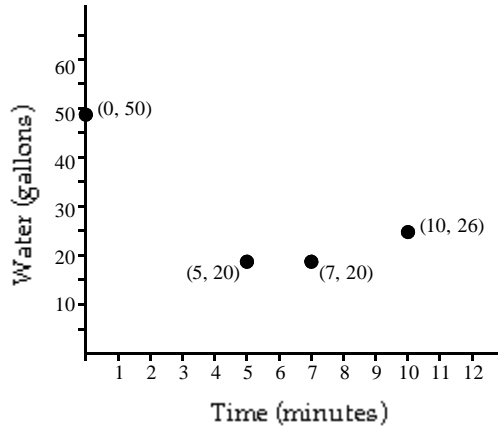

C)

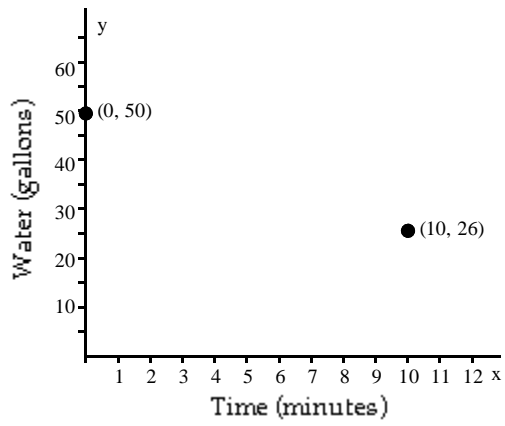

D)

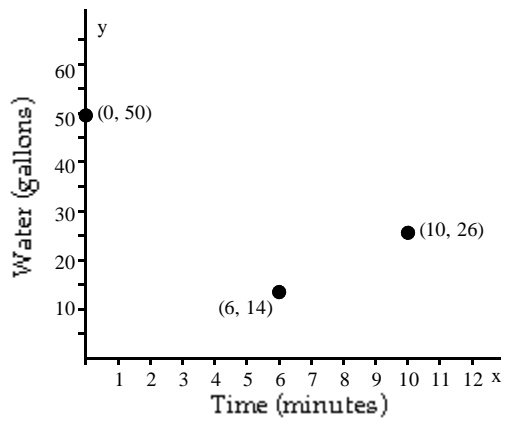

Answer: B

221) Sketch a graph that depicts the amount of water in a 50-gallon tank. The tank is initially full, And then a pump is used to take water out of the tank at a rate of 4 gallons per minute. This pump is turned off after 6 minutes and at that same time a different pump is turned on. This second pump puts water into the tank at a rate of 2 gallons per minute for 4 minutes.

A)

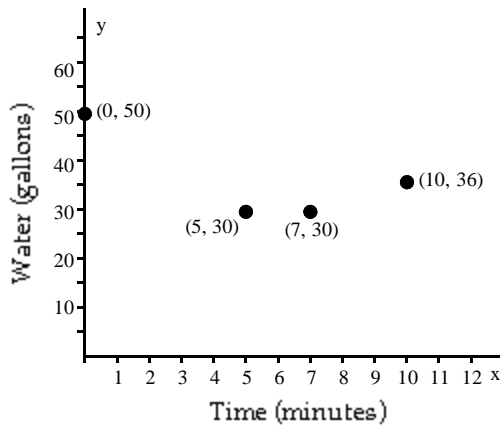

B)

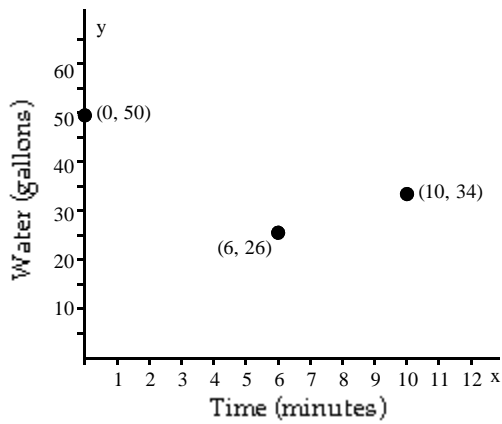

C)

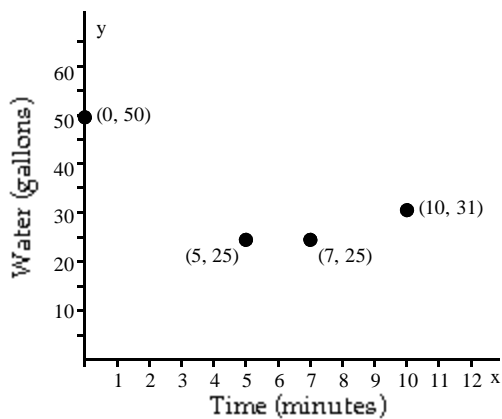

D)

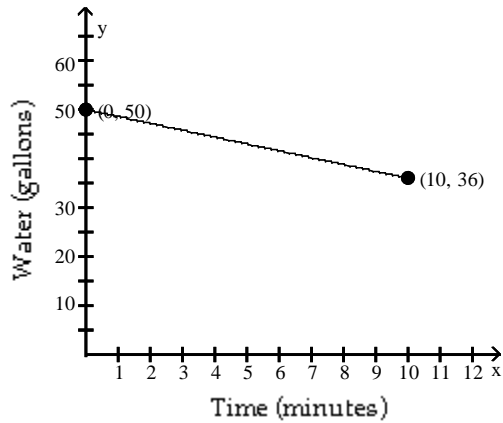

Answer: B

Evaluate the function f at the indicated value.

222)

$$f(-5) \text{ for } f(x) = \begin{cases} 7x, & \text{if } x \leq -1 \\ x - 5, & \text{if } x > -1 \end{cases}$$

A) 35

B) -10

C) -35

D) 0

Answer: C

223)

$$f(0) \text{ for } f(x) = \begin{cases} x - 7, & \text{if } x < 6 \\ 6 - x, & \text{if } x \geq 6 \end{cases}$$

A) 0

B) -1

C) -7

D) 6

Answer: C

224)

$$f(8) \text{ for } f(x) = \begin{cases} 7x + 3, & \text{if } x \leq 0 \\ 2 - 7x, & \text{if } 0 < x < 7 \\ 7x, & \text{if } x \geq 7 \end{cases}$$

A) 7

B) 59

C) -54

D) 8

Answer: D

225)

$$f(6) \text{ for } f(x) = \begin{cases} 8x + 1, & \text{if } x < 1 \\ 6x, & \text{if } 6 \leq x \leq 9 \\ 6 - 6x, & \text{if } x > 9 \end{cases}$$

- A) 55
- B) -30
- C) 36
- D) 9

Answer: C

226)

$$f(-9) \text{ for } f(x) = \begin{cases} 7x + 1, & \text{if } x < 9 \\ 9x, & \text{if } 9 \leq x \leq 13 \\ 9 - 9x, & \text{if } x > 13 \end{cases}$$

- A) -81
- B) 64
- C) 90
- D) -62

Answer: D

Sketch a graph of the function.

$$227) f(x) = \begin{cases} -2 & \text{if } x \geq 1 \\ -4 - x & \text{if } x < 1 \end{cases}$$

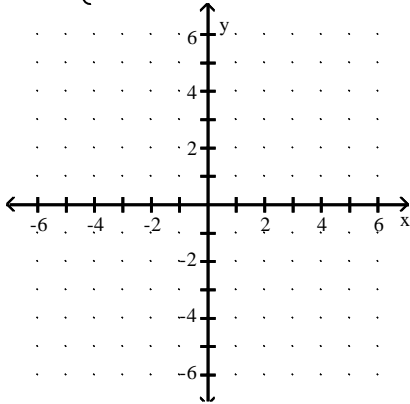

A)

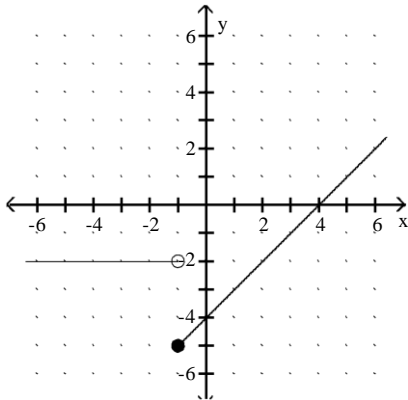

B)

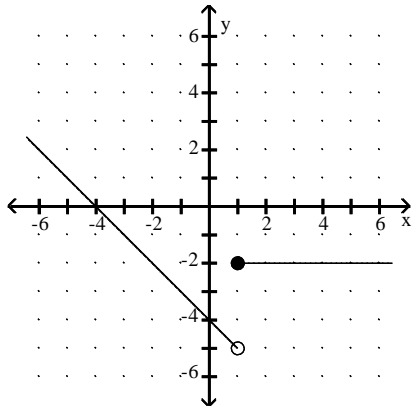

C)

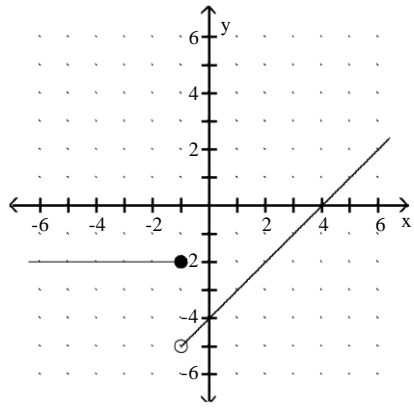

D)

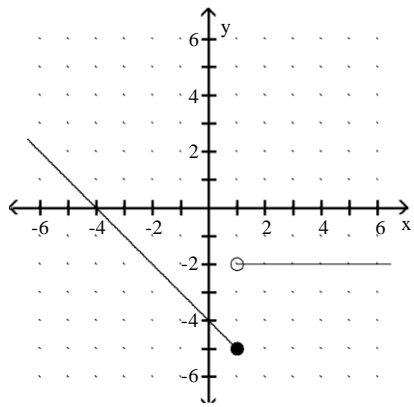

Answer: B

$$228) f(x) = \begin{cases} x+2 & \text{if } x > 0 \\ 4 & \text{if } x \leq 0 \end{cases}$$

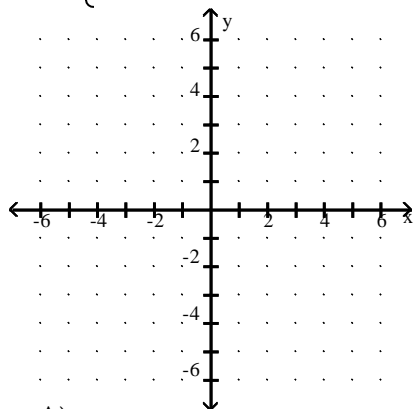

A)

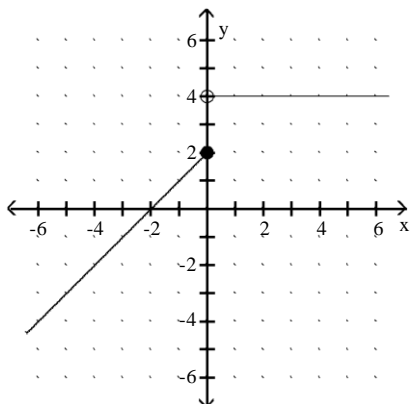

B)

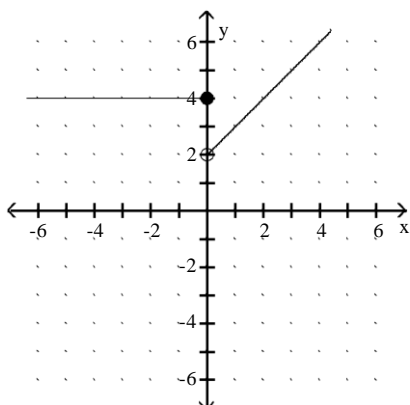

C)

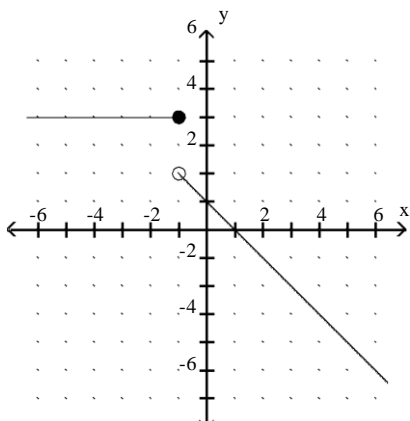

D)

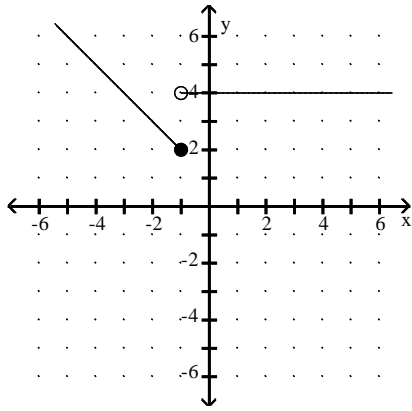

Answer: B

Graph f . Use the graph to determine whether f is continuous.
229)

$$f(x) = \begin{cases} -3x - 3 & \text{if } -2 \leq x \leq 0 \\ -x + 1 & \text{if } 0 < x \leq 3 \end{cases}$$

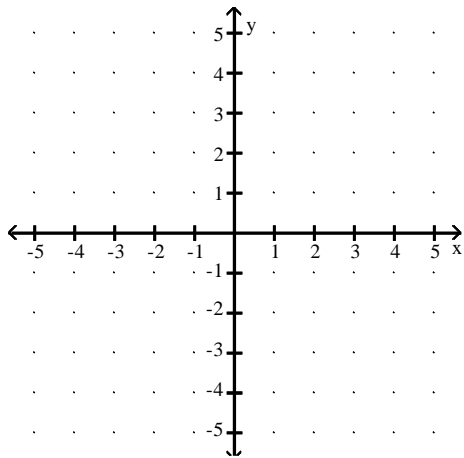

- A) Continuous
- B) Not continuous

Answer: B

230)

$$f(x) = \begin{cases} -3x - 3 & \text{if } -2 \leq x \leq 0 \\ -3 & \text{if } 0 < x < 3 \\ x - 6 & \text{if } 3 \leq x \leq 4 \end{cases}$$

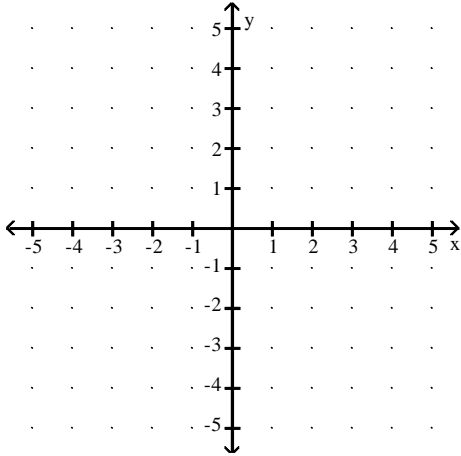

- A) Not continuous
- B) Continuous

Answer: B

Use dot mode to graph the function f in the standard viewing rectangle. Evaluate f for the given x -values.

231) $f(x) = \lceil \lceil x + 3 \rceil \rceil$ at $x = -2.5$ and $x = 0.8$

A)

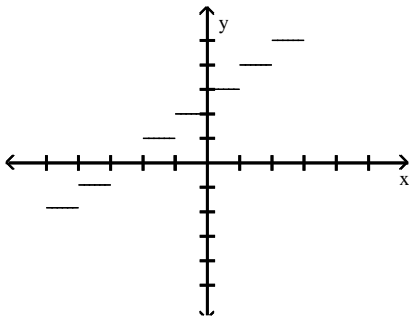

$f(-2.5) = 0, f(0.8) = 3$

B)

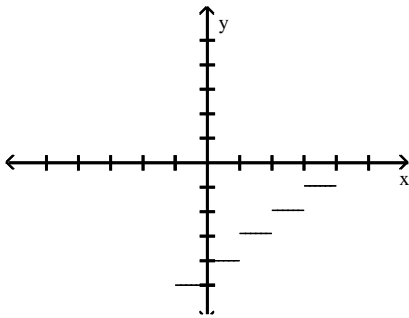

$f(-2.5) = 1, f(0.8) = 2$

C)

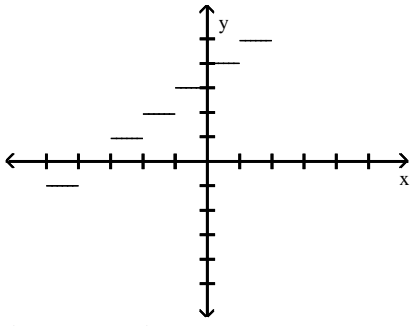

$$f(-2.5) = 0, f(0.8) = 2$$

D)

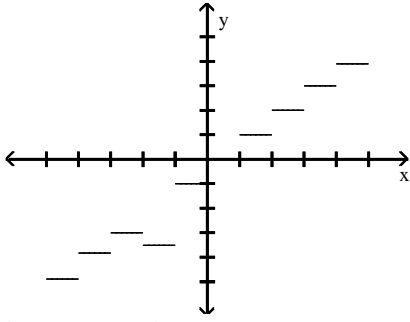

$$f(-2.5) = -2, f(0.8) = 0$$

Answer: A

232) $f(x) = \lceil x - 1 \rceil$ at $x = -0.7$ and $x = 1.7$

A)

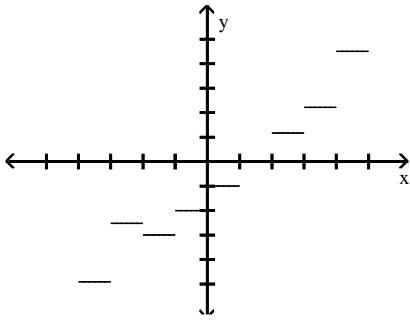

$$f(-0.7) = -1, f(1.7) = 0$$

B)

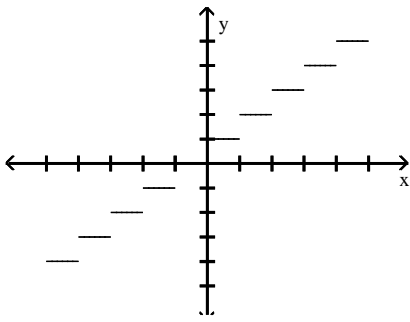

$$f(-0.7) = -1, f(1.7) = 1$$

C)

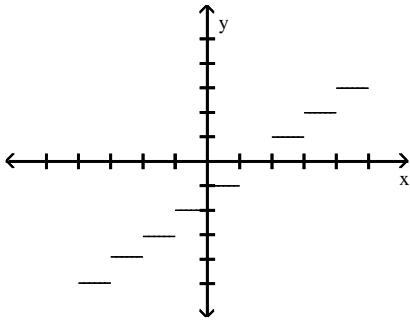

$$f(-0.7) = -2, f(1.7) = 0$$

D)

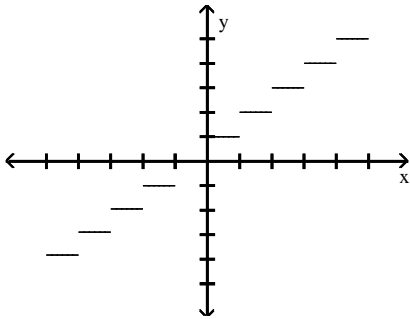

$$f(-0.7) = 1, f(1.7) = 2$$

Answer: C

233) $f(x) = \lceil x \rceil - 3$ at $x = -1.6$ and $x = 1.6$

A)

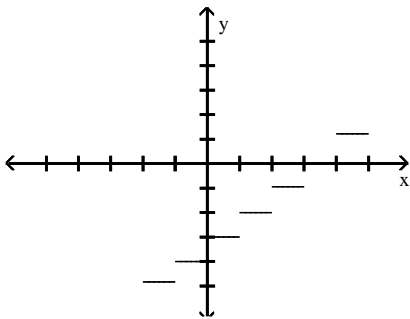

$$f(-1.6) = -5, f(1.6) = -2$$

B)

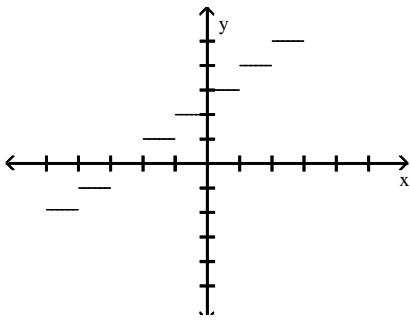

$$f(-1.6) = -4, f(1.6) = 0$$

C)

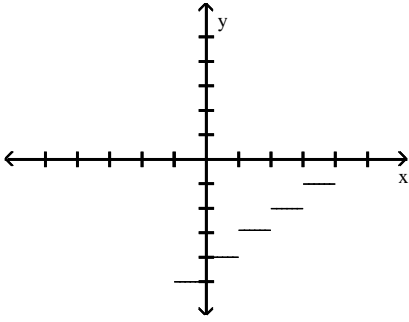

$$f(-1.6) = -6, f(1.6) = -4$$

D)

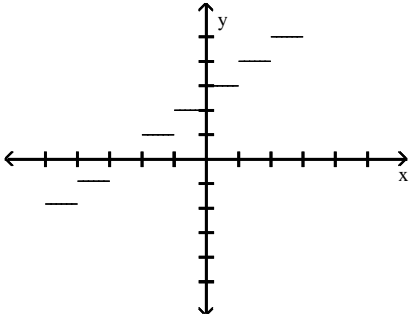

$$f(-1.6) = -3, f(1.6) = -2$$

Answer: A

234) $f(x) = \lceil \lceil -x \rceil \rceil$ at $x = -3.3$ and $x = 2.6$

A)

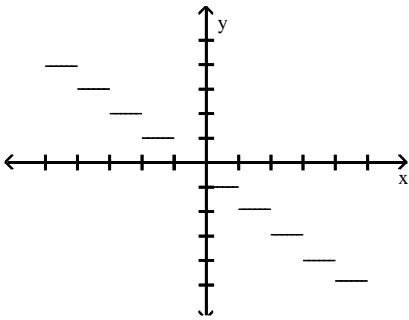

$$f(-3.3) = 3, f(2.6) = -3$$

B)

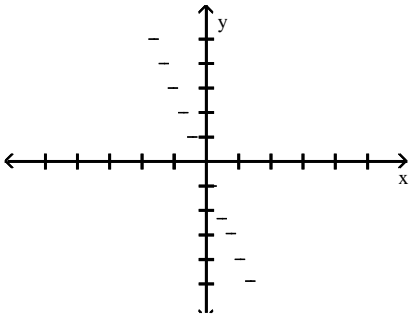

$$f(-3.3) = 2, f(2.6) = -1$$

C)

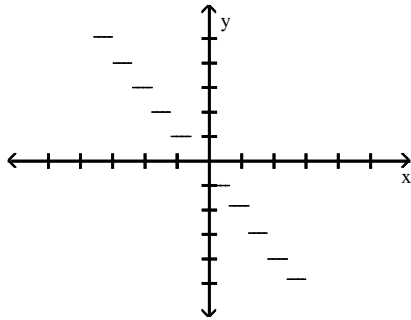

$$f(-3.3) = 1, f(2.6) = -3$$

D)

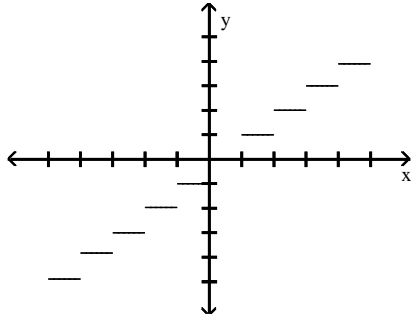

$$f(-3.3) = -4, f(2.6) = 2$$

Answer: A

Solve.

235) The time T necessary to make an enlargement of a photo negative is directly proportional to the area A of the enlargement. If 24 seconds are required to make a 3-by-4 enlargement, find the time required for a 4-by-9 enlargement.

- A) 72 sec
- B) 144 sec
- C) 108 sec
- D) 36 sec

Answer: A

236) The weight of a liquid is directly proportional to its volume V . If the weight of the liquid in a cubical container with side length 4 cm is 192 g, find the weight of the liquid in a cubical container 3 cm on a side.

- A) 9 g
- B) 81 g
- C) 15 g
- D) 27 g

Answer: B

237) The shadow cast by an object on a sunny day is directly proportional to the height of the object. If a person 73 inches tall casts a shadow 64 inches long, how tall is a tree which casts a shadow 48 feet in length?

- A) 68.5 feet
- B) 54.75 feet
- C) 97.33 feet
- D) 42.08 feet

Answer: B

- 238) The longest diagonal of a regular octagon (an eight-sided figure with all sides and angles equal) is directly proportional to the length of a side. If a regular octagon with sides 16 cm has a diagonal of length 16.22 cm, how long is the diagonal of an octagon with side 11 cm?
- A) 10.85 cm
 B) 0.11 cm
 C) 23.59 cm
 D) 11.15 cm

Answer: D

- 239) In the table, x is directly proportional to y . Find the undetermined value.

x	2.4	3.9	4.8	9.6
y	-20.4	-33.15	-40.8	?

- A) -8.5
 B) 81.6
 C) 8.5
 D) -81.6

Answer: D

Solve the equation.

- 240) $|x| = 11$
- A) -11
 B) -11, 11
 C) 121
 D) 11

Answer: B

- 241) $|r - 2| = 9$
- A) 7, 11
 B) -11
 C) No solution
 D) -7, 11

Answer: D

- 242) $|k| - 4 = 4$
- A) -8
 B) 8
 C) 0, 0
 D) 8, -8

Answer: D

- 243) $|b - 6| - 4 = 1$
- A) 11, 1
 B) 11
 C) -11, -1
 D) No solution

Answer: A

244) $|7m + 5| + 8 = 14$

A) $\frac{1}{5}, -\frac{11}{5}$

B) $-\frac{1}{7}, \frac{11}{7}$

C) $\frac{1}{7}, -\frac{11}{7}$

D) No solution

Answer: C

245) $|y| = -16$

A) -16

B) $\frac{1}{16}$

C) No solution

D) 16

Answer: C

246) $|x| = 3.5$

A) 0.29, -0.29

B) 3.5

C) -3.5

D) 3.5, -3.5

Answer: D

247) $|6m + 4| = 5$

A) $\frac{1}{4}, -\frac{9}{4}$

B) $\frac{1}{6}, -\frac{3}{2}$

C) $-\frac{1}{6}, \frac{3}{2}$

D) No solution

Answer: B

Solve the absolute value inequality. Write the solution set using interval notation.

248) $|x| > 8$

A) $(-8, \infty)$

B) $(-\infty, -8) \cup (8,$

$\infty)$ C) $(8, \infty)$

D) $(-8, 8)$

Answer: B

249) $|x| \leq 17$

A) $(-\infty, 17]$

B) $(-\infty, -17]$

C) $[-17, 17]$

D) $(-\infty, -17] \cup [17,$

$\infty)$ Answer: C

$$250) |4x - 2| \geq 3$$

- A) $\left[-\frac{1}{4}, \frac{5}{4}\right]$
- B) $\left[\frac{5}{4}, \infty\right)$
- C) $\left(-\infty, -\frac{1}{4}\right] \cup \left[\frac{5}{4}, \infty\right)$
- D) $\left(-\infty, -\frac{5}{4}\right] \cup [3, \infty)$

Answer: C

$$251) |4x + 1| < 2$$

- A) $\left(-\infty, -\frac{3}{4}\right)$
- B) $\left(-\frac{3}{4}, \frac{1}{4}\right]$
- C) $\left(-\infty, -\frac{3}{4}\right) \cup \left(\frac{1}{4}, \infty\right)$
- D) $(-\infty, 4)$

Answer: B

$$252) |r + 0.8| < 3$$

- A) $(-3.8, 2.2)$
- B) $(-2.2, 3.8)$
- C) $(-\infty, -2.2) \cup (3.8, \infty)$
- D) $(-\infty, -3.8) \cup (2.2, \infty)$

Answer: A

$$253) |b - 3| - 7 > 2$$

- A) $(-\infty, -6) \cup (-2, \infty)$
- B) $(-\infty, 2) \cup (6, \infty)$
- C) $(-\infty, -6) \cup (12, \infty)$
- D) $(-6, 12)$

Answer: C

$$254) |x - 6| < 4$$

- A) $\left(-\frac{46}{7}, -\frac{38}{7}\right)$
- B) $\left(\frac{38}{7}, \frac{46}{7}\right)$
- C) $\left(-\infty, -\frac{46}{7}\right) \cup \left(-\frac{38}{7}, \infty\right)$
- D) $\left(-\infty, \frac{38}{7}\right) \cup \left(\frac{46}{7}, \infty\right)$

Answer: B

255) $|x + 2| \geq 7$

- A) $\left(-\infty, -\frac{23}{8}\right] \cup \left[-\frac{9}{8}, \infty\right)$
- B) $\left(-\infty, \frac{23}{8}\right] \cup \left[\frac{9}{8}, \infty\right)$
- C) $\left(-\infty, -\frac{9}{8}\right] \cup \left[-\frac{23}{8}, \infty\right)$
- D) $\left[-\frac{23}{8}, -\frac{9}{8}\right]$

Answer: A

256) $\left|\frac{x-4}{7}\right| \geq 4$

- A) $(-\infty, -24] \cup [32, \infty)$
- B) $[-24, 32]$
- C) $(-\infty, -24] \cap [32, \infty)$
- D) $(-24, 32)$

Answer: A

257) $\left|\frac{5-2x}{6}\right| \leq 2$

- A) $\left(-\infty, -\frac{7}{2}\right) \cap \left(\frac{17}{2}, \infty\right)$
- B) $\left(-\infty, -\frac{7}{2}\right) \cup \left[\frac{17}{2}, \infty\right)$
- C) $\left[-\frac{7}{2}, \frac{17}{2}\right]$
- D) \emptyset

Answer: C

Graph $y = f(x)$ and $y = |f(x)|$ in the standard viewing rectangle. Determine the x-intercept for the graph of $y = |f(x)|$.

258) $y = 2x$

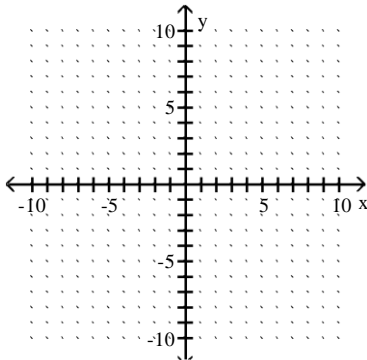

A)

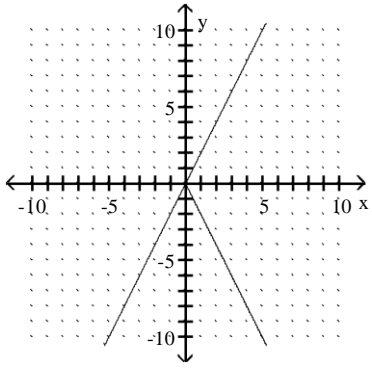

x-intercept is

0. B)

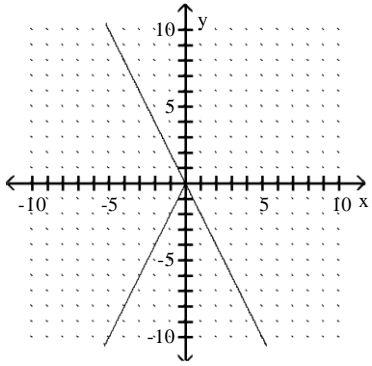

x-intercept is

0. C)

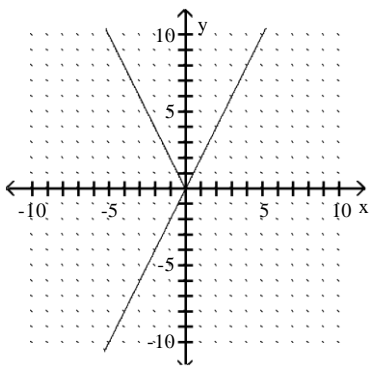

x-intercept is

0. D)

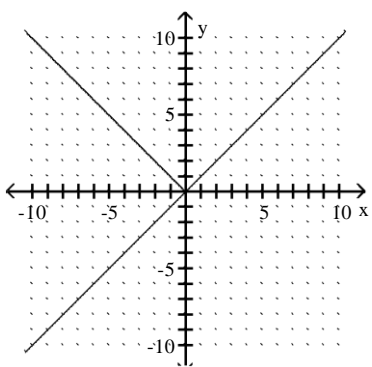

x-intercept is

0. Answer: C

259) $y = -0.9x$

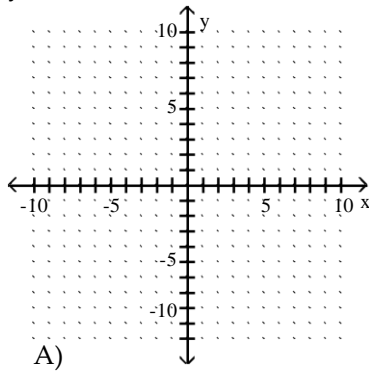

A)

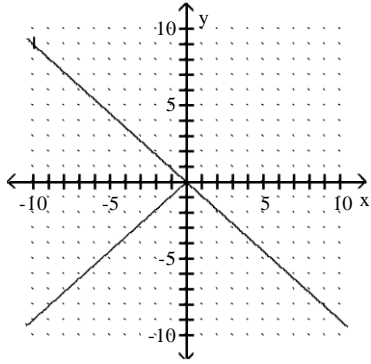

x-intercept is

0. B)

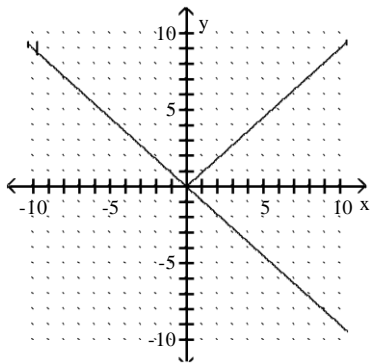

x-intercept is

0. C)

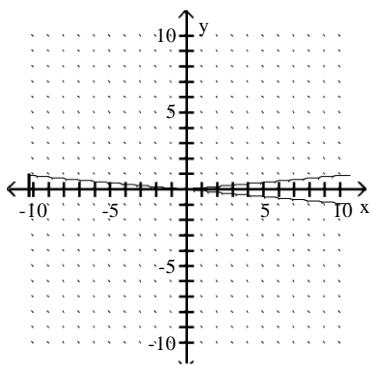

x-intercept is 0.

D)

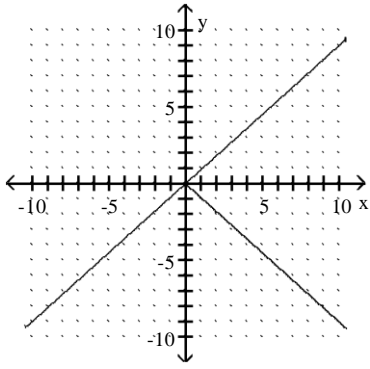

x-intercept is

0. Answer: B

260) $y = 3x + 3.6$

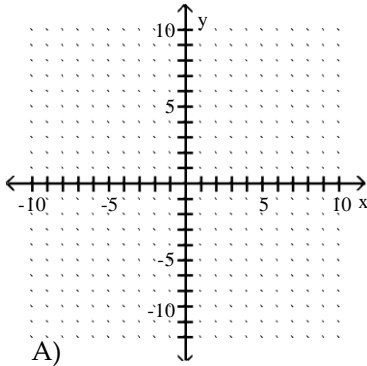

A)

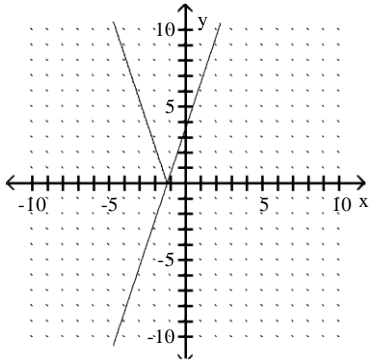

x-intercept is -

1.2. B)

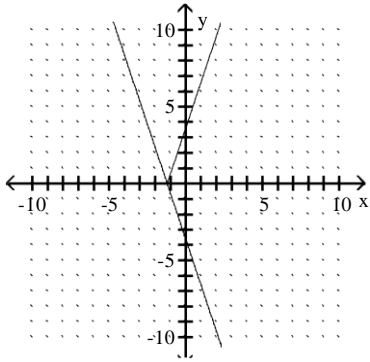

x-intercept is 1.2.

C)

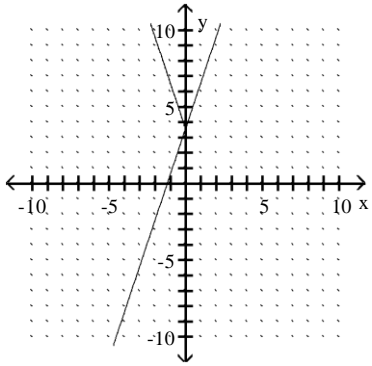

x-intercept is

3. D)

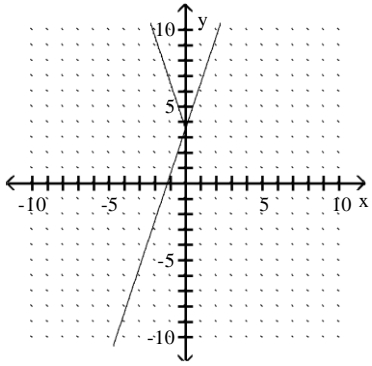

x-intercept is

0. Answer: A

261) $y = 3x - 4.2$

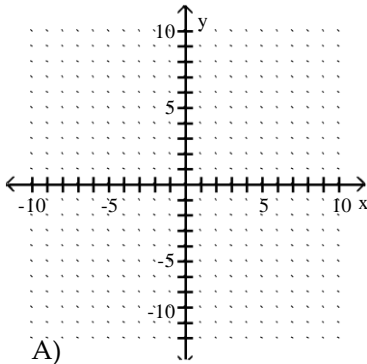

A)

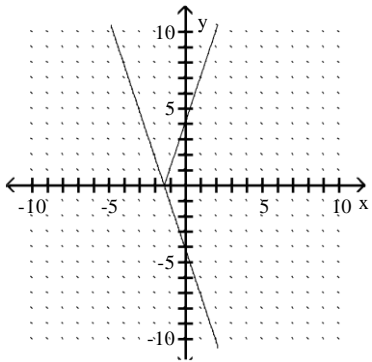

x-intercept is -1.4.

B)

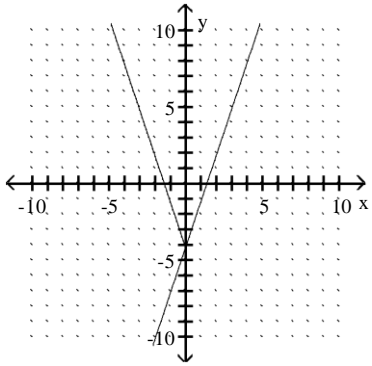

x-intercept is

0. C)

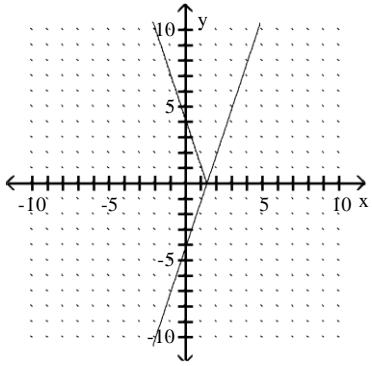

x-intercept is

1.4. D)

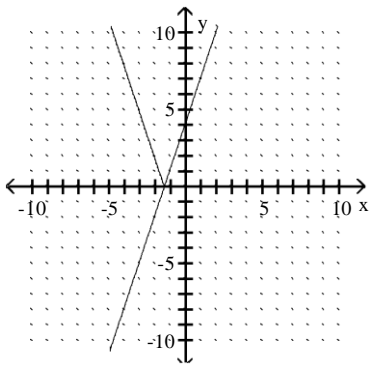

x-intercept is -

1.4. Answer: C

262) $y = 9 - 3x$

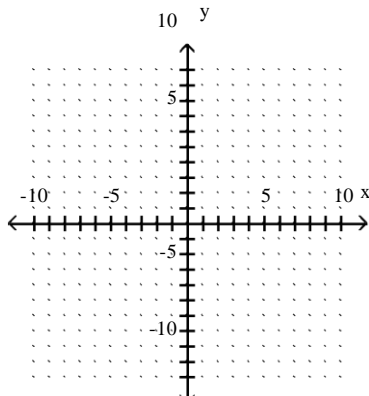

A)

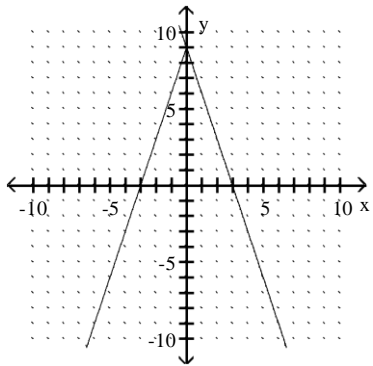

x-intercept is

0. B)

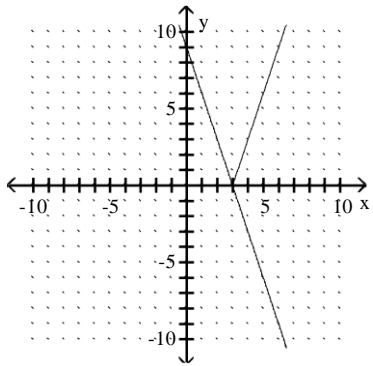

x-intercept is

3. C)

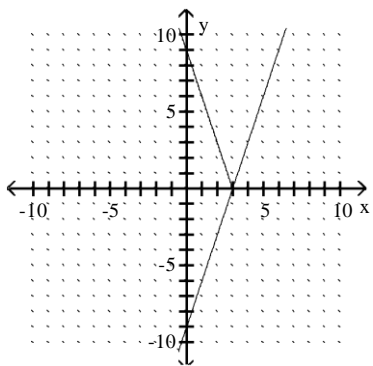

x-intercept is

3. D)

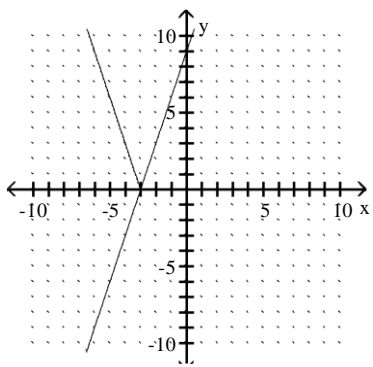

x-intercept is -

3. Answer: B

263) $y = 3 - 6x$

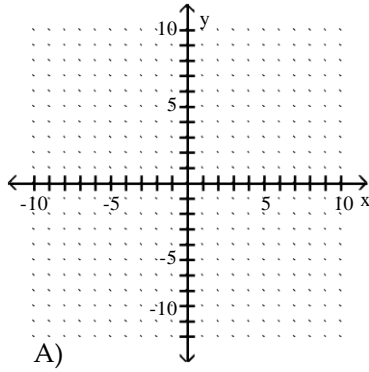

A)

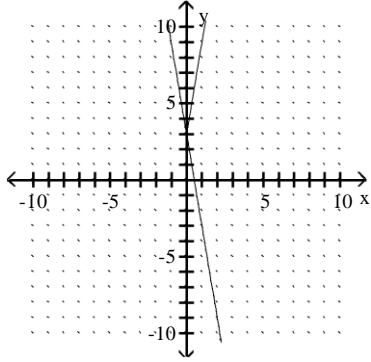

x-intercept is

0. B)

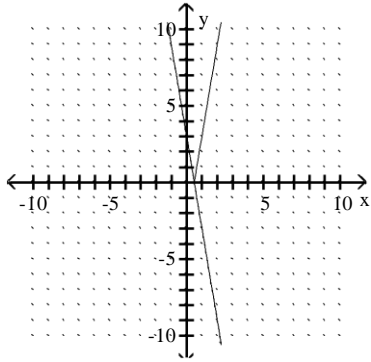

x-intercept is

0.5. C)

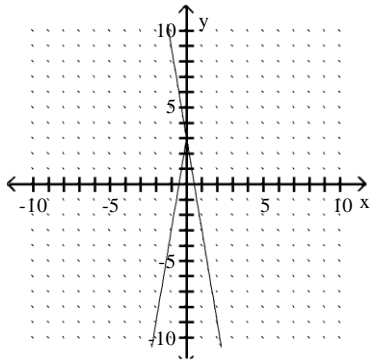

x-intercept is 0.

D)

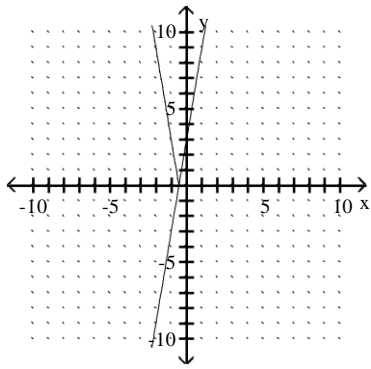

x-intercept is -

0.5. Answer: B

Solve the equation graphically, numerically, or symbolically. If appropriate, round the solution to hundredths.

264) $|x| = 11$

- A) 11, -11
- B) 121
- C) -11
- D) 11

Answer: A

265) $|k| - 6 = -3$

- A) 3
- B) -3
- C) -9, 9
- D) 3, -3

Answer: D

266) $|x| = -15$

- A) -15
- B) 0.07
- C) 15
- D) No solution

Answer: D

267) $|r - 6| = 2$

- A) No solution
- B) 8, 4
- C) 8, -4
- D) -8

Answer: B

268) $|b - 4| - 9 = -2$

- A) 11, -3
- B) 11
- C) -11, 3
- D) No solution

Answer: A

- 269) $|7m + 5| + 8 = 16$
A) 0.43, -1.86
B) 0.6, -2.6
C) No solution
D) -0.43, 1.86

Answer: A

- 270) $|t + 5| = 0$
A) 5
B) -5, 5
C) No solution
D) -5

Answer: D

- 271) $|8f - 4| + 3 = -6$
A) No solution
B) -1.62, -0.62
C) 1.63, 0.63
D) -0.62

Answer: A

Provide an appropriate response.

- 272) The graphs of two linear functions f and g are shown in the figure. Solve (i) the equation $f(x) = g(x)$ and (ii) the inequality $g(x) < f(x)$.

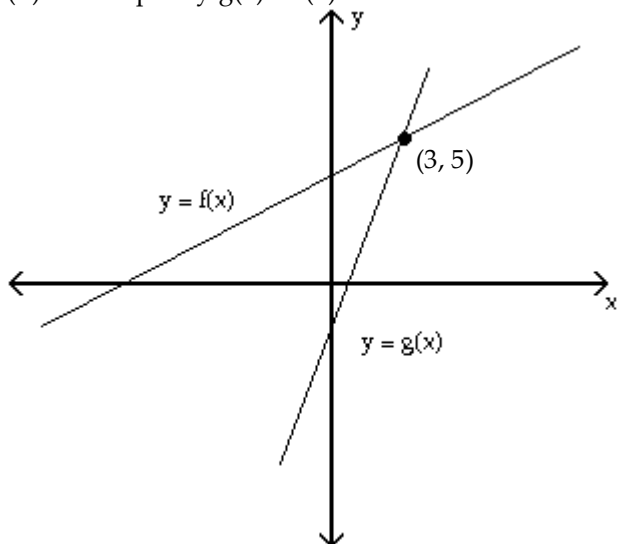

- A) $x = 0$; $0 < x < 3$
B) $x = 3$; $x < 3$
C) $x = 3$; $x < 5$
D) $x = 5$; $x < 5$

Answer: B

Solve the inequality graphically, numerically, or symbolically, and express the solution in interval notation. Where appropriate, round to the nearest tenth.

273) $|r + 6| < 2$

- A) $(-\infty, 4) \cup (8, \infty)$
- B) $(-8, -4)$
- C) $(4, 8)$
- D) $(-\infty, -8) \cup (-4,$

$\infty)$ Answer: B

274) $|b - 2| + 1 > 18$

- A) $(-\infty, -21) \cup (15, \infty)$
- B) $(-\infty, -15) \cup (19, \infty)$
- C) $(-15), (19)$
- D) $(-\infty, -15) \cup (21, \infty)$

Answer: B

275) $6|x - 4| < 7$

- A) $\left(\frac{17}{6}, \frac{31}{6}\right)$
- B) $\left(-\infty, -\frac{31}{6}\right) \cup \left(-\frac{17}{6}, \infty\right)$
- C) $\left(-\infty, \frac{17}{6}\right) \cup \left(\frac{31}{6}, \infty\right)$
- D) $\left(-\frac{31}{6}, -\frac{17}{6}\right)$

Answer: A

276) $9|x + 5| \geq 3$

- A) $\left(-\frac{14}{3}, -\frac{16}{3}\right)$
- B) $\left(-\infty, -\frac{14}{3}\right) \cup \left(-\frac{16}{3}, \infty\right)$
- C) $\left(-\infty, -\frac{16}{3}\right) \cup \left(-\frac{14}{3}, \infty\right)$
- D) $\left(-\infty, \frac{16}{3}\right) \cup \left(\frac{14}{3}, \infty\right)$

Answer: C

277) $|2.4x - 5| \leq 4$

- A) $(-\infty, 3.8) \cup (0.4,$
- $\infty)$ B) $(0.4, 3.8)$
- C) $(-\infty, 0.4) \cup (3.8,$
- $\infty)$ D) $[0.4, 3.8]$

Answer: D

- 278) $|2.7x + 8.1| > 2$
A) $(-3.7, -2.3)$
B) $(-2.3, -3.7)$
C) $(-\infty, -3.7) \cup (-2.3, \infty)$
D) $(-\infty, -2.3) \cup (-3.7, \infty)$
Answer: C

Solve the problem.

- 279) The inequality $|T - 35| \leq 18$ describes the range of monthly average temperatures T in degrees Fahrenheit at a City X. (i) Solve the inequality. (ii) If the high and low monthly average temperatures satisfy equality, interpret the inequality.
A) $17 \leq T \leq 53$; The monthly averages are always within 18° of 35°F .
B) $T \leq 53$; The monthly averages are always less than or equal to 53°F .
C) $14 \leq T \leq 56$; The monthly averages are always within 21° of 35°F .
D) $14 \leq T$; The monthly averages are always greater than or equal to 14°F .

Answer: A

- 280) The inequality $|T - 9| \leq 17$ describes the range of monthly average temperatures T in degrees Fahrenheit at a City X. (i) Solve the inequality. (ii) If the high and low monthly average temperatures satisfy equality, interpret the inequality.
A) $26 \leq T \leq 43$; The monthly averages are always within 34° of 9°F .
B) $-16 \leq T \leq 34$; The monthly averages are always within 25° of 9°F .
C) $-8 \leq T \leq 26$; The monthly averages are always within 17° of 9°F .
D) $34 \leq T \leq 59$; The monthly averages are always within 50° of 9°F .

Answer: C

- 281) The inequality $|T - 35.3| \leq 9.7$ describes the range of monthly average temperatures T in degrees Fahrenheit at a City X. (i) Solve the inequality. (ii) If the high and low monthly average temperatures satisfy equality, interpret the inequality.
A) $-45 \leq T \leq 54.7$; The monthly averages are always within 19.4° of 35.3°F .
B) $25.6 \leq T \leq 45$; The monthly averages are always within 9.7° of 35.3°F .
C) $31.2 \leq T \leq 39.4$; The monthly averages are always within 4.1° of 35.3°F .
D) $-39.4 \leq T \leq 43.5$; The monthly averages are always within 8.2° of 35.3°F .

Answer: B