

**Test Bank for Precalculus A Right Triangle Approach 3rd Edition Ratti  
McWaters 0321912764 9780321912763**

**Full link download**

**Test Bank:**

<https://testbankpack.com/p/test-bank-for-prec calculus-a-right-triangle-approach-3rd-edition-ratti-mcwaters-0321912764-9780321912763/>

**Solution Manual:**

<https://testbankpack.com/p/solution-manual-for-prec calculus-a-right-triangle-approach-3rd-edition-ratti-mcwaters-0321912764-9780321912763/>

MULTIPLE CHOICE. Choose the one alternative that best completes the statement or answers the question.

Plot the point and state the quadrant, if any, in which the point is located.

1)  $(6, 1)$

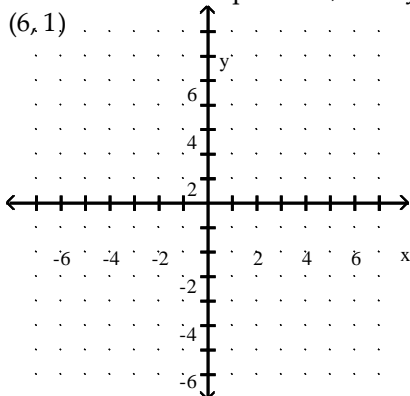

A) Quadrant I

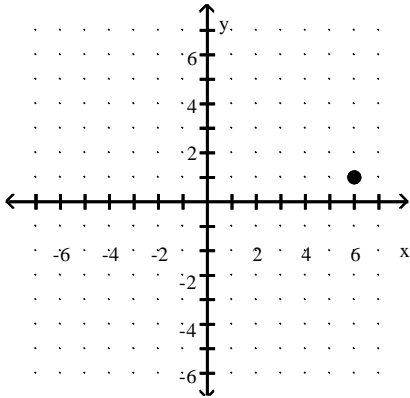

B) Quadrant IV

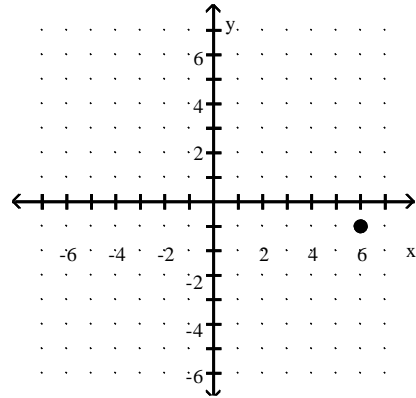

C) Quadrant II

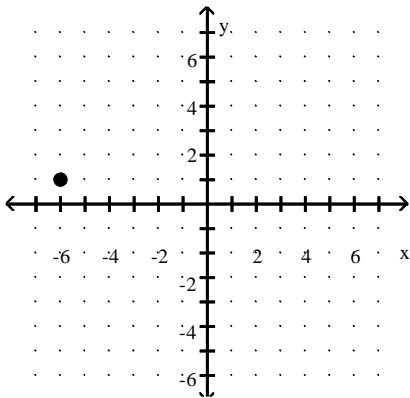

D) Quadrant I

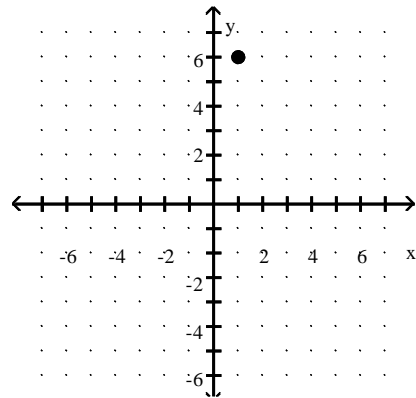

Answer: A

2)  $(-3, 4)$

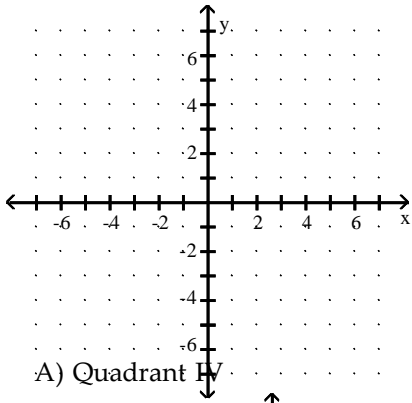

A) Quadrant IV

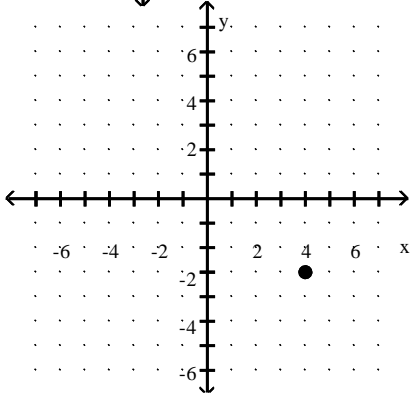

B) Quadrant III

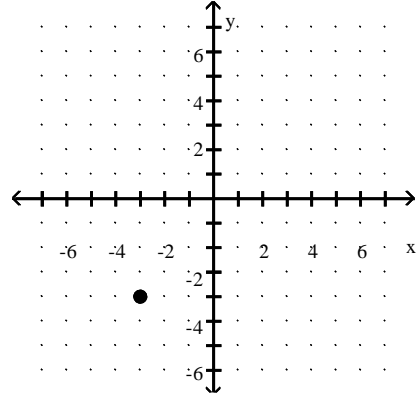

C) Quadrant II

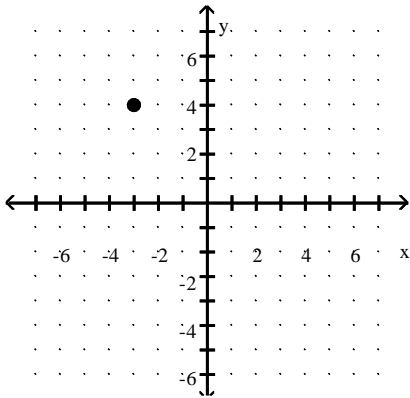

D) Quadrant I

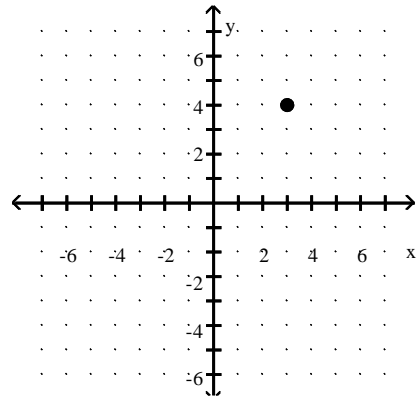

Answer: C

3)  $(6, -1)$

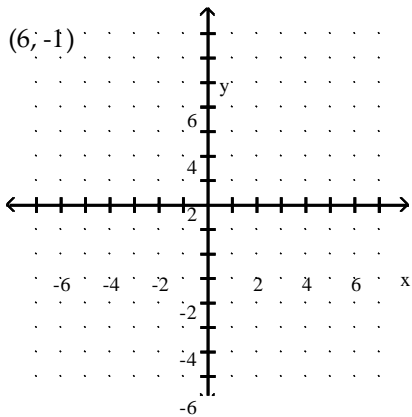

A) Quadrant III

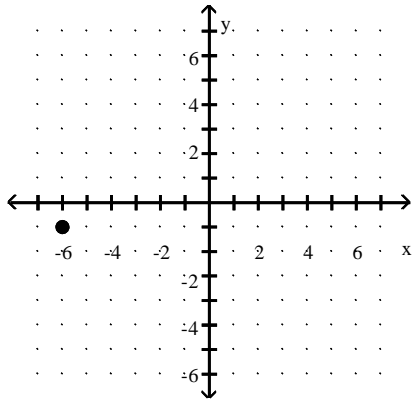

B) Quadrant II

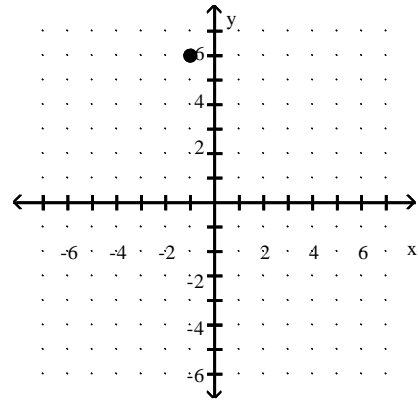

C) Quadrant I

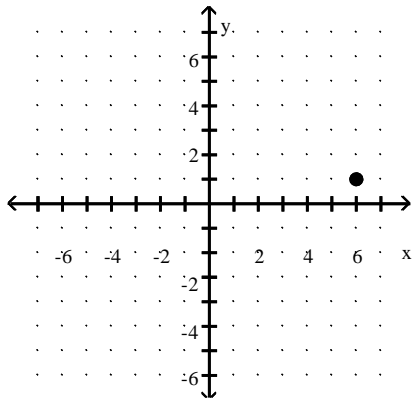

D) Quadrant IV

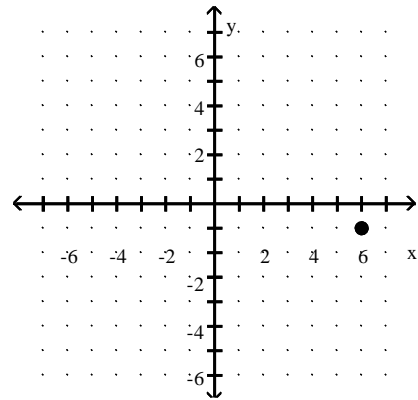

Answer: D

4) (-1, -2)

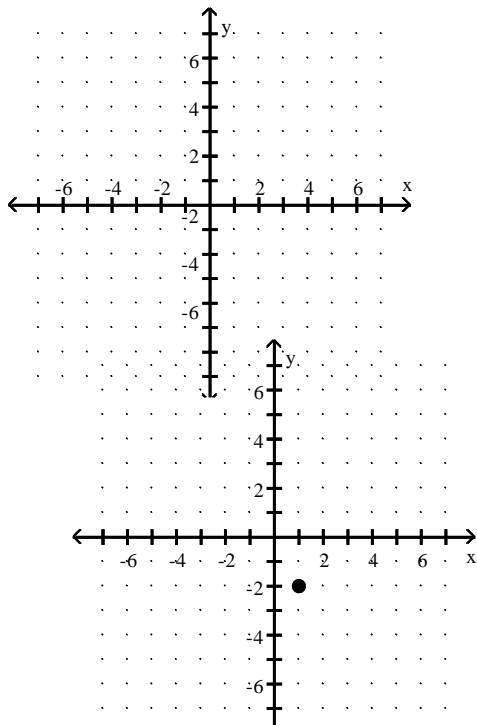

A) Quadrant IV

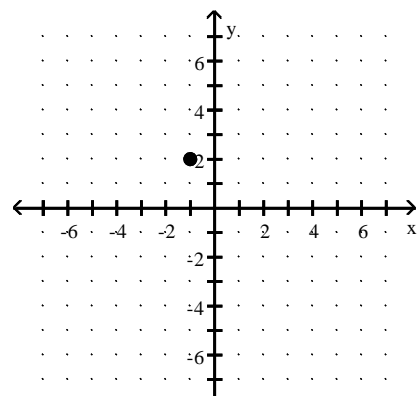

B) Quadrant II

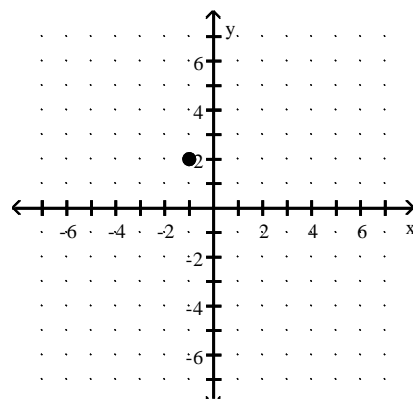
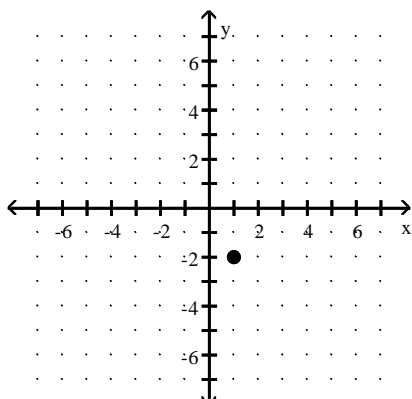

C) Quadrant III

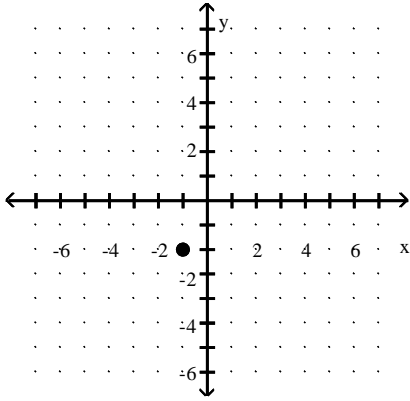

D) Quadrant III

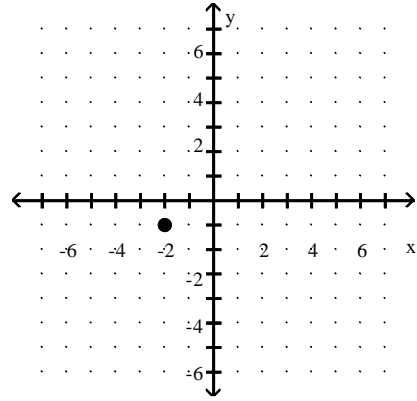

Answer: C

5) (0, 5)

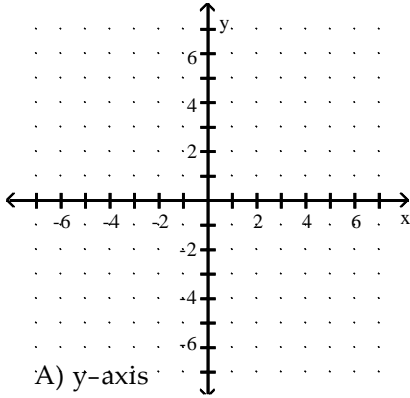

A) y-axis

B) x-axis

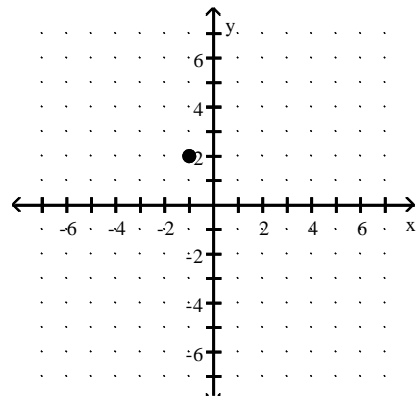
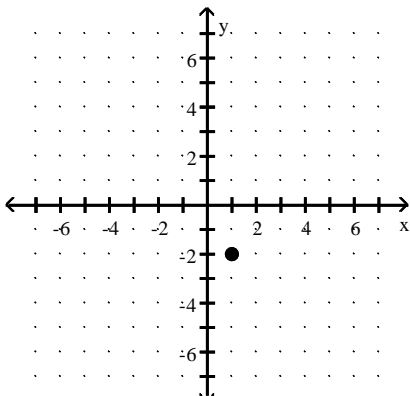
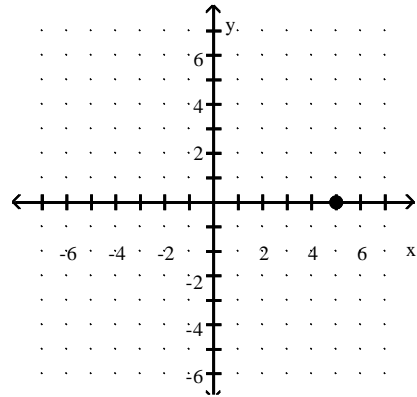
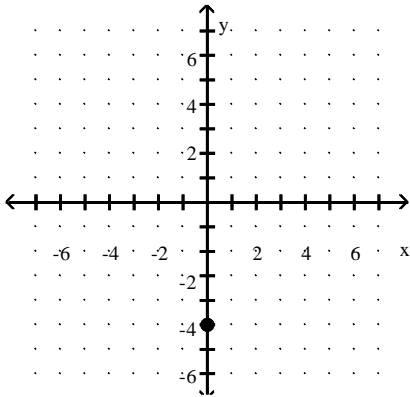

C) y-axis

D) Quadrant I

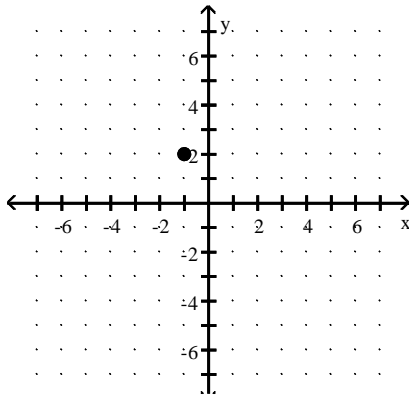
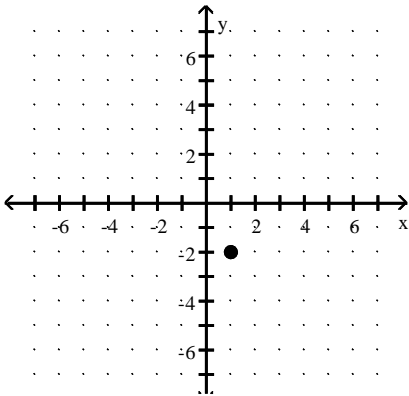

Answer: C

6)  $(-6, 0)$

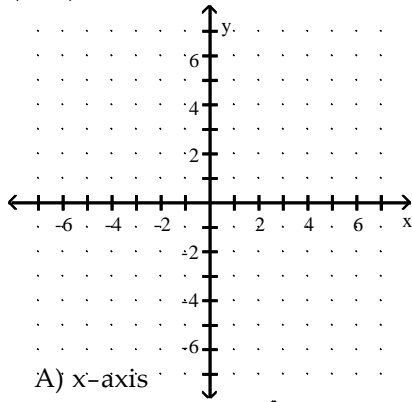

A) x-axis

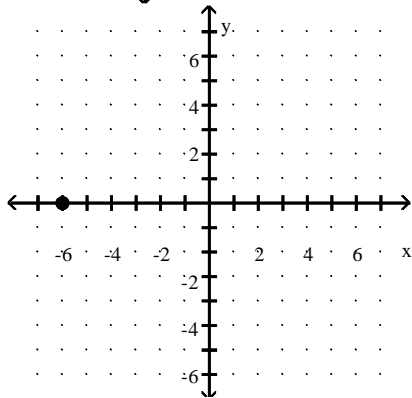

B) Quadrant I

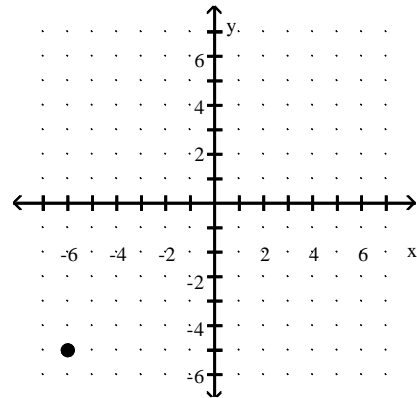

C) x-axis

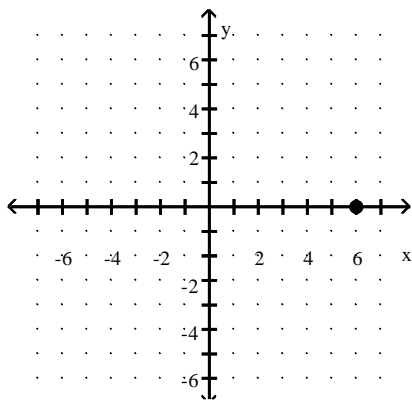

D) y-axis

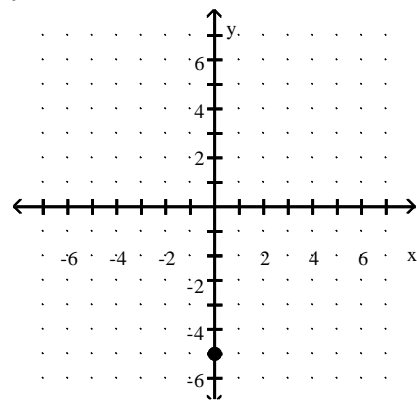

Answer: A

Find the distance between P and Q.

7)  $P(5, 3)$ ,  $Q(-3, 9)$

A) 20

B) 11

C) 100

D) 10

Answer: D

8)  $P(4, 3)$ ,  $Q(-5, -$

A)  $\sqrt{17}$

B)  $\sqrt{145}$

C) 1

D) 72

Answer: B



9) P(2, -1), Q(6, -3)

A) 6

B) 12

C)  $12\sqrt{3}$

D)  $2\sqrt{5}$

Answer: D

10) P(-6, -4), Q(6, -7)

A) 135

B)  $135\sqrt{15}$

C)  $3\sqrt{17}$

D) 15

Answer: C

11) P(u - v, t), Q(u + v,

A)  $2|u^2 - t^2|$

B)  $|v|$

C)  $2|v|$

D)  $|u^2 - t^2|$

Answer: C

12) P(y, z), Q(z, y)

A)  $\sqrt{2|y+z|}$

B)  $\sqrt{2|y-z|}$

C)  $2|y-z|$

D)  $2|y+z|$

Answer: B

Find the coordinates of the midpoint of the line segment PQ.

13) P(6, 7), Q(8, 9)

A) (14, 16)

B) (8, 7)

C) (-2, -2)

D) (7, 8)

Answer: D

14) P(-1, -9), Q(-8, -8)

A)  $\left(-\frac{17}{2}, -\frac{9}{2}\right)$

B) (7, -1)

C)  $\left(-\frac{9}{2}, -\frac{17}{2}\right)$

D) (-9, -17)

Answer: C

15) P(7x, 3), Q(8x, 4)

A) (x, 1)

B)  $\left(\frac{15x}{2}, \frac{7}{2}\right)$

C)  $\left(\frac{7x}{2}, \frac{15}{2}\right)$

D) (15x, 7)

Answer: B

16) P(u - w, t), Q(u + w, t)

A) (2u, 2t)

B) (u, t)

C) (-w, 0)

D) (t, u)

Answer: B

17) P(y, z), Q(z, y)

A)  $\left(\frac{yz}{2}, \frac{yz}{2}\right)$

B)  $\left(\frac{y+z}{2}, \frac{y+z}{2}\right)$

C) (y + z, y + z)

D) (yz, yz)

Answer: B

Determine whether the given points are collinear.

18) (-1, -2), (5, 16), (2, 7)

A) Yes

B) No

Answer: A

19) (-4, 5), (4, -3), (-2, 1)

A) Yes

B) No

Answer: B

Identify the triangle PQR as isosceles, equilateral, or scalene.

20)  $P(0, 0)$ ,  $Q(-8, 5)$ ,  $R(-3, 13)$

A) Isosceles

B) Scalene

C) Equilateral

Answer: A

21)  $P(5, -1)$ ,  $Q(7, -4)$ ,  $R(0, -4)$

A) Equilateral

B) Scalene

C) Isosceles

Answer: B

22)  $P(12, -12)$ ,  $Q(-12, 12)$ ,  $R(-12\sqrt{3}, -12\sqrt{3})$

A) Scalene

B) Isosceles

C) Equilateral

Answer: C

Solve the problem.

23) The graph shows the Total Gross Revenue (in millions of dollars) of Top 100 Internet Companies in the United

States between 2000 and 2004. Use the midpoint formula to estimate the revenue for 2002.

Total Gross Revenue of Top 100 Internet Companies

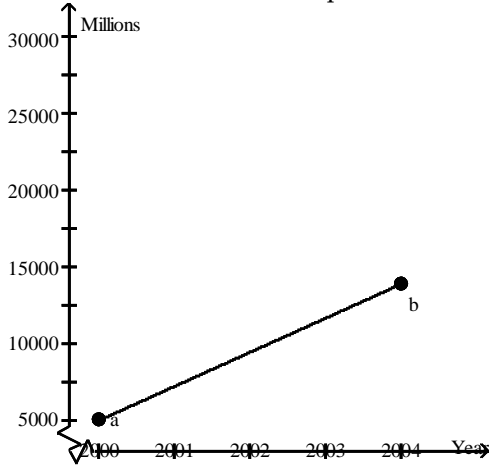

$a = 5000$  million dollars;  $b = 13,800$  million dollars

A) 9400 million dollars

B) 26,000 million dollars

C) 17,500 million dollars

D) 8800 million dollars

Answer: A

24) The graph shows an idealized linear relationship for the average monthly payments (in dollars) to retirees from 2000 through 2004. Use the midpoint formula to estimate the payment for 2002.

Average Monthly Payments to Retirees

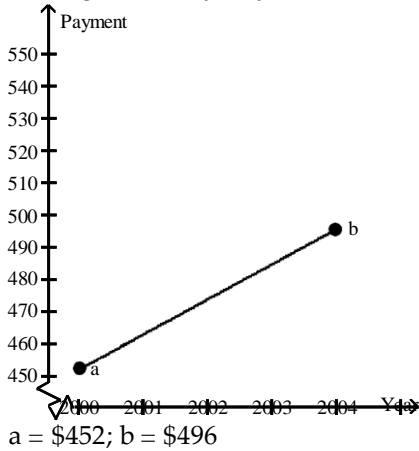

- A) \$474                                      B) \$22                                      C) \$500                                      D) \$496

Answer: A

25) The table lists how financial aid income cutoffs (in dollars) for a family of four have changed over time. Use the midpoint formula to approximate the financial aid cutoff for 1985.

| Year | Income (in dollars) |
|------|---------------------|
| 1960 | 21,000              |
| 1970 | 27,000              |
| 1980 | 33,000              |
| 1990 | 39,000              |
| 2000 | 45,000              |

- A) \$18,000                                      B) \$57,000                                      C) \$21,000                                      D) \$36,000

Answer: D

26) The table shows the total yearly attendance at home football games in thousands. The attendance numbers are rounded to the nearest thousand. Plot the data in a Cartesian coordinate system.

| Year | Attendance |
|------|------------|
| 1980 | 546        |
| 1985 | 617        |
| 1990 | 699        |
| 1995 | 735        |
| 2000 | 849        |
| 2005 | 882        |

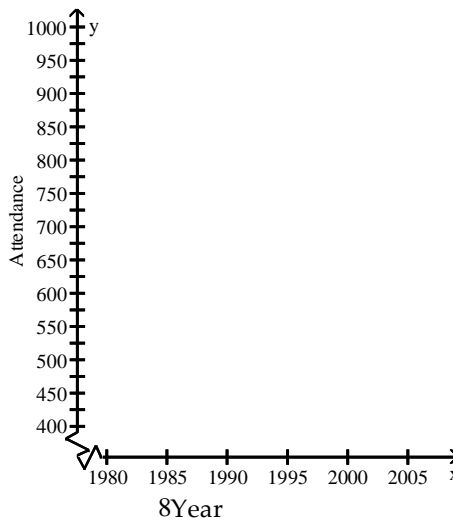

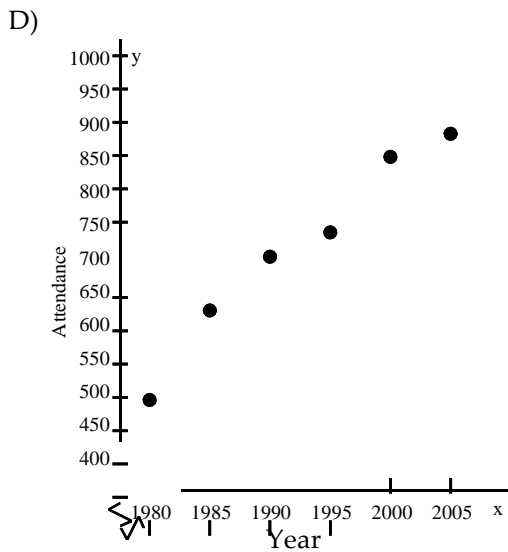
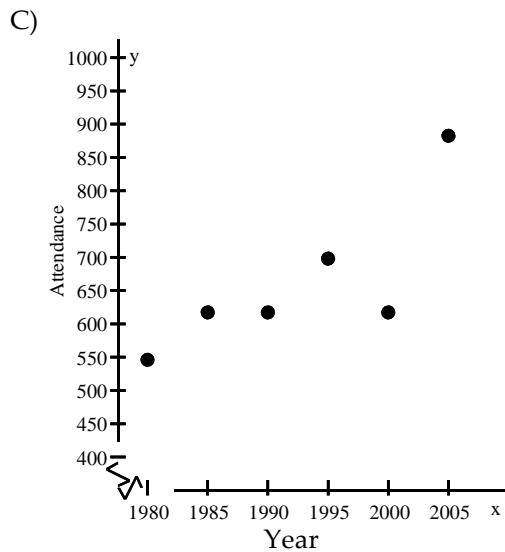
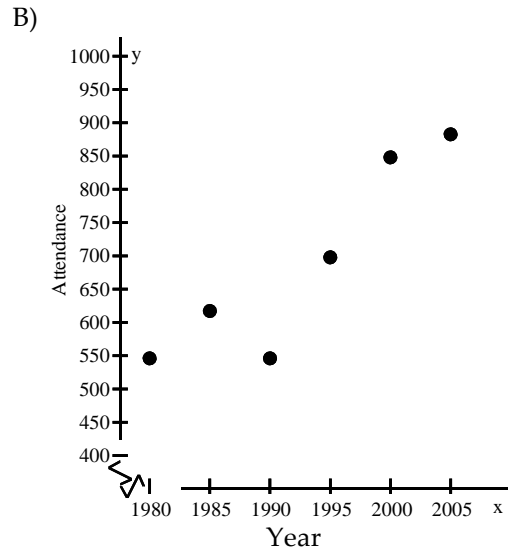
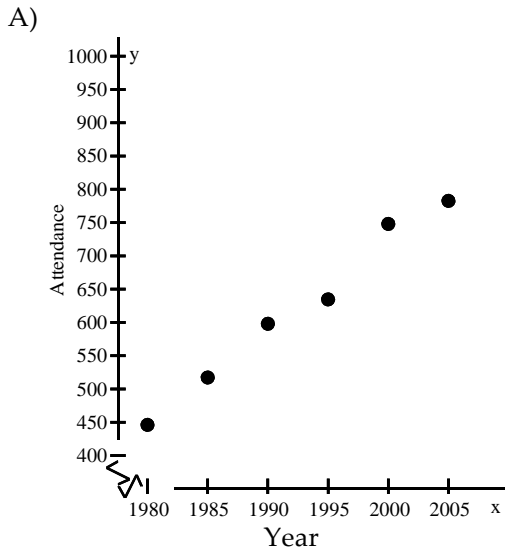

Answer: D

27) A family is driving from Algebraville to Geometry City to Trig Town. With reference to the origin, Algebraville is located at (1, 3), Geometry City at (7, 11), and Trig Town at (19, 2), all numbers being in 1000-mile units. Find the distance traveled by the family. If necessary, round your answer to the nearest whole number.

- A) 25,000 mi                      B) 25 mi                      C) 15,000 mi                      D) 10,000 mi

Answer: A

28) A family is driving from Algebraville to Geometry City to Trig Town. With reference to the origin, Algebraville is located at (3, 4), Geometry City at (5, 10), and Trig Town at (18, 4), all numbers being in 1000-mile units. Find the distance from Algebraville directly to Trig Town. If necessary, round your answer to the nearest whole number.

- A) 15,000 mi                      B) 16,155 mi                      C) 15 mi                      D) 6325 mi

Answer: A

Provide an appropriate response.

29) Determine the quadrants in which the given point  $(x, y)$  may lie when  $xy > 0$ .

- A) II or IV                      B) I or II                      C) I or III                      D) II or III

Answer: C

- 30) Determine the quadrants in which the given point  $(x, y)$  may lie when  $x < 0$ .  
A) III or IV                      B) I or IV                      C) II or IV                      D) II or III

Answer: D

- 31) Find all the points having an x-coordinate of 9 whose distance from the point  $(3, -2)$  is 10.  
A)  $(9, 13), (9, -7)$                       B)  $(9, 6), (9, -10)$                       C)  $(9, -12), (9, 8)$                       D)  $(9, 2), (9, -4)$

Answer: B

- 32) The points  $(-1, 6), (2, 9), (4, 1)$ , and  $(7, 4)$  are the vertices of a quadrilateral. Is the quadrilateral a rectangle?  
A) Yes                                      B) No

Answer: A

- 33) The points  $(1, 9), (4, 8), (6, 0)$ , and  $(9, 3)$  are the vertices of a quadrilateral. Is the quadrilateral a rectangle?  
A) Yes                                      B) No

Answer: B

- 34) Graph the rectangle with vertices  $(3, 6), (6, 9), (8, 1)$ , and  $(11, 4)$ . Are the midpoints of the sides of the rectangle the vertices of a rectangle?

A) Yes                                      B) No

Answer: A

- 35) Graph the rectangle with vertices  $(-1, 5), (2, 8), (4, 0)$ , and  $(7, 3)$ . Are the midpoints of the sides the vertices of a square?

A) Yes                                      B) No

Answer: B

Determine whether the given point is on the graph of the equation.

- 36)  $y = 7x - 3; (-1, -10)$   
A) Yes                                      B) No

Answer: A

- 37)  $7y = -5x + 8; \left(0, \frac{8}{7}\right)$   
A) Yes                                      B) No

Answer: B

- 38)  $2x + 3y^2 = 24; (6, -2)$   
A) Yes                                      B) No

Answer: A

- 39)  $y = \sqrt{x - 1}; (50, 7)$   
A) Yes                                      B) No

Answer: A

- 40)  $y = \frac{9}{x}; \left(4, \frac{4}{9}\right)$   
A) Yes                                      B) No

Answer: B

41)  $y^2 = 2x$ ;  $(5, \sqrt{10})$

A) Yes

Answer: A

B) No

Write the x- and y-intercepts of the graph.

42)

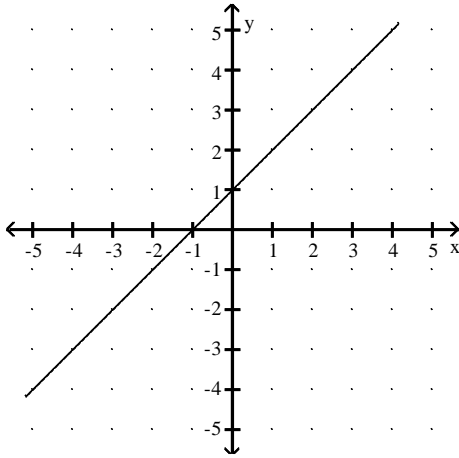

A) x-intercept: 1; y-intercept: -1

C) x-intercept: -1; y-intercept: 1

Answer: C

B) x-intercept: -1; y-intercept: -1

D) x-intercept: 1; y-intercept: 1

43)

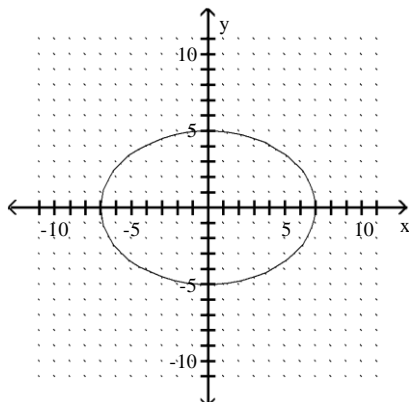

A) y-intercepts: 5, -5

5

C) x-intercepts: 7, -7

Answer: B

B) x-intercepts: 7, -7; y-intercepts: 5, -5

D) x-intercepts: 5, -5; y-intercepts: 7, -7

44)

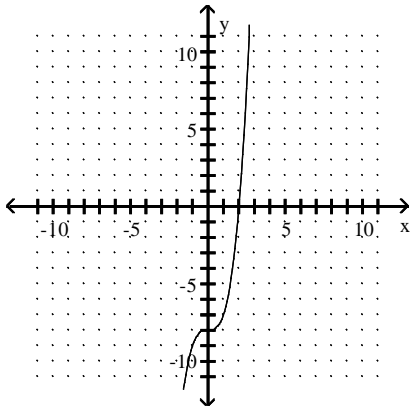

- A) x-intercept: 2; y-intercept: 8
- C) x-intercept: 2; y-intercept: -8

- B) x-intercept: -2; y-intercept: 8
- D) x-intercept: -2; y-intercept: -8

Answer: C

45)

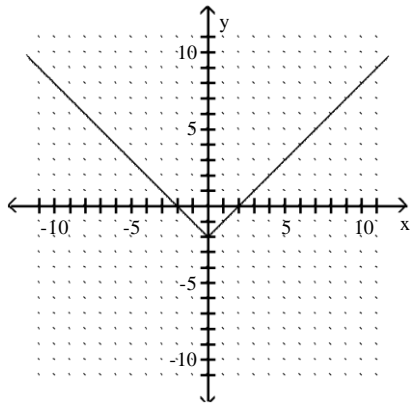

- A) x-intercepts: 2, -2; y-intercept: 0
- C) y-intercept: -2

- B) x-intercepts: 2, -2; y-intercept: -2
- D) x-intercepts: 2, -2

Answer: B

Graph the equation by plotting points.

46)  $y = x + 1$

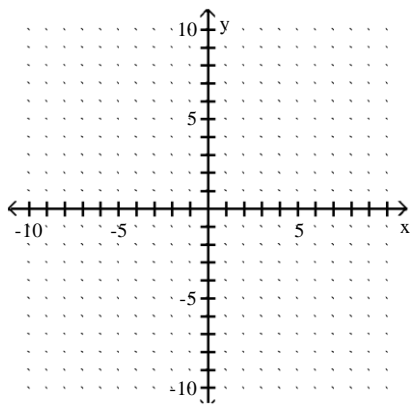



A)

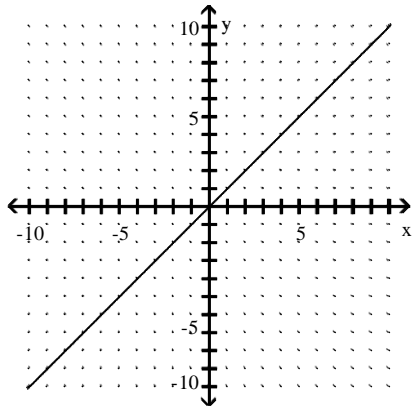

B)

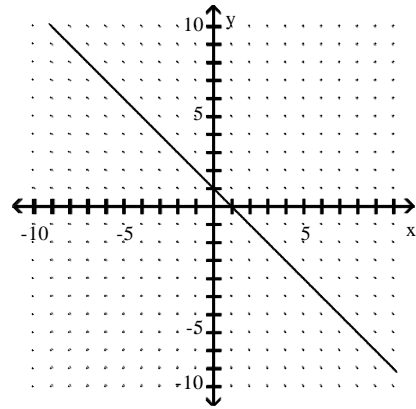

C)

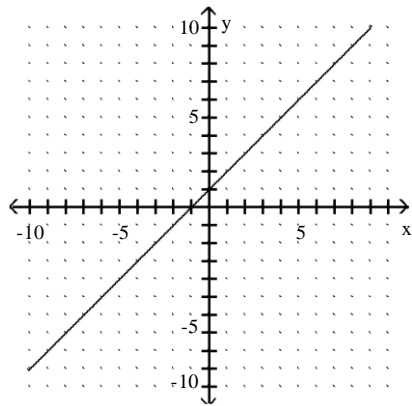

D)

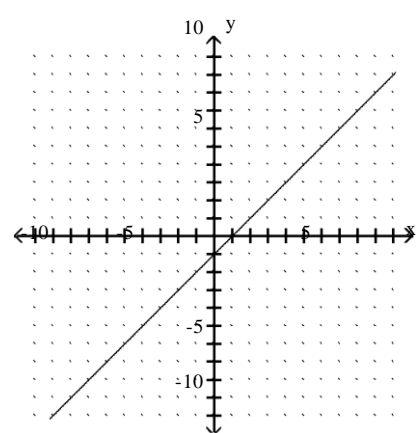

Answer: C

47)  $y = \frac{4}{3}x - 2$

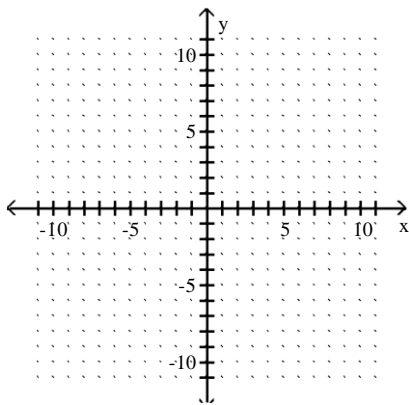

A)

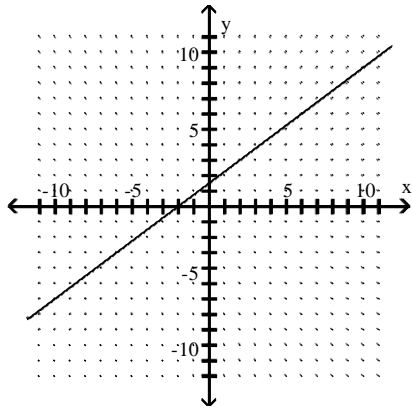

B)

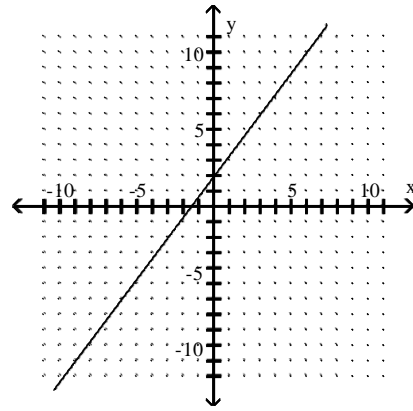

C)

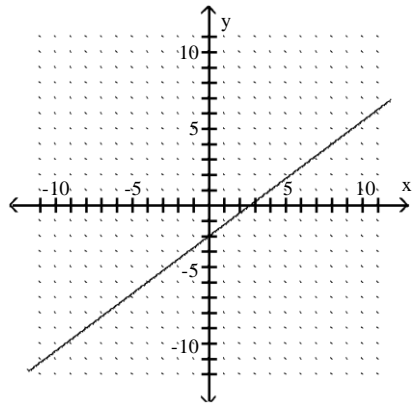

D)

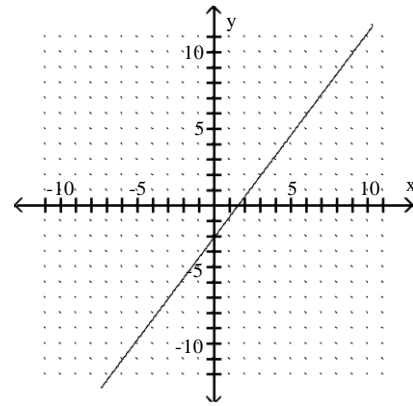

Answer: D

48)  $y = 2x + 4$

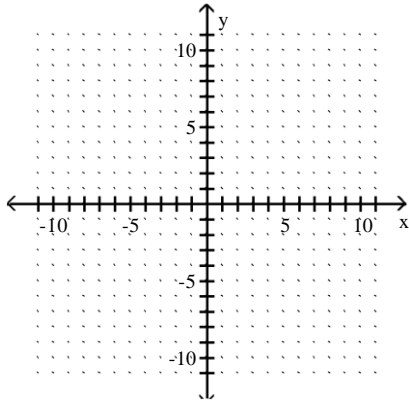

A)

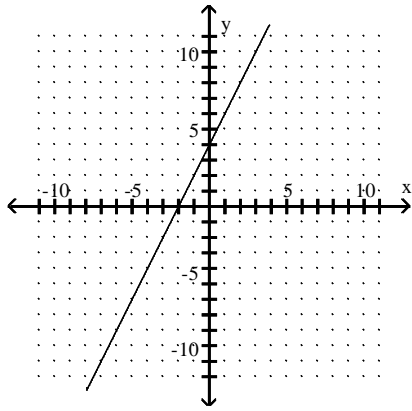

B)

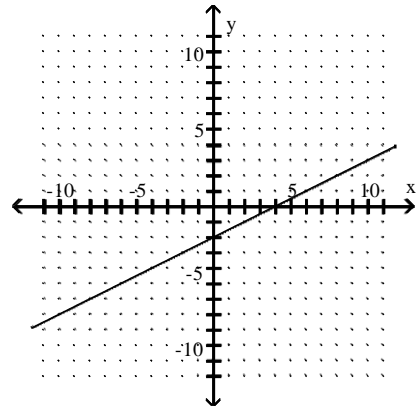

C)

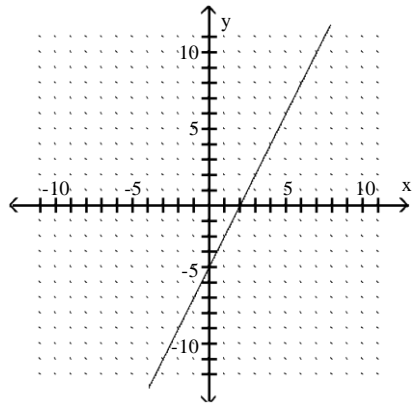

D)

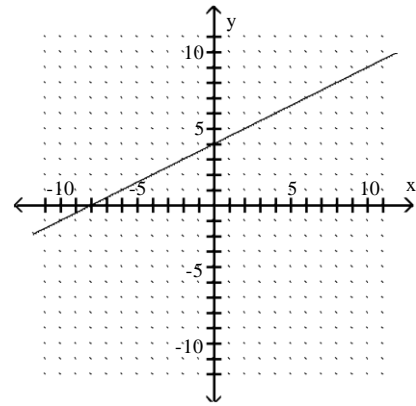

Answer: A

49)  $y = |x| - 2$

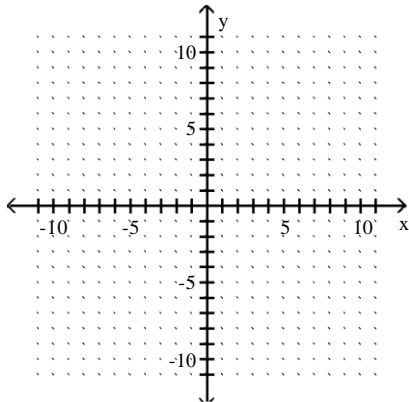

A)

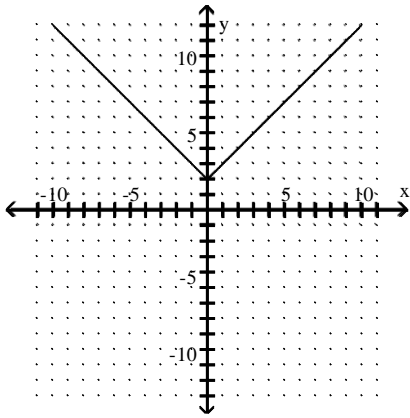

B)

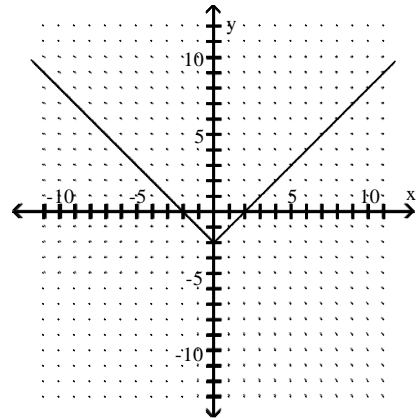

C)

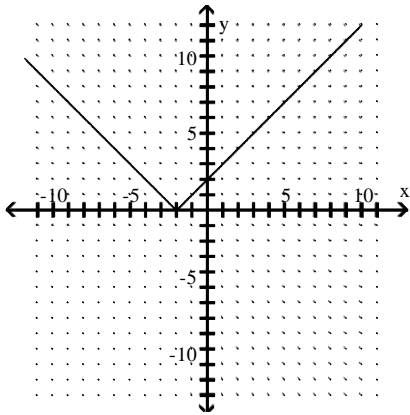

D)

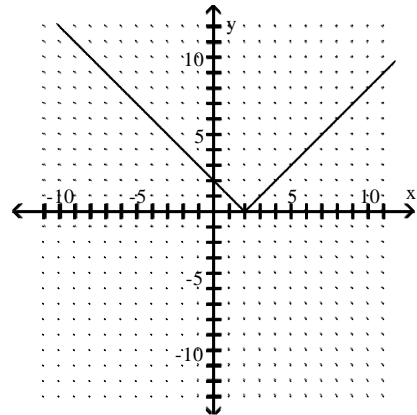

Answer: B

50)  $y = |-1 - x|$

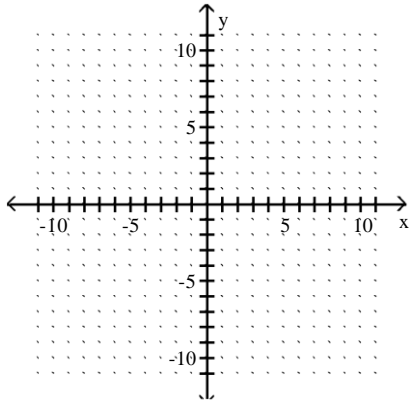

A)

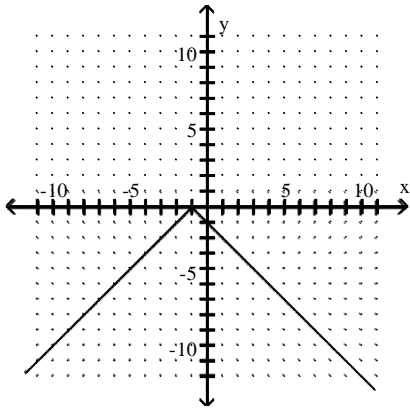

B)

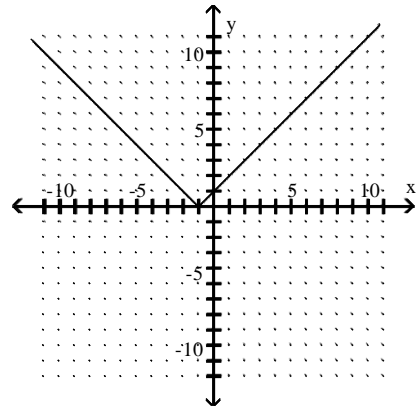

C)

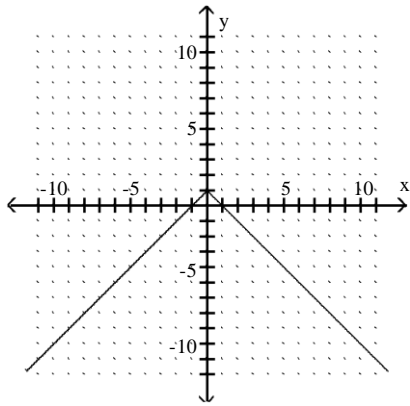

D)

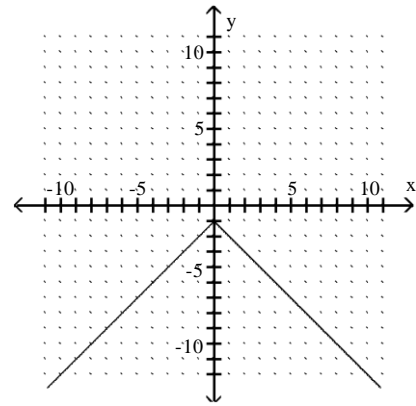

Answer: B

51)  $y = x^2 - 5$

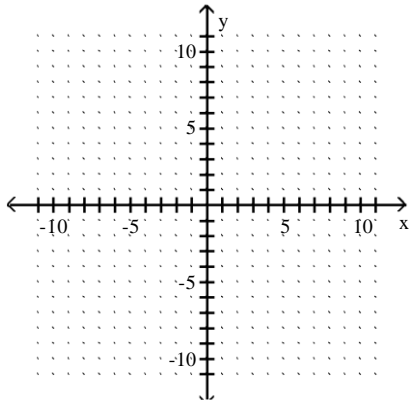

A)

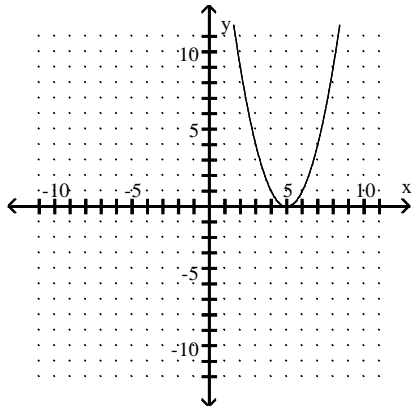

B)

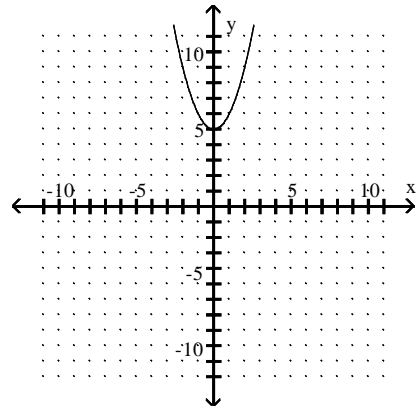

C)

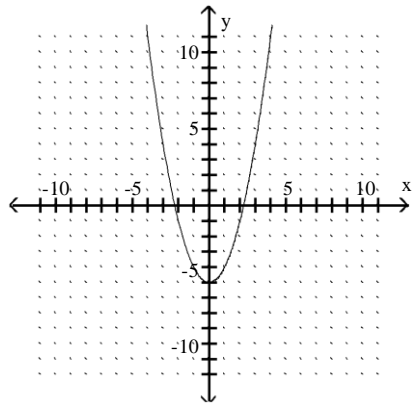

D)

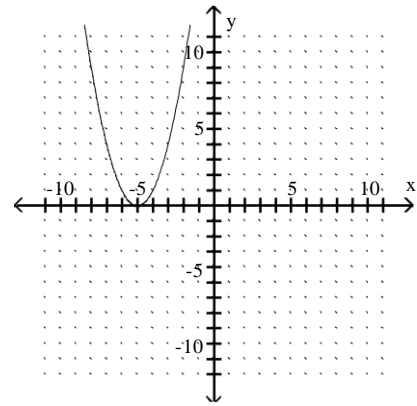

Answer: C

52)  $y = -x^2 - 3$

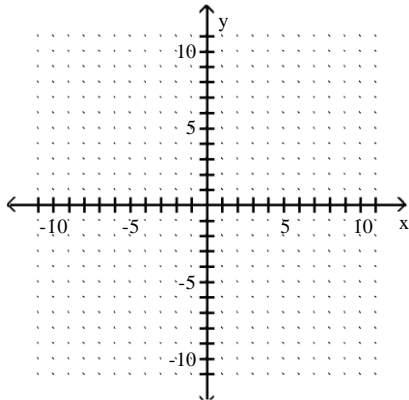

A)

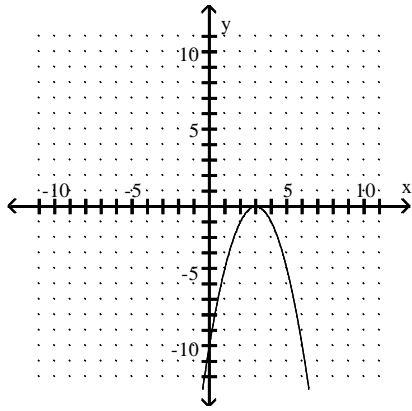

B)

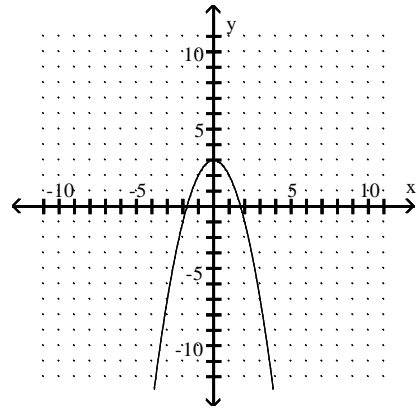

C)

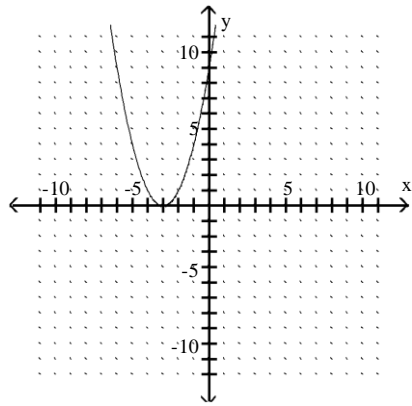

D)

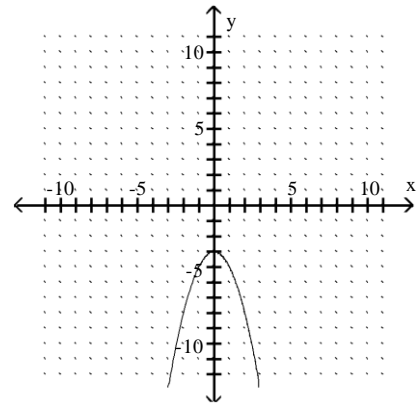

Answer: D

53)  $y = x^3 + 4$

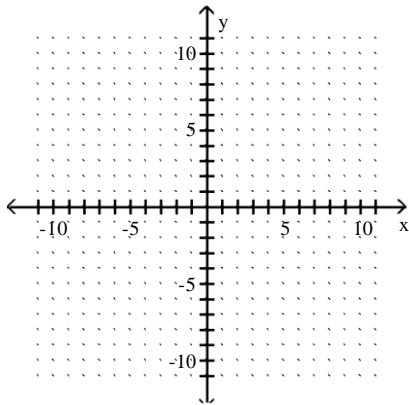

A)

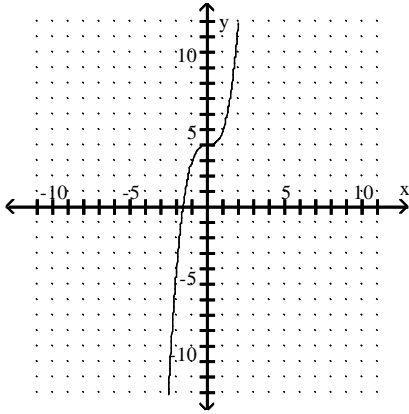

B)

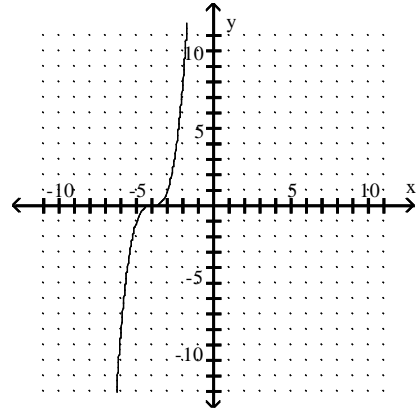

C)

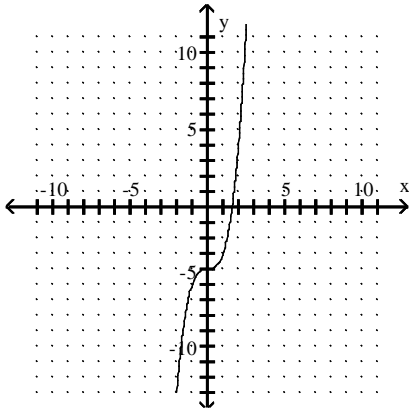

D)

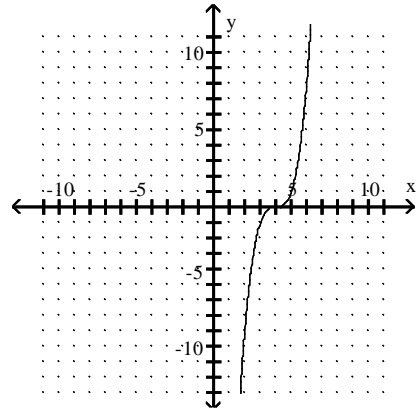

Answer: A

54)  $y = \sqrt{x+6}$

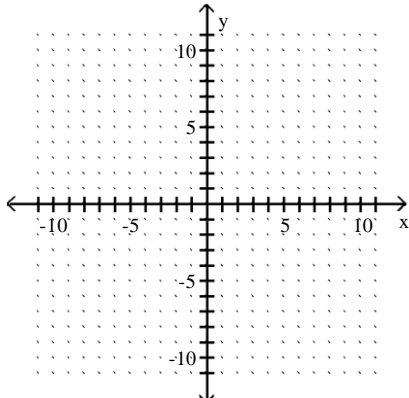



A)

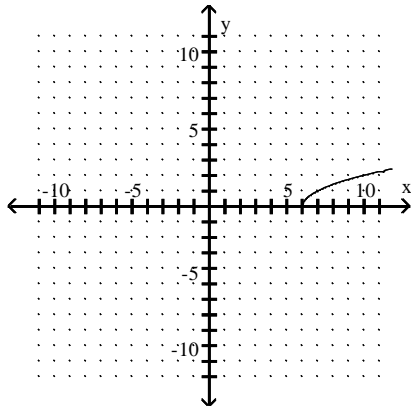

B)

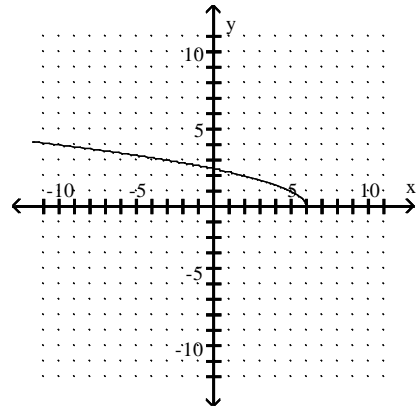

C)

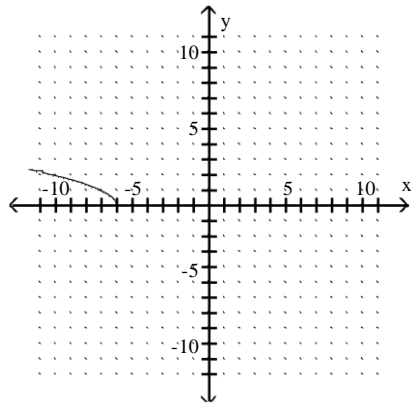

D)

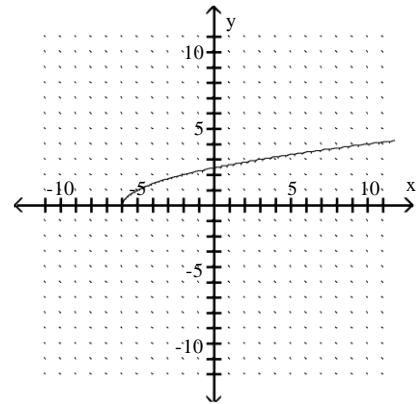

Answer: D

Find the x- and y-intercepts of the graph of the equation.

55)  $10y - 2x = -6$

A) x-intercept:  $\frac{3}{5}$ ; y-intercept: 3

B) x-intercept: -3; y-intercept:  $\frac{3}{5}$

C) x-intercept:  $\frac{3}{5}$ ; y-intercept: -3

D) x-intercept: 3; y-intercept:  $-\frac{3}{5}$

Answer: D

56)  $5x - 10y = 20$

A) x-intercept: -2; y-intercept: 4

B) x-intercept: 4; y-intercept: -2

C) x-intercept: -4; y-intercept: 2

D) x-intercept: 2; y-intercept: -4

Answer: B

57)  $9x^2 + y^2 = 9$

A) x-intercepts: -1, 1; y-intercepts: -9, 9

B) x-intercepts: -3, 3; y-intercepts: -1, 1

C) x-intercepts: -9, 9; y-intercepts: -1, 1

D) x-intercepts: -1, 1; y-intercepts: -3, 3

Answer: D

58)  $y = x^2 + 14x + 48$

A) x-intercepts: 6, 8; y-intercept: 48

B) x-intercept: 48; y-intercepts: -6, -8

C) x-intercept: 48; y-intercepts: 6, 8

D) x-intercepts: -6, -8; y-intercept: 48

Answer: D

59)  $\frac{x}{3} + \frac{y}{4} = 3$

- A) x-intercept: 12; y-intercept: 9  
 C) x-intercept: 6; y-intercept: 7

- B) x-intercept: 9; y-intercept: 12  
 D) x-intercept: 4; y-intercept: 3

Answer: B

60)  $x = y^2 - 10y + 24$

- A) x-intercepts: -6, -4; y-intercept: -24  
 C) x-intercepts: 6, 4; y-intercept: 24

- B) x-intercept: -24; y-intercepts: -6, -4  
 D) x-intercept: 24; y-intercepts: 6, 4

Answer: D

61)  $y = \sqrt{16 - x^2}$

- A) x-intercept: 4; y-intercepts: -4, 4  
 C) x-intercepts: -4, 4; y-intercept: 4

- B) x-intercept: 4; y-intercept: -4  
 D) x-intercept: 4; y-intercept: 4

Answer: C

Test the equation for symmetry with respect to the x-axis, the y-axis, and the origin.

62)  $y = 3x^2 + 1$

- A) y-axis only  
 C) x-axis, y-axis, origin

- B) x-axis only  
 D) origin only

Answer: A

63)  $2x = 5y^2 - 3$

- A) y-axis only  
 C) x-axis, y-axis, origin

- B) origin only  
 D) x-axis only

Answer: D

64)  $y = -6x^3 + 9x$

- A) x-axis only  
 origin

B) origin only

C) x-axis, y-axis

D) x-axis,

Answer: B

65)  $y = 9x^5 + 9x^3$

- A) x-axis, y-axis, origin  
 C) no symmetry

- B) origin only  
 D) y-axis only

Answer: B

66)  $y = 5x^4 - 3x + 5$

- A) origin only  
 symmetry

B) x-axis only

C) x-axis, origin

D) no

Answer: D

Specify the center and radius of the circle.

67)  $(x + 5)^2 + (y + 8)^2 = 9$

- A) center: (-5, -8); radius: 3  
 C) center: (5, 8); radius: 3

- B) center: (8, 5); radius: 9  
 D) center: (-8, -5); radius: 9

Answer: A

68)  $(x - 2)^2 + (y + 7)^2 = 16$

A) center: (-2, 7); radius: 16

C) center: (7, -2); radius: 16

Answer: D

B) center: (-7, 2); radius: 4

D) center: (2, -7); radius: 4

69)  $(x - 2)^2 + (y - 5)^2 = 6$

A) center: (2, 5); radius:  $\sqrt{6}$

C) center: (-2, -5); radius: 6

Answer: A

B) center: (-2, -5); radius:  $\sqrt{6}$

D) center: (2, 5); radius: 6

70)  $x^2 + y^2 - 10x - 18y + 102 = 0$

A) center: (5, 9); radius: 2

C) center: (9, 5); radius: 2

Answer: A

B) center: (-5, -9); radius: 4

D) center: (-9, -5); radius: 4

71)  $x^2 - 14x + y^2 - 10y + 25 = 0$

A) center: (-7, -5); radius: 49

C) center: (-7, -5); radius: 7

Answer: D

B) center: (7, 5); radius: 49

D) center: (7, 5); radius: 7

72)  $3x^2 + 3y^2 + 18x + 30y + 75 = 0$

A) center: (-5, -3); radius: 3

C) center: (5, 3); radius: 9

Answer: D

B) center: (3, 5); radius: 9

D) center: (-3, -5); radius: 3

Find the standard form of the equation of a circle that satisfies the given conditions.

73) Center at (6, 0); radius 4

A)  $(x + 6)^2 + y^2 = 16$

B)  $x^2 + (y + 6)^2 = 4$

C)  $(x - 6)^2 + y^2 = 16$

D)  $x^2 + (y - 6)^2 = 4$

Answer: C

74) Center at (0, -8); radius 8

A)  $(x - 8)^2 + y^2 = 64$

B)  $x^2 + (y - 8)^2 = 8$

C)  $x^2 + (y + 8)^2 = 64$

D)  $(x + 8)^2 + y^2 = 64$

64

Answer: C

75) Center at (4, 9); radius  $\sqrt{14}$

A)  $(x + 4)^2 + (y + 9)^2 = 14$

C)  $(x - 9)^2 + (y - 4)^2 = 196$

Answer: D

B)  $(x + 9)^2 + (y + 4)^2 = 196$

D)  $(x - 4)^2 + (y - 9)^2 = 14$

76) Center (6, -1); passing through the point (9, 3)

A)  $(x - 1)^2 + (y + 6)^2 = 9$

C)  $(x + 6)^2 + (y - 1)^2 = 25$

Answer: D

B)  $(x + 1)^2 + (y - 6)^2 = 9$

D)  $(x - 6)^2 + (y + 1)^2 = 25$

77) Center (15, 7); containing the origin

A)  $(x - 7)^2 + (y - 15)^2 = 274$

C)  $(x - 7)^2 + (y - 15)^2 = 17$

Answer: B

B)  $(x - 15)^2 + (y - 7)^2 = 274$

D)  $(x - 15)^2 + (y - 7)^2 = 17$

78) Center (18, 20); touching the x-axis

A)  $(x - 20)^2 + (y - 18)^2 = 324$

C)  $(x - 18)^2 + (y - 20)^2 = 324$

Answer: B

B)  $(x - 18)^2 + (y - 20)^2 = 400$

D)  $(x - 20)^2 + (y - 18)^2 = 20$

79) Center (19, 20); touching the y-axis

A)  $(x - 20)^2 + (y - 19)^2 = 19$

C)  $(x - 19)^2 + (y - 20)^2 = 19$

Answer: D

B)  $(x - 20)^2 + (y - 19)^2 = 361$

D)  $(x - 19)^2 + (y - 20)^2 = 361$

80) Diameter with endpoints (-2, -4) and (-2, 4)

A)  $(x + 2)^2 + y^2 = 4$

B)  $(x + 2)^2 + y^2 = 16$

C)  $(x + 4)^2 + y^2 = 4$

D)  $x^2 + (y + 4)^2 =$

4

Answer: B

81) Diameter with endpoints (-9, 6) and (-1, -4)

A)  $(x + 5)^2 + y^2 = 25$

C)  $(x + 5)^2 + (y - 1)^2 = 41$

B)  $x^2 + (y - 1)^2 = 16$

D)  $(x - 1)^2 + (y + 5)^2 = 41$

Answer: C

Graph the circle.

82)  $x^2 + y^2 = 25$

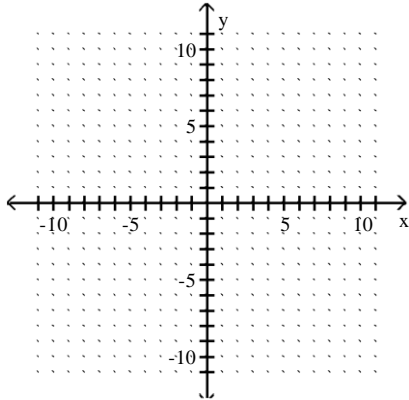

A)

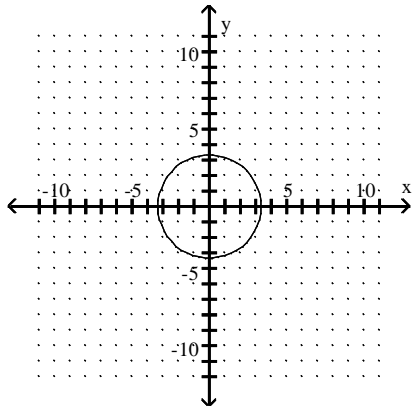

B)

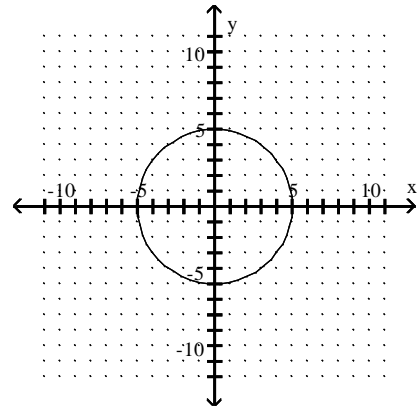

C)

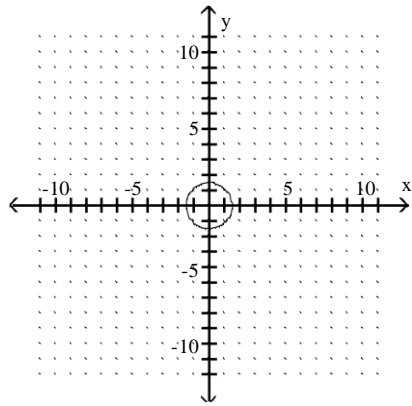

D)

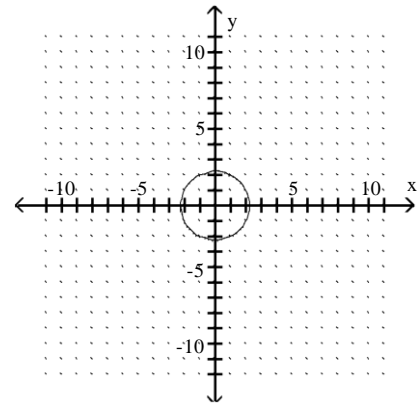

Answer: B

83)  $(x - 6)^2 + (y - 4)^2 = 16$

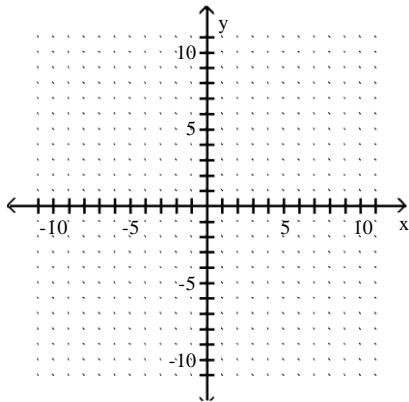

A)

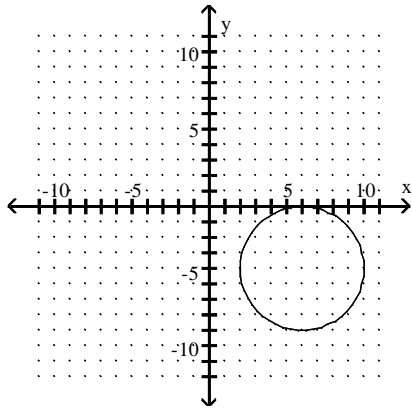

B)

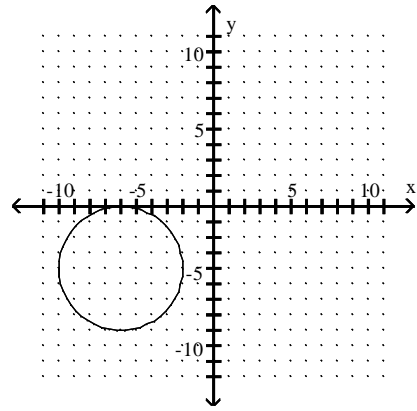

C)

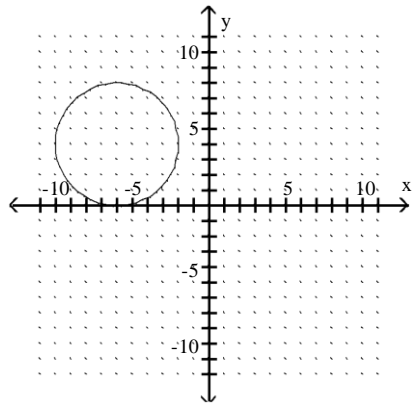

D)

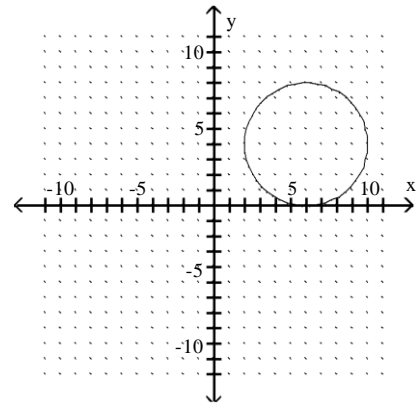

Answer: D

84)  $x^2 + (y - 3)^2 = 36$

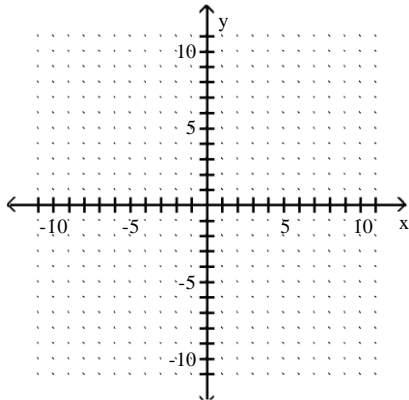

A)

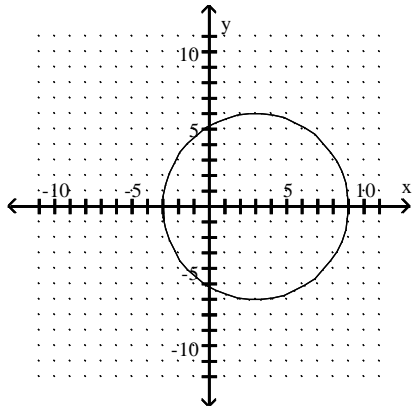

B)

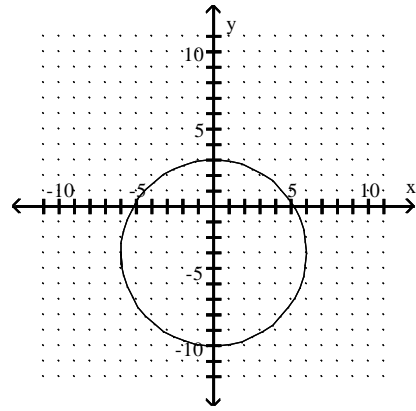

C)

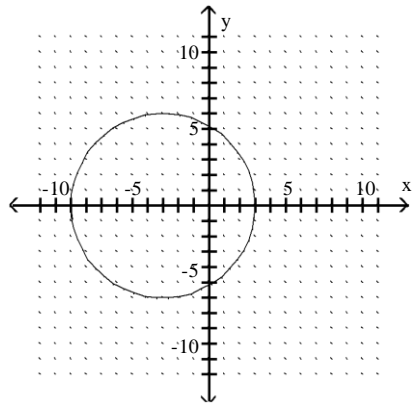

D)

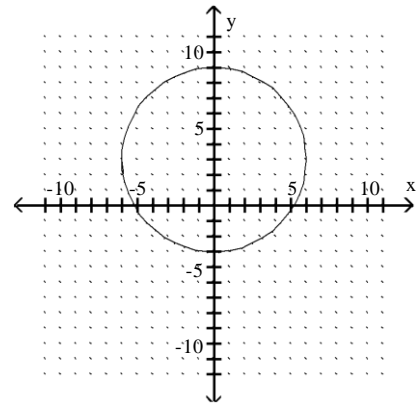

Answer: D

85)  $(x - 3)^2 + (y + 1)^2 = 4$

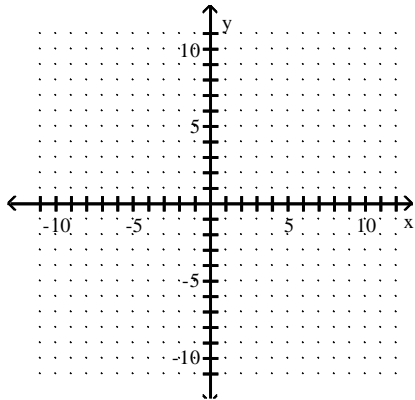

A)

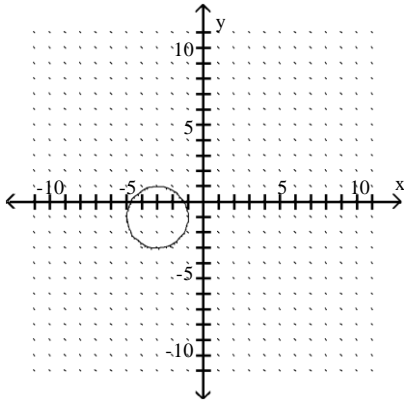

B)

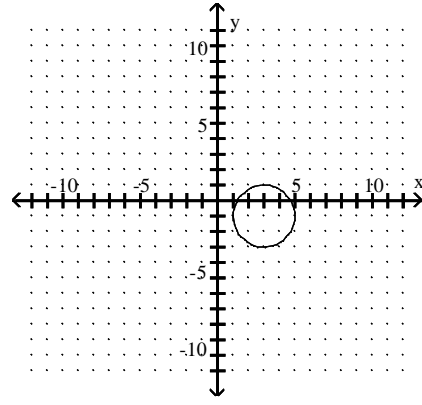

C)

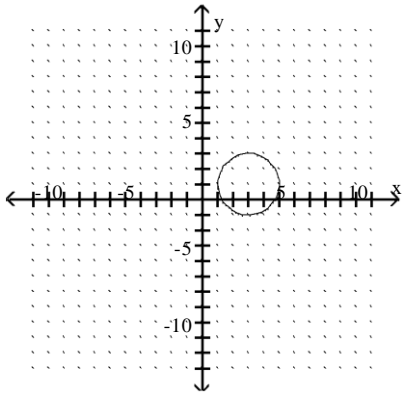

D)

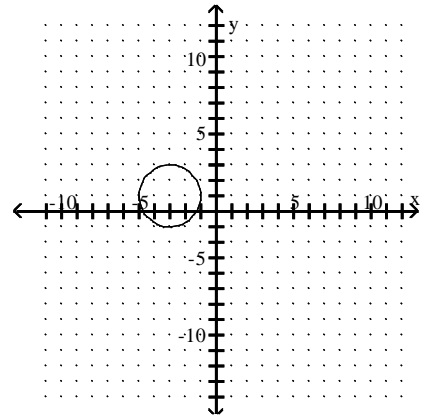

Answer: B

86)  $(x - 3)^2 + y^2 = 4$

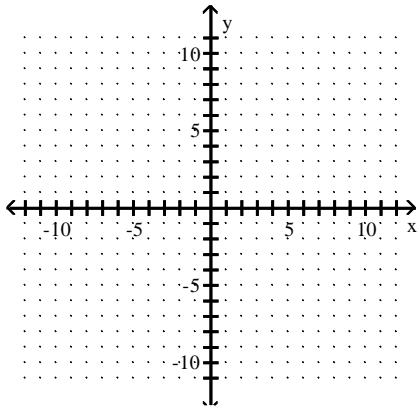



A)

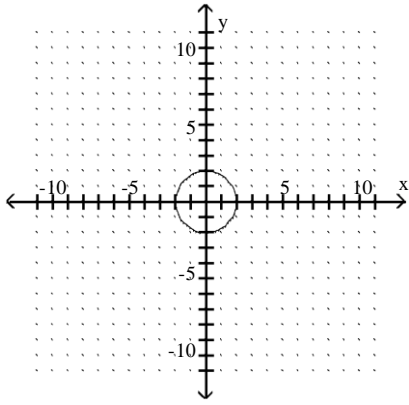

B)

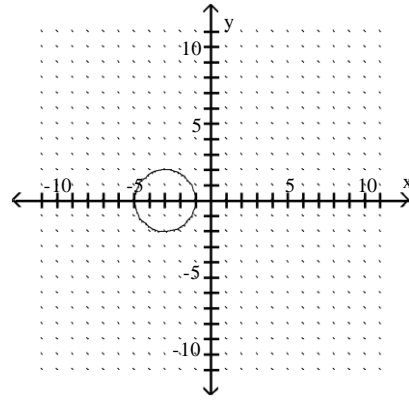

C)

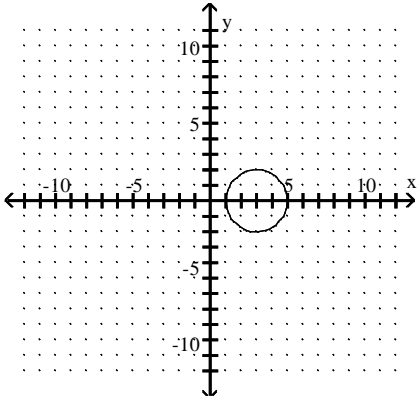

D)

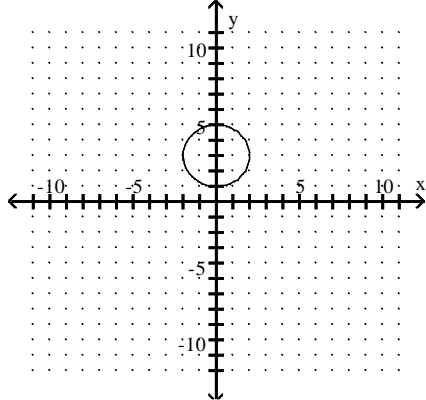

Answer: C

87)  $x^2 + y^2 - 8x - 10y + 37 = 0$

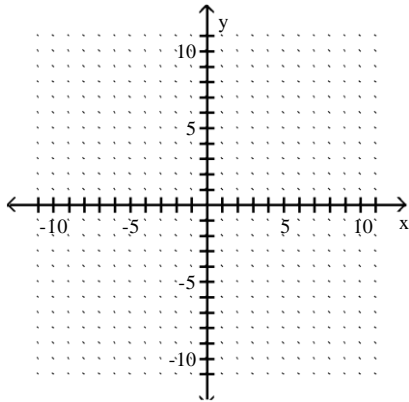

A)

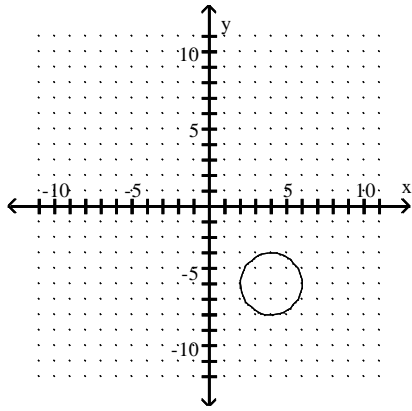

B)

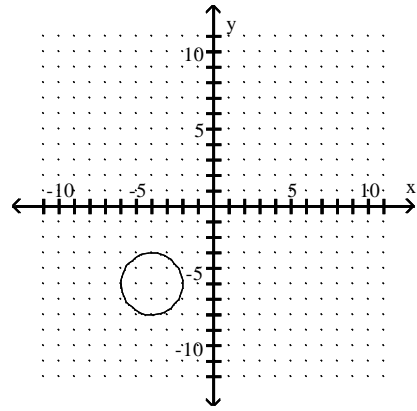

C)

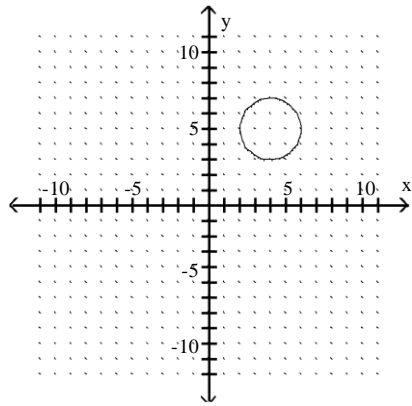

D)

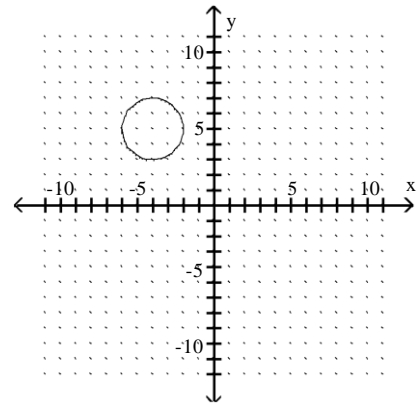

Answer: C

88)  $x^2 + y^2 + 6x + 8y + 0 = 0$

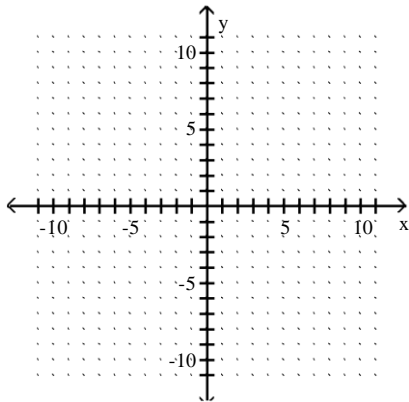

A)

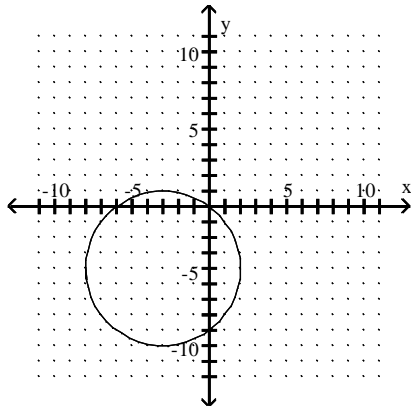

B)

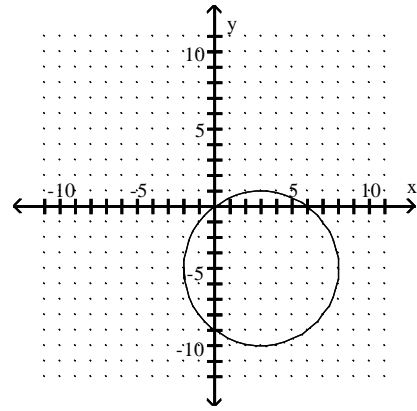

C)

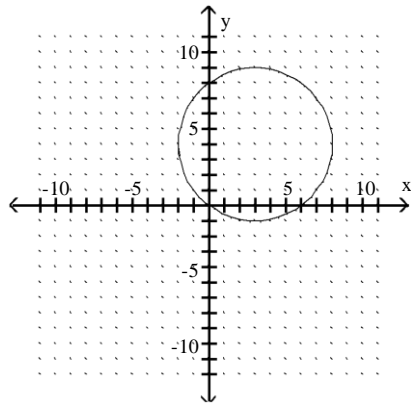

D)

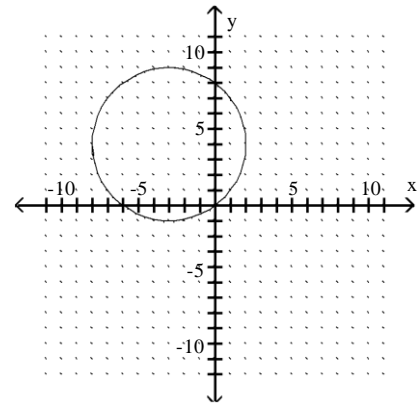

Answer: A

Find: a. The center and radius of the circle. b. The x- and y-intercepts of the graph of the circle.

89)  $x^2 + y^2 + 2x - 2y - 5 = 0$

A) a. center =  $(-1, 1)$ ; radius =  $\sqrt{7}$

b.  $(-1 + \sqrt{6}, 0)$ ,  $(-1 - \sqrt{6}, 0)$ ,  $(0, 1 + \sqrt{6})$ ,  $(0, 1 - \sqrt{6})$

6) B) a. center =  $(-1, -1)$ ; radius =  $\sqrt{7}$

b.  $(-1 + 2\sqrt{2}, 0)$ ,  $(-1 - 2\sqrt{2}, 0)$ ,  $(0, 1 + \sqrt{6})$ ,  $(0, 1 - \sqrt{6})$

C) a. center =  $(-1, 1)$ ; radius =  $\sqrt{7}$

7 b.  $(-1 + \sqrt{6}, 0)$ ,  $(0, 1 + \sqrt{6})$

D) a. center =  $(1, -1)$ ; radius =  $\sqrt{7}$

b.  $(-1 + \sqrt{6}, 0)$ ,  $(-1 - \sqrt{6}, 0)$ ,  $(0, 1 + \sqrt{6})$ ,  $(0, 1 - \sqrt{6})$

6) Answer: A

90)  $x^2 + y^2 - 2x + 2y - 10 = 0$

A) a. center = (-1, 1); radius = 12

b.  $(1 + \sqrt{11}, 0), (0, -1 + \sqrt{11})$

B) a. center = (1, -1); radius =  $\frac{\sqrt{2}}{3}$

b.  $(1 + \sqrt{11}, 0), (1 - \sqrt{11}, 0), (0, -1 + \sqrt{11}), (0, -1 - \sqrt{11})$

11) C) a. center = (-1, -1); radius =  $\frac{2}{3}$

b.  $(1 + \sqrt{11}, 0), (0, -1 + \sqrt{11})$

D) a. center = (1, -1); radius =  $\frac{\sqrt{2}}{3}$

b.  $(-1 + \sqrt{11}, 0), (-1 - \sqrt{11}, 0), (0, 1 + \sqrt{11}), (0, 1 - \sqrt{11})$

Answer: B

91)  $x^2 + y^2 - 2y - 8 = 0$

A) a. center = (0, -1); radius = 9

b.  $(2\sqrt{2}, 0), (0, 4), (0, -2)$

C) a. center = (0, 1); radius = 3

b.  $(2\sqrt{2}, 0), (-2\sqrt{2}, 0), (0, 4), (0, -2)$

2) Answer: C

92)  $4x^2 - 16x + 4y^2 - 48 = 0$

A) a. center = (-2, 0); radius = 4

b.  $(6, 0), (-2, 0), (0, 4\sqrt{3}), (0, -4\sqrt{3})$

3) C) a. center = (2, 0); radius = 16

b.  $(6, 0), (-2, 0), (0, 4\sqrt{3}), (0, -4\sqrt{3})$

Answer: D

93)  $3x^2 + 3y^2 - 2y = 0$

A) a. center =  $\left(0, \frac{1}{3}\right)$ ; radius =  $\frac{1}{9}$

b.  $\left(0, \frac{2}{3}\right)$

C) a. center =  $\left(0, \frac{1}{3}\right)$ ; radius =  $\frac{1}{3}$

b. (0, 0)

Answer: D

94)  $x^2 + y^2 + 4 = 0$

A) a. center = (0, 0); radius = 2

b. (2, 0), (0, 2)

C) a. center = (0, 0); radius = 2

B) a. center = (0, 1); radius = 3

b.  $(\sqrt{2}, 0), (0, 4)$

D) a. center = (1, 0); radius = 9

b.  $(2\sqrt{2}, 0), (-2\sqrt{2}, 0), (0, 4), (0, -2)$

B) a. center = (-2, 0); radius = 16

b.  $(6, 0), (0, 4\sqrt{3})$

D) a. center = (2, 0); radius = 4

b.  $(6, 0), (-2, 0), (0, 4\sqrt{3}), (0, -4\sqrt{3})$

B) a. center =  $\left(0, \frac{1}{3}\right)$ ; radius =  $\frac{1}{3}$

b.  $(0, 0), \left(0, \frac{2}{3}\right)$

D) a. center =  $\left(0, \frac{1}{3}\right)$ ; radius =  $\frac{1}{3}$

b.  $(0, 0), \left(0, \frac{2}{3}\right)$

b. (-2, 0), (2, 0), (0, 2), (0, -2)

Answer: B

B) a.  $\emptyset$

b.  $\emptyset$

D) a. center =  $(0, 0)$ ; radius  
= 4 b.  $(-2, 0), (2, 0), (0, 2), (0, -2)$

Solve for the requested variable.

- 95) The equation  $E = 0.0057x^3 - 0.0044x^2 + 0.175x + 1.53$  gives the approximate total earnings of a company, in millions of dollars, where  $x = 0$  corresponds to 1996. Determine the earnings for 1998.  
A) \$1.71 million      B) \$1.91 million      C) \$1.94 million      D) \$2.17 million

Answer: B

- 96) Your company uses the quadratic model  $y = -11x^2 + 350x$  to represent how many units ( $y$ ) of a new product will be sold ( $x$ ) weeks after its release. How many units can you expect to sell in week 9?  
A) 4041 units      B) 3249 units      C) 2259 units      D) 3051 units

Answer: C

- 97) Your company uses the quadratic model  $y = -4.5x^2 + 150x$  to represent the average number of new customers who will be signed on ( $x$ ) weeks after the release of your new service. How many new customers can you expect to gain in week 28?  
A) 4074 customers      B) 672 customers      C) 336 customers      D) -1428 customers

Answer: B

Find the slope of the line through the given pair of points.

- 98) (6, 5) and (7, 1)  
A) 4      B)  $-\frac{1}{4}$       C) -4      D)  $\frac{6}{13}$

Answer: C

- 99) (1, -7) and (6, -1)  
A)  $-\frac{8}{7}$       B)  $\frac{5}{6}$       C)  $-\frac{6}{5}$       D)  $\frac{6}{5}$

Answer: D

- 100) (-7, 15) and (16, -16)  
A)  $-\frac{31}{23}$       B)  $\frac{31}{23}$       C)  $-\frac{1}{9}$       D)  $-\frac{23}{31}$

Answer: A

- 101) (4, 2) and (4, 3)  
A)  $-\frac{1}{8}$       B) 0      C)  $\frac{5}{8}$       D) undefined

Answer: D

- 102) (-6, 7), (9, 7)  
A) -15      B) 15      C) 0      D) 0

Answer: C

- 103)  $(\sqrt{3}, -1)$  and  $(0.45, -1)$   
A)  $0.45 - \sqrt{3}$       B) 0      C)  $\sqrt{3} - 0.45$       D) undefined

Answer: B

104)  $(19.5, 16.9), (9.9, 9.2)$

A)  $-\frac{96}{77}$

B)  $\frac{96}{77}$

C)  $\frac{77}{96}$

D)  $-\frac{77}{96}$

Answer: C

Find the slope of the line.

105)

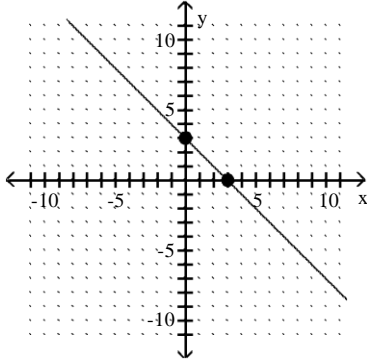

A) 3

B) 1

C) -3

D) -1

Answer: D

106)

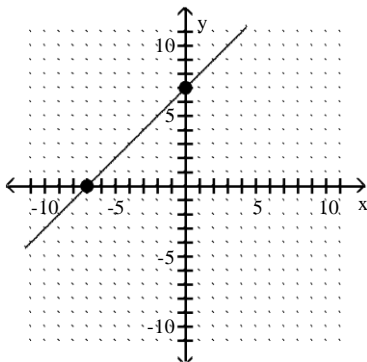

A) -1

B) 1

C) -7

D) 7

Answer: B

107)

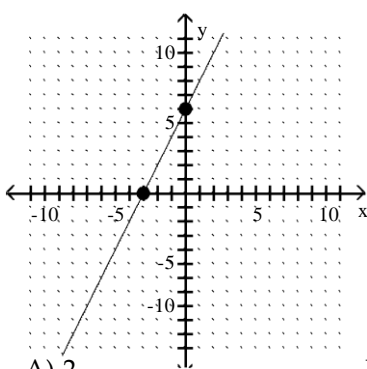

A) 2

B)  $-\frac{1}{2}$

C) -2

D)  $\frac{1}{2}$

Answer: A

108)

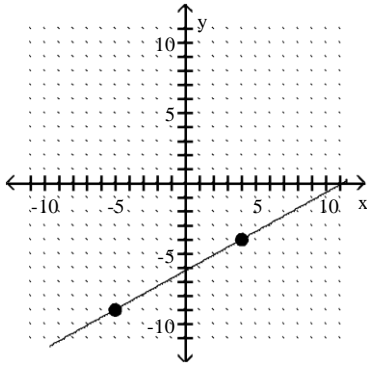

A)  $-\frac{9}{5}$

B)  $\frac{9}{5}$

C)  $-\frac{5}{9}$

D)  $\frac{5}{9}$

Answer: D

109)

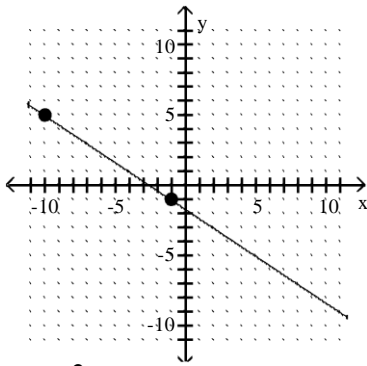

A)  $\frac{2}{3}$

B)  $\frac{3}{2}$

C)  $-\frac{2}{3}$

D)  $-\frac{3}{2}$

Answer: C

110)

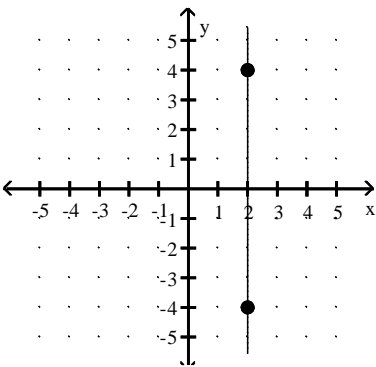

A) 8

B) -8

C) 0

D) undefined

Answer: D



111)

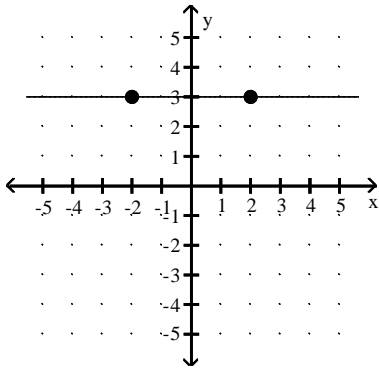

A) -4

B) 4

C) 0

D) undefined

Answer: C

Find an equation in slope-intercept form of the line that passes through the given point and has slope  $m$ .

112)  $(0, 6)$ ;  $m = \frac{4}{3}$

A)  $y = 6x + \frac{4}{3}$

B)  $y = 6x - \frac{4}{3}$

C)  $y = \frac{4}{3}x - 6$

D)  $y = \frac{4}{3}x + 6$

Answer: D

113)  $(0, 4)$ ;  $m = -\frac{5}{7}$

A)  $y = -\frac{5}{7}x + 4$

B)  $y = 4x +$

C)  $y = -\frac{5}{7}x - 4$

D)  $y = 4x - \frac{5}{7}$

Answer: A

114)  $(0, 3)$ ;  $m = \frac{3}{4}$

A)  $y = 3x - \frac{3}{4}$

B)  $y = \frac{3}{4}x - 3$

C)  $y = \frac{3}{4}x + 3$

D)  $y = 3x + \frac{3}{4}$

Answer: C

115)  $(-6, 0)$ ;  $m = -5$

A)  $y = -6x - 5$

B)  $y = -5x - 30$

C)  $y = 5x - 6$

D)  $y = 6x - 5$

Answer: B

116)  $(4, 4)$ ;  $m = -\frac{3}{5}$

A)  $y = -\frac{3}{5}x + \frac{32}{5}$

B)  $y = -\frac{3}{5}x - \frac{32}{5}$

C)  $y = -\frac{3}{5}x + 5$

D)  $y = -\frac{3}{5}x + \frac{5}{32}$

Answer: C

117)  $(5, 2)$ ;  $m = -\frac{3}{4}$

A)  $y = -\frac{3}{4}x + \frac{23}{4}$

B)  $y = -\frac{3}{4}x - \frac{23}{4}$

C)  $y = -\frac{4}{3}x - \frac{4}{23}$

D)  $y = -\frac{3}{4}x + \frac{4}{23}$

Answer: A

118)  $(9, -3); m = -\frac{3}{4}$

A)  $y = -\frac{3}{4}x + 6$

B)  $y = -\frac{3}{4}x + 4$

C)  $y = \frac{3}{4}x - 4$

D)  $y = -\frac{3}{4}x + \frac{15}{4}$

Answer: D

119)  $(4, 8); m = 0$

A)  $y = -\frac{1}{2}x + 0$

B)  $y = 8$

C)  $y = -2x + 0$

D)  $x = 4$

Answer: B

120)  $(7, 6); m$  is undefined

A)  $y = 6$

B)  $x = 6$

C)  $y = 7$

D)  $x = 7$

Answer: D

Sketch the graph of the line by locating the second point with the rise-and-run method.

121) Through  $(0, 2), m = \frac{1}{3}$

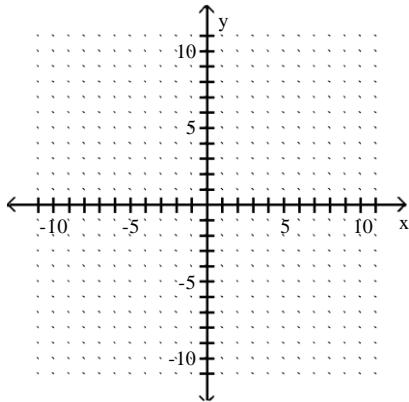

A)

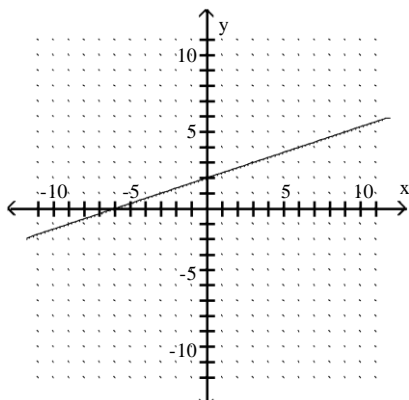

B)

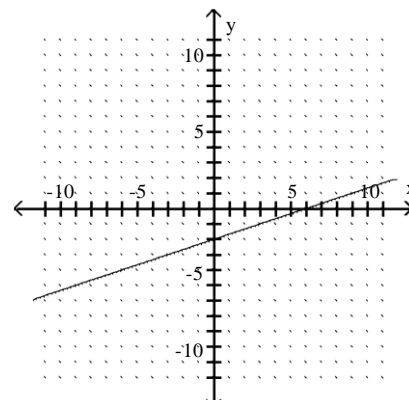

C)

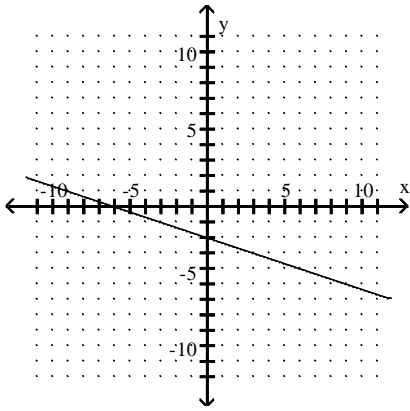

D)

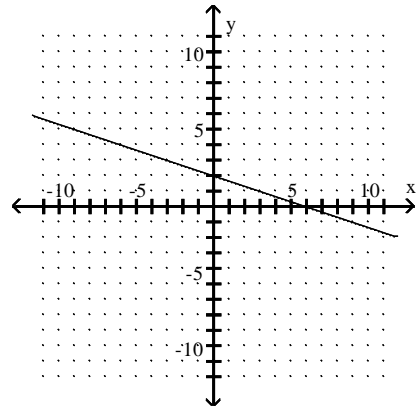

Answer: A

122) Through  $(0, 6)$ ,  $m = -6$

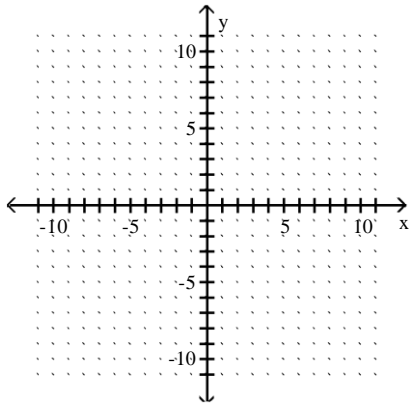

A)

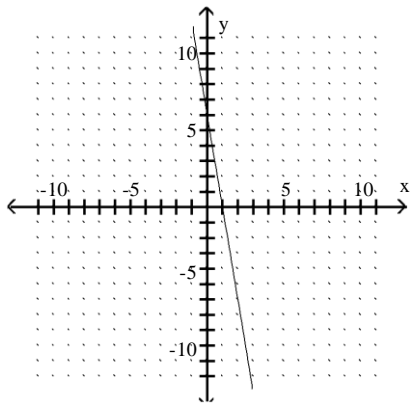

B)

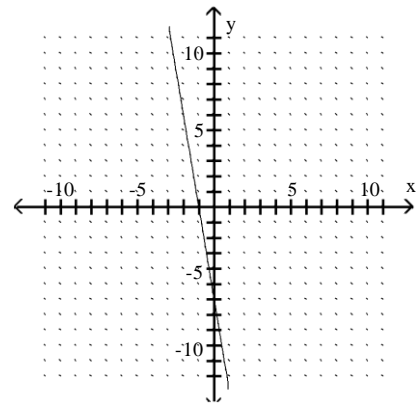

C)

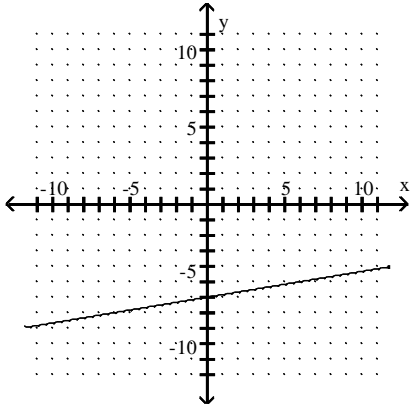

D)

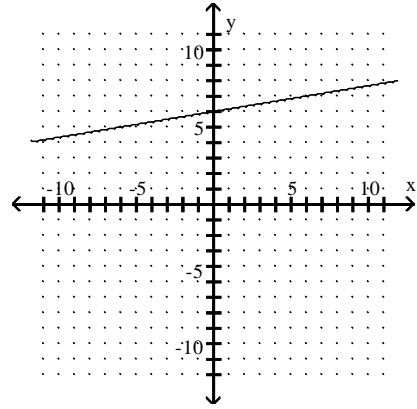

Answer: A

123) Through  $(9, 0)$ ,  $m = -\frac{1}{3}$

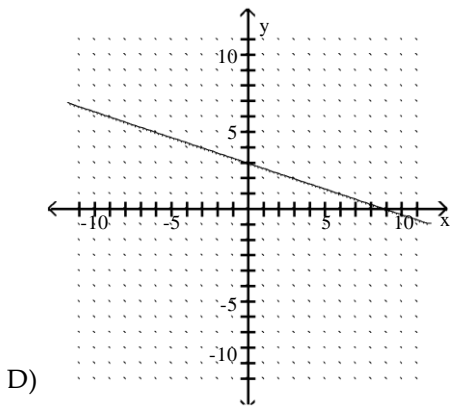
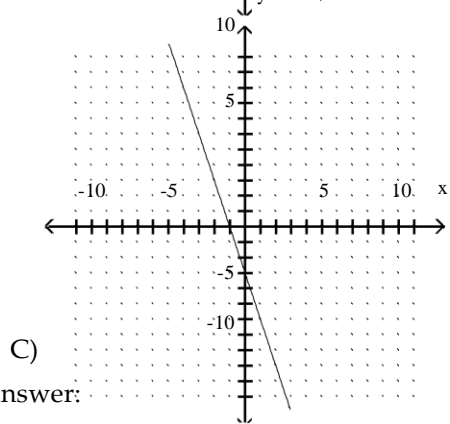
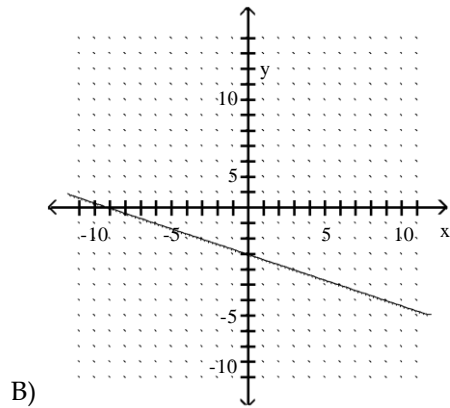
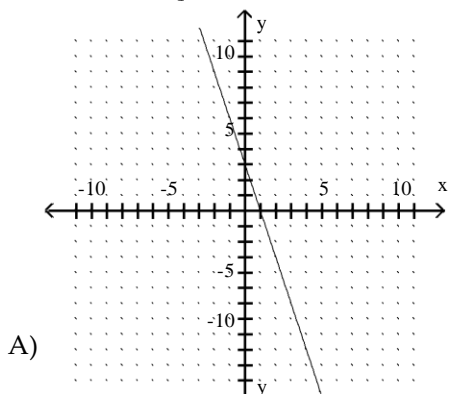
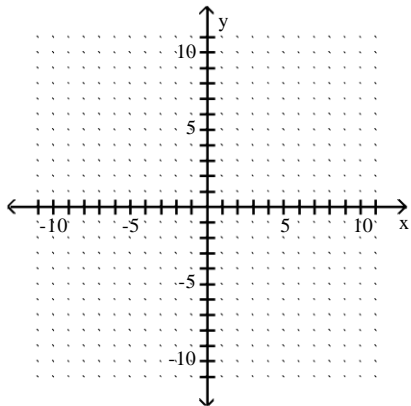

Answer:

D

124) Through  $(0, 2)$ ,  $m = -\frac{1}{5}$

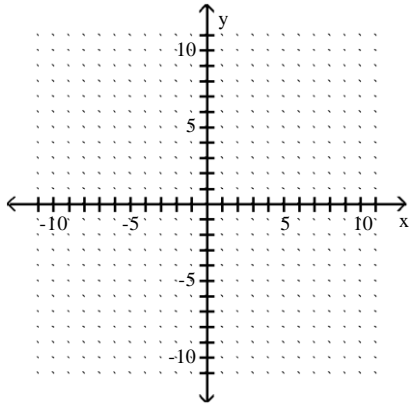

A)

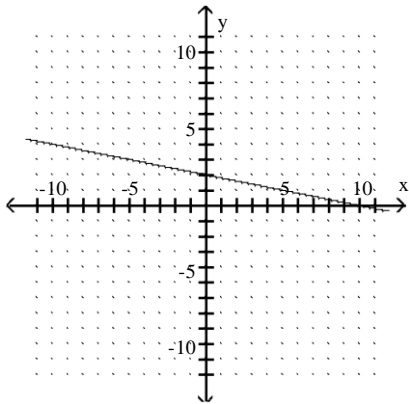

B)

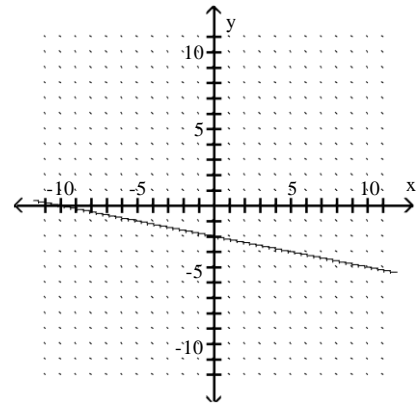

C)

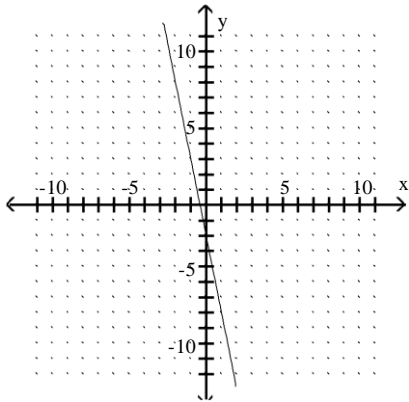

D)

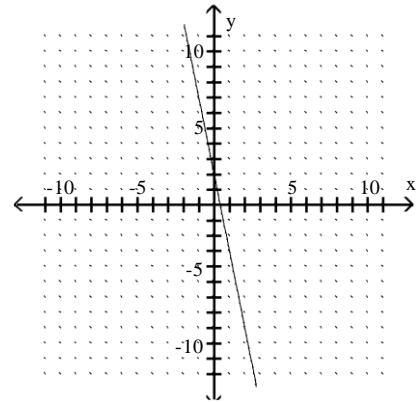

Answer: A

125) Through  $(-2, -2)$ ,  $m = 2$

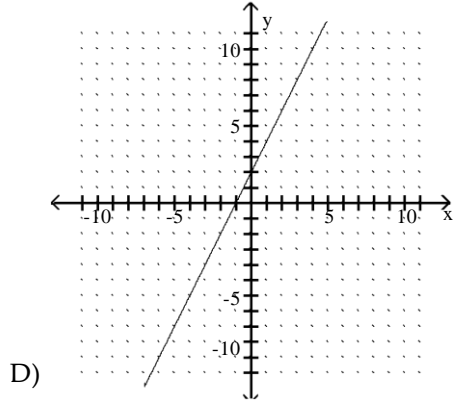
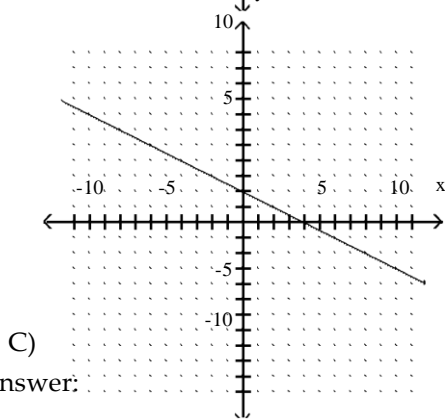
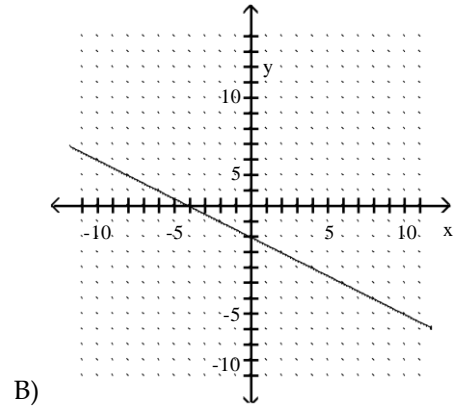
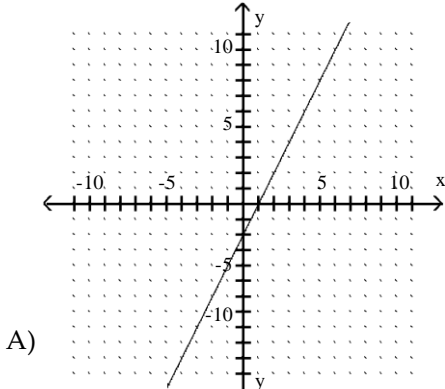
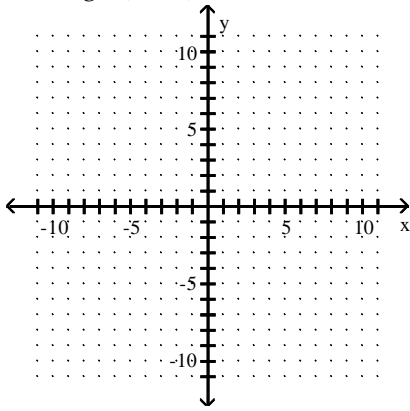

Answer:  
D

126) Through  $(2, 6)$ ,  $m = \frac{8}{3}$

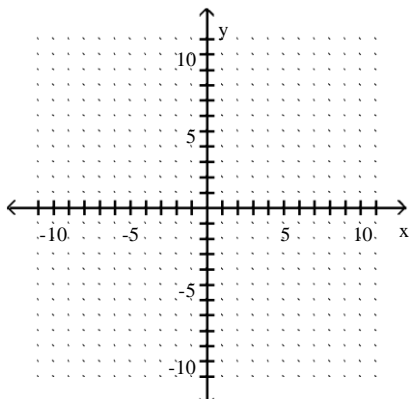



A)

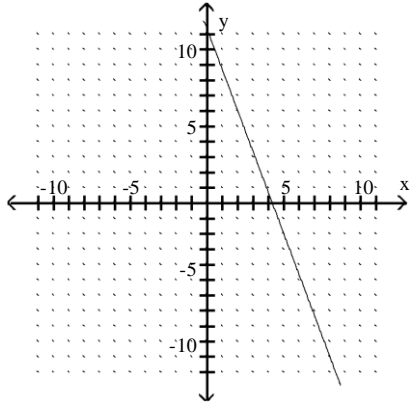

B)

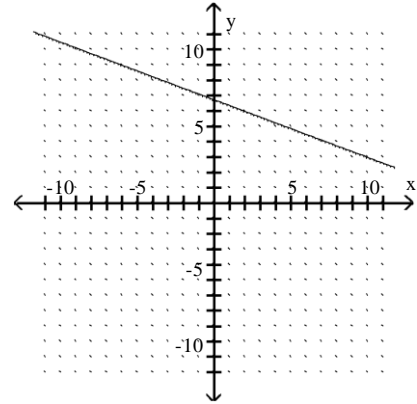

C)

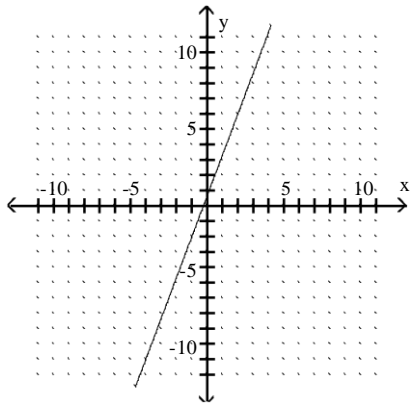

D)

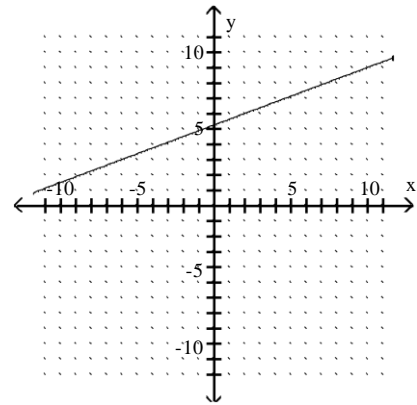

Answer: C

127) Through  $(-4, -5)$ ,  $m = 1$

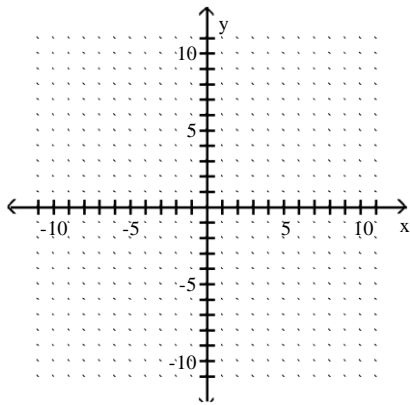

A)

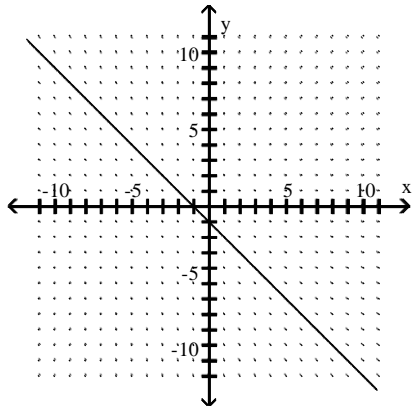

B)

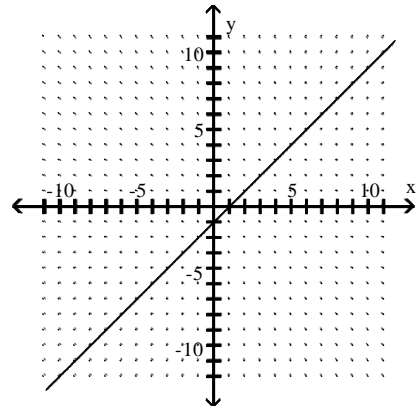

C)

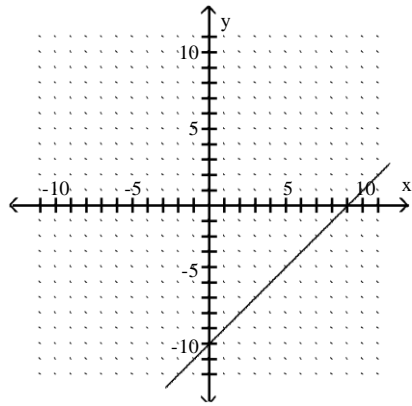

D)

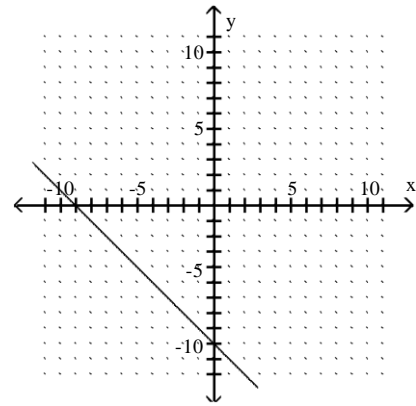

Answer: B

128) Through  $(-5, -4)$ ,  $m = \frac{3}{2}$

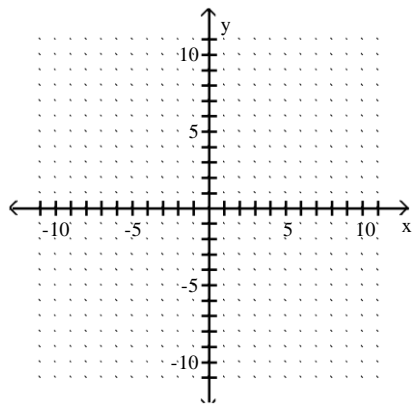

A)

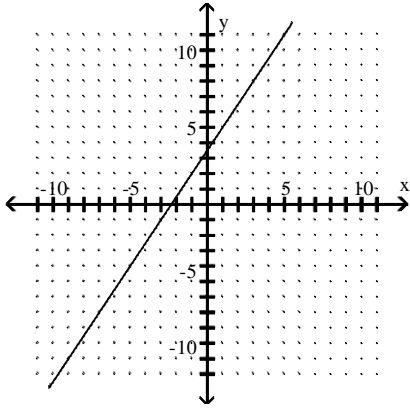

B)

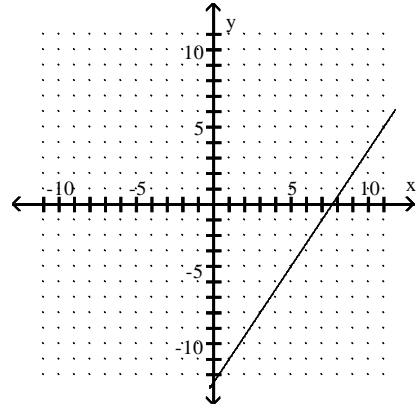

C)

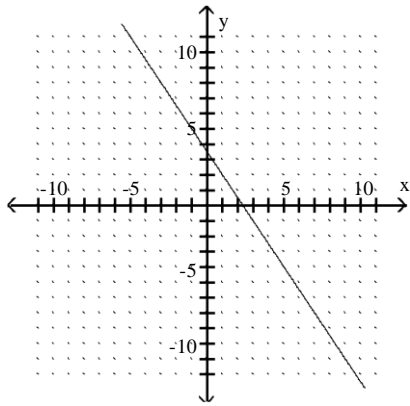

D)

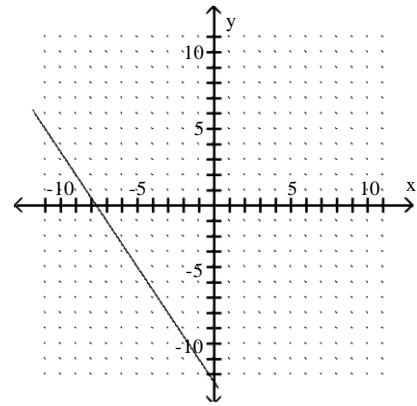

Answer: D

129) Through  $(-2, -6)$ ,  $m = 0$

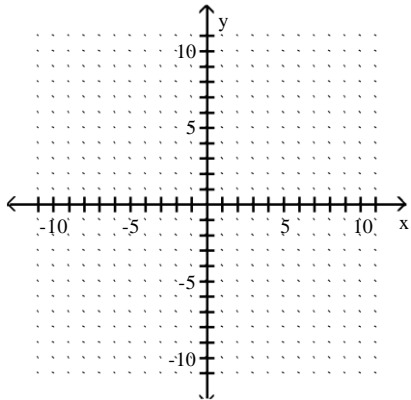

A)

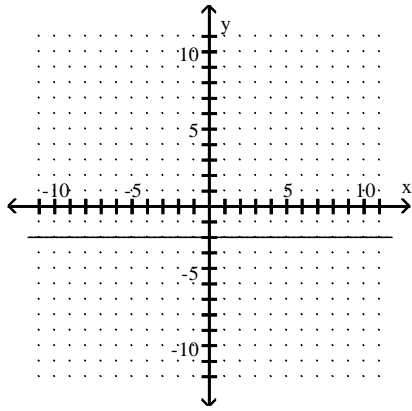

B)

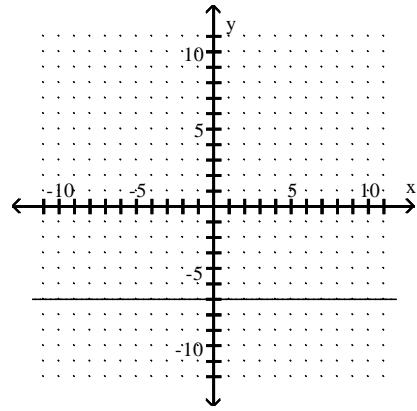

C)

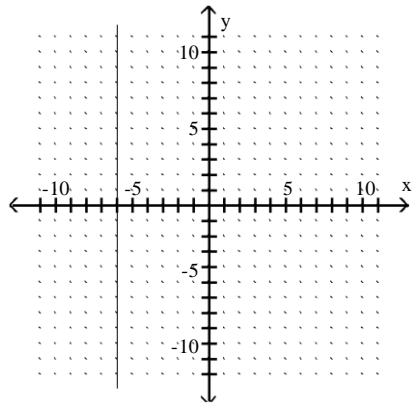

D)

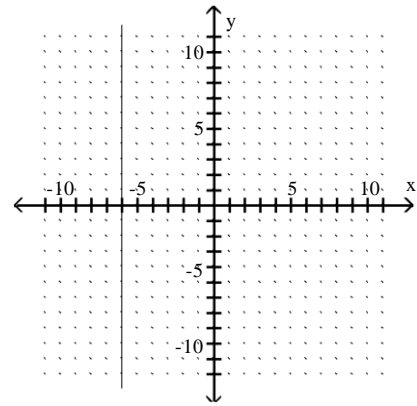

Answer: B

130) Through  $(-6, -8)$ ,  $m$  is undefined.

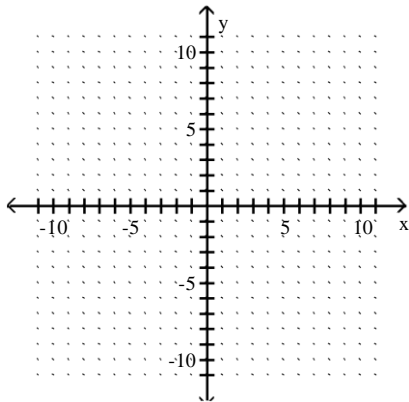

A)

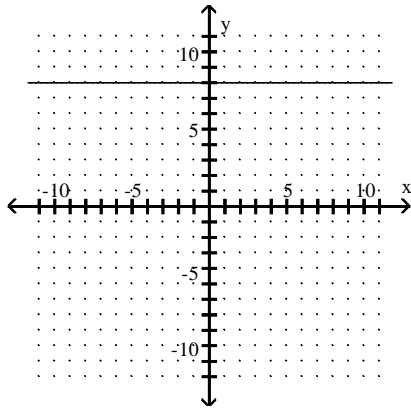

B)

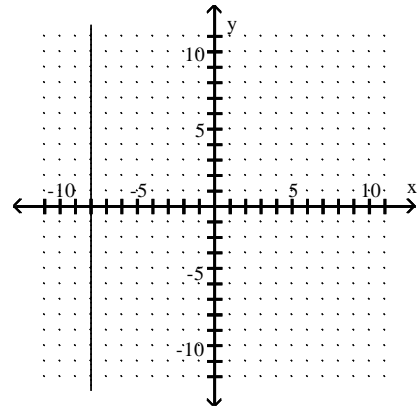

C)

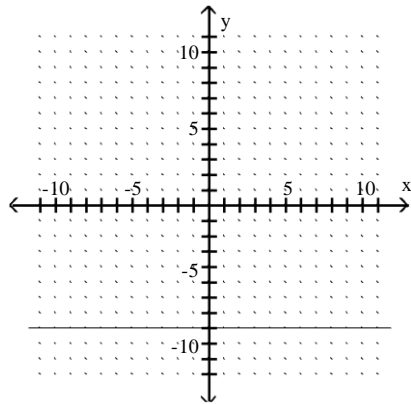

D)

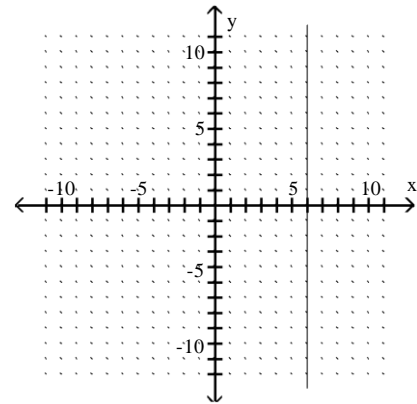

Answer: B

Find an equation in slope-intercept form for the nonvertical lines. Write the vertical lines in the form  $x = h$ .

131) Passing through  $(2, 5)$  and  $(0, -6)$

A)  $y = \frac{11}{2}x - 6$

B)  $y = -\frac{1}{2}x - 6$

C)  $y = \frac{1}{2}x - 6$

D)  $y = \frac{11}{2}x - 6$

Answer: A

132) Passing through  $(4, 0)$  and  $(-8, 7)$

A)  $y = -\frac{7}{12}x + \frac{7}{3}$

B)  $y = -\frac{4}{15}x + \frac{73}{15}$

C)  $y = \frac{4}{15}x + \frac{73}{15}$

D)  $y = \frac{7}{12}x + \frac{7}{3}$

Answer: A

133) Passing through  $(-6, -3)$  and  $(1, 8)$

A)  $y = -\frac{11}{7}x + \frac{45}{7}$

B)  $y = \frac{11}{7}x + \frac{45}{7}$

C)  $y = -\frac{3}{7}x + \frac{53}{7}$

D)  $y = \frac{3}{7}x + \frac{53}{7}$

Answer: B

134) Passing through  $(4, -8)$  and  $(-3, 9)$

A)  $y = -\frac{17}{7}x + \frac{11}{7}$

$$\frac{7}{1x+6}$$

C)  $y =$

B)  $y = \frac{17}{7}x + \frac{12}{7}$

D)  $y = -1x + 6$

— —

Answer: A

135) Passing through  $(-4, 6)$  and  $(4, 6)$

A)  $y = 2x + 0$

B)  $y = 6$

C)  $y = 3x + 4$

D)  $y = 14x + 48$

Answer: B

136) Passing through  $(-2, 5)$  and  $(-2, -5)$

A)  $x = -2$

B)  $y = -2$

C)  $y = 5$

D)  $x = 5$

Answer: A

Use the given conditions to find an equation in slope-intercept form of each of the nonvertical lines. Write vertical lines in the form  $x = h$ .

137) A vertical line through  $(0.02, 2.19)$

A)  $x = 2.19$

B)  $y = 0.02$

C)  $x = 0.02$

D)  $y = 2.19$

Answer: C

138) A horizontal line through  $(-6.24, -0.88)$

A)  $y = -0.88$

B)  $x = -0.88$

C)  $x = -6.24$

D)  $y = -6.24$

Answer: A

139)  $m = \frac{7}{5}$ ;  $y$ -intercept =  $-3$

A)  $y = -\frac{7}{5}x + 3$

B)  $y = -\frac{7}{5}x - 3$

C)  $y = \frac{7}{5}x + 3$

D)  $y = \frac{7}{5}x - 3$

Answer: D

140)  $m = -\frac{3}{7}$ ;  $y$ -intercept =  $4$

A)  $y = -\frac{3}{7}x + 4$

B)  $y = \frac{3}{7}x - 4$

C)  $y = \frac{3}{7}x + 4$

D)  $y = -\frac{3}{7}x - 4$

Answer: A

141)  $y$ -intercept  $-36$ ;  $x$ -intercept  $28$

A)  $y = \frac{9}{7}x - 36$

B)  $y = \frac{7}{9}x - 36$

C)  $y = \frac{9}{7}x + 36$

D)  $y = \frac{9}{7}x - 36$

Answer: A

142) Perpendicular to  $x = 1$ ; passing through  $(-4, 6)$

A)  $6x - 4y = 0$

B)  $y = 6$

C)  $-4x + 6y = 0$

D)  $x = -4$

Answer: B

143) Parallel to  $x = -4$ ; passing through  $(3, 7)$

A)  $y = -4$

B)  $x = 3$

C)  $y = 7$

D)  $x = 7$

Answer: B

144) Parallel to  $y = 0$ ; passing through  $(2, 7)$

A)  $y = -2$

B)  $x = 2$

C)  $x = -7$

D)  $y = 7$

Answer: D

145) Parallel to  $-4x - 3y = 1$ ; passing through  $(2, 4)$

A)  $y = -\frac{4}{3}x + \frac{20}{3}$

B)  $y = \frac{4}{3}x - \frac{1}{3}$

C)  $y = \frac{4}{3}x - \frac{20}{3}$

D)  $y = -\frac{3}{4}x - 1$

Answer: A

146) Perpendicular to  $-4x + 7y = 39$ ; passing through  $(6, 9)$

A)  $y = -\frac{7}{4}x$

B)  $y = -\frac{4}{7}x - \frac{39}{2}$

C)  $y = -\frac{4}{7}x + 78$

D)  $y = -\frac{4}{7}x + 2$

Answer: D

Find the slope and the y-intercept from the equation of the line. Sketch a graph of the equation.

147)  $y = 2x - 4$

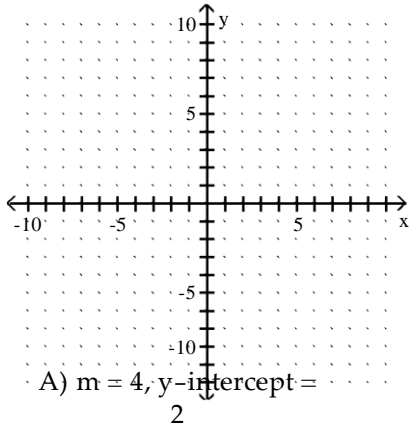

B)  $m = 2, y\text{-intercept} = 4$

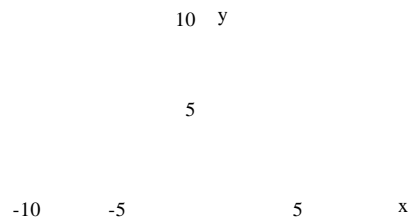
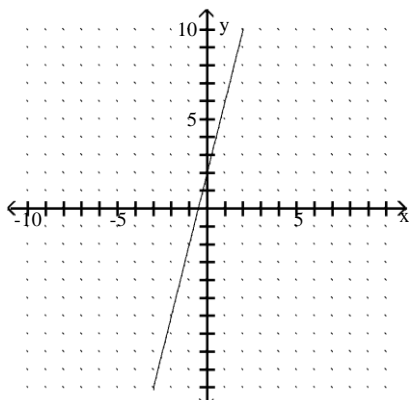
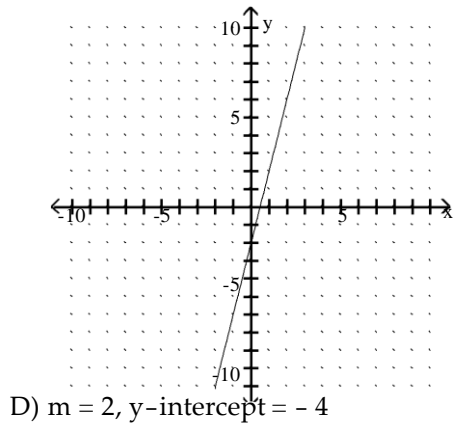
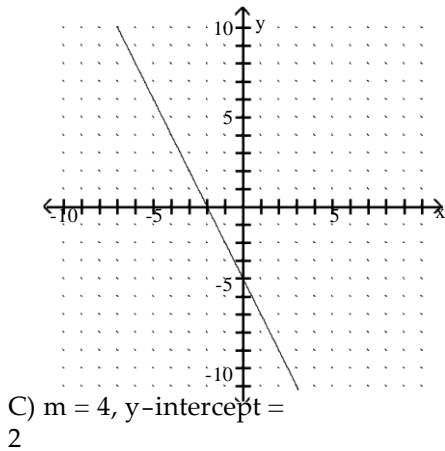



-5

-5

-10

-10

Answer: D

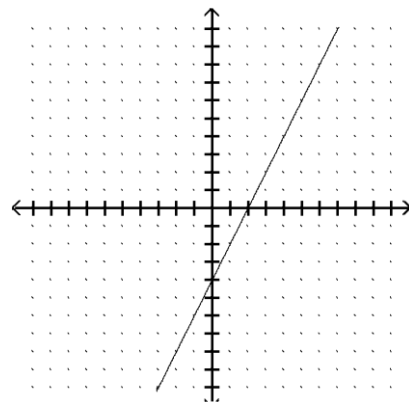

148)  $y = -\frac{1}{2}x + 3$

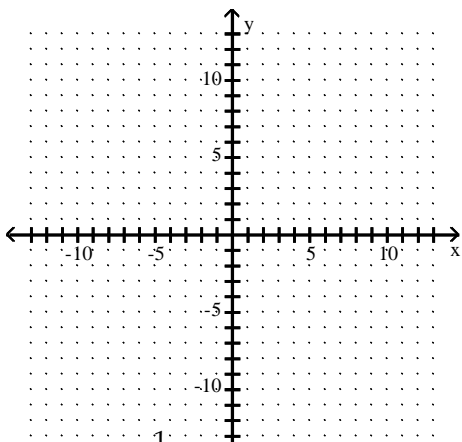

A)  $m = -\frac{1}{3}$ ; y-intercept = 2

B)  $m = \frac{1}{2}$ ; y-intercept = -3

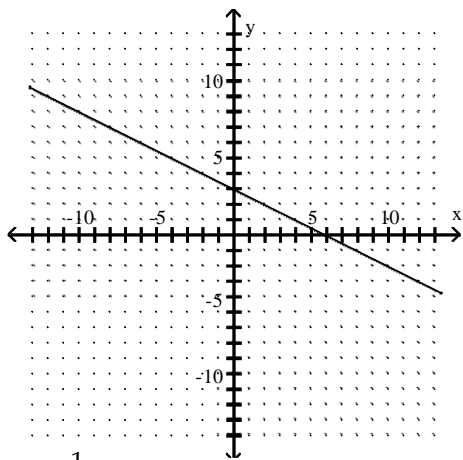

C)  $m = \frac{1}{3}$ ; y-intercept = 2

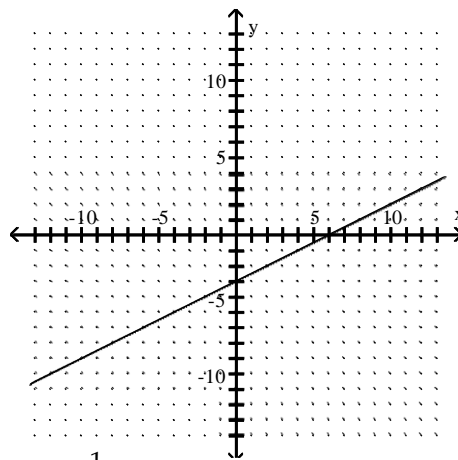

D)  $m = -\frac{1}{2}$ ; y-intercept = -3

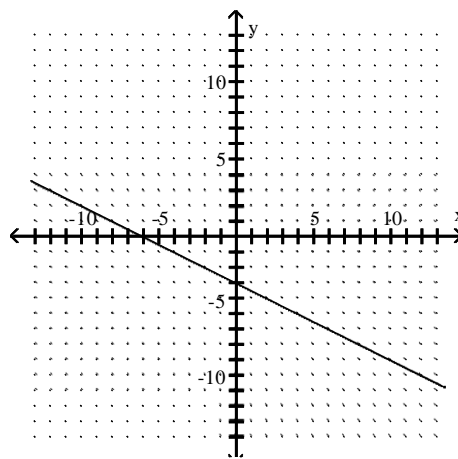
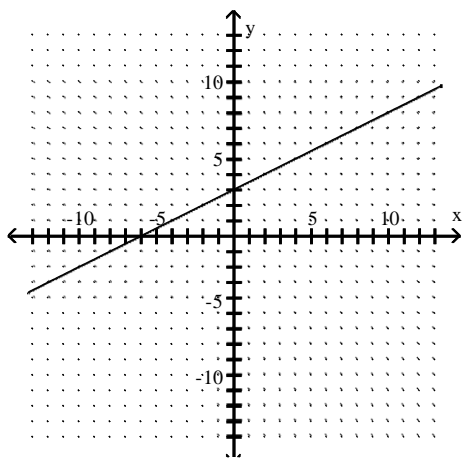

Answer: A

149)  $x + y = -3$

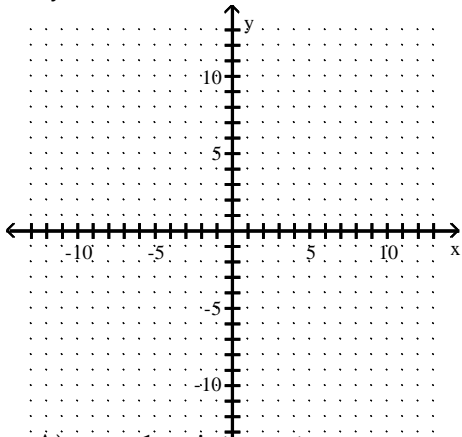

A)  $m = -1$ ; y-intercept = 3

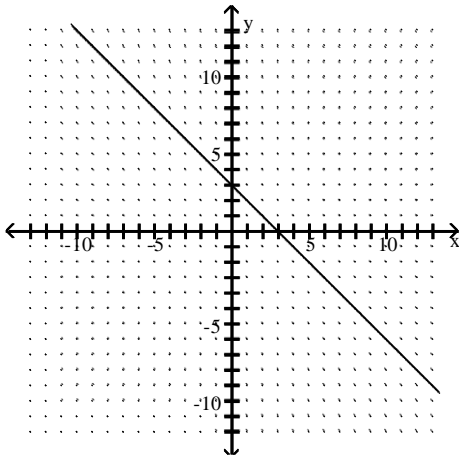

B)  $m = 1$ ; y-intercept = -3

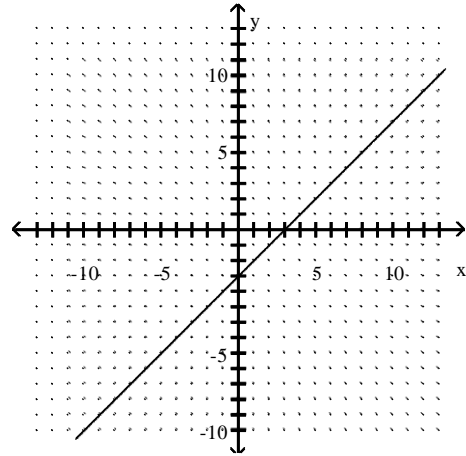

C)  $m = -1$ ; y-intercept = -3

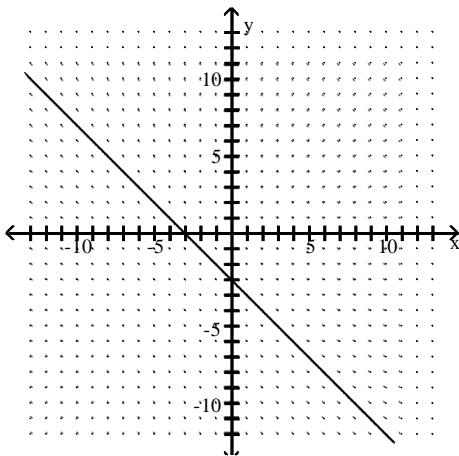

D)  $m = 1$ ; y-intercept = 3

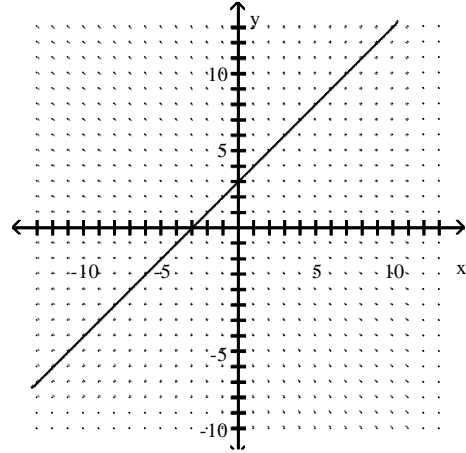

Answer: C

150)  $2x + 5y = 24$

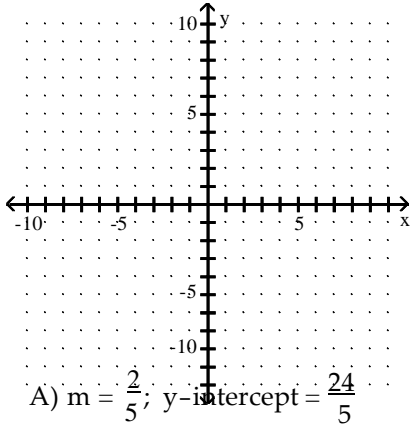

A)  $m = \frac{2}{5}$ ; y-intercept =  $\frac{24}{5}$

B)  $m = -\frac{2}{5}$ ; y-intercept =  $\frac{24}{5}$

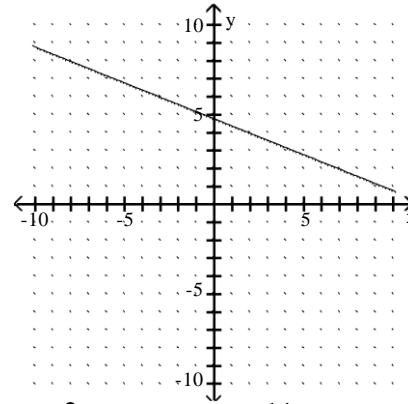
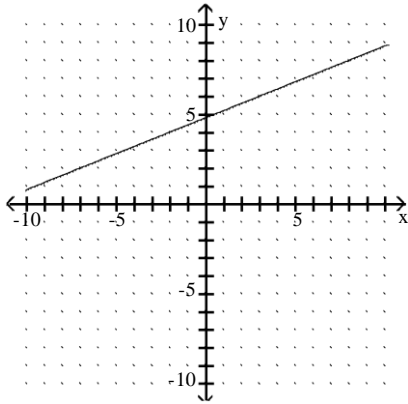

C)  $m = \frac{5}{2}$ ; y-intercept =  $\frac{14}{5}$

D)  $m = \frac{2}{5}$ ; y-intercept =  $\frac{14}{5}$

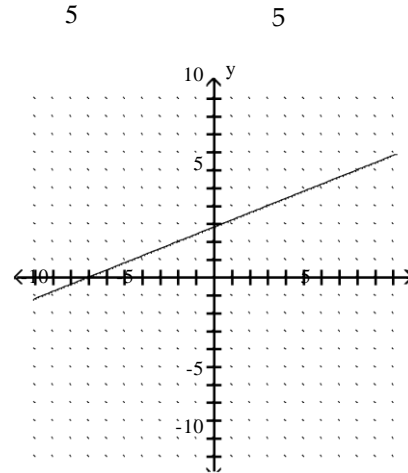
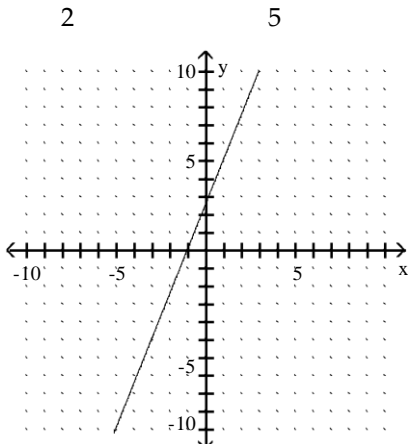

Answer: B

151)  $3x - 4y = 14$

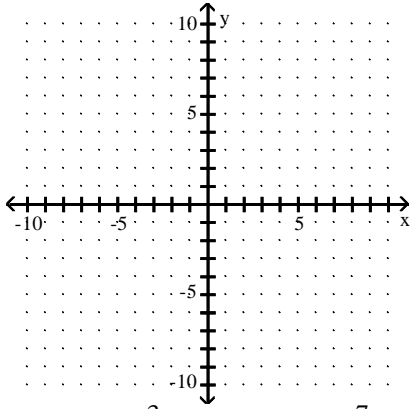

A)  $m = -\frac{3}{4}; y\text{-intercept} = \frac{7}{2}$

2

B)  $m = -\frac{3}{4}; y\text{-intercept} = -\frac{3}{2}$

—

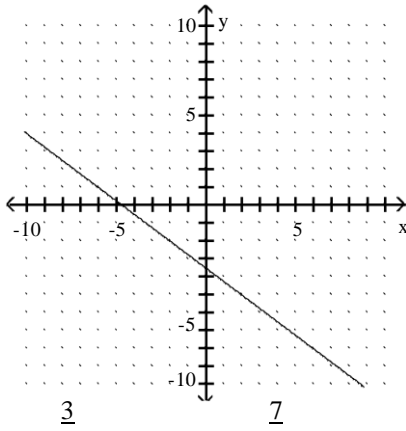

C)  $m = \frac{3}{4}; y\text{-intercept} = -\frac{7}{2}$

2

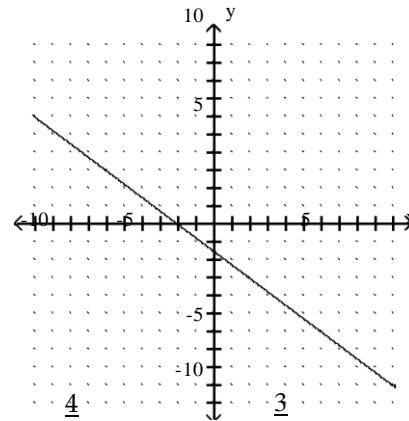

D)  $m = \frac{3}{4}; y\text{-intercept} = -\frac{7}{2}$

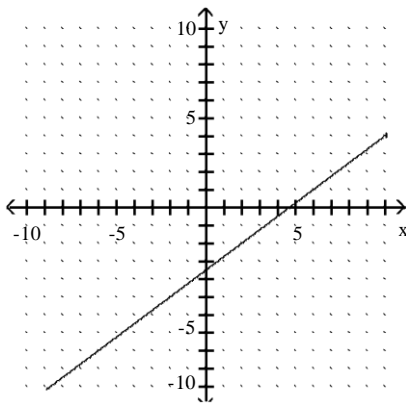

Answer: C

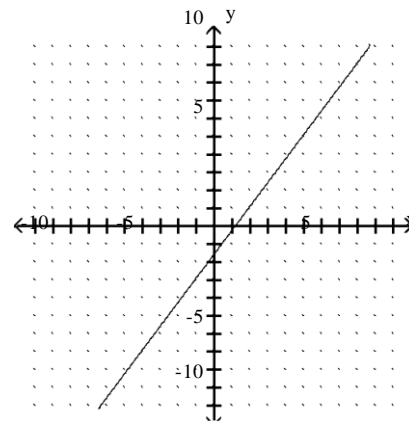

152)  $3x - 5y = -35$

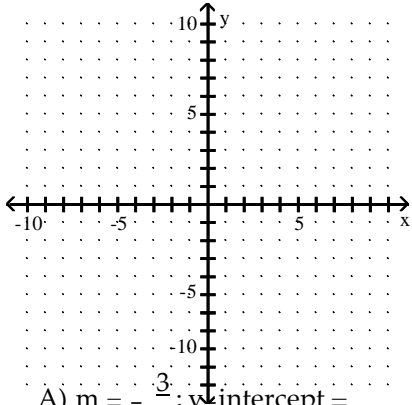

A)  $m = -\frac{3}{5}$ ; y-intercept = 7

B)  $m = -\frac{5}{3}$ ; y-intercept = 5

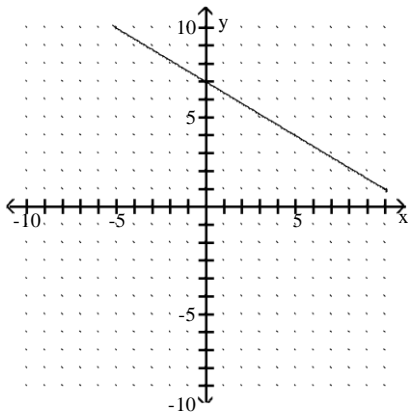

C)  $m = \frac{3}{5}$ ; y-intercept = 7

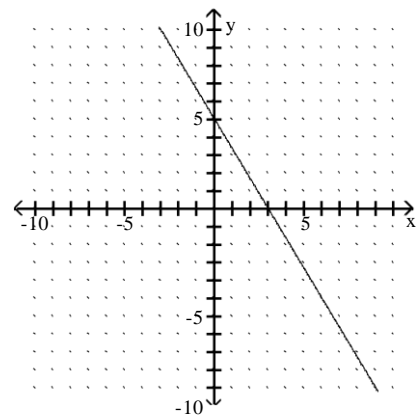

D)  $m = -\frac{3}{5}$ ; y-intercept = 5

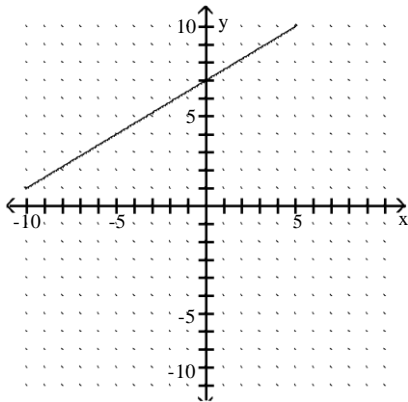

Answer: C

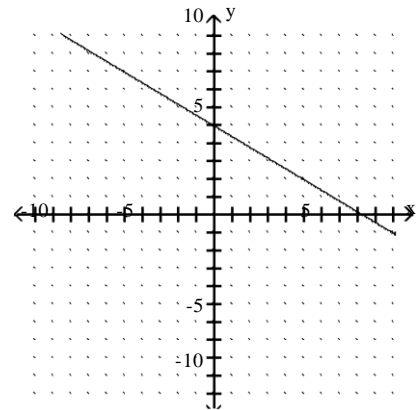

153)  $-5y = -3x -$

19

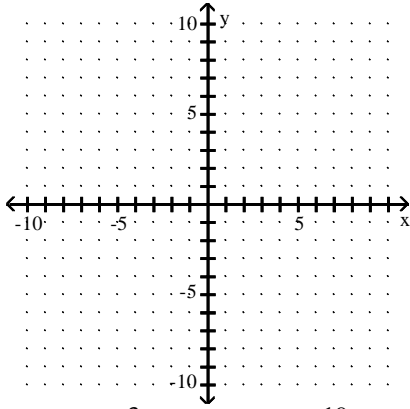

A)  $m = \frac{3}{5}; y\text{-intercept} = \frac{19}{5}$

5

B)  $m = \frac{5}{3}; y\text{-intercept} = \frac{9}{5}$

—

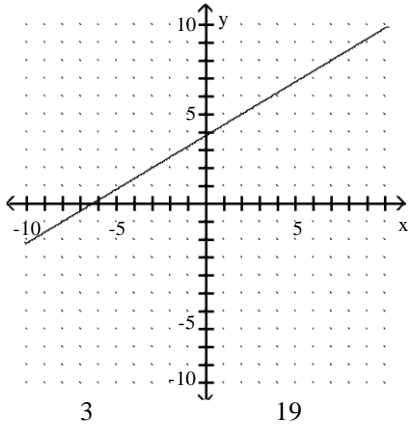

C)  $m = -\frac{3}{5}; y\text{-intercept} = \frac{19}{5}$

5

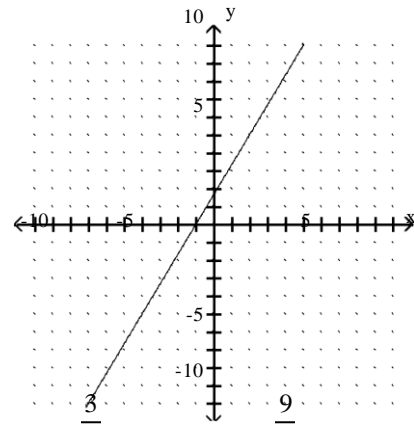

D)  $m = -\frac{5}{3}; y\text{-intercept} = \frac{9}{5}$

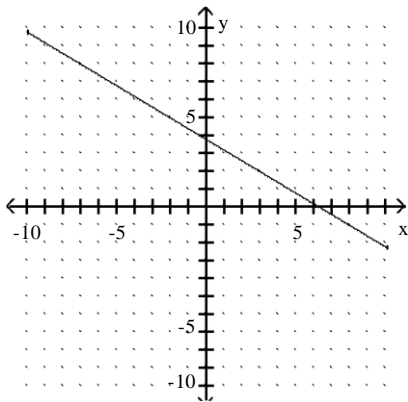

Answer: A

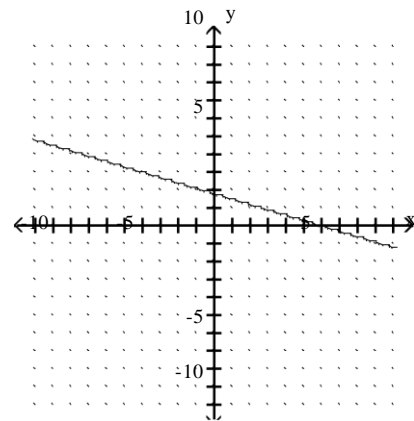

154)  $5x - 2y + 9 = 0$

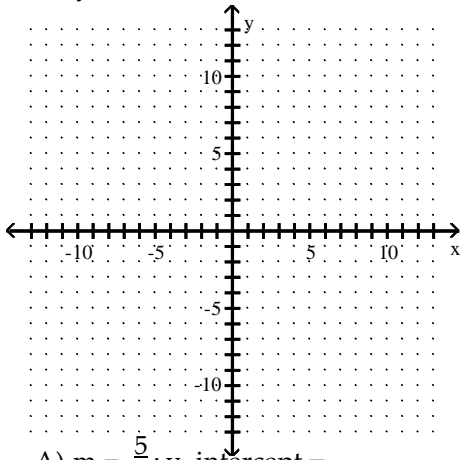

A)  $m = \frac{5}{2}$ ; y-intercept =

B)  $m = -\frac{5}{2}$ ; y-intercept =  $\frac{9}{2}$

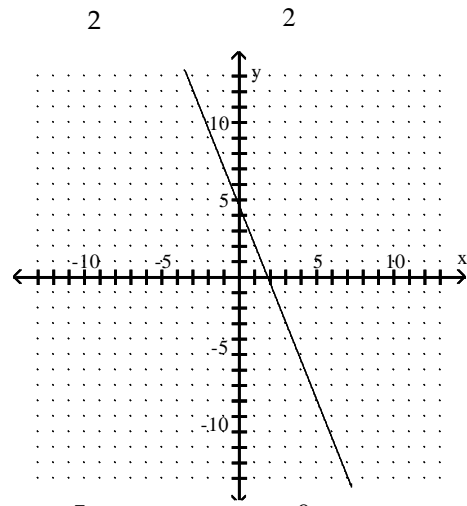
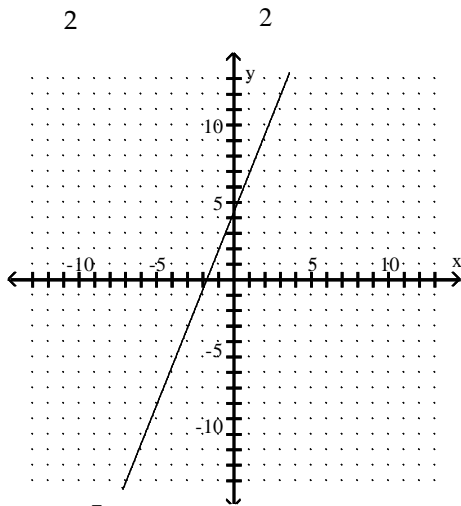

C)  $m = -\frac{5}{2}$ ; y-intercept = -

D)  $m = \frac{5}{2}$ ; y-intercept =  $-\frac{9}{2}$

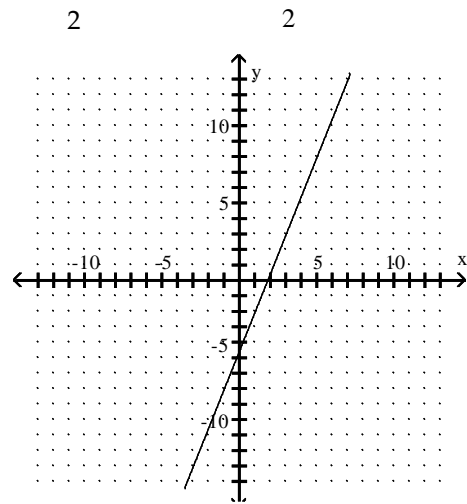
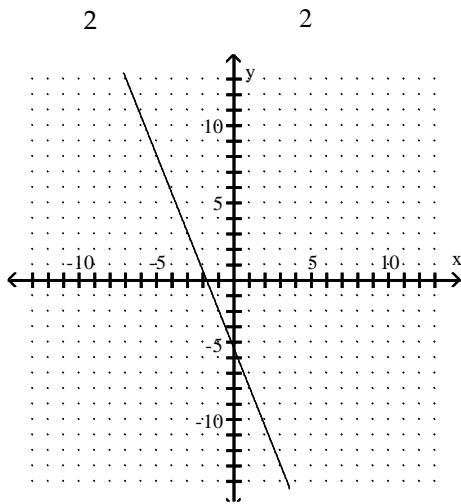

Answer: A



155)  $y = -2$

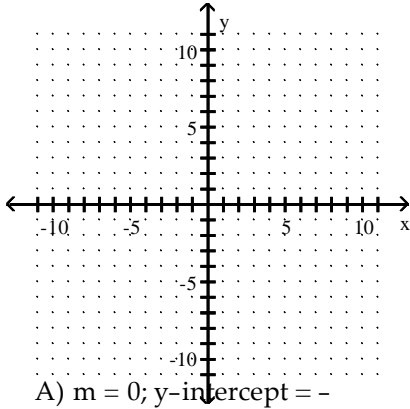

A)  $m = 0$ ; y-intercept = -2

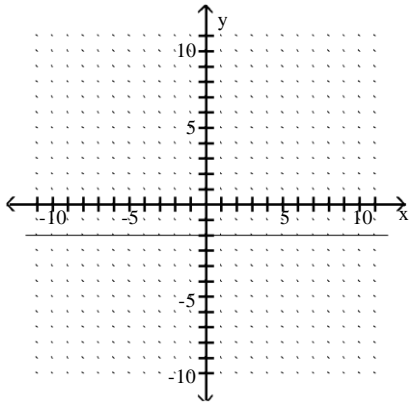

C)  $m = 0$ ; y-intercept = none

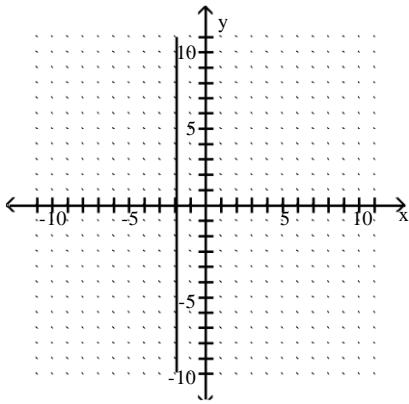

B)  $m = \text{undefined}$ ; y-intercept = none

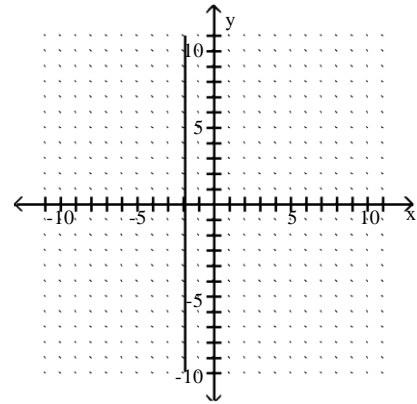

D)  $m = \text{undefined}$ ; y-intercept = -2

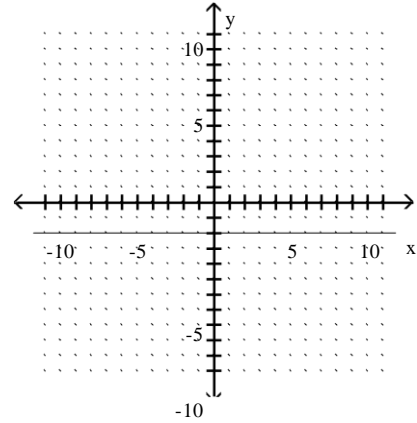

Answer: A

156)  $x = -4$

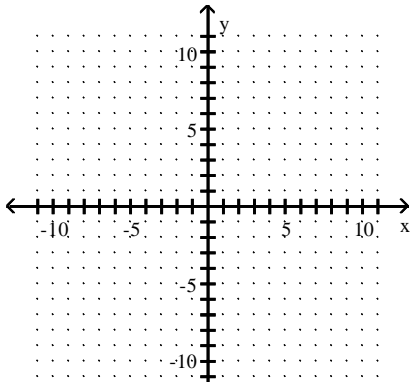

A)  $m = 0$ ; y-intercept = -4

B)  $m = \text{undefined}$ ; y-intercept = none

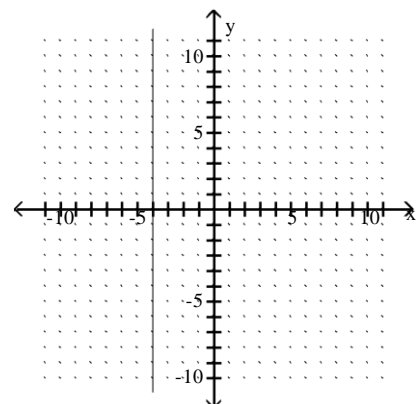
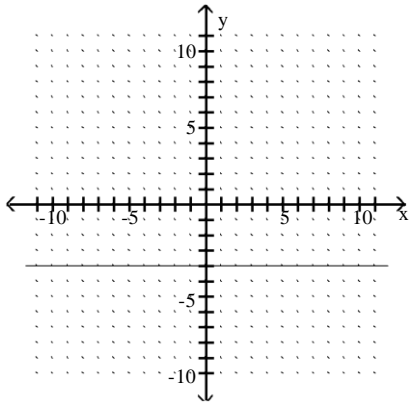

C)  $m = \text{undefined}$ ; y-intercept = none

D)  $m = -4$ ; y-intercept = 0

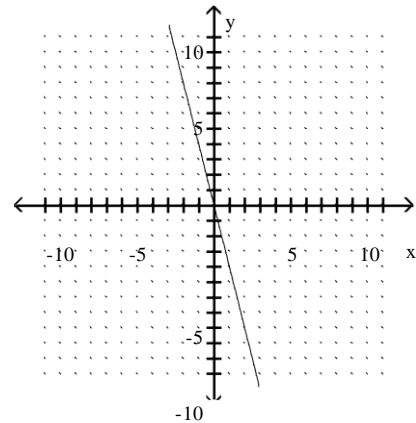
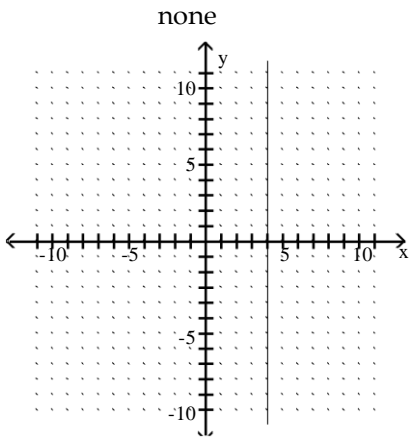

Answer: B

Determine whether the pair of lines is parallel, perpendicular, or neither.

157)  $3x - 2y = -15$   
 $2x + 3y = -15$

A) Parallel

B) Perpendicular

C) Neither

Answer: B

158)  $3x - 2y = -5$   
 $2x + 3y = -5$

A) Parallel

B) Perpendicular

C) Neither

Answer: B

159)  $12x + 4y = 16$   
 $24x + 8y = 33$

A) Parallel

B) Perpendicular

C) Neither

Answer: A

160)  $12x + 4y = 16$   
 $6x + 2y = 12$

A) Parallel

B) Perpendicular

C) Neither

Answer: A

161)  $4x - 6y = -13$   
 $8x + 6y = -13$

A) Parallel

B) Perpendicular

C) Neither

Answer: C

162)  $y + 6 = -4x$   
 $5y = 25x - 18$

A) Parallel

B) Perpendicular

C) Neither

Answer: C

163)  $y - 9 = -$   
 $x \quad y - x = 9$

A) Parallel

B) Perpendicular

C) Neither

Answer: B

164)  $y = 3 - 3.5x$   
 $y = -\frac{7}{2}x - 3$

A) Parallel

B) Perpendicular

C) Neither

Answer: A

165)  $y = -\frac{13}{8}x + 1$

$y = \frac{8}{13}x + 1$

A) Parallel

B) Perpendicular

C) Neither

Answer: B

Solve the problem.

166) To convert a temperature from degrees Celsius to degrees Fahrenheit, you multiply the temperature in degrees

Celsius by 1.8 and then add 32 to the result. Find a linear equation to convert from degrees Celsius to degrees

Fahrenheit.

A)  $F = 33.8c$   
32

B)  $F = 1.8 + 32c$

C)  $F = \frac{c}{1.8}$

D)  $F = 1.8c + 32$

1.8

Answer: D

167) If an object is dropped off of a tower, the velocity,  $V$ , of the object after  $t$  seconds can be obtained by multiplying  $t$  by 32 and adding 10 to the result. Find an equation relating the velocity,  $V$ , to the number of seconds,  $t$ .

- A)  $V = 32t + 10$                       B)  $V = 42t$                       C)  $V = \frac{t-10}{32}$                       D)  $V = 32 + 10t$

Answer: A

168) The cost for labor associated with fixing a washing machine is computed as follows: There is a fixed charge of \$30 for the repairman to come to the house, to which a charge of \$28 per hour is added. Find an equation that can be used to determine the labor cost,  $C$ , of a repair that takes  $x$  hours.

- A)  $C = 30 - 28x$                       B)  $C = 30 + 28x$                       C)  $C = 28 + 30x$                       D)  $C = (30 + 28)x$

Answer: B

169) In a certain city, the cost of a taxi ride is computed as follows: There is a fixed charge of \$2.10 as soon as you get in the taxi, to which a charge of \$2.25 per mile is added. Find an equation that can be used to determine the cost,  $C$ , of an  $x$ -mile taxi ride.

- A)  $C = 2.25 + 2.10x$                       B)  $C = 4.35x$                       C)  $C = 2.10 + 2.25x$                       D)  $C = 2.85x$

Answer: C

170) Marty's Tee Shirt & Jacket Company is to produce a new line of jackets with an embroidery of a Great Pyrenees dog on the front. There are fixed costs of \$660 to set up for production, and variable costs of \$48 per jacket. Write an equation that can be used to determine the total cost,  $C$ , encountered by Marty's Company in producing  $x$  jackets.

- A)  $C = (660 + 48)x$                       B)  $C = 660 + 48x$                       C)  $C = 660x + 48$                       D)  $C = 660 - 48x$

Answer: B

171) The average value of a certain type of automobile was \$14,880 in 1993 and depreciated to \$6120 in 1997. Let  $y$  be the average value of the automobile in the year  $x$ , where  $x = 0$  represents 1993. Write a linear equation that models the value of the automobile in terms of the year  $x$ .

- A)  $y = -2190x + 6120$                       B)  $y = -2190x + 14,880$                       C)  $y = -2190x - 2640$                       D)  $y = \frac{1}{2190}x - 6120$

Answer: B

172) An investment is worth \$2140 in 1995. By 2000 it has grown to \$3640. Let  $y$  be the value of the investment in the year  $x$ , where  $x = 0$  represents 1995. Write a linear equation that models the value of the investment in the year  $x$ .

- A)  $y = 300x + 2140$                       B)  $y = \frac{1}{300}x + 2140$                       C)  $y = -300x + 2140$                       D)  $y = -300x + 5140$

Answer: A

173) A faucet is used to add water to a large bottle that already contained some water. After it has been filling for 5 seconds, the gauge on the bottle indicates that it contains 29 ounces of water. After it has been filling for 12 seconds, the gauge indicates the bottle contains 64 ounces of water. Let  $y$  be the amount of water in the bottle  $x$  seconds after the faucet was turned on. Write a linear equation that models the amount of water in the bottle in terms of  $x$ .

- A)  $y = -5x + 54$                       B)  $y = 5x + 52$                       C)  $y = 5x + 4$                       D)  $y = \frac{1}{5}x + 28$

Answer: C

174) When making a telephone call using a calling card, a call lasting 6 minutes cost \$1.95. A call lasting 13 minutes cost \$3.70. Let  $y$  be the cost of making a call lasting  $x$  minutes using a calling card. Write a linear equation that models the cost of a making a call lasting  $x$  minutes.

- A)  $y = 0.25x - 9.3$       B)  $y = 4x \frac{441}{20}$       C)  $y = -0.25x + 3.45$       D)  $y = 0.25x + 0.45$

Answer: D

175) A vendor has learned that, by pricing carmel apples at \$1.00, sales will reach 106 carmel apples per day. Raising the price to \$2.00 will cause the sales to fall to 54 carmel apples per day. Let  $y$  be the number of carmel apples the vendor sells at  $x$  dollars each. Write a linear equation that models the number of carmel apples sold per day when the price is  $x$  dollars each.

- A)  $y = -52x - 158$       B)  $y = 52x + 54$       C)  $y = \frac{1}{52}x \frac{5511}{52}$       D)  $y = -52x + 158$

Answer: D

176) The cost of manufacturing a molded part is related to the quantity produced during a production run. When 100 parts are produced, the cost is \$300. When 300 parts are produced, the cost is \$1700. What is the average cost per part?

- A) \$7.00 per part      B) \$4.67 per part      C) \$0.14 per part      D) \$8.00 per part

Answer: A

177) A cross-country skier reaches the 15-km mark of a race 40 min after reaching the 5-km mark. Find the speed of the skier.

- A)  $\frac{45}{2}$  km/hr      B) 15 km/hr      C) 40 km/hr      D) 10 km/hr

Answer: B

178) To convert a temperature from degrees Celsius to degrees Fahrenheit, you multiply the temperature in degrees Celsius by 1.8 and then add 32 to the result. Find a linear equation to convert from degrees Celsius to degrees Fahrenheit. Use this function to convert 13° C to °F.

- A) 46.4°F      B) 43.1°F      C) 50.7°F      D) 55.4°F

Answer: D

179) If an object is dropped from a tower, then the velocity,  $V$  (in feet per second), of the object after  $t$  seconds can be obtained by multiplying  $t$  by 32 and adding 10 to the result. Find an equation relating the velocity,  $V$ , to the number of seconds,  $t$ . Use this equation to find the velocity of the object at time  $t = 1.1$  seconds.

- A) 43.2 ft/sec      B) 46.5 ft/sec      C) 44.5 ft/sec      D) 45.2 ft/sec

Answer: D

180) In a certain city, the cost of a taxi ride is computed as follows: There is a fixed charge of \$2.10 as soon as you get in the taxi, to which a charge of \$1.55 per mile is added. Find an equation that can be used to determine the cost,  $C$ , of an  $x$ -mile taxi ride, and use this equation to find the cost of a 8-mile taxi ride.

- A) \$14.68      B) \$14.50      C) \$15.40      D) \$14.38

Answer: B

- 181) Marty's Tee Shirt & Jacket Company is to produce a new line of jackets with a embroidery of a Great Pyrenees dog on the front. There are fixed costs of \$650 to set up for production, and variable costs of \$32 per jacket. Write an equation that can be used to determine the total cost,  $C$ , encountered by Marty's Company in producing  $x$  jackets, and use the equation to find the total cost of producing 144 jackets.
- A) \$5250                      B) \$5270                      C) \$5258                      D) \$5238

Answer: C

- 182) The cost of owning a home includes both fixed costs and variable utility costs. Assume that it costs \$1721 per month for mortgage and insurance payments and it costs an average of \$1.20 per unit for natural gas, electricity, and water usage. (i) Determine a linear function that computes the annual cost of owning this home if  $x$  utility units are used. (ii) What does the  $y$ -intercept on the graph of the function represent?
- A)  $y = -1.20x + 1721$ ;  $y$ -intercept, 1721, represents the minimum cost of owning the home without spending anything on utilities.
- B)  $y = -1.20x + 20,652$ ;  $y$ -intercept, 20,652, represents the minimum cost of owning the home for 12 months without spending anything on utilities.
- C)  $y = 1.20x + 20,652$ ;  $y$ -intercept, 20,652, represents the minimum cost of owning the home for 12 months without spending anything on utilities.
- D)  $y = 1.20x + 1721$ ;  $y$ -intercept, 1721, represents the minimum cost of owning the home without spending anything on utilities.

Answer: C

Provide an appropriate response.

- 183) In the linear equation,  $y = mx + b$ ,  $b$  is the     ? of the equation.
- A) slope                      B) domain                      C)  $x$ -intercept                      D)  $y$ -intercept

Answer: D

- 184) In the linear equation,  $y = mx + b$ ,  $m$  is     ? of the equation.
- A)  $x$ -intercept                      B) range                      C) slope                      D)  $y$ -intercept

Answer: C

- 185) In the linear equation,  $y = -10 - 9x$ ,  $-10$  is     ? of the equation.
- A)  $y$ -intercept                      B) slope                      C)  $x$ -intercept                      D) domain

Answer: A

- 186) If the  $y$ -intercept of the linear equation  $y = 4x + b$  lies below the  $x$ -axis, then what can you say about  $b$ ?
- A)  $b = 0$                       B)  $b \geq 0$                       C)  $b > 0$                       D)  $b < 0$

Answer: D

- 187) If  $m > 0$ , the graph of  $y = mx + b$      ?
- A) is somewhat flat                      B) slopes upward to the right
- C) is very steep                      D) is a horizontal line

Answer: B

- 188) For the equation  $y = mx + b$ , find a formula for the value of  $x$  given any value of  $y$ .
- A)  $x = y - mx - b$                       B)  $x = \frac{y+b}{m}$                       C)  $x = \frac{y-b}{m}$                       D)  $x = \frac{my-b}{b}$

Answer: C



189) A line passes through the points (2, 5) and (2, 10). The equation of this line is      ? . The slope of the line is      ?

- A)  $x = 2; 0$                                       B)  $x = 2; \text{undefined}$                                       C)  $y = 2; \text{undefined}$                                       D)  $y = 2; 0$

Answer: B

190) A line passes through the points (8, 3) and (1, 3). The equation of this line is      ? . The slope of the line is      ?

- A)  $y = 3; 0$                                       B)  $y = 3; \text{undefined}$                                       C)  $x = 3; \text{undefined}$                                       D)  $x = 3; 0$

Answer: A

SHORT ANSWER. Write the word or phrase that best completes each statement or answers the question.

191) Can an equation of a vertical line be written in slope-intercept form? Explain.

Answer: No. In the slope-intercept form of the equation of a line,  $x$  is multiplied by slope; however, the slope of a vertical line is undefined. (Explanations will vary.)

MULTIPLE CHOICE. Choose the one alternative that best completes the statement or answers the question. Determine the domain and range of the relation. State whether the relation is a function or not a function.

192)

|    |   |    |
|----|---|----|
| 4  | → | 20 |
| 7  | → | 35 |
| 10 | → | 50 |
| 13 | → | 65 |

- A) domain: {4, 7, 10, 13}  
range: {20, 35, 50, 65}  
not a function
- B) domain: {4, 7, 10, 13}  
range: {20, 35, 50, 65}  
function
- C) domain: {20, 35, 50, 65}  
range: {4, 7, 10, 13}  
not a function
- D) domain: {20, 35, 50, 65}  
range: {4, 7, 10, 13}  
function

Answer: B

193)

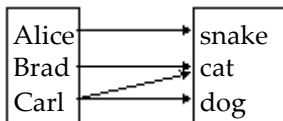

- A) domain: {Alice, Brad, Carl}  
range: {snake, cat, dog}  
not a function
- B) domain: {snake, cat, dog}  
range: {Alice, Brad, Carl}  
not a function
- C) domain: {snake, cat, dog}  
range: {Alice, Brad, Carl}  
function
- D) domain: {Alice, Brad, Carl}  
range: {snake, cat, dog}  
function

Answer: A

194)

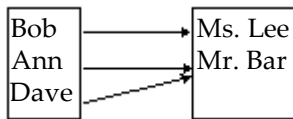

- A) domain: {Ms. Lee, Mr. Bar}  
range: {Bob, Ann, Dave}  
function
- C) domain: {Bob, Ann, Dave} range: {Ms. Lee, Mr. Bar} function

- B) domain: {Bob, Ann, Dave}  
range: {Ms. Lee, Mr. Bar}  
not a function
- D) domain: {Ms. Lee, Mr. Bar} range: {Bob, Ann, Dave} not a function

Answer: C

195)

|   |   |   |   |   |
|---|---|---|---|---|
| x | 3 | 8 | 3 | 4 |
| y | 4 | 8 | 3 | 1 |

- A) domain: {3, 1, 8, 4} range: {3, 1, 8, 4} not a function
- B) domain: {3, 1, 8, 4} range: {3, 4, 8} function
- C) domain: {3, 1, 8, 4} range: {3, 4, 8} not a function
- D) domain: {3, 4, 8} range: {3, 1, 8, 4} function

Answer: A

196)

|   |    |    |   |   |
|---|----|----|---|---|
| x | -2 | -1 | 1 | 2 |
| y | 1  | 7  | 1 | 7 |

- A) domain: {-2,-1, 1, 2} range: { 1, 7} function
- C) domain: {-2,-1, 1, 2} range: { 1, 7} not a function
- B) domain: { 1, 7} range: {-2,-1, 1, 2} function
- D) domain: { 1, 7} range: {-2,-1, 1, 2} not a function

Answer: A

Determine whether the equation defines y as a function of x.

197)  $y = 5x - 8$

- A) Yes

- B) No

Answer: A

198)  $7x = 4 - 5y$

- A) Yes

- B) No

Answer: A

199)  $y = x^2 + 4$

- A) Yes

- B) No

Answer: A

200)  $y = 2x^2 - 5x + 5$

- A) Yes

- B) No

Answer: A

201)  $x = y^3$   
A) Yes  
Answer: A

B) No

202)  $x = y^2 + 1$   
A) Yes  
Answer: B

B) No

203)  $x = |3y|$   
A) Yes  
Answer: B

B) No

204)  $y^2 = 3x$   
A) Yes  
Answer: B

B) No

205)  $y = \sqrt{2x - 6}$   
A) Yes  
Answer: A

B) No

206)  $xy = 7$   
A) Yes  
Answer: A

B) No

Find the function value.

207) Let  $f(x) = x^2 + 4x - 1$ . Find  $f(-3)$ .  
A) -4  
B) 20  
C) 22  
D) -2  
Answer: A

208) Let  $f(x) = \frac{x}{11 - x}$ . Find  $f\left(-\frac{1}{5}\right)$ .  
A) 56  
B)  $-\frac{1}{56}$   
C)  $\frac{1}{56}$   
D) -56  
Answer: B

209) Let  $g(x) = \frac{x-3}{x+7}$ . Find  $g(-10.25)$ .  
A) 1  
B)  $-\frac{29}{69}$   
C)  $\frac{53}{13}$   
D)  $\frac{29}{69}$   
Answer: C

210) Let  $g(x) = \frac{x}{\sqrt{4 - x^2}}$ . Find  $g(0)$ .  
A) 0  
B) does not exist  
C) 1  
D) 4  
Answer: A

211) Let  $f(x) = 5x^2 - 3x + 6$ . Find  $f(-x)$ .

A)  $-5x^2 + 4x + 6$

B)  $-5x^2 + 3x - 6$

C)  $4x^2 + 4x + 5$

D)  $5x^2 + 3x + 6$

Answer: D

212) Let  $g(x) = 3x^3$ . Find  $g(2 + h)$ .

A)  $24 + 36h + 18h^2 + 3h^3$

C)  $-24 + 36h - 9h^2 + h^3$

B)  $8 + 12h + 18h^2 + 4h^3$

D)  $24 - 36h + 12h^2 - 3h^3$

Answer: A

213) Let  $f(x) = 4|x| + 3x$ . Find  $f(4y)$ .

A)  $4|y| + 4y$

B)  $4|y| + 3y$

C)  $8|y| + 12y$

D)  $7|y| + 14y$

Answer: C

214) Let  $h(x) = 2x - \sqrt{x^2 - 3}$ . Find  $h(-x)$ .

A)  $-2x - \sqrt{x^2 - 3}$

B)  $2x - \sqrt{x^2 - 3}$

C)  $-2x + \sqrt{x^2 - 3}$

D)  $-2x + \sqrt{3 - x^2}$

$x^2$

Answer: A

Find the domain of the function.

215)  $f(x) = 3x - 7$

A)  $(-\infty, 0) \cup (0, \infty)$

B)  $(-\infty, \infty)$

C)  $(0, \infty)$

D)  $(7, \infty)$

Answer: B

216)  $f(x) = \frac{x}{x - 8}$

A)  $(-\infty, -8) \cup (-8, \infty)$

B)  $(-\infty, 8) \cup (8, \infty)$

C)  $(-\infty, 0)$

D)  $(0, \infty)$

Answer: B

217)  $f(x) = \frac{5}{x + 4}$

A)  $(-\infty, 0) \cup (0, \infty)$

B)  $(-\infty, \infty)$

C)  $(-\infty, -4) \cup (-4, \infty)$

D)  $(-\infty, \infty)$

Answer: C

218)  $f(x) = \frac{1}{x^2 + 4x - 12}$

A)  $(-\infty, 2) \cup (2, \infty)$

C)  $(-\infty, -6) \cup (-6, \infty)$

B)  $(-\infty, -6) \cup (-6, 2) \cup (2, \infty)$

D)  $(-\infty, \infty)$

Answer: B

219)  $f(x) = \frac{x^4 - 2x^3 + 4}{3x^2 - 16x - 35}$

A)  $(-\infty, -7) \cup \left(-7, \frac{5}{3}\right) \cup \left(\frac{5}{3}, \infty\right)$

C)  $\left(-\infty, -\frac{5}{3}\right) \cup \left(-\frac{5}{3}, \infty\right)$

B)  $(-\infty, 7) \cup (7, \infty)$

D)  $\left(-\infty, \frac{5}{3}\right) \cup \left(\frac{5}{3}, 7\right) \cup (7, \infty)$

Answer: D

220)  $f(x) = \sqrt{17 - x}$

A)  $(-\infty, \infty)$

B)  $(\sqrt{17}, \infty)$

C)  $(-\infty, 17]$

D)  $(-\infty, 17) \cup (17,$

$\infty)$  Answer: C

221)  $f(x) = \frac{(x+4)(x-4)}{x^2 - 16}$

A)  $(-\infty, \infty)$

C)  $(16, \infty)$

B)  $(-\infty, 16) \cup (16, \infty)$

D)  $(-\infty, -4) \cup (-4, 4) \cup (4, \infty)$

Answer: D

222)  $f(x) = \frac{(x+2)(x-2)}{x^2 + 4}$

A)  $(-\infty, -2) \cup (-2, 2) \cup (2, \infty)$

C)  $(-\infty, \infty)$

B)  $(4, \infty)$

D)  $(-\infty, 4) \cup (4,$

$\infty)$  Answer: C

223)  $H(x) = \frac{x}{\sqrt{x-10}}$

A)  $(-\infty, \infty)$

B)  $[10, \infty)$

C)  $(-\infty, 10) \cup (10, \infty)$

D)  $(10,$

$\infty)$  Answer: D

Use the vertical-line test to determine whether the graph represents a function.

224)

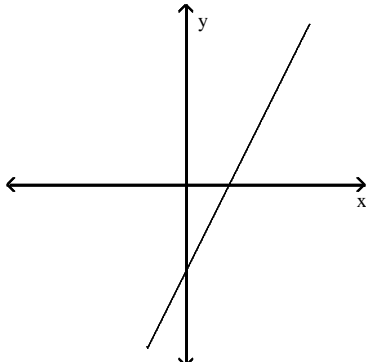

A) Yes

B) No

Answer: A

225)

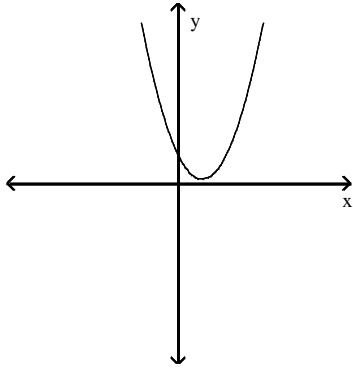

A) Yes

Answer: A

B) No

226)

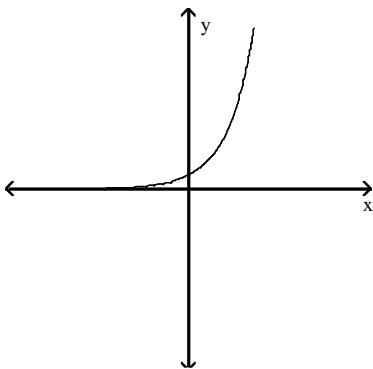

A) Yes

Answer: A

B) No

227)

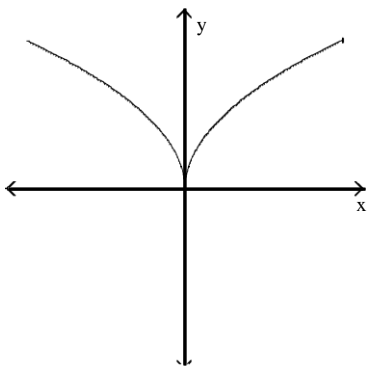

A) Yes

Answer: A

B) No

228)

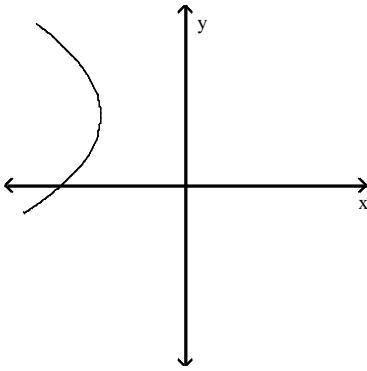

A) Yes

Answer: B

B) No

229)

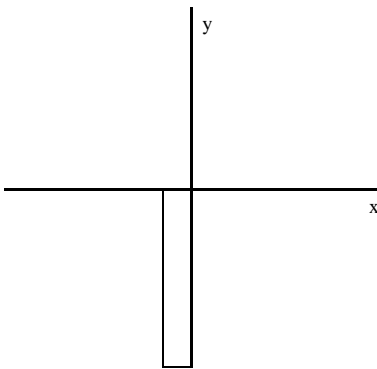

A) Yes

Answer: B

B) No

230)

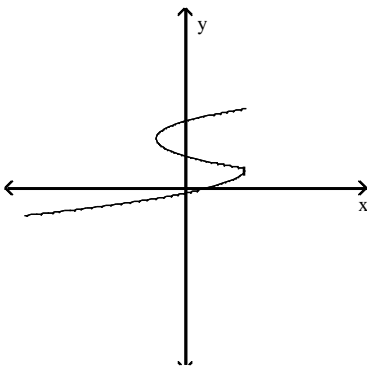

A) Yes

Answer: B

B) No

The graph of a function is given. Find the indicated function value.

231)  $f(2)$

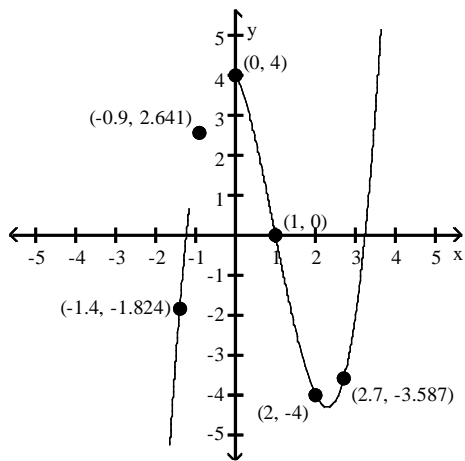

A) -4

B) 2.1

C) 1

D) -1.34

Answer: A

232)  $g(3)$

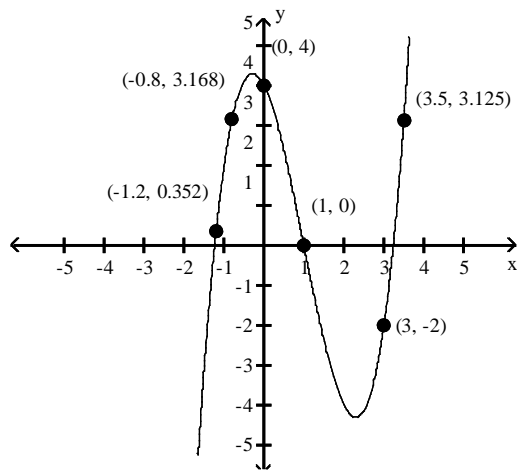

A) -2.5

B) -2

C) 4.238

D) 3

Answer: B



233)  $g(-2.2)$

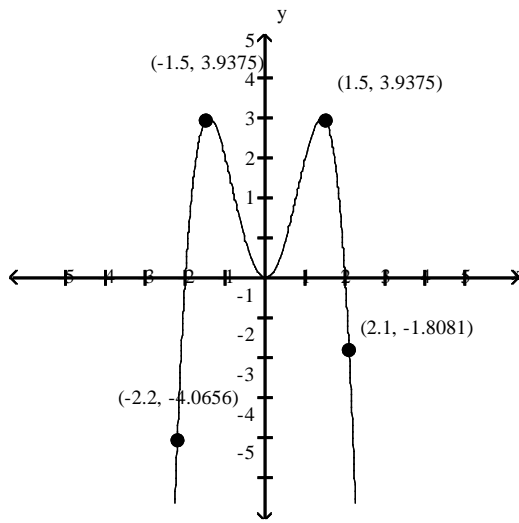

A) -4.0656

B) -1.8081

C) 2.2

D) 1.5

Answer: A

234)  $g(-2.4)$

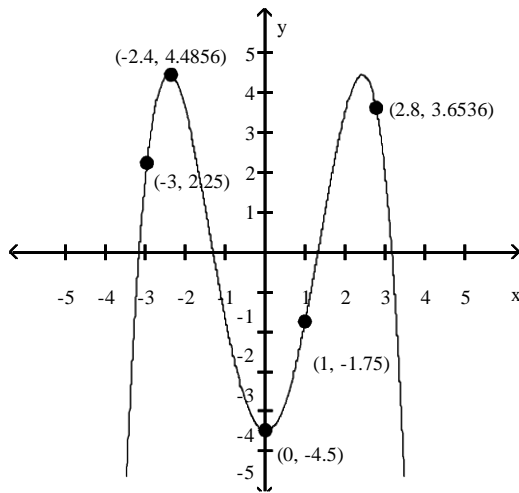

A) 2.4

B) 4.4856

C) -1.75

D) 1

Answer: B

235)  $f(1)$

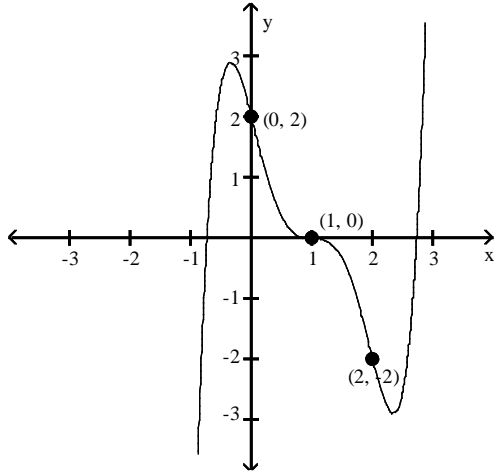

A) 2

B) 0

C) 1

D) -2

Answer: B

236)  $g(0)$

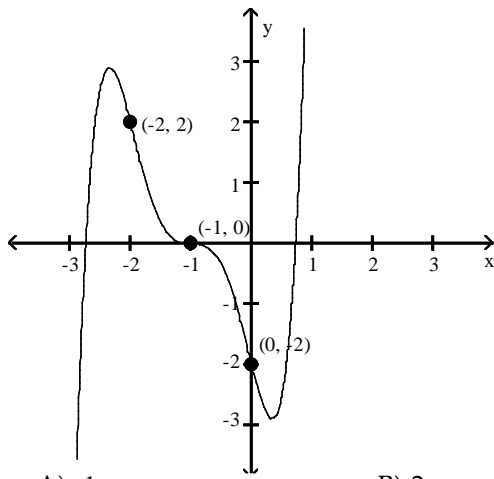

A) -1

B) 2

C) -2

D) 1

Answer: C

Solve the problem.

237) Let  $g(x) = x^2 - 2x - 27$ . Find  $x$  such that  $(x, 8)$  is on the graph of  $f(x)$ .

A)  $x = 7$

B)  $x = -5$  or  $7$

C) no solution

D)  $x = -7$  or  $5$

Answer: B

238) Let  $h(x) = x^2 + 2x + 8$ . Find  $x$  such that  $(x, 3)$  is on the graph of  $h(x)$ .

A) no solution

B)  $x = -2 \pm \sqrt{3}$

C)  $x = 2 \pm \sqrt{2}$

D)  $x = 0$

Answer: A

239) Let  $f(x) = 2(x - 4)^2 + 10$ . Find  $x$  such that  $(x, 14)$  is on the graph of  $f(x)$ .

A)  $x = -4 \pm \sqrt{2}$

B)  $x = 4 \pm \sqrt{2}$

C)  $x = 4 \pm \sqrt{3}$

D) no solution

Answer: B

240) Let  $H(x) = 2x^2 - 12x$ . Find  $x$  such that  $(x, -18)$  is on the graph of  $H(x)$ .

A) no solution

B)  $x = \pm 3$

C)  $x = -3$

D)  $x = 3$

Answer: D

SHORT ANSWER. Write the word or phrase that best completes each statement or answers the

question. Use the graph of the function to find the following:

- the domain and range of the function;
- the intercepts, if any;
- the indicated function values; and
- the value of  $x$  given the function value.

241)

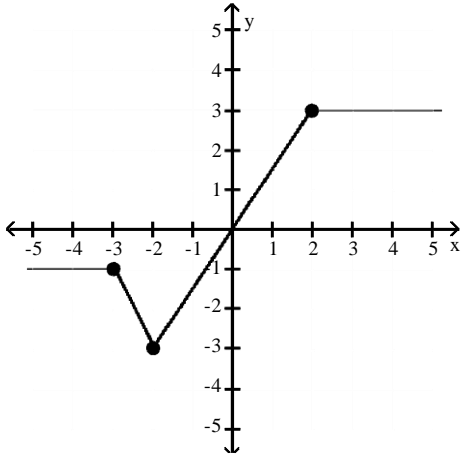

- Find  $f(-4)$ ,  $f(-2)$ , and  $f(2)$ .
- Solve  $f(x) = 3$ .

Answer: a. Domain:  $(-\infty, \infty)$ ; Range:  $[-3, 3]$

b. x-intercept: 0; y-intercept: 0

c.  $f(-4) = -1$ ,  $f(-2) = -3$ ,  $f(2) =$

3 d.  $[2, \infty)$

242)

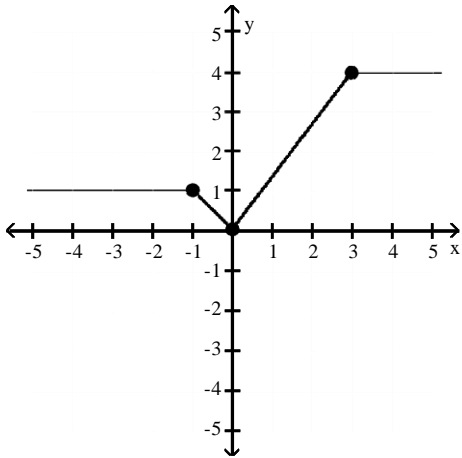

c. Find  $f(-4)$ ,  $f(0)$ , and  $f(4)$ . d. Solve  $f(x) = -2$ .

Answer: a. Domain:  $(-\infty, \infty)$ ; Range:  $[0, 4]$  b. x-intercept: 0; y-intercept: 0 c.  $f(-4) = 1$ ,  $f(0) = 0$ ,  $f(4) = 4$  d.  $\emptyset$

243)

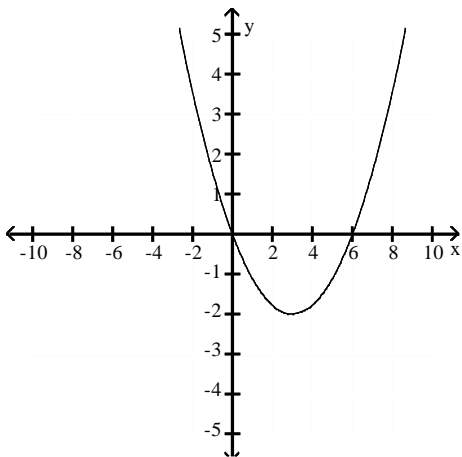

c. Find  $f(0)$  and  $f(6)$ . d. Solve  $f(x) = -4$ .

Answer: a. Domain:  $(-\infty, \infty)$ ; Range:  $[-2, \infty)$  b. x-intercepts: 0, 6; y-intercept: 0 c.  $f(0) = 0$ ,  $f(6) = 0$  d.  $\emptyset$

244)

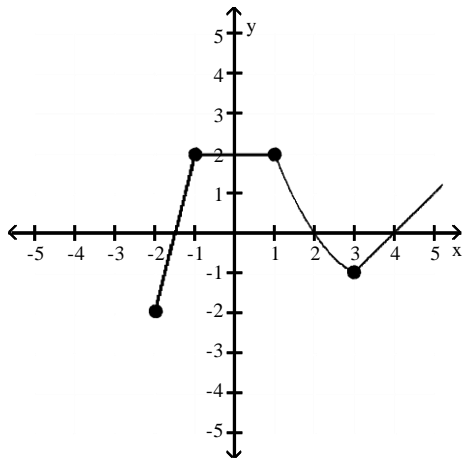

c. Find  $f(-2)$ ,  $f(1)$ , and  $f(3)$ . d. Solve  $f(x) = 2$ .

Answer: a. Domain:  $[-2, \infty)$ ; Range:  $[-2, \infty)$

b. x-intercepts:  $-\frac{3}{2}, 2, 4$ ; y-intercept: 2

c.  $f(-2) = -2$ ,  $f(1) = 2$ ,  $f(3) = -1$

d.  $[-1, 1]$

245)

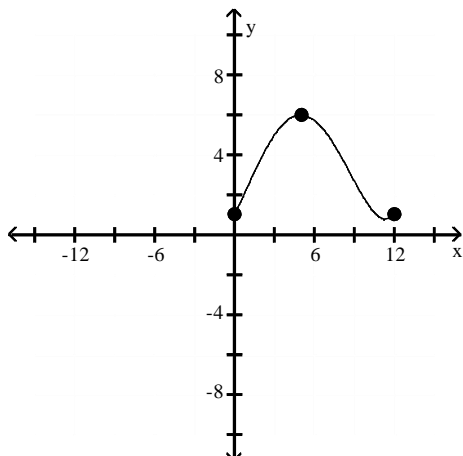

c. Find  $f(0)$ ,  $f(1)$ , and  $f(12)$ .

d. Solve  $f(x) = 6$ .

Answer: a. Domain:  $[0, 12]$ ; Range:  $[1, 6]$

b. x-intercept: none; y-intercept: 1

c.  $f(0) = 1$ ,  $f(1) = 2$ ,  $f(12) = 1$

d.  $\{5\}$

MULTIPLE CHOICE. Choose the one alternative that best completes the statement or answers the question. State whether the given relation is a function.

246) Consider the relation whose domain is all students attending Laughlin Community College and whose range values are a set of the students' Social Security numbers. Is this relation a function?

A) Yes

B) No

Answer: A

- 247) Consider a relation whose domain is all students attending the University of Ohio and whose range values are a set of each students' teachers. Is this relation a function?  
 A) Yes B) No

Answer: B

- 248) Is a function generated in the process of choosing teams from a group of 32 students by counting them off in fours; for example: "1, 2, 3, 4, 1, 2, 3, 4, 1, 2, ..."?  
 A) Yes B) No

Answer: B

Solve the problem.

- 249) A formula relating an athlete's vertical leap  $V$ , in inches, to hang time  $t$ , in seconds, is  $V(t) = 48t^2$ . A professional basketball player has a vertical leap of 40 inches. What is his hang time? Round your answer to the nearest tenth of a second.  
 A) 0.8 sec B) 0.6 sec C) 0.9 sec D) 1 sec

Answer: C

- 250) A stone thrown downward with an initial velocity of 34.3 m/sec will travel a distance of  $s$  meters, where

$s(t) = 4.9t^2 + 34.3t$  and  $t$  is in seconds. If a stone is thrown downward at 34.3 m/sec from a height of 294 m, how long will it take the stone to hit the ground? Round your answer to the nearest second.

- A) 5 sec B) 12 sec C) 17 sec D) 7 sec

Answer: A

- 251) If there are  $x$  teams in a sports league and all the teams play each other twice, a total of  $N(x)$  games are played, where  $N(x) = x^2 - x$ . A soccer league has 10 teams, each of which plays the others twice. If the league pays \$44 per game for the field and officials, how much will it cost to play the entire schedule?  
 A) \$4840 B) \$3960 C) \$4048 D) \$4400

Answer: B

- 252) Under certain conditions, the power  $P$ , in watts per hour, generated by a windmill with winds blowing  $v$  miles per hour is given by  $P(v) = 0.015v^3$ . Find the power generated by 18-mph winds.  
 A) 4.86 watts per hr B) 87.48 watts per hr  
 C) 5832 watts per hr D) 0.00006075 watts per hr

Answer: B

- 253) Assume that a person's threshold weight  $W$ , defined as the weight above which the risk of death rises dramatically, is given by  $W(h) = \left(\frac{h}{12.3}\right)^3$ , where  $W$  is in pounds and  $h$  is the person's height in inches. Find the

threshold weight for a person who is 6 ft 8 in. tall. Round your answer to the nearest pound.

- A) 221.5 lb B) 307.3 lb C) 169 lb D) 275.1 lb

Answer: D

- 254) The function,  $S(x) = 0.0044x^4 + 0.0039x^3 + 0.0042x^2 + 0.13x + 1.5$ , gives the predicted sales volume of a company, in millions of items, where  $x$  is the number of years from now. Determine the predicted sales 12 years from now. Round your answer to two decimals, if necessary.

- A) 86.89 million B) 157.76 million C) 101.64 million D) 104.77 million

Answer: C





258)

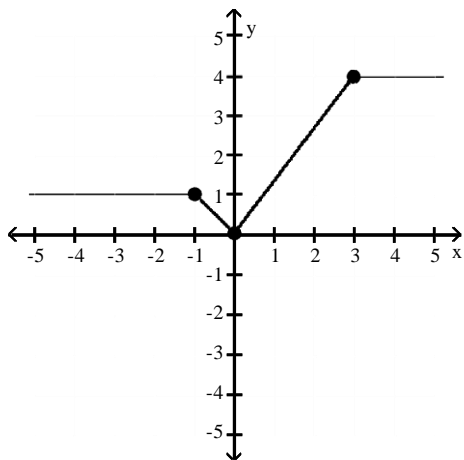

- Answer: a. Domain:  $(-\infty, \infty)$ ; Range:  $[0;4]$   
b. x-intercept: 0; y-intercept: 0  
c. constant on  $(-\infty, -1)$ , decreasing on  $(-1, 0)$ , increasing on  $(0, 3)$ , constant on  $(3, \infty)$   
d. Neither even nor odd.

259)

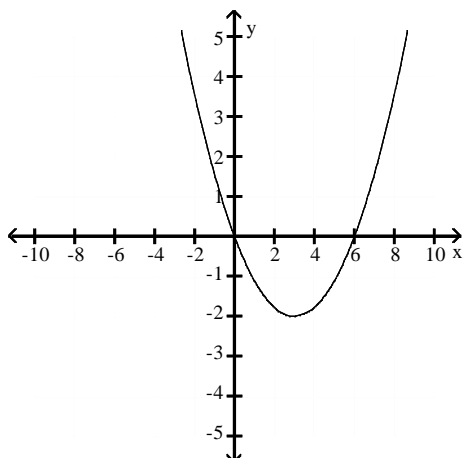

- Answer: a. Domain:  $(-\infty, \infty)$ ; Range:  $[-2, \infty)$   
b. x-intercepts: 0, 6; y-intercept: 0  
c. decreasing on  $(-\infty, 3)$ , increasing on  $(3, \infty)$   
d. Neither even nor odd.

260)

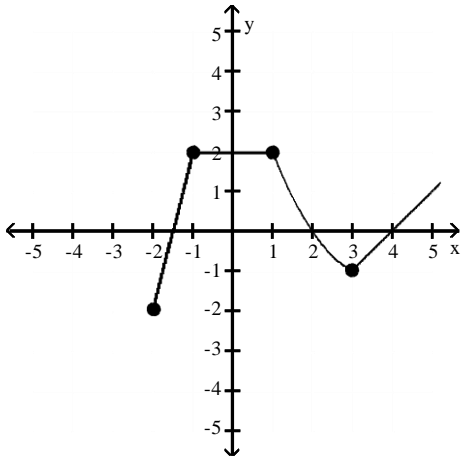

Answer: a. Domain:  $[-2, \infty)$ ; Range:  $[-2, \infty)$

b. x-intercepts:  $-\frac{3}{2}, 2, 4$ ; y-intercept: 2

c. increasing on  $(-2, -1)$ , constant on  $(-1, 1)$ , decreasing on  $(1, 3)$ , increasing on  $(3, \infty)$

d. Neither even nor odd.

261)

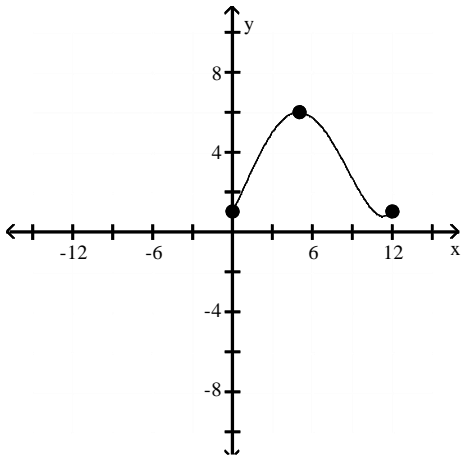

Answer: a. Domain:  $[0, 12]$ ; Range:  $[1, 6]$

b. x-intercept: none; y-intercept: 1

c. increasing on  $(0, 5)$ , decreasing on  $(5, 12)$

d. Neither even nor odd.

MULTIPLE CHOICE. Choose the one alternative that best completes the statement or answers the question.

Locate relative maximum and relative minimum points on the graph. State whether each relative extremum point is a turning point.

262)

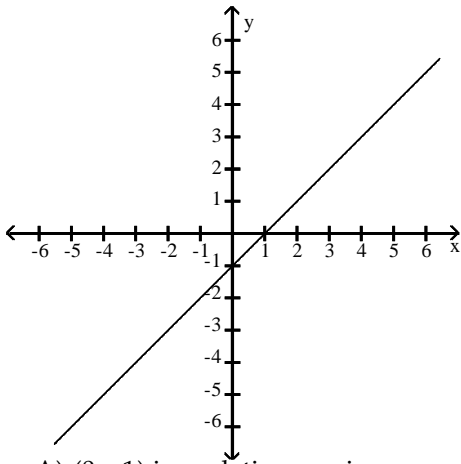

- A)  $(0, -1)$  is a relative maximum.
- C)  $(0, -1)$  is a relative minimum.

- B) No relative extrema.
- D)  $(-1, 0)$  is a relative minimum.

Answer: B

263)

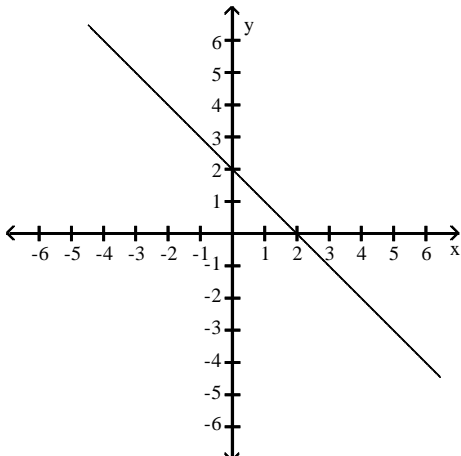

- A)  $(0, 2)$  is a relative minimum.
- C)  $(2, 0)$  is a relative minimum.

- B) No relative extrema.
- D)  $(2, 0)$  is a relative maximum.

Answer: B

264)

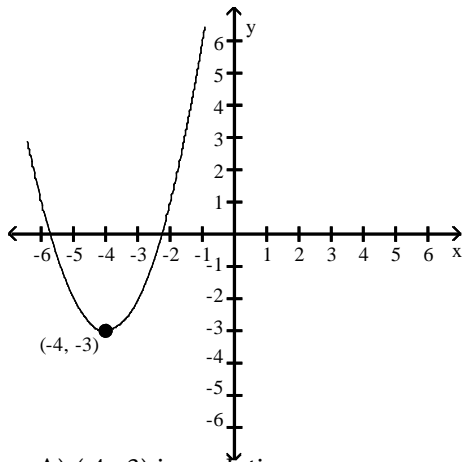

A)  $(-4, -3)$  is a relative maximum. B) No relative extrema.

C)  $(-4, -3)$  is a relative minimum and a turning point.  $(0, 0)$  is a relative maximum. D)  $(-4, -3)$  is a relative minimum and a turning point.

Answer: D

265)

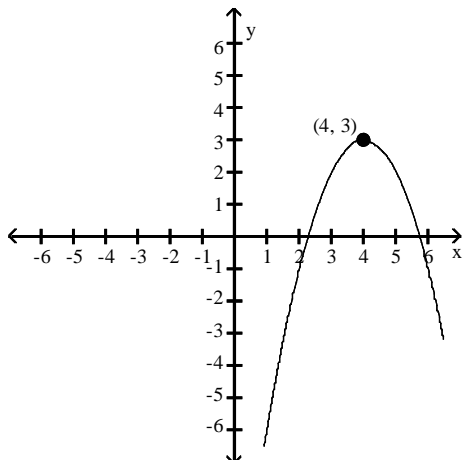

A)  $(4, 0)$  is a relative maximum.

B) No relative extrema.

C)  $(4, 3)$  is a relative minimum and a turning point.

D)  $(4, 3)$  is a relative maximum and a turning point.

Answer: D

266)

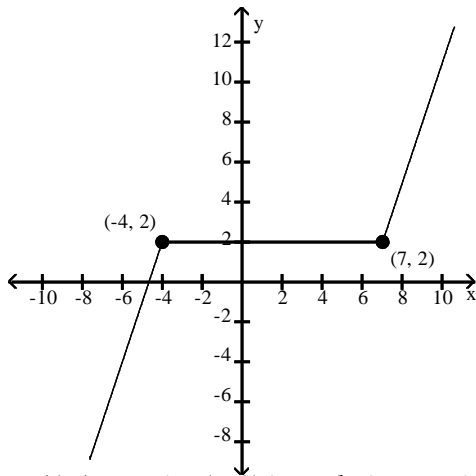

- A) Any point  $(x, 2)$  is a relative maximum and a relative minimum point on the interval  $(-4, 7)$ ; both  $(-4, 2)$  and  $(7, 2)$  are turning points.
- B) Any point  $(x, 2)$  is a relative maximum and a relative minimum point on the interval  $(-4, 7)$ ; none of these points are turning points.
- C)  $(-4, 2)$  and  $(7, 2)$  are relative maxima and minima points; neither of these points are turning points
- D)  $(-4, 2)$  and  $(7, 2)$  are relative maxima and minima points; both of these points are turning points

Answer: B

267)

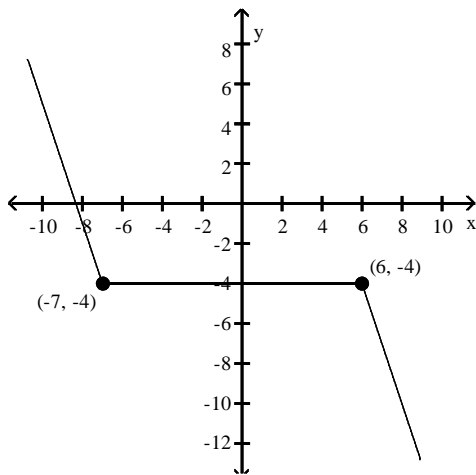

- A)  $(-7, -4)$  and  $(6, -4)$  are relative maxima and minima points; neither of these points are turning points
- B)  $(-7, -4)$  and  $(6, -4)$  are relative maxima and minima points; both of these points are turning points
- C) Any point  $(x, -4)$  is a relative maximum and a relative minimum point on the interval  $(-7, 6)$ ; both  $(-7, -4)$  and  $(6, -4)$  are turning points.
- D) Any point  $(x, -4)$  is a relative maximum and a relative minimum point on the interval  $(-7, 6)$ ; none of these points are turning points.

Answer: D

268)

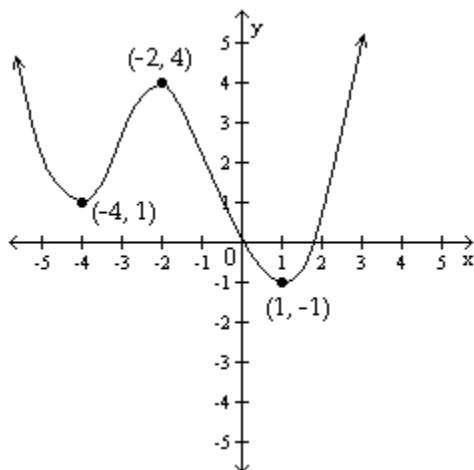

- A)  $(-2, 4)$  is a relative maximum and a turning point.  $(-4, 1)$  is a relative minimum point and a turning point. B)  $(-2, 4)$  is a relative maximum point and a turning point.  $(1, -1)$  is a relative minimum point and a turning point.  
C)  $(-2, 4)$  is a relative maximum.  $(-4, 1)$  and  $(1, -1)$  are relative minima points.  
D)  $(-2, 4)$  is a relative maximum point and a turning point.  $(-4, 1)$  and  $(1, -1)$  are relative minima points and turning points.

Answer: D

269)

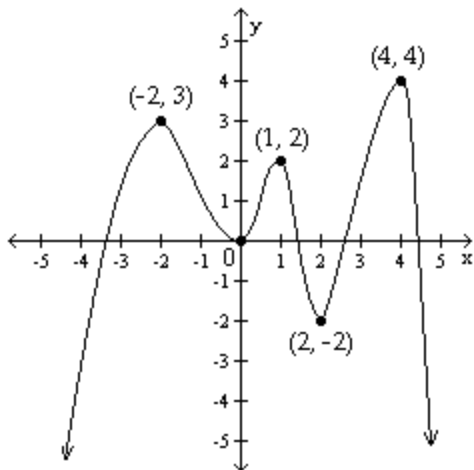

- A)  $(-2, 3)$ ,  $(1, 2)$ , and  $(4, 4)$  are relative maxima points and turning points.  $(0, 0)$  and  $(2, -2)$  are relative minima points and turning points.  
B)  $(-2, 3)$ ,  $(1, 2)$ , and  $(4, 4)$  are relative maxima points.  $(0, 0)$  and  $(2, -2)$  are relative minima points.  
C)  $(-2, 3)$ ,  $(1, 2)$ , and  $(4, 4)$  are relative maxima points and turning points.  $(2, -2)$  is a relative minimum point and a turning point.  
D)  $(4, 4)$  is a relative maximum point and a turning point.  $(2, -2)$  is a relative minimum point and a turning point.

Answer: A

Determine whether the given function is even, odd, or neither.

270)  $f(x) = 2x^2 - 5$

A) Even

B) Odd

C) Neither

Answer: A

271)  $f(x) = -9x^5 - 4x^3$

A) Even

B) Odd

C) Neither

Answer: B

272)  $f(x) = -5x^4 - 6x + 9$

A) Even

B) Odd

C) Neither

Answer: C

273)  $f(x) = -4$

A) Even

B) Odd

C) Neither

Answer: A

274)  $f(x) = \frac{1}{x}$

A) Even

B) Odd

C) Neither

Answer: A

275)  $f(x) = \frac{x}{x^2 + 4}$

A) Even

B) Odd

C) Neither

Answer: B

276)  $f(x) = \frac{-x^3}{2x^2 + 7}$

A) Even

B) Odd

C) Neither

Answer: B

277)

|      |       |     |       |   |       |     |   |
|------|-------|-----|-------|---|-------|-----|---|
| x    | -3    | -2  | -1    | 0 | 1     | 2   | 3 |
| f(x) | -21.8 | -19 | -5.02 | 5 | -5.02 | -19 | - |

A) Even

B) Odd

C) Neither

Answer: A

Find the average rate of change of the function as x changes from a to b.

278)  $f(x) = -6x + 7$ ; a = 1, b = 4

A) 6

B) -6

C) 0

D)  $\frac{1}{6}$

Answer: B

279)  $g(x) = 3x - 8$ ; a = -2, b = 1

A) 3

B) 0

C) -3

D)  $\frac{1}{3}$

Answer: A

280)  $h(x) = 4x^2$ ;  $a = 3$ ,  $b = 4$   
 A) 4                                      B) 28                                      C) -28                                      D) -4  
 Answer: B

281)  $f(x) = x^2 - 5$ ;  $a = -1$ ,  $b = 2$   
 A) 1                                      B) 0                                      C) -1                                      D) -3  
 Answer: A

282)  $g(x) = 4 - x^2$ ;  $a = -1$ ,  $b = 5$   
 A) 4                                      B) -6                                      C) 6                                      D) -4  
 Answer: D

283)  $h(x) = (7 - x)^2$ ;  $a = 3$ ,  $b = 4$   
 A) -7                                      B) 0                                      C) -15                                      D) 21  
 Answer: A

284)  $g(x) = (x - 3)^2$ ;  $a = 1$ ,  $b = 5$   
 A) -10                                      B) 0                                      C) 12                                      D) 2  
 Answer: B

285)  $f(x) = -x^3$ ;  $a = -1$ ,  $b = 2$   
 A) 7                                      B) 3                                      C) -5                                      D) -3  
 Answer: D

286)  $h(x) = \frac{3}{3x}$ ;  $a = -2$ ,  $b =$   
 A)  $\frac{1}{2}$                                       B)  $-\frac{1}{2}$                                       C)  $\frac{3}{2}$                                       D) 0  
 Answer: A

287)  $g(x) = \frac{1}{x+2}$ ;  $a = 2$ ,  $b = 5$   
 A)  $-\frac{1}{28}$                                       B)  $-\frac{1}{14}$                                       C)  $\frac{3}{28}$                                       D)  $\frac{1}{28}$   
 Answer: A

Compute  $\frac{f(x+h) - f(x)}{h}$  ( $h \neq 0$ ) for the given function.

288)  $f(x) = 3x - 6$   
 A) 3                                      B) 2                                      C)  $-3h$                                       D) 6  
 Answer: A

289)  $f(x) = 3x^2 + 7x$   
 A)  $6x + 7$   
 B)  $6x^2 + 3h + 7x$                                       C)  $6x + 3h + 7$                                       D)  $9x - 5h +$   
 14  
 Answer: C



290)  $f(x) = \frac{1}{4x}$

A)  $\frac{-1}{4x(x+h)}$

B)  $\frac{1}{4x}$

C) 0

D)  $\frac{-1}{x(x+h)}$

Answer: A

Use the accompanying graph of a particle moving on a coordinate line with velocity  $v = f(t)$  in ft/sec at time  $t$  seconds. The axes are marked off at one-unit intervals. Use these terms to describe the motion state: moving forward/backward, increasing/decreasing speed, and resting. Recall that speed = velocity.

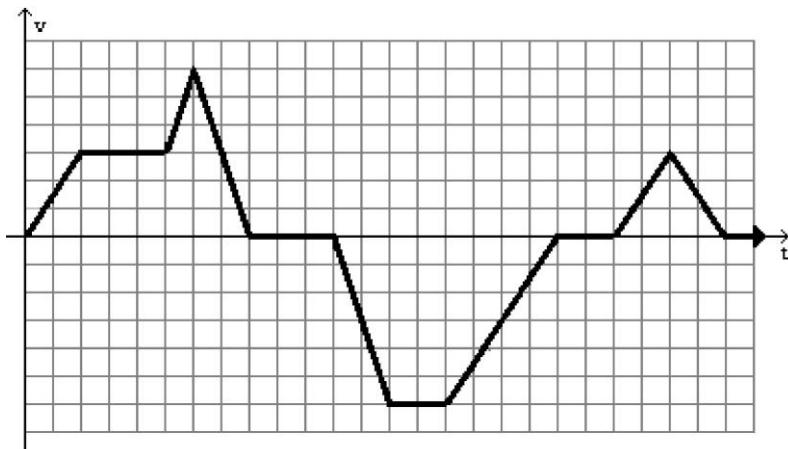

291) Give the interval(s) when the particle is moving forward.

A) (11, 19)  
25)

B) (8, 11) and (19, 21)

C) (0, 8) and (21, 25)

D) (0, 11) and (19,

Answer: C

292) Give the interval(s) when the particle is moving backward.

A) (8, 11) and (19, 21)

B) (8, 21)

C) (0, 8) and (21, 25)

D) (11, 19)

Answer: D

293) Give the interval(s) when the particle is at rest.

A) (11, 19)

C) (8, 11), (19, 21), and (25, 26)

B) The particle is never at rest.

D) (8, 21)

Answer: C

294) Give the interval(s) when the speed of the particle is increasing.

A) (0, 6), (11, 15), and (19, 23)

C) (0, 2), (5, 6), (11, 13), and (21, 23)

B) (0, 2), (5, 6), and (21, 23)

D) (0, 2), (5, 6), and (11, 13)

Answer: C

295) Give the interval(s) when the speed of the particle is decreasing.

A) (6, 8), (15, 19), and (23, 25)

C) (6, 11), (15, 17), and (23, 25)

B) (6, 11), (15, 21), and (23, 25)

D) (6, 8), (11, 19), and (23,

25) Answer: A

Solve the problem.

296) A salesperson gets a commission of \$1400 for the first \$10,000 of sales, and then \$700 for each additional \$10,000 or partial of sales. Let  $S(x)$  represent the commission on  $x$  dollars of sales. Find the value of  $S(85,000)$ .

- A) \$5950                                      B) \$6650                                      C) \$7350                                      D) \$7000

Answer: D

297) The cost of manufacturing a molded part is related to the quantity of parts produced during a production run.

When 100 parts are produced, the cost is \$300. When 500 parts are produced, the cost is \$1900. What is the average cost per part?

- A) \$3.20 per part                                      B) \$5.00 per part                                      C) \$0.25 per part                                      D) \$4.00 per part

Answer: D

298) A rectangular piece of cardboard measuring 17 inches by 39 inches is to be made into a box with an open top by cutting equal size squares from each corner and folding up the sides. Let  $x$  represent the length of a side of each such square. For what value of  $x$  will the volume be a maximum? If necessary, round to 2 decimal places.

- A) 29.96 in.                                      B) 17.62 in.                                      C) 3.69 in.                                      D) 14.98 in.

Answer: C

299) John owns a hotdog stand. He has found that his profit is represented by the equation  $P = -x^2 + 76x + 86$ , with  $P$

being profits and  $x$  the number of hotdogs. How many hotdogs must he sell to earn the most profit?

- A) 48 hotdogs                                      B) 24 hotdogs                                      C) 39 hotdogs                                      D) 38 hotdogs

Answer: D

300) Bob owns a watch repair shop. He has found that the cost of operating his shop is given by  $c(x) = 3x^2 - 162x + 82$ , where  $x$  is the number of watches repaired. How many watches must he repair to have the lowest cost?

- A) 41 watches                                      B) 30 watches                                      C) 82 watches                                      D) 27 watches

Answer: D

301) April shoots an arrow upward into the air at a speed of 32 feet per second from a platform that is 10 feet high.

The height of the arrow is given by the function  $h(t) = -16t^2 + 32t + 10$ , where  $t$  is the time in seconds. What is the maximum height of the arrow?

- A) 16 ft                                      B) 10 ft                                      C) 26 ft —                                      D) 9 ft —

Answer: C

Write a linear function  $f$  that has the indicated values.

302)  $f(7) = -3, f(0) = -7$

- A)  $f(x) = \frac{4}{7}x - 7$                                       B)  $f(x) = \frac{10}{7}x - 7$                                       C)  $f(x) = -\frac{10}{7}x - 7$                                       D)  $f(x) = -\frac{4}{7}x - 7$

Answer: A

303)  $f(-9) = 0, f(5) = -3$

- $\frac{9}{3} \quad \frac{21}{27}$                                        $\frac{9}{9} \quad \frac{21}{21}$                                        $\frac{3}{3} \quad \frac{27}{27}$

$$A) f(x) = \frac{1}{14}x - \frac{1}{14}$$

+

$$B) f(x) = \frac{1}{8}x - \frac{1}{8}$$

$$C) f(x) = \frac{1}{8}x + \frac{1}{8}$$

$$D) f(x) = -\frac{1}{14}x - \frac{1}{14}$$

Answer: D

304)  $f(-6) = 2, f(-9) = -5$

A)  $f(x) = -\frac{7}{3}x + 16$

B)  $f(x) = \frac{7}{3}x + 16$

C)  $f(x) = 2x + 13$

D)  $f(x) = -2x + 13$

Answer: B

305)  $f(2) = -9, f(-1) = 8$

A)  $f(x) = -\frac{17}{3}x + \frac{7}{3}$

B)  $f(x) = \frac{11}{9}x + \frac{61}{9}$

C)  $f(x) = \frac{17}{3}x + \frac{7}{3}$

D)  $f(x) = -\frac{11}{9}x + \frac{61}{9}$

Answer: A

306)  $f(0) = -3, f(7) = 0$

A)  $f(x) = -\frac{3}{7}x - 3$

B)  $f(x) = \frac{3}{7}x - 3$

C)  $f(x) = \frac{7}{3}x + 7$

D)  $f(x) = \frac{7}{3}x + 7$

Answer: B

Find the requested value.

307) Find  $f(5)$  for

$$f(x) = \begin{cases} 5, & \text{if } x < 3 \\ -5, & \text{if } x > 3 \end{cases}$$

A) undefined

B) 5

C) -25

D) -5

Answer: D

308) Find  $f(-9)$  for

$$f(x) = \begin{cases} 4x, & \text{if } x \leq -1 \\ x - 4, & \text{if } x > -1 \end{cases}$$

A) -13

B) 5

C) 36

D) -36

Answer: D

309) Find  $f(0)$  for

$$f(x) = \begin{cases} x - 8, & \text{if } x < 4 \\ 3 - x, & \text{if } x \geq 4 \end{cases}$$

A) -8

B) -1

C) -4

D) 3

Answer: A

Graph the function.

310)  $f(x) = \begin{cases} 7 & \text{if } x > 1 \\ -7 & \text{if } x \leq 1 \end{cases}$

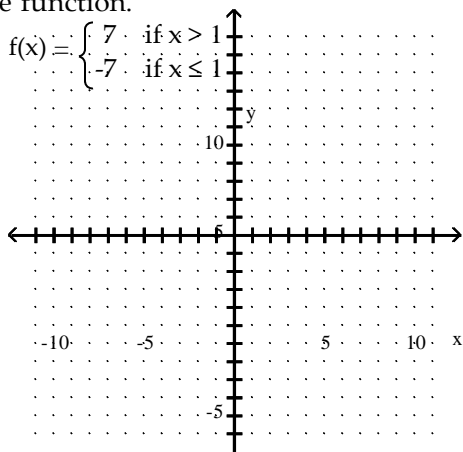

A)

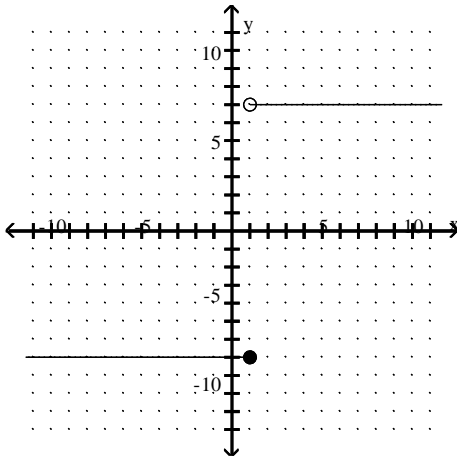

B)

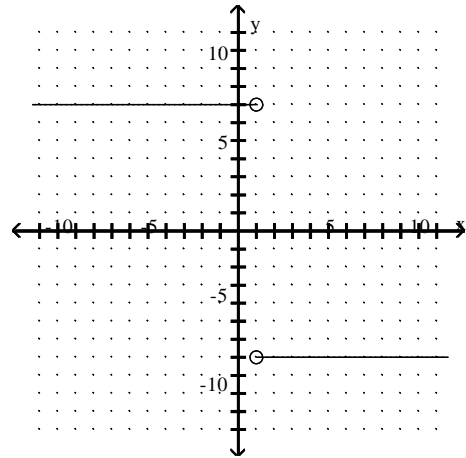

C)

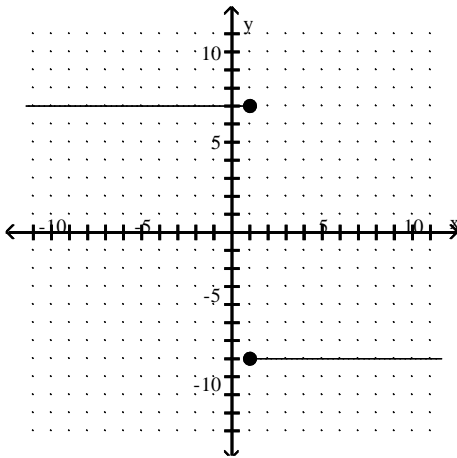

D)

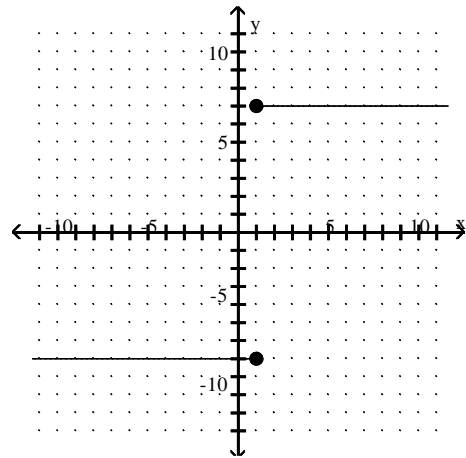

Answer: A

$$311) f(x) = \begin{cases} x + 4 & \text{if } x > 0 \\ -5 & \text{if } x \leq 0 \end{cases}$$

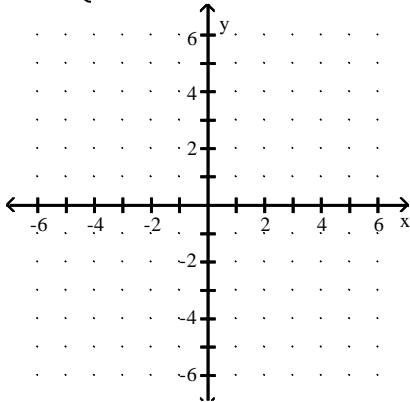

A)

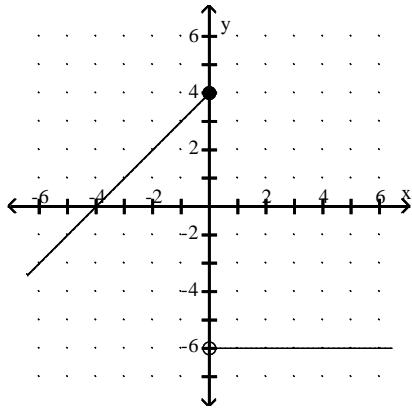

B)

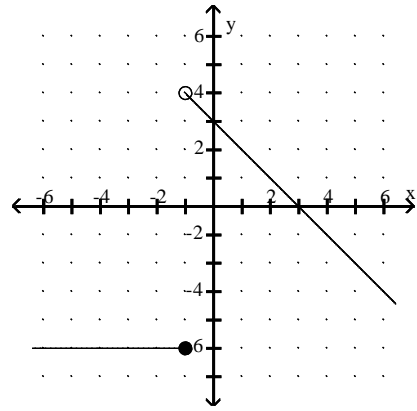

C)

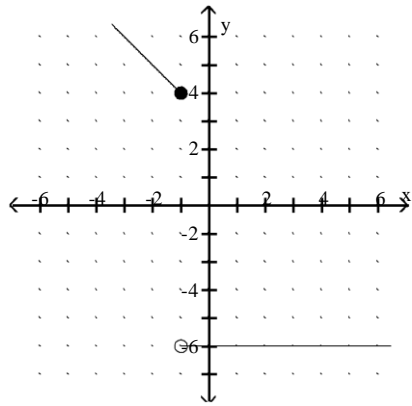

D)

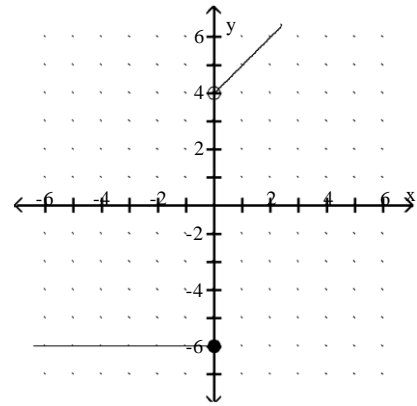

Answer: D

$$312) f(x) = \begin{cases} -2 & \text{if } x \geq 1 \\ -4 - x & \text{if } x < 1 \end{cases}$$

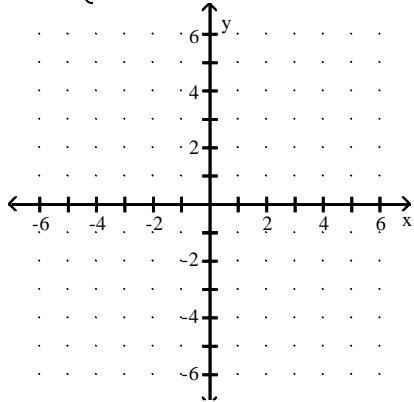

A)

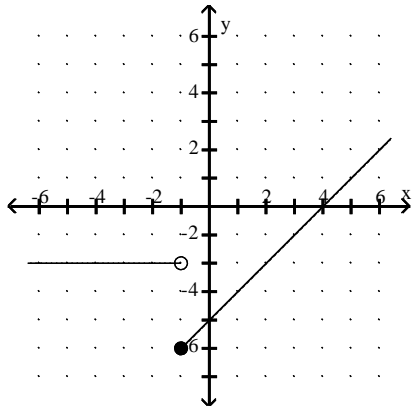

B)

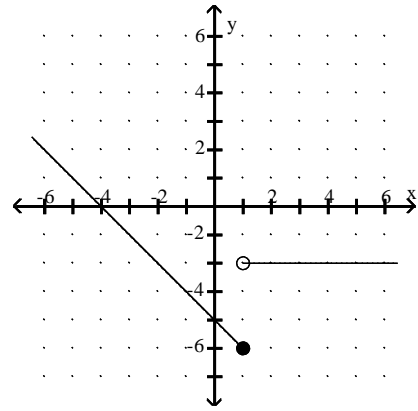

C)

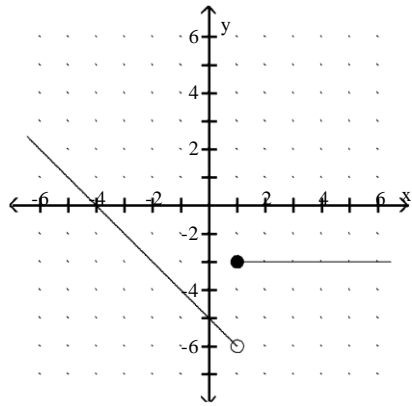

D)

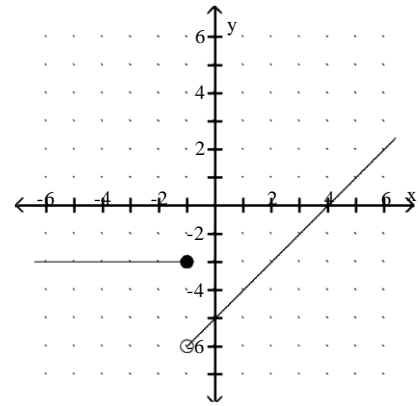

Answer: C

$$313) f(x) = \begin{cases} |x| & \text{if } x \leq 1 \\ x^2 & \text{if } x > 1 \end{cases}$$

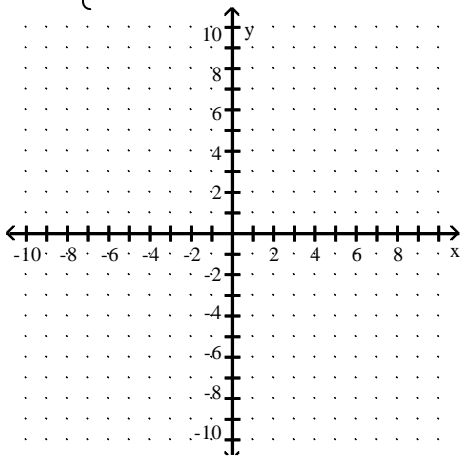

A)

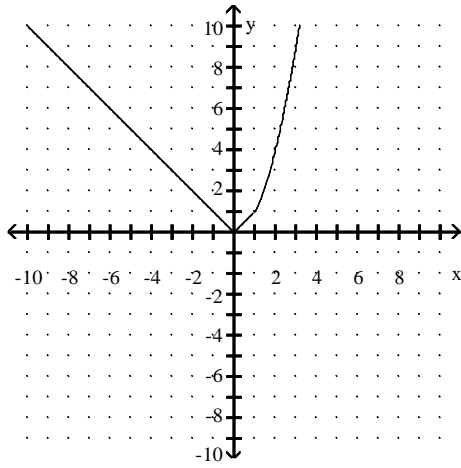

B)

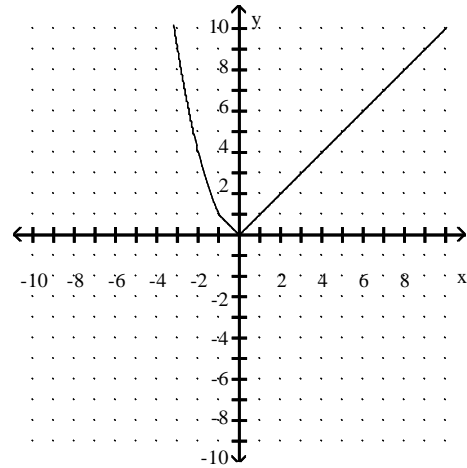

C)

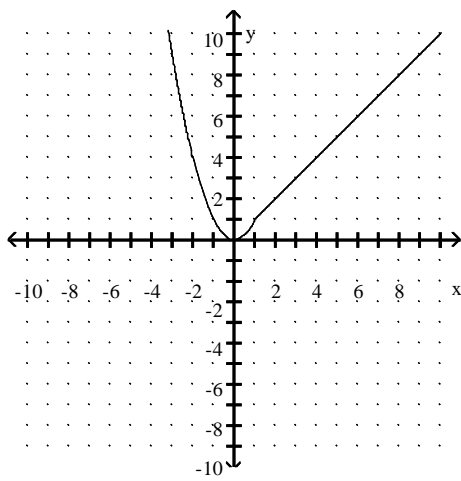

D)

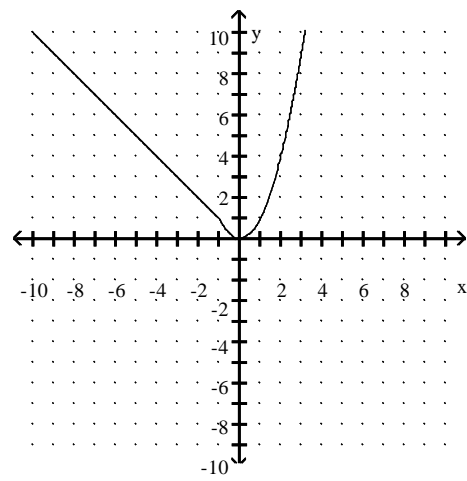

Answer: A

$$314) f(x) = \begin{cases} |x| & \text{if } x \leq -2 \\ x^2 & \text{if } x > -2 \end{cases}$$

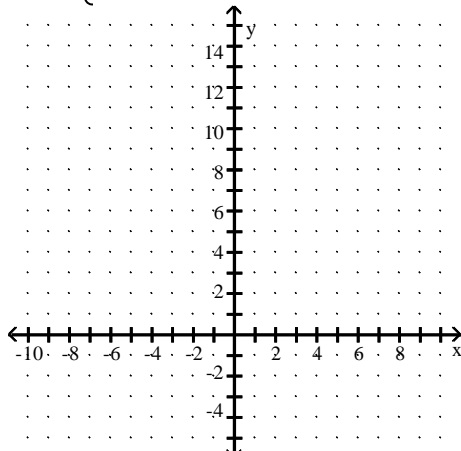



A)

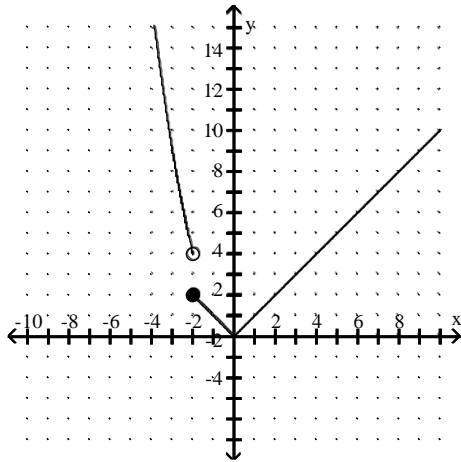

B)

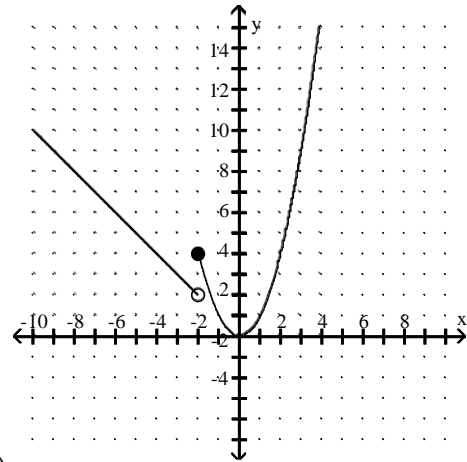

C)

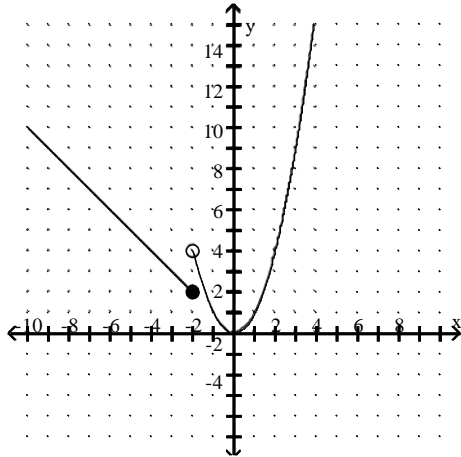

D)

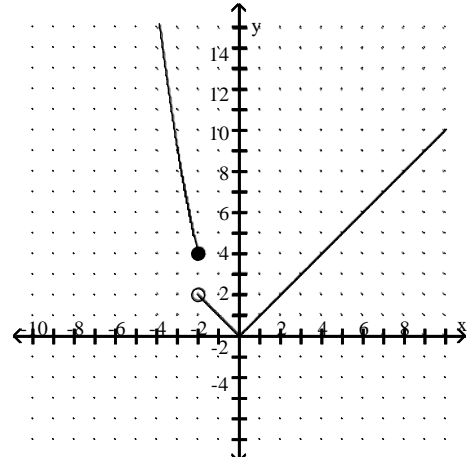

Answer: C

$$315) f(x) = \begin{cases} x^3 & \text{if } x \leq 1 \\ \sqrt[3]{x} & \text{if } x > 1 \end{cases}$$

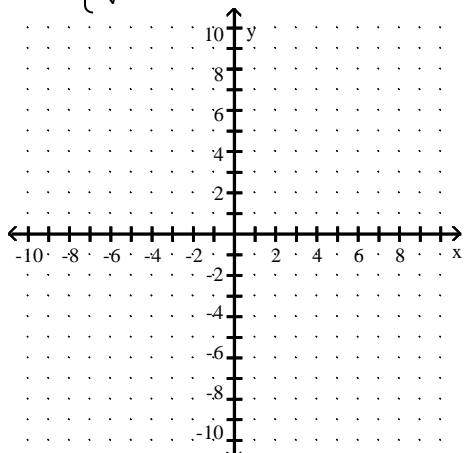

A)

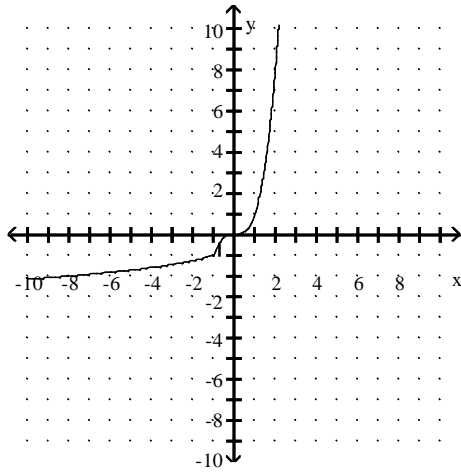

B)

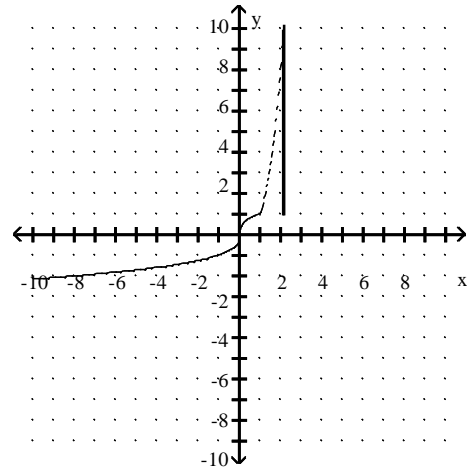

C)

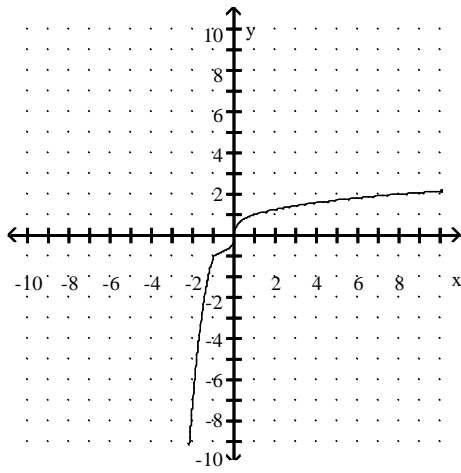

D)

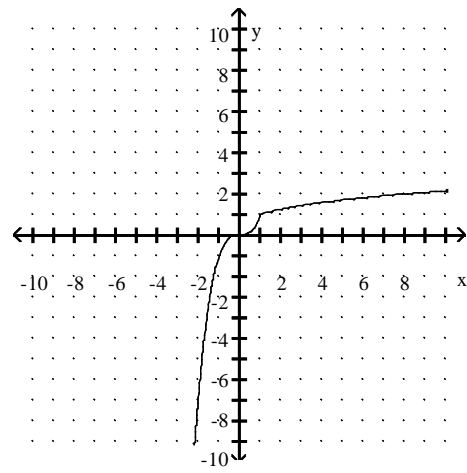

Answer: D

$$316) f(x) = \begin{cases} x^2 & \text{if } -1 < x \leq 3 \\ 3x & \text{if } x > 3 \end{cases}$$

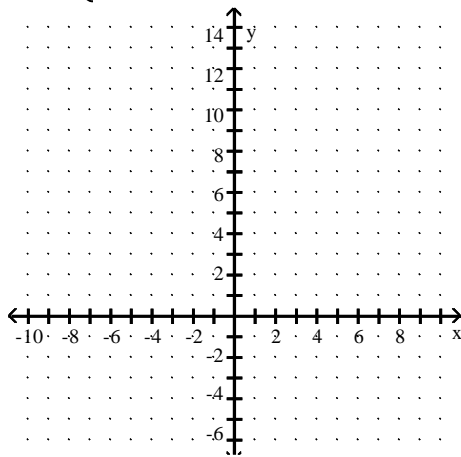

A)

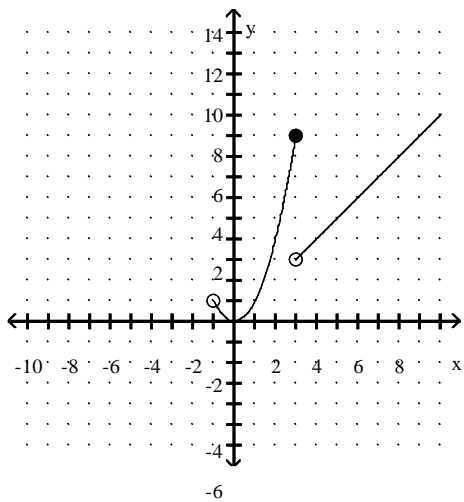

B)

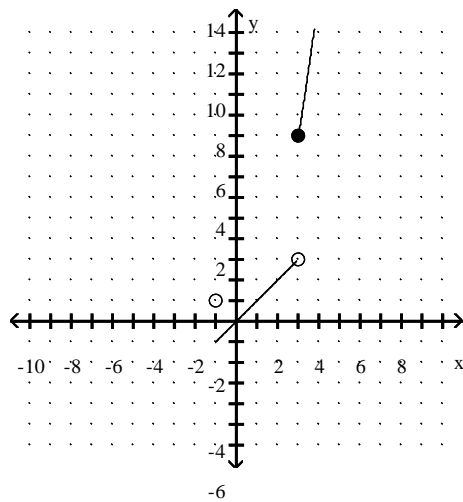

C)

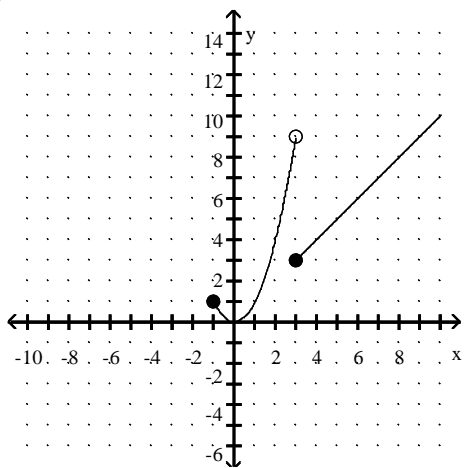

D)

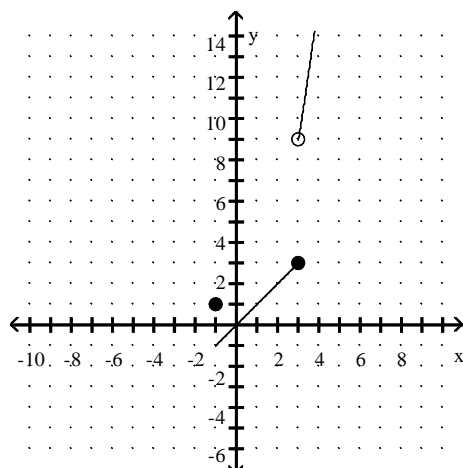

Answer: A

$$317) f(x) = \begin{cases} |x| & \text{if } x \leq 0 \\ x^2 & \text{if } 0 < x \leq 3 \end{cases}$$

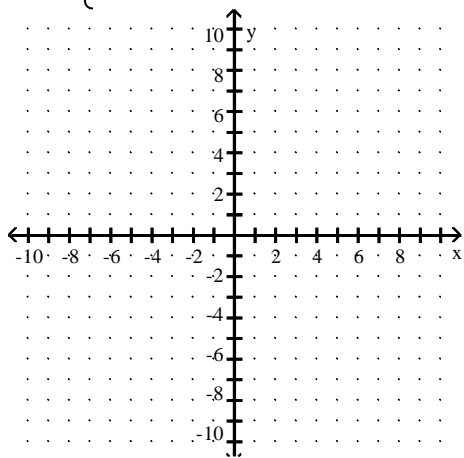

A)

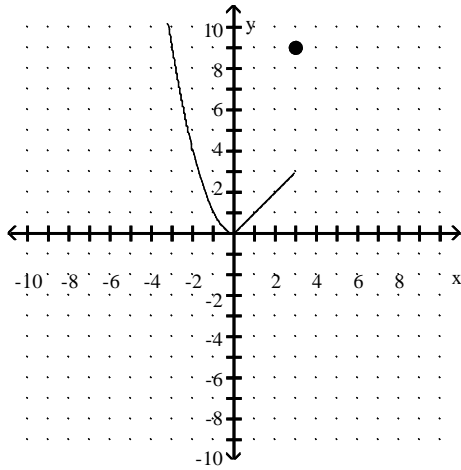

B)

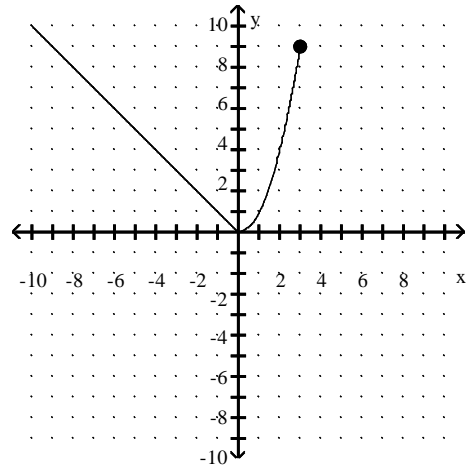

C)

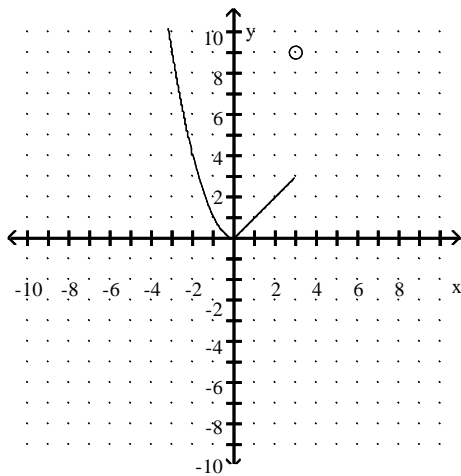

D)

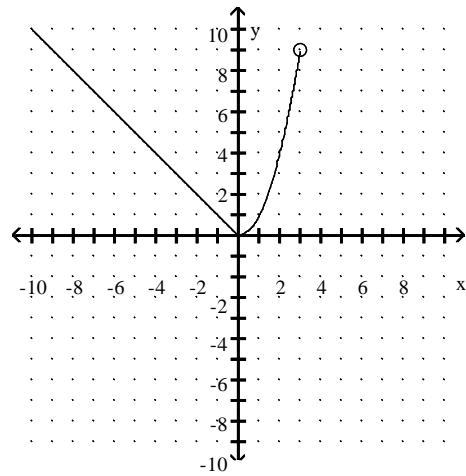

Answer: B

Solve the problem.

318) If an object is dropped off of a tower, the velocity,  $V$ , of the object after  $t$  seconds can be obtained by multiplying  $t$  by 32 and adding 10 to the result. Express  $V$  as a linear function of  $t$ .

- A)  $V(t) = 32t + 10$       B)  $V(t) = 32 + 10t$       C)  $V(t) = \frac{t-10}{32}$       D)  $V(t) = 42t$

Answer: A

319) If an object is dropped from a tower, then the velocity,  $V$  (in feet per second), of the object after  $t$  seconds can be obtained by multiplying  $t$  by 32 and adding 10 to the result. Find  $V$  as a linear function of  $t$ , and use this

function to evaluate  $V(3.2)$ , the velocity of the object at time  $t = 3.2$  seconds.

- A)  $V(3.2) = 113.7$  ft/sec      B)  $V(3.2) = 110.4$  ft/sec  
 C)  $V(3.2) = 111.7$  ft/sec      D)  $V(3.2) = 112.4$  ft/sec

Answer: D

320) Assume that the sales of a certain appliance dealer are approximated by a linear function. Suppose that sales were \$5500 in 1982 and \$86,500 in 1987. Let  $x = 0$  represent 1982. Find the equation giving yearly sales  $S(x)$ .

- A)  $S(x) = 16,200x + 5500$       B)  $S(x) = 16,200x + 86,500$

C)  $S(x) = 81,000x + 86,500$

D)  $S(x) = 81,000x + 5500$

Answer: A

321) The charges for renting a moving van are \$75 for the first 40 miles and \$7 for each additional mile. Assume that a fraction of a mile is rounded up. Find a symbolic representation for a function  $f$  that computes the cost of driving the van  $x$  miles, where  $0 < x \leq 100$ . (Hint: express  $f$  as a piecewise-constant function.) Then, determine the cost of driving the van 93 miles.

$$\text{A) } f(x) = \begin{cases} 75x & \text{if } 0 < x \leq 40 \\ 75 + 7(x - 40) & \text{if } 40 < x \leq 100 \end{cases} ; \$7346$$

$$\text{B) } f(x) = \begin{cases} 75 & \text{if } 0 < x \leq 40 \\ 75 + 7(x + 40) & \text{if } 40 < x \leq 100 \end{cases} ; \$1006$$

$$\text{C) } f(x) = \begin{cases} 75 & \text{if } 0 < x \leq 40 \\ 75 + 7(x - 40) & \text{if } 40 < x \leq 100 \end{cases} ; \$1006$$

$$\text{D) } f(x) = \begin{cases} 75 & \text{if } 0 < x \leq 40 \\ 75 + 7(x - 40) & \text{if } 40 < x \leq 100 \end{cases} ; \$446$$

Answer: D

322) Sketch a graph showing the mileage that a person is from home after  $x$  hours if that individual drives at 35 mph to a lake 70 miles away, stays at the lake 1.5 hours, and then returns home at a speed of 70 mph.

A)

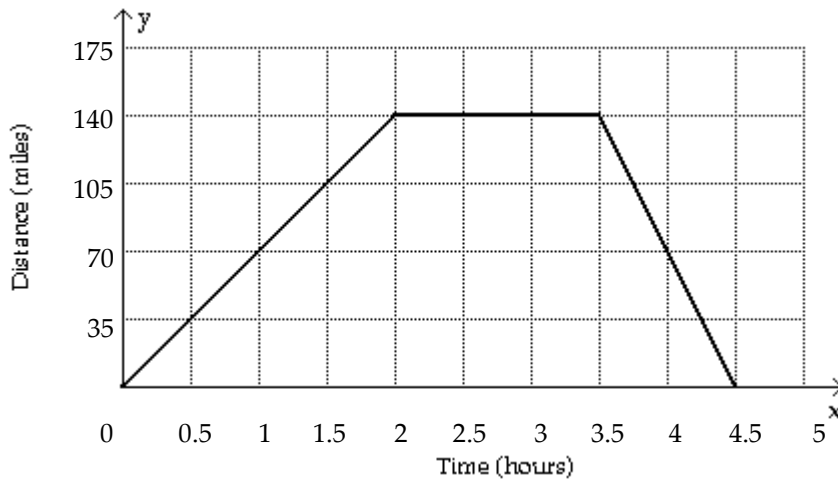

B)

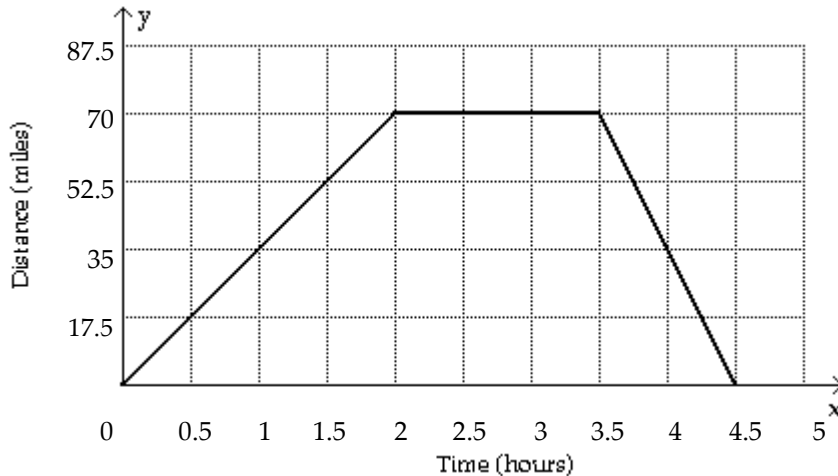

C)

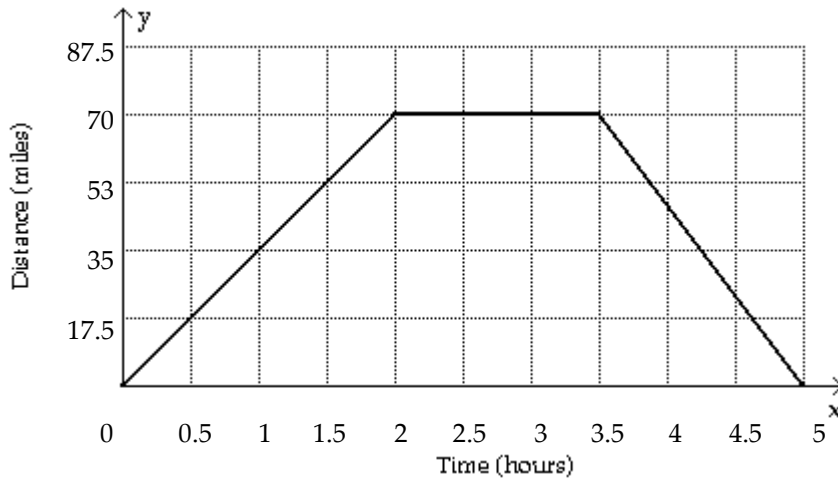

Answer: B

323) The table lists the average composite scores on a national entrance exam for selected years.

| Year  | 1982  | 1984  | 1986  | 1988  | 1990  | 1992  |
|-------|-------|-------|-------|-------|-------|-------|
| Score | 122.7 | 131.5 | 131.5 | 129.5 | 133.9 | 132.0 |

Make a line graph of the data. If the graph represents a piecewise-linear function  $f$ , find a symbolic representation for the piece of  $f$  located on the interval  $[1984, 1986]$ .

A)  $f(x) = 0.75x - 1358$  if  $1984 \leq x \leq 1988$

B)  $f(x) = 4.4x - 8606.9$  if  $1988 \leq x \leq 1990$

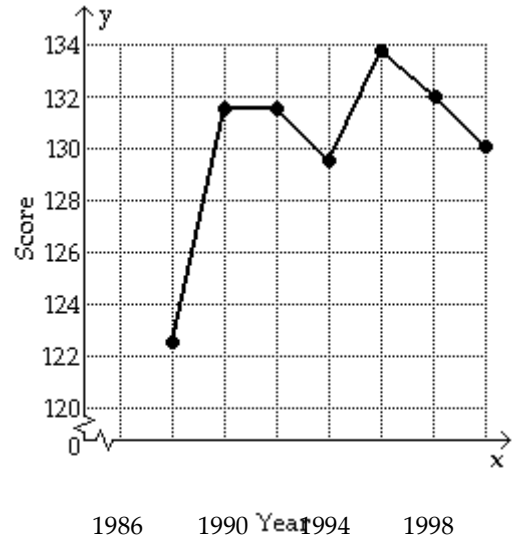
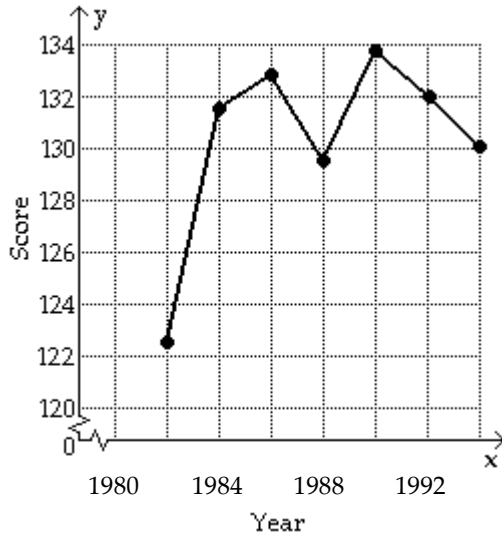

C)  $f(x) = 122.7$  if  $1988 \leq x \leq 1990$

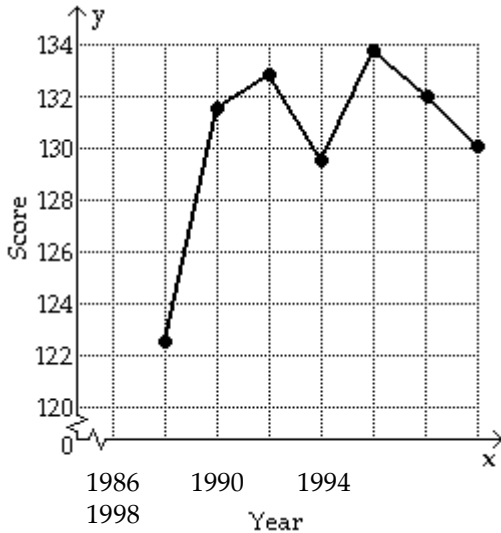

D)  $f(x) = 131.5$  if  $1984 \leq x \leq 1986$

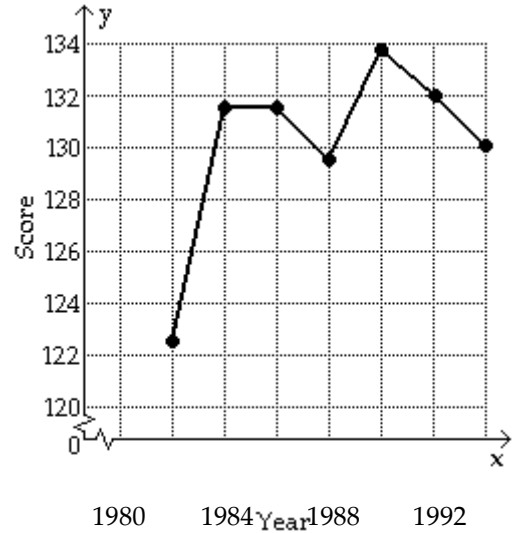

Answer: D

324) The table lists the average composite scores on a national entrance exam for selected years.

| Year  | 1980  | 1982  | 1984  | 1986  | 1988  | 1990  |
|-------|-------|-------|-------|-------|-------|-------|
| Score | 122.7 | 131.5 | 131.5 | 129.5 | 133.9 | 132.0 |

Evaluate  $f(1987)$ .

A) 131.5

B) 130.5

C) 131.7

D) 130.9

Answer: C

325) In Country X, the average hourly wage in dollars from 1945 to 1995 can be

$$\text{modeled by } f(x) = \begin{cases} 0.078(x - 1945) + 0.38 & \text{if } 1945 \leq x < 1970 \\ 0.181(x - 1970) + 3.03 & \text{if } 1970 \leq x \leq 1995 \end{cases}$$

Use  $f$  to estimate the average hourly wages in 1950, 1970, and 1990.

A) \$3.42, \$0.38, \$6.65

B) \$0.77, \$2.33, \$6.65

C) \$0.77, \$3.03, \$6.65

Answer: C

Describe the transformations that produce the graph of  $g$  from the graph of  $f$ .

326)  $f(x) = |x|$ ;  $g(x) = -5|x|$

A) Stretch vertically by a factor of 5. Reflect it across the  $y$ -axis.

B) Stretch horizontally by a factor of 5. Reflect it across the  $y$ -axis.

C) Stretch horizontally by a factor of 5. Reflect it across the  $x$ -axis.

D) Stretch vertically by a factor of 5. Reflect it across the  $x$ -axis.

Answer: D

327)  $f(x) = \sqrt{x}$ ;  $g(x) = -\sqrt{x+5}$

A) Shift 5 units to the left. Reflect it across the  $x$ -axis.

B) Shift 5 units to the left. Reflect it across the  $y$ -axis.



y-axis. C) Shift 5 units to the right. Reflect it across the x-axis.

D) Shift -5 units to the left. Reflect it across the x-axis.

Answer: A

328)  $f(x) = x^2$  ;  $g(x) = (x - 1)^2 - 5$

A) Shift 1 units to the left and 5 units upward.  
downward.

C) Shift 1 units to the left and 5 units downward.  
downward.

B) Shift 5 units to the right and 1 units

D) Shift 1 units to the right and 5 units

Answer: D

329)  $f(x) = x^3$  ;  $g(x) = -9x^3 + 3$

A) Stretch vertically by a factor of 9. Reflect it across the x-axis. Shift it 3 units upward.

B) Stretch vertically by a factor of 9. Reflect it across the y-axis. Shift it 3 units upward.

C) Stretch vertically by a factor of 3. Reflect it across the x-axis. Shift it 9 units upward.

D) Stretch vertically by a factor of 9. Reflect it across the x-axis. Shift it 3 units downward.

Answer: A

330)  $f(x) = \frac{1}{x}$  ;  $g(x) = \frac{3}{x} + 8$

A) Stretch vertically by a factor of  $\frac{1}{3}$ . Shift it 8 units up.

B) Shift it 3 units to the right and 8 units up.

C) Shift it 3 units to the left and 8 units  
down.

D) Stretch vertically by a factor of 3. Shift it 8 units up.

Answer: D

331)  $f(x) = \frac{1}{x}$  ;  $g(x) = \frac{1}{x + 12} - 5$

A) Shift it 12 units to the left and 5 units up.

B) Stretch vertically by a factor of 5 and shift it 12 units to the right.

C) Stretch horizontally by a factor of  $\frac{1}{2}$ . Shift it 5 units down.

D) Shift it 12 units to the left and 5 units

down. Answer: D

332)  $f(x) = x^2$  ;  $g(x) = -(x - 11)^2 + 10$

A) Shift it 11 units to the right. Reflect it across the x-axis. Shift it 10 units up.

B) Shift it 11 units to the right. Reflect it across the y-axis. Shift it 10 units

up. C) Shift it 11 units to the left. Reflect it across the x-axis. Shift it 10  
units up.

D) Shift it 11 units to the right. Reflect it across the y-axis. Shift it 10 units down.

Answer: A

Match the graph with its corresponding function.

333)

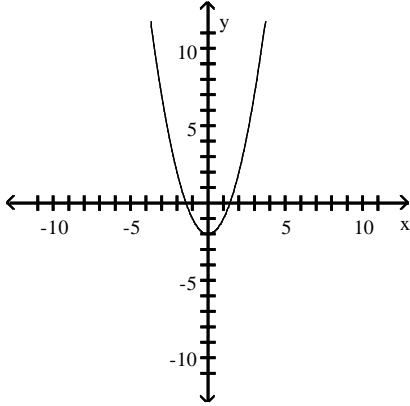

A)  $g(x) = x^2 - 2$

B)  $g(x) = (x - 2)^2$

C)  $g(x) = 2x^2$

D)  $g(x) = x^2 + 2$

Answer: A

334)

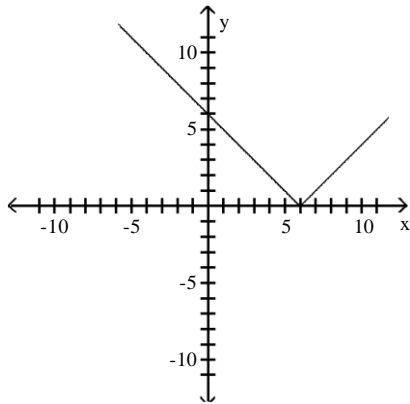

A)  $g(x) = 6x^3$

B)  $g(x) = |x| - 6$

C)  $g(x) = |x + 6|$

D)  $g(x) = |x - 6|$

Answer: D

335)

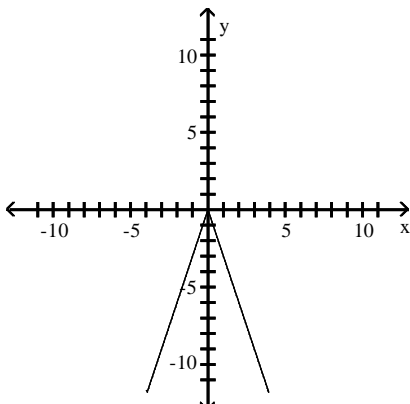

A)  $g(x) = |x - 3|$

B)  $g(x) = |x + 3|$

C)  $g(x) = |3x|$

D)  $g(x) = |x|$

Answer: C

336)

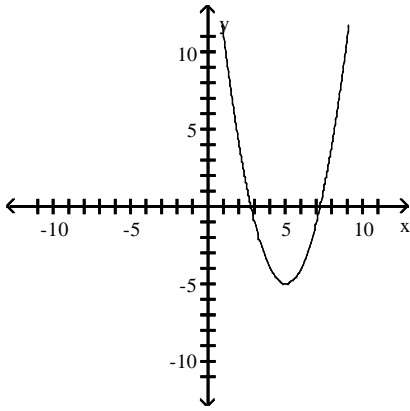

A)  $g(x) = (x - 5)^2 - 5$

B)  $g(x) = -2(x - 5)^2$

C)  $g(x) = (x - 2)^2 - 5$

D)  $g(x) = 2(x + 5)^2$

Answer: A

337)

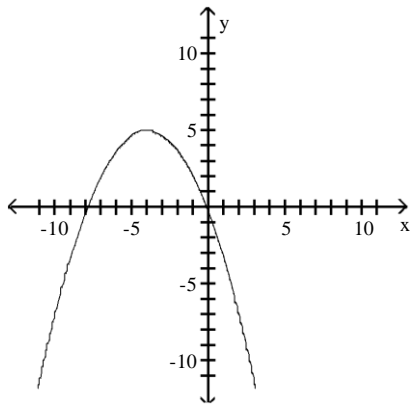

A)  $g(x) = (x + 4)^2 + 5$

B)  $g(x) = \frac{1}{3}(x - 4)^2 - 5$

C)  $g(x) = -\frac{1}{3}(x + 4)^2$

D)  $g(x) = \frac{1}{3}(x + 4)^2 + 5$

Answer: D

338)

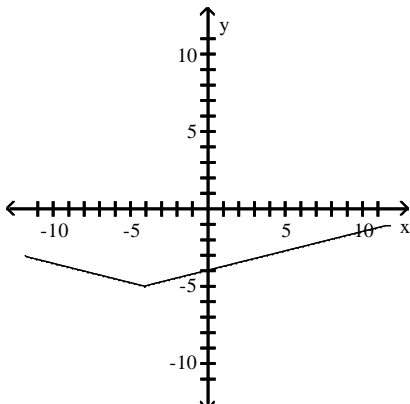

A)  $g(x) = 5|x + 4| - 0.25$

B)  $g(x) = 5|x - 4| + 0.25$

C)  $g(x) = 0.25|x + 4| - 5$

D)  $g(x) = 0.25|x - 4| + 5$

Answer: C

Graph the function by starting with a function from the library of functions and then using the techniques of shifting, compressing, stretching, and/or reflecting.

339)  $g(x) = x^2 - 6$

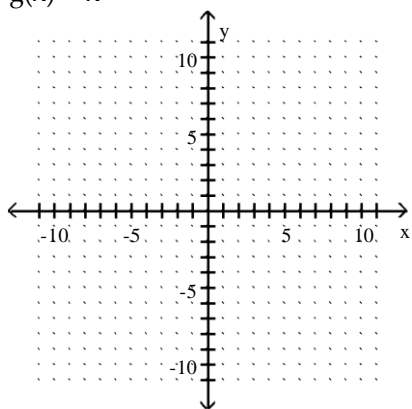

A)

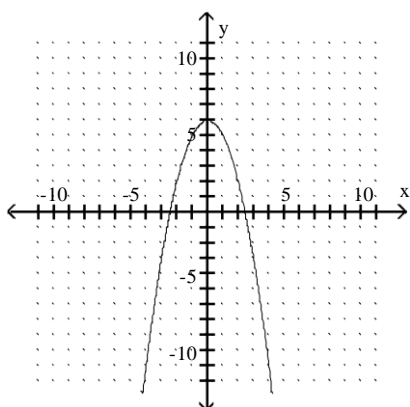

B)

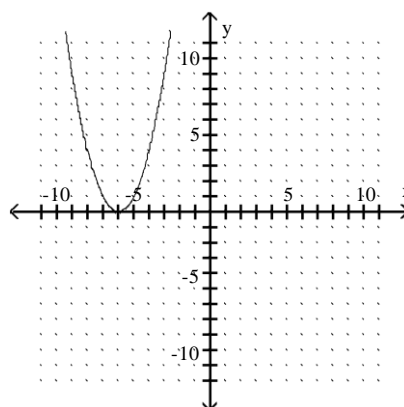

C)

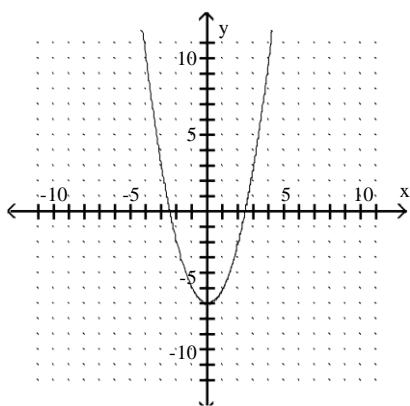

D)

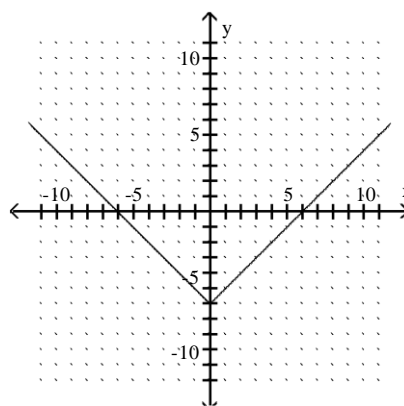

Answer: C

340)  $g(x) = (x - 2)^2 - 4$

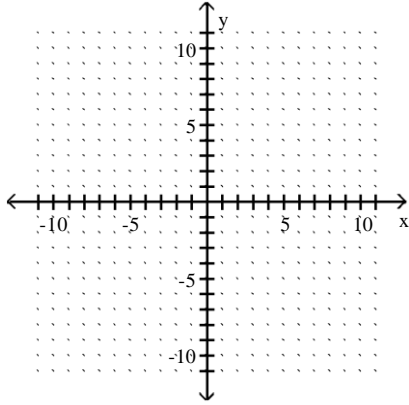

A)

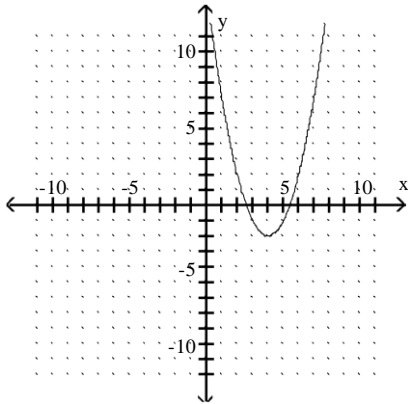

B)

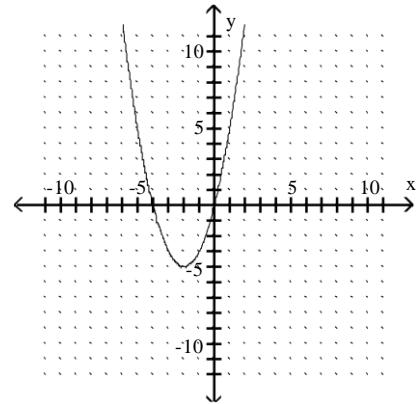

C)

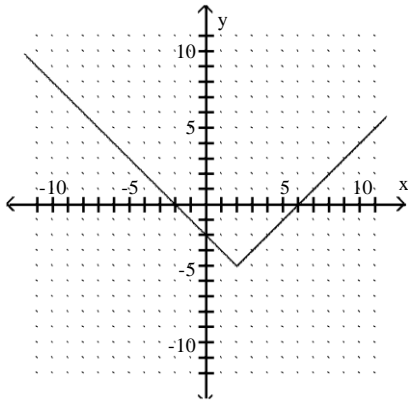

D)

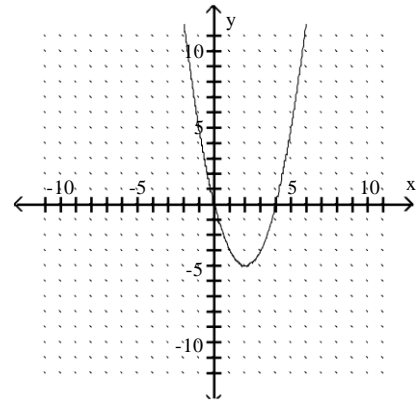

Answer: D

341)  $g(x) = -\frac{1}{2}(x+3)^2 +$

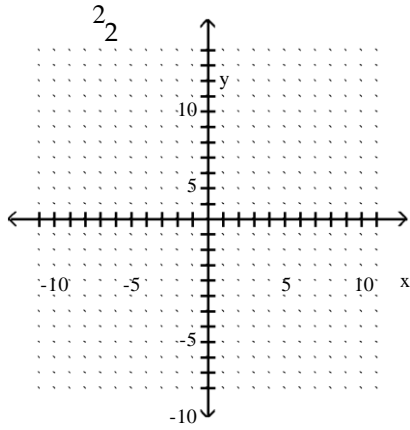

A)

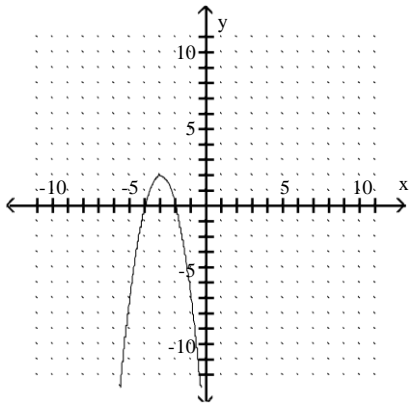

B)

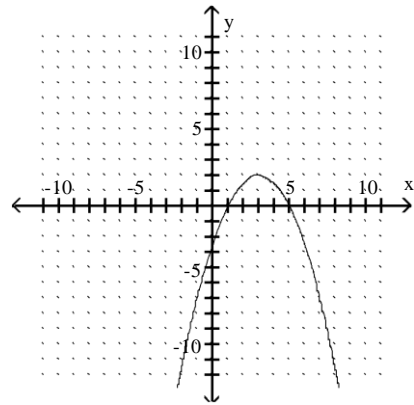

C)

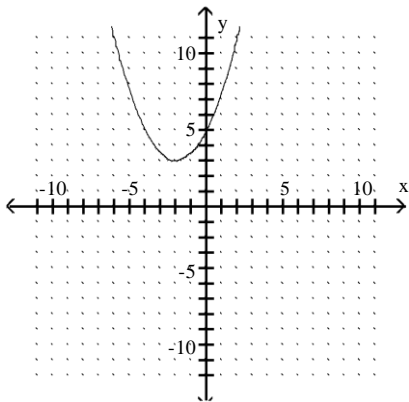

D)

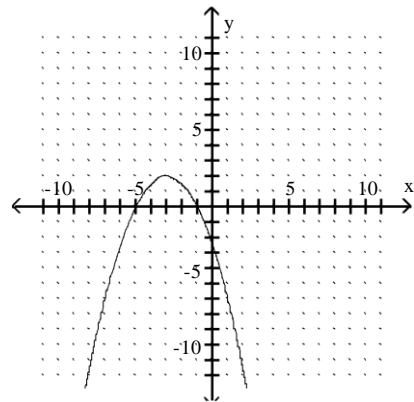

Answer: D

342)  $g(x) = -2|x|$

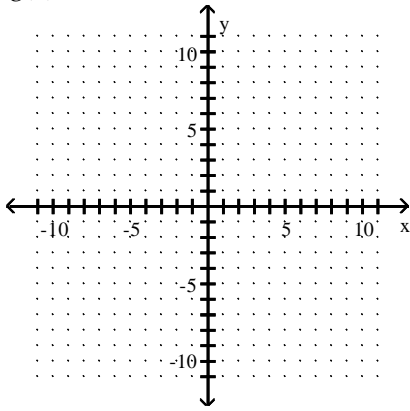

A)

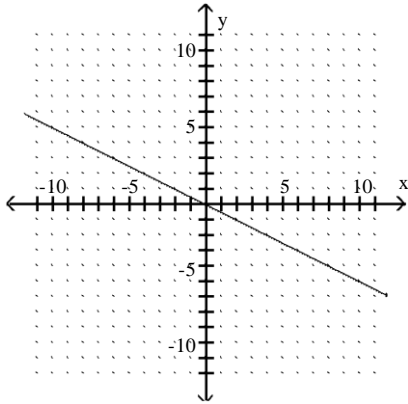

C)

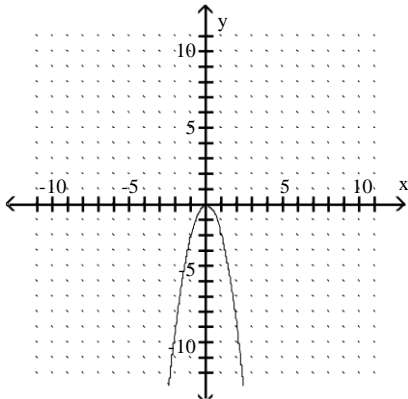

B)

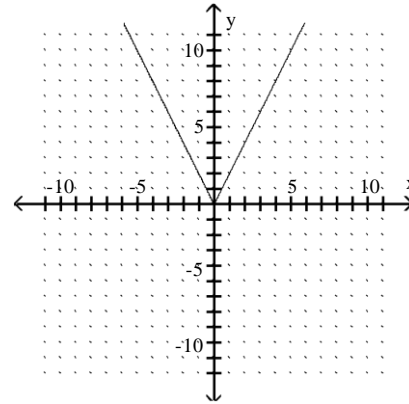

D)

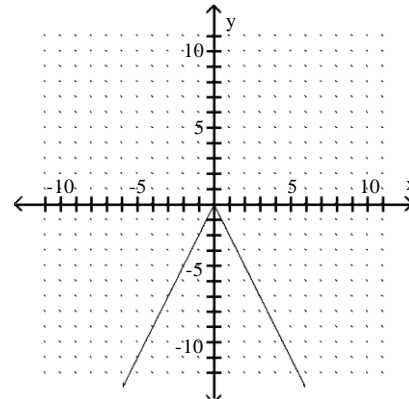

Answer: D



343)  $g(x) = \frac{1}{4}|x + 5| - 4$

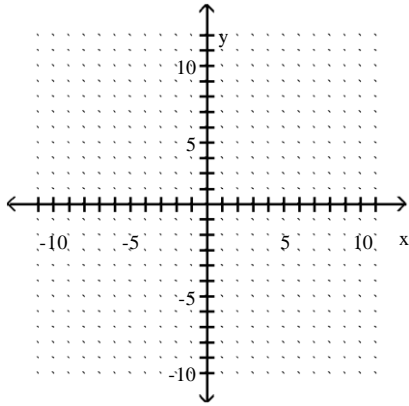

A)

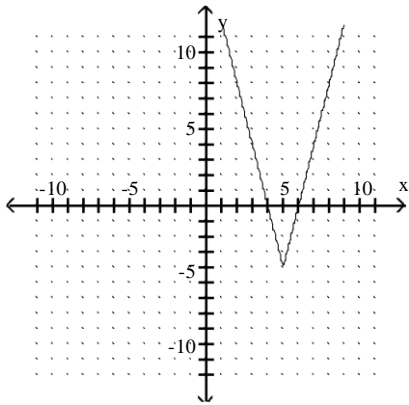

B)

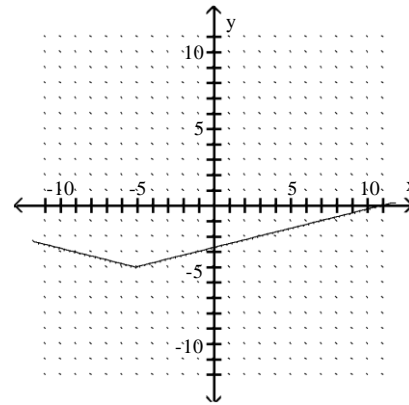

C)

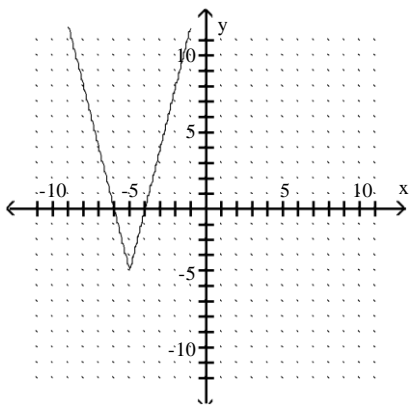

D)

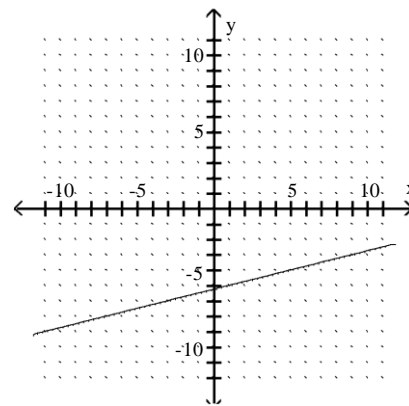

Answer: B

344)  $g(x) = |x - 2|$

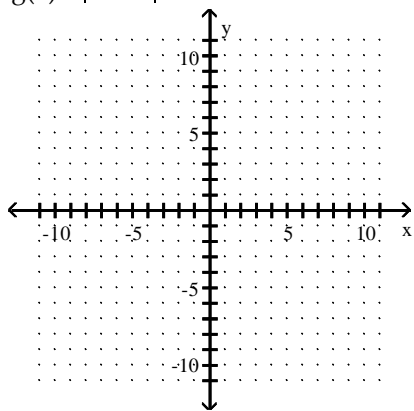

A)

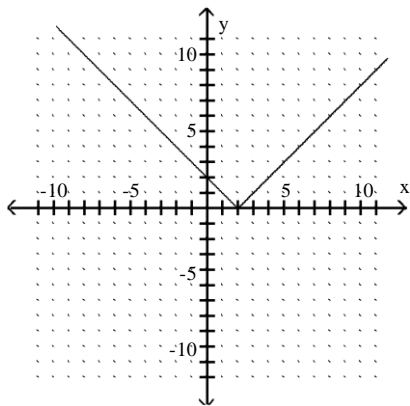

B)

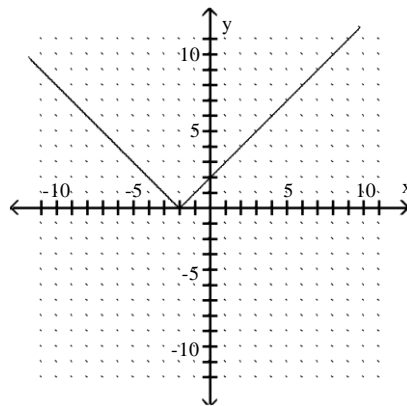

C)

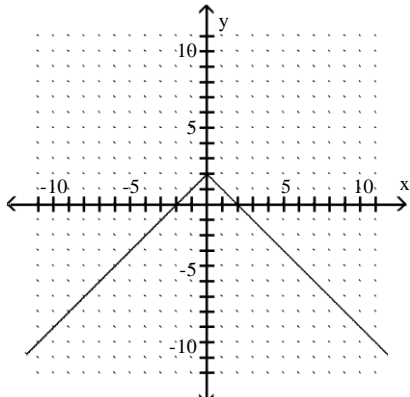

D)

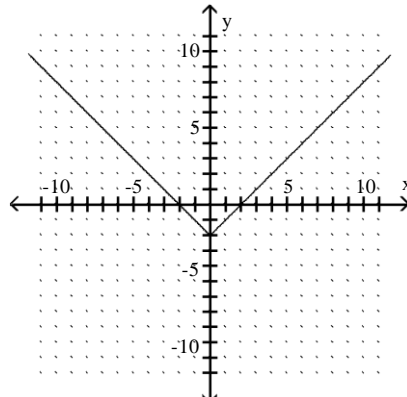

Answer: A

345)  $g(x) = (x + 5)^3$

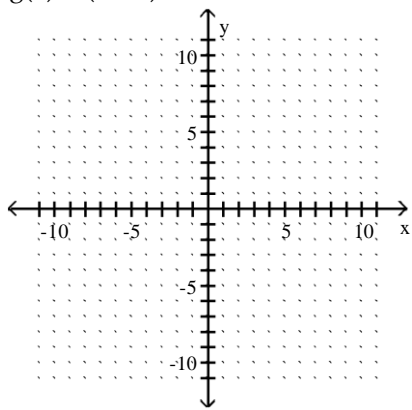

A)

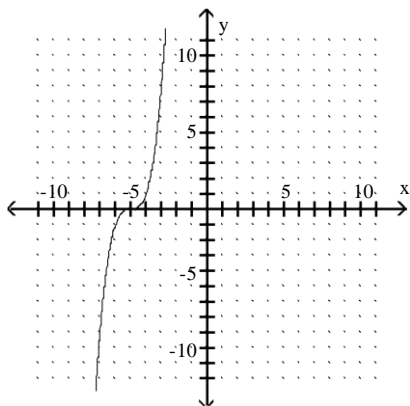

B)

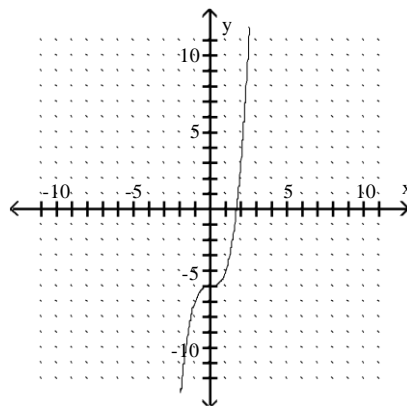

C)

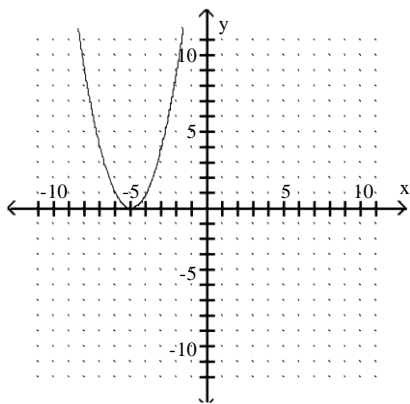

D)

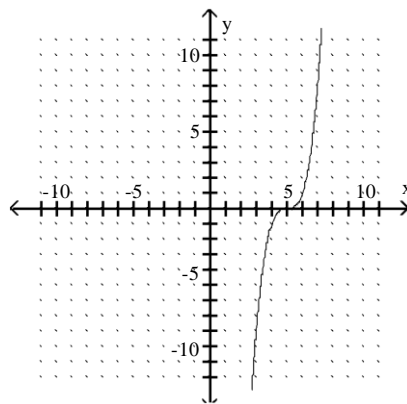

Answer: A

346)  $g(x) = -\sqrt{x+2} - 2$

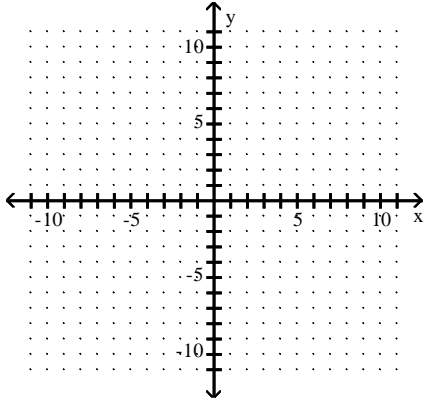

A)

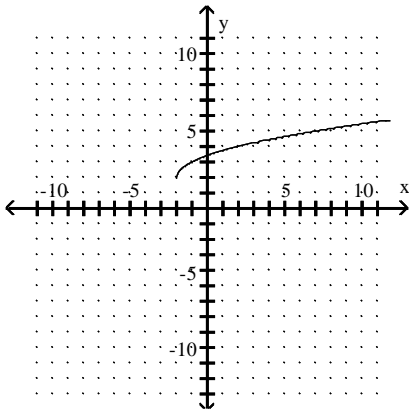

C)

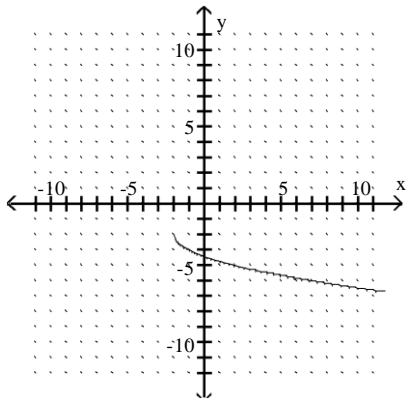

B)

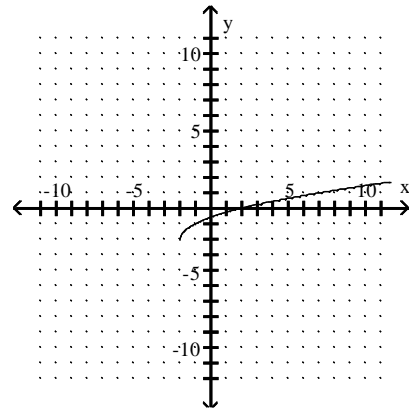

D)

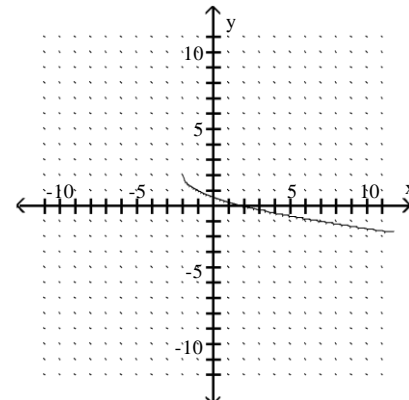

Answer: C

Write an equation for a function whose graph fits the given description.

347) The graph of  $f(x) = x^2$  is vertically stretched by a factor of 4, and the resulting graph is reflected across the x-axis.

A)  $f(x) = -4x^2$

B)  $f(x) = 4(x - 4)x^2$

C)  $f(x) = 4x^2$

D)  $f(x) = (x - 4)^2$

Answer: A

348) The graph of  $f(x) = x^2$  is shifted 4 units to the left and 6 units downward.

A)  $y = (x + 4)^2 - 6$

B)  $y = (x - 6)^2 + 4$

C)  $y = (x + 6)^2 - 4$

D)  $y = (x - 4)^2 - 6$

Answer: A

- 349) The graph of  $f(x) = x^2$  is shifted 4 units to the left. This graph is then vertically stretched by a factor of 5 and reflected across the x-axis. Finally, the graph is shifted 7 units downward.
- A)  $y = -5(x - 4)^2 + 7$       B)  $y = -5(x + 7)^2 - 4$       C)  $y = -5(x - 4)^2 - 7$       D)  $y = -5(x + 4)^2 - 7$

Answer: D

- 350) The graph of  $f(x) = x^2$  is shifted 3 units to the left. This graph is then vertically shrunk by a factor of  $\frac{1}{6}$  and reflected across the x-axis. Finally, the graph is shifted 7 units downward.
- A)  $y = \frac{1}{6}(x - 3)^2 - 7$       B)  $y = -\frac{1}{6}(x - 3)^2 - 7$       C)  $y = -\frac{1}{6}(x + 3)^2 - 7$       D)  $y = -\frac{1}{6}(x - 3)^2 + 7$

Answer: C

- 351) The graph of  $f(x) = |x|$  is vertically stretched by a factor of 10, and the resulting graph is reflected across the x-axis.
- A)  $y = -10|x|$       B)  $y = |x + 10|$       C)  $y = 10|x|$       D)  $y = -|x|$

Answer: D

- 352) The graph of  $f(x) = |x|$  is reflected across the y-axis. This graph is then vertically stretched by a factor of 3.7. Finally, the graph is shifted 4 units downward.
- A)  $f(x) = 3.7|x| + 4$       B)  $f(x) = 3.7|x| - 4$       C)  $f(x) = -3.7|x| - 4$       D)  $f(x) = -3.7|x| + 4$

Answer: B

- 353) The graph of  $f(x) = |x|$  is reflected across the y-axis and vertically shrunk by a factor of  $\frac{1}{3}$ . This graph is then reflected across the x-axis. Finally, the graph is shifted 4 units upward.

A)  $y = \left| -x - \frac{1}{3} \right| + 4$       B)  $y = -\left| \frac{1}{3}x \right| + 4$       C)  $y = \left| \frac{1}{3}x \right| + 4$       D)  $y = \left| \frac{1}{3}x \right| + 4$

Answer: B

- 354) The graph of  $f(x) = \sqrt{x}$  is shifted 8 units to the right.
- A)  $y = \sqrt{x - 8}$       B)  $y = \sqrt{x + 8}$       C)  $y = \sqrt{x + 8}$       D)  $y = \sqrt{x} + 8$

Answer: B

- 355) The graph of  $f(x) = \sqrt{x}$  is shifted 2 units to the left and then shifted 5 units
- A)  $f(x) = 5\sqrt{x + 2}$       B)  $f(x) = \sqrt{x + 5} + 2$       C)  $f(x) = \sqrt{x + 2} + 5$       D)  $f(x) = \sqrt{x - 2} + 5$

Answer: C

- 356) The graph of  $f(x) = x^4$  shifted right 4 units and up 4 units.
- A)  $y = -(x - 4)^4 + 4$       B)  $y = (x + 4)^4 - 4$       C)  $y = (x - 4)^4 + 4$       D)  $y = -(x - 4)^4 + 4$

Answer: C

357)  $g(x) = 2f(x)$

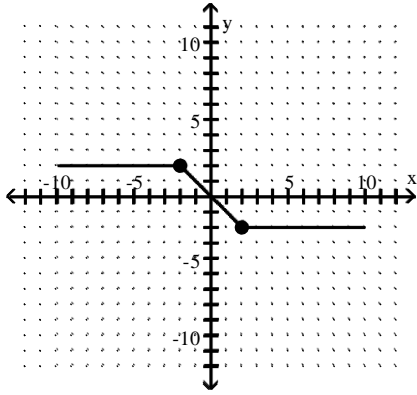

A)

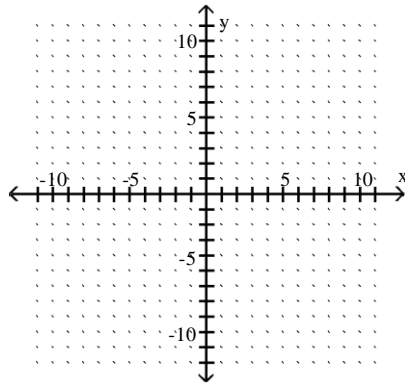

B)

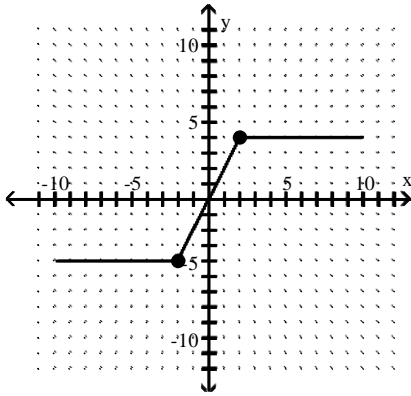

C)

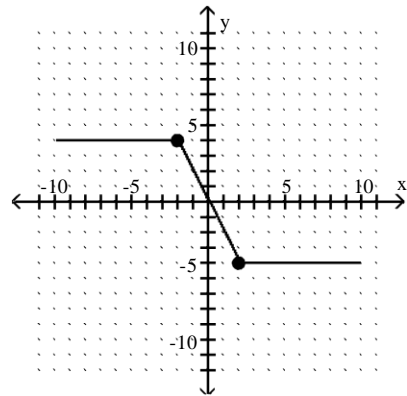

D)

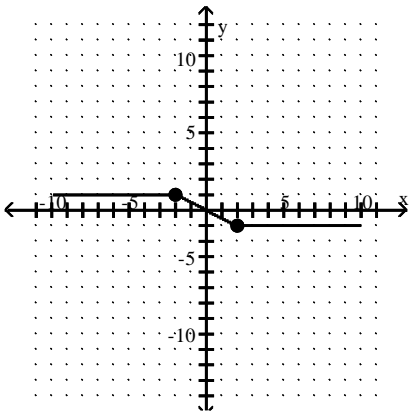

Answer: B

358)  $g(x) = -\frac{1}{2}f(x)$

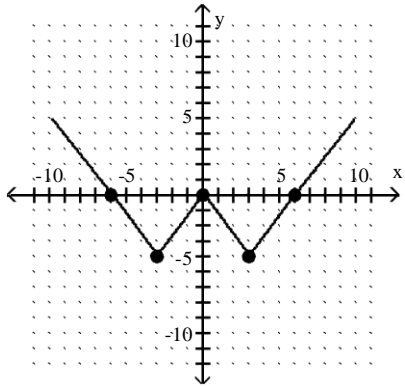

A)

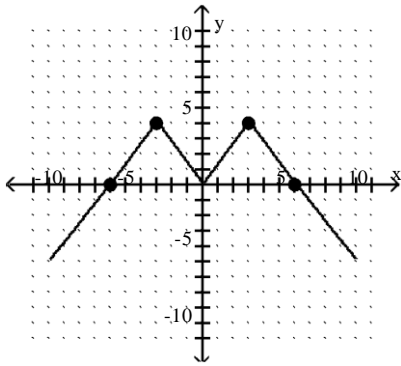

C)

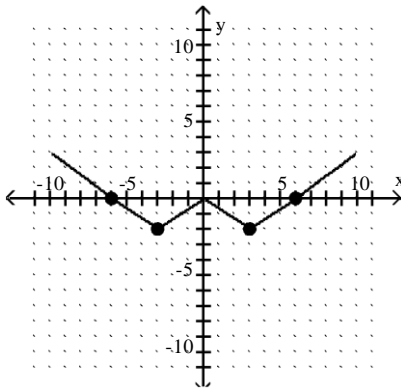

B)

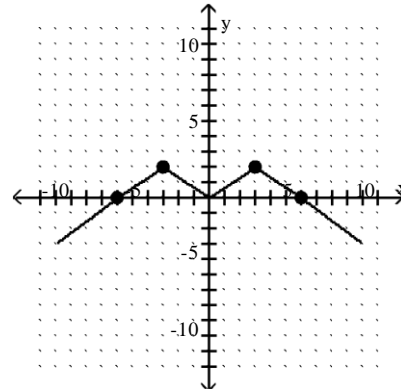

D)

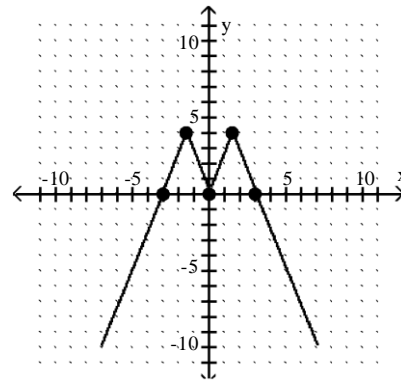

Answer: B

359)  $g(x) = f(2x)$

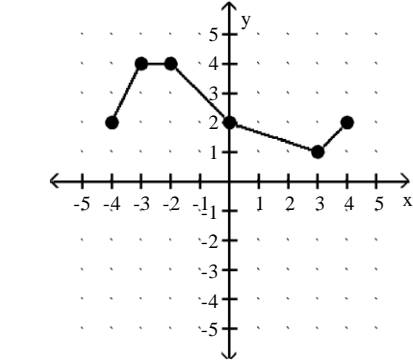
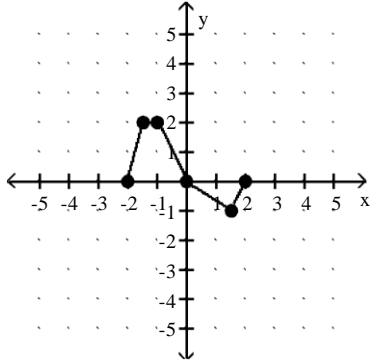
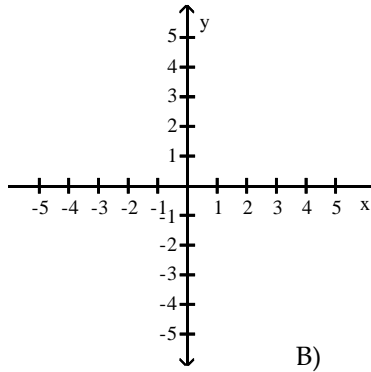
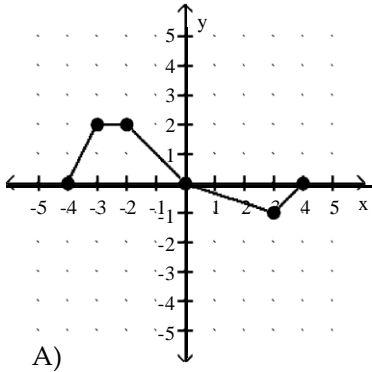

C)

D)

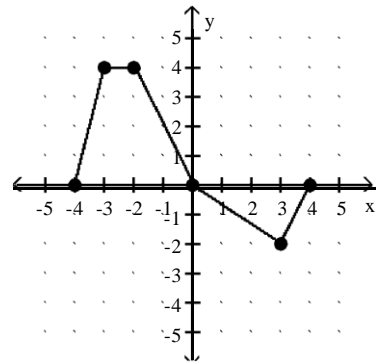
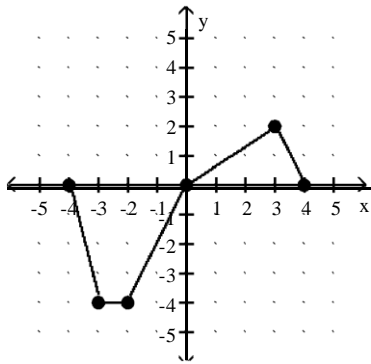

Answer: A

360)  $g(x) = f\left(-\frac{1}{2}x\right)$

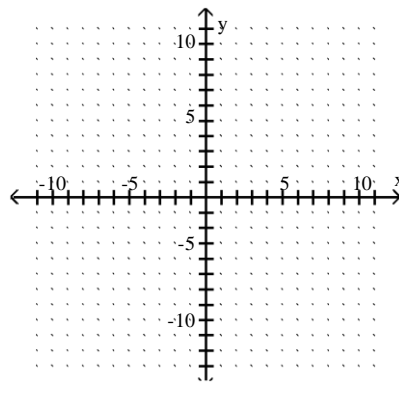
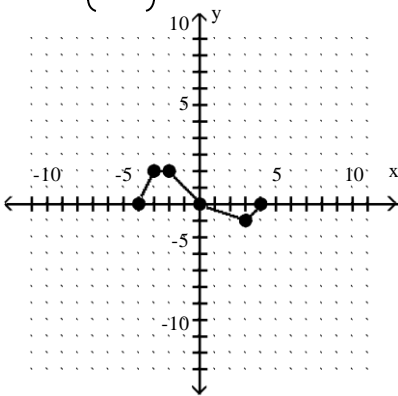



A)

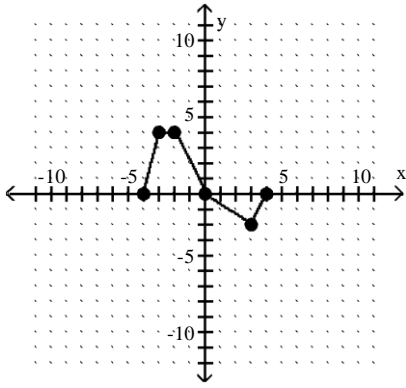

B)

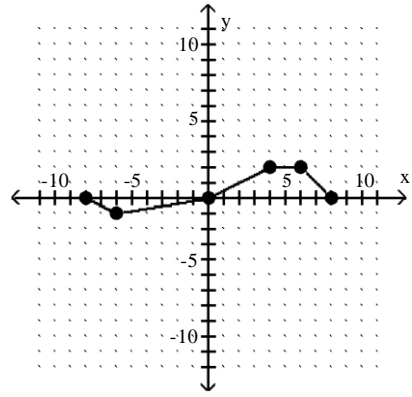

C)

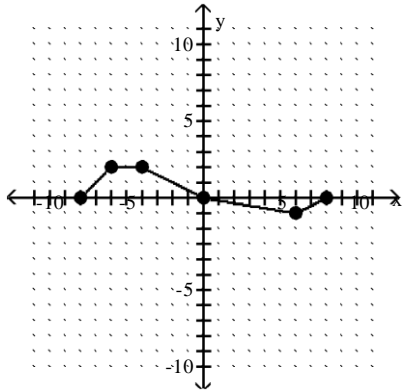

D)

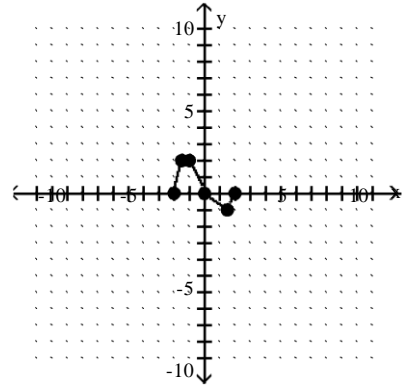

Answer: B

361)  $g(x) = -2f(x + 1) - 3$

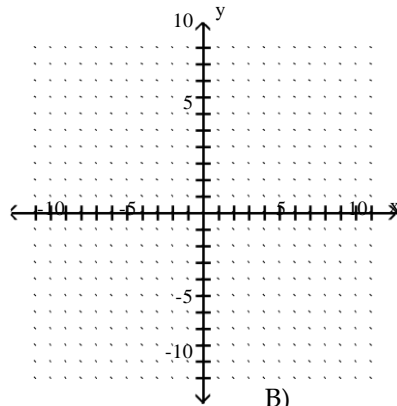
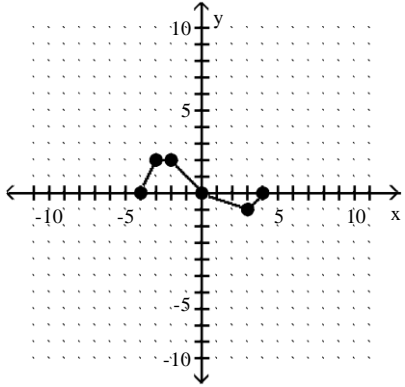

A)

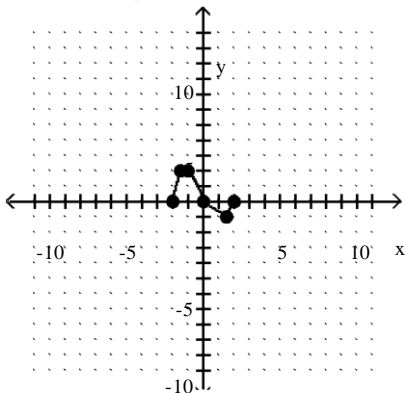

B)

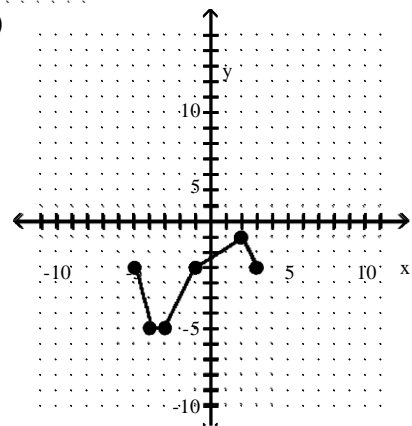

C)

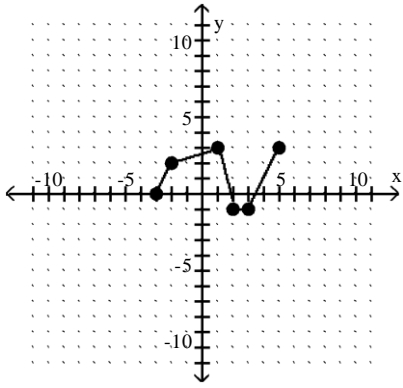

D)

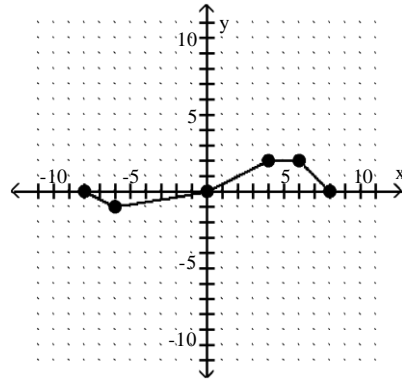

Answer: B

362)  $g(x) = \frac{1}{2}f(x - 1) +$

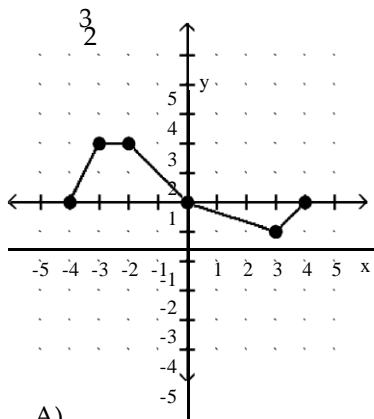

A)

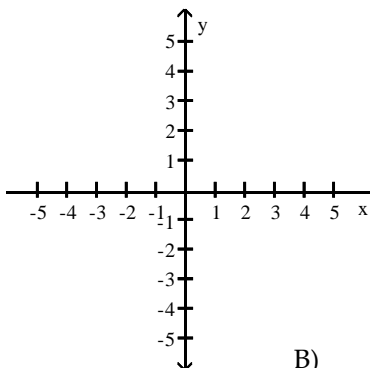

B)

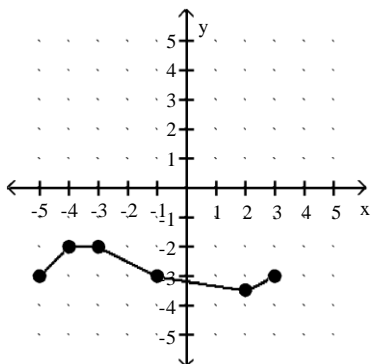

C)

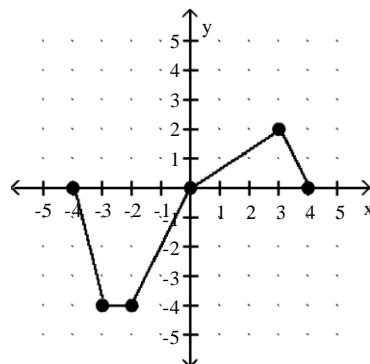

D)

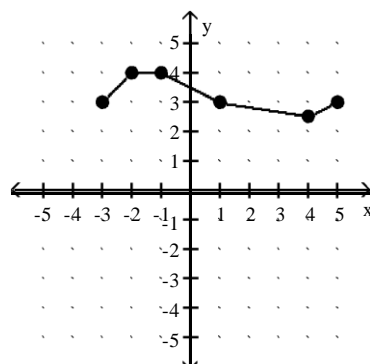
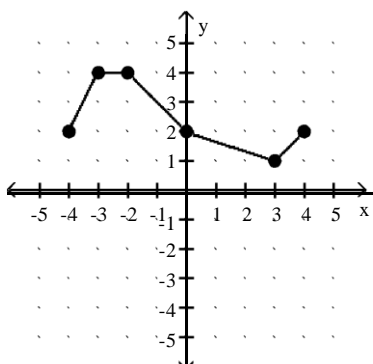

Answer: D

Write the new function.

363) The linear function  $f(x) = 246x + 6320$  provides an approximation of the annual cost (in dollars) to rent an apartment at the Leisure Village Retirement Community, where  $x = 1$  represents 1976,  $x = 2$  represents 1977, and so on. Write a new function,  $g(x)$ , that yields the same  $f(x)$ -values when the exact year number is entered.

A)  $g(x) = 246(x - 1976) + 6320$

B)  $g(x) = 246(1975 - x) + 6320$

C)  $g(x) = 246(1976 - x) + 6320$

D)  $g(x) = 246(x - 1975) + 6320$

Answer: D

364) The linear function  $f(x) = 74.97x + 1071$  provides an approximation of the value (in dollars) of an account opened on January 1, 1990, in the amount of \$1071 and earning 7% simple interest, where  $x = 0$  represents January 1, 1990,  $x = 1$  represents January 1, 1991,  $x = 2$  represents January 1, 1992, and so on. Write a new function,  $g(x)$ , that yields the same  $f(x)$ -values when the exact year number is entered.

- A)  $g(x) = 74.97(1990 - x) + 1071$                       B)  $g(x) = 74.97(1991 - x) + 1071$   
 C)  $g(x) = 74.97(x - 1990) + 1071$                       D)  $g(x) = 74.97(x - 1991) + 1071$

Answer: C

365) The linear function  $f(x) = 449x + 3420$  provides an approximation of the annual cost (in dollars) of health insurance for a family of three, where  $x = 1$  represents 1981,  $x = 2$  represents 1982, and so on. Write a new function,  $g(x)$ , that yields the same  $f(x)$ -values when the exact year number is entered.

- A)  $g(x) = 449(x - 1980) + 3420$                       B)  $g(x) = 449(1981 - x) + 3420$   
 C)  $g(x) = 449(1980 - x) + 3420$                       D)  $g(x) = 449(x - 1981) + 3420$

Answer: A

Find the given value.

366) Find  $(f + g)(-3)$  when  $f(x) = x + 3$  and  $g(x) = x + 5$ .

- A) -8                      B) -14                      C) 2                      D) -4

Answer: C

367) Find  $(f + g)(6)$  when  $f(x) = \frac{6}{\sqrt{4x + 3}}$  and  $g(x) = 5x -$

- A) -2                      B) 28                      C) 40                      D) 32

Answer: B

368) Find  $(f - g)(1)$  when  $f(x) = 2x^2 + 6$  and  $g(x) = x + 7$ .

- A) -9                      B) 0                      C) 2                      D) 14

Answer: B

369) Find  $(f - g)(-5)$  when  $f(x) = x + 5$  and  $g(x) = \sqrt{x - 2}$

- A)  $\sqrt{2}$                       B) 0                      C)  $\sqrt{7}$                       D) Does not exist

Answer: D

370) Find  $(f \cdot g)(-3)$  when  $f(x) = x + 5$  and  $g(x) = 5x^2 + 19x - 1$ .

- A) -26                      B) -98                      C) -352                      D) 104

Answer: A

371) Find  $(f \cdot g)(3)$  when  $f(x) = \frac{x}{4x^2 + 9x + 20}$  and  $g(x) = x +$

- A)  $\frac{3}{8}$                       B)  $\frac{15}{56}$                       C)  $\frac{15}{26}$                       D)  $\frac{21}{26}$

Answer: A

372) Find  $\left(\frac{f}{g}\right)(-2)$  when  $f(x) = 4x - 6$  and  $g(x) = 5x^2 + 14x + 2$ .

- A)  $-\frac{1}{3}$                       B)  $-\frac{1}{6}$                       C)  $-\frac{1}{3}$                       D)  $-\frac{1}{2}$

Answer: C

373) Find  $\left(\frac{f}{g}\right)(5)$  when  $f(x) = x^2 - 2$  and  $g(x) = 5x + 1$

A)  $-\frac{2}{3}$

B) 0

C)  $\frac{1}{2}$

D) Does not exist

Answer: D

For the given functions  $f$  and  $g$ , find the requested function and state its domain.

374)  $f(x) = 2 - 9x$ ;  $g(x) = -4x + 9$

Find  $f + g$ .

A)  $(f + g)(x) = -5x + 11$ ;  $\left(-\infty, \frac{11}{5}\right) \cup \left(\frac{11}{5}, \infty\right)$

B)  $(f + g)(x) = -13x + 11$ ;  $(-\infty, \infty)$

C)  $(f + g)(x) = -4x + 2$ ;  $\left(-\infty, \frac{1}{2}\right) \cup \left(\frac{1}{2}, \infty\right)$

D)  $(f + g)(x) = -2x$ ;  $(-\infty, \infty)$

Answer: B

375)  $f(x) = 8x - 3$ ;  $g(x) = 4x - 9$

Find  $f - g$ .

A)  $(f - g)(x) = 4x + 6$ ;  $(-\infty, \infty)$

B)  $(f - g)(x) = 12x - 12$ ;  $(-\infty, \infty)$

C)  $(f - g)(x) = -4x - 6$ ;  $(-\infty, \infty)$

D)  $(f - g)(x) = 4x - 12$ ;  $(-\infty, \infty)$

Answer: A

376)  $f(x) = 4x - 6$ ;  $g(x) = 6x - 3$

Find  $f \cdot g$ .

A)  $(f \cdot g)(x) = 10x^2 - 48x - 9$ ;  $(-\infty, \infty)$

B)  $(f \cdot g)(x) = 24x^2 - 39x + 18$ ;  $(-\infty, 18) \cup (18, \infty)$

C)  $(f \cdot g)(x) = 24x^2 - 48x + 18$ ;  $(-\infty, \infty)$

D)  $(f \cdot g)(x) = 24x^2 + 18$ ;  $(-\infty, 18) \cup (18, \infty)$

Answer: C

377)  $f(x) = 3x + 1$ ;  $g(x) = 2x - 3$

Find  $\frac{f}{g}$ .

A)  $\left(\frac{f}{g}\right)(x) = \frac{3x+1}{2x-3}$ ;  $\left(-\infty, -\frac{1}{2}\right) \cup \left(-\frac{1}{2}, \infty\right)$

B)  $\left(\frac{f}{g}\right)(x) = \frac{3x+1}{2x-3}$ ;  $\left(-\infty, \frac{3}{2}\right) \cup \left(\frac{3}{2}, \infty\right)$

C)  $\left(\frac{f}{g}\right)(x) = \frac{3x+1}{2x-3}$ ;  $\left(-\infty, -\frac{1}{2}\right) \cup \left(-\frac{1}{2}, \infty\right)$

D)  $\left(\frac{f}{g}\right)(x) = \frac{2x-3}{3x+1}$ ;  $\left(-\infty, \frac{3}{2}\right) \cup \left(\frac{3}{2}, \infty\right)$

Answer: B

378)  $f(x) = 16 - x^2$ ;  $g(x) = 4 - x$

Find  $f + g$ .

A)  $(f + g)(x) = -x^2 - x + 20$ ;  $(-\infty, \infty)$

B)  $(f + g)(x) = x^3 - 4x^2 - 16x + 64$ ;  $(-\infty, \infty)$

C)  $(f + g)(x) = 4 + x$ ;  $(-\infty, -4) \cup (-4, \infty)$

D)  $(f + g)(x) = -x^2 + x + 12$ ;  $(-\infty, \infty)$

Answer: A

379)  $f(x) = x - 6$ ;  $g(x) = 2x^2$

Find  $f - g$ .

A)  $(f - g)(x) = -2x^2 + x - 6$ ;  $(-\infty, 6) \cup (6, \infty)$

$\infty$ ) C)  $(f - g)(x) = -2x^2 + x - 6$ ;  $(-\infty, \infty)$

B)  $(f - g)(x) = 2x^2 + x - 6$ ;  $(-\infty,$

D)  $(f - g)(x) = 2x^2 - x + 6$ ;  $(-$

Answer: C

380)  $f(x) = 3x^3 + 2$ ;  $g(x) = 3x^2 + 2$

Find  $f \cdot g$ .

A)  $(f \cdot g)(x) = 9x^5 + 6x^3 + 6x^2 + 4$ ;  $(-\infty, \infty)$

C)  $(f \cdot g)(x) = 9x^5 + 6x^3 + 6x^2 + 4$ ;  $(-\infty, 0) \cup (0, \infty)$

$\infty, \infty$ ) Answer: A

B)  $(f \cdot g)(x) = 3x^3 + 3x^2 + 4$ ;  $(-\infty, \infty)$

D)  $(f \cdot g)(x) = 9x^6 + 6x^3 + 6x^2 + 4$ ;  $(-\infty, \infty)$

381)  $f(x) = \sqrt{x}$ ;  $g(x) = 2x - 9$

Find  $\frac{f}{g}$ .

A)  $\left(\frac{f}{g}\right)(x) = \frac{\sqrt{x}}{2x-9}$ ;  $\left[\infty, \frac{9}{2}\right) \cup \left(\frac{9}{2}, \infty\right)$

C)  $\left(\frac{f}{g}\right)(x) = \frac{2x-9}{\sqrt{x}}$ ;  $[0, \infty)$

Answer: D

B)  $\left(\frac{f}{g}\right)(x) = \frac{\sqrt{x}}{2x-9}$ ;  $(-\infty, 0) \cup (0, \infty)$

D)  $\left(\frac{f}{g}\right)(x) = \frac{\sqrt{x}}{2x-9}$ ;  $\left[\frac{9}{2}, \frac{9}{2}\right) \cup \left(\frac{9}{2}, \infty\right)$

382)  $f(x) = \frac{9x+5}{5x-6}$ ;  $g(x) = \frac{6x}{5x-6}$

Find  $f + g$ .

A)  $(f + g)(x) = \frac{3x-5}{5x-6}$ ;  $\left(-\infty, \frac{6}{5}\right) \cup \left(\frac{6}{5}, \infty\right)$

C)  $(f + g)(x) = \frac{15x+5}{5x-6}$ ;  $(-\infty, 0) \cup (0, \infty)$

Answer: B

B)  $(f + g)(x) = \frac{15x+5}{5x-6}$ ;  $\left(-\infty, \frac{6}{5}\right) \cup \left(\frac{6}{5}, \infty\right) \{x | x \neq \frac{6}{5}\}$

D)  $(f + g)(x) = \frac{15x+5}{5x-6}$ ;  $(-\infty, -\frac{1}{3}) \cup \left(-\frac{1}{3}, \infty\right)$

383)  $f(x) = \sqrt{x+9}$ ;  $g(x) = \frac{2}{x}$

Find  $f \cdot g$ .

A)  $(f \cdot g)(x) = \frac{\sqrt{2x+18}}{x}$ ;  $[-9, 0) \cup (0, \infty)$

C)  $(f \cdot g)(x) = \frac{2\sqrt{x+9}}{x}$ ;  $[-9, 0) \cup (0, \infty)$

Answer: C

B)  $(f \cdot g)(x) = \sqrt{\frac{2x+18}{x}}$ ;  $[0, 9) \cup (9, \infty)$

D)  $(f \cdot g)(x) = \sqrt{\frac{11}{x}}$ ;  $(-\infty, 0) \cup (0, \infty)$

Evaluate the expression.

384)  $(g \circ f)(-3)$  when  $f(x) = \frac{x-3}{6}$  and  $g(x) = 2x + 9$ .

A) 7

B) -3

C) -11

D) 0

Answer: A

385)  $(f \circ g)(-2)$  when  $f(x) = -2x - 5$  and  $g(x) = -4x^2 - 7x - 9$ .

A) -31

B) 2

C) 17

D) -6



Answer: C

386)  $(g \circ f)(-5)$  when  $f(x) = 6x - 4$  and  $g(x) = 5x^2 + 9x - 6$ .

A) 5468

B) -482

C) -460

D) 440

Answer: A

- 387)  $(f \circ g)(a)$  when  $f(x) = 4x +$  and  $g(x) = 4x - 1$ .  
 A)  $16a + 14$  B)  $16a + 19$  C)  $16a + 11$  D)  $16a + 59$

Answer: C

- 388)  $(g \circ f)(c)$  when  $f(x) = -3x +$  and  $g(x) = 5x + 4$ .  
 A)  $-15c + 21$  B)  $-15c + 49$  C)  $-15c - 41$  D)  $15c + 49$

Answer: B

- 389)  $(f \circ f)(5)$  when  $f(x) = 3x + 2$  and  $g(x) = 2x^2 + 3$   
 A) 23 B) 53 C) 17 D) 37

Answer: B

- 390)  $(g \circ g)(10)$  when  $f(x) = 2x + 2$  and  $g(x) = 4x^2 + 2$   
 A) 633,614 B) 1610 C) 161,606 D) 646,418

Answer: D

Find the composite function for the given functions.

- 391)  $f \circ g$  for  $f(x) = 8x + 7$  and  $g(x) = 4x - 1$   
 A)  $32x + 15$  B)  $32x + 27$  C)  $32x + 6$  D)  $32x - 1$

Answer: D

- 392)  $f \circ g$  for  $f(x) = 3x + 4$  and  $g(x) = -5x + 5$   
 A)  $15x + 19$  B)  $-15x$  C)  $-15x + 25$  D)  $-15x + 19$

Answer: D

- 393)  $f \circ g$  for  $f(x) = 4x + 4$  and  $g(x) = x^2 - 9$   
 A)  $x^2 + 4x - 5$  B)  $16x^2 + 8x - 4$  C)  $x^2 - 4x - 13$  D)  $4x^2 - 32$

Answer: D

- 394)  $f \circ g$  for  $f(x) = \frac{3}{8}x$  and  $g(x) = -\frac{8}{3}x$   
 A) 0 B)  $-x$  C) 1 D)  $x$

Answer: B

- 395)  $f \circ g$  for  $f(x) = \frac{7}{x-2}$  and  $g(x) = \frac{7}{6x}$   
 A)  $\frac{7x-14}{42x}$  B)  $\frac{7x}{7-12x}$  C)  $\frac{42x}{7+12x}$  D)  $\frac{42x}{7-12x}$

Answer: D

- 396)  $g \circ f$  for  $f(x) = \frac{x-4}{7}$  and  $g(x) = 7x + 4$   
 A)  $x$  B)  $x + 8$  C)  $7x + 24$  D)  $x - \frac{4}{7}$

Answer: A

397)  $f \circ g$  for  $f(x) = \sqrt{x+5}$  and  $g(x) = 8x - 9$   
 A)  $2\sqrt{2x-1}$  B)  $8\sqrt{x+5-9}$

Answer: A

C)  $8\sqrt{x-4}$

D)  $2\sqrt{2x+1}$

398)  $g \circ f$  for  $f(x) = 4x^2 + 2x + 5$  and  $g(x) = 2x - 6$   
 A)  $4x^2 + 2x - 1$  B)  $4x^2 + 4x + 4$

Answer: D

C)  $8x^2 + 4x + 16$

D)  $8x^2 + 4x + 4$

399)  $g \circ f$  for  $f(x) = \frac{4}{7x^5}$  and  $g(x) =$

A)  $\frac{4}{7x^5}$

B)  $\frac{7168}{x^5}$

C)  $\frac{7x^5}{4}$

D)  $\frac{7x^5}{1024}$

Answer: B

400)  $g \circ f$  for  $f(x) = x^3 + 3$  and  $g(x) = \sqrt[3]{x-3}$   
 A)  $|x|$  B)  $x$

Answer: B

C)  $-x$

D)  $x^3$

Find the domain of the composite function  $f \circ g$ .

401)  $f(x) = x^2 - 1$ ,  $g(x) = 2x + 3$   
 A)  $(-\infty, \infty)$  B)  $(-1, 1)$

Answer: A

C)  $[0, \infty)$

D)  $[1, \infty)$

402)  $f(x) = \frac{1}{x-6}$ ,  $g(x) = \sqrt{x+1}$

A)  $[-1, 6) \cup (6, \infty)$

B)  $[0, 35) \cup (35, \infty)$

C)  $[0, 6) \cup (6, \infty)$

D)  $[-1, 35) \cup (35, \infty)$

Answer: D

403)  $f(x) = 6x + 60$ ,  $g(x) = x + 6$   
 A)  $(-\infty, \infty)$   
 C)  $(-\infty, -16) \cup (-16, \infty)$

Answer: A

B)  $(-\infty, -10) \cup (-10, -6) \cup (-6, \infty)$

D)  $(-\infty, 16) \cup (16, \infty)$

404)  $f(x) = \frac{3}{x+10}$ ,  $g(x) = x + 2$

A)  $(-\infty, -10) \cup (-10, \infty)$

C)  $(-\infty, \infty)$

B)  $(-\infty, -10) \cup (-10, -2) \cup (-2, \infty)$

D)  $(-\infty, -12) \cup (-12, \infty)$

Answer: D

405)  $f(x) = x + 4$ ,  $g(x) = \frac{3}{x+5}$

A)  $(-\infty, -5) \cup (-5, \infty)$

C)  $(-\infty, -5) \cup (-5, -4) \cup (-4, \infty)$

B)  $(-\infty, \infty)$

D)  $(-\infty, -9) \cup (-9, \infty)$

Answer: A

$$406) f(x) = \frac{1}{x+5}, g(x) = \frac{10}{x}$$

A)  $(-\infty, \infty)$

C)  $(-\infty, 0) \cup (0, -2) \cup (-2, \infty)$

Answer: C

B)  $(-\infty, -5) \cup (-5, 0) \cup (0, \infty)$

D)  $(-\infty, -5) \cup (-5, -2) \cup (-2, 0) \cup (0, \infty)$

$$407) f(x) = \sqrt{x}, g(x) = 2x + 12$$

A)  $[-6, \infty)$

Answer: A

B)  $(-\infty, -6] \cup [0, \infty)$

C)  $[0, \infty)$

D)  $(-\infty, \infty)$

$$408) f(x) = 6x + 36, g(x) = \sqrt{x}$$

A)  $[0, \infty)$

Answer: A

B)  $(-\infty, \infty)$

C)  $(-\infty, -6] \cup [0, \infty)$

D)  $[-6, \infty)$

Express the given function H as a composition of two functions f and g such that  $H(x) = (f \circ g)(x)$ .

$$409) H(x) = \frac{1}{x^2 - 3}$$

A)  $f(x) = \frac{1}{x^2}, g(x) = x - \frac{1}{3}$

C)  $f(x) = \frac{1}{x^2}, g(x) = x - 3$

Answer: D

B)  $f(x) = \frac{1}{3}, g(x) = x^2 - 3$

D)  $f(x) = \frac{1}{x}, g(x) = x^2 - 3$

$$410) H(x) = |9x + 10|$$

A)  $f(x) = |x|, g(x) = 9x + 10$

C)  $f(x) = |x|, g(x) = 9x + 10$

Answer: C

B)  $f(x) = x, g(x) = 9x + 10$

D)  $f(x) = |x|, g(x) = 9x - 10$

$$411) H(x) = \frac{1}{x^2} + 5$$

A)  $f(x) = \frac{1}{x^2}, g(x) = 5$

C)  $f(x) = x, g(x) = \frac{1}{x} + 5$

Answer: D

B)  $f(x) = \frac{1}{x}, g(x) = \frac{1}{x} + 5$

D)  $f(x) = x + 5, g(x) = \frac{1}{x^2}$

$$412) H(x) = \frac{8}{\sqrt{4x+9}}$$

A)  $f(x) = 8, g(x) = \sqrt{4x+9}$

C)  $f(x) = \sqrt{4x+9}, g(x) = 8$

Answer: D

B)  $f(x) = \frac{8}{x}, g(x) = 4x + 9$

D)  $f(x) = \frac{8}{\sqrt{x}}, g(x) = 4x + 9$

413)  $H(x) = (3x - 3)^7$

A)  $f(x) = 3x^7, g(x) = x - 3$

C)  $f(x) = (3x)^7, g(x) = -3$

B)  $f(x) = 3x - 3, g(x) = x^7$

D)  $f(x) = x^7, g(x) = 3x - 3$

Answer: D

414)  $H(x) = \sqrt{8x^2 + 66}$

A)  $f(x) = 8x^2 + 66, g(x) = \sqrt{x}$

C)  $f(x) = \sqrt{8x^2}, g(x) = \sqrt{66}$

B)  $f(x) = \sqrt{x}, g(x) = 8x^2 + 66$

D)  $f(x) = \sqrt{8x + 66}, g(x) = x^2$

Answer: B

415)  $H(x) = \sqrt{3 - \sqrt{x - 3}}$

A)  $f(x) = \sqrt{x - 3}, g(x) = \sqrt{x - 3}$

C)  $f(x) = \sqrt{3 - x}, g(x) = \sqrt{x - 3}$

B)  $f(x) = \sqrt{3 + x}, g(x) = \sqrt{x - 3}$

D)  $f(x) = \frac{\sqrt{x - 3}, g(x) = \sqrt{3 - x}}{x}$

Answer: C

Solve the problem.

416) Suppose that  $P(x)$  represents the percentage of income spent on housing in year  $x$  and  $I(x)$  represents income

in year  $x$ . Determine a function  $H$  that represents total housing expenditures in year  $x$ .

A)  $H(x) = \left(\frac{I}{P}\right)(x)$

B)  $H(x) = (P + I)(x)$

C)  $H(x) = (P \cdot I)(x)$

D)  $H(x) = (I - P)(x)$

Answer: C

417) A balloon (in the shape of a sphere) is being inflated. The radius is increasing at a rate of 11 cm per second. Find a function,  $r(t)$ , for the radius in terms of  $t$ . Find a function,  $V(r)$ , for the volume of the balloon in terms of  $r$ . Find  $(V \circ r)(t)$ .

A)  $(V \circ r)(t) = \frac{5324\pi t^3}{3}$

B)  $(V \circ r)(t) = \frac{6655\pi t^2}{3}$

C)  $(V \circ r)(t) = \frac{58564\pi\sqrt{t}}{3}$

D)  $(V \circ r)(t) = \frac{847\pi t^3}{3}$

Answer: A

418) At Allied Electronics, production has begun on the X-15 Computer Chip. The total revenue function is given by  $R(x) = 53x - 0.3x^2$  and the total cost function is given by  $C(x) = 2x + 8$ , where  $x$  represents the number of boxes of computer chips produced. The total profit function,  $P(x)$ , is such that  $P(x) = R(x) - C(x)$ . Find  $P(x)$ .

A)  $P(x) = 0.3x^2 + 49x - 24$

B)  $P(x) = -0.3x^2 + 51x - 8$

C)  $P(x) = 0.3x^2 + 51x - 16$

D)  $P(x) = -0.3x^2 + 49x + 8$

Answer: B

419) At Allied Electronics, production has begun on the X-15 Computer Chip. The total revenue function is given by  $R(x) = 46x - 0.3x^2$  and the total profit function is given by  $P(x) = -0.3x^2 + 34x - 15$ , where  $x$  represents the number of boxes of computer chips produced. The total cost function,  $C(x)$ , is such that  $C(x) = R(x) - P(x)$ . Find  $C(x)$ .

A)  $C(x) = -0.3x^2 + 24x + 15$

B)  $C(x) = 13x + 20$

C)  $C(x) = 12x + 15$

D)  $C(x) = 14x + 11$

Answer: C

420) At Allied Electronics, production has begun on the X-15 Computer Chip. The total cost function is given by  $C(x) = 8x + 12$  and the total profit function is given by  $P(x) = -0.3x^2 + 51x - 12$ , where  $x$  represents the number of boxes of computer chips produced. The total revenue function,  $R(x)$ , is such that  $R(x) = C(x) + P(x)$ . Find  $R(x)$ .

- A)  $R(x) = 58x - 0.6x^2$       B)  $R(x) = 59x - 0.3x^2$       C)  $R(x) = 61x - 0.3x^2$       D)  $R(x) = 59x + 0.3x^2$

Answer: B

421) A stone is thrown into a pond. A circular ripple is spreading over the pond in such a way that the radius is increasing at the rate of 6.5 feet per second. Find a function,  $r(t)$ , for the radius in terms of  $t$ . Find a function,  $A(r)$ , for the area of the ripple in terms of  $r$ . Find  $(A \circ r)(t)$ .

- A)  $(A \circ r)(t) = 6.5\pi t^2$       B)  $(A \circ r)(t) = 42.25\pi t^2$   
 C)  $(A \circ r)(t) = 42.25\pi^2 t$       D)  $(A \circ r)(t) = 13\pi t^2$

Answer: B

422) Ken is 6 feet tall and is walking away from a streetlight. The streetlight has its light bulb 14 feet above the ground, and Ken is walking at the rate of 3.2 feet per second. Find a function,  $d(t)$ , which gives the distance Ken is from the streetlight in terms of time. Find a function,  $S(d)$ , which gives the length of Ken's shadow in terms of  $d$ . Then find  $(S \circ d)(t)$ .

- A)  $(S \circ d)(t) = 3.04t$       B)  $(S \circ d)(t) = 2.4t$       C)  $(S \circ d)(t) = 5.41t$       D)  $(S \circ d)(t) = 1.76t$

Answer: B

423) The following graph shows the private, public and total national school enrollment for students for select years from 1970 through 2000.

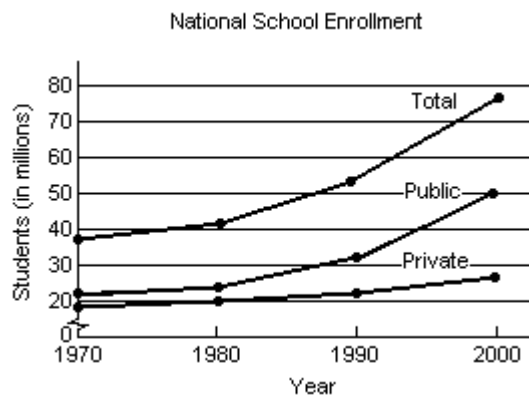

- i) How is the graph for total school enrollment,  $T$ , determined from the graph of the private enrollment,  $r$ , and the public enrollment,  $u$ ?
- ii) During which 10-year period did the total number of students enrolled increase the least?
- iii) During which 10-year period did the total number of students enrolled increase the most?
- A) i)  $T$  is the difference of  $r$  and  $u$ .      B) i)  $T$  is the sum of  $r$  and  $u$ .  
 ii) 1970 - 1980      ii)  $u$ .  
 iii) 1990-2000      iii) 1990-2000
- C) i)  $T$  is the sum of  $r$  and  $u$ .      D) i)  $T$  is the sum of  $r$  and  $u$ .  
 ii) 1970 - 1980      ii)  $u$ .  
 iii) 1980-1990      iii) 1970-1980

Answer: B

424) A firm is considering a new product. The accounting department estimates that the total cost,  $C(x)$ , of producing  $x$  units will be

$$C(x) = 60x + 7650.$$

The sales department estimates that the revenue,  $R(x)$ , from selling  $x$  units will be

$$R(x) = 70x,$$

but that no more than 945 units can be sold at that price. Find and interpret  $(R - C)(945)$ .

A) \$130,500 profit, income exceeds cost

It is worth it to develop product.

C) \$1710 profit, income exceeds cost

It is worth it to develop product.

B) -\$1800 loss, cost exceeds income

It is not worth it to develop product.

D) \$1800 profit, income exceeds cost

It is worth it to develop product.

Answer: D

425) The function  $f(t) = -0.12t^2 + 0.5t + 30.3$  models the U.S. population in millions, ages 65 and older, where  $t$  represents years after 1990. The function  $g(t) = 0.56t^2 + 12.23t + 106.3$  models the total yearly cost of Medicare in billions of dollars, where  $t$  represents years after 1990. What does the function  $g$  represent?

Find  $g(5)$ .

f

f

A) Cost per person in thousands of dollars. \$0.16

thousand B) Cost per person in thousands of dollars.

\$0.20 thousand C) Cost per person in thousands of

dollars. \$13.66 thousand D) Cost per person in thousands

of dollars. \$6.09 thousand

Answer: D

Using the horizontal-line test, determine whether the function is one-to-one.

426)

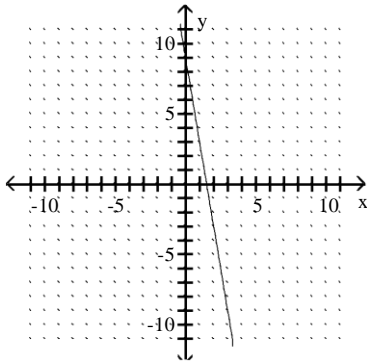

A) one-to-one

B) not one-to-one

Answer: A



427)

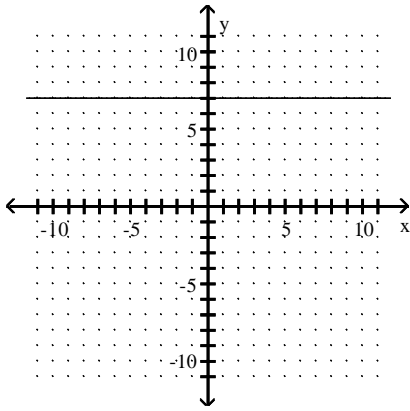

A) one-to-one

B) not one-to-one

Answer: B

428)

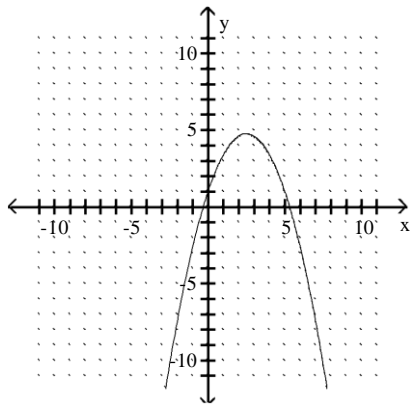

A) one-to-one

B) not one-to-one

Answer: B

429)

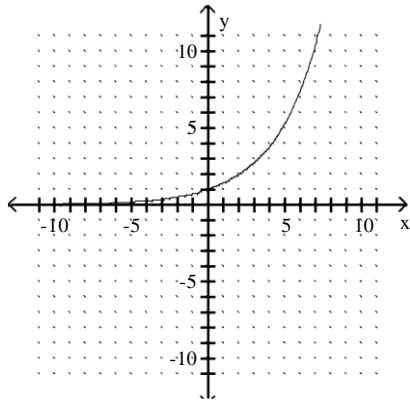

A) one-to-one

B) not one-to-one

Answer: A

430)

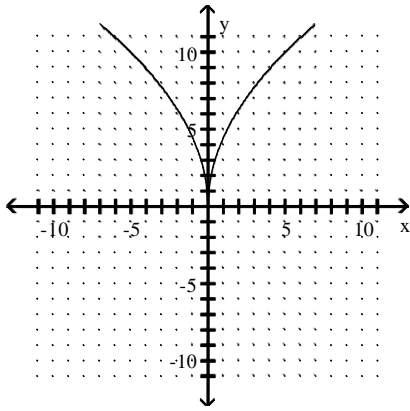

A) one-to-one

B) not one-to-one

Answer: B

431)

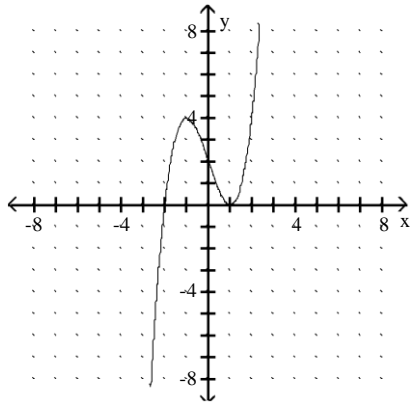

A) one-to-one

B) not one-to-one

Answer: B

432)

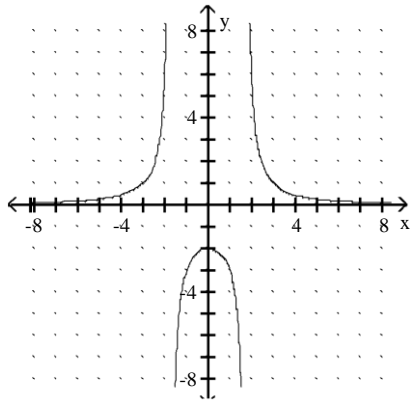

A) one-to-one

B) not one-to-one

Answer: B

433)

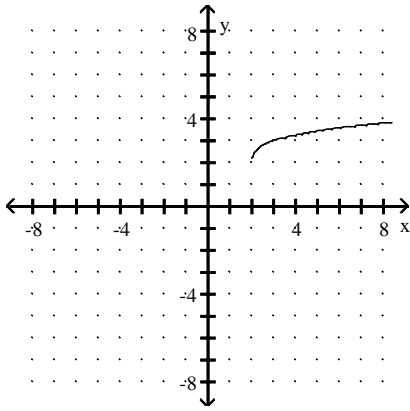

A) one-to-one

B) not one-to-one

Answer: A

434)

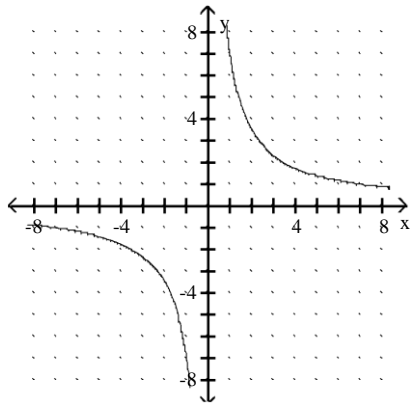

A) one-to-one

B) not one-to-one

Answer: A

435)

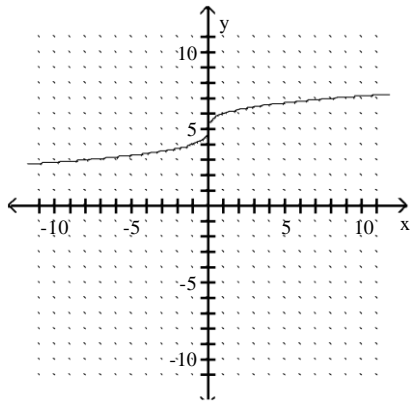

A) one-to-one

B) not one-to-one

Answer: A

Assume the functions are one-to-one. Find the requested inverse.

436) If  $f(6) = 2$ , find  $f^{-1}(2)$

A) -1

B) 2

C) 6

D) 9

Answer: C

437) If  $g(-5) = 5$ , find  $g^{-1}(5)$

A) 6

B) 1

C) -5

D) 5

Answer: C

438) Find  $(f \circ f^{-1})(5)$

A) 5

B) 1

C) -1

D) 3

Answer: A

SHORT ANSWER. Write the word or phrase that best completes each statement or answers the question.

Show that  $f$  and  $g$  are inverses of each other by verifying that  $f(g(x)) = x = g(f(x))$ .

439)  $f(x) = 6x$ ;  $g(x) = \frac{x}{6}$

Answer:  $f(g(x)) = f\left(\frac{x}{6}\right) = 6 \cdot \frac{x}{6} = x$

$$g(f(x)) = g(6x) = \frac{6x}{6} = x$$

440)  $f(x) = \frac{x+2}{3}$ ;  $g(x) = 3x - 2$

Answer:  $f(g(x)) = f(3x - 2) = \frac{(3x - 2) + 2}{3} = \frac{3x}{3} = x$

$$g(f(x)) = g\left(\frac{x+2}{3}\right) = 3\left(\frac{x+2}{3}\right) - 2 = (x+2) - 2 = x$$

441)  $f(x) = \sqrt{x}$ ;  $g(x) = x^2$

Answer:  $f(g(x)) = f(x^2) = \sqrt{x^2} = x$

$$g(f(x)) = g(\sqrt{x}) = (\sqrt{x})^2 =$$

$x$

442)  $f(x) = \sqrt{9-x}$ ;  $g(x) = 9-x^2$

Answer:  $f(g(x)) = f(9-x^2) = \sqrt{9-(9-x^2)} = \sqrt{9-9+x^2} = \sqrt{x^2} = x$

$$g(f(x)) = g(\sqrt{9-x}) = 9 - (\sqrt{9-x})^2 = 9 - (9-x) = 9 - 9 + x =$$

$x$

443)  $f(x) = x^3 - 1$ ;  $g(x) = \sqrt[3]{x+1}$

Answer:  $f(g(x)) = \left(\sqrt[3]{x+1}\right)^3 - 1 = x + 1 - 1 = x$

$f$

$$g(f(x)) = \sqrt[3]{x^3 - 1} + 1 = \sqrt[3]{x^3} = x$$

444)  $f(x) = \sqrt[3]{x+7}$ ;  $g(x) = x^3 - 7$

Answer:  $f(g(x)) = f(x^3 - 7) = \sqrt[3]{(x^3 - 7) + 7} = \sqrt[3]{x^3} = x$   
 $=$

$g(f(x)) = g(\sqrt[3]{x+7}) = (\sqrt[3]{x+7})^3 - 7 = x + 7 - 7 = x$

445)  $f(x) = \frac{1+x}{x}$ ;  $g(x) = \frac{1}{x-1}$

Answer:  $f(g(x)) = f\left(\frac{1}{x-1}\right) = \frac{1 + \frac{1}{x-1}}{\frac{1}{x-1}} = \frac{\frac{1(x-1) + 1}{x-1}}{\frac{1}{x-1}} = \frac{1(x-1) + 1}{1} = \frac{1x - 1 + 1}{1} = \frac{1x}{1} = x$

$g(f(x)) = g\left(\frac{1+x}{x}\right) = \frac{1}{\frac{1+x}{x} - 1} = \frac{1}{\frac{1+x-x}{x}} = \frac{1}{\frac{1}{x}} = 1 \cdot \frac{x}{1} = x$

MULTIPLE CHOICE. Choose the one alternative that best completes the statement or answers the question.

The graph of a function  $f$  is given. On the same axes, sketch the graph of  $f^{-1}$ .

446)

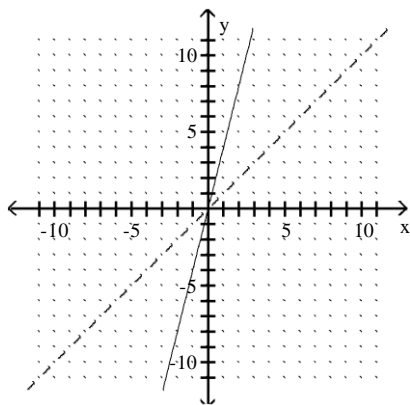

A)

B)

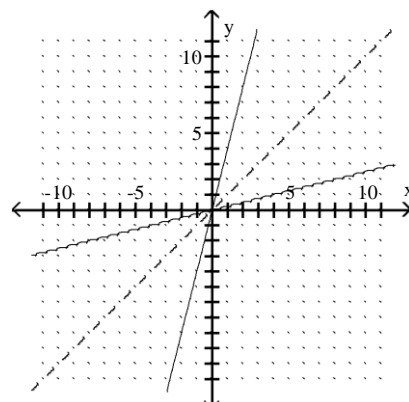
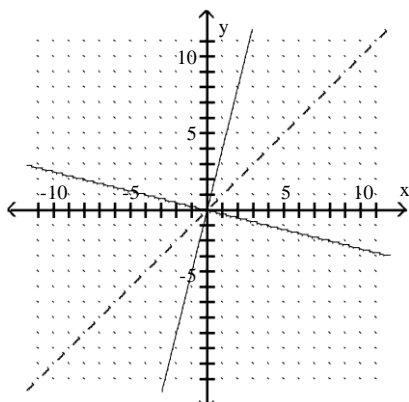

Answer: B

447)

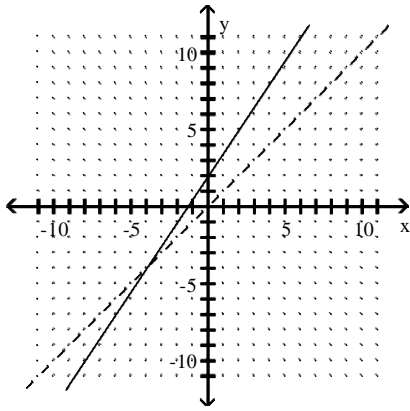

A)

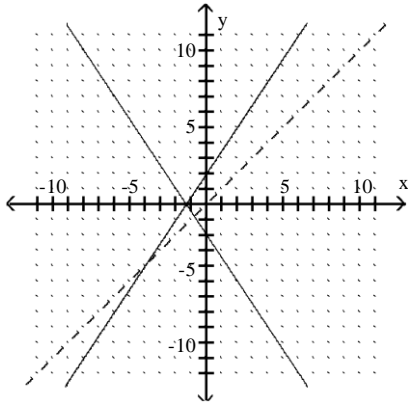

B)

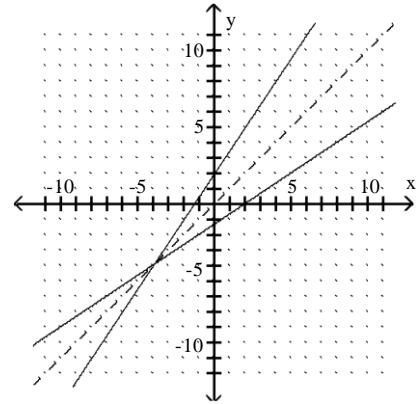

Answer: B



448)

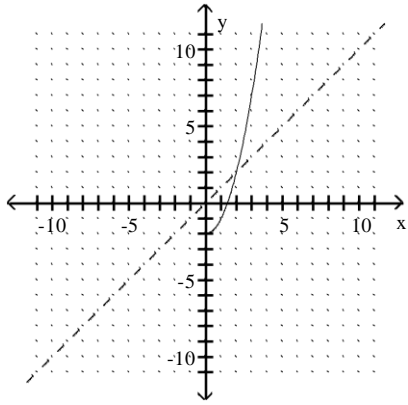

A)

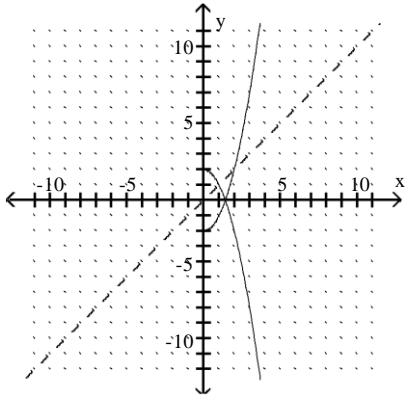

B)

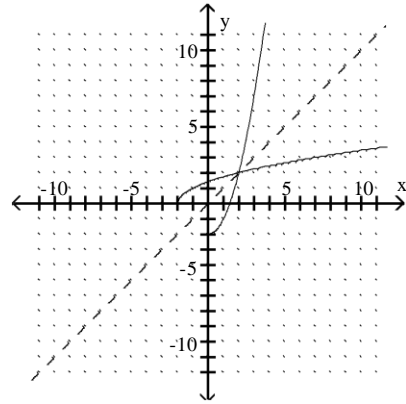

Answer: B

449)

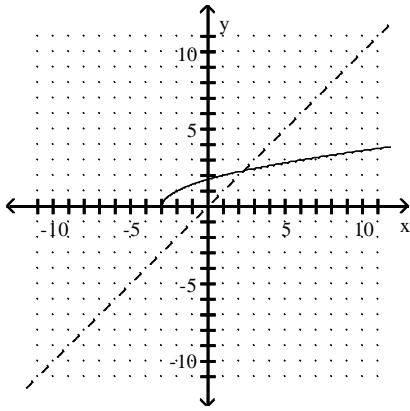

A)

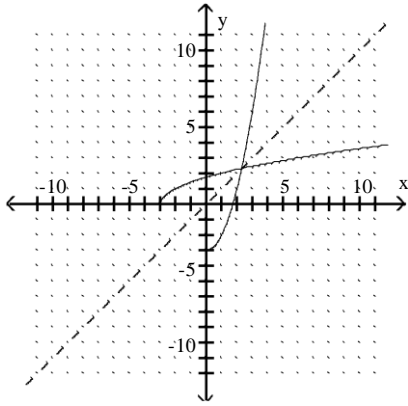

B)

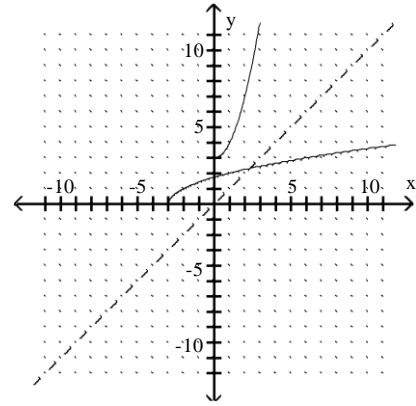

Answer: A

450)

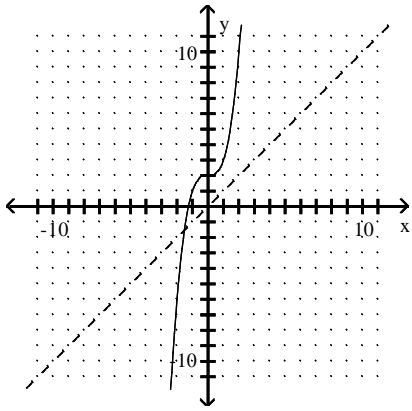

A)

B)

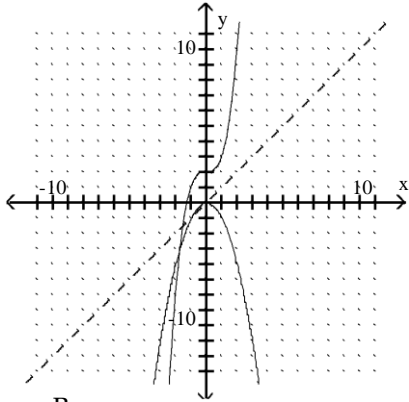

Answer: B

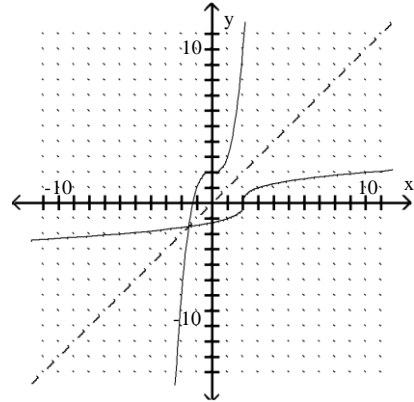

451)

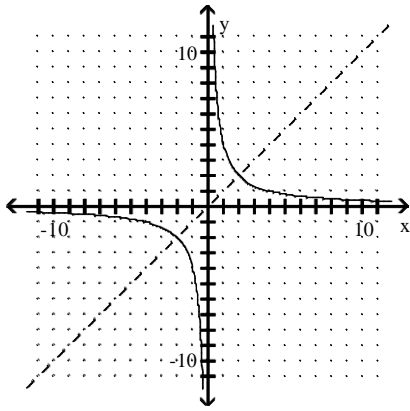

A)

B)

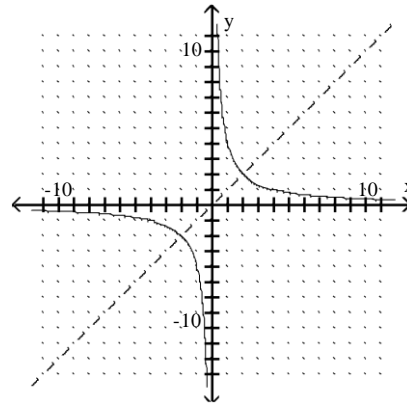
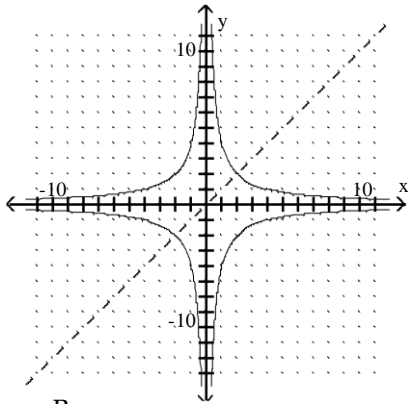

Answer: B

452)

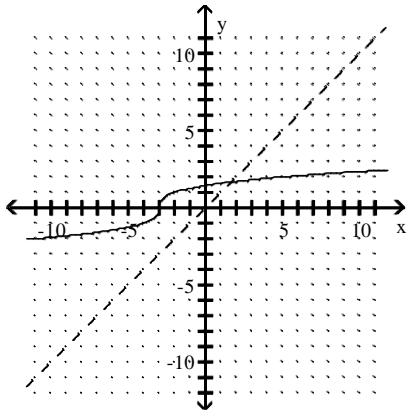

A)

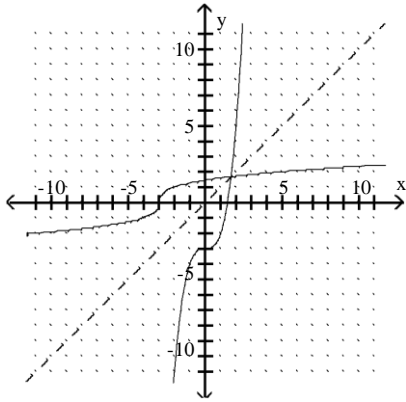

B)

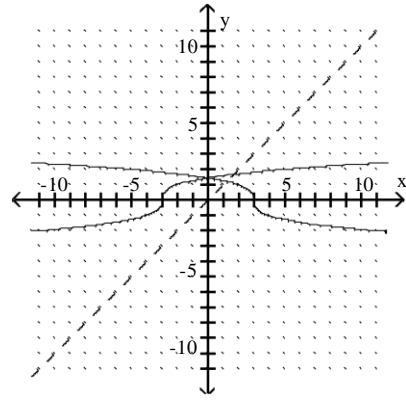

Answer: A

453)

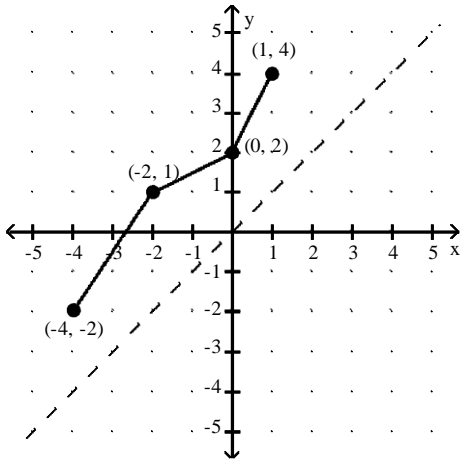

A)

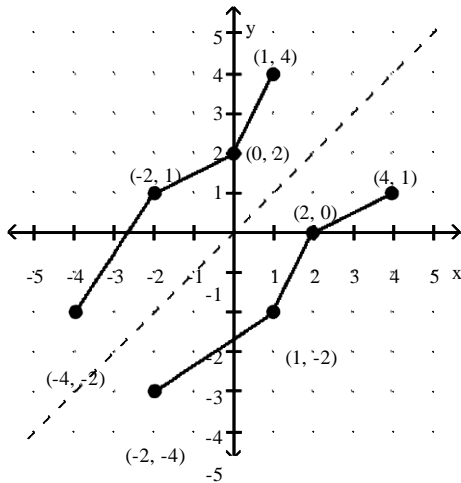

B)

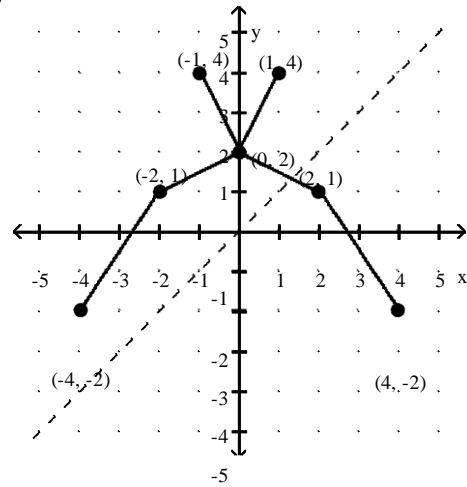

Answer: A

Determine whether the given function is one-to-one. If it is one-to-one, find its inverse.

454)  $f(x) = 5 - x$

A)  $f^{-1}(x) = \frac{x}{5}$

B)  $f^{-1}(x) = 5 - x$

C)  $f^{-1}(x) = x - 5$

D)  $f^{-1}(x) = x + 5$

Answer: B

455)  $f(x) = 7x - 63$

A)  $f^{-1}(x) = \frac{1}{7}x + 9$

B)  $f^{-1}(x) = \frac{1}{9}x + 7$

C)  $f^{-1}(x) = 7x + 63$

D)  $f^{-1}(x) = \frac{1}{x}$

Answer: A

456)  $f(x) = 6x + 2$

A)  $f^{-1}(x) = \frac{x-2}{6}$

B)  $f^{-1}(x) = \frac{x+2}{6}$

C) Not one-to-one

D)  $f^{-1}(x) = \frac{x}{6} - 2$

Answer: A

$$457) f(x) = -\frac{4}{0x}, x \neq$$

$$A) f^{-1}(x) = -\frac{x}{4}$$

$$B) f^{-1}(x) = \frac{4}{x}$$

$$C) f^{-1}(x) = -\frac{4}{x}$$

$$D) f^{-1}(x) = -4x$$

Answer: C

$$458) f(x) = \frac{6}{x-2}$$

$$A) f^{-1}(x) = \frac{x}{-2+6x}$$

$$B) f^{-1}(x) = \frac{2x+6}{x}$$

$$C) f^{-1}(x) = \frac{-2+6x}{x}$$

D) Not one-to-one

Answer: B

$$459) f(x) = \sqrt{x-4}$$

$$A) f^{-1}(x) = \sqrt{x+4}$$

B) Not one-to-one

$$C) f^{-1}(x) = x^2 + 4, x \geq 0$$

$$D) f^{-1}(x) = (x-4)^2$$

Answer: C

$$460) f(x) = x\sqrt{5-x^2}$$

A) Not one-to-one

$$B) f^{-1}(x) = x^3 - 5$$

$$C) f^{-1}(x) = \sqrt{5-x^2}$$

$$D) f^{-1}(x) = x^2 + 5$$

Answer: A

$$461) f(x) = \sqrt[3]{x-9}$$

$$A) f^{-1}(x) = (x-9)^3$$

$$B) f^{-1}(x) = (x+9)^3$$

$$C) f^{-1}(x) = x^3 + 9$$

$$D) f^{-1}(x) = \sqrt[3]{x+9}$$

Answer: B

$$462) f(x) = \sqrt[3]{x-9}$$

$$A) f^{-1}(x) = x^3 + 9$$

$$B) f^{-1}(x) = \sqrt[3]{x-9}$$

$$C) f^{-1}(x) = (x-9)^3$$

$$D) f^{-1}(x) = (x+9)^3$$

Answer: A

$$463) f(x) = 7x^2 + 6, x \geq 0$$

$$A) f^{-1}(x) = \sqrt{\frac{x-6}{7}}$$

$$B) f^{-1}(x) = \sqrt{\frac{x-6}{7}}$$

C) Not one-to-one

$$D) f^{-1}(x) = \frac{7}{\sqrt{x-6}}$$

Answer: B

Sketch the graph of the function and its inverse on the same coordinate axes.

464)  $f(x) = 5x$

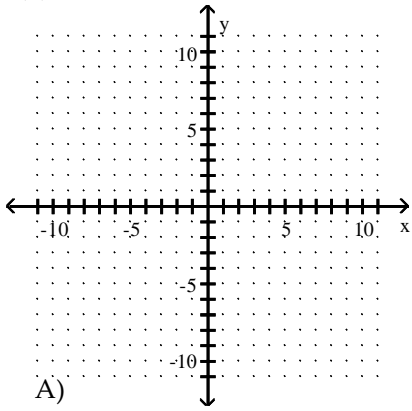

A)

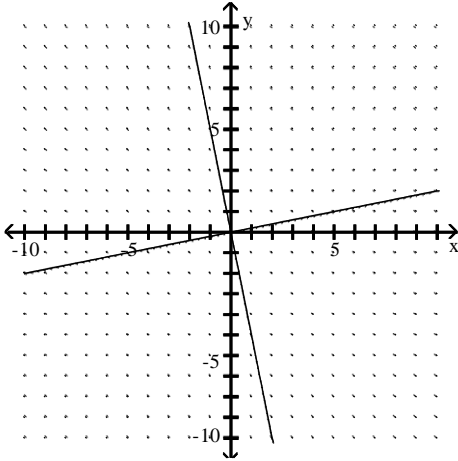

C)

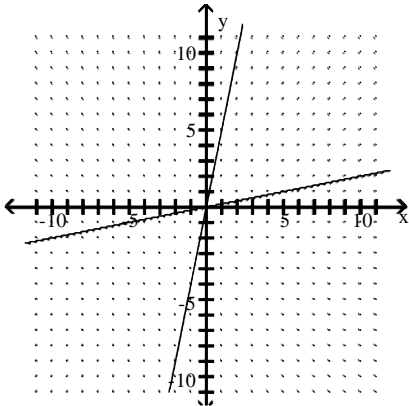

B)

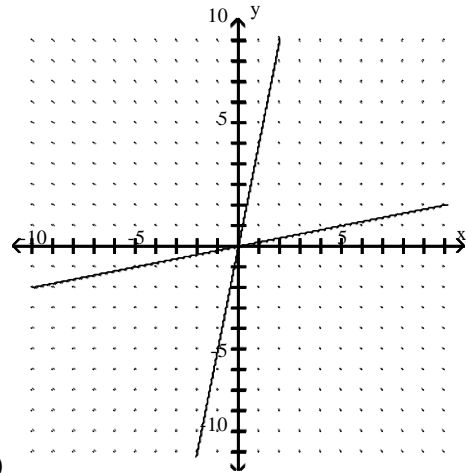

D)

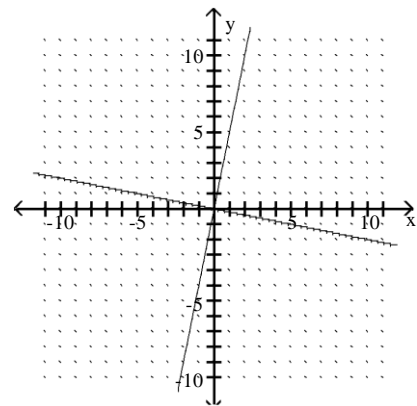

Answer: C



465)  $f(x) = 2x + 3$

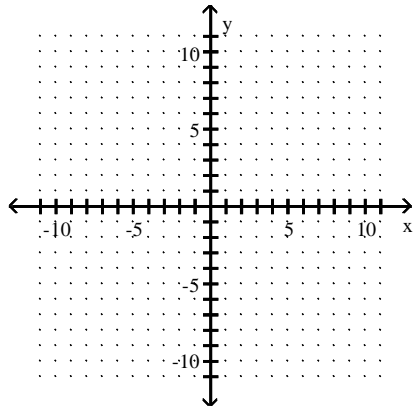

A)

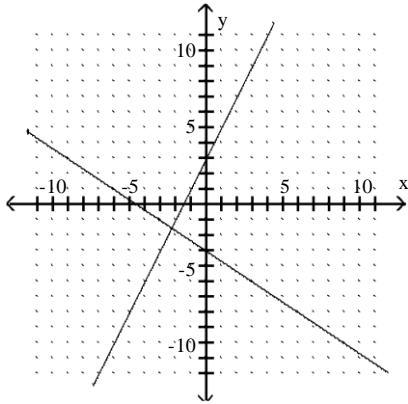

B)

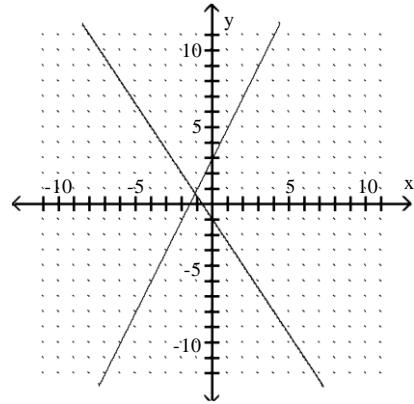

C)

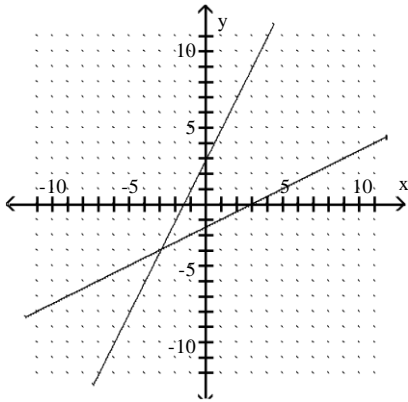

D)

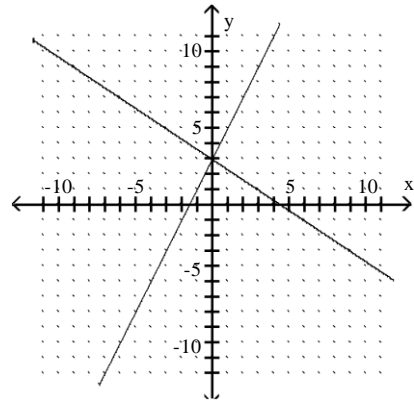

Answer: C

466)  $y = \sqrt{x+3}$

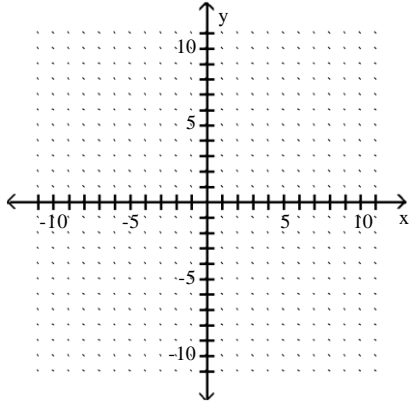

A)

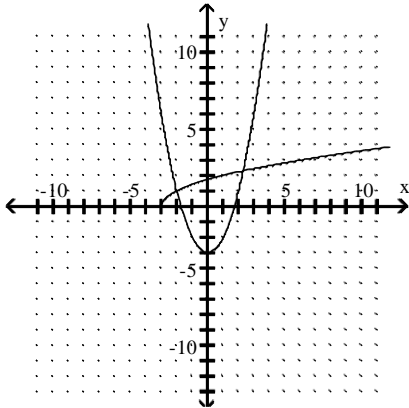

B)

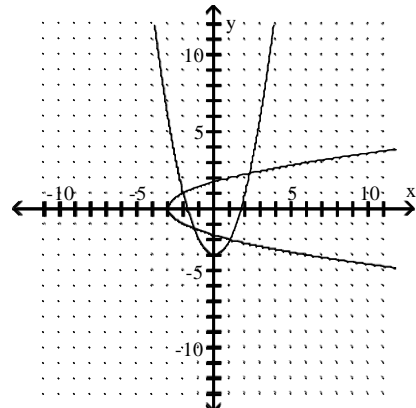

C)

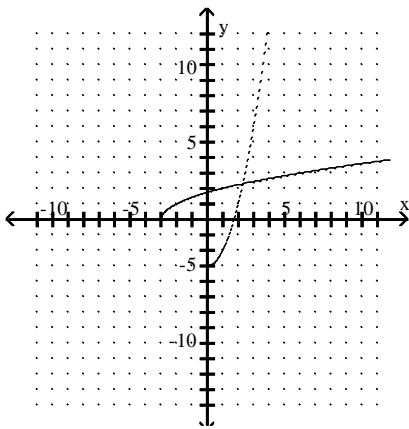

D)

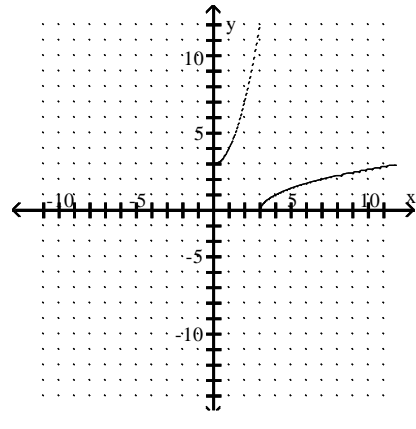

Answer: C

467)  $y = x^3 + 4$

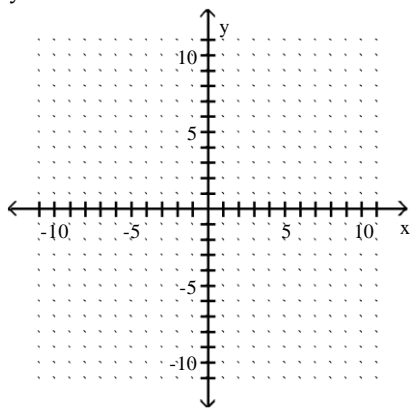

A)

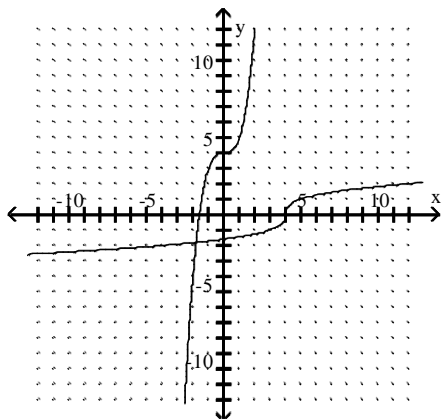

B)

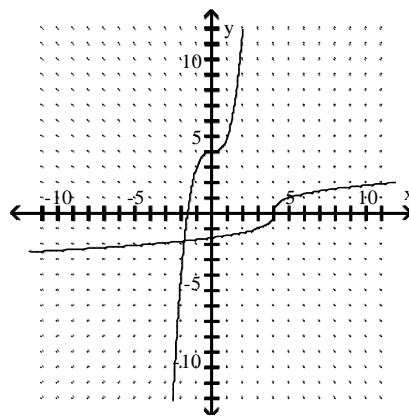

C)

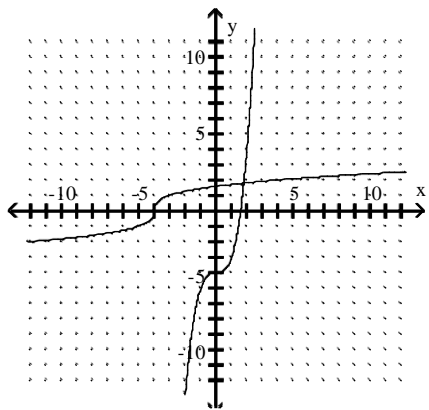

D)

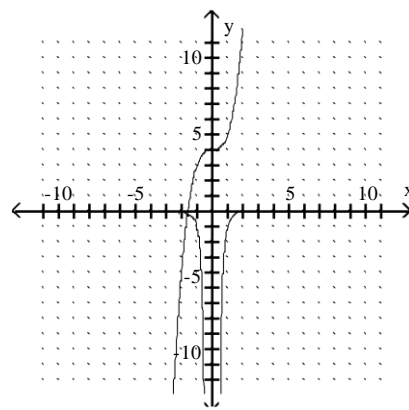

Answer: B

468)  $f(x) = \frac{6}{x+6}$

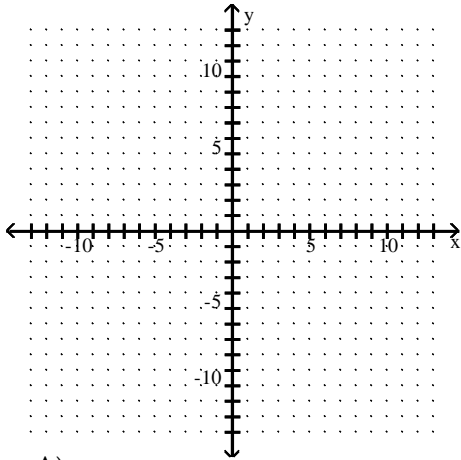

A)

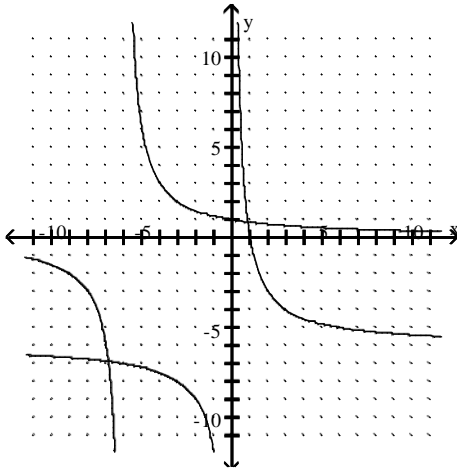

B)

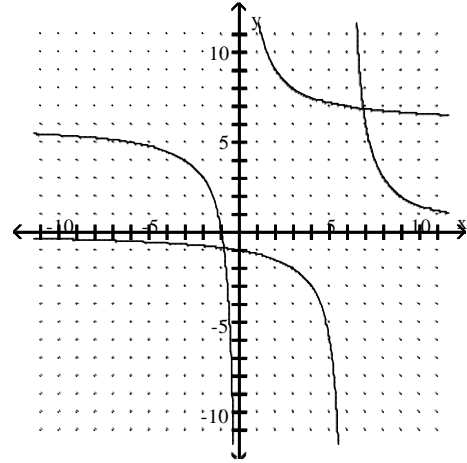

C)

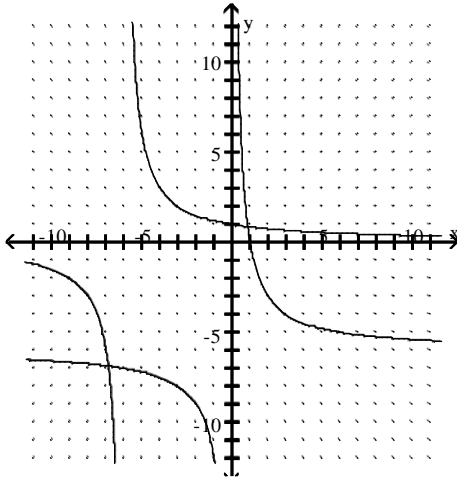

D)

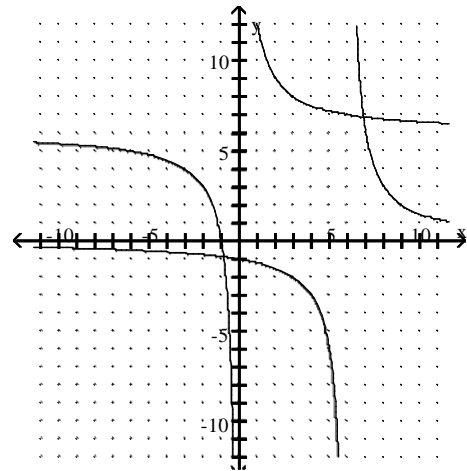

Answer: C

469)  $f(x) = 3 - x^2$  for  $x \leq 0$

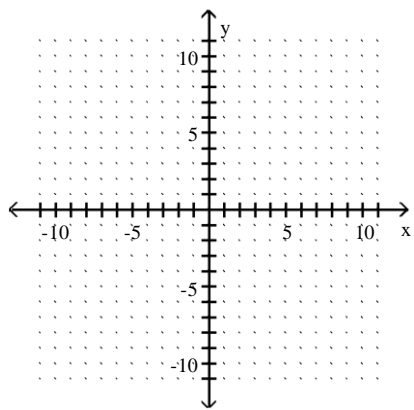

A)

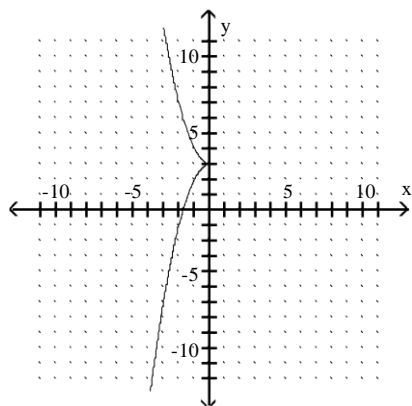

B)

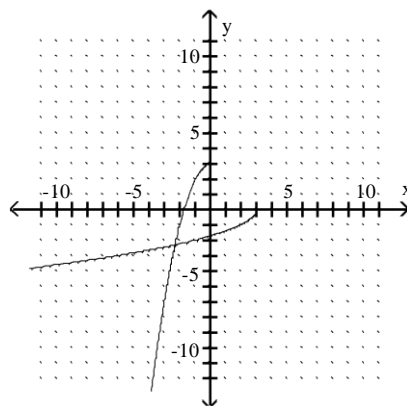

C)

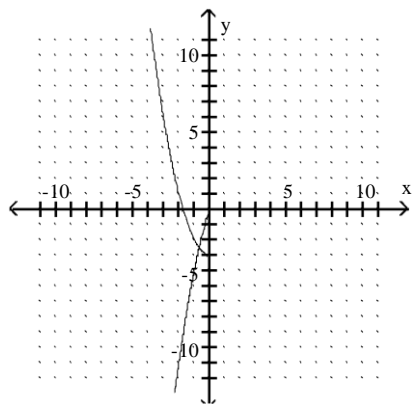

D)

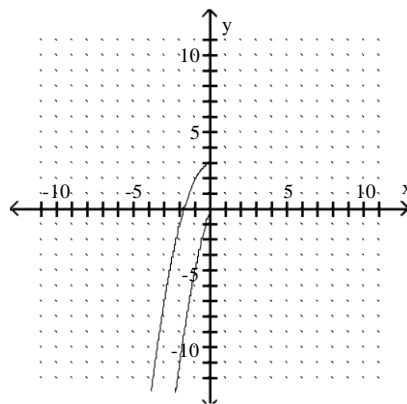

Answer: B

470)  $f(x) = (x + 4)^3$

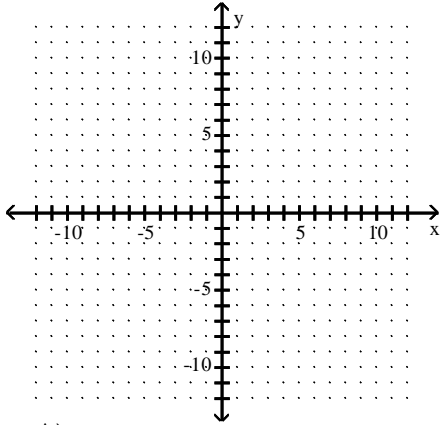

A)

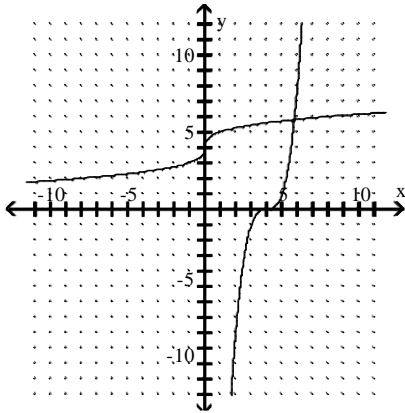

B)

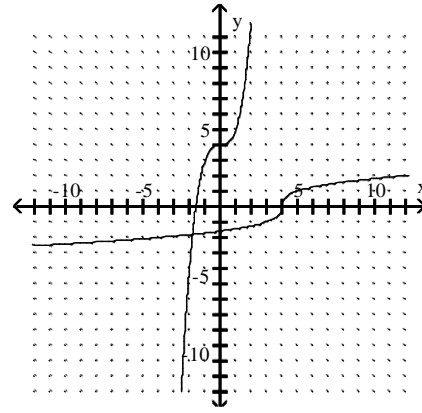

C)

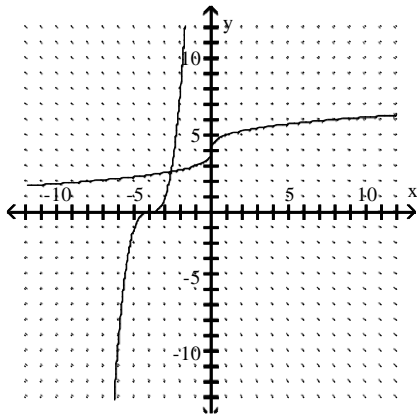

D)

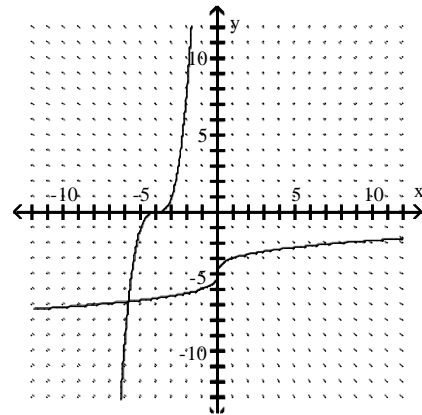

Answer: D

Solve the problem.

471) A size 6 dress in Country C is size 32 in Country D. A function that converts dress sizes in Country C to those in

Country D is  $f(x) = x + 26$ . Find the inverse of the function.

A)  $f^{-1}(x) = x - 26$

B)  $f^{-1}(x) = x + 26$

C)  $f^{-1}(x) = \frac{x}{26}$

D)  $f^{-1}(x) = \frac{x}{-26}$

Answer: A

472) A size 34 dress in Country C is size 5 in Country D. A function that converts dress sizes in Country C to those in

Country D is  $f(x) = \frac{x}{2} - 12$ . Find the inverse of the function.

- A)  $f^{-1}(x) = x + 12$       B)  $f^{-1}(x) = 2(x + 12)$       C)  $f^{-1}(x) = 2x + 12$       D)  $f^{-1}(x) = 2(x - 12)$   
 Answer: B

473) A size 4 dress in Country C is size 40 in Country D. A function that converts dress sizes in Country C to those in

Country D is  $f(x) = 2(x + 16)$ . Find the inverse of the function.

- A)  $f^{-1}(x) = \frac{x}{2} - 16$       B)  $f^{-1}(x) = x - 16$       C)  $f^{-1}(x) = \frac{x}{2} + 16$       D)  $f^{-1}(x) = \frac{x-16}{2}$

Answer: A

474)  $32^\circ$  Fahrenheit =  $0^\circ$  Celsius. A function that converts temperatures in Fahrenheit to those in Celsius is  $f(x) = \frac{5}{9}(x - 32)$ . Find the inverse of the function.

- A)  $f^{-1}(x) = \frac{9}{5}x + 32$       B)  $f^{-1}(x) = x + 32$       C)  $f^{-1}(x) = \frac{9}{5}x - 32$       D)  $f^{-1}(x) = \frac{5}{9}(x - 32)$

Answer: A

475) An organization determines that the cost per person of chartering a bus is given by the formula

$$C(x) = \frac{250+5x}{x},$$

where  $x$  is the number of people in the group and  $C(x)$  is in dollars. Find the inverse of the function.

- A)  $C^{-1}(x) = \frac{250}{x-5}$       B)  $C^{-1}(x) = \frac{250+x}{5}$       C)  $C^{-1}(x) = \frac{250}{x+5}$       D)  $C^{-1}(x) = \frac{5}{x-250}$

Answer: A

476) Let  $f(x)$  compute the time in hours to travel  $x$  miles at 35 miles per hour. What does  $f^{-1}(x)$  compute?

- A) The miles traveled in  $x$  hours      B) The hours taken to travel  $x$  miles  
 C) The hours taken to travel 35 miles      D) The miles traveled in 35 hours

Answer: A

477) Let  $f(x)$  compute the time in hours to travel  $x$  miles at 57 miles per hour. What is the interpretation of  $f^{-1}(7)$ ?

- A) The hours taken to travel 57 miles      B) The miles traveled in 7 hours  
 C) The hours taken to travel 7 miles      D) The miles traveled in 57 hours

Answer: B

478) Let  $f(x)$  compute the cost of a rental car after  $x$  days of use at \$34 per day. What does  $f^{-1}(x)$  compute?

- A) The number of days rented for 34 dollars      B) The number of days rented for  $x$  dollars  
 C) The cost of rental for 34 days      D) The cost of rental for  $x$  dollars

Answer: B

479) Let  $f(x)$  compute the cost of a rental car after  $x$  days of use at \$26 per day. What is the interpretation of the solution of  $f^{-1}(x) = 141$ ?

- A) The number of days rented for \$26
- C) The cost of rental for 26 days

- B) The cost of rental for 141 days
- D) The number of days rented for \$141

Answer: B



480) To remodel a bathroom, a contractor charges \$25 per hour plus material costs, which amount to \$3650. Therefore, the total cost to remodel the bathroom is given by  $f(x) = 25x + 3650$  where  $x$  is the number of hours the contractor works. Find  $f^{-1}(x)$ . What does  $f^{-1}(x)$  compute?

A)  $f^{-1}(x) = \frac{x}{25} - 146$ ; This computes the total cost if the contractor works  $x$  hours.

B)  $f^{-1}(x) = \frac{x}{25} - 3650$ ; This computes the number of hours worked if the total cost is  $x$  dollars.

C)  $f^{-1}(x) = \frac{x}{25} - 146$ ; This computes the number of hours worked if the total cost is  $x$  dollars.

D)  $f^{-1}(x) = \frac{x}{25} - 3650$ ; This computes the total cost if the contractor works  $x$  hours.

Answer: C

1) Give the coordinates of the points on the following graph.

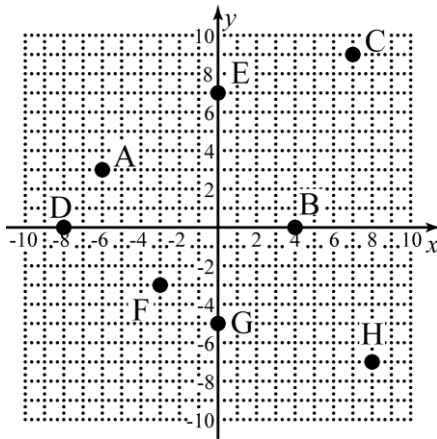

1) \_\_\_\_\_

2) List the transformations to the basic graph and graph the function.

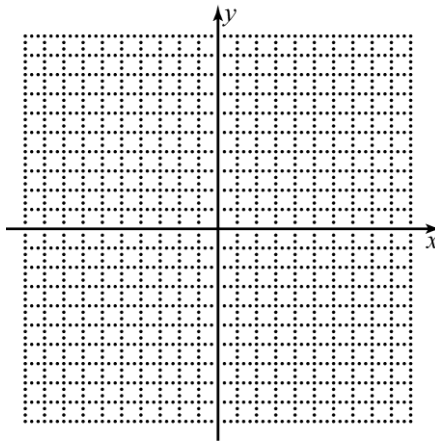

$$f(x) = 3(x + 7)^2 - 5$$

2) \_\_\_\_\_

3) Find the x- and y-intercepts of the following equation.

$$y = x^2 + 2x - 15$$

3) \_\_\_\_\_

4) Determine the slopes of the lines parallel and perpendicular to  $-3x + 2y = -5$ .

4) \_\_\_\_\_

5) Find the domain of the following function. Write your answer using interval notation.

$$f(x) = \frac{x-2}{\sqrt{10-2x}}$$

5) \_\_\_\_\_

6) Find the distance and midpoint between  $(-4, 3)$  and  $(10, -11)$ .

6) \_\_\_\_\_

7) Write the equation of the circle centered at  $(-3,4)$  with a radius of 8. 7) \_\_\_\_\_

8) Determine the equation of the circle in standard form described by  $x^2 - 4x + y^2 + 6y - 36 = 0$ . 8) \_\_\_\_\_

In exercises 9–10, find the equation of the following lines. Write your answer in slope-intercept form.

9) Passing through  $(5,-3)$  with slope  $-2$ . 9) \_\_\_\_\_

10) Passing through  $(-3,7)$  and  $(1,5)$ . 10) \_\_\_\_\_

11) Write the formula for the graph of  $f(x)$  below.

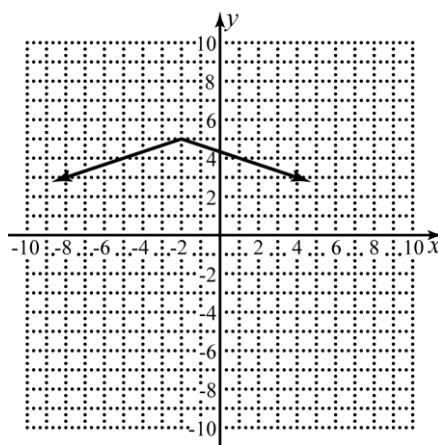

11) \_\_\_\_\_

12) Determine the a) domain and b) range of the function graphed below.

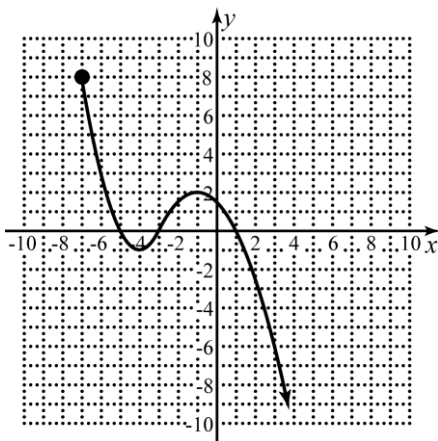

12) \_\_\_\_\_

- 13) Given the following graph determine: a) where is the graph increasing, b) where is the graph decreasing, c) where is the graph constant.

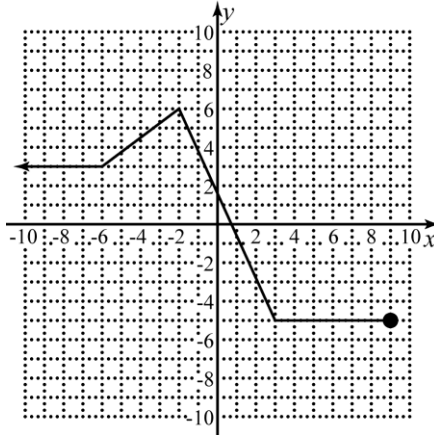

13) \_\_\_\_\_

- 14) Determine which symmetries the graph of the following equation possesses.

$$x^2 - y^2 = 4$$

14) \_\_\_\_\_

- 15) Graph the function given below and determine the given functional values.

$$f(x) = \begin{cases} (3-x)^2 - 4 & \text{if } x \leq 3; \\ 5 & \text{if } x > 3 \end{cases}; \quad f(-3), f(3), f(6)$$

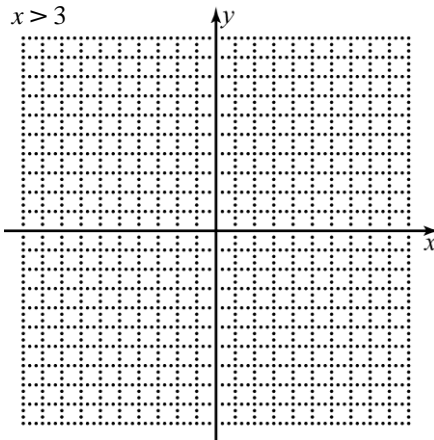

15) \_\_\_\_\_

- 16) Given  $f(x)$  and  $g(x)$ , find  $(f \circ g)(x)$  and determine its domain.

$$f(x) = 2x^2 - 5, \quad g(x) = \sqrt{x-5}$$

16) \_\_\_\_\_

- 17) Find  $f^{-1}(x)$  for  $f(x) = 3x - 7$

17) \_\_\_\_\_

18) Find  $\frac{f(x+h)-f(x)}{h}$  for  $f(x) = x^2 + 2x$  18) \_\_\_\_\_

19) A company that produced toy cars has a monthly a monthly cost of 1,500 dollars and a marginal cost of 3 dollars per toy car. The company makes 8 dollars per toy car in revenue.

a) Find the function,  $C(x)$ , that represents the cost of producing  $x$  toy cars.

b) Find the function,  $R(x)$ , that represents the revenue from selling  $x$  toy cars.

c) Find the function,  $P(x)$ , that represents the profit from selling  $x$  toy cars.

d) What would the profit be from selling 2500 toy cars? 19) \_\_\_\_\_

20) Find the linear regression equation for the following data.

|     |   |    |    |    |    |    |
|-----|---|----|----|----|----|----|
| $x$ | 2 | 8  | 16 | 18 | 24 | 26 |
| $y$ | 4 | 13 | 18 | 27 | 31 | 34 |

20) \_\_\_\_\_

- 1) Give the coordinates of the points on the following graph.

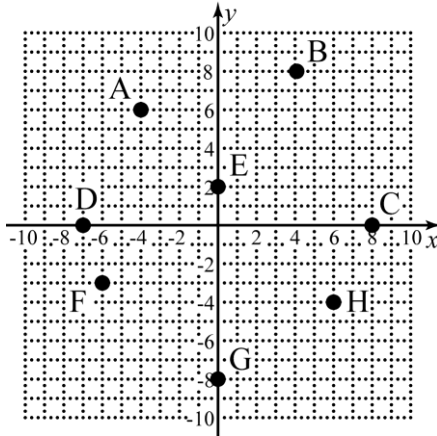

1) \_\_\_\_\_

- 2) List the transformations to the basic graph and graph the function.

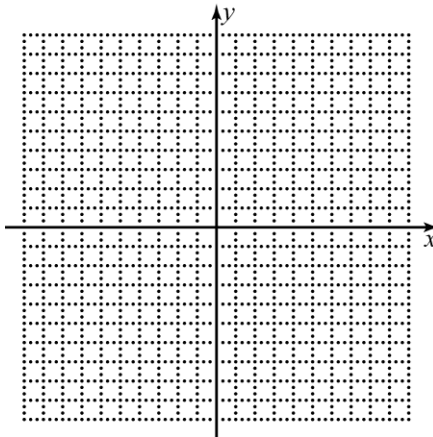

$$f(x) = 2(x + 8)^2 - 4$$

2) \_\_\_\_\_

- 3) Find the  $x$ - and  $y$ -intercepts of the following equation.

$$y = \sqrt{2x + 16}$$

3) \_\_\_\_\_

- 4) Determine the slopes of the lines parallel and perpendicular to  $2x + 3y = 7$ .

4) \_\_\_\_\_

- 5) Find the domain of the following function. Write your answer using interval notation.

$$f(x) = \frac{x+7}{\sqrt{3x-18}}$$

5) \_\_\_\_\_

- 6) Find the distance and midpoint between  $(5, -7)$  and  $(1, 1)$ .

6) \_\_\_\_\_

7) Write the equation of the circle centered at  $(5, -2)$  with a radius of 4. 7) \_\_\_\_\_

8) Determine the equation of the circle in standard form described by  $x^2 + 10x + y^2 - 8y + 5 = 0$ . 8) \_\_\_\_\_

In exercises 9–10, find the equation of the following lines. Write your answer in slope-intercept form.

9) Passing through  $(-4, 3)$  with slope 5. 9) \_\_\_\_\_

10) Passing through  $(4, 1)$  and  $(-1, -3)$ . 10) \_\_\_\_\_

11) Write the formula for the graph of  $f(x)$  below.

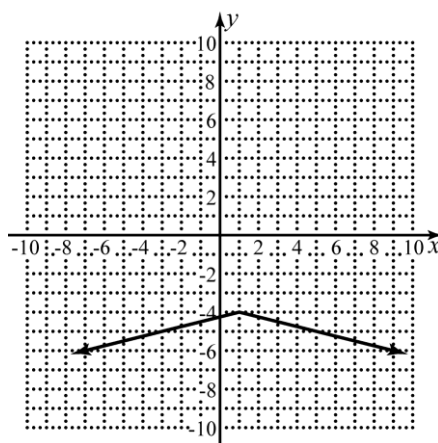

11) \_\_\_\_\_

12) Determine the a) domain and b) range of the function graphed below.

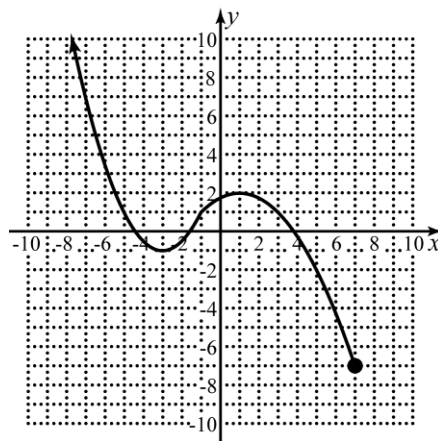

12) \_\_\_\_\_

- 13) Given the following graph determine: a) where is the graph increasing, b) where is the graph decreasing, c) where is the graph constant.

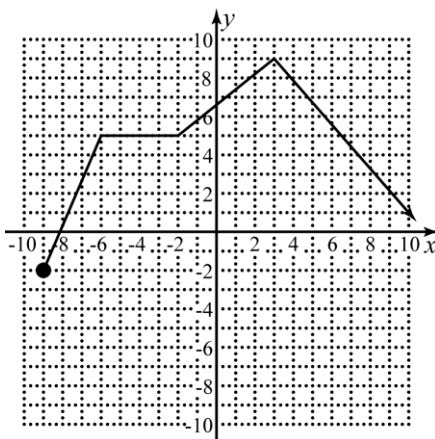

13) \_\_\_\_\_

- 14) Determine which symmetries the graph of the following equation possesses.

$$y = x^4 - x^2$$

14) \_\_\_\_\_

- 15) Graph the function given below and determine the given functional values.

$$f(x) = \begin{cases} 3-x & \text{if } x > -2 \\ -3 & \text{if } x \leq -2 \end{cases}; \quad f(-2), f(2), f(-1)$$

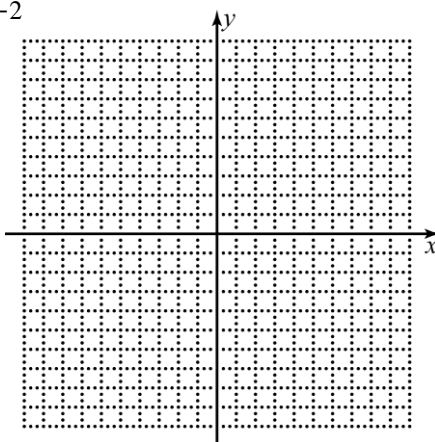

15) \_\_\_\_\_

- 16) Given  $f(x)$  and  $g(x)$ , find  $(f \circ g)(x)$  and determine its domain.

$$f(x) = \frac{x^2 + 1}{x^2 + 7}, \quad g(x) = \sqrt{x + 7}$$

16) \_\_\_\_\_

- 17) Find  $f^{-1}(x)$  for  $f(x) = \frac{5}{x+3}$

17) \_\_\_\_\_



18) Find  $\frac{f(x+h)-f(x)}{h}$  for  $f(x) = 3x - 2x^2$  18) \_\_\_\_\_

19) A company that produced toy cars has a monthly a monthly cost of 2,000 dollars and a marginal cost of 8 dollars per toy car. The company makes 15 dollars per toy car in revenue.

a) Find the function,  $C(x)$ , that represents the cost of producing  $x$  toy cars.

b) Find the function,  $R(x)$ , that represents the revenue from selling  $x$  toy cars.

c) Find the function,  $P(x)$ , that represents the profit from selling  $x$  toy cars.

d) What would the profit be from selling 3250 toy cars? 19) \_\_\_\_\_

20) Find the linear regression equation for the following data.

|     |   |   |    |    |    |    |
|-----|---|---|----|----|----|----|
| $x$ | 3 | 5 | 13 | 17 | 26 | 37 |
| $y$ | 9 | 7 | 22 | 18 | 30 | 45 |

20) \_\_\_\_\_

1) Give the coordinates of the points on the following graph.

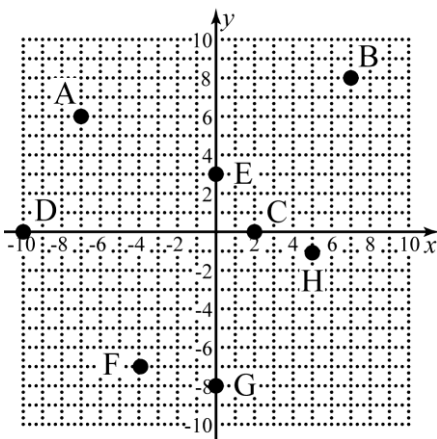

1) \_\_\_\_\_

2) List the transformations to the basic graph and graph the function.

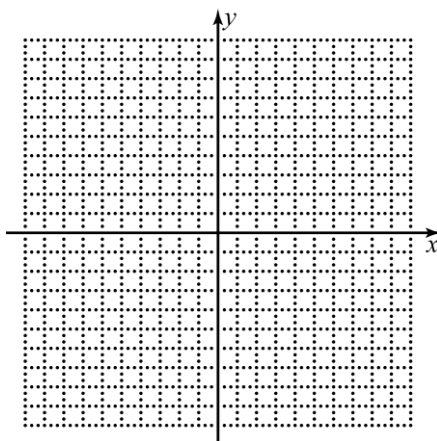

$$f(x) = 2(x - 7)^2 + 3$$

2) \_\_\_\_\_

3) Find the  $x$ - and  $y$ -intercepts of the following equation.

$$y = \sqrt[3]{2x + 8}$$

3) \_\_\_\_\_

4) Determine the slopes of the lines parallel and perpendicular to  $5x - 3y = 4$

4) \_\_\_\_\_

5) Find the domain of the following function. Write your answer using interval notation.

$$f(x) = \frac{x - 5}{\sqrt{2x + 14}}$$

5) \_\_\_\_\_

6) Find the distance and midpoint between  $(8, 5)$  and  $(4, -9)$ .

6) \_\_\_\_\_

7) Write the equation of the circle centered at  $(-3,5)$  with a radius of 6. 7) \_\_\_\_\_

8) Determine the equation of the circle in standard form described by  $x^2 - 6x + y^2 + 10y + 9 = 0$ . 8) \_\_\_\_\_

In exercises 9–10, find the equation of the following lines. Write your answer in slope-intercept form.

9) Passing through  $(1,-2)$  with slope  $-3$ . 9) \_\_\_\_\_

10) Passing through  $(-2,1)$  and  $(4,-4)$ . 10) \_\_\_\_\_

11) Write the formula for the graph of  $f(x)$  below.

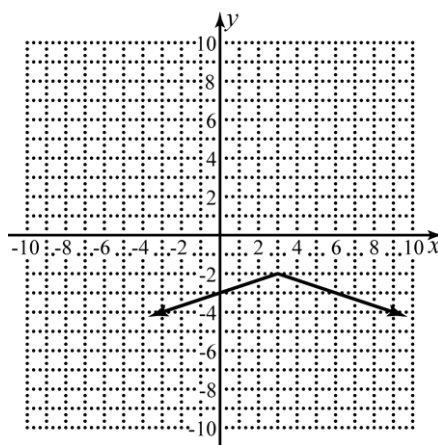

11) \_\_\_\_\_

12) Determine the a) domain and b) range of the function graphed below.

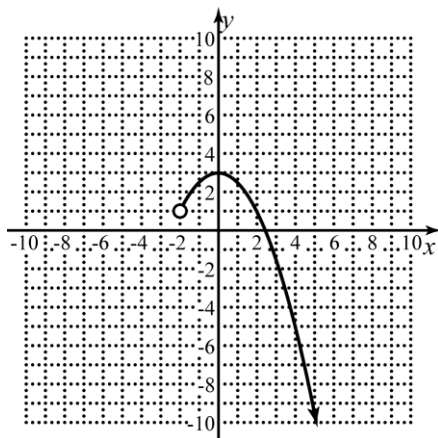

12) \_\_\_\_\_

- 13) Given the following graph determine: a) where is the graph increasing, b) where is the graph decreasing, c) where is the graph constant.

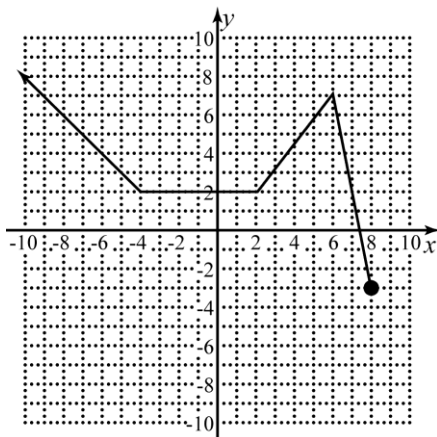

13) \_\_\_\_\_

- 14) Determine which symmetries the graph of the following equation possesses.

$$x^3y^2 + x = 4$$

14) \_\_\_\_\_

- 15) Graph the function given below and determine the given functional values.

$$f(x) = \begin{cases} 3 & \text{if } x > 4 \\ 3 - 2x & \text{if } x \leq 4 \end{cases}; f(-4), f(4), f(8)$$

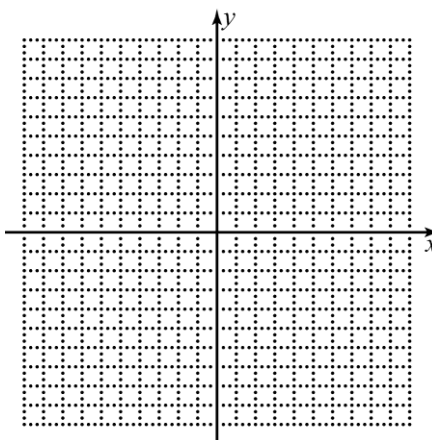

15) \_\_\_\_\_

- 16) Given  $f(x)$  and  $g(x)$ , find  $(f \circ g)(x)$  and determine its domain.

$$f(x) = 3x^2 + 2, g(x) = \sqrt{7 - x}$$

16) \_\_\_\_\_

- 17) Find  $f^{-1}(x)$  for  $f(x) = x^3 + 8$

17) \_\_\_\_\_

18) Find  $\frac{f(x+h)-f(x)}{h}$  for  $f(x) = 4x^2 - 7x$ . 18) \_\_\_\_\_

19) A company that produced toy cars has a monthly a monthly cost of 1,800 dollars and a marginal cost of 5 dollars per toy car. The company makes 13 dollars per toy car in revenue.

a) Find the function,  $C(x)$ , that represents the cost of producing  $x$  toy cars.

b) Find the function,  $R(x)$ , that represents the revenue from selling  $x$  toy cars.

c) Find the function,  $P(x)$ , that represents the profit from selling  $x$  toy cars.

d) What would the profit be from selling 1500 toy cars? 19) \_\_\_\_\_

20) Find the linear regression equation for the following data.

|     |    |    |    |    |    |    |
|-----|----|----|----|----|----|----|
| $x$ | 8  | 10 | 15 | 16 | 22 | 35 |
| $y$ | 11 | 14 | 19 | 19 | 25 | 41 |

20) \_\_\_\_\_

- 1) Give the coordinates of the points on the following graph.

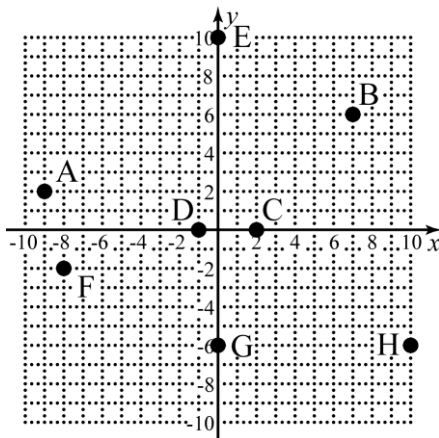

1) \_\_\_\_\_

- 2) List the transformations to the basic graph and graph the function.

$$f(x) = 3(x + 1)^2 - 3$$

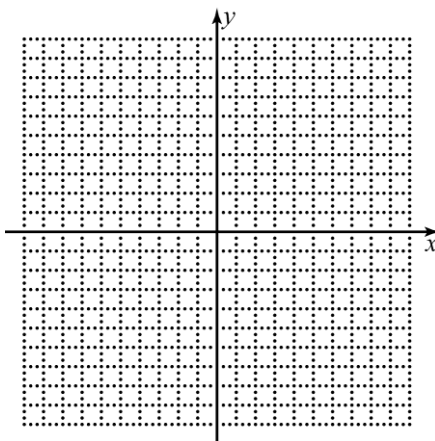

2) \_\_\_\_\_

- 3) Find the  $x$ - and  $y$ -intercepts of the following equation.

$$y = x^2 - 25$$

3) \_\_\_\_\_

- 4) Determine the slopes of the lines parallel and perpendicular to  $-4x - 3y = 5$ .

4) \_\_\_\_\_

- 5) Find the domain of the following function. Write your answer using interval notation.

$$f(x) = \frac{x + 3}{\sqrt{16 - 2x}}$$

5) \_\_\_\_\_

- 6) Find the distance and midpoint between  $(-6, 1)$  and  $(4, -9)$ .

6) \_\_\_\_\_

7) Write the equation of the circle centered at  $(-5, 2)$  with a radius of 5. 7) \_\_\_\_\_

8) Determine the equation of the circle in standard form described by  $x^2 - 14x + y^2 + 8y + 56 = 0$ . 8) \_\_\_\_\_

In exercises 9–10, find the equation of the following lines. Write your answer in slope-intercept form.

9) Passing through  $(-2, 3)$  with slope 4 9) \_\_\_\_\_

10) Passing through  $(-1, -2)$  and  $(4, 2)$  10) \_\_\_\_\_

11) Write the formula for the graph of  $f(x)$  below.

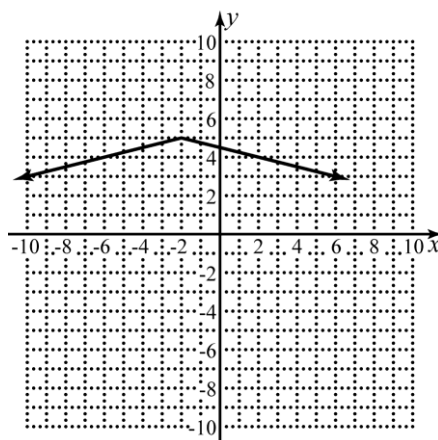

11) \_\_\_\_\_

12) Determine the a) domain and b) range of the function graphed below.

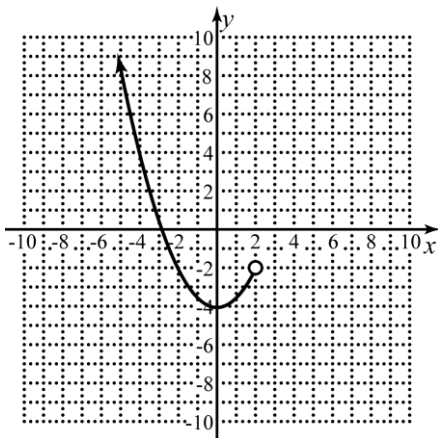

12) \_\_\_\_\_

- 13) Given the following graph determine: a) where is the graph increasing, b) where is the graph decreasing, c) where is the graph constant.

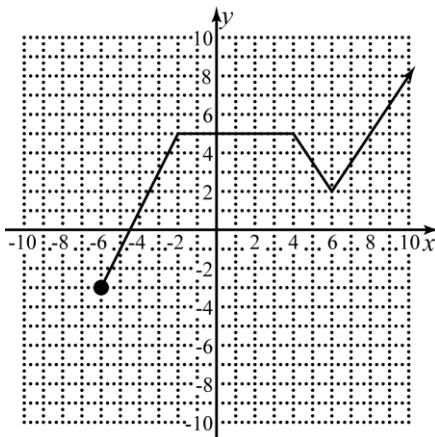

13) \_\_\_\_\_

- 14) Determine which symmetries the graph of the following equation possesses.

$$y = 3x^5 - 4x^3$$

14) \_\_\_\_\_

- 15) Graph the function given below and determine the given functional values.

$$f(x) = \begin{cases} -x^2 + 9 & \text{if } x < 1; \\ -5 & \text{if } x \geq 1 \end{cases}; \quad f(-1), f(1), f(5)$$

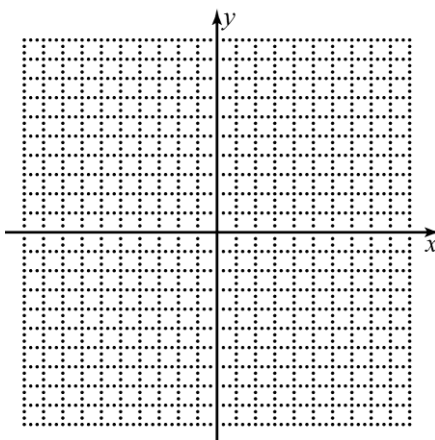

15) \_\_\_\_\_

- 16) Given  $f(x)$  and  $g(x)$ , find  $(f \circ g)(x)$  and determine its domain.

$$f(x) = \frac{x^2}{x^2 + 3}, \quad g(x) = \sqrt{x - 2}$$

16) \_\_\_\_\_

- 17) Find  $f^{-1}(x)$  for  $f(x) = 8 - 3x$

17) \_\_\_\_\_



18) Find  $\frac{f(x+h)-f(x)}{h}$  for  $f(x) = x^3 + x$

18) \_\_\_\_\_

19) A company that produced toy cars has a monthly a monthly cost of 2,400 dollars and a marginal cost of 10 dollars per toy car. The company makes 25 dollars per toy car in revenue.

a) Find the function,  $C(x)$ , that represents the cost of producing  $x$  toy cars.b) Find the function,  $R(x)$ , that represents the revenue from selling  $x$  toy cars.c) Find the function,  $P(x)$ , that represents the profit from selling  $x$  toy cars.

d) What would the profit be from selling 600 toy cars?

19) \_\_\_\_\_

20) Find the linear regression equation for the following data.

|     |    |    |    |    |    |    |
|-----|----|----|----|----|----|----|
| $x$ | 10 | 18 | 22 | 29 | 30 | 39 |
| $y$ | 19 | 22 | 28 | 30 | 38 | 45 |

20) \_\_\_\_\_

In exercises 1–2, use the points  $(-2, 1)$  and  $(6, -7)$ .

1) Find the distance between the points. 1) \_\_\_\_\_

- a)  $4\sqrt{5}$       b) 4      c)  $2\sqrt{13}$       d)  $8\sqrt{2}$

2) Find the midpoint between the points. 2) \_\_\_\_\_

- a)  $(4, -4)$       b)  $(2, -3)$       c)  $(-4, 4)$       d)  $(-2, 3)$

In exercises 3–6, refer to the graph to the right.

3) What are the coordinates of point A? 3) \_\_\_\_\_

- a)  $(-3, 9)$       b)  $(3, -9)$   
c)  $(9, -3)$       d)  $(-9, 3)$

4) What are the coordinates of point B? 4) \_\_\_\_\_

- a)  $(-5, 9)$       b)  $(-5, -9)$   
c)  $(-9, 5)$       d)  $(5, -9)$

5) What are the coordinates of point C? 5) \_\_\_\_\_

- a)  $(-4, 0)$       b)  $(4, 0)$   
c)  $(0, 4)$       d)  $(0, -4)$

6) What are the coordinates of point D? 6) \_\_\_\_\_

- a)  $(-4, 0)$       b)  $(4, 0)$   
c)  $(0, 4)$       d)  $(0, -4)$

7) Find the coordinates of the intercepts of  $y = x^2 - x - 30$  7) \_\_\_\_\_

- a)  $(30, 0), (0, 5), (0, -6)$       b)  $(30, 0), (0, -5), (0, 6)$   
c)  $(0, -30), (5, 0), (-6, 0)$       d)  $(0, -30), (-5, 0), (6, 0)$

8) Which of the following is not a transformation of the basic function in 8) \_\_\_\_\_

$$g(x) = \frac{1}{2}(x+3)^2 - 1$$

- a) vertical shift of 1 down      b) vertical reflection  
c) vertical stretch of  $\frac{1}{2}$       d) horizontal shift of 3 to the left

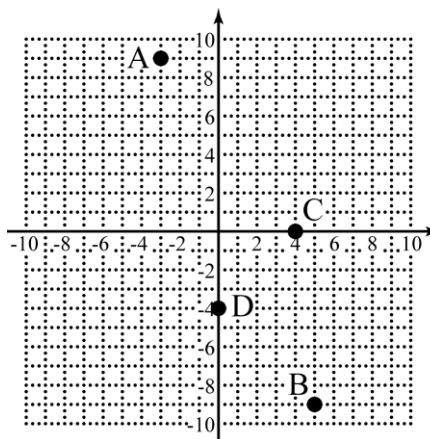



9) Write the formula for the function graphed to the right

9) \_\_\_\_\_

- a)  $f(x) = -4|x + 2| - 2$
- b)  $f(x) = -4|x - 2| + 2$
- c)  $f(x) = -\frac{1}{4}|x + 2| - 2$
- d)  $f(x) = -\frac{1}{4}|x - 2| + 2$

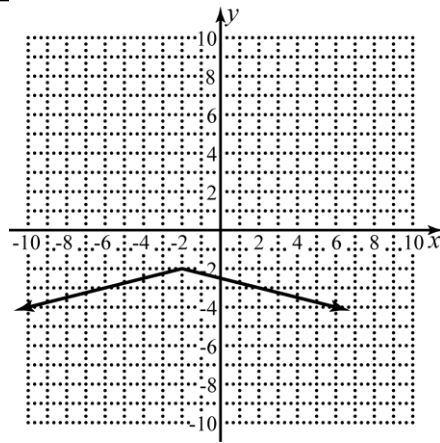

10) Graph  $f(x) = 3(x - 3)^2 + 1$

10) \_\_\_\_\_

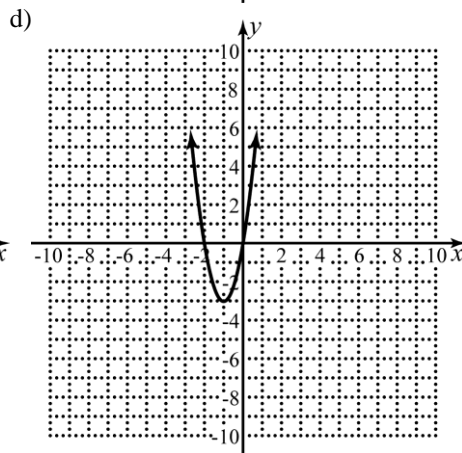
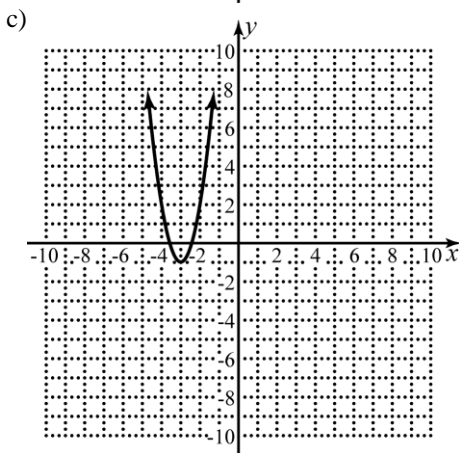
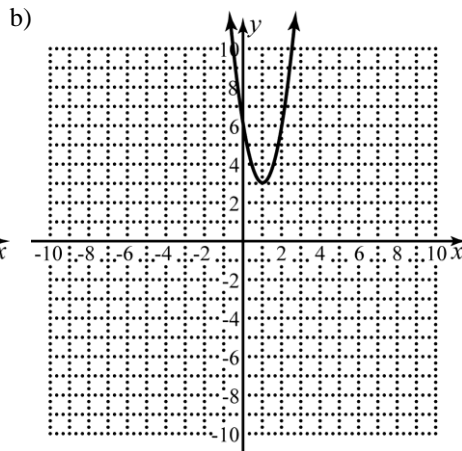
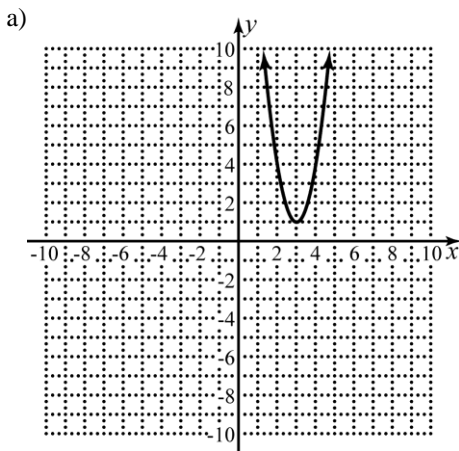

11) Determine the slopes of the lines parallel and perpendicular to  $2x + 5y = 13$ . 11) \_\_\_\_\_

- a) Parallel:  $-\frac{2}{5}$ ; perpendicular:  $\frac{2}{5}$       b) Parallel:  $-\frac{2}{5}$ ; perpendicular:  $\frac{5}{2}$   
 c) Parallel:  $\frac{2}{5}$ ; perpendicular:  $-\frac{2}{5}$       d) Parallel:  $\frac{2}{5}$ ; perpendicular:  $-\frac{5}{2}$

12) Find the domain of  $f(x) = \frac{x+3}{\sqrt{35-5x}}$ . Write your answer using interval notation. 12) \_\_\_\_\_

- a)  $(7, \infty)$       b)  $(-7, \infty)$       c)  $(-\infty, 7)$       d)  $(-\infty, -7)$

13) Determine which symmetries the graph of the  $xy + x^3 = y$  possesses. 13) \_\_\_\_\_

- a) x-axis      b) y-axis      c) origin      d) none

In exercises 14–15, refer to the graph to the right.

14) Determine the domain of the function. 14) \_\_\_\_\_

- a)  $(-3, \infty)$       b)  $[-3, \infty)$   
 c)  $(-\infty, 8]$       d)  $(-\infty, 8]$

15) Determine the range of the function. 15) \_\_\_\_\_

- a)  $(-3, \infty)$       b)  $[-3, \infty)$   
 c)  $(-\infty, 8]$       d)  $(-\infty, 8]$

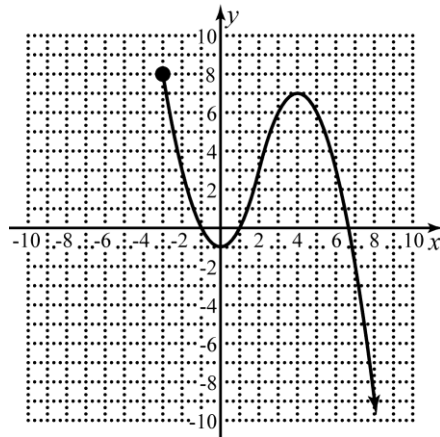

In exercises 16–17, find the equation of the following lines. Write your answer in slope-intercept form.

16) Passing through  $(-1, 4)$  with slope 3. 16) \_\_\_\_\_

- a)  $y = 3x + 7$       b)  $y = 3x + 4$       c)  $y = 3x - 1$       d)  $y = 3x - 13$

17) Passing through  $(-4, 3)$  and  $(2, 4)$ . 17) \_\_\_\_\_

- a)  $y = 6x + 27$       b)  $y = -6x - 21$       c)  $y = \frac{1}{6}x + \frac{11}{3}$       d)  $y = -\frac{1}{6}x + \frac{7}{3}$

18) Write the equation of the circle centered at  $(4, -5)$  with a radius of 9. 18) \_\_\_\_\_

- a)  $(x+4)^2 + (y-5)^2 = 81$       b)  $(x-4)^2 + (y+5)^2 = 81$   
 c)  $(x+4)^2 + (y-5)^2 = 9$       d)  $(x-4)^2 + (y+5)^2 = 9$



19) Determine the equation of the circle described by  $x^2 - 8x + y^2 + 10y - 59 = 0$ . 19) \_\_\_\_\_

- a)  $(x-8)^2 + (y+10)^2 = 59$       b)  $(x-4)^2 + (y+5)^2 = 41$   
 c)  $(x-4)^2 + (y+5)^2 = 100$       d)  $(x-4)^2 + (y+5)^2 = 59$

In exercises 20–22, refer to the graph to the right.

20) When is the graph to the right increasing? 20) \_\_\_\_\_

- a)  $(-2, 2)$       b)  $(6, 9)$   
 c)  $(-\infty, -2) \cup (2, 6)$       d) Never

21) When is the graph to the right decreasing? 21) \_\_\_\_\_

- a)  $(-2, 2)$       b)  $(6, 9)$   
 c)  $(-\infty, -2) \cup (2, 6)$       d) Never

22) When is the graph to the right constant? 22) \_\_\_\_\_

- a)  $(-2, 2)$       b)  $(6, 9)$   
 c)  $(-\infty, -2) \cup (2, 6)$       d) Never

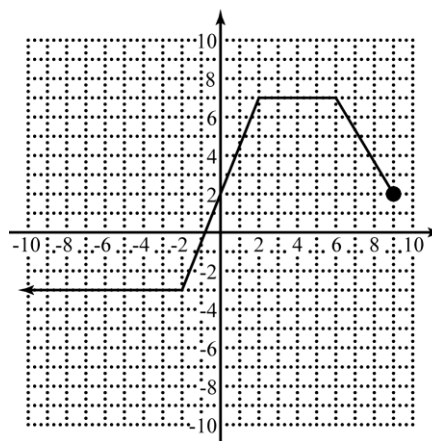
23) Given  $f(x) = \sqrt[3]{x-27}$ , find  $f^{-1}(x)$ . 23) \_\_\_\_\_

- a)  $f^{-1}(x) = \sqrt[3]{x+27}$       b)  $f^{-1}(x) = \frac{1}{\sqrt[3]{x-27}}$   
 c)  $f^{-1}(x) = x^3 + 27$       d)  $f^{-1}(x) = -\sqrt[3]{x-27}$

24) Find  $\frac{f(x+h)-f(x)}{h}$  for  $f(x) = x^3 - x$ . 24) \_\_\_\_\_

- a)  $h^2 - 1$       b)  $h^2 + 3hx + 3x^2 - 1$   
 c)  $h^2 + 3hx + 3x^2 + 1$       d)  $3x^2 - 1$

25) Given  $f(x)$  and  $g(x)$ , find  $(f \circ g)(x)$  and determine its domain. 25) \_\_\_\_\_

$$f(x) = 7x^2 + 4, g(x) = \sqrt{8-x}$$

$$\sqrt{\quad}$$

- a)  $\sqrt{4-7x^2}; (-\infty, \infty)$       b)  $4-7x^2; (-\infty, 8]$   
 c)  $60-7x; (-\infty, 8]$       d)  $60-7x; [8, \infty)$





In exercises 26–29, use  $f(x) = \begin{cases} |2-x|-5 & \text{if } x \leq 4 \\ 3 & \text{if } x > 4 \end{cases}$

26) Graph  $f(x)$ .

26) \_\_\_\_\_

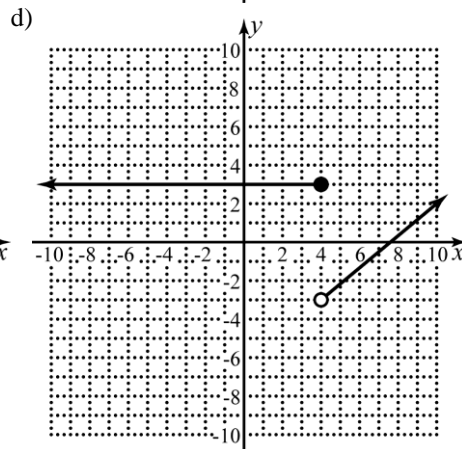
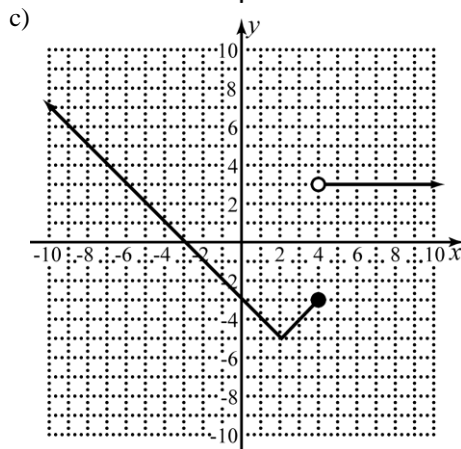
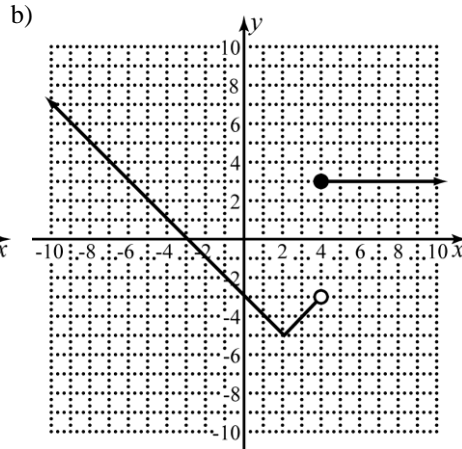
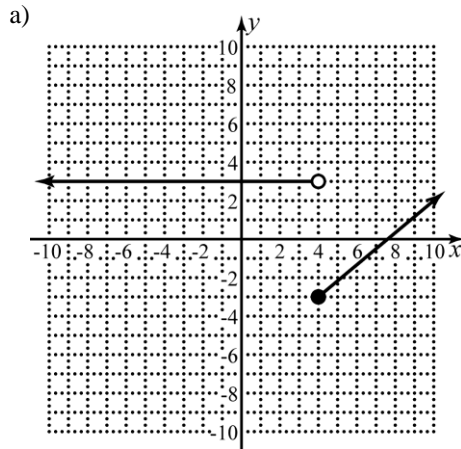

27) Determine the value of  $f(4)$ .

27) \_\_\_\_\_

a) -3

b) 1

c) 7

d) 3

28) Determine the value of  $f(-4)$ .

28) \_\_\_\_\_

a) -1

b) -3

c) 3

d) 1

29) Determine the value of  $f(6)$ .

29) \_\_\_\_\_

a) 1

b) 3

c) -3

d) -1



A company that produced toy cars has a monthly a monthly cost of 2,300 dollars and a marginal cost of 4 dollars per toy car. The company makes 11 dollars per toy car in revenue. With this information, answer exercises 30–33.

30) Find the function,  $C(x)$ , that represents the total cost of producing  $x$  toy cars. 30) \_\_\_\_\_

a)  $C(x) = 4x$

b)  $C(x) = 11x + 2300$

c)  $C(x) = 4x + 2300$

d)  $C(x) = 2300x + 4$

31) Find the function,  $R(x)$ , that represents the revenue from selling  $x$  toy cars. 31) \_\_\_\_\_

a)  $R(x) = 11x - 2300$

b)  $R(x) = 11x$

c)  $R(x) = 4x$

d)  $R(x) = 7x$

32) Find the function,  $P(x)$ , that represents the profit from selling  $x$  toy cars. 32) \_\_\_\_\_

a)  $P(x) = 11x - 2300$

b)  $P(x) = 7x - 2300$

c)  $P(x) = 7x$

d)  $P(x) = 2300 - 7x$

33) What would the profit be from selling 1150 toy cars? 33) \_\_\_\_\_

a) \$8,050

b) -\$5,750

c) \$10,350

d) \$5,750

34) Find the linear regression equation for the following data. 34) \_\_\_\_\_

|     |    |    |    |    |    |    |
|-----|----|----|----|----|----|----|
| $x$ | 19 | 23 | 29 | 30 | 37 | 38 |
| $y$ | 24 | 32 | 30 | 38 | 44 | 41 |

a)  $y = 0.92x - 2.59$

b)  $y = 8.00x + 0.91$

c)  $y = -2.59x + 0.92$

d)  $y = 0.91x + 8.00$

---



In exercises 1–2, use the points  $(5, -4)$  and  $(-7, 10)$ .

- 1) Find the distance between the points. 1) \_\_\_\_\_  
 a)  $2\sqrt{85}$       b)  $2\sqrt{13}$       c)  $\sqrt{26}$       d)  $2\sqrt{10}$
- 2) Find the midpoint between the points. 2) \_\_\_\_\_  
 a)  $(-1, 3)$       b)  $(6, -7)$       c)  $(-7, 6)$       d)  $(1, -3)$

In exercises 3–6, refer to the graph to the right.

- 3) What are the coordinates of point A? 3) \_\_\_\_\_  
 a)  $(6, -7)$       b)  $(-7, 6)$   
 c)  $(-7, -6)$       d)  $(-6, 7)$
- 4) What are the coordinates of point B? 4) \_\_\_\_\_  
 a)  $(3, 0)$       b)  $(-3, 0)$   
 c)  $(0, 3)$       d)  $(0, -3)$
- 5) What are the coordinates of point C? 5) \_\_\_\_\_  
 a)  $(2, -2)$       b)  $(-2, 2)$   
 c)  $(-2, -2)$       d)  $(2, 2)$
- 6) What are the coordinates of point D? 6) \_\_\_\_\_  
 a)  $(-4, 0)$       b)  $(4, 0)$   
 c)  $((0, 4)$       d)  $(0, -4)$

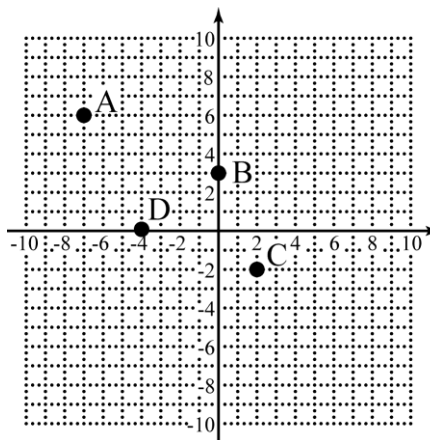

- 7) Find the coordinates of the intercepts of  $y = \sqrt[3]{3x - 27}$  7) \_\_\_\_\_  
 a)  $(3, 0), (0, -9)$       b)  $(-3, 0), (0, 9)$   
 c)  $(0, -3), (-9, 0)$       d)  $(0, -3), (9, 0)$
- 8) Which of the following is not a transformation of the basic function in  $g(x) = -3(x - 2)^2 + 7$  8) \_\_\_\_\_  
 a) vertical stretch of  $\frac{1}{3}$       b) vertical reflection  
 c) horizontal shift of 2 to the right      d) vertical shift of 7 up



9) Write the formula for the function graphed to the right

9) \_\_\_\_\_

- a)  $f(x) = -\frac{1}{3}|x + 3| + 3$
- b)  $f(x) = -\frac{1}{3}|x - 3| + 3$
- c)  $f(x) = -3|x + 3| + 3$
- d)  $f(x) = -3|x - 3| + 3$

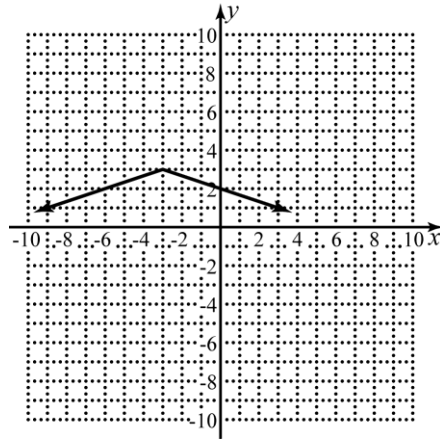

10) Graph  $f(x) = 2(x + 2)^2 - 3$

10) \_\_\_\_\_

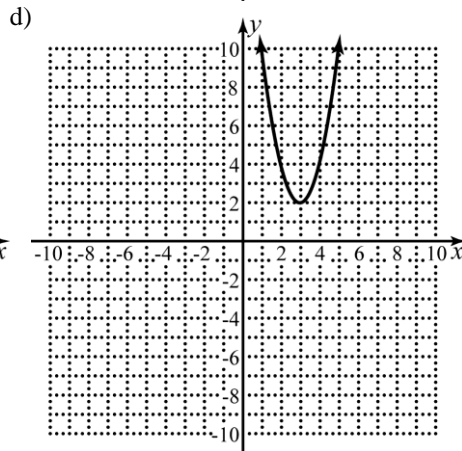
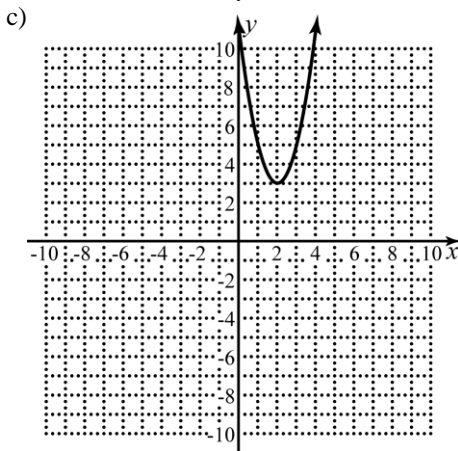
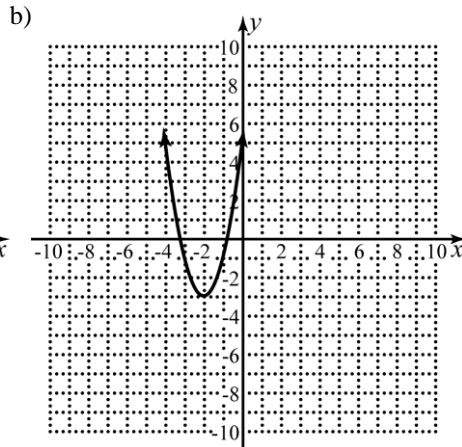
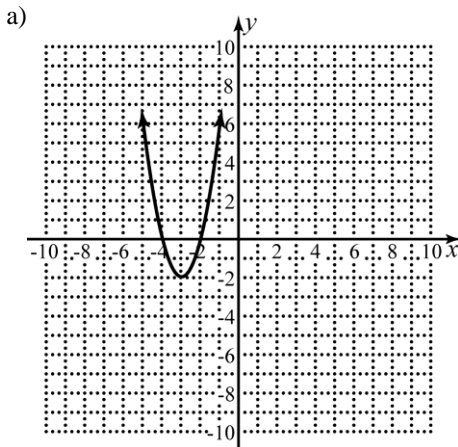

---

 11) Determine the slopes of the lines parallel and perpendicular to  $-4x + 3y = 11$ . 11) \_\_\_\_\_

- a) Parallel:  $\frac{4}{3}$ ; perpendicular:  $-\frac{4}{3}$       b) Parallel:  $-\frac{4}{3}$ ; perpendicular:  $\frac{4}{3}$   
 c) Parallel:  $\frac{4}{3}$ ; perpendicular:  $-\frac{3}{4}$       d) Parallel:  $-\frac{4}{3}$ ; perpendicular:  $\frac{3}{4}$

 12) Find the domain of  $f(x) = \frac{x-5}{\sqrt{24-4x}}$ . Write your answer using interval notation. 12) \_\_\_\_\_

- a)  $(-\infty, 6)$       b)  $(-\infty, -6)$       c)  $(-6, \infty)$       d)  $(6, \infty)$

 13) Determine which symmetries the graph of the  $x^2y^2 - x^4 = y$  possesses. 13) \_\_\_\_\_

- a) x-axis      b) y-axis      c) origin      d) none

In exercises 14–15, refer to the graph to the right.

14) Determine the domain of the function. 14) \_\_\_\_\_

- a)  $(-\infty, 6]$       b)  $(-\infty, 6)$   
 c)  $[-8, \infty)$       d)  $(-8, \infty)$

15) Determine the range of the function.

- a)  $(-\infty, 6]$       b)  $(-\infty, 6)$   
 c)  $[-8, \infty)$       d)  $(-8, \infty)$

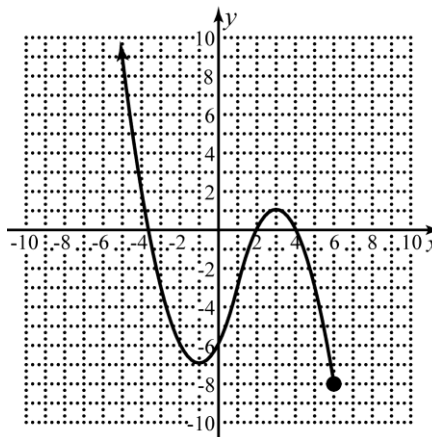

15) \_\_\_\_\_

In exercises 16–17, find the equation of the following lines. Write your answer in slope-intercept form.

 16) Passing through  $(-5, 4)$  with slope  $-3$ . 16) \_\_\_\_\_

- a)  $y = -3x + 17$       b)  $y = -3x - 1$       c)  $y = -3x + 4$       d)  $y = -3x - 11$

 17) Passing through  $(-3, -2)$  and  $(2, 5)$ . 17) \_\_\_\_\_

- a)  $y = -\frac{7}{5}x + \frac{39}{5}$       b)  $y = \frac{7}{5}x + \frac{11}{5}$       c)  $y = -\frac{5}{7}x + \frac{45}{7}$       d)  $y = \frac{5}{7}x - \frac{25}{7}$

 18) Write the equation of the circle centered at  $(-4, 3)$  with a radius of 7. 18) \_\_\_\_\_

- 
- a)  $(x-4)^2 + (y+3)^2 = 7$       b)  $(x-4)^2 + (y+3)^2 = 49$   
 c)  $(x+4)^2 + (y-3)^2 = 7$       d)  $(x+4)^2 + (y-3)^2 = 49$





19) Determine the equation of the circle described by  $x^2 + 6x + y^2 - 8y - 56 = 0$ . 19) \_\_\_\_\_

- a)  $(x + 6)^2 + (y - 8)^2 = 56$       b)  $(x + 3)^2 + (y - 4)^2 = 81$   
 c)  $(x + 3)^2 + (y - 4)^2 = 25$       d)  $(x + 3)^2 + (y - 4)^2 = 56$

In exercises 20–22, refer to the graph to the right.

20) When is the graph to the right increasing? 20) \_\_\_\_\_

- a)  $(-\infty, -2) \cup [5, 9)$       b)  $(2, 5)$   
 c)  $(-2, 2)$       d) Never

21) When is the graph to the right decreasing? 21) \_\_\_\_\_

- a)  $(-\infty, -2) \cup [5, 9)$       b)  $(2, 5)$   
 c)  $(-2, 2)$       d) Never

22) When is the graph to the right constant? 22) \_\_\_\_\_

- a)  $(-\infty, -2) \cup [5, 9)$       b)  $(2, 5)$   
 c)  $(-2, 2)$       d) Never

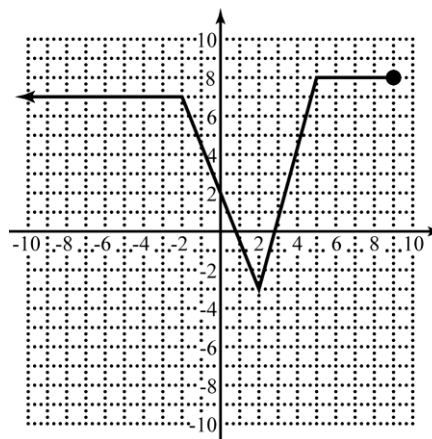

23) Given  $f(x) = \frac{4}{x-5}$ , find  $f^{-1}(x)$ . 23) \_\_\_\_\_

- a)  $f^{-1}(x) = \frac{5x+4}{x}$       b)  $f^{-1}(x) = \frac{x-5}{4}$   
 c)  $f^{-1}(x) = -\frac{4}{x-5}$       d)  $f^{-1}(x) = \frac{4}{x+5}$

24) Find  $\frac{f(x+h)-f(x)}{h}$  for  $f(x) = 2x^2 - 3x$ . 24) \_\_\_\_\_

- a)  $2h + 3$       b)  $4x - 1$       c)  $2h + 4x - 3$       d)  $2h + 4x + 3$

25) Given  $f(x)$  and  $g(x)$ , find  $(f \circ g)(x)$  and determine its domain. 25) \_\_\_\_\_

$$f(x) = \frac{x^2 - 3}{x^2 + 2}, g(x) = x + 3$$

- a)  $\sqrt{\frac{4x^2 + 3}{x^2 + 2}}; (-\infty, \infty)$       b)  $\sqrt{\frac{4x^2 + 3}{x^2 + 2}}; [-3, \infty)$

- c)  $\frac{x}{x+5}; (-\infty, -3]$       d)  $\frac{x}{x+5}; [-3, \infty)$



In exercises 26–29, use  $f(x) = \begin{cases} -3 & \text{if } x \geq 3 \\ |1-x|+2 & \text{if } x < 3 \end{cases}$

26) Graph  $f(x)$ .

26) \_\_\_\_\_

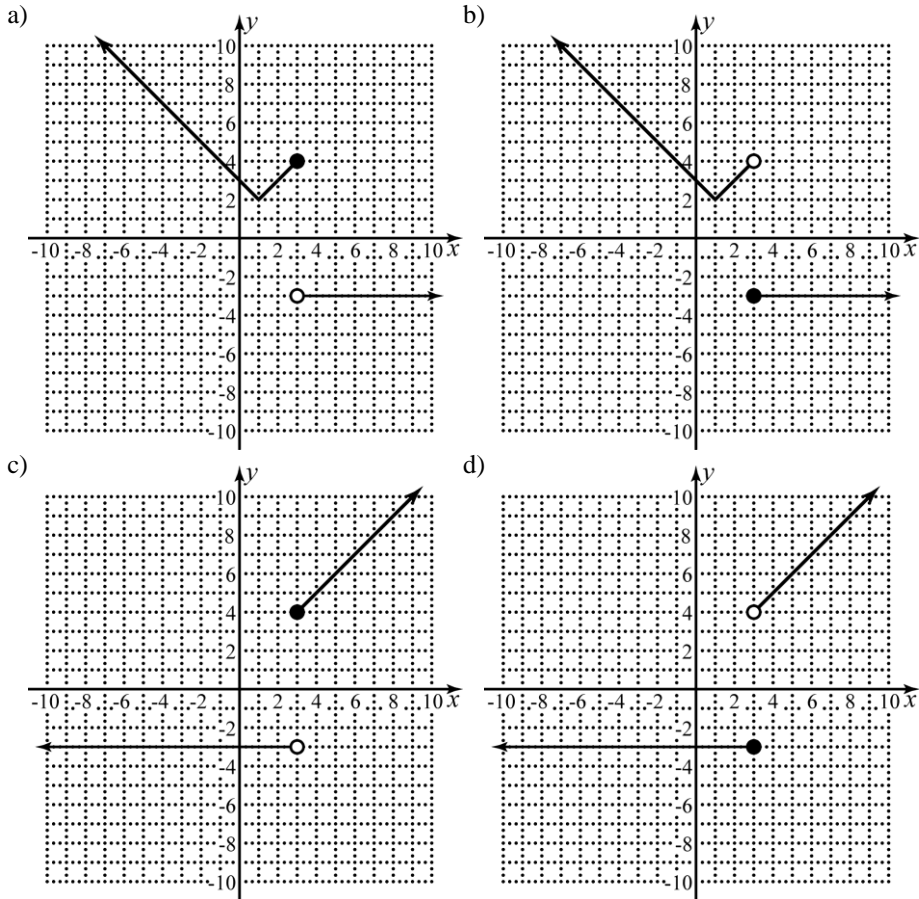

27) Determine the value of  $f(3)$ .

27) \_\_\_\_\_

- a) -3                      b) 6                      c) 2                      d) 18

28) Determine the value of  $f(-3)$ .

28) \_\_\_\_\_

- a) -3                      b) 6                      c) 4                      d) 0

29) Determine the value of  $f(0)$ .

29) \_\_\_\_\_

- a) 3                      b) 0                      c) 5                      d) -3

A company that produced toy cars has a monthly a monthly cost of 3,300 dollars and a marginal cost of 14 dollars per toy car. The company makes 32 dollars per toy car in revenue. With this information, answer exercises 30–33.

30) Find the function,  $C(x)$ , that represents the total cost of producing  $x$  toy cars. 30) \_\_\_\_\_

a)  $C(x) = 14x$

b)  $C(x) = 32x + 3300$

c)  $C(x) = 3300x + 14$

d)  $C(x) = 14x + 3300$

31) Find the function,  $R(x)$ , that represents the revenue from selling  $x$  toy cars. 31) \_\_\_\_\_

a)  $R(x) = 32x - 3300$

b)  $R(x) = 18x$

c)  $R(x) = 32x$

d)  $R(x) = 14x$

32) Find the function,  $P(x)$ , that represents the profit from selling  $x$  toy cars. 32) \_\_\_\_\_

a)  $P(x) = 32x - 3300$

b)  $P(x) = 3300 - 18x$

c)  $P(x) = 18x - 3300$

d)  $P(x) = 18x$

33) What would the profit be from selling 750 toy cars? 33) \_\_\_\_\_

a) \$10,200

b) \$20,700

c) \$13,500

d) -\$10,200

34) Find the linear regression equation for the following data. 34) \_\_\_\_\_

|     |    |    |    |    |    |    |
|-----|----|----|----|----|----|----|
| $x$ | 10 | 14 | 16 | 17 | 25 | 35 |
| $y$ | 16 | 23 | 22 | 20 | 32 | 39 |

a)  $y = 0.92x + 7.48$

b)  $y = -6.65x + 1.03$

c)  $y = 7.48x + 0.92$

d)  $y = 1.03x - 6.65$

---

