

**Test Bank for Precalculus Essentials 5th Edition Blitzer 0134578155  
9780134578156**

**Full link download:**

**Test Bank:**

<https://testbankpack.com/p/test-bank-for-prec calculus-essentials-5th-edition-blitzer-0134578155-9780134578156/>

**Solution Manual:** <https://testbankpack.com/p/solution-manual-for-prec calculus-essentials-5th-edition-blitzer-0134578155-9780134578156/>

## Ch. 2 Polynomial and Rational Functions

### 2.1 Complex Numbers

#### 1 Add and Subtract Complex Numbers

**MULTIPLE CHOICE.** Choose the one alternative that best completes the statement or answers the question.

**Add or subtract as indicated and write the result in standard form.**

1)  $(5 - 6i) + (9 + 9i)$

A)  $14 + 3i$

B)  $14 - 3i$

C)  $-4 + 15i$

D)  $-14 - 3i$

2)  $(9 + 5i) - (-8 + i)$

A)  $17 + 4i$

B)  $17 - 4i$

C)  $1 + 6i$

D)  $-17 - 4i$

3)  $8i + (-7 - i)$

A)  $-7 + 7i$

B)  $-7 + 9i$

C)  $7 - 7i$

D)  $7 - 9i$

4)  $5i - (-5 - i)$

A)  $5 + 6i$

B)  $-5 - 6i$

C)  $5 - 4i$

D)  $-5 + 4i$

5)  $(-7 + 6i) - 9$

A)  $-16 + 6i$

B)  $16 - 6i$

C)  $2 + 6i$

D)  $2 - 6i$

6)  $-2 - (-2 - 8i) - (-2 - 6i)$

A)  $2 + 14i$

B)  $2 - 14i$

C)  $4 - 14i$

D)  $4 + 14i$

7)  $(4 - 3i) + (1 - 6i) + (4 + 5i)$

A)  $9 - 4i$

B)  $7 + 8i$

C)  $1 - 14i$

D)  $5 - 9i$

#### 2 Multiply Complex Numbers

**MULTIPLE CHOICE.** Choose the one alternative that best completes the statement or answers the question.

**Find the product and write the result in standard form.**

1)  $-5i(3i - 9)$

A)  $15 + 45i$

B)  $-15 + 45i$

C)  $45i - 15i^2$

D)  $45i + 15i^2$

2)  $7i(-3i + 6)$

A)  $21 + 42i$

B)  $-21 + 42i$

C)  $42i - 21i^2$

D)  $42i + 21i^2$

3)  $(9 + 8i)(5 - 5i)$

A)  $85 - 5i$

B)  $85 + 5i$

C)  $5 + 85i$

D)  $-40i^2 - 5i + 45$

4)  $(-6 + 9i)(5 + i)$

A)  $-39 + 39i$

B)  $-21 + 39i$

C)  $-39 - 51i$

D)  $-21 - 51i$

5)  $(8 - 6i)(-5 - 3i)$

A)  $-58 + 6i$

B)  $-58 - 54i$

C)  $-22 + 6i$

D)  $-22 - 54i$

6)  $(9 + 3i)(9 - 3i)$

A) 90

B)  $81 - 9i^2$

C) 72

D)  $81 - 9i$

$$7) (-4 + i)(-4 - i)$$

A) 17

B) -4

C) 16

D) -15

$$8) (4 + 9i)^2$$

A)  $-65 + 72i$

B)  $97 + 72i$

C) -65

D)  $16 + 72i + 81i^2$

Perform the indicated operations and write the result in standard form.

$$9) (7 + 8i)(3 - i) - (1 - i)(1 + i)$$

A)  $27 + 17i$

B)  $31 + 17i$

C)  $29 + 17i$

D)  $27 + 31i$

$$10) (2 + i)^2 - (6 - i)^2$$

A)  $-32 + 16i$

B)  $32 + 16i$

C) -48

D)  $-32 - 16i$

Complex numbers are used in electronics to describe the current in an electric circuit. Ohm's law relates the current in a circuit,  $I$ , in amperes, the voltage of the circuit,  $E$ , in volts, and the resistance of the circuit,  $R$ , in ohms, by the formula  $E = IR$ . Solve the problem using this formula.

11) Find  $E$ , the voltage of a circuit, if  $I = (8 + 9i)$  amperes and  $R = (4 + 7i)$  ohms.

A)  $(-31 + 92i)$  volts

B)  $(-31 - 92i)$  volts

C)  $(92 - 31i)$  volts

D)  $(92 + 31i)$  volts

12) Find  $E$ , the voltage of a circuit, if  $I = (18 + i)$  amperes and  $R = (2 + 3i)$  ohms.

A)  $(33 + 56i)$  volts

B)  $(33 - 56i)$  volts

C)  $(-18 + 56i)$  volts

D)  $(-18 - 56i)$  volts

### 3 Divide Complex Numbers

MULTIPLE CHOICE. Choose the one alternative that best completes the statement or answers the question.

Divide and express the result in standard form.

$$\frac{7}{8 - i}$$

A)  $\frac{56}{65} + \frac{7i}{65}$

B)  $\frac{56}{65} - \frac{7i}{65}$

C)  $\frac{8}{9} + \frac{1i}{9}$

D)  $\frac{8}{9} - \frac{1i}{9}$

$$2) \frac{8}{2 + i}$$

A)  $\frac{16}{5} - \frac{8i}{5}$

B)  $\frac{16}{5} + \frac{8i}{5}$

C)  $\frac{16}{3} + \frac{8i}{3}$

D)  $\frac{16}{3} - \frac{8i}{3}$

$$\frac{10i}{3 + i}$$

A)  $1 + 3i$

B)  $-1 + 3i$

C)  $1 + 10i$

D)  $1 - 3i$

$$4i$$

$$\frac{4i}{3 + i}$$

A)  $\frac{2}{5} + \frac{6i}{5}$

B)  $-\frac{2}{5} + \frac{6i}{5}$

C)  $\frac{1}{2} + \frac{3i}{2}$

D)  $\frac{2}{5} - \frac{6i}{5}$

$$\frac{2i}{1 + 7i}$$

A)  $\frac{7}{25} + \frac{1i}{25}$

B)  $\frac{1}{25} + \frac{7i}{25}$

C)  $-\frac{7}{24} + \frac{1i}{24}$

D)  $-\frac{1}{24} - \frac{7i}{24}$

$$\frac{4 + 5i}{5 - 4i}$$

$$-i$$

$$C) 1$$

$$-1$$

$$\frac{4 - 31i}{3 + 4i}$$

$$\frac{2 - 31i}{7 - 28}$$

$$\frac{32 + 1i}{25 - 25}$$

$$\frac{16 - 31i}{7 - 28}$$

$$\frac{2 + 3i}{5 + 2i}$$

$$\frac{1 + 1i}{72 - 24}$$

$$\frac{13 - 9i}{2 - 2}$$

$$\frac{13 + 1i}{24 - 24}$$

$$\frac{5 + 8i}{4 + 2i}$$

$$\frac{16 + 11i}{21 - 21}$$

$$\frac{4 - 19i}{29 - 29}$$

$$\frac{+ 11i}{21 - 21}$$

$$\frac{4 - 3i}{5 - 3i}$$

$$\frac{29 - 3i}{34 - 34}$$

$$B) \frac{3 + 11i}{2 - 12}$$

$$C) \frac{2 - 21i}{5 - 5}$$

$$\frac{1 + 11i}{3 - 12}$$

$$\frac{29 - 3}{16 - 16i}$$

$$\frac{11 + 27}{34 - 34i}$$

$$\frac{11 - 3i}{16 - 16}$$

#### 4 Perform Operations with Square Roots of Negative Numbers

MULTIPLE CHOICE. Choose the one alternative that best completes the statement or answers the question.

Perform the indicated operations and write the result in standard form.

1)  $\sqrt{-16} + \sqrt{81}$

A) 13i

B) -13i

C) 36i

D) -13

2)  $\sqrt{-3} - 3\sqrt{-121}$

A)  $i(\sqrt{3} - 11)$

B)  $\sqrt{3} - 11$

C)  $\sqrt{3} - 11i$

D)  $i(\sqrt{3} + 11)$

3)  $3\sqrt{-64} + 4\sqrt{-49}$

A) 52i

B) -52

C) 52

D) -52i

4)  $2\sqrt{-32} + 5\sqrt{-50}$

A)  $33i\sqrt{2}$

B)  $-33\sqrt{2}$

C)  $33\sqrt{2}$

D)  $-33i\sqrt{2}$

5)  $(-8 - \sqrt{-49})^2$

A)  $15 + 112i$

B)  $113 + 112i$

C)  $64 + 49i$

D)  $64 - 49i$

$$6) (-6 + \sqrt{-100})^2$$

A)  $-64 - 120i$

B)  $136 + 120i$

C)  $36 + 100i$

D)  $36 - 100i$

$$7) (\sqrt{-64})(\sqrt{-64})$$

A) 70

B) -58

C)  $6 - 64i$

D)  $6 - 8i$

$$8) (3 + \sqrt{-3})(3 + \sqrt{-2})$$

A)  $(9 - \sqrt{6}) + (3\sqrt{2} + 3\sqrt{3})i$

C)  $3 - 6\sqrt{6}i$

B)  $(9 + \sqrt{6}) - 15i$

D)  $15 + 36i$

$$9) \frac{-2 + \sqrt{-12}}{2}$$

A)  $-1 + i\sqrt{3}$

$\frac{-42 - \sqrt{52}}{6}$

A)  $-7 - i\sqrt{7}$

B)  $-1 - i\sqrt{3}$

C)  $1 + i\sqrt{3}$

D)  $-1 + i\sqrt{3}$

B)  $-7 + i\sqrt{7}$

C)  $7 + i\sqrt{7}$

D)  $-7 - i\sqrt{7}$

$$11) \sqrt{16(5 - 9i)}$$

A)  $12 + 20i$

B)  $20i - 12$

C)  $20i - 12i^2$

D)  $20i + 12i^2$

$$12) (\sqrt{9})(\sqrt{-4})$$

A) -24

B)  $24i^2$

C) 24

D) -24i

### 5 Solve Quadratic Equations with Complex Imaginary Solutions

**MULTIPLE CHOICE.** Choose the one alternative that best completes the statement or answers the question.

Solve the quadratic equation using the quadratic formula. Express the solution in standard form.

$$1) x^2 + x + 2 = 0$$

A)  $\left\{ \frac{-1 \pm i\sqrt{7}}{2} \right\}$

B)  $\left\{ \frac{-1 \pm i\sqrt{7}}{2} \right\}$

C)  $\left\{ \frac{-1 \pm i\sqrt{7}}{2} \right\}$

D)  $\left\{ \frac{-1 \pm i\sqrt{7}}{2} \right\}$

$$2) x^2 - 12x + 40 = 0$$

A)  $\{6 \pm 2i\}$

B)  $\{6 \pm 4i\}$

C)  $\{6 + 2i\}$

D)  $\{4, 8\}$

$$3) 8x^2 + 3x + 3 = 0$$

A)  $\left\{ \frac{-3 \pm i\sqrt{87}}{16} \right\}$

B)  $\left\{ \frac{-3 \pm i\sqrt{87}}{16} \right\}$

C)  $\left\{ \frac{-3 \pm i\sqrt{87}}{16} \right\}$

D)  $\left\{ \frac{-3 \pm i\sqrt{87}}{16} \right\}$

$$4) 16x^2 - 5x + 1 = 0$$

A)  $\left\{ \frac{-5 \pm i\sqrt{35}}{32} \right\}$

B)  $\left\{ \frac{-5 \pm i\sqrt{35}}{32} \right\}$

C)  $\left\{ \frac{-5 \pm i\sqrt{35}}{32} \right\}$

D)  $\left\{ \frac{-5 \pm i\sqrt{35}}{32} \right\}$

$$5) 5x^2 = -9x - 7$$

A)  $\left\{ \frac{-9 \pm i\sqrt{59}}{10} \right\}$

B)  $\left\{ \frac{-9 \pm i\sqrt{59}}{10} \right\}$

C)  $\left\{ \frac{-9 \pm i\sqrt{59}}{10} \right\}$

D)  $\left\{ \frac{-9 \pm i\sqrt{59}}{10} \right\}$

## 2.2 Quadratic Functions

### 1 Recognize Characteristics of Parabolas

**MULTIPLE CHOICE.** Choose the one alternative that best completes the statement or answers the question.

The graph of a quadratic function is given. Determine the function's equation.

1)

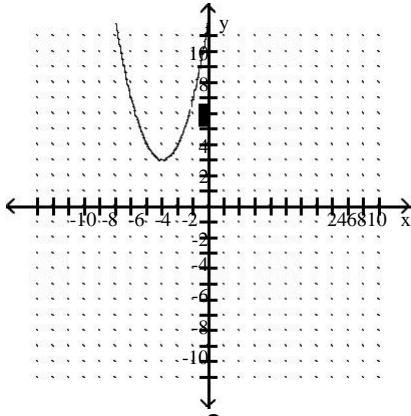

A)  $f(x) = (x + 3)^2 + 3$

B)  $g(x) = (x + 3)^2 - 3$

C)  $h(x) = (x - 3)^2 + 3$

D)  $j(x) = (x - 3)^2 - 3$

2)

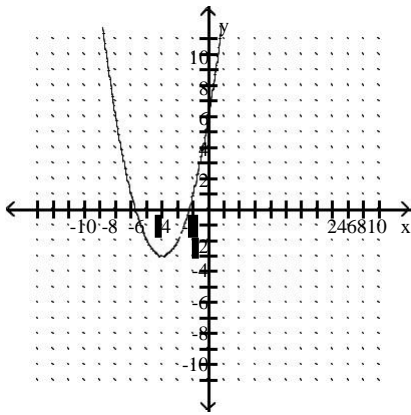

A)  $g(x) = (x + 3)^2 - 3$

B)  $f(x) = (x + 3)^2 + 3$

C)  $h(x) = (x - 3)^2 + 3$

D)  $j(x) = (x - 3)^2 - 3$

3)

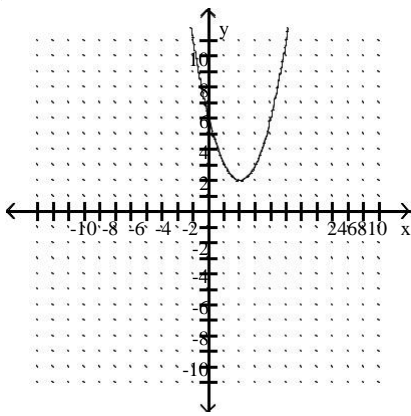

A)  $h(x) = (x - 2)^2 + 2$

B)  $g(x) = (x + 2)^2 - 2$

C)  $f(x) = (x + 2)^2 + 2$

D)  $j(x) = (x - 2)^2 - 2$

4)

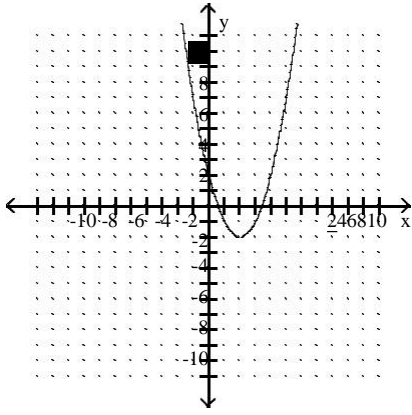

A)  $j(x) = (x - 2)^2 - 2$

B)  $g(x) = (x + 2)^2 - 2$

C)  $h(x) = (x - 2)^2 + 2$

D)  $f(x) = (x + 2)^2 + 2$

5)

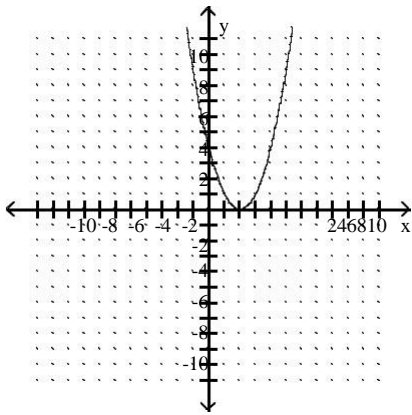

A)  $f(x) = x^2 - 4x + 4$

B)  $g(x) = x^2 + 4x + 4$

C)  $h(x) = x^2 - 2$

D)  $j(x) = x^2 + 2$

6)

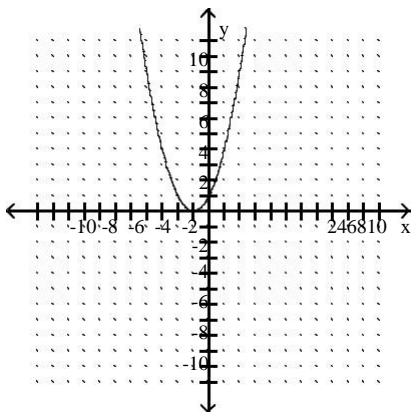

A)  $g(x) = x^2 + 2x + 1$

B)  $f(x) = x^2 - 2x + 1$

C)  $h(x) = x^2 - 1$

D)  $j(x) = x^2 + 1$



7)

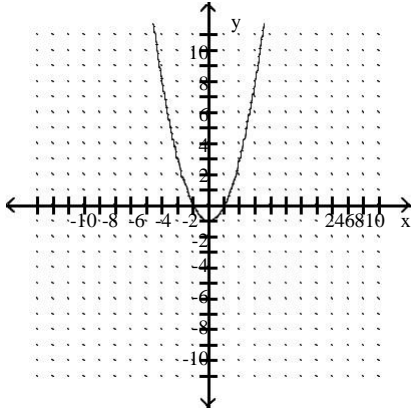

A)  $h(x) = x^2 - 1$

B)  $g(x) = x^2 + 2x + 1$

C)  $f(x) = x^2 - 2x + 1$

D)  $j(x) = x^2 + 1$

8)

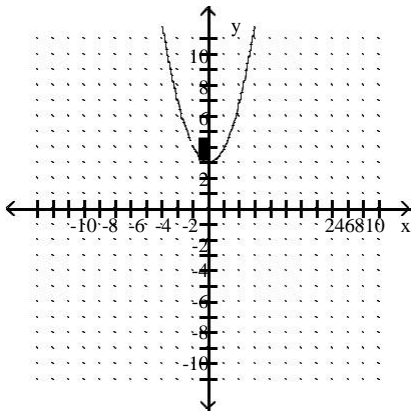

A)  $j(x) = x^2 + 3$

B)  $g(x) = x^2 + 6x + 9$

C)  $h(x) = x^2 - 3$

D)  $f(x) = x^2 - 6x + 9$

9)

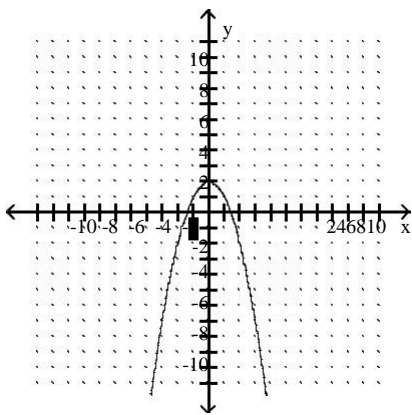

A)  $j(x) = -x^2 + 2$

B)  $g(x) = -x^2 + 4x + 4$

C)  $h(x) = -x^2 - 2$

D)  $f(x) = -x^2 - 4x - 4$

10)

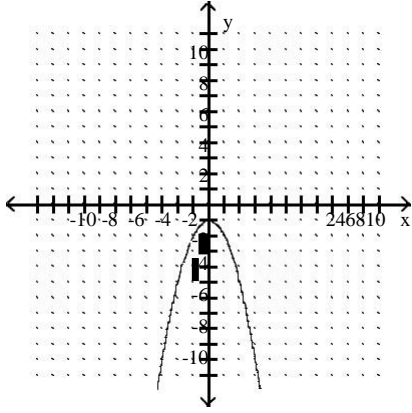

A)  $h(x) = -x^2 - 1$

B)  $g(x) = -x^2 + 2x + 1$

C)  $j(x) = -x^2 + 1$

D)  $f(x) = -x^2 - 2x - 1$

Find the coordinates of the vertex for the parabola defined by the given quadratic function.

11)  $f(x) = (x + 1)^2 + 1$

A) (-1, 1)

B) (-1, -1)

C) (0, 1)

D) (1, 0)

12)  $f(x) = x^2 + 8$

A) (0, 8)

B) (-8, 0)

C) (0, -8)

D) (8, 0)

13)  $f(x) = (x + 5)^2 + 9$

A) (-5, 9)

B) (-9, 5)

C) (9, -25)

D) (9, -5)

14)  $f(x) = 9 - (x + 5)^2$

A) (-5, 9)

B) (5, 9)

C) (9, 5)

D) (9, -5)

15)  $f(x) = (x + 3)^2 - 2$

A) (-3, -2)

B) (3, 2)

C) (3, -2)

D) (-3, 2)

16)  $y + 4 = (x + 2)^2$

A) (-2, -4)

B) (2, -4)

C) (4, -2)

D) (4, 2)

17)  $f(x) = 11(x - 5)^2 + 9$

A) (5, 9)

B) (11, 5)

C) (-5, 9)

D) (9, -5)

18)  $f(x) = -7(x - 2)^2 - 8$

A) (2, -8)

B) (-8, 2)

C) (-2, -8)

D) (-7, -2)

19)  $f(x) = x^2 - 8$

A) (0, -8)

B) (1, 0)

C) (0, 8)

D) (8, 0)

20)  $f(x) = x^2 + 12x - 1$

A) (-6, -37)

B) (6, 107)

C) (12, 287)

D) (-6, -109)

21)  $f(x) = -x^2 + 14x + 8$

A) (7, 57)

B) (-7, -139)

C) (14, 8)

D) (-7, -41)

22)  $f(x) = 8 - x^2 + 2x$

A) (1, 9)

B) (-1, 9)

C) (1, -9)

D) (-1, -9)

23)  $f(x) = -6x^2 - 12x + 4$

A) (-1, 10)

B) (1, -14)

C) (-2, -8)

D) (2, -44)

**Find the axis of symmetry of the parabola defined by the given quadratic function.**

24)  $f(x) = x^2 + 7$

A)  $x = 0$

B)  $x = 7$

C)  $x = -7$

D)  $y = 7$

25)  $f(x) = (x + 3)^2 + 7$

A)  $x = -3$

B)  $x = 3$

C)  $y = 7$

D)  $y = -7$

26)  $f(x) = 6 - (x + 3)^2$

A)  $x = -3$

B)  $x = 3$

C)  $x = 6$

D)  $x = -6$

27)  $f(x) = (x + 1)^2 - 9$

A)  $x = -1$

B)  $x = 1$

C)  $x = -9$

D)  $x = 9$

28)  $y + 9 = (x - 3)^2$

A)  $x = 3$

B)  $x = -3$

C)  $y = 9$

D)  $y = -9$

29)  $f(x) = 11(x - 3)^2 + 7$

A)  $x = 3$

B)  $x = 11$

C)  $x = -3$

D)  $x = 7$

30)  $f(x) = -7(x - 4)^2 - 6$

A)  $x = 4$

B)  $x = -6$

C)  $x = -4$

D)  $x = -7$

31)  $f(x) = x^2 + 12x - 5$

A)  $x = -6$

B)  $x = 6$

C)  $x = 12$

D)  $x = -41$

32)  $f(x) = -x^2 + 2x - 3$

A)  $x = 1$

B)  $x = -1$

C)  $x = 2$

D)  $x = -2$

33)  $f(x) = 2x^2 + 4x - 7$

A)  $x = -1$

B)  $x = 1$

C)  $x = -2$

D)  $x = -9$

**Find the range of the quadratic function.**

34)  $f(x) = x^2 + 6$

A)  $[6, \infty)$

B)  $(-\infty, 6]$

C)  $[-6, \infty)$

D)  $[0, \infty)$

35)  $f(x) = (x + 4)^2 + 8$

A)  $[8, \infty)$

B)  $[-8, \infty)$

C)  $[4, \infty)$

D)  $[-4, \infty)$

36)  $f(x) = 4 - (x + 2)^2$

A)  $(-\infty, 4]$

B)  $[4, \infty)$

C)  $(-\infty, 2]$

D)  $[-2, \infty)$

37)  $f(x) = (x + 8)^2 - 3$

A)  $[-3, \infty)$

B)  $(-\infty, -8]$

C)  $(-\infty, -3]$

D)  $[-8, \infty)$

- 38)  $y + 4 = (x - 2)^2$   
 A)  $[-4, \infty)$                       B)  $(-\infty, -2]$                       C)  $[4, \infty)$                       D)  $(-\infty, 4]$
- 39)  $f(x) = 11(x - 4)^2 + 5$   
 A)  $[5, \infty)$                       B)  $[4, \infty)$                       C)  $(-\infty, 5]$                       D)  $[-5, \infty)$
- 40)  $f(x) = -7(x - 5)^2 - 7$   
 A)  $(-\infty, -7]$                       B)  $(-\infty, 5]$                       C)  $[-7, \infty)$                       D)  $[-5, \infty)$
- 41)  $f(x) = x^2 - 8x - 8$   
 A)  $[-24, \infty)$                       B)  $[-4, \infty)$                       C)  $(-\infty, -24]$                       D)  $(-\infty, -56]$
- 42)  $f(x) = -x^2 + 10x + 3$   
 A)  $(-\infty, 28]$                       B)  $[28, \infty)$                       C)  $[5, \infty)$                       D)  $(-\infty, 5]$
- 43)  $f(x) = 2x^2 + 3x - 9$   
 A)  $[-\frac{81}{8}, \infty)$                       B)  $(-\infty, -\frac{81}{8}]$                       C)  $[-\frac{3}{4}, \infty)$                       D)  $(-\infty, -\frac{3}{4}]$
- 44)  $f(x) = -3x^2 - 6x$   
 A)  $(-\infty, 3]$                       B)  $(-\infty, -3]$                       C)  $(-\infty, -1]$                       D)  $(-\infty, 1]$

**Find the x-intercepts (if any) for the graph of the quadratic function.**

- 45)  $f(x) = x^2 - 4$   
 A)  $(-2, 0)$  and  $(2, 0)$                       B)  $(-4, 0)$                       C)  $(2, 0)$                       D) No x-intercepts
- 46)  $f(x) = (x - 1)^2 - 1$   
 A)  $(0, 0)$  and  $(2, 0)$                       B)  $(0, 0)$  and  $(-2, 0)$                       C)  $(0, 0)$  and  $(-1, 0)$                       D)  $(-2, 0)$  and  $(2, 0)$
- 47)  $y + 4 = (x - 2)^2$   
 A)  $(0, 0)$  and  $(4, 0)$                       B)  $(0, 0)$  and  $(-4, 0)$                       C)  $(-4, 0)$  and  $(4, 0)$                       D)  $(0, 0)$
- 48)  $f(x) = 4 + 5x + x^2$   
 A)  $(-1, 0)$  and  $(-4, 0)$                       B)  $(1, 0)$  and  $(4, 0)$                       C)  $(1, 0)$  and  $(-4, 0)$                       D)  $(-1, 0)$  and  $(4, 0)$
- 49)  $f(x) = x^2 + 18x + 67$  Give your answers in exact form.  
 A)  $(-9 \pm \sqrt{4}, 0)$                       B)  $(9 + \sqrt{4}, 0)$                       C)  $(9 \pm \sqrt{7}, 0)$                       D)  $(-18 \pm \sqrt{7}, 0)$
- 50)  $f(x) = -x^2 + 11x - 30$   
 A)  $(5, 0)$  and  $(6, 0)$                       B)  $(-5, 0)$  and  $(-6, 0)$                       C)  $(5, 0)$  and  $(-6, 0)$                       D) No x-intercepts
- 51)  $f(x) = 2x^2 - 9x + 10$   
 A)  $(2, 0)$  and  $(2.5, 0)$                       B)  $(2, 0)$  and  $(-2.5, 0)$                       C)  $(5, 0)$  and  $(1, 0)$                       D)  $(5, 0)$  and  $(-1, 0)$
- 52)  $f(x) = 2x^2 + 26x + 72$   
 A)  $(-4, 0)$  and  $(-9, 0)$                       B)  $(4, 0)$  and  $(9, 0)$                       C)  $(-4, 0)$  and  $(9, 0)$                       D)  $(4, 0)$  and  $(-9, 0)$

$$3x^2 + 6x + 2 = 0$$

Give your answers in exact form.

A)  $\left[ \frac{-3 \pm \sqrt{3}}{3}, 0 \right]$

B)  $\left[ \frac{-3 \pm \sqrt{3}}{6}, 0 \right]$

C)  $\left[ \frac{-6 \pm \sqrt{3}}{3}, 0 \right]$

D)  $\left[ \frac{-3 \pm \sqrt{3}}{3}, 0 \right]$

Find the y-intercept for the graph of the quadratic function.

54)  $f(x) = -x^2 - 2x + 8$

A) (0, 8)

B) (8, 0)

C) (0, -4)

D) (0, -8)

55)  $y + 9 = (x - 3)^2$

A) (0, 0)

B) (0, -6)

C) (0, 6)

D) (9, 0)

56)  $f(x) = 4 + 5x + x^2$

A) (0, 4)

B) (0, 1)

C) (0, -4)

D) (0, 5)

57)  $f(x) = x^2 + 5x - 6$

A) (0, -6)

B) (0, 3)

C) (0, 6)

D) (0, 5)

58)  $f(x) = (x + 3)^2 - 9$

A) (0, 0)

B) (0, 6)

C) (0, 9)

D) (0, -9)

59)  $f(x) = 4x^2 - 3x - 7$

A) (0, -7)

B) (0, 7)

C)  $\left[ 0, \frac{7}{4} \right]$

D)  $\left[ 0, -\frac{7}{4} \right]$

Find the domain and range of the quadratic function whose graph is described.

60) The vertex is (1, -14) and the graph opens up.

A) Domain:  $(-\infty, \infty)$   
Range:  $[-14, \infty)$

B) Domain:  $[1, \infty)$   
Range:  $[-14, \infty)$

C) Domain:  $(-\infty, \infty)$   
Range:  $(-\infty, -14]$

D) Domain:  $(-\infty, \infty)$   
Range:  $[1, \infty)$

61) The vertex is (-1, -10) and the graph opens down.

A) Domain:  $(-\infty, \infty)$   
Range:  $(-\infty, -10]$

B) Domain:  $(-\infty, -1]$   
Range:  $(-\infty, -10]$

C) Domain:  $(-\infty, \infty)$   
Range:  $[-10, \infty)$

D) Domain:  $(-\infty, \infty)$   
Range:  $(-\infty, -1]$

62) The minimum is 0 at  $x = -1$ .

A) Domain:  $(-\infty, \infty)$   
Range:  $[0, \infty)$

B) Domain:  $[-1, \infty)$   
Range:  $[0, \infty)$

C) Domain:  $(-\infty, \infty)$   
Range:  $(-\infty, 0]$

D) Domain:  $(-\infty, \infty)$   
Range:  $[-1, \infty)$

63) The maximum is -8 at  $x = 1$

A) Domain:  $(-\infty, \infty)$   
Range:  $(-\infty, -8]$

B) Domain:  $(-\infty, 1]$   
Range:  $(-\infty, -8]$

C) Domain:  $(-\infty, \infty)$   
Range:  $[-8, \infty)$

D) Domain:  $(-\infty, \infty)$   
Range:  $(-\infty, 1]$

Solve the problem.

Write an equation in standard form of the parabola that has the same shape as the graph of  $f(x) = 11x^2$ , but which has its vertex at (3, 4).

A)  $f(x) = 11(x - 3)^2 + 4$

B)  $f(x) = 11(x + 3)^2 + 4$

C)  $f(x) = (11x + 3)^2 + 4$

D)  $f(x) = 11(x + 4)^2 + 3$

Write an equation in standard form of the parabola that has the same shape as the graph of  $f(x) = 5x^2$ , but which has a minimum of 7 at  $x = 3$ .

A)  $f(x) = 5(x - 3)^2 + 7$

B)  $f(x) = 5(x + 3)^2 + 7$

C)  $f(x) = -5(x - 3)^2 + 7$

D)  $f(x) = 5(x + 7)^2 - 3$

Write an equation in standard form of the parabola that has the same shape as the graph of  $f(x) = -7x^2$ , but which has a maximum of 7 at  $x = 5$ .

A)  $f(x) = -7(x - 5)^2 + 7$

B)  $f(x) = -7(x + 5)^2 + 7$

C)  $f(x) = 7(x - 5)^2 + 7$

D)  $f(x) = -7(x - 5)^2 - 7$

## 2 Graph Parabolas

**MULTIPLE CHOICE.** Choose the one alternative that best completes the statement or answers the question.

Use the vertex and intercepts to sketch the graph of the quadratic function.

1)  $y - 4 = (x + 5)^2$

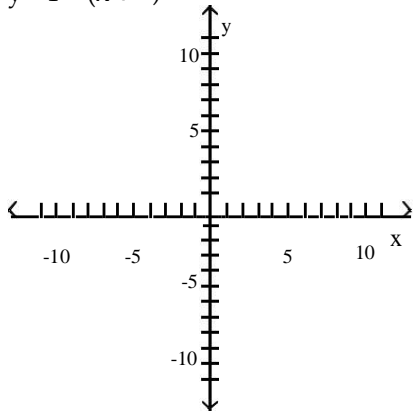

A)

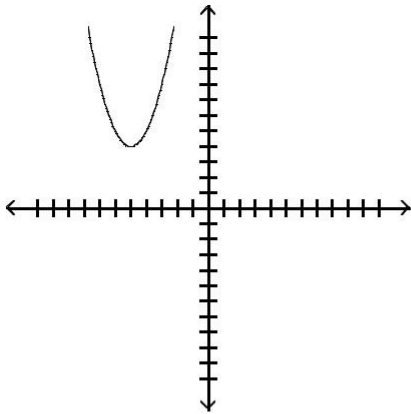

B)

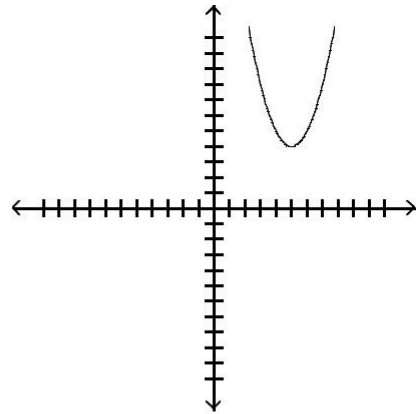

C)

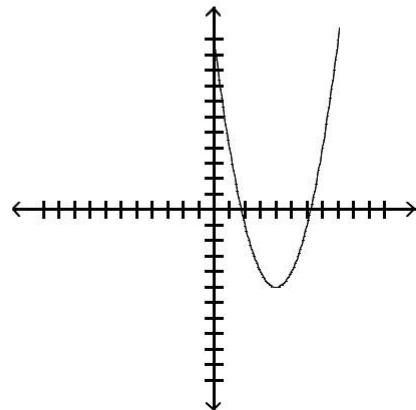
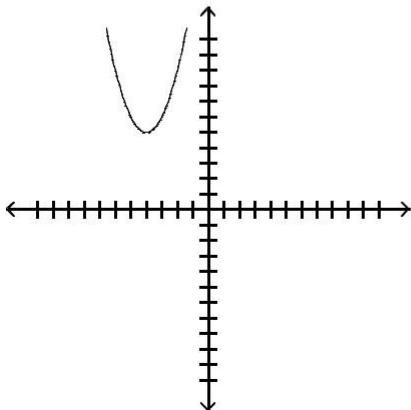

$$2) f(x) = -3(x - 6)^2 - 3$$

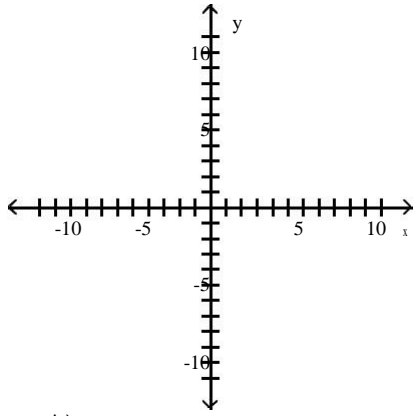

A)

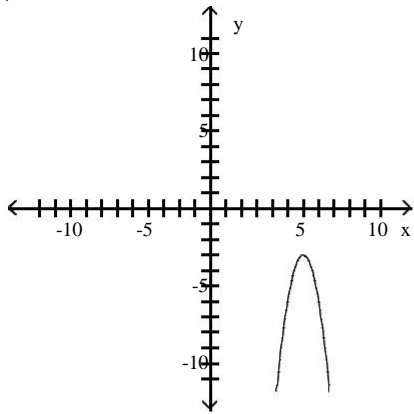

B)

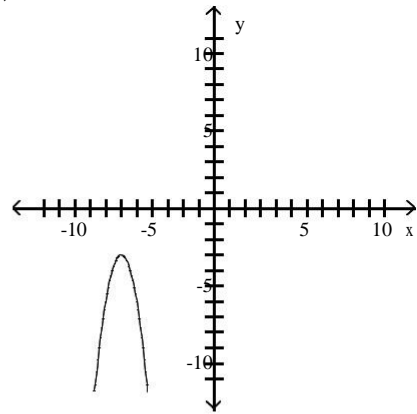

C)

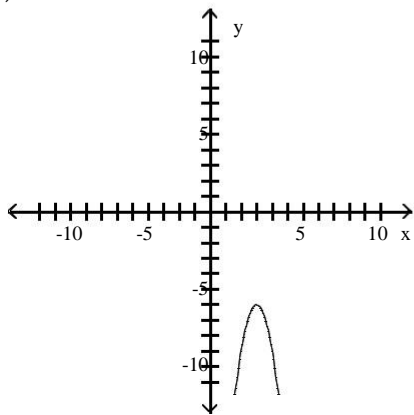

D)

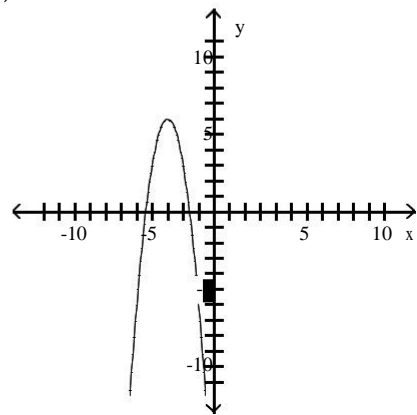



3)  $f(x) = (x - 5)^2 - 6$

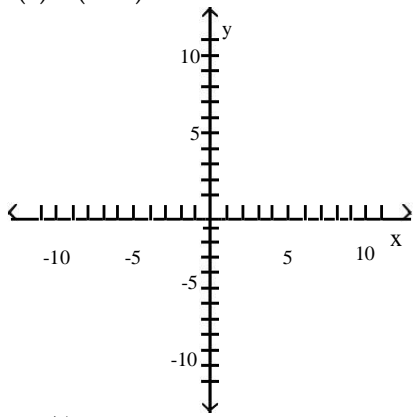

A)

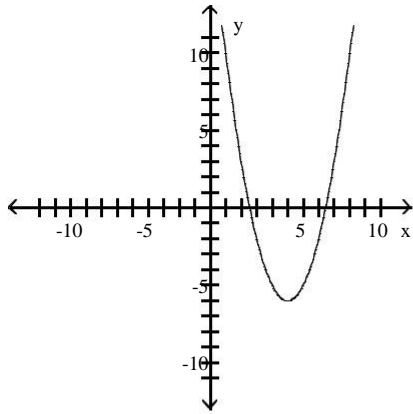

B)

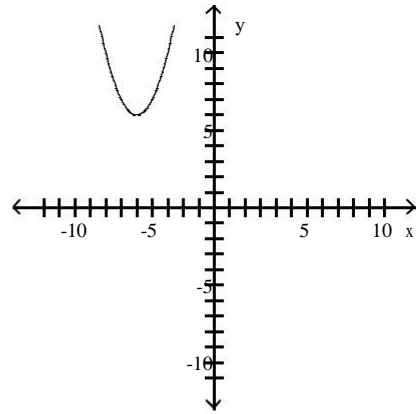

C)

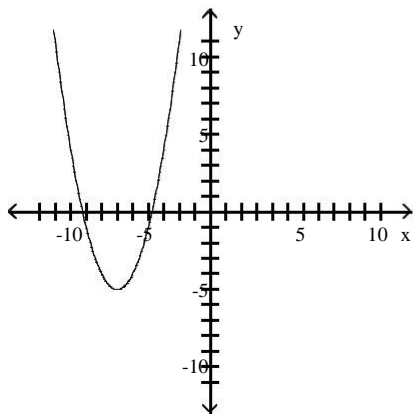

D)

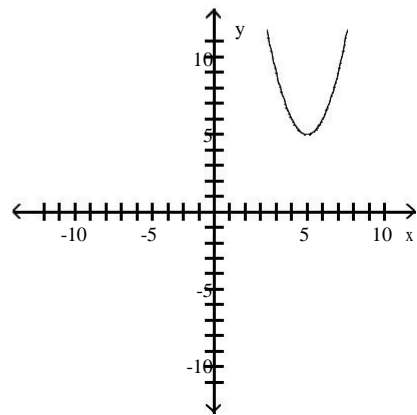

4)  $f(x) = 1 - (x + 1)^2$

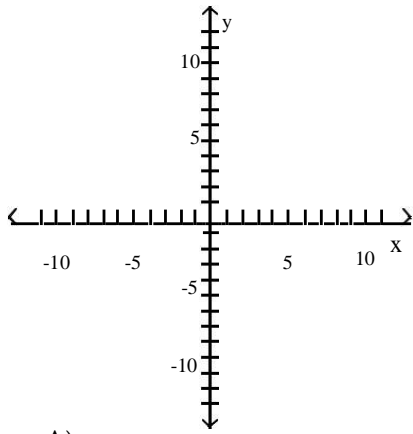

A)

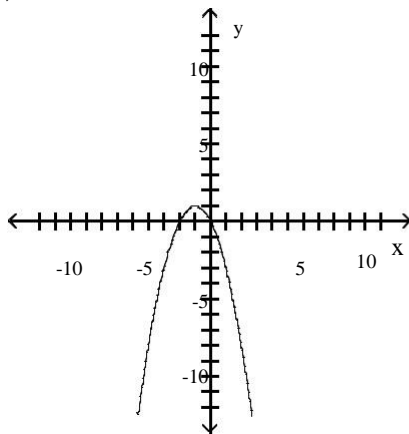

B)

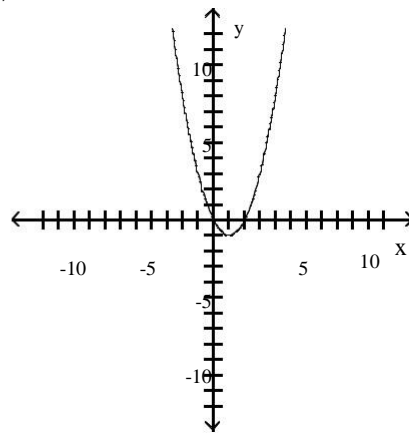

C)

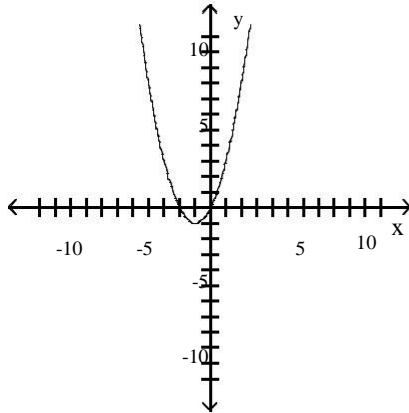

D)

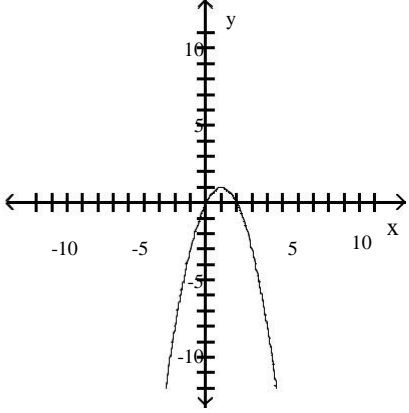

5)  $f(x) = x^2 + 6x + 5$

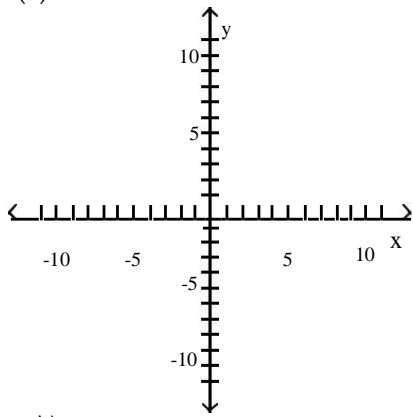

A)

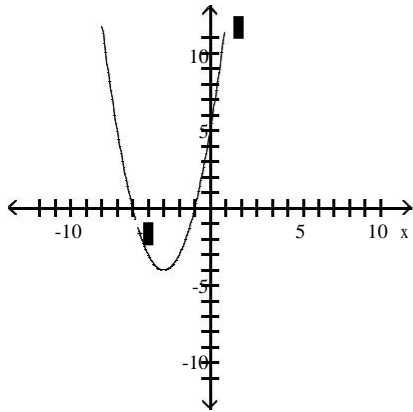

B)

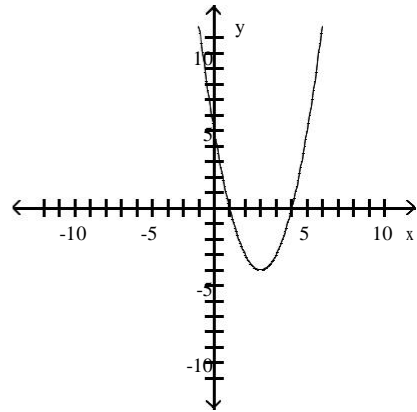

C)

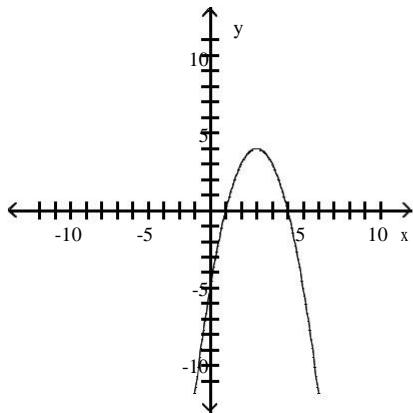

D)

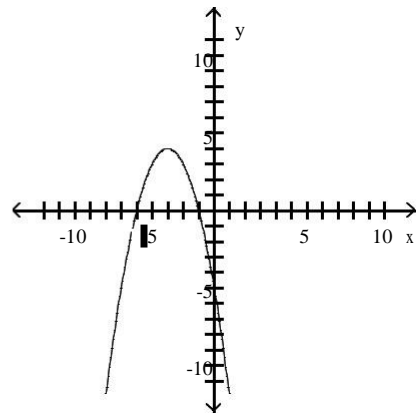

6)  $f(x) = -x^2 - 4x + 5$

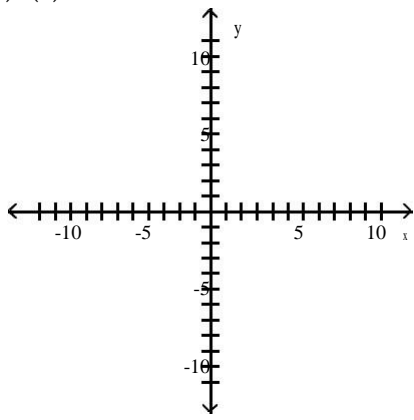

A)

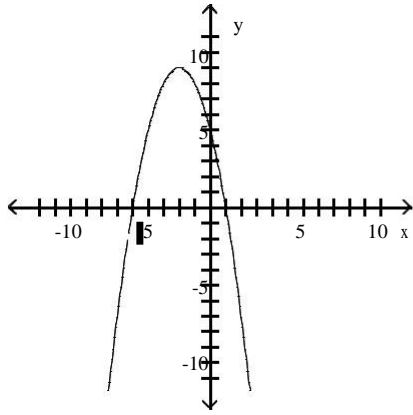

C)

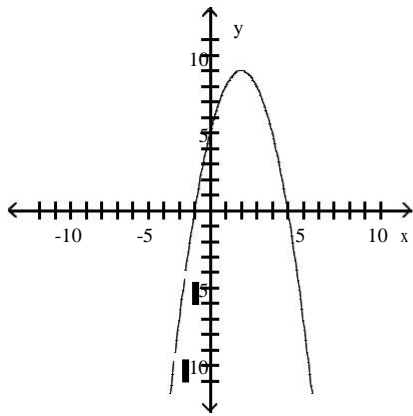

B)

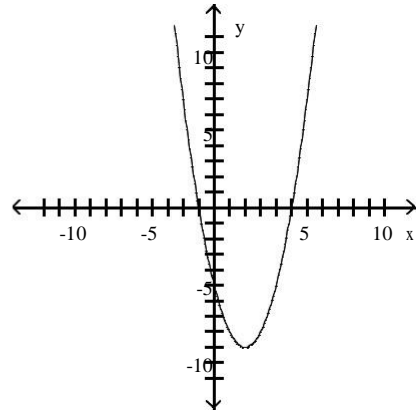

D)

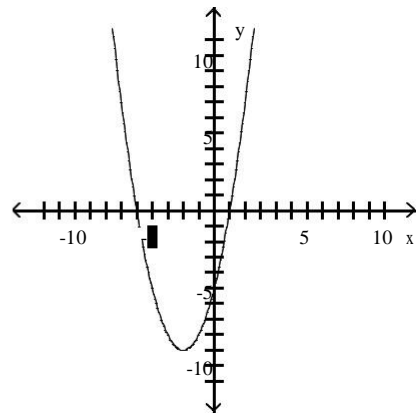

7)  $f(x) = x^2 - 8x + 7$

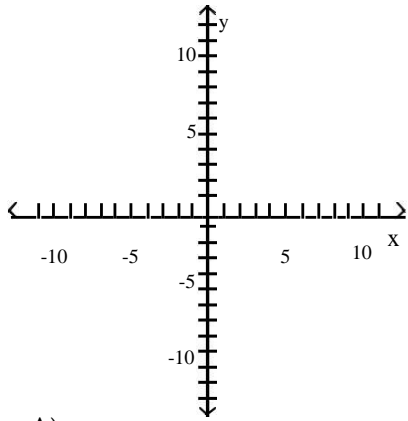

A)

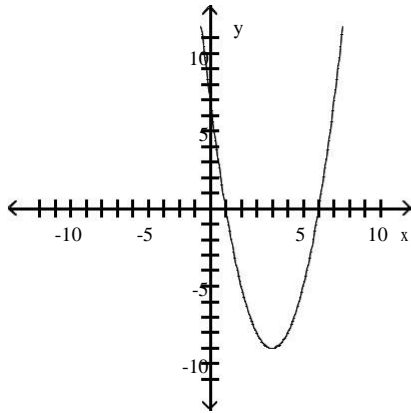

B)

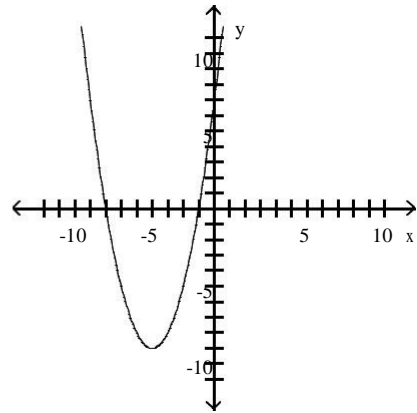

C)

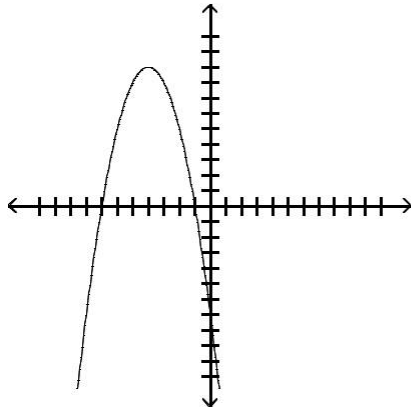

D)

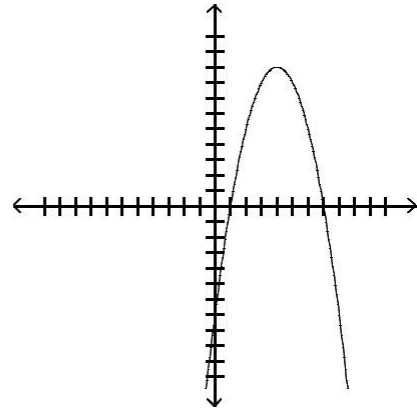

8)  $f(x) = -6x + 8 + x^2$

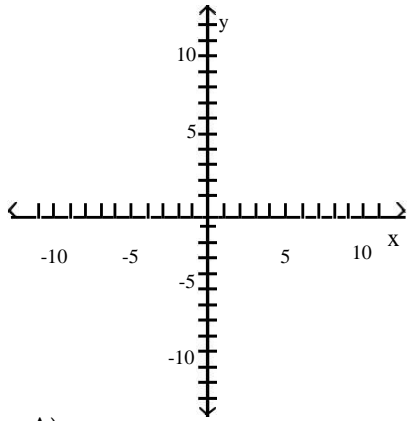

A)

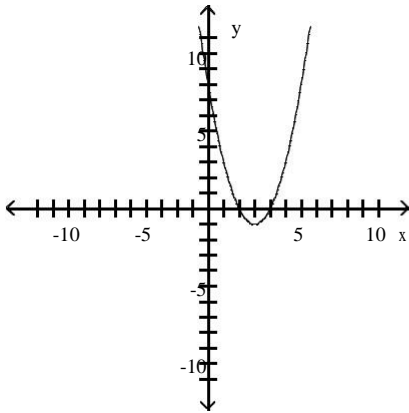

B)

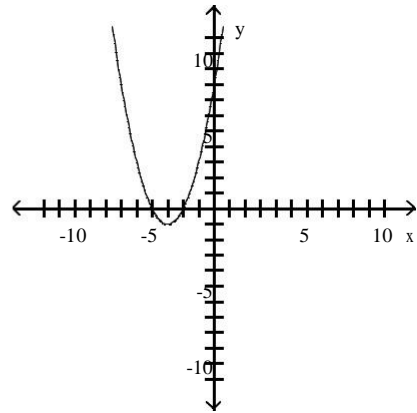

C)

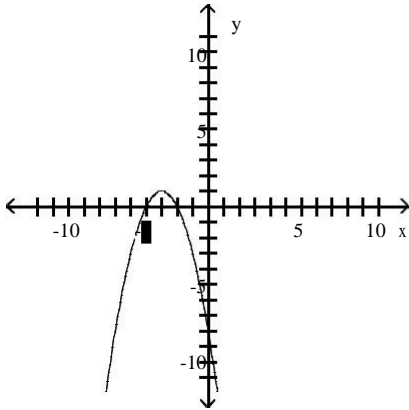

D)

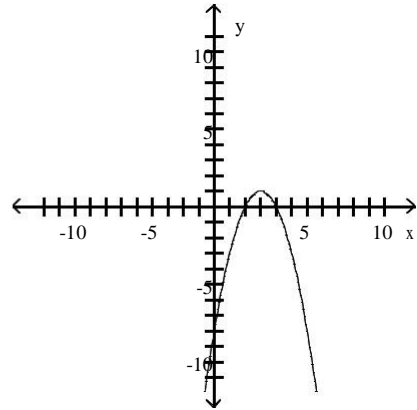

9)  $f(x) = -x^2 + 2x + 8$

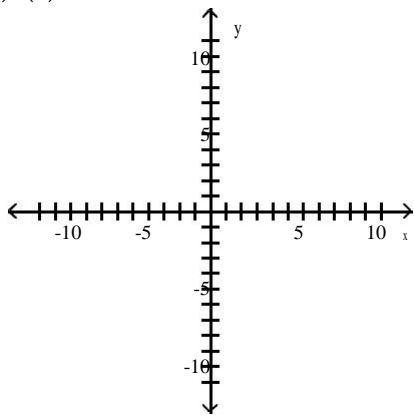

A)

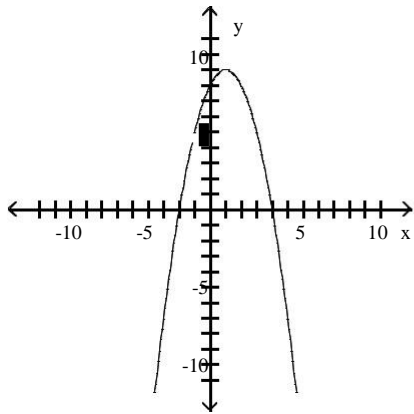

C)

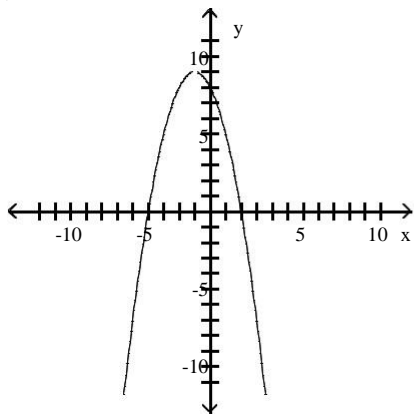

B)

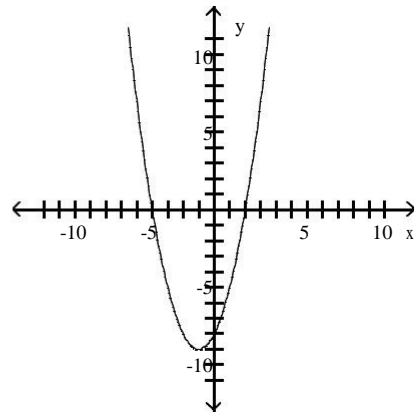

D)

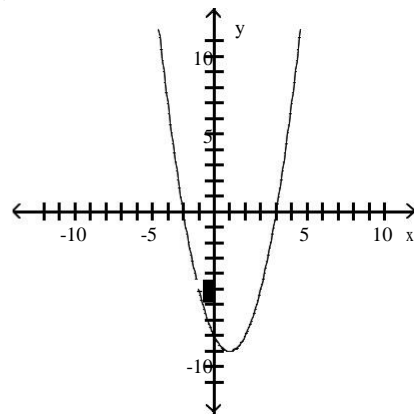

10)  $f(x) = 3 - x^2 - 2x$

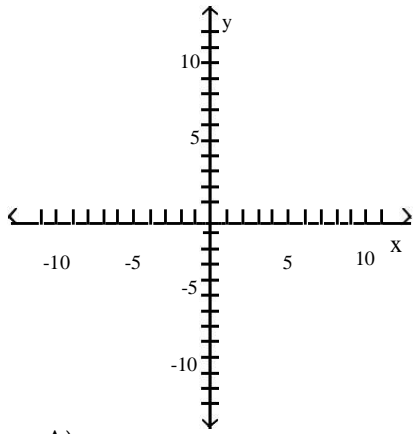

A)

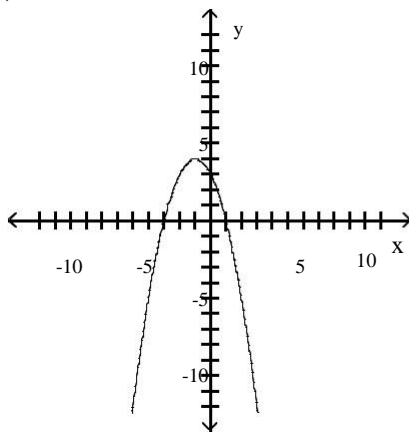

B)

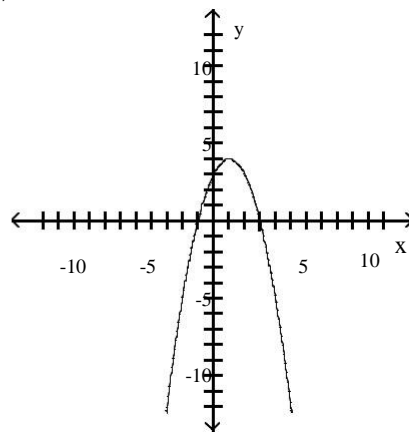

C)

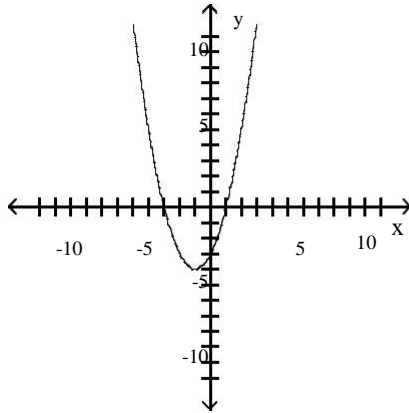

D)

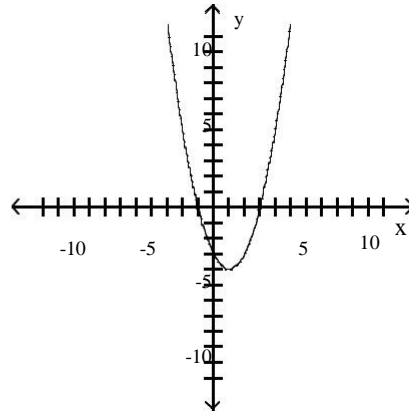



11)  $f(x) = 4 + 5x + x^2$

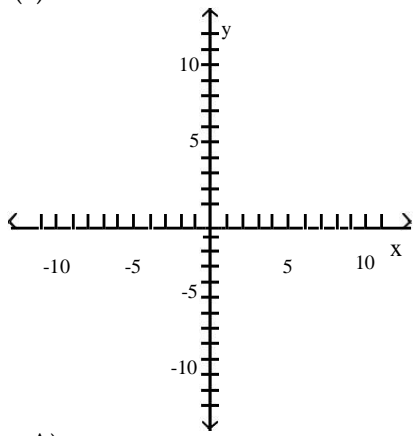

A)

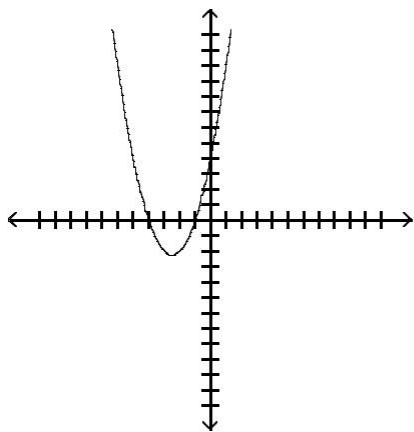

B)

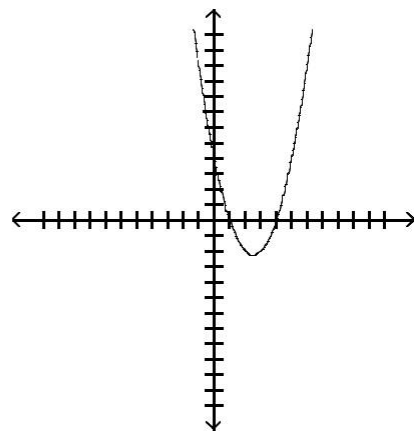

C)

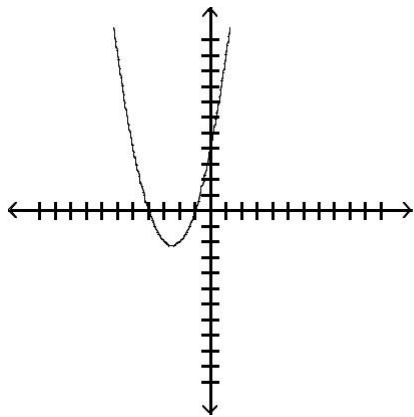

D)

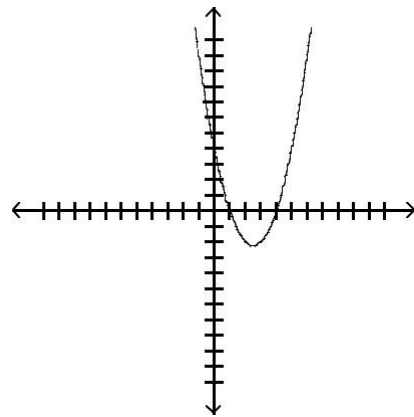

12)  $f(x) = 3x^2 + 24x + 47$

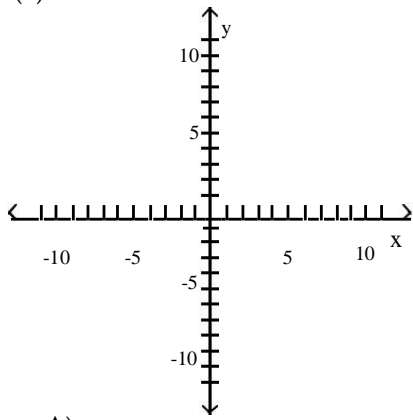

A)

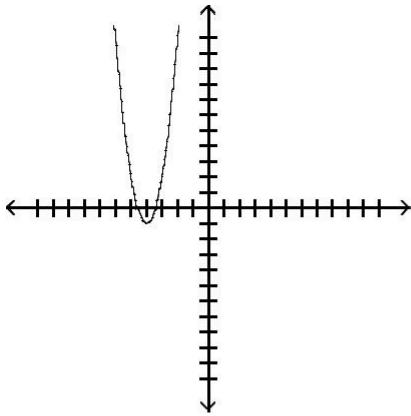

B)

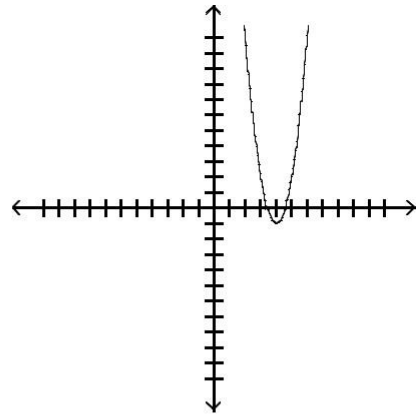

C)

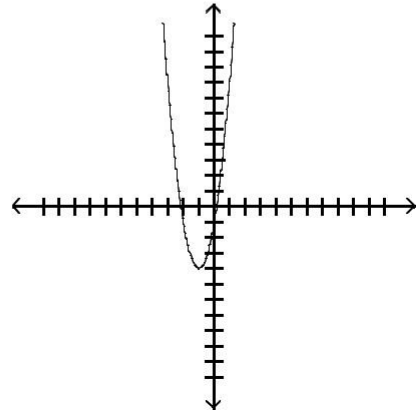
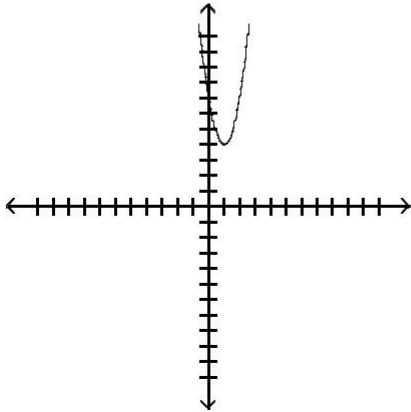

### 3 Determine a Quadratic Function's Minimum or Maximum Value

**MULTIPLE CHOICE.** Choose the one alternative that best completes the statement or answers the question.

Determine whether the given quadratic function has a minimum value or maximum value. Then find the coordinates of the minimum or maximum point.

1)  $f(x) = x^2 - 2x - 2$

A) minimum;  $(1, -3)$

B) maximum;  $(1, -3)$

C) minimum;  $(3, 1)$

D) maximum;  $(3, 1)$

2)  $f(x) = -x^2 + 2x - 1$

A) maximum;  $(1, 0)$

B) minimum;  $(1, 0)$

C) minimum;  $(0, 1)$

D) maximum;  $(0, 1)$

3)  $f(x) = 4x^2 - 2x - 2$

- A) minimum;  $\left\{ \begin{matrix} 1 & -9 \\ 4 & 4 \end{matrix} \right\}$   
 C) minimum;  $\left\{ \begin{matrix} -9 & 1 \\ 4 & 4 \end{matrix} \right\}$

- B) maximum;  $\left\{ \begin{matrix} 1 & -9 \\ 4 & 4 \end{matrix} \right\}$   
 D) maximum;  $\left\{ \begin{matrix} -9 & 1 \\ 4 & 4 \end{matrix} \right\}$

4)  $f(x) = 4x^2 + 8x$

- A) minimum;  $\left\{ \begin{matrix} -1 & -4 \\ 1 & -4 \end{matrix} \right\}$   
 C) minimum;  $\left\{ \begin{matrix} 1 & -4 \\ 1 & -4 \end{matrix} \right\}$

- B) maximum;  $\left\{ \begin{matrix} -1 & -4 \\ 1 & -4 \end{matrix} \right\}$   
 D) maximum;  $\left\{ \begin{matrix} 1 & -4 \\ 1 & -4 \end{matrix} \right\}$

5)  $f(x) = -5x^2 - 15x$

- A) maximum;  $\left\{ \begin{matrix} -3 & 45 \\ 2 & 4 \end{matrix} \right\}$   
 C) minimum;  $\left\{ \begin{matrix} 3 & -45 \\ 2 & 4 \end{matrix} \right\}$

- B) minimum;  $\left\{ \begin{matrix} -3 & 45 \\ 2 & 4 \end{matrix} \right\}$   
 D) maximum;  $\left\{ \begin{matrix} 3 & -45 \\ 2 & 4 \end{matrix} \right\}$

#### 4 Solve Problems Involving a Quadratic Function's Minimum or Maximum Value

**MULTIPLE CHOICE.** Choose the one alternative that best completes the statement or answers the question.

**Solve the problem.**

- 1) You have 300 feet of fencing to enclose a rectangular region. Find the dimensions of the rectangle that maximize the enclosed area.  
 A) 75 ft by 75 ft                      B) 150 ft by 150 ft                      C) 150 ft by 37.5 ft                      D) 77 ft by 73 ft

A developer wants to enclose a rectangular grassy lot that borders a city street for parking. If the developer has 296 feet of fencing and does not fence the side along the street, what is the largest area that can be enclosed?

- A) 10,952 ft<sup>2</sup>                      B) 21,904 ft<sup>2</sup>                      C) 5476 ft<sup>2</sup>                      D) 16,428 ft<sup>2</sup>

- 3) You have 120 feet of fencing to enclose a rectangular region. What is the maximum area?  
 A) 900 square feet                      B) 3600 square feet                      C) 14,400 square feet                      D) 896 square feet

You have 120 feet of fencing to enclose a rectangular plot that borders on a river. If you do not fence the side along the river, find the length and width of the plot that will maximize the area.

- A) length: 60 feet, width: 30 feet                      B) length: 90 feet, width: 30 feet  
 C) length: 60 feet, width: 60 feet                      D) length: 30 feet, width: 30 feet

A rain gutter is made from sheets of aluminum that are 18 inches wide by turning up the edges to form right angles. Determine the depth of the gutter that will maximize its cross-sectional area and allow the greatest amount of water to flow.

- A) 4.5 inches                      B) 4 inches                      C) 5 inches                      D) 5.5 inches

- 6) A rectangular playground is to be fenced off and divided in two by another fence parallel to one side of the playground. 648 feet of fencing is used. Find the dimensions of the playground that maximize the total enclosed area.  
 A) 108 ft by 162 ft                      B) 162 ft by 162 ft                      C) 54 ft by 243 ft                      D) 81 ft by 162 ft

A rectangular playground is to be fenced off and divided in two by another fence parallel to one side of the playground. 600 feet of fencing is used. Find the maximum area of the playground.

A)  $15,000 \text{ ft}^2$

B)  $22,500 \text{ ft}^2$

C)  $11,250 \text{ ft}^2$

D)  $16,875 \text{ ft}^2$

- 8) The cost in millions of dollars for a company to manufacture  $x$  thousand automobiles is given by the function  $C(x) = 4x^2 - 24x + 81$ . Find the number of automobiles that must be produced to minimize the cost.
- A) 3 thousand automobiles  
 B) 6 thousand automobiles  
 C) 45 thousand automobiles  
 D) 12 thousand automobiles

In one U.S. city, the quadratic function  $f(x) = 0.0041x^2 - 0.48x + 36.07$  models the median, or average, age,  $y$ , at which men were first married  $x$  years after 1900. In which year was this average age at a minimum? (Round to the nearest year.) What was the average age at first marriage for that year? (Round to the nearest tenth.)

A) 1959, 22 years old  
 B) 1959, 50.1 years old  
 C) 1936, 50.1 years old  
 D) 1953, 36 years old

- 10) The profit that the vendor makes per day by selling  $x$  pretzels is given by the function  $P(x) = -0.002x^2 + 1.6x - 200$ . Find the number of pretzels that must be sold to maximize profit.
- A) 400 pretzels  
 B) 800 pretzels  
 C) 0.8 pretzels  
 D) 120 pretzels

The manufacturer of a CD player has found that the revenue  $R$  (in dollars) is  $R(p) = -5p^2 + 1800p$ , when the unit price is  $p$  dollars. If the manufacturer sets the price  $p$  to maximize revenue, what is the maximum revenue to the nearest whole dollar?

A) \$162,000  
 B) \$324,000  
 C) \$648,000  
 D) \$1,296,000

The owner of a video store has determined that the profits  $P$  of the store are approximately given by  $P(x) = -x^2 + 20x + 51$ , where  $x$  is the number of videos rented daily. Find the maximum profit to the nearest dollar.

A) \$151  
 B) \$100  
 C) \$251  
 D) \$200

- 13) The owner of a video store has determined that the cost  $C$ , in dollars, of operating the store is approximately given by  $C(x) = 2x^2 - 28x + 730$ , where  $x$  is the number of videos rented daily. Find the lowest cost to the nearest dollar.
- A) \$632  
 B) \$338  
 C) \$534  
 D) \$828

The daily profit in dollars of a specialty cake shop is described by the function  $P(x) = -5x^2 + 210x - 1600$ , where  $x$  is the number of cakes prepared in one day. The maximum profit for the company occurs at the vertex of the parabola. How many cakes should be prepared per day in order to maximize profit?

A) 21 cakes  
 B) 2205 cakes  
 C) 441 cakes  
 D) 42 cakes

- 15) Among all pairs of numbers whose sum is 56, find a pair whose product is as large as possible.
- A) 28 and 28  
 B) 14 and 14  
 C) 30 and 26  
 D) 55 and 1

- 16) Among all pairs of numbers whose difference is 26, find a pair whose product is as small as possible.
- A) -13 and 13  
 B) 13 and 13  
 C) -39 and -13  
 D) 39 and 13

An arrow is fired into the air with an initial velocity of 160 feet per second. The height in feet of the arrow  $t$  seconds after it was shot into the air is given by the function  $h(x) = -16t^2 + 160t$ . Find the maximum height of the arrow.

A) 400 ft  
 B) 80 ft  
 C) 1200 ft  
 D) 720 ft

A person standing close to the edge on top of a 144-foot building throws a baseball vertically upward. The quadratic function  $s(t) = -16t^2 + 64t + 144$  models the ball's height above the ground,  $s(t)$ , in feet,  $t$  seconds after it was thrown. After how many seconds does the ball reach its maximum height? Round to the nearest tenth of a second if necessary.

- A) 2 seconds                      B) 5.6 seconds                      C) 208 seconds                      D) 1.5 seconds

19) April shoots an arrow upward into the air at a speed of 64 feet per second from a platform that is 30 feet high. The height of the arrow is given by the function  $h(t) = -16t^2 + 64t + 30$ , where  $t$  is the time in seconds. What is the maximum height of the arrow?

- A) 94 ft                      B) 26 ft                      C) 64 ft                      D) 30 ft

20) An object is propelled vertically upward from the top of a 80-foot building. The quadratic function  $s(t) = -16t^2 + 112t + 80$  models the ball's height above the ground,  $s(t)$ , in feet,  $t$  seconds after it was thrown. How many seconds does it take until the object finally hits the ground? Round to the nearest tenth of a second if necessary.

- A) 7.7 seconds                      B) 0.7 seconds                      C) 3.5 seconds                      D) 2 seconds

## 2.3 Polynomial Functions and Their Graphs

### 1 Identify Polynomial Functions

**MULTIPLE CHOICE.** Choose the one alternative that best completes the statement or answers the question.

**Determine whether the function is a polynomial function.**

1)  $f(x) = 4x + 6x^4$

- A) Yes                      B) No

2)  $f(x) = \frac{5 - x^3}{6}$

- A) Yes                      B) No

3)  $f(x) = 9 - \frac{2}{x^3}$

- A) No                      B) Yes

$f(x) = \frac{x^4 - 8}{x^5}$

- A) No                      B) Yes

5)  $f(x) = \sqrt[2]{x^3} - x^2 - 7$

- A) No                      B) Yes

$f(x) = -15x^5 + 9x + \frac{5}{x}$

- A) No                      B) Yes

7)  $f(x) = \pi x^5 + 6x^4 + 3$

- A) Yes                      B) No

$$8) f(x) = x^{3/2} - x^5 + 3$$

A) No

B) Yes

$$9) f(x) = 5x^7 - x^5 + \frac{4x}{3}$$

A) Yes

B) No

$$10) f(x) = 4x^3 + 5x^2 - 4x^{-4} + 80$$

A) No

B) Yes

**Find the degree of the polynomial function.**

$$11) f(x) = -4x + 6x^3$$

A) 3

B) 1

C) -4

D) 6

$$12) f(x) = \frac{8 - x^3}{5}$$

A) 3

B)  $-\frac{1}{5}$

C) 0

D) 8

$$13) f(x) = \pi x^4 + 6x^3 - 8$$

A) 4

B) 3

C)  $\pi$

D) 1

$$14) f(x) = 5x - x^2 + \frac{5}{4}$$

A) 2

B) 1

C) 5

D) -1

$$15) g(x) = -17x^4 - 9$$

A) 4

B) 5

C) 0

D) -17

$$16) h(x) = -7x + 3$$

A) 1

B) 2

C) 0

D) -7

$$17) 14x^3 + 5x^2 - 2x + 3y^4 + 2$$

A) 4

B) 3

C) 10

D) 14

$$18) f(x) = 11x^3 - 7x^2 + 4$$

A) 3

B) 6

C) -7

D) 11

## 2 Recognize Characteristics of Graphs of Polynomial Functions

**MULTIPLE CHOICE.** Choose the one alternative that best completes the statement or answers the question.

Determine whether the graph shown is the graph of a polynomial function.

1)

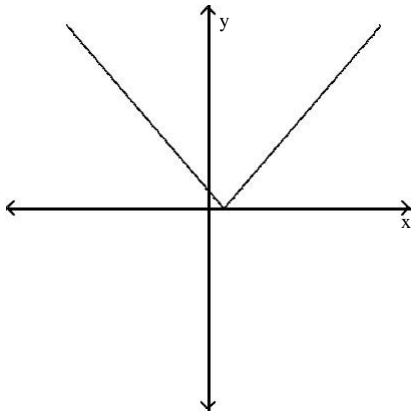

A) not a polynomial function

B) polynomial function

2)

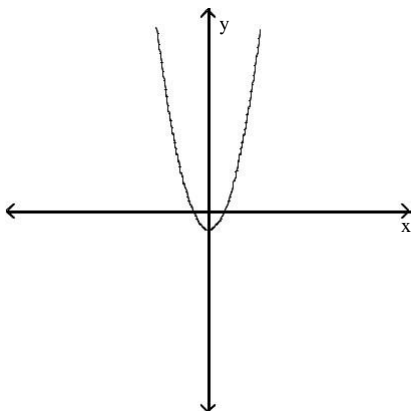

A) polynomial function

B) not a polynomial function

3)

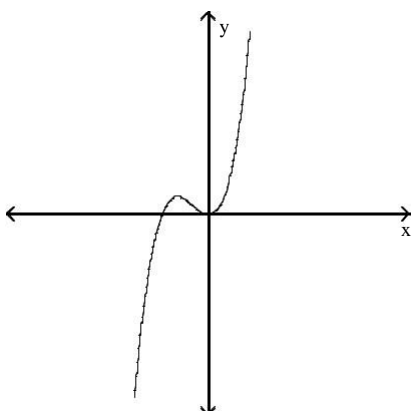

A) polynomial function

B) not a polynomial function



4)

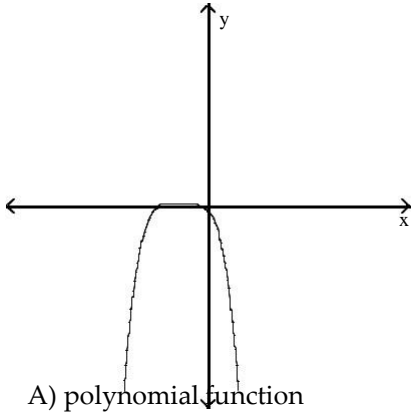

A) polynomial function

B) not a polynomial function

5)

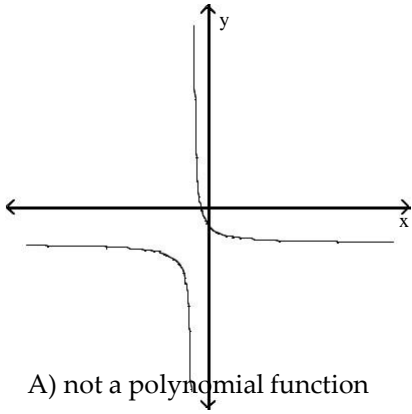

A) not a polynomial function

B) polynomial function

6)

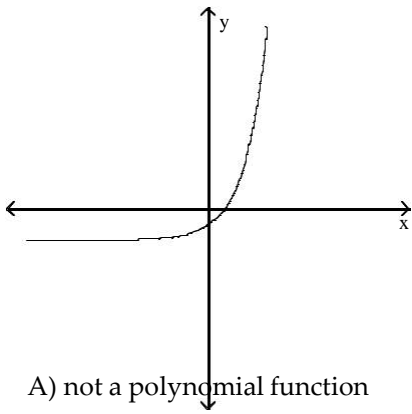

A) not a polynomial function

B) polynomial function

Find the x-intercepts of the polynomial function. State whether the graph crosses the x-axis, or touches the x-axis and turns around, at each intercept.

$$f(x) = 3x^2 - x^3$$

0, touches the x-axis and turns around;  
3, crosses the x-axis

0, crosses the x-axis; 3,  
 $\sqrt{3}$  crosses the x-axis;  
 $\sqrt{3}$ , crosses the x-axis

0, touches the x-axis and turns around;  
 $\sqrt{3}$ , crosses the x-axis;  
 $\sqrt{3}$ , crosses the x-axis

0, touches the x-axis and turns around;  
3, touches the x-axis and turns around

$$f(x) = x^4 - 9x^2$$

0, touches the x-axis and turns around;  
3, crosses the x-axis;  
3, crosses the x-axis  
0, touches the x-axis and turns around;  
9, touches the x-axis and turns around

0, crosses the x-axis;  
3, crosses the x-axis;  
3, crosses the x-axis  
0, touches the x-axis and turns around;  
9, crosses the x-axis

$$x^5 - 21x^3 + 80x = 0$$

0, crosses the x-axis;  
4, crosses the x-axis;  
-4, crosses the x-axis;  
 $\sqrt{5}$ , crosses the x-axis;  
 $\sqrt{5}$ , crosses the x-axis  
0, crosses the x-axis;  
16, touches the x-axis and turns around;  
5, touches the x-axis and turns around

0, touches the x-axis and turns around;  
4, crosses the x-axis;  
-4, crosses the x-axis;  
 $\sqrt{5}$ , crosses the x-axis;  
 $\sqrt{5}$ , crosses the x-axis  
0, touches the x-axis and turns around;  
16, touches the x-axis and turns around;  
5, touches the x-axis and turns around

$$x^4 + 7x^3 - 44x^2 = 0$$

0, touches the x-axis and turns around;  
-11, crosses the x-axis;  
4, crosses the x-axis  
0, crosses the x-axis; -  
11, crosses the x-axis;  
4, crosses the x-axis

$\bar{A}$                        $\bar{A} \Rightarrow \bar{A} \odot$                        $\bar{A} \odot$                        $\bar{A}$   
 $\odot$

, touches the x-axis and turns around; 11,  
touches the x-axis and turns around;  
4, touches the x-axis and turns around  
0, touches the x-axis and turns around; 11,  
crosses the x-axis;  
-4, crosses the x-axis

$$f(x) = x^3 + 10x^2 + 33x + 36$$

-3, touches the x-axis and turns around; -  
4, crosses the x-axis.

-3, crosses the x-axis;  
-4, touches the x-axis and turns around

3, crosses the x-axis; -  
3, crosses the x-axis; -  
4, crosses the x-axis.

3, crosses the x-axis;  
-3, touches the x-axis and turns around; -  
4, crosses the x-axis.

$$f(x) = (x + 1)(x - 3)(x - 1)^2$$

-1, crosses the x-axis;  
 3, crosses the x-axis;  
 1, touches the x-axis and turns around  
 1, crosses the x-axis; -  
 3, crosses the x-axis;  
 -1, touches the x-axis and turns around

-1, crosses the x-axis;  
 3, crosses the x-axis;  
 1, crosses the x-axis  
 1, crosses the x-axis;  
 -3, touches the x-axis and turns around; -  
 1, touches the x-axis and turns around

$$f(x) = -x^2(x + 8)(x^2 - 1)$$

0, touches the x-axis and turns around;  
 -8, crosses the x-axis;  
 -1, crosses the x-axis;  
 1, crosses the x-axis  
 0, touches the x-axis and turns around;  
 -8, crosses the x-axis;  
 1, touches the x-axis and turns around

0, crosses the x-axis; -  
 8, crosses the x-axis; -  
 1, crosses the x-axis;  
 1, crosses the x-axis  
 0, touches the x-axis and turns around;  
 8, crosses the x-axis;  
 -1, touches the x-axis and turns around; 1,  
 touches the x-axis and turns around

$$f(x) = -x^2(x + 3)(x^2 + 1)$$

0, touches the x-axis and turns around;  
 -3, crosses the x-axis

0, touches the x-axis and turns around;  
 3, crosses the x-axis

0, touches the x-axis and turns around;  
 -3, crosses the x-axis;  
 -1, touches the x-axis and turns around

0, touches the x-axis and turns around;  
 -3, crosses the x-axis;  
 -1, crosses the x-axis;  
 1, crosses the x-axis;

$$f(x) = x^2(x - 4)(x - 1)$$

0, touches the x-axis and turns around;  
 4, crosses the x-axis;  
 1, crosses the x-axis  
 0, crosses the x-axis;  
 4, crosses the x-axis;  
 1, crosses the x-axis

0, touches the x-axis and turns around;  
 -4, crosses the x-axis;  
 -1, crosses the x-axis  
 D) 0, crosses the x-axis;  
 4, touches the x-axis and turns around;  
 1, touches the x-axis and turns around

$$f(x) = -x^3(x + 1)^2(x - 9)$$

0, crosses the x-axis;  
 -1, touches the x-axis and turns around;  
 9, crosses the x-axis  
 0, touches the x-axis and turns around; -  
 1, touches the x-axis and turns around; 9,  
 crosses the x-axis

B) 0, crosses the x-axis;  
 1, touches the x-axis and turns around;  
 -9, crosses the x-axis  
 0, touches the x-axis and turns around;  
 1, crosses the x-axis;  
 9, crosses the x-axis

$$f(x) = (x - 2)^2(x^2 - 16)$$

2, touches the x-axis and turns around;  
 -4, crosses the x-axis;  
 4, crosses the x-axis  
 2, touches the x-axis and turns around;  
 16, touches the x-axis and turns around

2, touches the x-axis and turns around; -  
 4, touches the x-axis and turns around;  
 4, touches the x-axis and turns around  
 -2, touches the x-axis and turns around;  
 16, crosses the x-axis

Find the y-intercept of the polynomial function.

18)  $f(x) = 2x - x^3$

A) 0

B) 2

C) -1

D) -2

19)  $f(x) = -x^2 + 2x + 3$

A) 3

B) -3

C) 0

D) -1

20)  $f(x) = (x + 1)(x - 8)(x - 1)^2$

A) -8

B) 8

C) 0

D) -1

21)  $f(x) = -x^2(x + 6)(x^2 - 1)$

A) 0

B) -1

C) -6

D) 6

22)  $f(x) = -x^2(x + 9)(x^2 + 1)$

A) 0

B) 1

C) 9

D) -9

23)  $f(x) = x^2(x - 1)(x - 5)$

A) 0

B) -5

C) 5

D) -1

24)  $f(x) = -x^2(x + 2)(x - 9)$

A) 0

B) -9

C) -18

D) 18

25)  $f(x) = (x - 4)^2(x^2 - 25)$

A) -400

B) 400

C) -100

D) 100

Determine whether the graph of the polynomial has y-axis symmetry, origin symmetry, or neither.

26)  $f(x) = 6x^2 - x^3$

A) y-axis symmetry

B) origin symmetry

C) neither

27)  $f(x) = 8 - x^4$

A) y-axis symmetry

B) origin symmetry

C) neither

28)  $f(x) = x^4 - 9x^2$

A) y-axis symmetry

B) origin symmetry

C) neither

29)  $f(x) = x^3 - 4x$

A) origin symmetry

B) y-axis symmetry

C) neither

30)  $f(x) = x^3 + x^2 + 2$

A) origin symmetry

B) y-axis symmetry

C) neither

31)  $f(x) = x(3 - x^2)$

A) origin symmetry

B) y-axis symmetry

C) neither

32)  $x^5 - 18x^3 + 32x = 0$

A) origin symmetry

B) y-axis symmetry

C) neither

33)  $f(x) = x^3 + 10x^2 + 33x + 36$

A) origin symmetry

B) y-axis symmetry

C) neither

$$f(x) = (x + 1)(x - 8)(x - 1)^2$$

y-axis symmetry

B) origin symmetry

C) neither

$$f(x) = -x^2(x + 5)(x^2 - 1)$$

origin symmetry

B) y-axis symmetry

C) neither

$$f(x) = -x^3(x + 4)^2(x - 9)$$

origin symmetry

B) y-axis symmetry

C) neither

$$f(x) = (x - 2)^2(x^2 - 25)$$

origin symmetry

B) y-axis symmetry

C) neither

38)

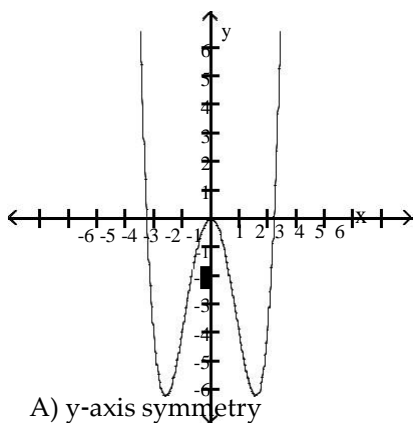

B) origin symmetry

C) neither

39)

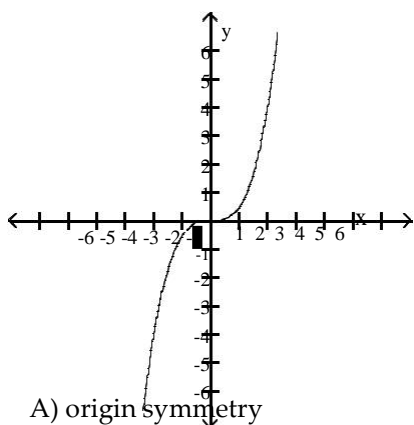

B) y-axis symmetry

C) neither

40)

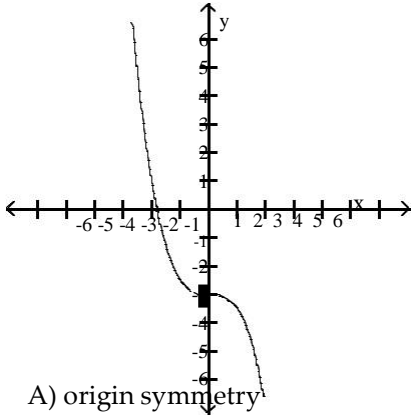

B) y-axis symmetry

C) neither

41)

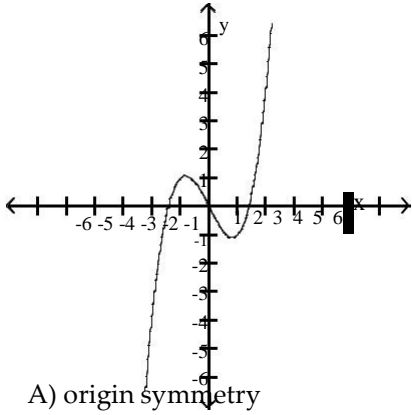

B) y-axis symmetry

C) neither

### 3 Determine End Behavior

**MULTIPLE CHOICE.** Choose the one alternative that best completes the statement or answers the question.

Use the Leading Coefficient Test to determine the end behavior of the polynomial function. Then use this end behavior to match the function with its graph.

$$f(x) = 2x^2 + 2x - 1$$

rises to the left and rises to the right

B) falls to the left and falls to the right

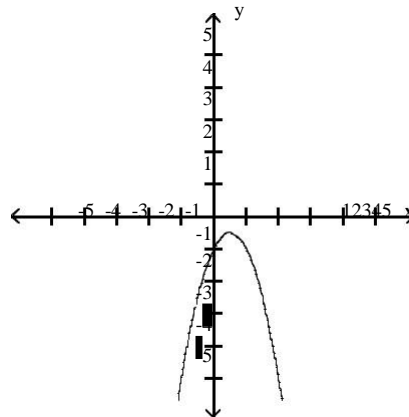
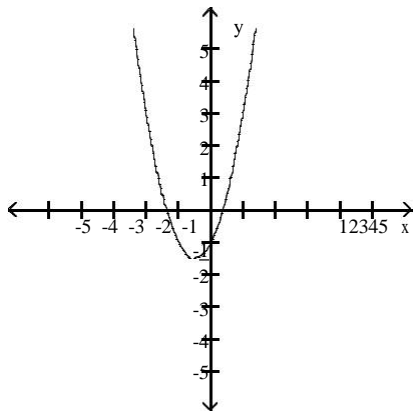

C) falls to the left and rises to the right

D) rises to the left and falls to the right

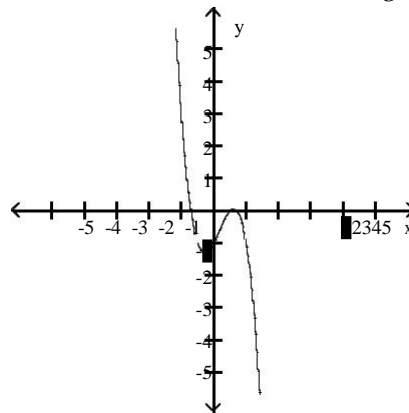
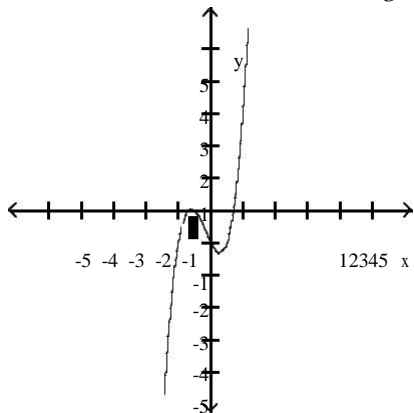

$$f(x) = -2x^2 - 2x + 1$$

falls to the left and falls to the right

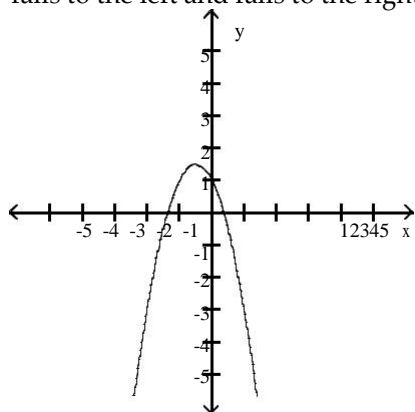

C) rises to the left and falls to the right

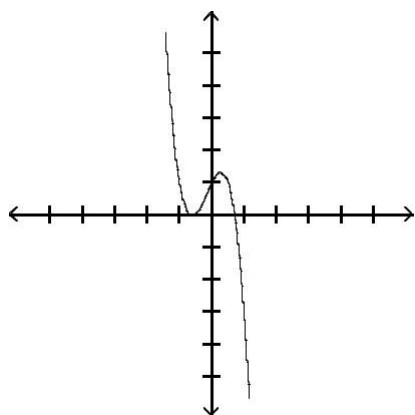

B) rises to the left and rises to the right

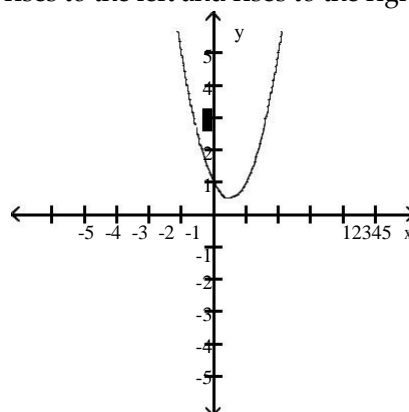

D) falls to the left and rises to the right

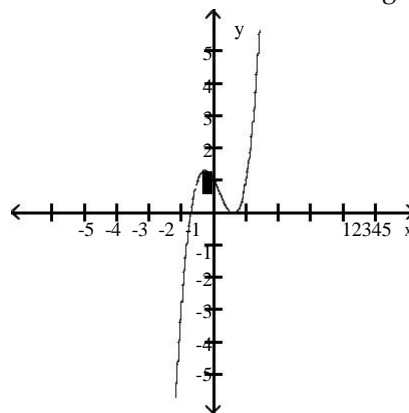



$$f(x) = 4x^3 + 2x^2 - 2x + 3$$

falls to the left and rises to the right

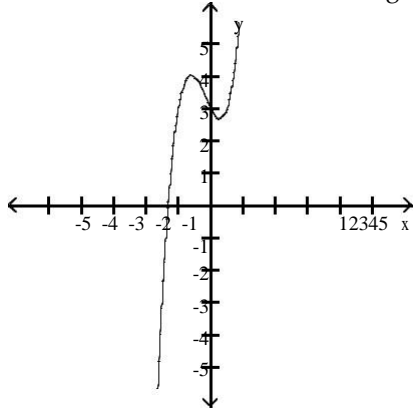

C) rises to the left and rises to the right

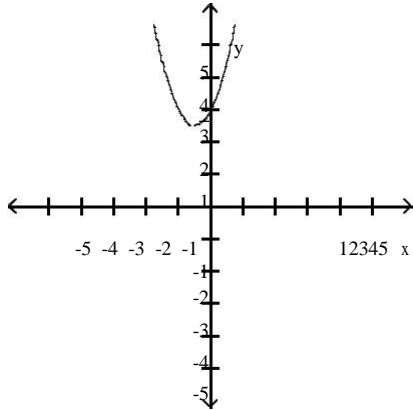

B) falls to the left and falls to the right

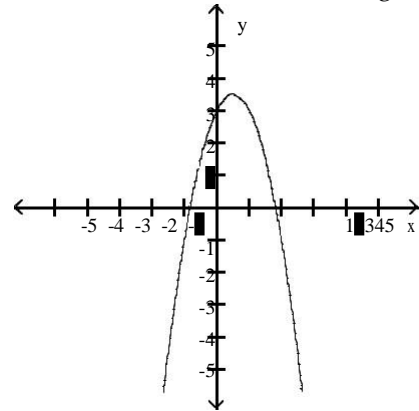

D) rises to the left and falls to the right

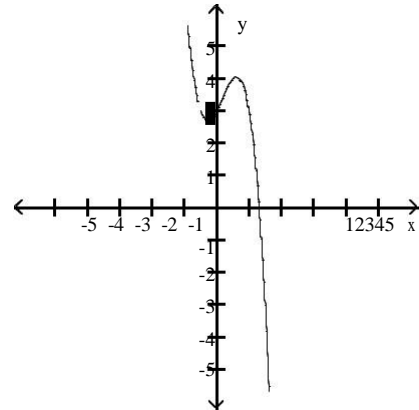

$$f(x) = -8x^3 + 3x^2 + 4x - 1$$

risers to the left and falls to the right

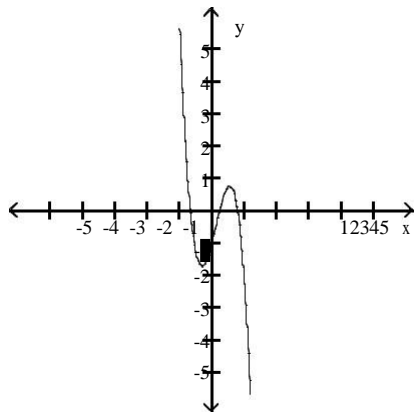

C) falls to the left and falls to the right

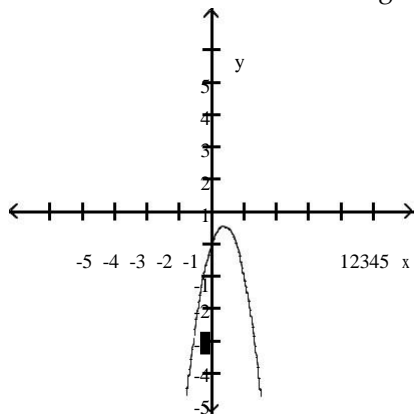

B) rises to the left and rises to the right

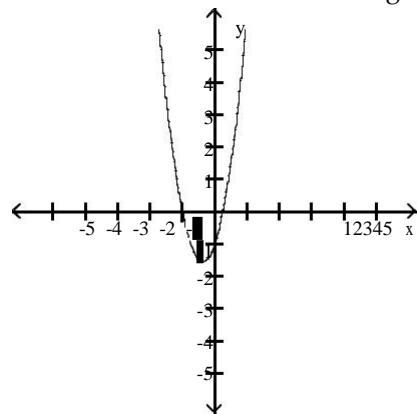

D) falls to the left and rises to the right

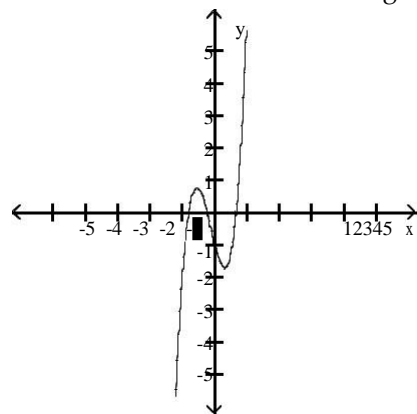

$$f(x) = 3x^4 - 2x^2$$

rises to the left and rises to the right

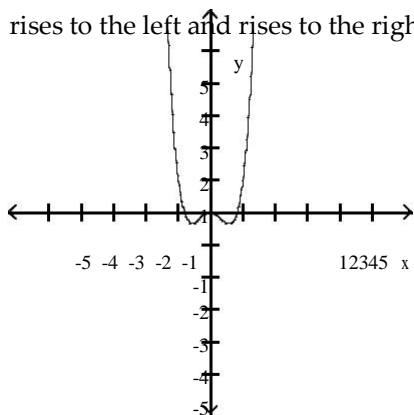

C) falls to the left and rises to the right

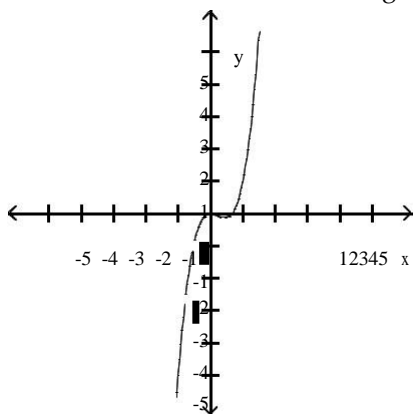

B) falls to the left and falls to the right

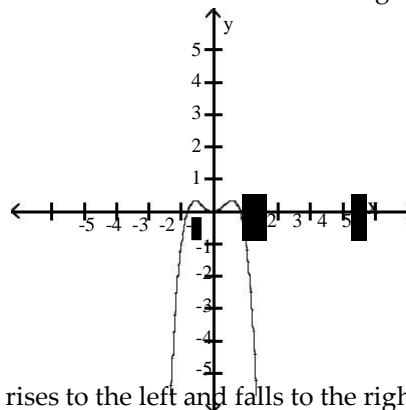

D) rises to the left and falls to the right

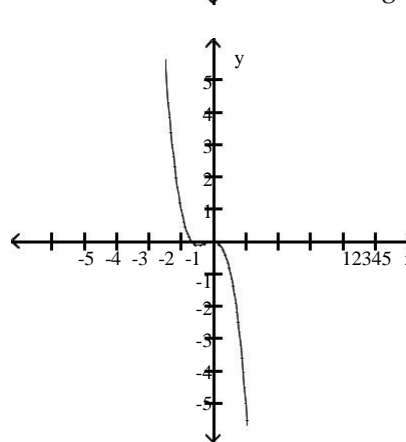

Use the Leading Coefficient Test to determine the end behavior of the polynomial function.

6)  $f(x) = 3x^4 - 3x^3 - 2x^2 + 4x - 2$

- A) rises to the left and rises to the right
- C) falls to the left and rises to the right

- B) rises to the left and falls to the right
- D) falls to the left and falls to the right

7)  $f(x) = -4x^4 + 2x^3 + 2x^2 + 5x - 3$

- A) falls to the left and falls to the right
- C) falls to the left and rises to the right

- B) rises to the left and falls to the right
- D) rises to the left and rises to the right

8)  $f(x) = 2x^3 - 5x^2 - 2x + 4$

- A) falls to the left and rises to the right
- C) falls to the left and falls to the right

- B) rises to the left and falls to the right
- D) rises to the left and rises to the right

9)  $f(x) = x^3 + 2x^2 + 5x - 1$

- A) falls to the left and rises to the right
- C) falls to the left and falls to the right

- B) rises to the left and falls to the right
- D) rises to the left and rises to the right

10)  $f(x) = -4x^3 + 2x^2 - 3x + 5$

- A) rises to the left and falls to the right
- C) falls to the left and falls to the right

- B) falls to the left and rises to the right
- D) rises to the left and rises to the right

$$11) f(x) = 3x^3 + 5x^3 - x^5$$

- A) rises to the left and falls to the right  
 C) falls to the left and falls to the right

- B) falls to the left and rises to the right  
 D) rises to the left and rises to the right

$$12) f(x) = x - 5x^2 - 2x^3$$

- A) rises to the left and falls to the right  
 C) falls to the left and falls to the right

- B) falls to the left and rises to the right  
 D) rises to the left and rises to the right

$$13) f(x) = (x - 5)(x - 4)(x - 3)^2$$

- A) rises to the left and rises to the right  
 C) rises to the left and falls to the right

- B) falls to the left and rises to the right  
 D) falls to the left and falls to the right

$$14) f(x) = (x - 5)(x - 4)(x - 2)^3$$

- A) falls to the left and rises to the right  
 C) rises to the left and falls to the right

- B) rises to the left and rises to the right  
 D) falls to the left and falls to the right

$$15) f(x) = -5(x^2 - 1)(x - 3)^2$$

- A) falls to the left and falls to the right  
 C) rises to the left and rises to the right

- B) falls to the left and rises to the right  
 D) rises to the left and falls to the right

$$16) f(x) = x^3(x - 2)(x + 3)^2$$

- A) rises to the left and rises to the right  
 C) rises to the left and falls to the right

- B) falls to the left and rises to the right  
 D) falls to the left and falls to the right

$$17) f(x) = -x^2(x - 2)(x + 3)$$

- A) falls to the left and falls to the right  
 C) rises to the left and falls to the right

- B) falls to the left and rises to the right  
 D) rises to the left and rises to the right

$$18) f(x) = -6x^3(x - 3)(x + 2)^2$$

- A) falls to the left and falls to the right  
 C) rises to the left and falls to the right

- B) falls to the left and rises to the right  
 D) rises to the left and rises to the right

**Solve the problem.**

A herd of deer is introduced to a wildlife refuge. The number of deer,  $N(t)$ , after  $t$  years is described by the polynomial function  $N(t) = -t^4 + 25t + 100$ . Use the Leading Coefficient Test to determine the graph's end behavior. What does this mean about what will eventually happen to the deer population?

The deer population in the refuge will die out.

The deer population in the refuge will grow out of control.

The deer population in the refuge will reach a constant amount greater than 0.

The deer population in the refuge will be displaced by "oil" wells.

The following table shows the number of fires in a county for the years 1994-1998, where 1 represents 1994, 2 represents 1995, and so on.

Year, x	Fires, T
1994, 1	3452
1995, 2	3497.6
1996, 3	3553.38
1997, 4	3597.92
1998, 5	3653.8

This data can be approximated using the third-degree polynomial

$$T(x) = -0.57x^3 + 0.51x^2 + 62.06x + 3390.$$

Use this function to predict the number of fires in 2005. Round to the nearest whole number.

- A) 3223                                      B) 3209                                      C) -155                                      D) 2478

The following table shows the number of fires in a county for the years 1994-1998, where 1 represents 1994, 2 represents 1995, and so on.

Year, x	Fires, T
1994, 1	2663.9
1995, 2	2736.04
1996, 3	2771.48
1997, 4	2819.28
1998, 5	2878.5

This data can be approximated using the third-degree polynomial

$$T(x) = -0.49x^3 + 0.59x^2 + 62.80x + 2601.$$

Use the Leading Coefficient Test to determine the end behavior to the right for the graph of T. Will this function be useful in modeling the number of fires over an extended period of time? Explain your answer.

The graph of T decreases without bound to the right. This means that as x increases, the values of T will become more and more negative and the function will no longer model the number of fires.

The graph of T increases without bound to the right. This means that as x increases, the values of T will become large and positive and, since the values of T will become so large, the function will no longer model the number of fires.

The graph of T approaches zero for large values of x. This means that T will not be useful in modeling the number of fires over an extended period.

The graph of T decreases without bound to the right. Since the number of larceny thefts will eventually decrease, the function T will be useful in modeling the number of fires over an extended period of time.

#### 4 Use Factoring to Find Zeros of Polynomial Functions

**MULTIPLE CHOICE.** Choose the one alternative that best completes the statement or answers the question.

Find the zeros of the polynomial function.

$$f(x) = x^3 + x^2 - 20x$$

$$x = 0, x = -5, x = 4$$

$$x = 3, x = 4$$

$$x = -5, x = 4$$

$$x = 0, x = 3, x = 4$$

$$2) f(x) = x^3 + 2x^2 - x - 2$$

A)  $x = -1, x = 1, x = -2$

C)  $x = -2, x = 2$

B)  $x = 1, x = -2, x = 2$

D)  $x = 4$

$$3) f(x) = x^3 - 8x^2 + 16x$$

A)  $x = 0, x = 4$

B)  $x = 0, x = -4$

C)  $x = 1, x = 4$

D)  $x = 0, x = -4, x = 4$

$$4) f(x) = x^3 + 5x^2 - 9x - 45$$

A)  $x = -5, x = -3, x = 3$

C)  $x = -3, x = 3$

B)  $x = 5, x = -3, x = 3$

D)  $x = -5, x = 9$

$$5) f(x) = 5(x + 5)(x - 4)^2$$

A)  $x = -5, x = 4,$

B)  $x = 5, x = 2$

C)  $x = -5, x = 2$

D)  $x = 5, x = -4, x = 2$

## 5 Identify Zeros and Their Multiplicities

**MULTIPLE CHOICE.** Choose the one alternative that best completes the statement or answers the question.

**Find the zeros for the polynomial function and give the multiplicity for each zero. State whether the graph crosses the x-axis or touches the x-axis and turns around, at each zero.**

$$f(x) = 5(x + 6)(x - 6)^4$$

-6, multiplicity 1, crosses x-axis; 6, multiplicity 4, touches x-axis and turns around

6, multiplicity 1, crosses x-axis; -6, multiplicity 4, touches x-axis and turns around

-6, multiplicity 1, touches x-axis and turns around; 6, multiplicity 4, crosses x-axis

6, multiplicity 1, touches x-axis and turns around; -6, multiplicity 4, crosses x-axis

$$f(x) = 4(x - 6)(x - 3)^3$$

6, multiplicity 1, crosses x-axis; 3, multiplicity 3, crosses x-axis

-6, multiplicity 1, crosses x-axis; -3, multiplicity 3, crosses x-axis

6, multiplicity 1, crosses x-axis; 3, multiplicity 3, touches x-axis and turns around

-6, multiplicity 1, touches x-axis; -3, multiplicity 3, touches x-axis and turns around

$$f(x) = -3(x + 4)(x - 2)^3$$

-4, multiplicity 1, crosses x-axis; 2, multiplicity 3, crosses x-axis

4, multiplicity 1, crosses x-axis; -2, multiplicity 3, crosses x-axis

-4, multiplicity 1, touches the x-axis and turns around; 2, multiplicity 3, touches x-axis and turns around

4, multiplicity 1, touches the x-axis and turns around; -2, multiplicity 3, touches x-axis and turns around

$$f(x) = 2(x^2 + 4)(x - 2)^2$$

2, multiplicity 2, touches the x-axis and turns around

-4, multiplicity 1, crosses the x-axis; 2, multiplicity 2, touches the x-axis and turns around.

-4, multiplicity 1, crosses the x-axis; 2, multiplicity 2, crosses the x-axis

2, multiplicity 2, crosses the x-axis

$$f(x) = \frac{1}{x^4}(x^2 - 3)(x + 2)^4$$

- 0, multiplicity 4, touches x-axis and turns around;
- 2, multiplicity 1, crosses x-axis;
- $\sqrt{3}$ , multiplicity 1, crosses x-axis;
- $\sqrt{3}$ , multiplicity 1, crosses x-axis
- 0, multiplicity 4, crosses x-axis;
- 2, multiplicity 1, touches x-axis and turns around;
- $\sqrt{3}$ , multiplicity 1, touches x-axis and turns around;
- $\sqrt{3}$ , multiplicity 1, touches x-axis and turns around
- 0, multiplicity 4, touches x-axis and turns around;
- 2, multiplicity 1, crosses x-axis
- 0, multiplicity 4, touches x-axis and turns around;
- 2, multiplicity 1, crosses x-axis
- 3, multiplicity 2, touches x-axis and turns around

$$f(x) = \left(x + \frac{1}{5}\right)^4(x + 5)^3$$

- $-\frac{1}{5}$ , multiplicity 4, touches the x-axis and turns around; 5
- 5, multiplicity 3, crosses the x-axis.
- $-\frac{1}{5}$ , multiplicity 4, crosses the x-axis; 5
- 5, multiplicity 3, touches the x-axis and turns around
- $\frac{1}{5}$ , multiplicity 4, touches the x-axis and turns around; 5
- 5, multiplicity 3, crosses the x-axis.
- $\frac{1}{5}$ , multiplicity 4, crosses the x-axis;
- 5
- 5, multiplicity 3, touches the x-axis and turns around

$$f(x) = \left(x + \frac{1}{2}\right)^2(x^2 + 1)^5$$

- $-\frac{1}{2}$ , multiplicity 2, touches the x-axis and turns around. 2
- $-\frac{1}{2}$ , multiplicity 2, touches the x-axis and turns around; 2
- 1, multiplicity 5, crosses the x-axis
- $\frac{1}{2}$ , multiplicity 2, touches the x-axis and turns around; 2
- 1, multiplicity 5, crosses the x-axis
- $-\frac{1}{2}$ , multiplicity 2, crosses the x-axis. 2

$$f(x) = x^3 + x^2 - 12x$$

- 0, multiplicity 1, crosses the x-axis
- 4, multiplicity 1, crosses the x-axis
- 3, multiplicity 1, crosses the x-axis
- 4, multiplicity 2, touches the x-axis and turns around
- 3, multiplicity 1, crosses the x-axis
- 0, multiplicity 1, crosses the x-axis
- 4, multiplicity 1, crosses the x-axis
- 3, multiplicity 1, crosses the x-axis
- 0, multiplicity 1, touches the x-axis and turns around;
- 4, multiplicity 1, touches the x-axis and turns around;
- 3, multiplicity 1, touches the x-axis and turns around

$$f(x) = x^3 + 8x^2 + 20x + 16$$

- 2, multiplicity 2, touches the x-axis and turns around;
- 4, multiplicity 1, crosses the x-axis.
- 2, multiplicity 2, crosses the x-axis;
- 4, multiplicity 1, touches the x-axis and turns around
- 2, multiplicity 1, crosses the x-axis;
- 2, multiplicity 1, crosses the x-axis;
- 4, multiplicity 1, crosses the x-axis.
- 2, multiplicity 1, crosses the x-axis;
- 2, multiplicity 2, touches the x-axis and turns around;
- 4, multiplicity 1, crosses the x-axis.

$$f(x) = x^3 + 7x^2 - x - 7$$

- 1, multiplicity 1, crosses the x-axis;
- 1, multiplicity 1, crosses the x-axis;
- 7, multiplicity 1, crosses the x-axis.
- 7, multiplicity 1, crosses the x-axis;
- 1, multiplicity 1, crosses the x-axis;
- 7, multiplicity 1, crosses the x-axis.
- 1, multiplicity 2, touches the x-axis and turns around;
- 7, multiplicity 1, crosses the x-axis.
- 1, multiplicity 1, touches the x-axis and turns around; 1,
- multiplicity 1, touches the x-axis and turns around;
- 7, multiplicity 1, touches the x-axis and turns around

**Write the equation of a polynomial function with the given characteristics. Use a leading coefficient of 1 or -1 and make the degree of the function as small as possible.**

Crosses the x-axis at -1, 0, and 4; lies above the x-axis between -1 and 0; lies below the x-axis between 0 and 4.

A)  $f(x) = x^3 - 3x^2 - 4x$

B)  $f(x) = x^3 + 3x^2 - 4x$

C)  $f(x) = -x^3 + 3x^2 + 4x$

D)  $f(x) = -x^3 - 3x^2 + 4x$

Crosses the x-axis at -3, 0, and 1; lies below the x-axis between -3 and 0; lies above the x-axis between 0 and 1.

A)  $f(x) = -x^3 - 2x^2 + 3x$

B)  $f(x) = -x^3 + 2x^2 + 3x$

C)  $f(x) = x^3 + 2x^2 - 3x$

D)  $f(x) = x^3 - 2x^2 - 3x$



13) Touches the x-axis at 0 and crosses the x-axis at 2; lies below the x-axis between 0 and 2.

A)  $f(x) = x^3 - 2x^2$       B)  $f(x) = x^3 + 2x^2$       C)  $f(x) = -x^3 + 2x^2$       D)  $f(x) = -x^3 - 2x^2$

14) Touches the x-axis at 0 and crosses the x-axis at 2; lies above the x-axis between 0 and 2.

A)  $f(x) = -x^3 + 2x^2$       B)  $f(x) = x^3 + 2x^2$       C)  $f(x) = x^3 - 2x^2$       D)  $f(x) = -x^3 - 2x^2$

## 6 Use the Intermediate Value Theorem

**MULTIPLE CHOICE.** Choose the one alternative that best completes the statement or answers the question.

Use the Intermediate Value Theorem to determine whether the polynomial function has a real zero between the given integers.

1)  $f(x) = 6x^3 + 7x^2 + 8x + 10$ ; between -2 and -1

A)  $f(-2) = -26$  and  $f(-1) = 3$ ; yes

C)  $f(-2) = -26$  and  $f(-1) = -3$ ; no

B)  $f(-2) = 26$  and  $f(-1) = 3$ ; no

D)  $f(-2) = 26$  and  $f(-1) = -3$ ; yes

2)  $f(x) = 4x^5 - 9x^3 - 6x^2 - 6$ ; between 1 and 2

A)  $f(1) = -17$  and  $f(2) = 26$ ; yes

C)  $f(1) = -17$  and  $f(2) = -26$ ; no

B)  $f(1) = 17$  and  $f(2) = 26$ ; no

D)  $f(1) = 17$  and  $f(2) = -26$ ; yes

3)  $f(x) = 3x^4 - 5x^2 - 8$ ; between 1 and 2

A)  $f(1) = -10$  and  $f(2) = 20$ ; yes

C)  $f(1) = -10$  and  $f(2) = -20$ ; no

B)  $f(1) = 10$  and  $f(2) = 21$ ; no

D)  $f(1) = 10$  and  $f(2) = -20$ ; yes

4)  $f(x) = -2x^4 - 4x^3 + 8x + 2$ ; between 1 and 2

A)  $f(1) = 4$  and  $f(2) = -46$ ; yes

C)  $f(1) = -4$  and  $f(2) = -46$ ; no

B)  $f(1) = 4$  and  $f(2) = 46$ ; no

D)  $f(1) = -4$  and  $f(2) = 46$ ; yes

5)  $f(x) = 9x^3 - 7x - 5$ ; between 1 and 2

A)  $f(1) = -3$  and  $f(2) = 53$ ; yes

C)  $f(1) = 3$  and  $f(2) = 53$ ; no

B)  $f(1) = -3$  and  $f(2) = -53$ ; no

D)  $f(1) = 3$  and  $f(2) = -53$ ; yes

## 7 Understand the Relationship Between Degree and Turning Points

**MULTIPLE CHOICE.** Choose the one alternative that best completes the statement or answers the question.

Determine the maximum possible number of turning points for the graph of the function.

1)  $f(x) = -x^2 + 6x + 5$

A) 1

B) 2

C) 0

D) 3

2)  $f(x) = 6x^8 - 3x^7 - 7x - 23$

A) 7

B) 0

C) 6

D) 8

3)  $f(x) = x^6 + 8x^7$

A) 6

B) 7

C) 8

D) 1

$g(x) = -\frac{5}{x} + 14$

A) 0

B) 2

C) 1

D) 3

5)  $f(x) = (x - 7)(x + 7)(6x - 1)$

A) 2

B) 6

C) 3

D) 0

6)  $f(x) = x^2(x^2 - 3)(3x - 1)$

A) 4

B) 5

C) 12

D) 2

7)  $f(x) = (2x + 5)^4(x^4 - 5)(x - 3)$

A) 8

B) 9

C) 18

D) 4

8)  $f(x) = (x - 5)(x + 3)(x - 3)(x + 1)$

A) 3

B) 4

C) 0

D) 1

**Solve.**

9) Suppose that a polynomial function is used to model the data shown in the graph below.

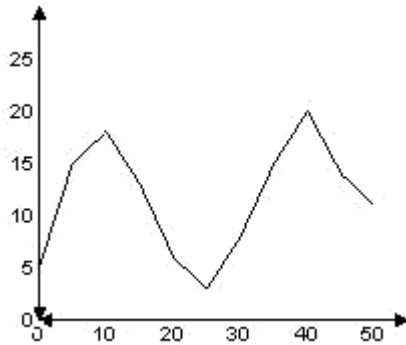

For what intervals is the function increasing?

A) 0 through 10 and 25 through 40

B) 0 through 40

C) 0 through 10 and 20 through 50

D) 10 through 25 and 40 through 50

10) Suppose that a polynomial function is used to model the data shown in the graph below.

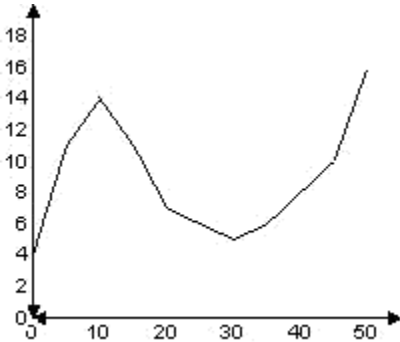

For what intervals is the function increasing?

A) 0 through 10 and 30 through 50

B) 0 through 50

C) 0 through 20 and 30 through 50

D) 0 through 10 and 40 through 50

11) Suppose that a polynomial function is used to model the data shown in the graph below.

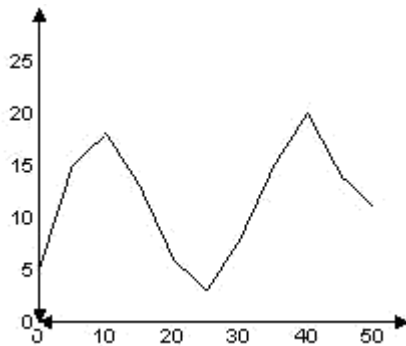

For what intervals is the function decreasing?

- A) 10 through 25 and 40 through 50
- B) 10 through 50
- C) 10 through 25 and 40 through 45
- D) 0 through 10 and 25 through 40

12) Suppose that a polynomial function is used to model the data shown in the graph below.

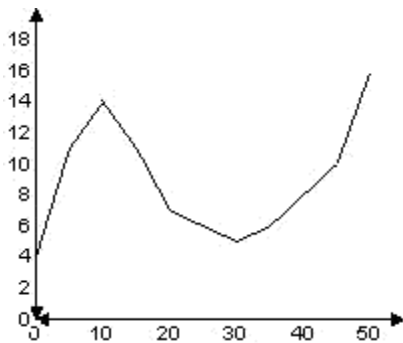

For what intervals is the function decreasing?

- A) 10 through 30
- B) 0 through 30
- C) 10 through 20 and 30 through 50
- D) 0 through 10 and 30 through 50

13) Suppose that a polynomial function is used to model the data shown in the graph below.

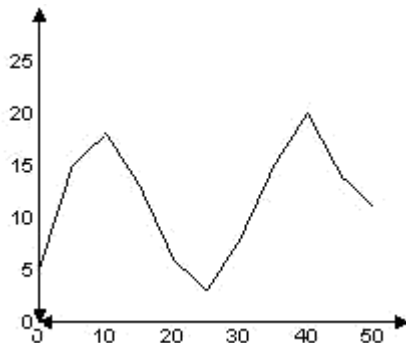

Determine the degree of the polynomial function of best fit and the sign of the leading coefficient.

- A) Degree 4; negative leading coefficient.
- B) Degree 5; positive leading coefficient.
- C) Degree 5; negative leading coefficient.
- D) Degree 4; positive leading coefficient.

14) Suppose that a polynomial function is used to model the data shown in the graph below.

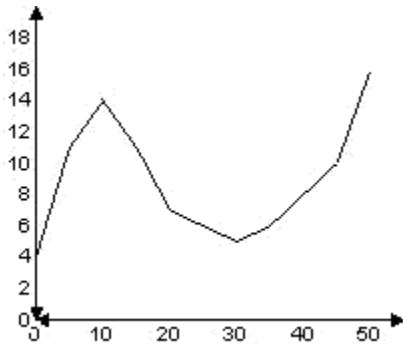

Determine the degree of the polynomial function of best fit and the sign of the leading coefficient.

- A) Degree 3; positive leading coefficient.                      B) Degree 4; negative leading coefficient.  
 C) Degree 3; negative leading coefficient.                      D) Degree 4; positive leading coefficient.

15) The profits (in millions) for a company for 8 years were as follows:

Year, $x$	Profits, $P$
1993, 1	1.1
1994, 2	1.7
1995, 3	2.0
1996, 4	1.4
1997, 5	1.3
1998, 6	1.5
1999, 7	1.8
2000, 8	2.1

Which of the following polynomials is the best model for this data?

- A)  $P(x) = 0.05x^2 - 0.8x + 6$                                       B)  $P(x) = -0.08x^3 + 7x^2 + 1.3x - 0.18$   
 C)  $P(x) = 0.03x^3 - 0.3x^2 + 1.3x + 0.17$                       D)  $P(x) = -0.03x^4 - 0.3x^2 + 1.3x + 0.17$

## 8 Graph Polynomial Functions

**MULTIPLE CHOICE.** Choose the one alternative that best completes the statement or answers the question.

Graph the polynomial function.

$$1) f(x) = x^4 - 4x^2$$

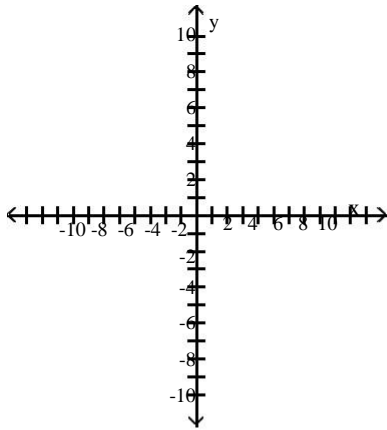

A)

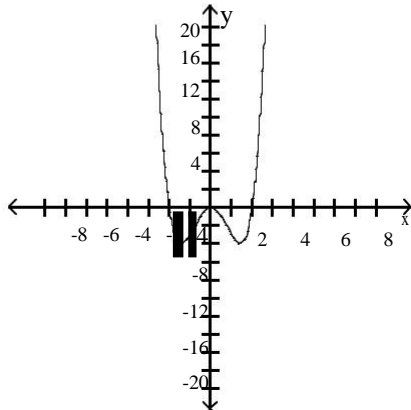

C)

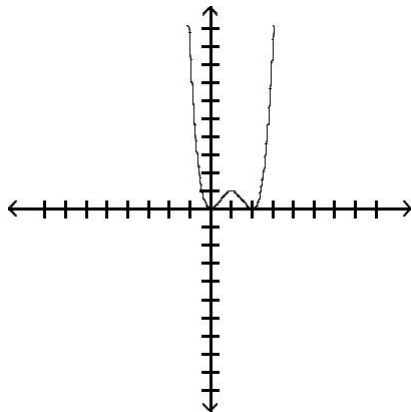

B)

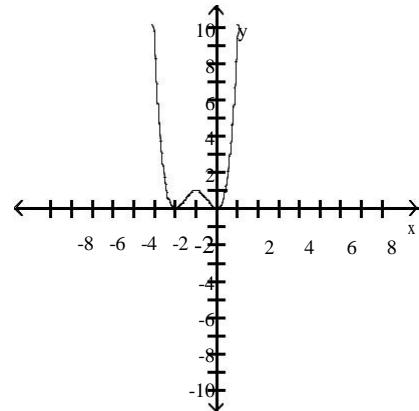

D)

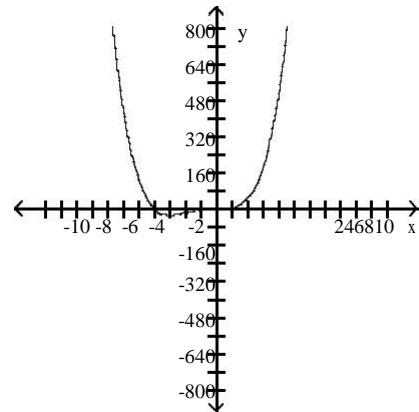

2)  $f(x) = 4x^2 - x^3$

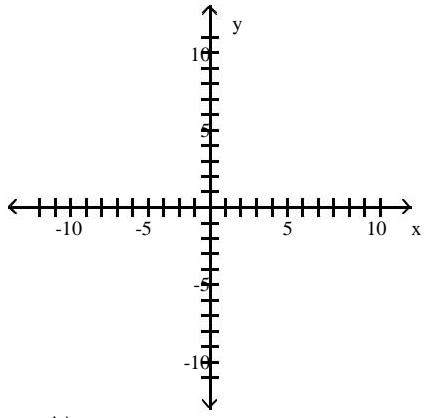

A)

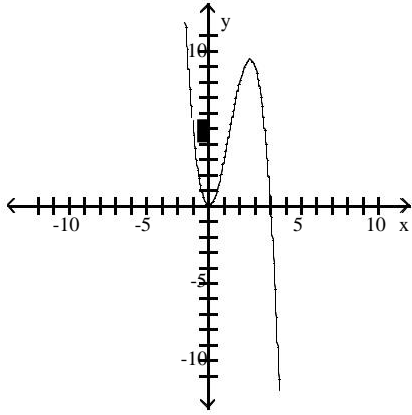

B)

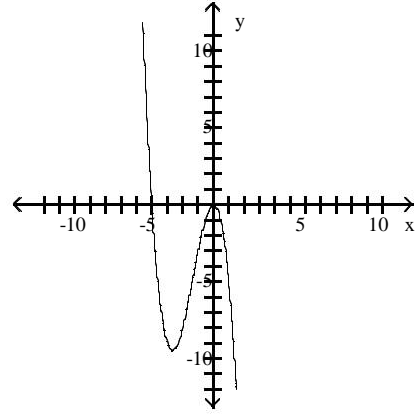

C)

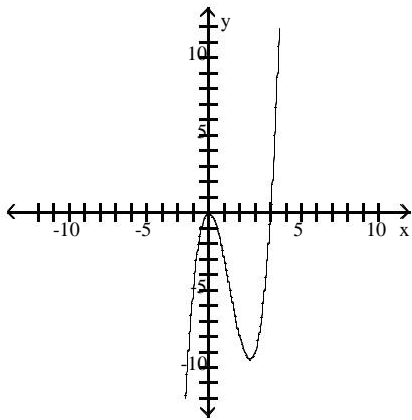

D)

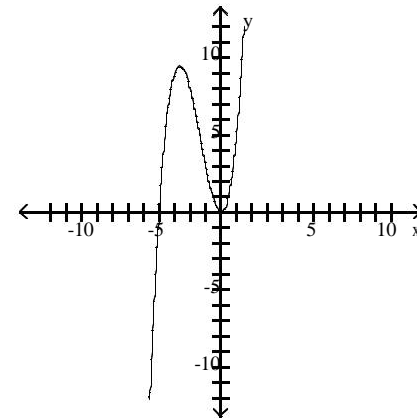

$$f(x) = \frac{1}{3}x^3 - 1$$

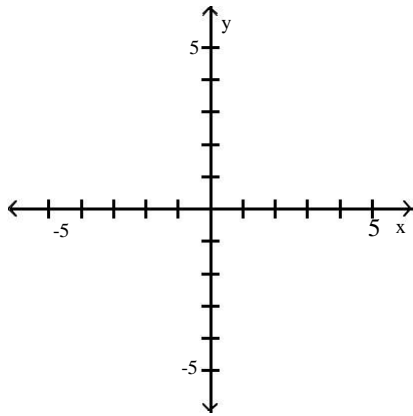

A)

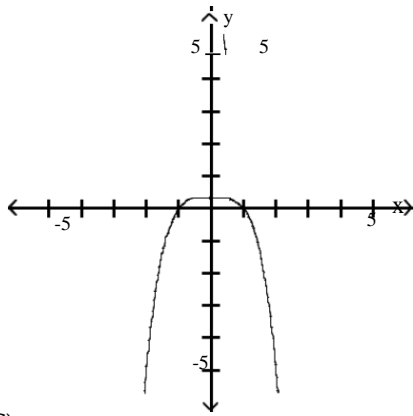

C)

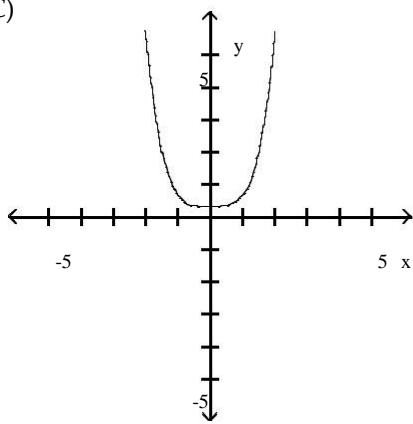

B)

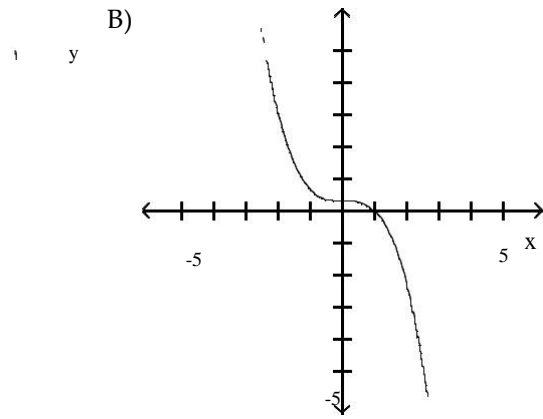

D)

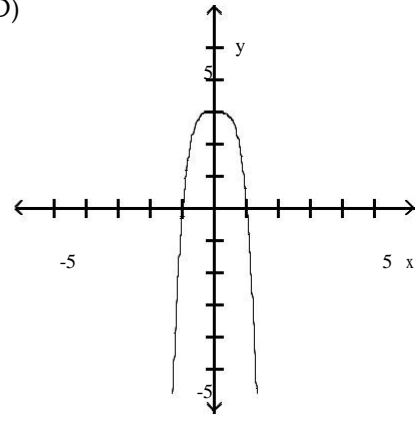



4)  $f(x) = x^3 + 9x^2 - x - 9$

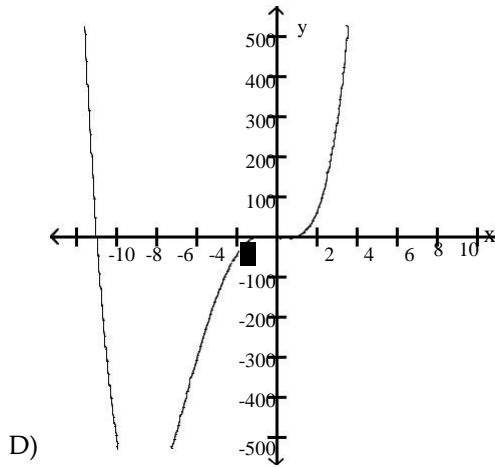
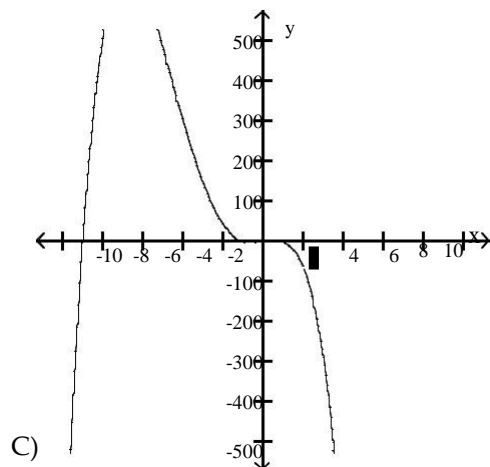
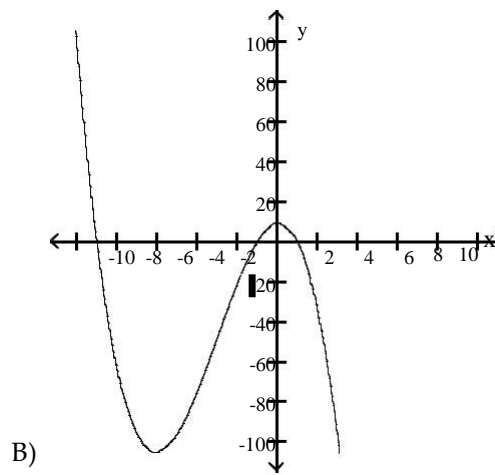
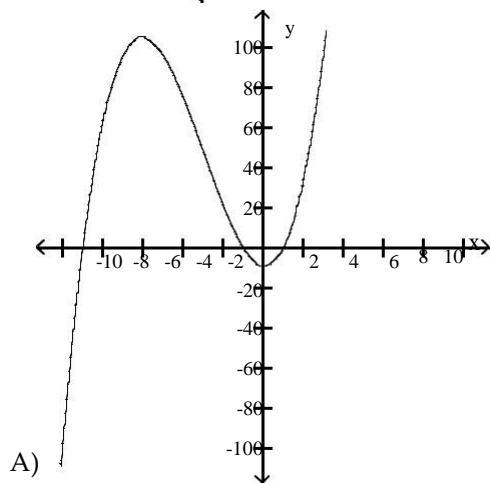
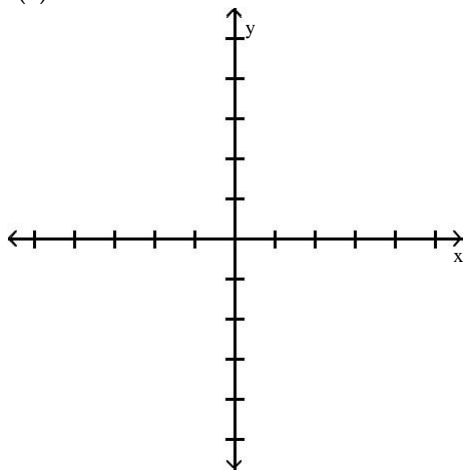

$$5) f(x) = x^3 - 4x^2 + x + 6$$

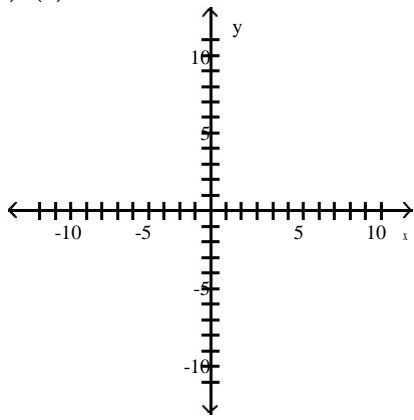

A)

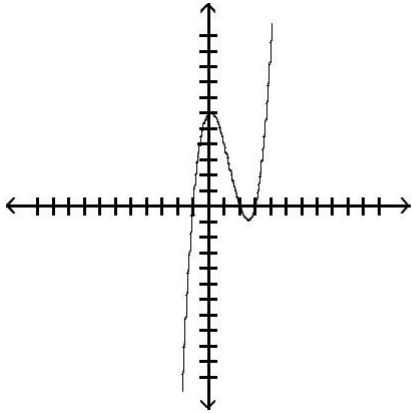

B)

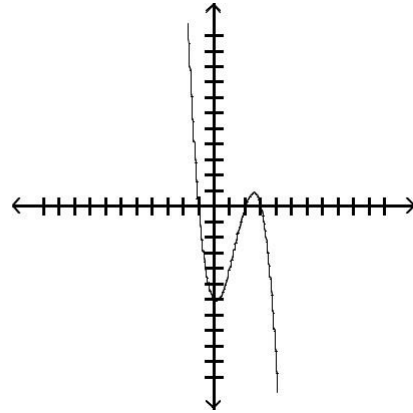

C)

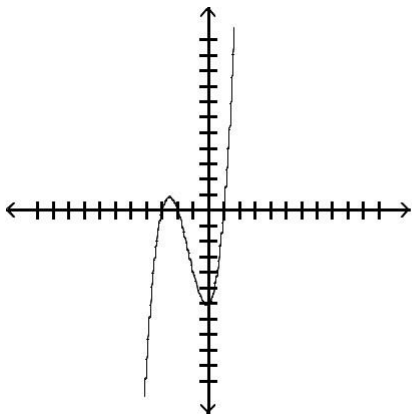

D)

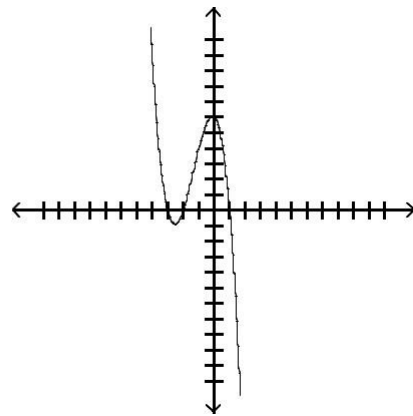

$$6) f(x) = 6x - x^3 - x^5$$

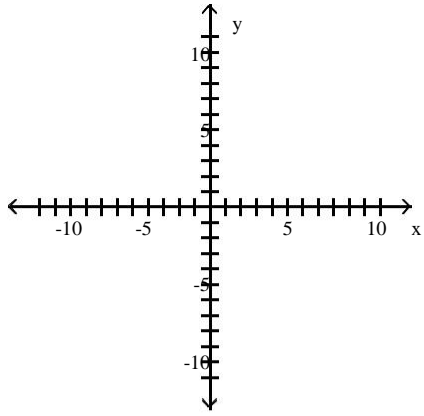

A)

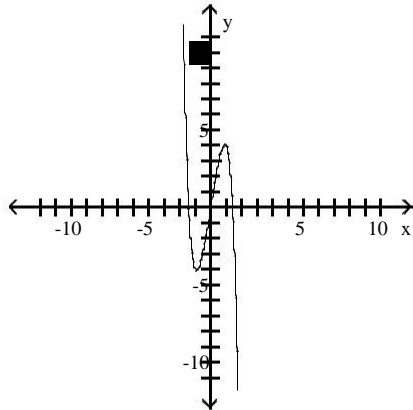

B)

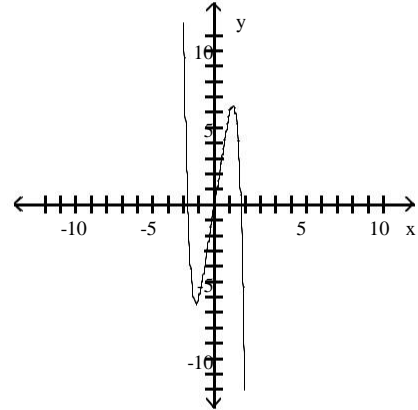

C)

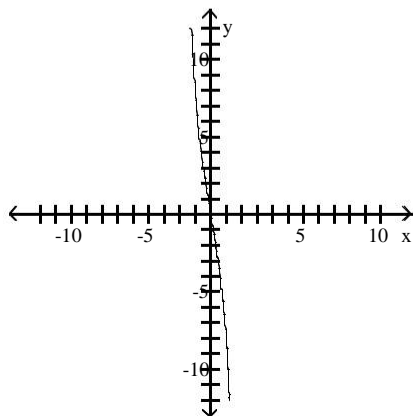

D)

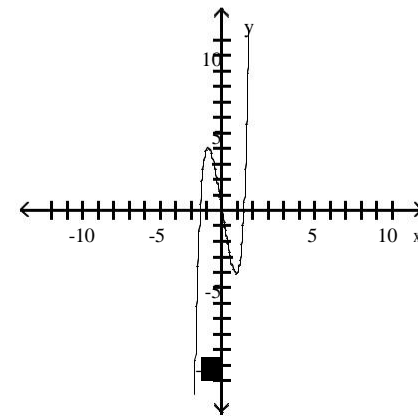

7)  $f(x) = 6x^4 + 9x^3$

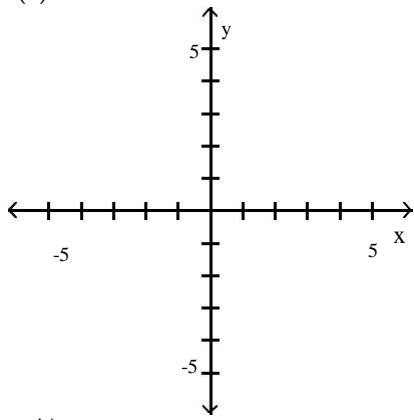

A)

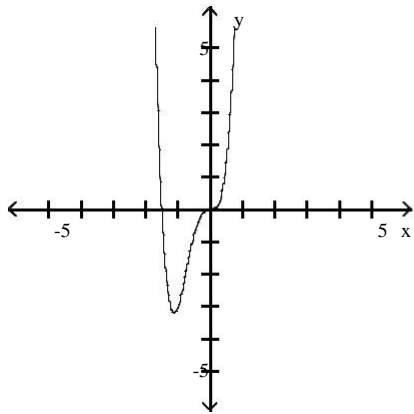

B)

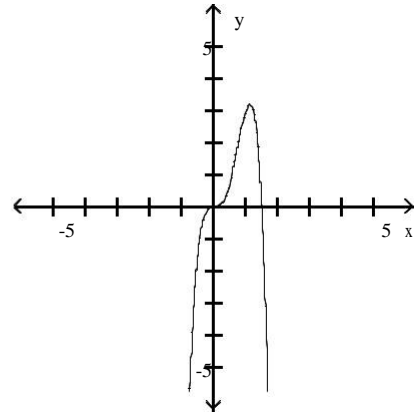

C)

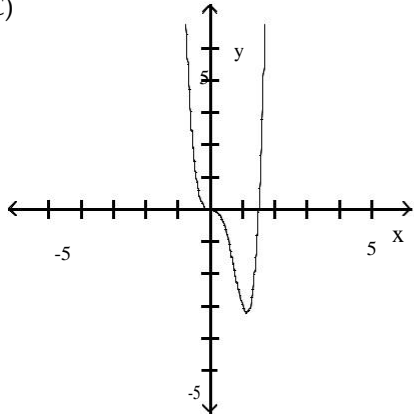

D)

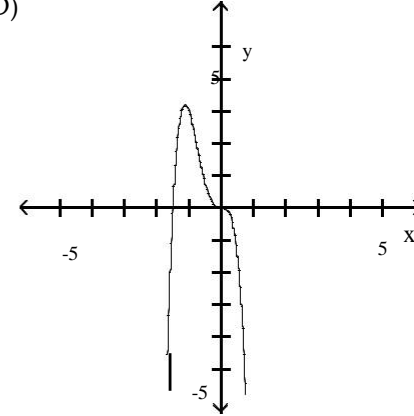

8)  $f(x) = 6x^3 - 5x - x^5$

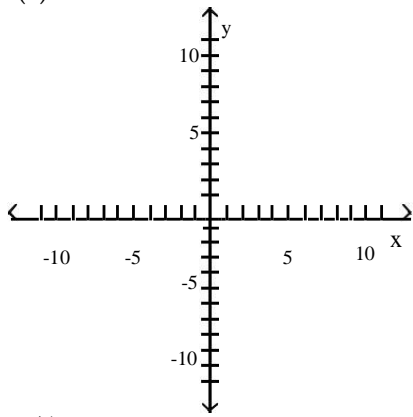

A)

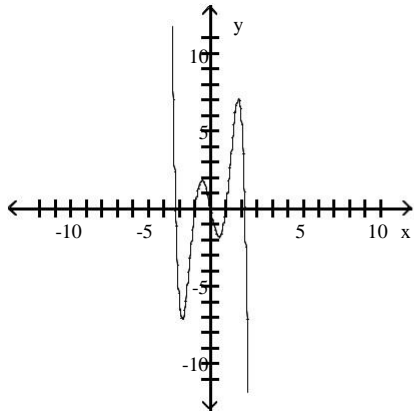

C)

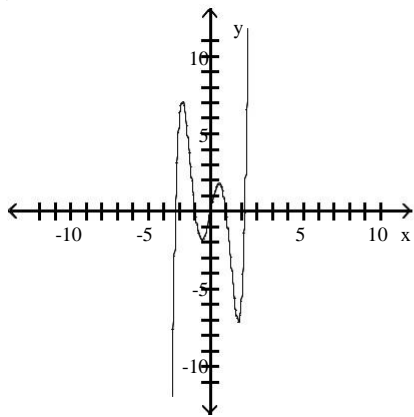

B)

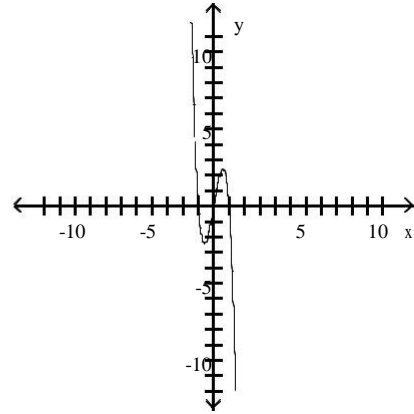

D)

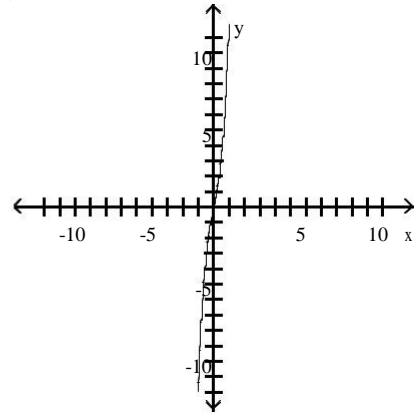

9)  $f(x) = x^4 - 8x^3 + 16x^2$

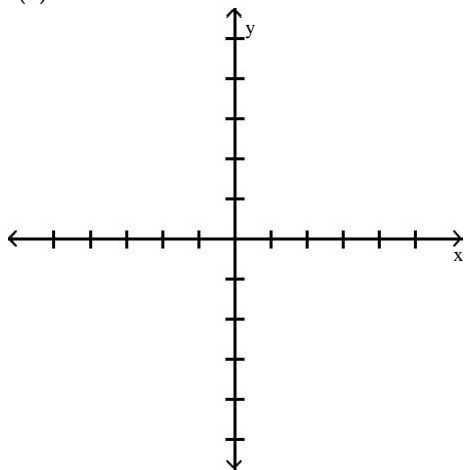

A)

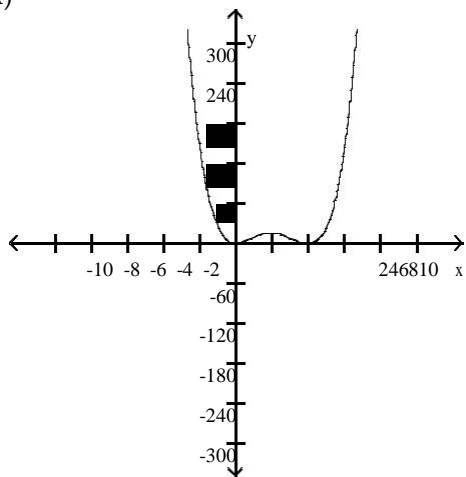

B)

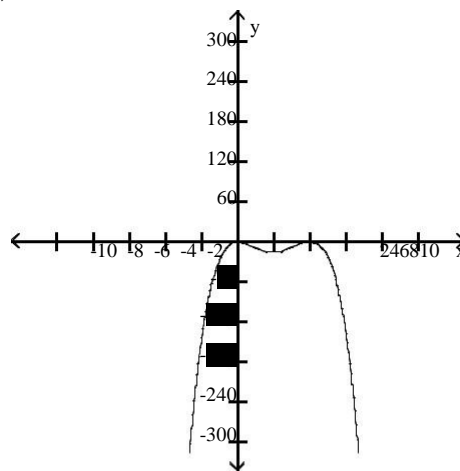

C)

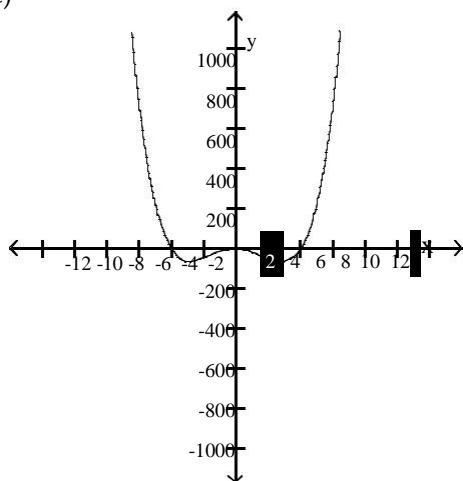

D)

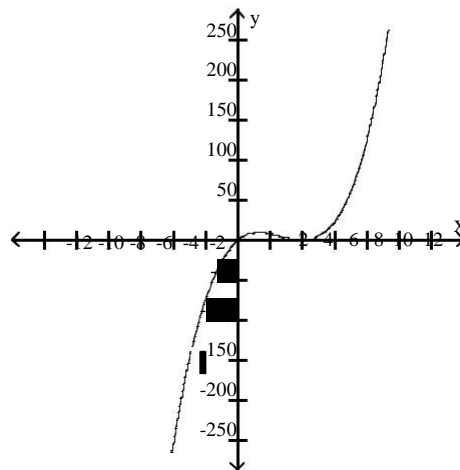

10)  $f(x) = x^5 - 6x^3 - 27x$

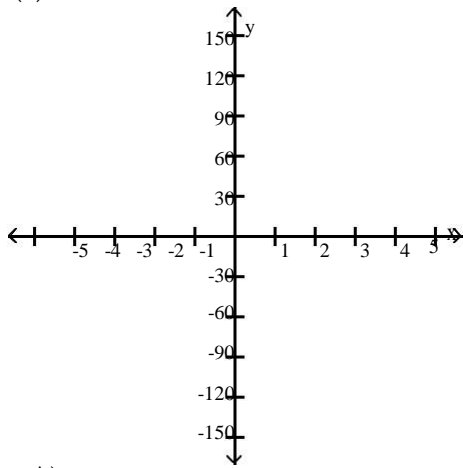

A)

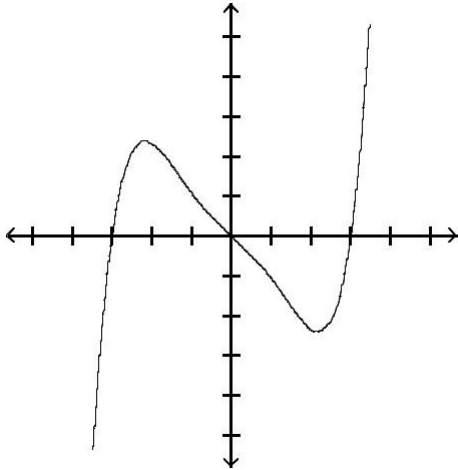

B)

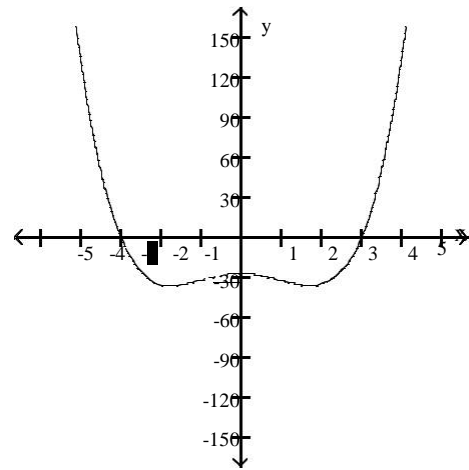

C)

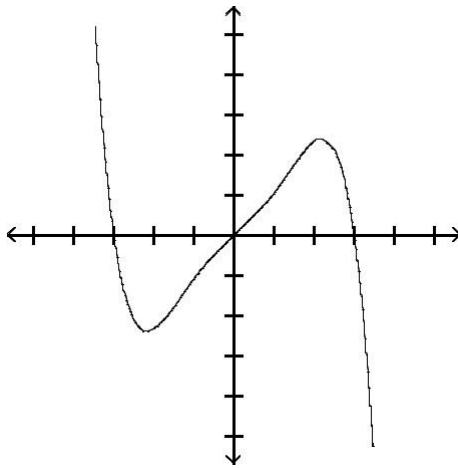

D)

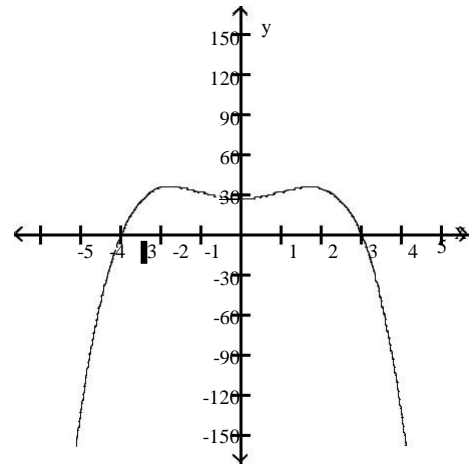

11)  $f(x) = x^4 - 2x^3 - x^2 + 2$

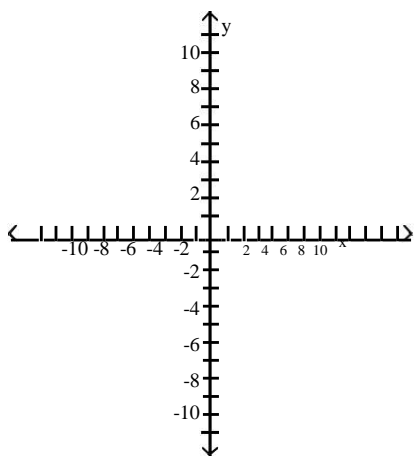

A)

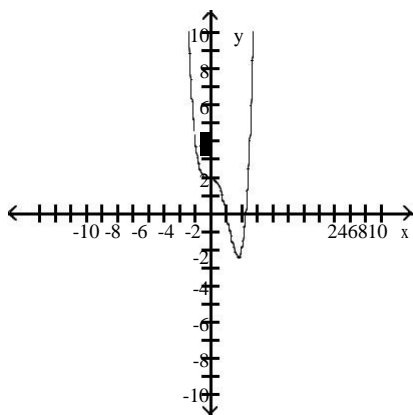

B)

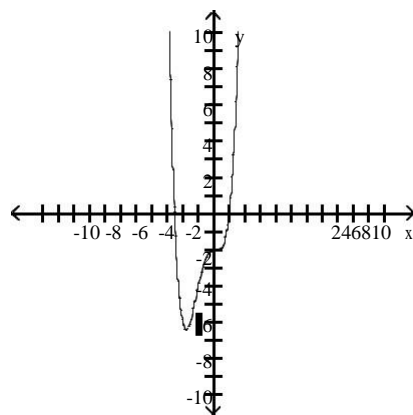

C)

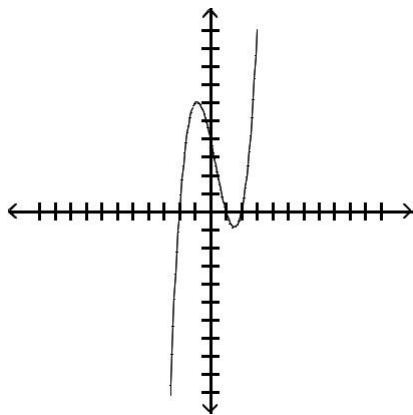

D)

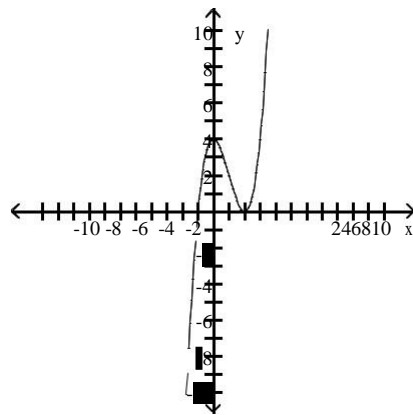



12)  $f(x) = x^4 + 4x^3 + 4x^2$

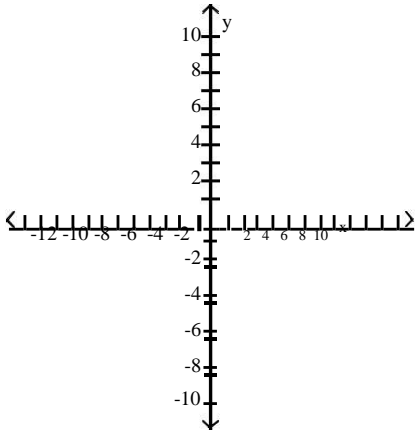

A)

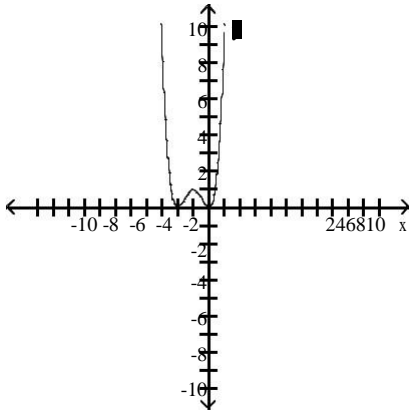

B)

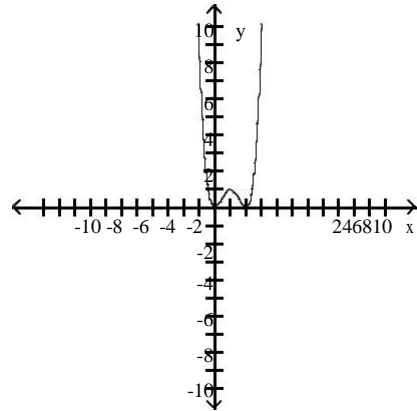

C)

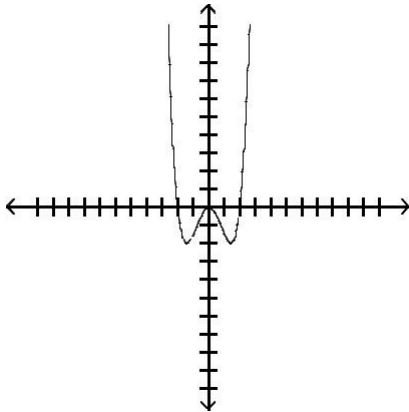

D)

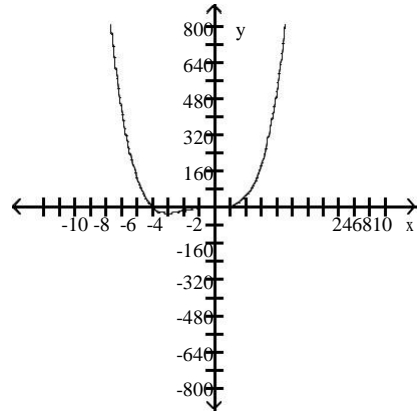

13)  $f(x) = -2x(x + 2)^2$

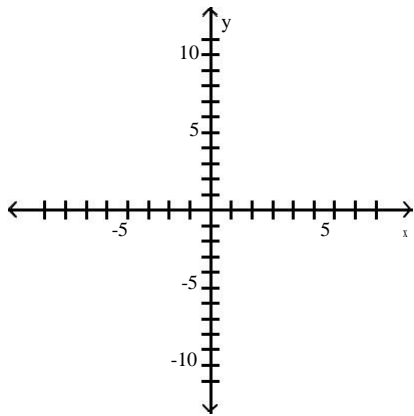

A)

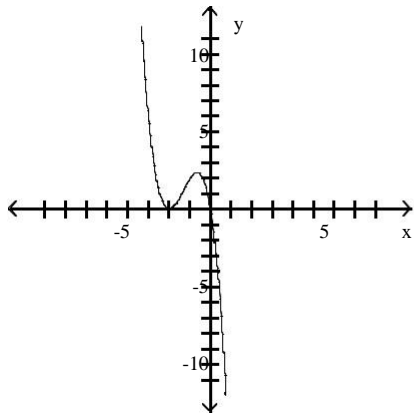

B)

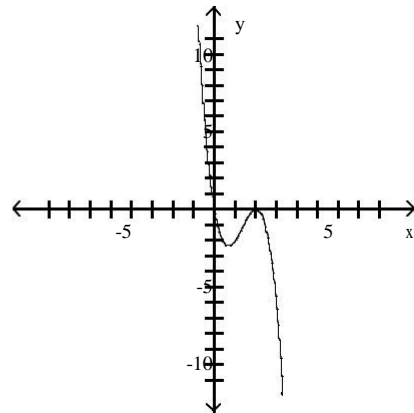

C)

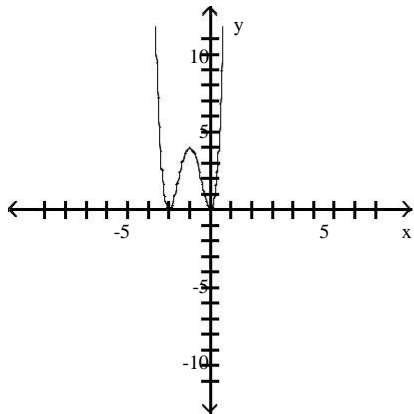

D)

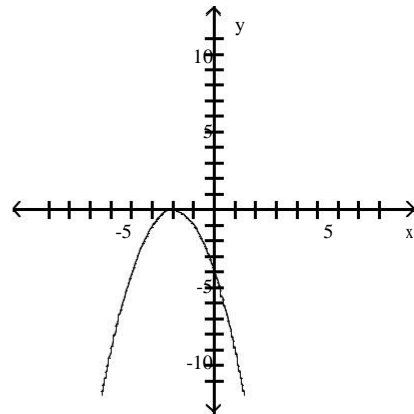

14)  $f(x) = x(x - 1)(x + 1)$

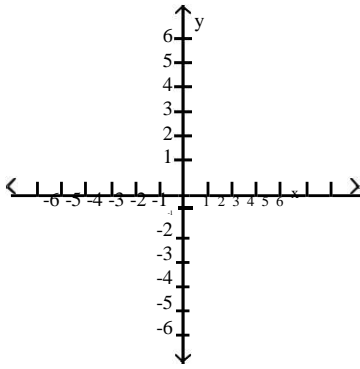

A)

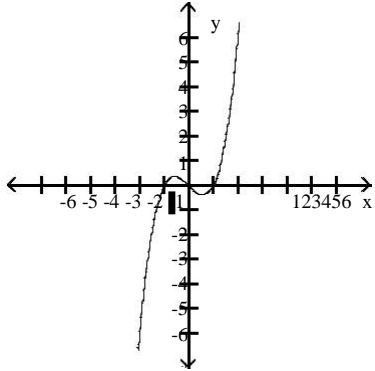

B)

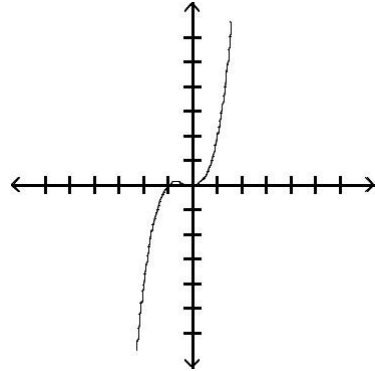

C)

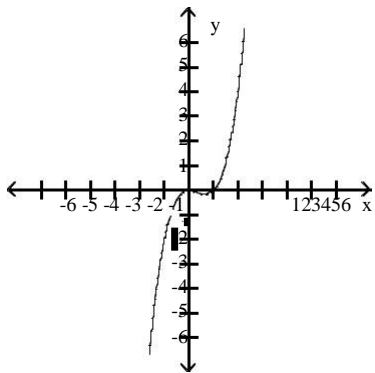

D)

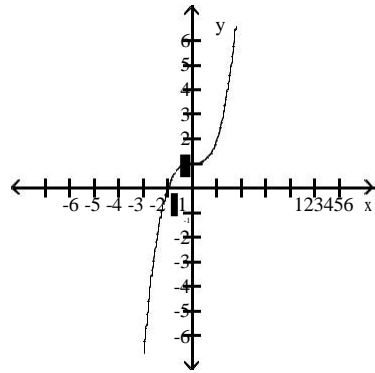

15)  $f(x) = -x^2(x+1)(x+3)$

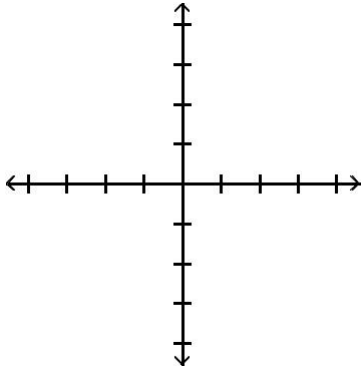

A)

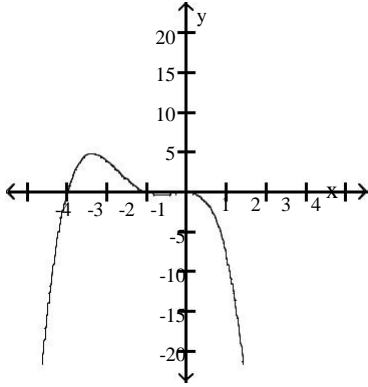

B)

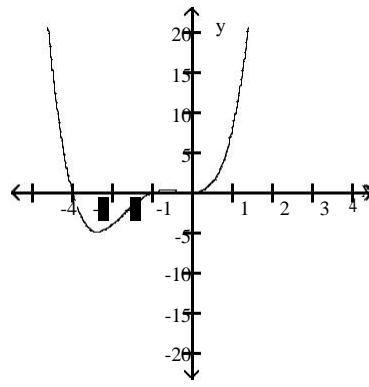

C)

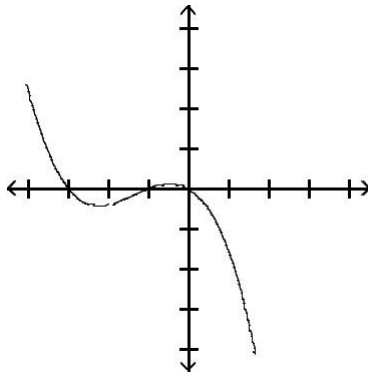

D)

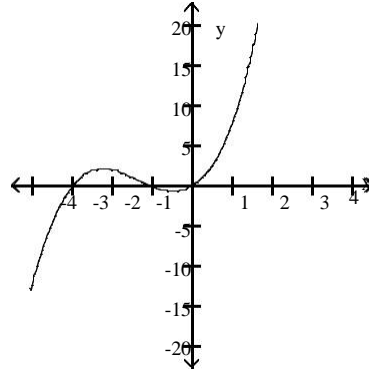

16)  $f(x) = (x+1)^2(x^2 - 25)$

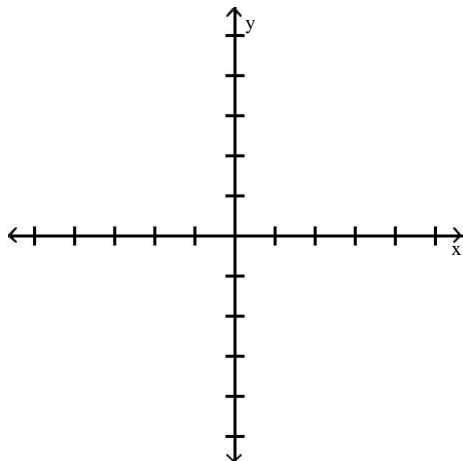

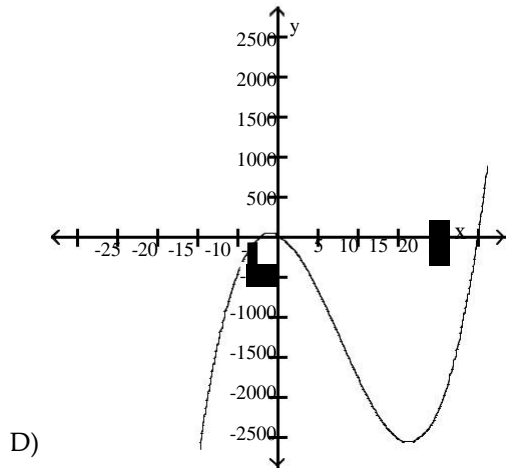
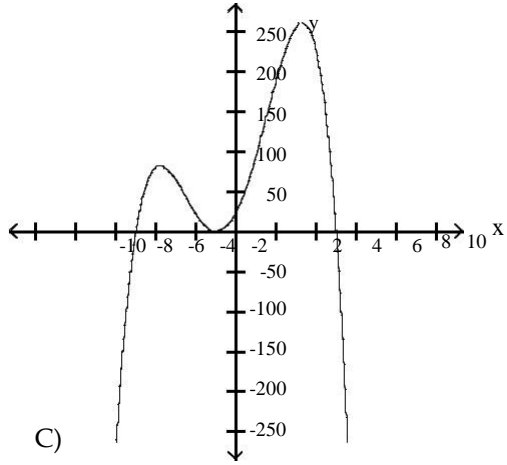
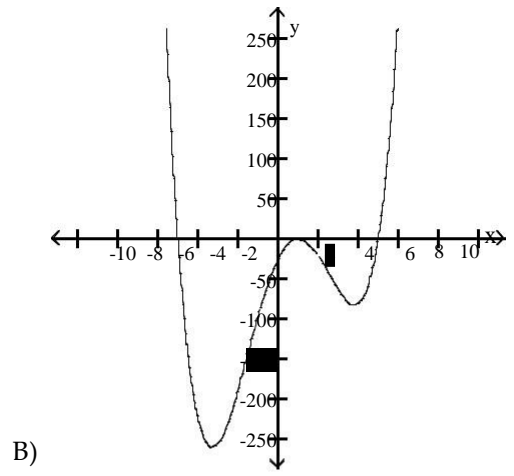
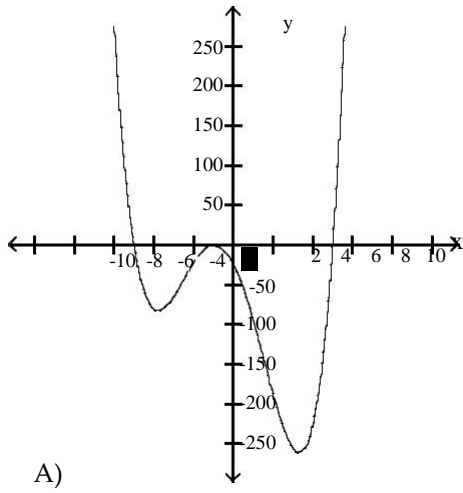

17)  $f(x) = -x^2(x-1)(x+1)$

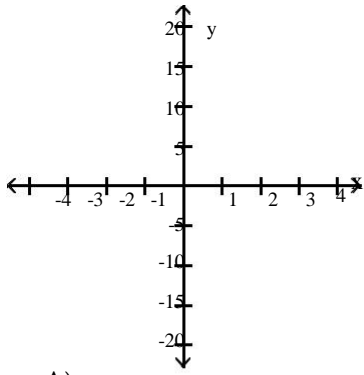

A)

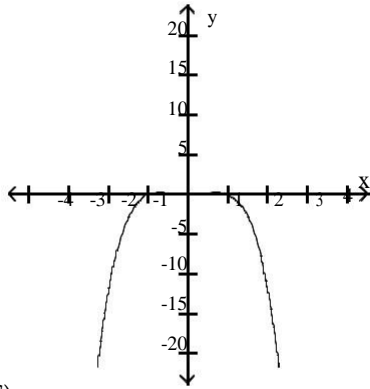

C)

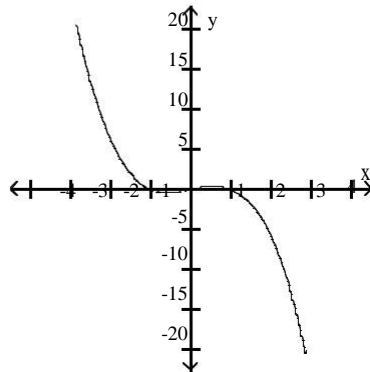

B)

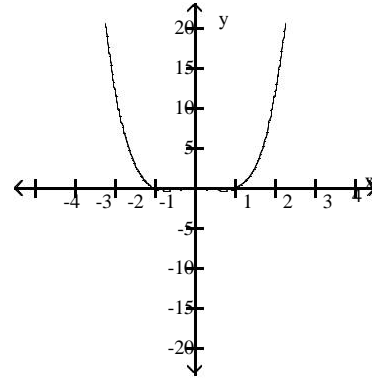

D)

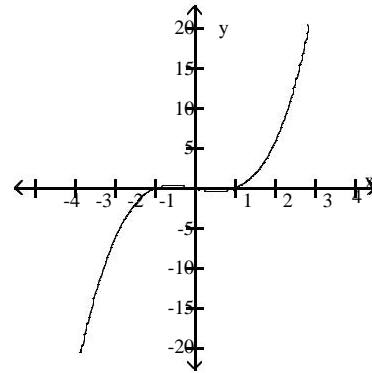

18)  $f(x) = -2x^3(x+1)^2(x+3)$

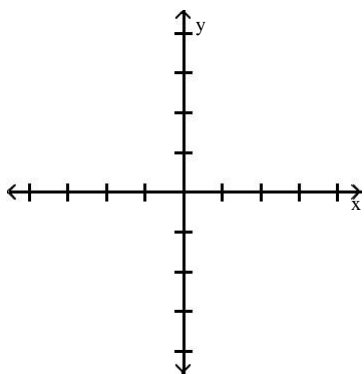

A)

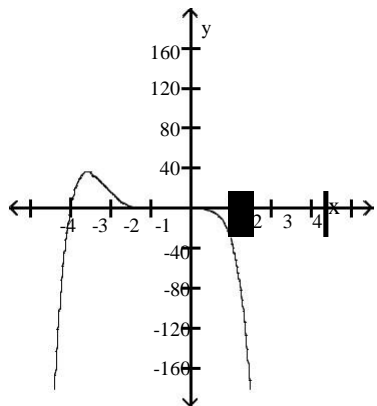

C)

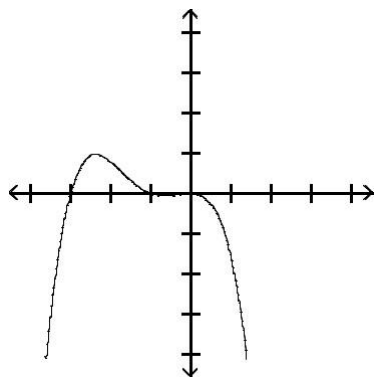

B)

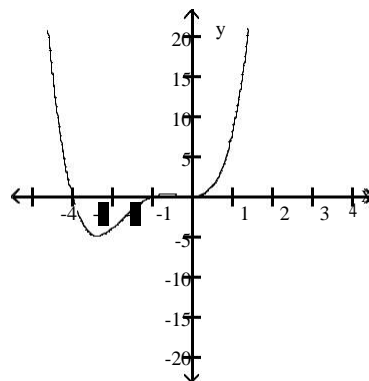

D)

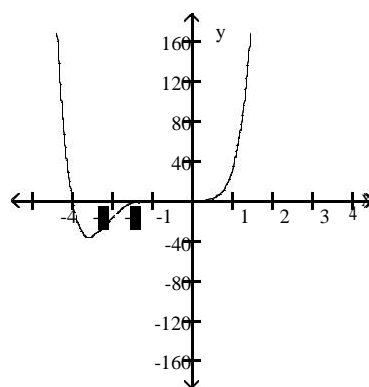

19)  $f(x) = (x - 5)(x - 3)(x - 2)$

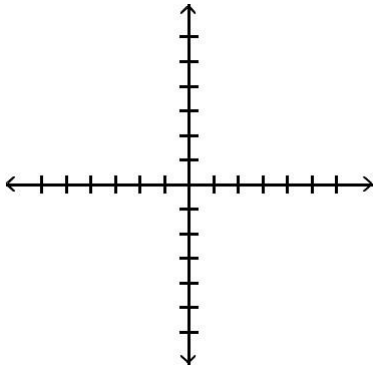

A)

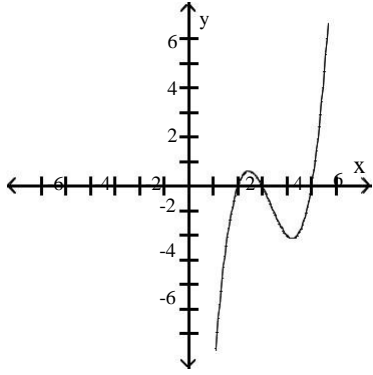

B)

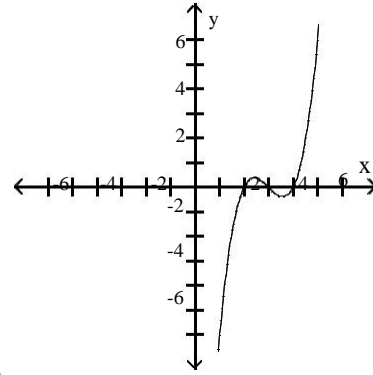

C)

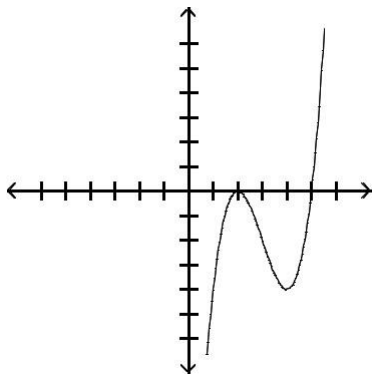

D)

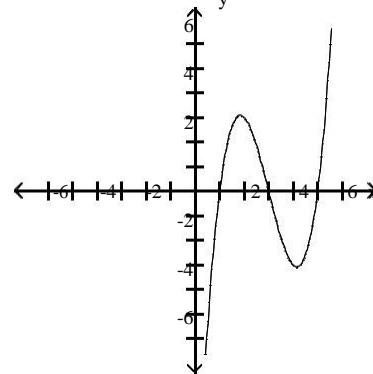



20)  $f(x) = (x + 1)(x + 3)(x + 5)^2$

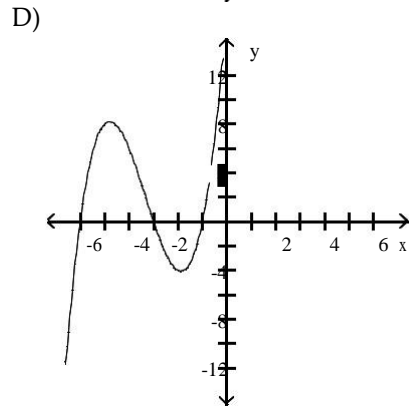
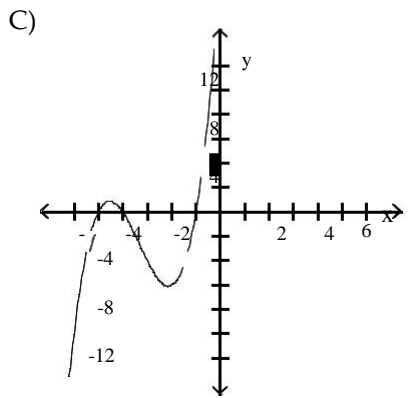
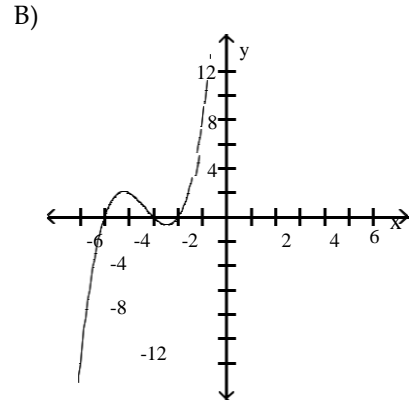
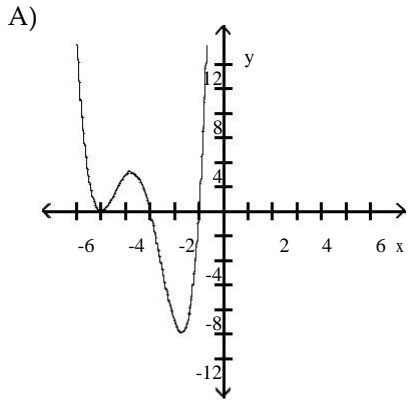
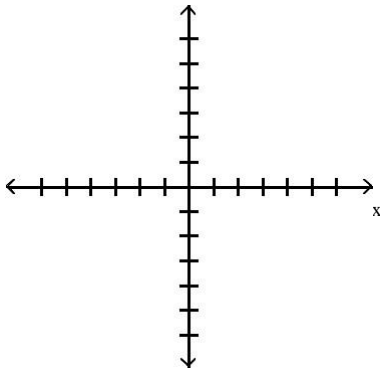

**SHORT ANSWER.** Write the word or phrase that best completes each statement or answers the question.

**Complete the following:**

Use the Leading Coefficient Test to determine the graph's end behavior.

Find the x-intercepts. State whether the graph crosses the x-axis or touches the x-axis and turns around at each intercept.

Find the y-intercept.

Graph the function.

21)  $f(x) = x^2(x + 3)$

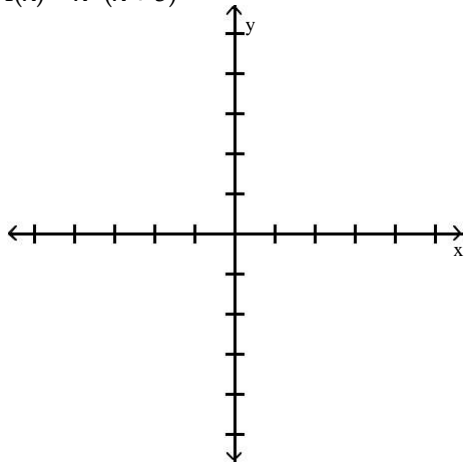

22)  $f(x) = (x + 2)(x - 3)^2$

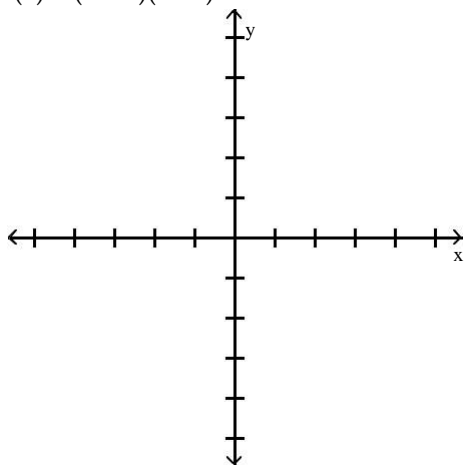

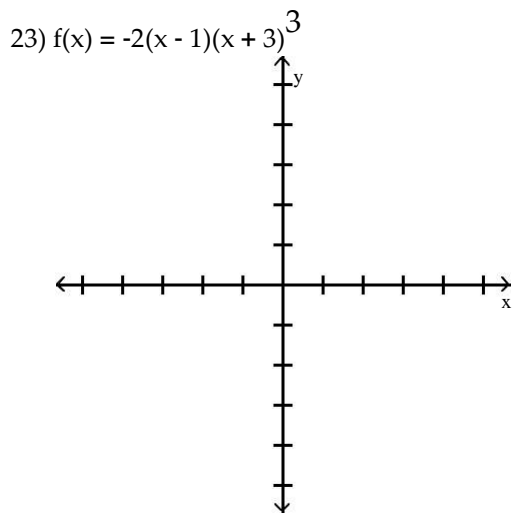

## 2.4 Dividing Polynomials; Remainder and Factor Theorems

### 1 Use Long Division to Divide Polynomials

**MULTIPLE CHOICE.** Choose the one alternative that best completes the statement or answers the question.

Divide using long division.

1)  $(x^2 + 13x + 42) \div (x + 6)$

A)  $x + 7$

B)  $x + 13$

C)  $x^2 + 7$

D)  $x^2 + 13$

2)  $(8x^2 - 67x - 45) \div (x - 9)$

A)  $8x + 5$

B)  $8x - 5$

C)  $x - 67$

$8x^2 + 67$

3)  $(-14x^2 + 23x - 3) \div (-7x + 1)$

A)  $2x - 3$

B)  $-14x - 3$

C)  $x - 3$

$-3x + 1$

4) 
$$\frac{4m^3 + 21m^2 - 47m + 14}{m + 7}$$

A)  $4m^2 - 7m + 2$

B)  $4m^2 + 7m + 2$

C)  $m^2 + 8m + 9$

D)  $m^2 + 7m + 4$

$$\frac{3r^3 - 13r^2 - 54r - 14}{r - 7}$$

A)  $3r^2 + 8r + 2$

B)  $3r^2 - 8r - 2$

C)  $3r^2 + 8r + \frac{2}{r - 7}$

$r^2 + 2r + 8$

6)  $(-20x^3 + 26x^2 - 13x + 4) \div (5x - 4)$

A)  $-4x^2 + 2x - 1$

B)  $-4x^2 - 1$

C)  $x^2 + 2x - 1$

$x^2 - 2x + 1$

7) 
$$\frac{5x^3 - 18x + 4}{x + 2}$$

A)  $5x^2 - 10x + 2$

B)  $5x^2 - 28x + \frac{60}{x + 2}$

C)  $5x^2 + 28x + \frac{60}{x + 2}$

$5x^2 + 10x + 2$

$$8) (15x^3 - 3) \div (5x - 1)$$

$$A) 3x^2 + \frac{3}{5}x + \frac{3}{25} - \frac{72}{25(5x - 1)}$$

$$C) 3x^2 + \frac{3}{5x + 25}$$

$$B) 3x^2 + \frac{3}{5}x + \frac{3}{25} + \frac{72}{25(5x - 1)}$$

$$3x^2 - \frac{3}{5}x + \frac{3}{25}$$

$$9) \frac{25x^3 + 30x^2 - 2x + 9}{-5x - 2}$$

$$A) -5x^2 - 4x + 2 + \frac{13}{-5x - 2}$$

$$C) -5x^2 - 4x + 2 + \frac{16}{-5x - 2}$$

$$\frac{x^4 + 81}{-3}$$

$$\frac{x^3 + 3x^2 + 9x + 27 + 162}{-3}$$

$$x^3 + 3x^2 + 9x + 27$$

$$-5x^2 - 4x + 2$$

$$D) x^2 + 2 + \frac{-4}{-5x - 2}$$

$$B) x^3 + 3x^2 + 9x + 27 + \frac{81}{x - 3}$$

$$\frac{x^3 - 3x^2 + 9x - 27 + 162}{-3}$$

$$(5x^4 - 3x^2 + 15x^3 - 9x) \div (5x + 15)$$

$$A) x^3 - \frac{3x}{5}$$

$$B) x^3 + \frac{3x}{5}$$

$$C) x^3 - 15x + \frac{25x}{5x + 15}$$

$$D) x^3 - \frac{3x}{5} - \frac{18x}{5x + 15}$$

$$\frac{8y^4 + 12y^3 - 2y}{2y^2 + y}$$

$$4y^2 + 4y - 2$$

$$C) 4y^2 + 4y - \frac{6y}{2y^2 + y}$$

$$B) 4y^2 + 8y + 4 + \frac{2y}{2y^2 + y}$$

$$D) 4y^2 + 6y - \frac{2y}{2y^2 + y}$$

$$13) (14x^3 + x^2 - 42x - 3) \div (7x^2 - 21)$$

$$A) 2x + \frac{1}{7}$$

$$B) 2x + 7$$

$$C) 2x + \frac{-3}{7x^2 - 21}$$

$$D) 2x + \frac{3}{7x^2 - 21}$$

$$(-2x^4 + 7x^3 + 5x^2 - 9x + 20) \div (4 - x)$$

$$2x^3 + 1x^2 - x + 5$$

$$2x^3 + 1x^2 - x - 5$$

$$C) 2x^3 + 1x^2 - x - 5 + \frac{40}{4 - x}$$

$$2x^3 + 1x^2 + x - 5$$

$$15) (-5x^5 - x^3 + 2x^2 + 255x - 14) \div (x^2 - 7)$$

$$A) -5x^3 - 36x + 2 + \frac{3x}{x^2 - 7}$$

$$-5x^3 - 36x + 2 + \frac{3x - 28}{x^2 - 7}$$

$$B) \frac{3x}{x - 7}$$

$$D) -5x^3 - 36x - 2 + \frac{3x}{x^2 - 7}$$

$$\frac{x^4 - 3x^3 - 8x^2 + 11x + 9}{x^2 - 4x - 1}$$

A)  $x^2 + x - 3 + \frac{6}{x^2 - 4x - 1}$

B)  $x^2 + x - 3$

C)  $x^2 - 8x + 23 + \frac{-85x - 26}{x^2 - 4x - 1}$

D)  $x^2 - 8x + 23$

$$\frac{4t^4 + 18t^3 - 8t^2 - 66t + 36}{2t^2 + 6t - 4}$$

A)  $2t^2 + 3t - 9$

B)  $2t^2 - 3t - 9$

C)  $2t^2 + 3t + 9$

D)  $2t^2 + 4t - 9$

**Solve the problem.**

A rectangle with width  $2x + 1$  inches has an area of  $2x^4 + 7x^3 - 17x^2 - 58x - 24$  square inches. Write a polynomial that represents its length.

A)  $x^3 + 3x^2 - 10x - 24$  inches

B)  $x^3 - 10x^2 + 3x - 24$  inches

C)  $x^3 + 5x^2 - 9x - 24$  inches

D)  $x^3 - 9x^2 + 5x - 24$  inches

The width of a rectangle is  $x - 2$  feet and its area is  $9x^3 + 12x^2 + 15x - 18$  square feet. Write a polynomial that represents the length of the rectangle.

A)  $9x^2 + 18x + 27$  ft

B)  $9x^2 - 18x + 27$  ft

C)  $9x^2 + 6x + 11$  ft

D)  $9x^2 + 18x - 27$  ft

Two people are 41 years old and 21 years old, respectively. In  $x$  years from now, their ages can be represented by  $x + 41$  and  $x + 21$ . Use long division to find the ratio of the older person's age to the younger person's age in  $x$  years.

A)  $1 + \frac{20}{x + 21}$

B)  $1 + \frac{62}{x + 21}$

C) 1.9524

D)  $1 + \frac{62}{x + 41}$

**2 Use Synthetic Division to Divide Polynomials**

**MULTIPLE CHOICE. Choose the one alternative that best completes the statement or answers the question.**

**Divide using synthetic division.**

1)  $(x^2 + 17x + 72) \div (x + 9)$

A)  $x + 8$

B)  $x - 63$

C)  $x^2 + 8$

D)  $x^3 - 63$

2)  $(x^2 + 11x + 27) \div (x + 5)$

A)  $x + 6 - \frac{3}{x + 5}$

B)  $x + 6 + \frac{3}{x + 5}$

C)  $\frac{x + 6}{x + 5}$

D)  $x + 7$

3)  $\frac{5x^2 + 33x - 56}{x + 8}$

A)  $5x - 7$

B)  $x - 7$

C)  $-7x + 8$

D)  $-5x + 7$

$$\frac{5x^3 - 17x^2 + 7x - 3}{-3}$$

A)  $5x^2 - 2x + 1$

B)  $-5x^2 + 3x + 1$

C)  $\frac{5x^2}{3} - \frac{17x}{3} + \frac{7}{3}$

D)  $-5x^2 - 3x - 1$

$$\frac{4x^3 + 10x^2 + 9x + 10}{+ 2}$$

A)  $4x^2 + 2x + 5$       B)  $-4x^2 - 2x + 5$

C)  $2x^2 + 5x + \frac{9}{2}$

D)  $4x^2x + 5 + 5$

$$\frac{x^5 + x^3 - 2}{+ 3}$$

$$x^4 - 3x^3 + 10x^2 - 30x + 90 + \frac{-272}{+ 3}$$

C)  $x^4 - 2x^2 + \frac{4}{x+3}$

$$x^4 - 3x^3 + 9x^2 - 26x + 78 + \frac{-236}{+ 3}$$

D)  $x^4 - 2 + \frac{4}{x+3}$

$$\frac{x^4 - 3x^3 + x^2 + 6x - 8}{- 1}$$

A)  $x^3 - 2x^2 - x + 5 - \frac{3}{x-1}$

B)  $x^3 - 2x^2 + x + 7 + \frac{-6}{x-1}$

C)  $x^3 + 2x^2 - x + 7 - \frac{3}{x-1}$

D)  $x^3 - 2x^2 + x + 5 + \frac{6}{x-1}$

8)  $(x^4 + 256) \div (x - 4)$

A)  $x^3 + 4x^2 + 16x + 64 + \frac{512}{x-4}$

B)  $x^3 + 4x^2 + 16x + 64 + \frac{256}{x-4}$

$$x^3 + 4x^2 + 16x + 64$$

$$x^3 - 4x^2 + 16x - 64 + \frac{512}{- 4}$$

$$(x^5 - 2x^4 - 10x^3 + x^2 - x + 128) \div (x + 3)$$

A)  $x^4 - 5x^3 + 5x^2 - 14x + 41 + \frac{5}{x+3}$

B)  $x^4 - 5x^3 + 5x^2 - 14x - 41 + \frac{5}{x+3}$

C)  $x^4 - 5x^3 + 5x^2 - 15x + 41 + \frac{9}{x+3}$

D)  $x^4 - 5x^3 + 5x^2 - 15x - 42 + \frac{9}{x+3}$

10)  $(5x^5 + 6x^4 - 4x^3 + x^2 - x + 31) \div (x + 2)$

A)  $5x^4 - 4x^3 + 4x^2 + 7x + 13 + \frac{5}{x+2}$

B)  $5x^4 - 4x^3 + 4x^2 - 7x - 14 + \frac{5}{x+2}$

C)  $5x^4 - 4x^3 + 4x^2 - 8x + 14 + \frac{8}{x+2}$

D)  $5x^4 - 4x^3 + 4x^2 - 8x - 14 + \frac{8}{x+2}$

### 3 Evaluate a Polynomial Using the Remainder Theorem

**MULTIPLE CHOICE.** Choose the one alternative that best completes the statement or answers the question.

Use synthetic division and the Remainder Theorem to find the indicated function value.

1)  $f(x) = x^4 - 4x^3 + 2x^2 + 9x + 7$ ;  $f(2)$

A) 17

B) 34

C) -17

D) 1

Page 75

2)  $f(x) = 2x^3 - 5x^2 - 5x + 8$ ;  $f(-2)$

A) -18

B) -14

C) -12

D) -38

3)  $f(x) = 6x^4 + 8x^3 + 3x^2 - 4x + 41; f(3)$   
 A) 758                                      B) 214                                      C) 1302                                      D) 2054

4)  $f(x) = x^5 + 5x^4 - 8x^3 + 3; f(3)$   
 A) 435                                      B) -435                                      C) 51                                      D) 192

$f(x) = x^4 - 2x^3 - 8x^2 + 4x - 8; f\left(\frac{1}{4}\right)$   
 A)  $-\frac{1927}{256}$                                       B)  $-\frac{1927}{1024}$                                       C)  $\frac{1927}{256}$                                       D)  $-\frac{241}{32}$

**4 Use the Factor Theorem to Solve a Polynomial Equation**

**MULTIPLE CHOICE. Choose the one alternative that best completes the statement or answers the question.**

**Solve the problem.**

1) Use synthetic division to divide  $f(x) = x^3 + 4x^2 - 15x - 18$  by  $x + 6$ . Use the result to find all zeros of  $f$ .  
 A)  $\{-6, 3, -1\}$                                       B)  $\{-6, -3, 1\}$                                       C)  $\{6, -3, 1\}$                                       D)  $\{6, 3, -1\}$

2) Solve the equation  $3x^3 - 28x^2 + 69x - 20 = 0$  given that 4 is a zero of  $f(x) = 3x^3 - 28x^2 + 69x - 20$ .  
 A)  $\left\{4, 5, \frac{1}{3}\right\}$                                       B)  $\left\{4, -5, -\frac{1}{3}\right\}$                                       C)  $\left\{4, 1, \frac{5}{3}\right\}$                                       D)  $\left\{4, -1, -\frac{5}{3}\right\}$

Solve the equation  $12x^3 - 73x^2 + 68x - 15 = 0$  given that  $\frac{1}{3}$  is a root.  
 A)  $\left\{\frac{1}{3}, \frac{3}{4}, \frac{5}{3}\right\}$                                       B)  $\left\{-\frac{1}{3}, \frac{3}{4}, -\frac{5}{3}\right\}$                                       C)  $\left\{\frac{1}{3}, \frac{5}{4}, \frac{3}{3}\right\}$                                       D)  $\left\{\frac{1}{3}, \frac{5}{4}, -3\right\}$

**Use synthetic division to show that the number given to the right of the equation is a solution of the equation, then solve the polynomial equation.**

4)  $x^3 - 5x^2 + 2x + 8 = 0; 2$   
 A)  $\{4, -1, 2\}$                                       B)  $\{-4, -1, 2\}$                                       C)  $\{4, 1, 2\}$                                       D)  $\{-4, 1, 2\}$

5)  $2x^3 + 10x^2 - 4x - 48 = 0; -3$   
 A)  $\{2, -4, -3\}$                                       B)  $\{-2, -4, -3\}$                                       C)  $\{2, 4, -3\}$                                       D)  $\{-2, 4, -3\}$

6)  $2x^3 - 5x^2 - 6x + 9 = 0; 1$   
 A)  $\left\{-\frac{3}{2}, 3, 1\right\}$                                       B)  $\left\{\frac{3}{2}, 3, 1\right\}$                                       C)  $\left\{-\frac{3}{2}, 3, 1\right\}$                                       D)  $\left\{\frac{3}{2}, -3, 1\right\}$

7)  $6x^3 + 3x^2 - 15x + 6 = 0; 1$   
 A)  $\left\{\frac{1}{2}, -2, 1\right\}$                                       B)  $\left\{-\frac{1}{2}, -2, 1\right\}$                                       C)  $\left\{\frac{1}{2}, 2, 1\right\}$                                       D)  $\left\{-\frac{1}{2}, 2, 1\right\}$



Use the graph or table to determine a solution of the equation. Use synthetic division to verify that this number is a solution of the equation. Then solve the polynomial equation.

8)  $x^3 + 6x^2 + 11x + 6 = 0$

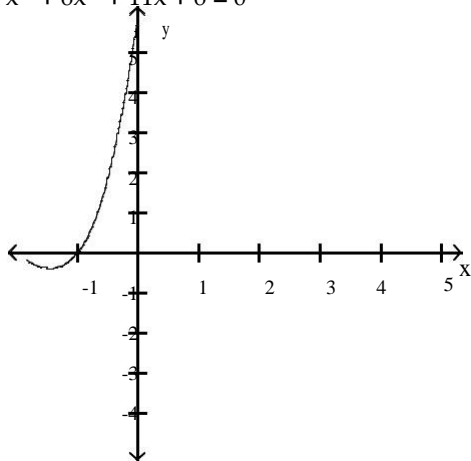

- A) -1; The remainder is zero; -1, -2, and -3, or  $\{-3, -2, -1\}$
- B) -1; The remainder is zero; 1, -2, and -3, or  $\{-3, -2, 1\}$
- C) -1; The remainder is zero; -1, 2, and -3, or  $\{-3, -1, 2\}$
- D) -1; The remainder is zero; -1, -2, and 3, or  $\{-2, -1, 3\}$

9)  $x^3 + 9x^2 + 26x + 24 = 0$

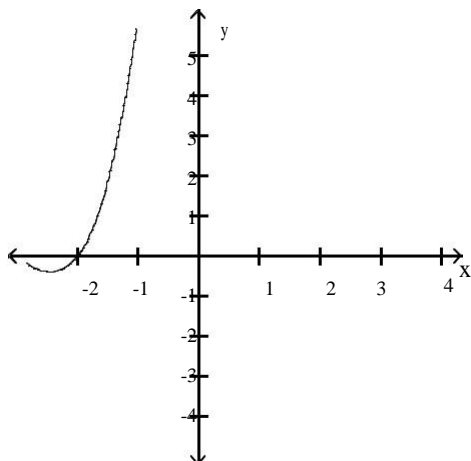

- A) -2; The remainder is zero; -2, -3, and -4, or  $\{-4, -3, -2\}$
- B) -2; The remainder is zero; 2, -3, and -4, or  $\{-4, -3, 2\}$
- C) -2; The remainder is zero; -2, 3, and -4, or  $\{-4, -2, 3\}$
- D) -2; The remainder is zero; -2, -3, and 4, or  $\{-3, -2, 4\}$

$$10) 2x^3 + 11x^2 + 17x + 6 = 0$$

	y1
-20	
-1	-2
	6
	36
	100
	210

- 2; The remainder is zero; -3, -2, and  $-\frac{1}{2}$ , or -3,  $-\frac{2}{3}$ ,  $-\frac{1}{2}$  }  $-\frac{1}{2}$  }
- 2; The remainder is zero; 3, -2, and  $-\frac{1}{2}$ , or -2,  $-\frac{1}{3}$ ,  $\frac{3}{2}$  }  $\frac{3}{2}$  }
- 2; The remainder is zero; -3, 2, and  $-\frac{1}{2}$ , or -3,  $-\frac{1}{2}$ ,  $\frac{2}{3}$  }  $\frac{2}{3}$  }
- 2; The remainder is zero; -3, -2, and  $\frac{1}{2}$ , or -3,  $-\frac{2}{3}$ ,  $\frac{1}{2}$  }  $\frac{1}{2}$  }

## 2.5 Zeros of Polynomial Functions

### 1 Use the Rational Zero Theorem to Find Possible Rational Zeros

**MULTIPLE CHOICE.** Choose the one alternative that best completes the statement or answers the question.

Use the Rational Zero Theorem to list all possible rational zeros for the given function.

$$1) f(x) = x^5 - 3x^2 + 3x + 7$$

A)  $\pm 1, \pm 7$

B)  $\pm 1, \pm \frac{1}{7}$

C)  $\pm \frac{1}{3}, \pm \frac{7}{3}, \pm 7$

D)  $\pm 7, \pm \frac{1}{7}$

$$2) f(x) = x^5 - 6x^2 + 3x + 6$$

A)  $\pm 1, \pm 3, \pm 2, \pm 6$

B)  $\pm 1, \pm \frac{1}{3}, \pm \frac{1}{2}, \pm \frac{1}{6}$

C)  $\pm 1, \pm \frac{1}{3}, \pm \frac{1}{2}, \pm \frac{1}{6}, \pm 3, \pm 2, \pm 6$

D)  $\pm 1, \pm 3, \pm 2$

$$f(x) = x^4 + 3x^3 - 4x^2 + 4x - 12$$

$\pm 1, \pm 2, \pm 3, \pm 4, \pm 6, \pm 12$

B)  $\pm 1, \pm \frac{1}{2}, \pm \frac{1}{3}, \pm \frac{1}{4}, \pm \frac{1}{6}, \pm \frac{1}{12}$

C)  $\pm \frac{1}{2}, \pm \frac{1}{3}, \pm \frac{1}{4}, \pm \frac{1}{6}, \pm \frac{1}{12}, \pm 1, \pm 2, \pm 3, \pm 4, \pm 6, \pm 12$

$\pm \frac{1}{12}, \pm 1, \pm 12$

$$f(x) = -2x^3 + 2x^2 - 3x + 8$$

A)  $\pm \frac{1}{2}, \pm 1, \pm 2, \pm 4, \pm 8$

B)  $\pm \frac{1}{4}, \pm \frac{1}{2}, \pm 1, \pm 2, \pm 4, \pm 8$

C)  $\pm \frac{1}{8}, \pm \frac{1}{4}, \pm \frac{1}{2}, \pm 1, \pm 2, \pm 4, \pm 8$

D)  $\pm \frac{1}{2}, \pm 1, \pm 2, \pm 4$

$$5) f(x) = 7x^3 - x^2 + 3$$

$$A) \pm \frac{1}{7}, \pm \frac{3}{7}, \pm 1, \pm 3$$

$$B) \pm \frac{1}{3}, \pm \frac{7}{3}, \pm 1, \pm 7$$

$$C) \pm \frac{1}{7}, \pm \frac{3}{7}, \pm 1, \pm 3, \pm 7$$

$$D) \pm \frac{1}{7}, \pm \frac{1}{3}, \pm 1, \pm 3, \pm 7$$

$$6) f(x) = 6x^4 + 4x^3 - 3x^2 + 2$$

$$A) \pm \frac{1}{6}, \pm \frac{1}{3}, \pm \frac{1}{2}, \pm \frac{2}{3}, \pm 1, \pm 2$$

$$B) \pm \frac{1}{6}, \pm \frac{1}{32}, \pm \frac{1}{3}, \pm \frac{2}{3}, \pm 1, \pm 2, \pm 3$$

$$C) \pm \frac{1}{6}, \pm \frac{1}{3}, \pm \frac{1}{2}, \pm 1, \pm 2$$

$$D) \pm \frac{1}{2}, \pm \frac{3}{2}, \pm 1, \pm 2, \pm 3, \pm 6$$

$$7) f(x) = -4x^4 + 2x^2 - 3x + 6$$

$$A) \pm \frac{1}{4}, \pm \frac{1}{2}, \pm \frac{3}{4}, \pm \frac{3}{2}, \pm 1, \pm 2, \pm 3, \pm 6$$

$$B) \pm \frac{1}{6}, \pm \frac{1}{2}, \pm \frac{1}{3}, \pm \frac{2}{3}, \pm \frac{4}{3}, \pm 1, \pm 2, \pm 4$$

$$C) \pm \frac{1}{4}, \pm \frac{1}{2}, \pm \frac{3}{4}, \pm \frac{3}{2}, \pm 1, \pm 2, \pm 3, \pm 4, \pm 6$$

$$D) \pm \frac{1}{4}, \pm \frac{1}{2}, \pm \frac{2}{3}, \pm \frac{3}{4}, \pm \frac{3}{2}, \pm 1, \pm 2, \pm 3, \pm 6$$

$$8) f(x) = 3x^5 - 5x^2 + 3x - 1$$

$$A) \pm 1, \pm \frac{1}{3}$$

$$B) \pm 1, \pm 3$$

$$C) \pm 1, \pm 3, \pm \frac{1}{3}$$

$$D) \pm 3, \pm \frac{1}{3}$$

$$9) f(x) = 6x^4 + 3x^3 - 5x^2 + 6x - 5$$

$$A) \pm 1, \pm 5, \pm \frac{1}{2}, \pm \frac{5}{2}, \pm \frac{1}{3}, \pm \frac{5}{3}, \pm \frac{1}{6}, \pm \frac{5}{6}$$

$$B) \pm 1, \pm 2, \pm 3, \pm 6, \pm \frac{1}{5}, \pm \frac{2}{5}, \pm \frac{3}{5}, \pm \frac{6}{5}$$

$$C) \pm 1, \pm 2, \pm 3, \pm 6, \pm \frac{1}{2}, \pm \frac{5}{2}, \pm \frac{1}{3}, \pm \frac{5}{3}, \pm \frac{1}{6}, \pm \frac{5}{6}$$

$$D) \pm 1, \pm 5, \pm \frac{1}{5}, \pm \frac{2}{5}, \pm \frac{3}{5}, \pm \frac{6}{5}$$

$$f(x) = 3x^4 + 7x^3 - 4x^2 + 6x - 12$$

$$\pm 1, \pm 2, \pm 3, \pm 4, \pm 6, \pm 12, \pm \frac{1}{3}, \pm \frac{2}{3}, \pm \frac{4}{3}$$

$$B) \pm 1, \pm 3, \pm \frac{1}{2}, \pm \frac{3}{2}, \pm \frac{1}{3}, \pm \frac{1}{4}, \pm \frac{3}{4}, \pm \frac{1}{6}, \pm \frac{1}{12}$$

$$C) \pm 1, \pm 2, \pm 3, \pm 4, \pm 6, \pm 12, \pm \frac{1}{2}, \pm \frac{3}{2}, \pm \frac{1}{3}, \pm \frac{1}{4}, \pm \frac{3}{4}, \pm \frac{1}{6}, \pm \frac{1}{12}$$

$$D) \pm 1, \pm 2, \pm 3, \pm 6, \pm 12, \pm \frac{1}{3}, \pm \frac{2}{3}, \pm \frac{3}{4}$$

## 2 Find Zeros of a Polynomial Function

**MULTIPLE CHOICE.** Choose the one alternative that best completes the statement or answers the question.

**Find a rational zero of the polynomial function and use it to find all the zeros of the function.**

$$1) f(x) = x^3 + 2x^2 - 9x - 18$$

$$A) \{-3, -2, 3\}$$

$$B) \{-3, 2, 3\}$$

$$C) \{-3\}$$

$$D) \{-2\}$$

$$2) f(x) = 2x^3 - 11x^2 + 10x + 8$$

$$A) \left\{ \begin{array}{l} -1 \\ 2 \end{array} , 2, 4 \right\}$$

$$B) \left\{ \begin{array}{l} 1 \\ 2 \end{array} , 2, -4 \right\}$$

$$C) \{ 2, -1, 2 \}$$

$$D) \{ -2, -1, -2 \}$$

$$3) f(x) = x^3 + 6x^2 - x - 6$$

A) {1, -1, -6}

B) {-1, 2, 3}

C) {1, 2, -3}

D) {1, -1, 6}

$$4) f(x) = x^3 + 7x^2 + 8x + 2$$

A) {-1, -3 +  $\sqrt{7}$ , -3 -  $\sqrt{7}$ }

B) {1, -1, -2}

C) {1, -6 +  $\sqrt{7}$ , -6 -  $\sqrt{7}$ }

D) {-1, -6 +  $\sqrt{7}$ , -6 -  $\sqrt{7}$ }

$$5) f(x) = x^3 + 8x^2 + 30x + 36$$

A) {-2, -3 + 3i, -3 - 3i}

B) {-2, 3 + 3i, 3 - 3i}

C) {2, -3 +  $\sqrt{2}$ , -3 -  $\sqrt{2}$ }

D) {-2, 3 +  $\sqrt{2}$ , 3 -  $\sqrt{2}$ }

$$6) f(x) = 3x^3 - x^2 - 21x + 7$$

A) { $\frac{1}{3}$ ,  $\sqrt{7}$ , - $\sqrt{7}$ }

B) {- $\frac{1}{3}$ ,  $\sqrt{7}$ ,  $\sqrt{7}$ }

C) {3,  $\sqrt{7}$ , - $\sqrt{7}$ }

D) {-3,  $\sqrt{7}$ , - $\sqrt{7}$ }

$$7) f(x) = x^4 + 4x^3 - 9x^2 - 30x - 18$$

A) {-1, 3, -3 +  $\sqrt{3}$ , -3 -  $\sqrt{3}$ }

B) {1, -3, -3 +  $\sqrt{3}$ , -3 -  $\sqrt{3}$ }

C) {-1, 4, -3 +  $\sqrt{5}$ , -3 -  $\sqrt{5}$ }

D) {-1, -3, -3 +  $\sqrt{5}$ , -3 -  $\sqrt{5}$ }

$$8) f(x) = x^4 - 4x^3 + 3x^2 + 54x - 54$$

A) {-3, 1, 3 + 3i, 3 - 3i}

B) {3, -1, 3 + 3i, 3 - 3i}

C) {-3, 1, 3 + 4i, 3 - 4i}

D) {3, -1, 3 +  $\sqrt{3}$ , 3 -  $\sqrt{3}$ }

$$9) f(x) = 2x^4 - 17x^3 + 58x^2 - 77x + 26$$

A) {2,  $\frac{1}{2}$ , 3 + 2i, 3 - 2i}

B) {-2, - $\frac{1}{2}$ , 2 + 3i, 2 - 3i}

C) {2, - $\frac{1}{2}$ , 2 + 3i, 2 - 3i}

D) {-2,  $\frac{1}{2}$ , 3 + 2i, 3 - 2i}

$$10) f(x) = 3x^4 + 22x^3 + 82x^2 + 142x + 39$$

A) {-3, - $\frac{1}{3}$ , -2 + 3i, -2 - 3i}

B) {3, + $\frac{1}{3}$ , -3 + 2i, -3 - 2i}

C) {-3, + $\frac{1}{3}$ , -3 + 2i, -3 - 2i}

D) {3, - $\frac{1}{3}$ , -2 + 3i, -2 - 3i}

### 3 Solve Polynomial Equations

**MULTIPLE CHOICE.** Choose the one alternative that best completes the statement or answers the question.

**Solve the polynomial equation. In order to obtain the first root, use synthetic division to test the possible rational roots.**

$$1) x^3 + 3x^2 - 4x - 12 = 0$$

A) {-3, -2, 2}

B) {-2, 2, 3}

C) {-3}

D) {-2}

$$2) 2x^3 - 11x^2 + 17x - 6 = 0$$

A) { $\frac{1}{2}$ , 2, 3}

B) { $-\frac{1}{2}$ , 2, -3}

C) { $\frac{3}{2}$ , 1, 2}

D) { $-\frac{3}{2}$ , 1, -2}

$$3) x^3 + 3x^2 - x - 3 = 0$$

A) {1, -1, -3}

B) {-1, 1, 3}

C) {1, 1, -3}

D) {1, -1, 3}

$$4) x^3 + 8x^2 + 18x + 12 = 0$$

A) {-2, -3 +  $\sqrt{3}$ , -3 -  $3\sqrt{3}$ }

C) {2, -6 +  $\sqrt{3}$ , 3,  $-\sqrt{3}$ }

B) {1, -1, -12}

D) {-2, -6 +  $\sqrt{12}$ , -6 -  $\sqrt{12}$ }

$$5) x^3 + 6x^2 + 21x + 26 = 0$$

A) {-2, -2 + 3i, -2 - 3i}

C) {2, -2 +  $\sqrt{2}$ , -4,  $\sqrt{2}$ }

B) {-2, 3 + 2i, 3 - 2i}

D) {-2, 3 +  $\sqrt{2}$ , 3 - 2,  $\sqrt{2}$ }

$$6) x^3 + 3x^2 - 8x + 10 = 0$$

A) {1 + i, 1 - i, -5}

B) {1 + i, 1 - i, 5}

C) {-5, 5}

D) {1 + i, 1 - i, 5i}

$$7) 2x^3 - x^2 - 10x + 5 = 0$$

A) { $\frac{1}{2}\sqrt{5}$ ,  $-\sqrt{5}$ }

B) { $-\frac{1}{2}\sqrt{5}$ ,  $\sqrt{5}$ }

C) {2,  $\sqrt{5}$ ,  $-\sqrt{5}$ }

D) {-2,  $\sqrt{5}$ ,  $5\sqrt{5}$ }

$$8) x^4 + 4x^3 - 11x^2 - 26x - 12 = 0$$

A) {-1, 3, -3 +  $\sqrt{5}$ , -3 -  $\sqrt{5}$ }

C) {-1, 4, -3 +  $\sqrt{2}$ , -3 -  $\sqrt{2}$ }

B) {1, -3, -3 +  $\sqrt{5}$ , -3 -  $\sqrt{5}$ }

D) {-1, -3, -3 +  $\sqrt{2}$ , -3 -  $\sqrt{2}$ }

$$9) x^4 - 5x^3 + 10x^2 + 30x - 36 = 0$$

A) {-2, 1, 3 + 3i, 3 - 3i}

C) {-2, 1, 3 + 4i, 3 - 4i}

B) {2, -1, 3 + 3i, 3 - 3i}

D) {2, -1, 3 + 3,  $3\sqrt{3}$ ,  $\sqrt{3}$ }

$$10) 2x^4 - 15x^3 + 57x^2 - 103x + 39 = 0$$

A) {3,  $\frac{1}{2}$ , 2 + 3i, 2 - 3i}

C) {3,  $-\frac{1}{2}$ , 3 + 2i, 3 - 2i}

B) {-3,  $-\frac{1}{2}$ , 3 + 2i, 3 - 2i}

D) {-3,  $\frac{1}{2}$ , 2 + 3i, 2 - 3i}

$$11) 3x^4 + 22x^3 + 64x^2 + 58x + 13 = 0$$

A) {-1,  $-\frac{1}{3}$ , -3 + 2i, -3 - 2i}

C) {-1,  $+\frac{1}{3}$ , -2 + 3i, -2 - 3i}

B) {1,  $+\frac{1}{3}$ , -2 + 3i, -2 - 3i}

D) {1,  $-\frac{1}{3}$ , -3 + 2i, -3 - 2i}

**Solve the problem.**

The concentration, in parts per million, of a particular drug in a patient's blood  $x$  hours after the drug is administered is given by the function

$$f(x) = -x^4 + 8x^3 - 23x^2 + 28x$$

How many hours after the drug is administered will it be eliminated from the bloodstream.

A) 4 hours

B) 7 hours

C) 6 hours

D) 11 hours

A box with an open top is formed by cutting squares out of the corners of a rectangular piece of cardboard and then folding up the sides. If  $x$  represents the length of the side of the square cut from each corner, and if the original piece of cardboard is 15 inches by 13 inches, what size square must be cut if the volume of the box is to be 189 cubic inches?

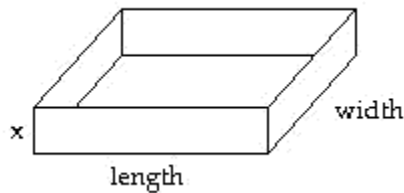
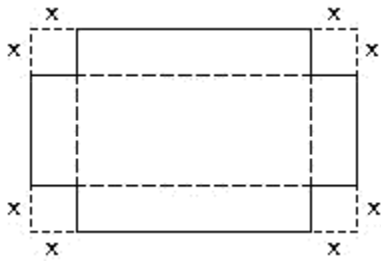

- A) 3 in. by 3 in. square  
C) 9 in. by 9 in. square

- B) 4 in. by 4 in. square  
D) 7 in. by 7 in. square

14) The polynomial function

$$H(x) = -0.001183x^4 + 0.05495x^3 - 0.8523x^2 + 9.054x + 6.748$$

models the age in human years,  $H(x)$ , of a dog that is  $x$  years old, where  $x \geq 1$ . Using the graph of this function shown below, what is the approximately equivalent dog age for a person who is 50?

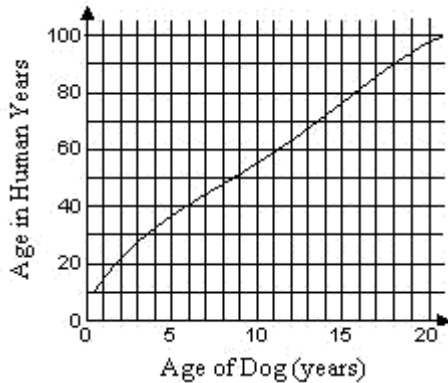

A) 9 years

B) 7 years

C) 6 years

D) 10 years

#### 4 Use the Linear Factorization Theorem to Find Polynomials with Given Zeros

**MULTIPLE CHOICE.** Choose the one alternative that best completes the statement or answers the question.

**Find an  $n$ th degree polynomial function with real coefficients satisfying the given conditions.**

1)  $n = 3$ ; 3 and  $i$  are zeros;  $f(2) = 15$

A)  $f(x) = -3x^3 + 9x^2 - 3x + 9$

B)  $f(x) = 3x^3 - 9x^2 + 3x - 9$

C)  $f(x) = 3x^3 - 9x^2 - 3x + 9$

D)  $f(x) = -3x^3 + 9x^2 + 3x - 9$

2)  $n = 3$ ; -4 and  $i$  are zeros;  $f(-3) = 60$

A)  $f(x) = 6x^3 + 24x^2 + 6x + 24$

B)  $f(x) = 6x^3 + 24x^2 - 6x - 24$

C)  $f(x) = -6x^3 - 24x^2 - 6x - 24$

D)  $f(x) = -6x^3 - 24x^2 + 6x + 24$

3)  $n = 3$ ; -2 and  $-2 + 3i$  are zeros; leading coefficient is 1

A)  $f(x) = x^3 + 6x^2 + 21x + 26$

B)  $f(x) = x^3 - 4x^2 + 21x + 26$

$$C) f(x) = x^3 + 6x^2 + 15x + 26$$

$$D) f(x) = x^3 + 5x^2 + 21x - 14$$



$n = 4$ ;  $3$ ,  $-\frac{1}{7}$ , and  $1 + 3i$  are zeros;  $f(1) = 162$

A)  $f(x) = -6x^4 + 27x^3 - 81x^2 + 132x + 90$

B)  $f(x) = 2x^4 - 9x^3 + 27x^2 + 132x + 90$

C)  $f(x) = -3x^4 + 27x^3 - 81x^2 + 132x + 90$

D)  $f(x) = 4x^4 - 18x^3 + 54x^2 - 88x - 60$

5)  $n = 4$ ;  $2i$ ,  $4$ , and  $-4$  are zeros; leading coefficient is  $1$

A)  $f(x) = x^4 - 12x^2 - 64$

B)  $f(x) = x^4 + 4x^3 - 12x^2 - 64$

C)  $f(x) = x^4 + 4x^2 - 64$

D)  $f(x) = x^4 + 4x^2 - 4x - 64$

## 5 Use Descartes's Rule of Signs

**MULTIPLE CHOICE.** Choose the one alternative that best completes the statement or answers the question.

Use Descartes's Rule of Signs to determine the possible number of positive and negative real zeros for the given function.

$f(x) = -9x^9 + x^5 - x^2 + 8$

3 or 1 positive zeros, 2 or 0 negative zeros

3 or 1 positive zeros, 3 or 1 negative zeros

2 or 0 positive zeros, 2 or 0 negative zeros

2 or 0 positive zeros, 3 or 1 negative zeros

$f(x) = 9x^3 - 4x^2 + x + 4.5$

2 or 0 positive zeros, 1 negative zero

3 or 1 positive zeros, 1 negative zero

2 or 0 positive zeros, no negative zeros

3 or 1 positive zeros, 2 or 0 negative zeros

$f(x) = 4x^7 - 3x^4 + x + 5$

2 or 0 positive zeros, 1 negative zero

3 or 1 positive zeros, 3 or 1 negative zeros

2 or 0 positive zeros, 1 or 0 negative zeros

2 or 0 positive zeros, 2 or 0 negative zeros

$f(x) = x^5 + x^4 + x^2 + x + 6$

0 positive zeros, 3 or 1 negative zeros

0 positive zeros, 0 negative zeros

0 positive zeros, 2 or 0 negative zeros

0 positive zeros, 1 negative zero

$f(x) = x^5 - 2.7x^4 - 18.71x^3 + 3x^2 + 38.88x - 9.791$

3 or 1 positive zeros, 2 or 0 negative zeros

2 or 0 positive zeros, 2 or 0 negative zeros

3 or 1 positive zeros, 3 or 1 negative zeros

2 or 0 positive zeros, 3 or 1 negative zeros

$f(x) = x^6 - 17$

1 positive zero, 1 negative zero

1 positive zero, 0 negative zeros

0 positive zeros, 0 negative zeros

0 positive zeros, 1 negative zero

$f(x) = 7x^4 - 10x^3 + x^2 - 3.5x + 20$

4, 2 or 0 positive zeros, no negative zeros

4 or 2 positive zeros, no negative zeros

4, 2 or 0 positive zeros, 1 negative zero

4 positive zeros, no negative zeros

$f(x) = -7x^7 - 8x^6 - 4x^5 + 6x^4 + x + 16$

1 positive zero, 4, 3 or 1 negative zeros

1 positive zero, 2 or 0 negative zeros

1 positive zero, 4 or 2 negative zeros

1 positive zero, 3 or 1 negative zeros

## 2.6 Rational Functions and Their Graphs

### 1 Find the Domains of Rational Functions

**MULTIPLE CHOICE.** Choose the one alternative that best completes the statement or answers the question.

**Find the domain of the rational function.**

$$h(x) = \frac{4x}{x + 7}$$

A)  $\{x \mid x \neq -7\}$

B)  $\{x \mid x \neq 7\}$

C)  $\{x \mid x \neq 0\}$

D) all real numbers

$$5x^2$$

2)  $f(x) = \frac{1}{(x - 7)(x - 2)}$

A)  $\{x \mid x \neq 7, x \neq 2\}$

$\{x \mid x \neq 7, x \neq 2, x \neq -5\}$

$\{x \mid x \neq -7, x \neq -2\}$

all real numbers

$$h(x) = \frac{x + 9}{x^2 - 64}$$

$$x^2 - 64$$

$\{x \mid x \neq -8, x \neq 8\}$

$\{x \mid x \neq 0, x \neq 64\}$

$\{x \mid x \neq -8, x \neq 8, x \neq -9\}$

all real numbers

4)  $f(x) = \frac{x + 6}{x^2 + 49}$

$$x^2 + 49$$

all real numbers

$\{x \mid x \neq 0, x \neq -49\}$

$\{x \mid x \neq -7, x \neq 7, x \neq -6\}$

$\{x \mid x \neq -7, x \neq 7\}$

5)  $h(x) = \frac{x + 3}{x^2 + 64x}$

$\{x \mid x \neq 0, x \neq -64\}$

all real numbers

$\{x \mid x \neq -8, x \neq 8, x \neq -3\}$

$\{x \mid x \neq -8, x \neq 8\}$

### 2 Use Arrow Notation

**MULTIPLE CHOICE.** Choose the one alternative that best completes the statement or answers the question.

Use the graph of the rational function shown to complete the statement.

1)

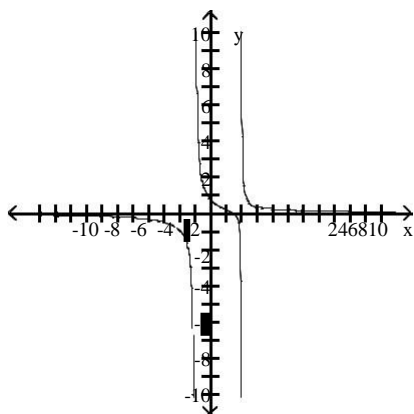

As  $x \rightarrow -1^+$ ,  $f(x) \rightarrow ?$   
A)  $+\infty$

B)  $-\infty$

C) 0

D) -1

2)

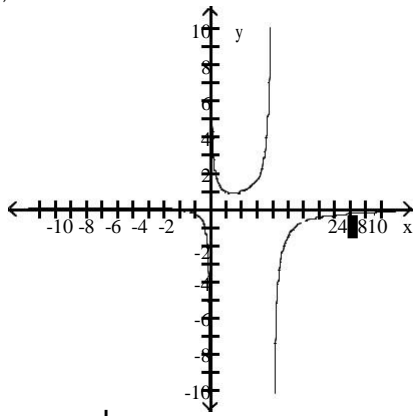

As  $x \rightarrow 4^+$ ,  $f(x) \rightarrow ?$

A)  $-\infty$

B)  $+\infty$

C) 0

D) 4

3)

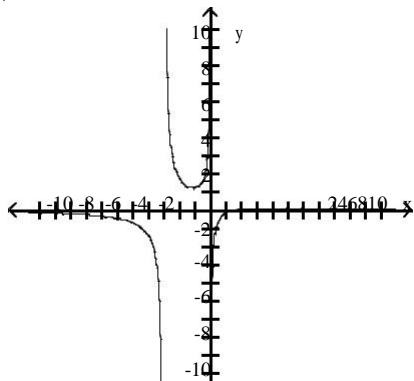

As  $x \rightarrow +\infty$ ,  $f(x) \rightarrow ?$

A) 0

B)  $+\infty$

C)  $-\infty$

D) 1

4)

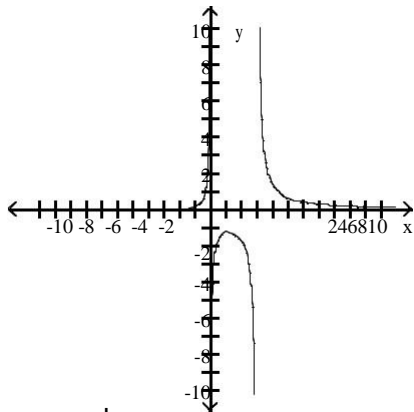

As  $x \rightarrow 3^+$ ,  $f(x) \rightarrow ?$

A)  $+\infty$

B)  $-\infty$

C) 0

D) 3

5)

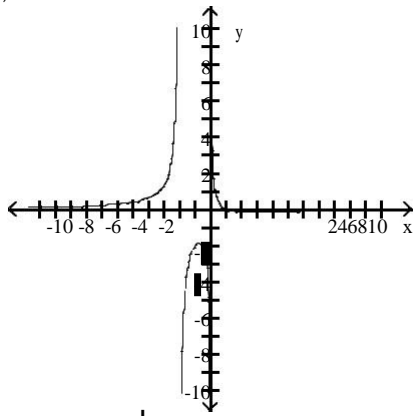

As  $x \rightarrow -2^+$ ,  $f(x) \rightarrow ?$

A)  $-\infty$

B)  $+\infty$

C) 0

D) -2

6)

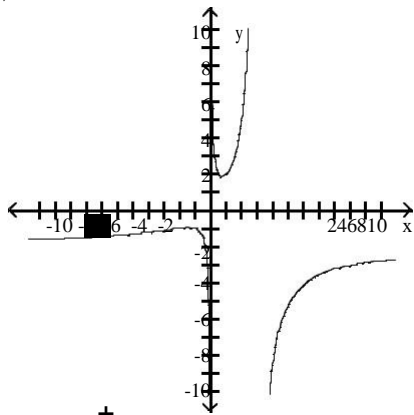

As  $x \rightarrow 0^+$ ,  $f(x) \rightarrow ?$

A)  $+\infty$

B)  $-\infty$

C) 2

D) 0

7)

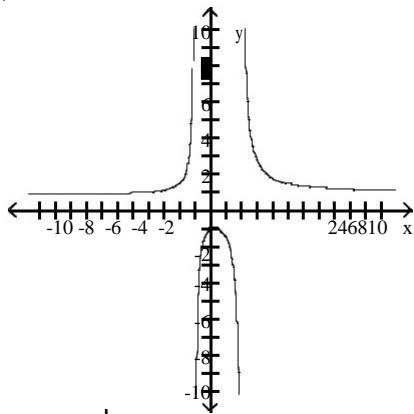

As  $x \rightarrow 2^+$ ,  $f(x) \rightarrow ?$

A)  $+\infty$

B)  $-\infty$

C) 1

D) -2

8)

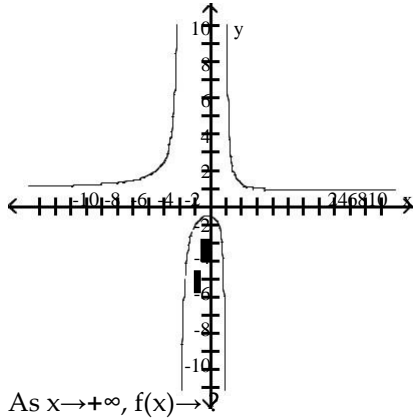

A) 1

B)  $+\infty$

C)  $-\infty$

D) -1

9)

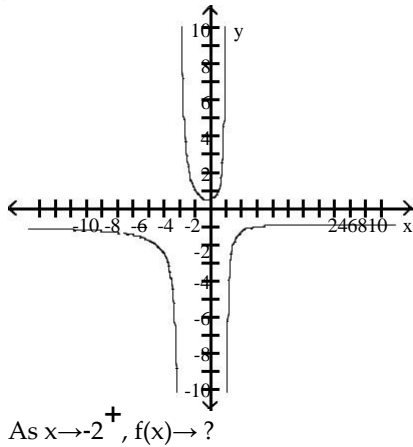

A)  $+\infty$

B)  $-\infty$

C) -1

D) 1

### 3 Identify Vertical Asymptotes

**MULTIPLE CHOICE.** Choose the one alternative that best completes the statement or answers the question.

Find the vertical asymptotes, if any, of the graph of the rational function.

$$h(x) = \frac{x}{x-1}$$

A)  $x = 1$

C)  $x = 0$  and  $x = -1$

B)  $x = 0$  and  $x = 1$

D) no vertical asymptote

$$2) h(x) = \frac{x+2}{x(x+2)}$$

A)  $x = 0$  and  $x = -2$

C)  $x = -2$  and  $x = -2$

B)  $x = -2$

D) no vertical asymptote

$$3) h(x) = \frac{x}{x(x-2)}$$

A)  $x = 2$

C)  $x = 0$  and  $x = -2$

B)  $x = 0$  and  $x = 2$

D) no vertical asymptote

$$4) f(x) = -\frac{x}{x^2 + 9}$$

A)  $x = -9$

C)  $x = 9$

B)  $x = -9, x = 9$

D) no vertical asymptote

$$5) g(x) = \frac{x}{x^2 - 36}$$

A)  $x = 6, x = -6$

C)  $x = 6$

B)  $x = 6, x = -6, x = 0$

D) no vertical asymptote

$$6) h(x) = \frac{x + 4}{x^2 - 16}$$

A)  $x = 4$

C)  $x = 4, x = -4$

B)  $x = -4$

D) no vertical asymptote

$$7) \frac{x - 16}{x^2 - 13x + 36}$$

A)  $x = 4, x = 9$

C)  $x = 4, x = 9, x = -16$

B)  $x = -4, x = -9$

D)  $x = -16$

#### 4 Identify Horizontal Asymptotes

**MULTIPLE CHOICE.** Choose the one alternative that best completes the statement or answers the question.

Find the horizontal asymptote, if any, of the graph of the rational function.

$$1) f(x) = \frac{20x}{5x^2 + 1}$$

A)  $y = 0$

C)  $y = \frac{1}{4}$

B)  $y = 4$

D) no horizontal asymptote

$$g(x) = \frac{4x^2 - 2}{x^2 + 1}$$

A)  $y = 2$

C)  $y = \frac{1}{2}$

B)  $y = 0$

D) no horizontal asymptote

$$h(x) = \frac{15x^3}{3x^2 + 1}$$

A)  $y = 5$

C)  $y = \frac{1}{5}$

B)  $y = 0$

D) no horizontal asymptote

$$4) f(x) = \frac{-3x}{3x+6}$$

A)  $y = 1$

C)  $y = 0$

B)  $y = -2$

D) no horizontal asymptote

$$h(x) = \frac{-5x-1}{3x+3}$$

A)  $y = -\frac{5}{3}$

C)  $y = -5$

B)  $y = -\frac{1}{3}$

D) no horizontal asymptote

$$g(x) = \frac{5x^2 - 9x - 8}{3x^2 - 4x + 2}$$

A)  $y = \frac{5}{3}$

C)  $y = \frac{9}{4}$

B)  $y = 0$

D) no horizontal asymptote

$$7) f(x) = \frac{-10x}{5x^3 + x^2 + 1}$$

A)  $y = 0$

C)  $y = -\frac{1}{2}$

B)  $y = -2$

D) no horizontal asymptote



## 5 Use Transformations to Graph Rational Functions

**MULTIPLE CHOICE.** Choose the one alternative that best completes the statement or answers the question.  
 Use transformations of  $f(x) = \frac{1}{x}$  or  $f(x) = \frac{1}{x^2}$  to graph the rational function.

1)  $f(x) = \frac{1}{x-3}$

1)  $f(x) = \frac{1}{x-3}$

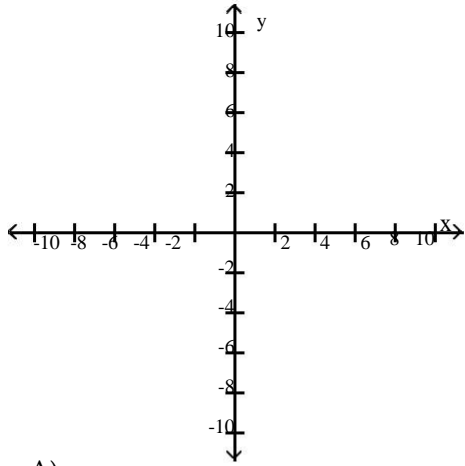

A)

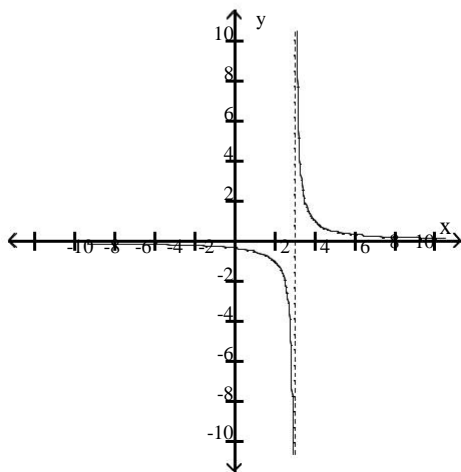

C)

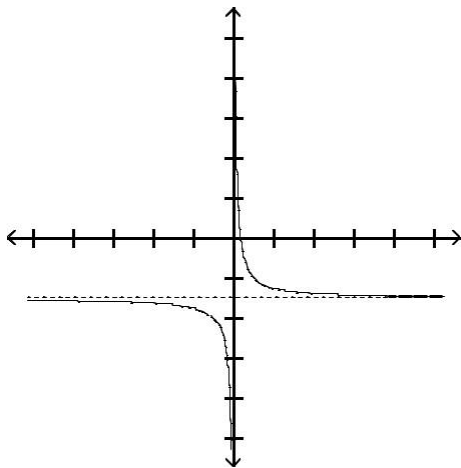

B)

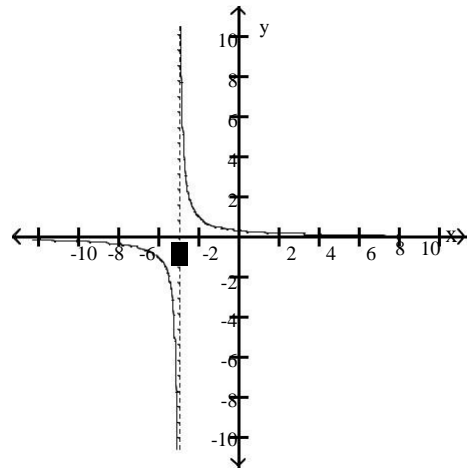

D)

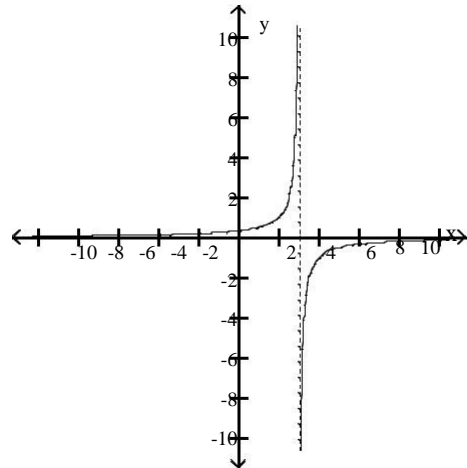

$$f(x) = \frac{1}{1+2x}$$

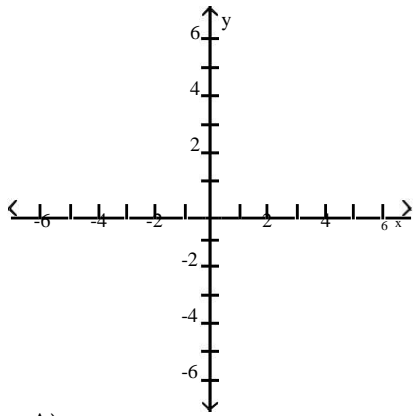

A)

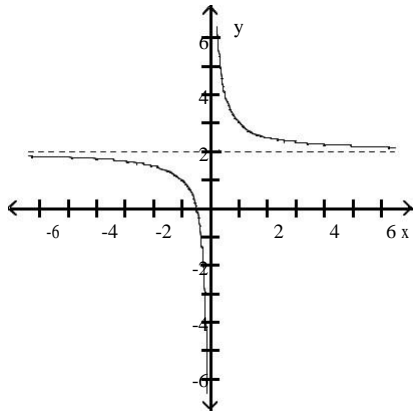

B)

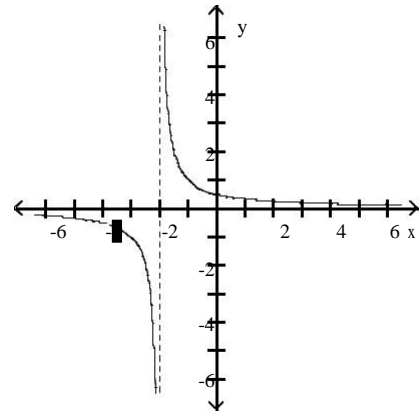

C)

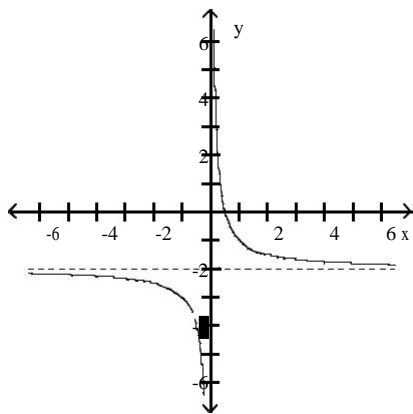

D)

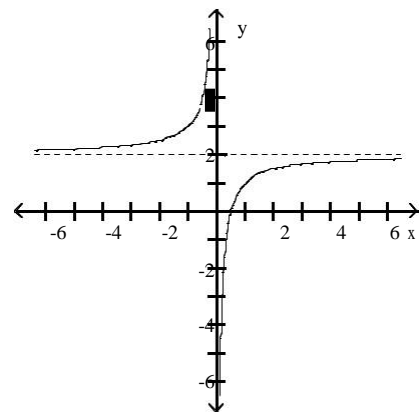

3)  $f(x) = \frac{1}{x+2} + 4$

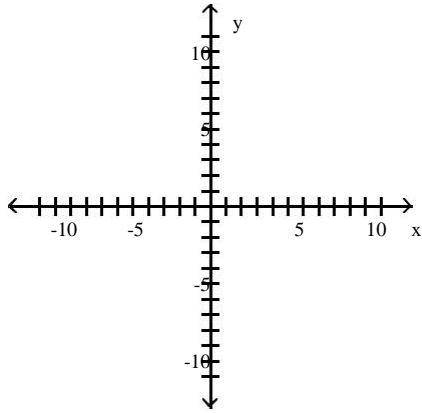

A)

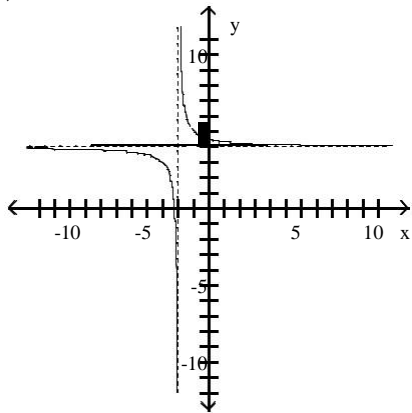

B)

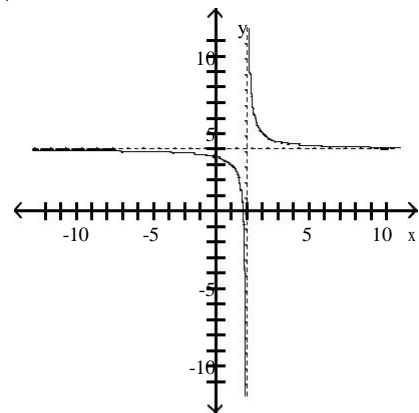

C)

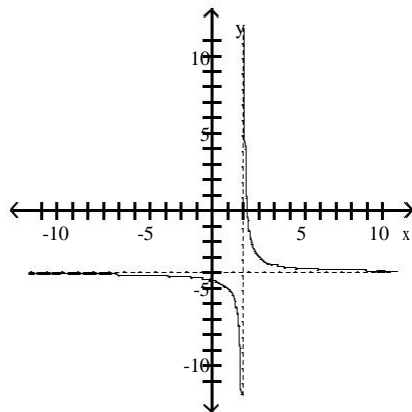

D)

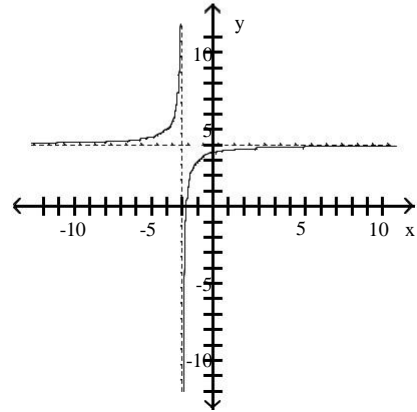

$$4) f(x) = \frac{1}{(x+5)^2}$$

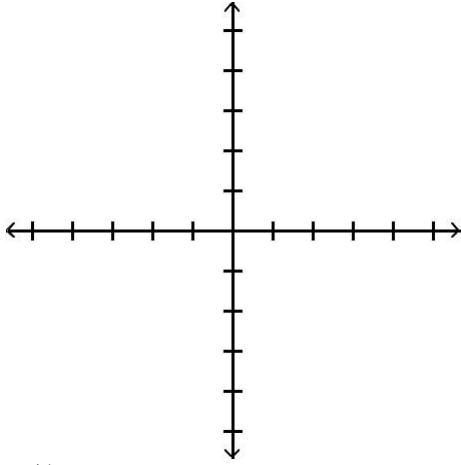

A)

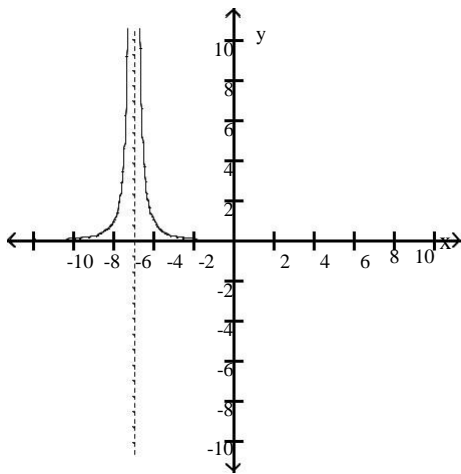

B)

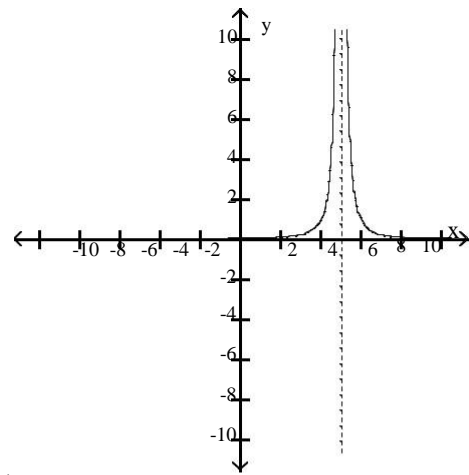

C)

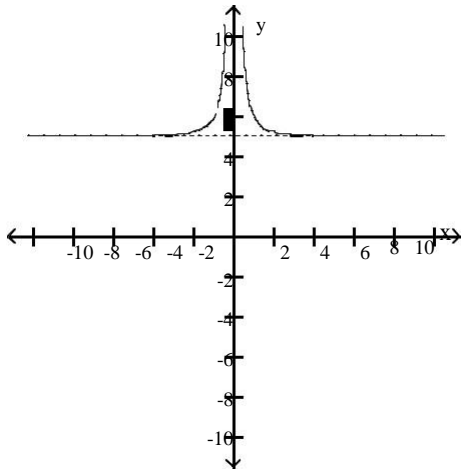

D)

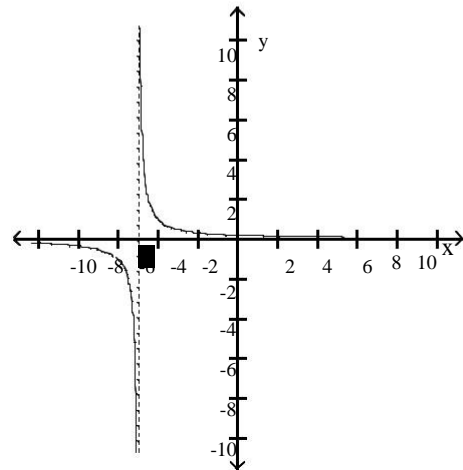

$$f(x) = \frac{1}{-2x^2}$$

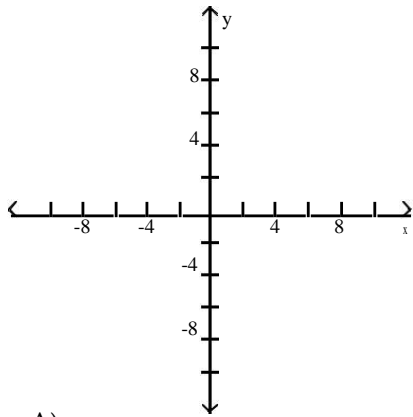

A)

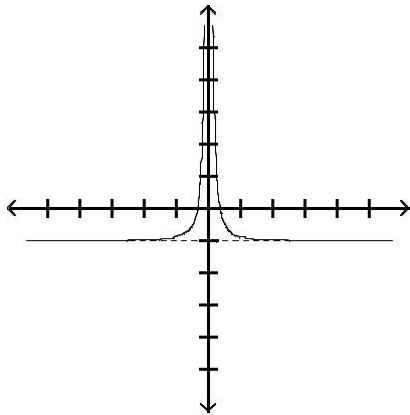

C)

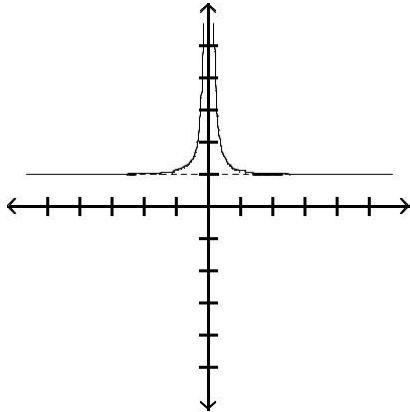

B)

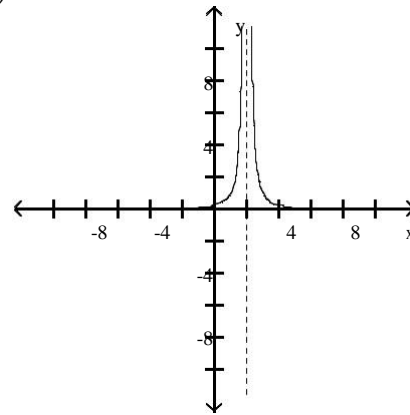

D)

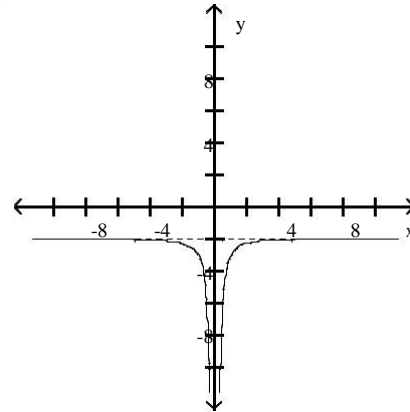

$$6) f(x) = -\frac{1}{(x+5)^2} + 4$$

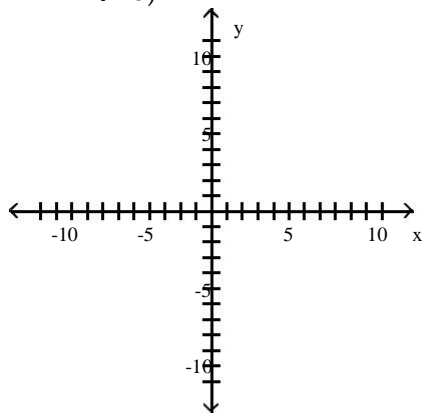

A)

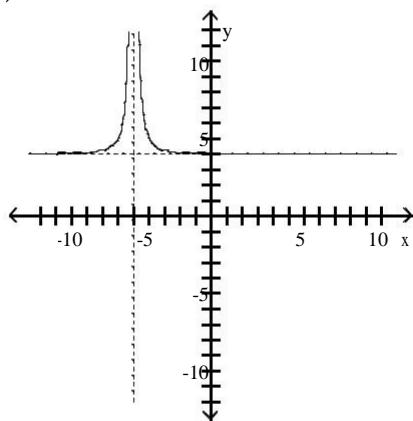

B)

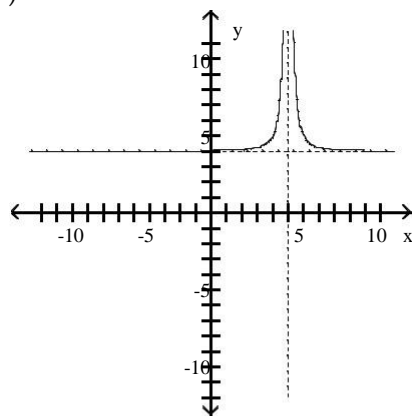

C)

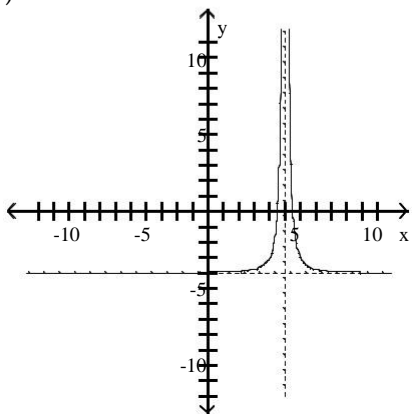

D)

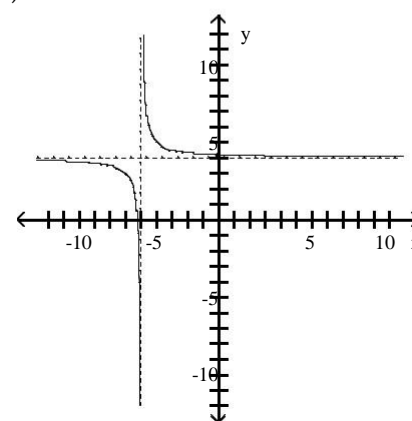

## 6 Graph Rational Functions

**MULTIPLE CHOICE.** Choose the one alternative that best completes the statement or answers the question.

Graph the rational function.

$$f(x) = \frac{2x}{x + 1}$$

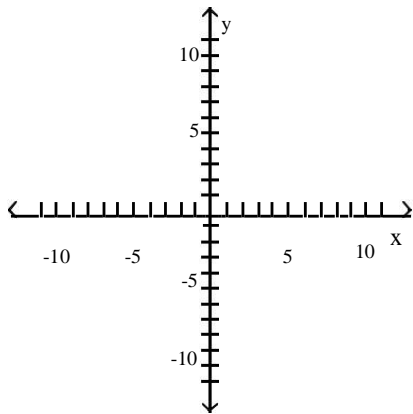

A)

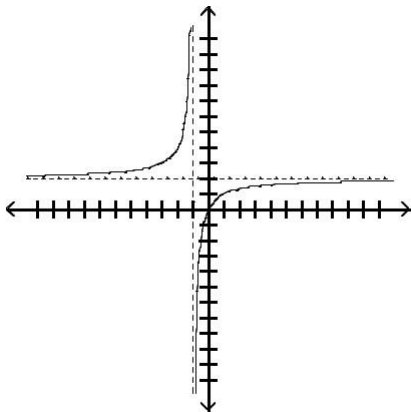

C)

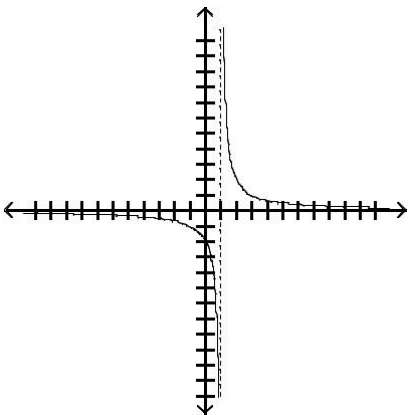

B)

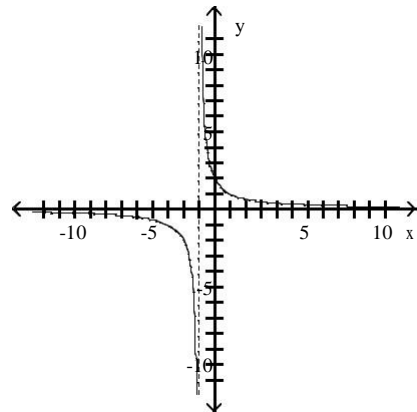

D)

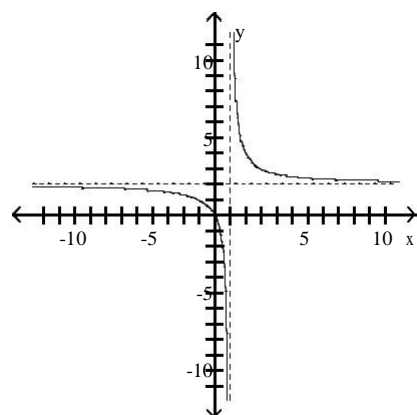

$$2) f(x) = \frac{3x}{x^2 - 4}$$

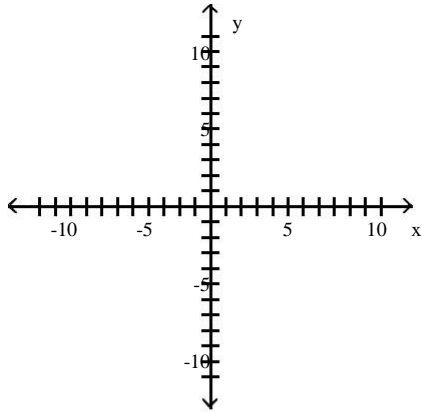

A)

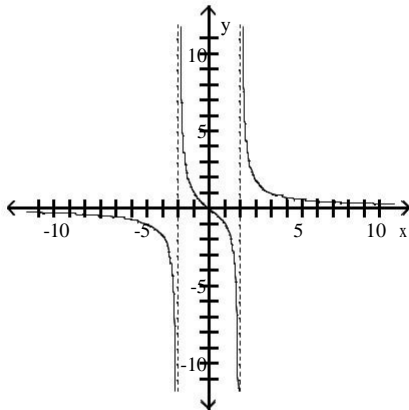

B)

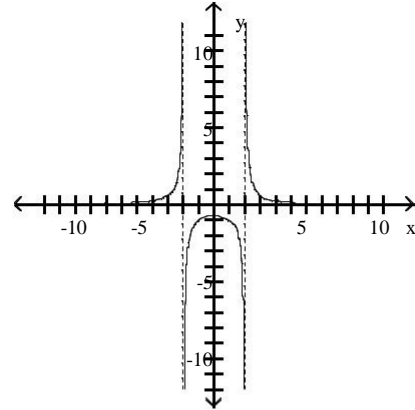

C)

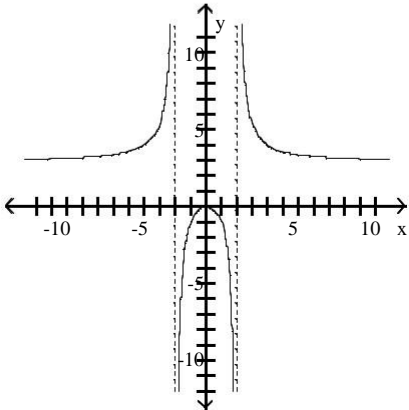

D)

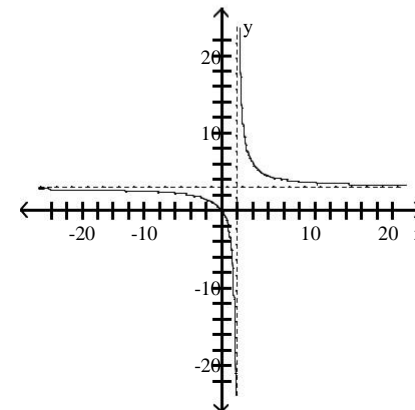



$$3) f(x) = -\frac{3x^2}{x^2 - 1}$$

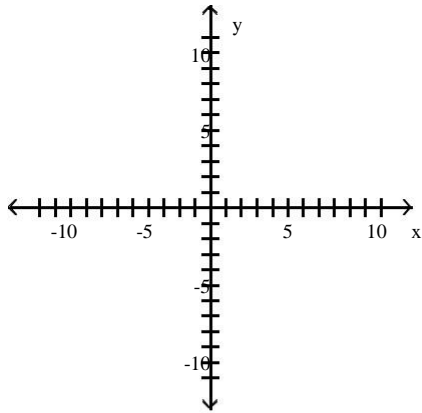

A)

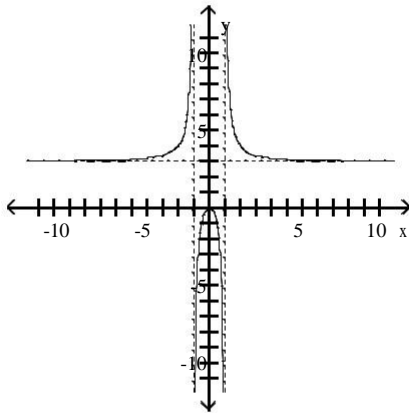

B)

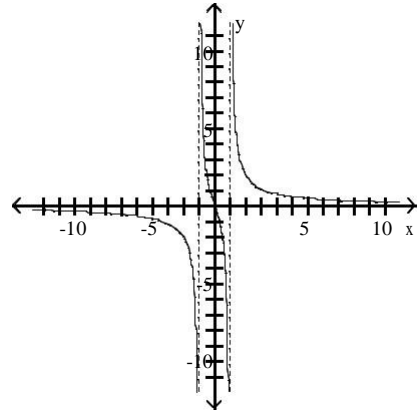

C)

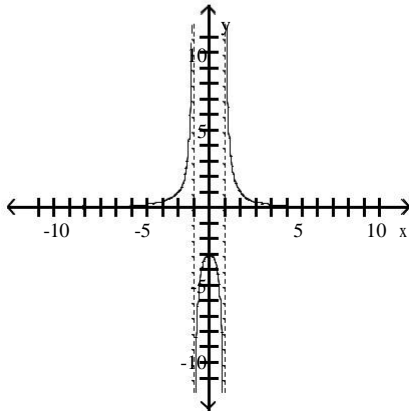

D)

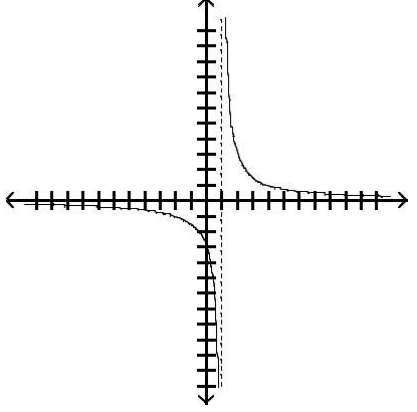

$$4) f(x) = \frac{-4x}{x-2}$$

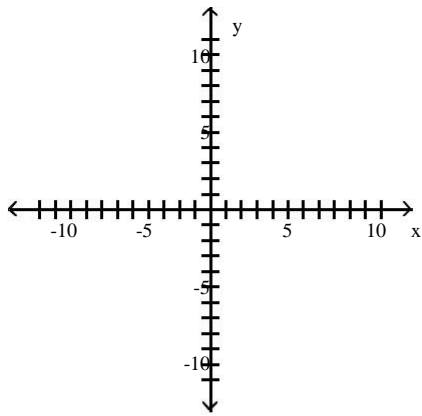

A)

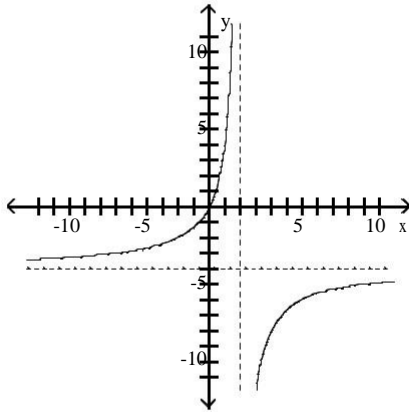

C)

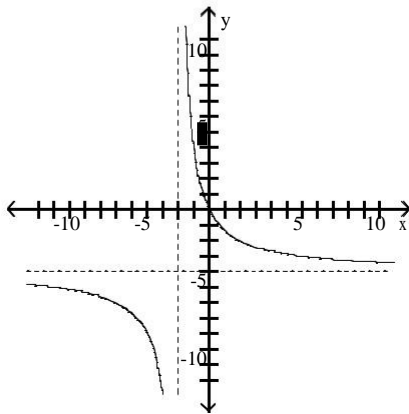

B)

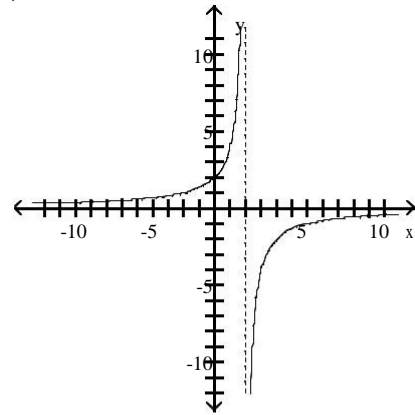

D)

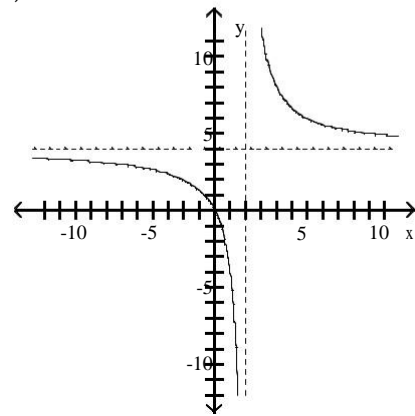

$$5) f(x) = -\frac{3}{x^2 - 9}$$

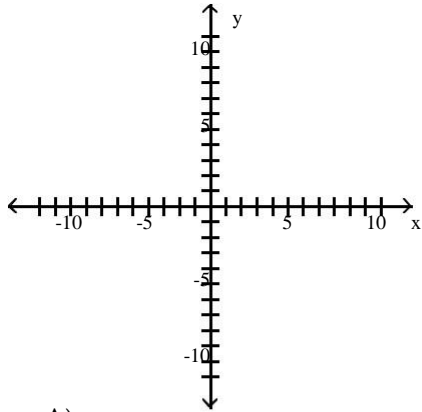

A)

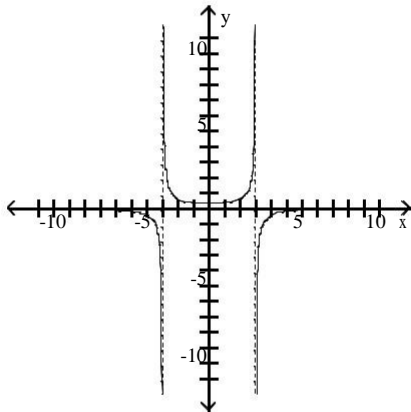

B)

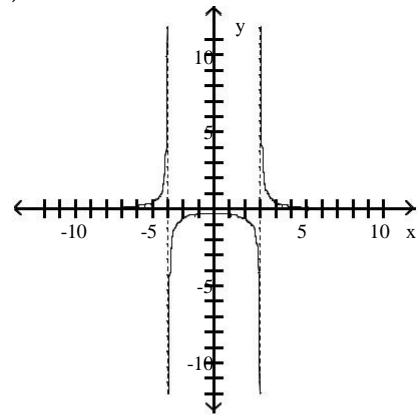

C)

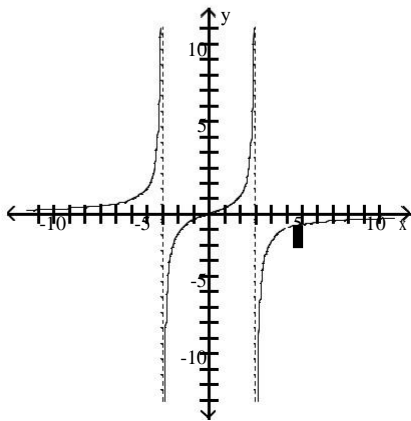

D)

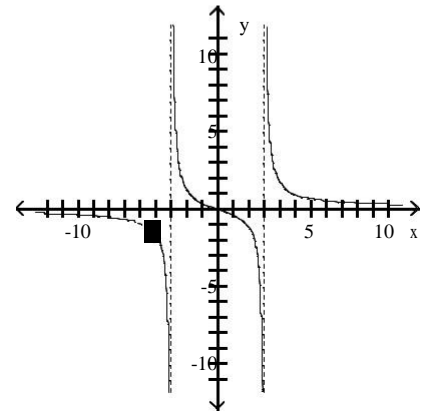

$$6) f(x) = \frac{5}{x^2 + 8x + 16}$$

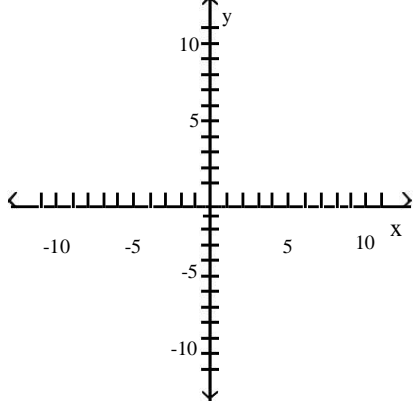

A)

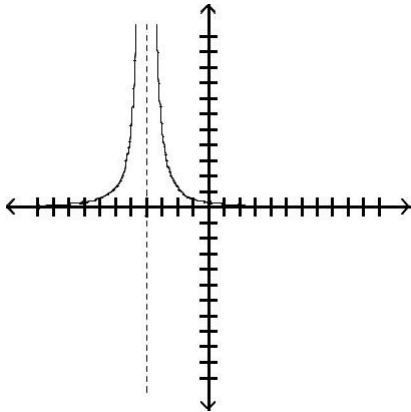

B)

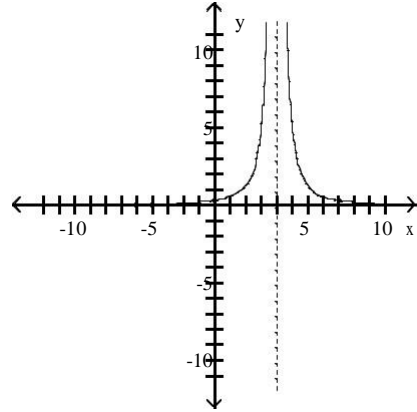

C)

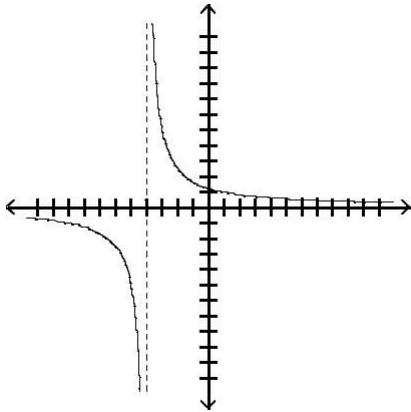

D)

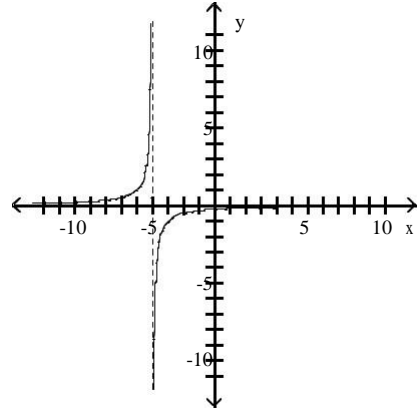

$$7) f(x) = -\frac{3x^2}{x^2 + 16}$$

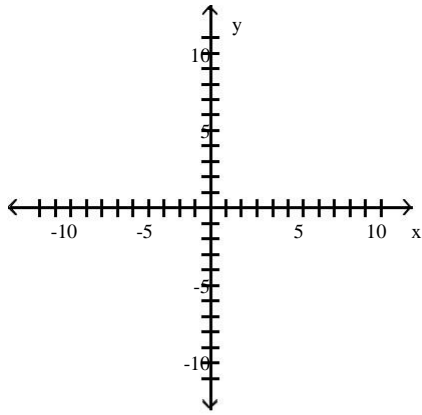

A)

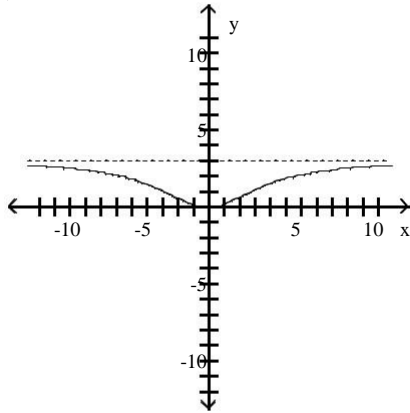

B)

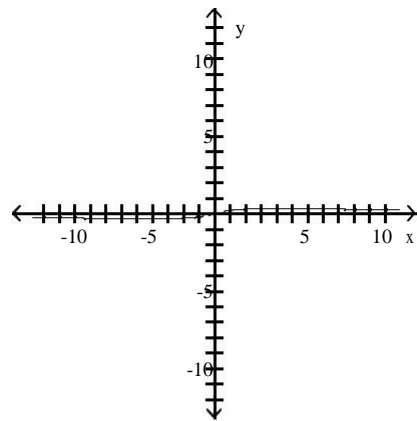

C)

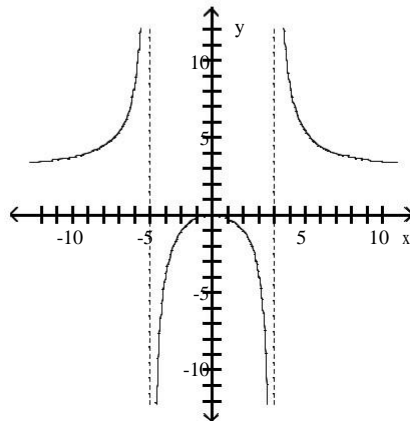

D)

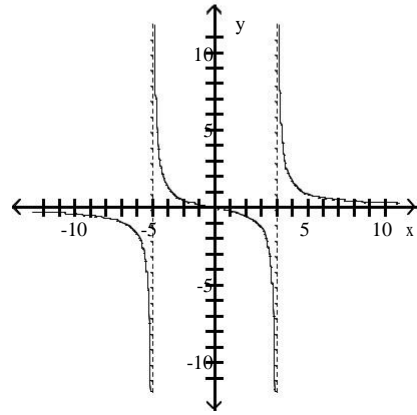

$$f(x) = \frac{x^2 - 4x - 5}{x^2 - 4}$$

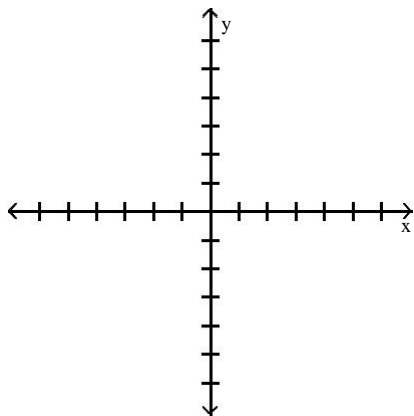

A)

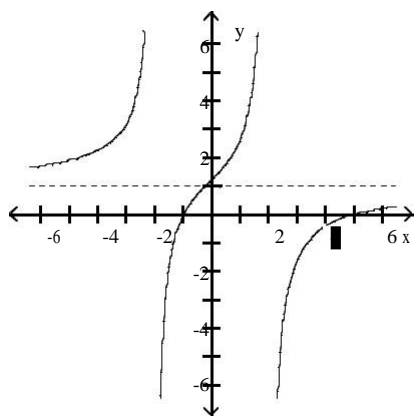

B)

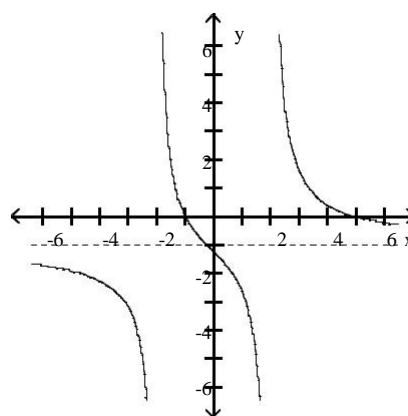

C)

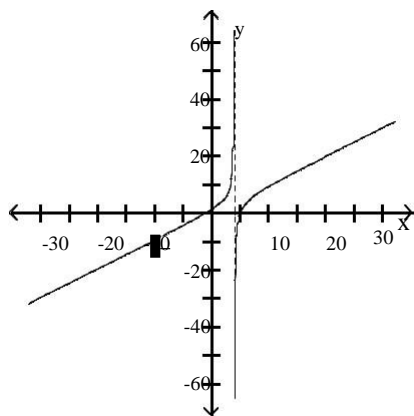

D)

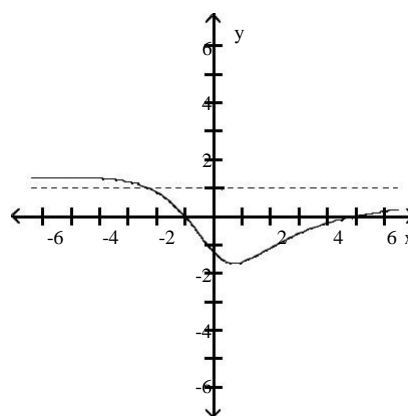

9)  $f(x) = \frac{x^4}{x^2 + 25}$

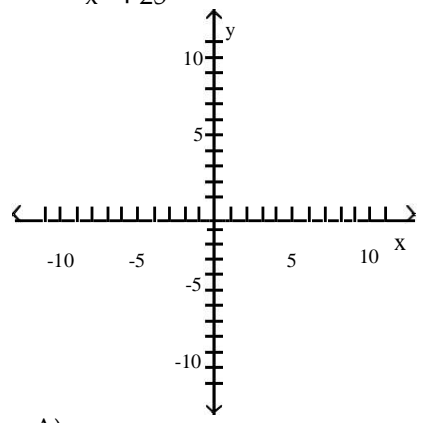

A)

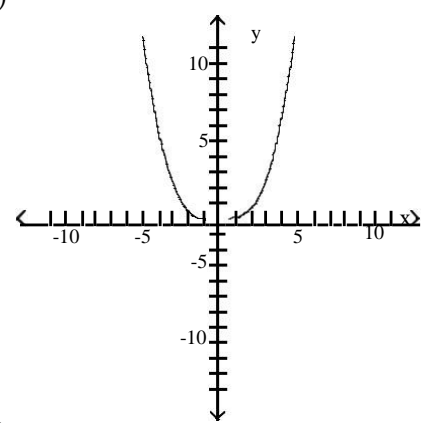

B)

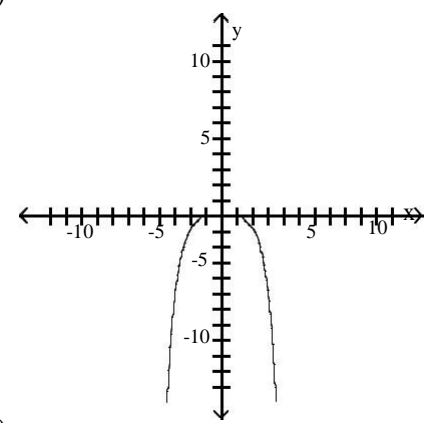

C)

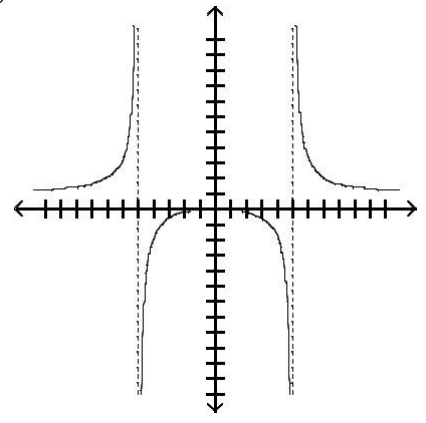

D)

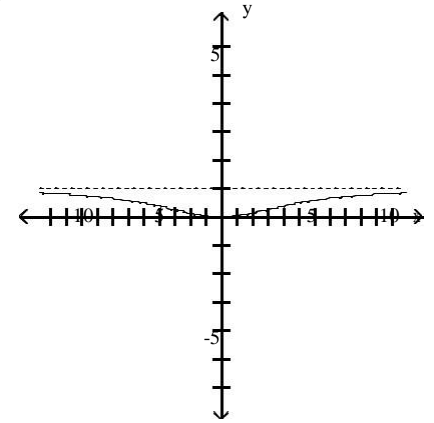

$$10) f(x) = \frac{x - 2}{x^2 - x - 42}$$

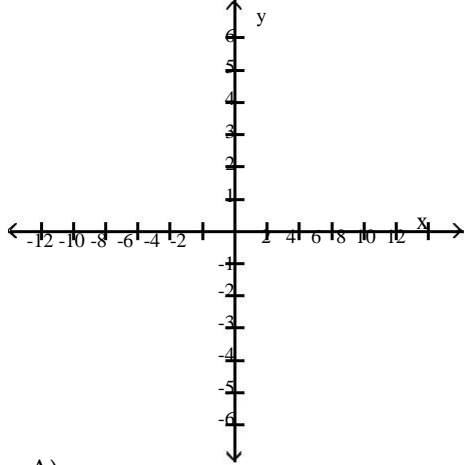

A)

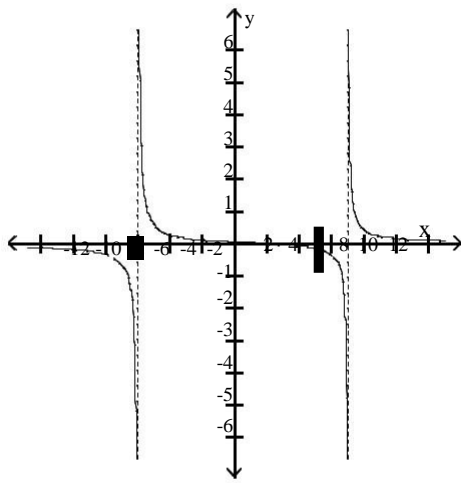

C)

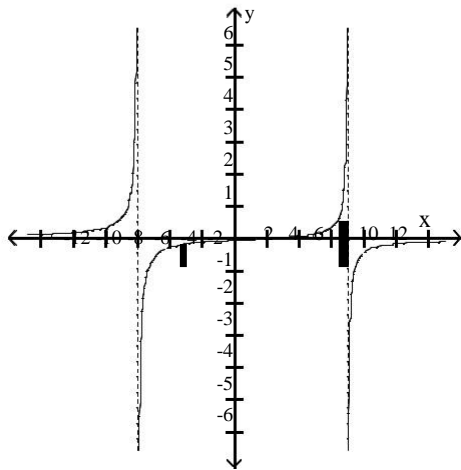

B)

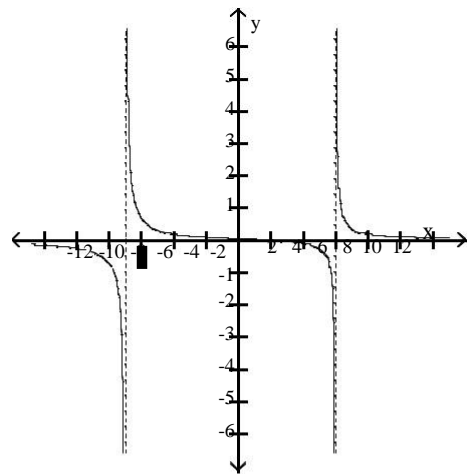

D)

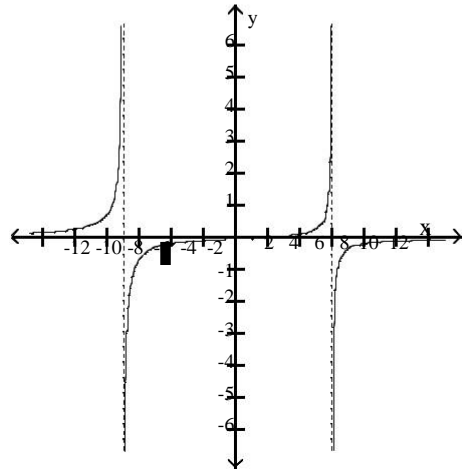



$$11) f(x) = \frac{x^2}{x^2 - x - 6}$$

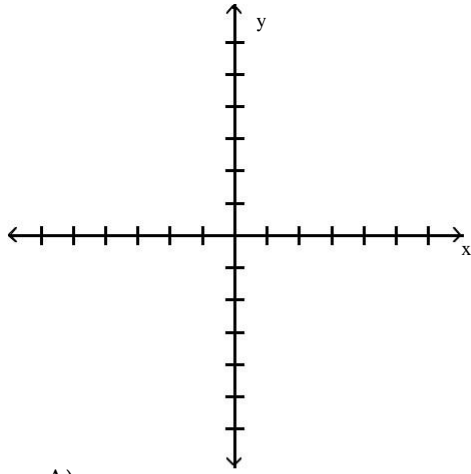

A)

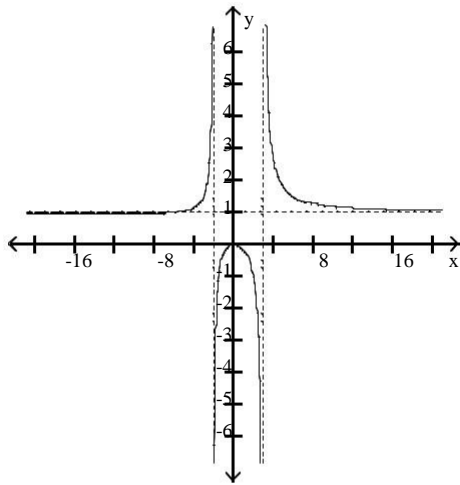

B)

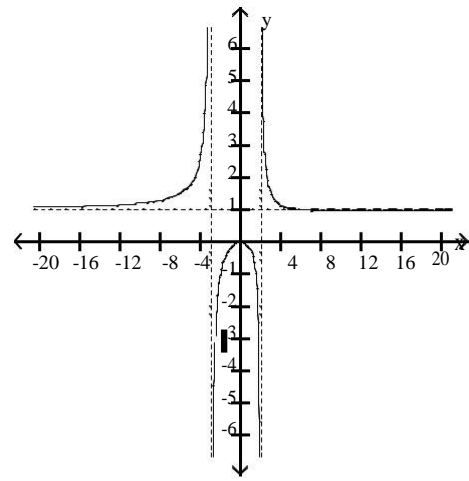

C)

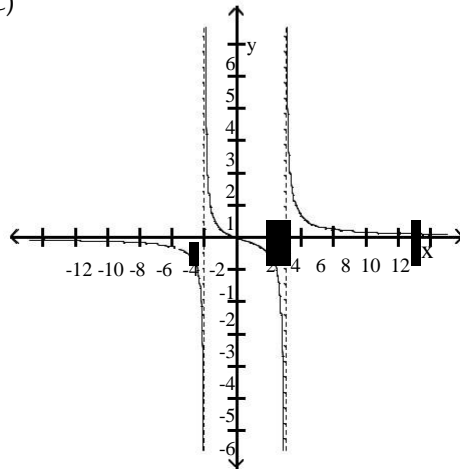

D)

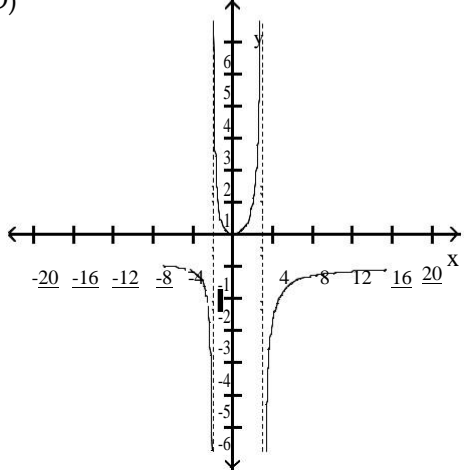

$$12) f(x) = \frac{x^2 - x - 56}{x^2 - 1}$$

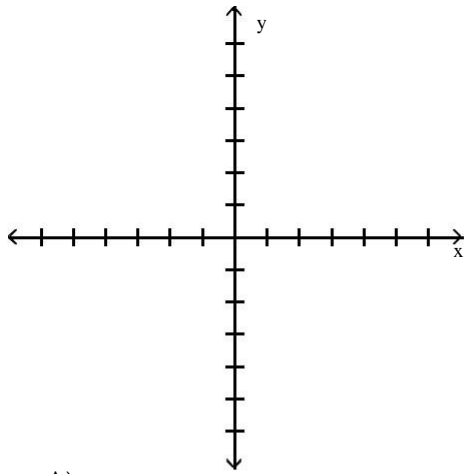

A)

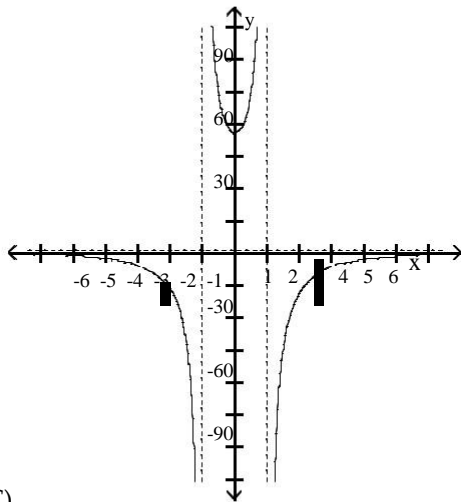

C)

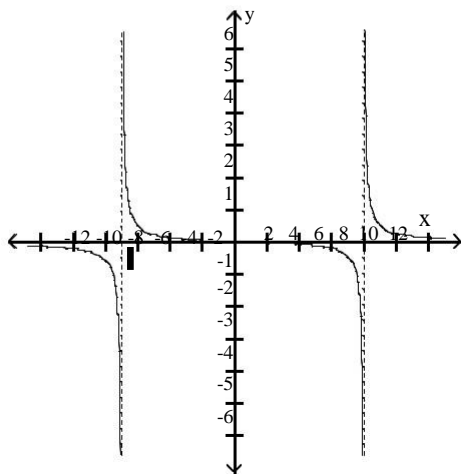

B)

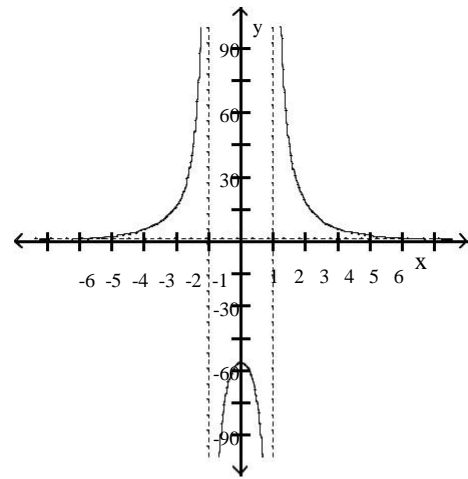

D)

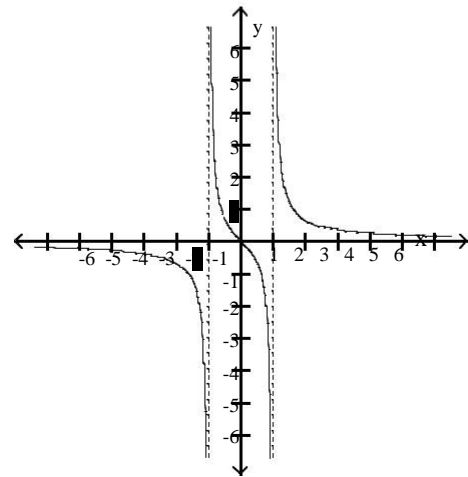

$$13) f(x) = \frac{x^2 - 4x}{(x-1)^2}$$

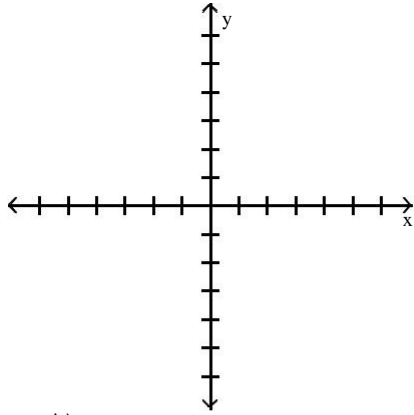

A)

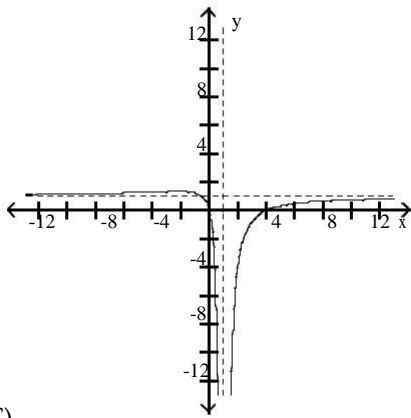

C)

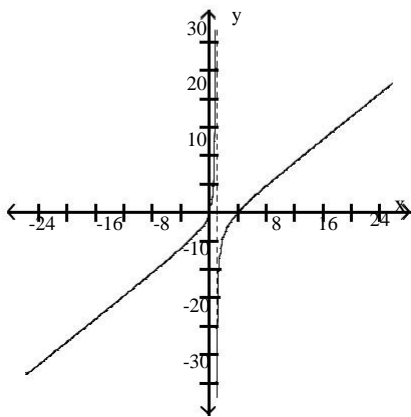

B)

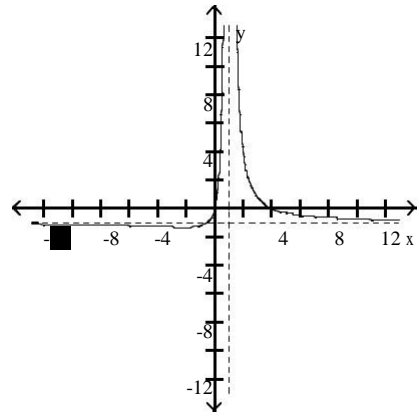

D)

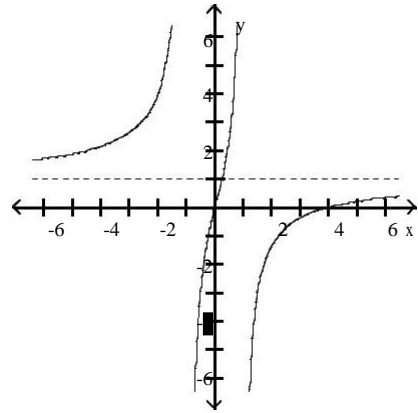

14)  $f(x) = \frac{x^2 - 8x + 15}{(x - 4)^2}$

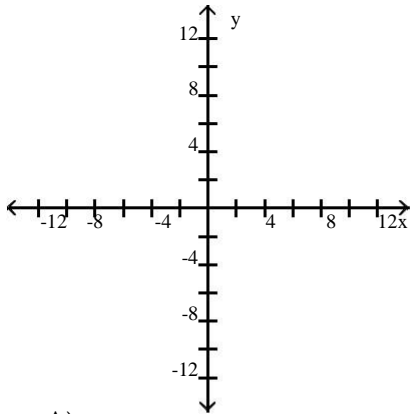

A)

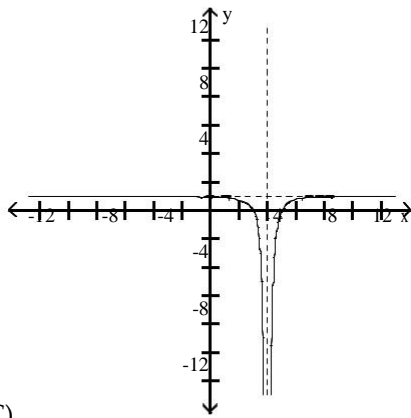

C)

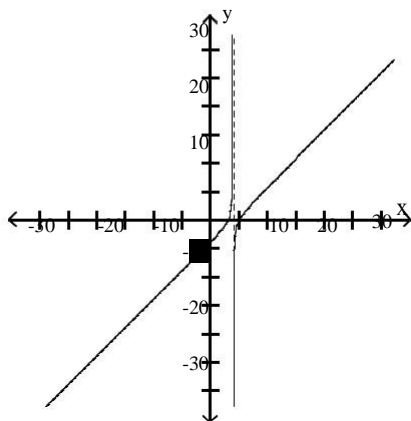

B)

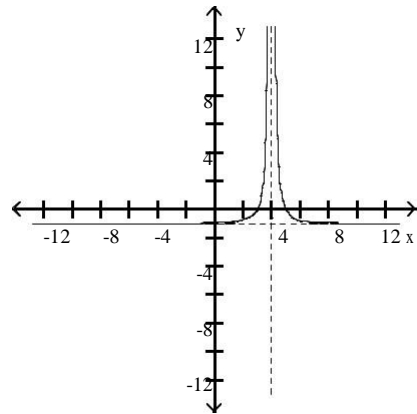

D)

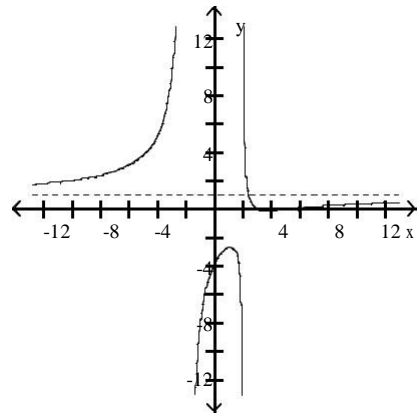

Find the indicated intercept(s) of the graph of the function.

15) x-intercepts of  $f(x) = \frac{x - 4}{x^2 + 3x - 2}$

A) (4, 0)

B) (2, 0)

C) (3, 0)

D) none

16) x-intercepts of  $f(x) = \frac{x^2 + 8}{x^2 + 5x + 3}$

A) (3, 0)

B)  $(\sqrt{8}, 0), (-8\sqrt{0})$

C) (8, 0)

D) none

17) x-intercepts of  $f(x) = \frac{x+3}{x^2+3x-2}$

A) (-3, 0)

B) (3, 0)

C)  $\left(\frac{3}{2}, 0\right)$

D) none

18) x-intercepts of  $f(x) = \frac{x^2+7x}{x^2+7x-3}$

A) (0, 0) and (-7, 0)

B) (-7, 0)

C) (0, 0) and (7, 0)

D) (7, 0)

19) x-intercepts of  $f(x) = \frac{(x-8)(2x+3)}{x^2+3x-4}$

A) (8, 0) and  $\left(-\frac{3}{2}, 0\right)$

B) (-8, 0) and  $\left(\frac{3}{2}, 0\right)$

C) (8, 0) and (-3, 0)

D) none

20) y-intercept of  $f(x) = \frac{x-8}{x^2+13x-10}$

A)  $\left(0, \frac{4}{5}\right)$

B) (0, 8)

C)  $\left(0, -\frac{5}{4}\right)$

D) none

21) y-intercept of  $f(x) = \frac{x^2-15x}{x^2+10x-14}$

A) (0, 0)

B)  $\left(0, \frac{15}{14}\right)$

C) (0, 15)

D)  $0, -\frac{14}{15}$

22) y-intercept of  $f(x) = \frac{-x^2-12}{x^2+15x-14}$

A)  $\left(0, \frac{6}{7}\right)$

B) (0, 12)

C)  $\left(0, -\frac{7}{6}\right)$

D) none

23) y-intercept of  $f(x) = \frac{x^2-3x+6}{8x}$

A)  $\left(0, \frac{3}{4}\right)$

B) (0, 6)

C)  $\left(0, -\frac{4}{3}\right)$

D) none

**Solve the problem.**

24) Is there y-axis symmetry for the rational function  $f(x) =$

A) Yes

$\frac{-4x^4-15}{-8x^3-18}$  ?  
B) No

25) Is there y-axis symmetry for the rational function  $f(x) =$

$\frac{8x^2}{-8x^3-18}$  ?

A) Yes

B) No

Is there y-axis symmetry for the rational function  $f(x) = \frac{5x^2 \pm 5x - 4}{7x + 1}$ ?

A) Yes

B) No

- 27) Is there origin symmetry for the rational function  $f(x) = \frac{4x}{-5x^2 + 1}$  ?  
 A) Yes B) No
- 28) Is there origin symmetry for the rational function  $f(x) = \frac{-2x^2 + 6}{4x}$  ?  
 A) Yes B) No
- 29) Is there origin symmetry for the rational function  $f(x) = \frac{6x^2 - 6}{4x^2 + 13}$  ?  
 A) Yes B) No

## 7 Identify Slant Asymptotes

**MULTIPLE CHOICE.** Choose the one alternative that best completes the statement or answers the question.

Find the slant asymptote, if any, of the graph of the rational function.

$$f(x) = \frac{x^2 - 9}{x}$$

- A)  $y = x$   
 C)  $x = 0$

- B)  $y = x - 9$   
 D) no slant asymptote

$$f(x) = \frac{x^2 + 6x - 4}{-4}$$

- A)  $y = x + 10$   
 C)  $y = x$

- B)  $y = x + 6$   
 D) no slant asymptote

$$3) f(x) = \frac{8x^2}{7x^2 + 3}$$

- A)  $y = 8x$   
 C)  $y = x + \frac{8}{7}$

- B)  $y = x + 8$   
 D) no slant asymptote

$$f(x) = \frac{x^2 - 8x + 9}{+4}$$

- A)  $y = x - 12$   
 C)  $x = y + 8$

- B)  $y = x + 17$   
 D) no slant asymptote

$$f(x) = \frac{x^3 + 6}{x^2 - 4}$$

- A)  $y = x$   
 C)  $y = x - 4$

- B)  $y = x + 6$   
 D) no slant asymptote

$$6) h(x) = \frac{x^3 - 4}{x^2 + 5x}$$

- A)  $y = x - 5$

- B)  $y = x + 5$

- C)  $y = x - 4$

- D)  $y = x$

Graph the function.

$$f(x) = \frac{x^2 + 16}{x}$$

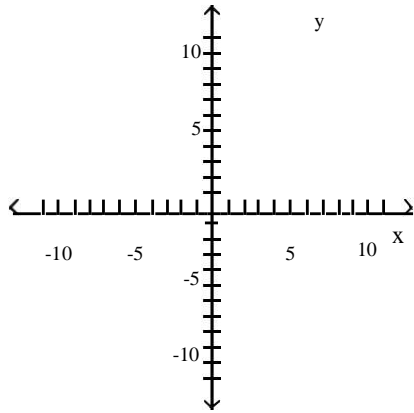

A)

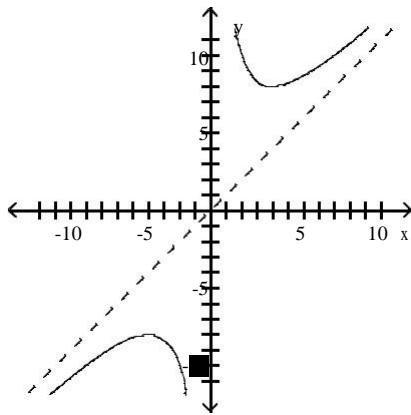

B)

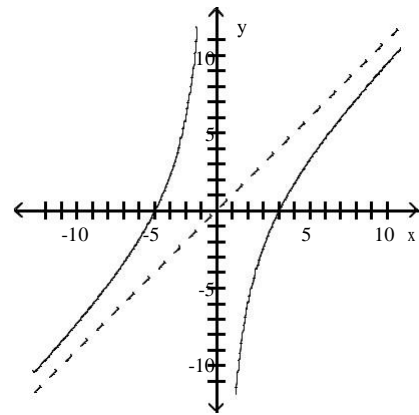

C)

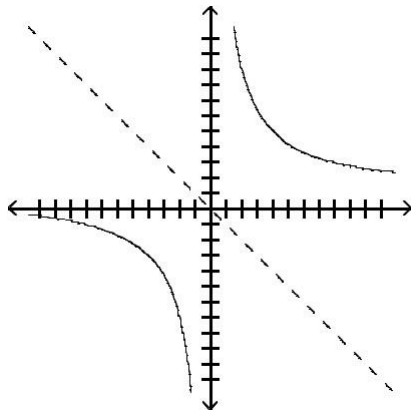

D)

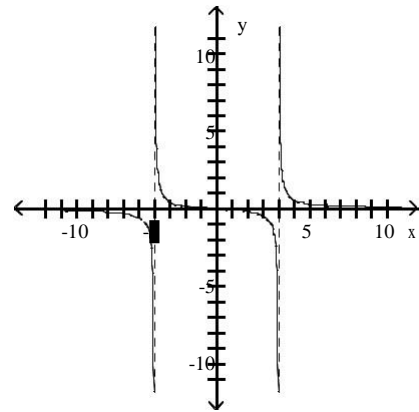



$$8) f(x) = \frac{x^2 + 5x - 3}{x - 8}$$

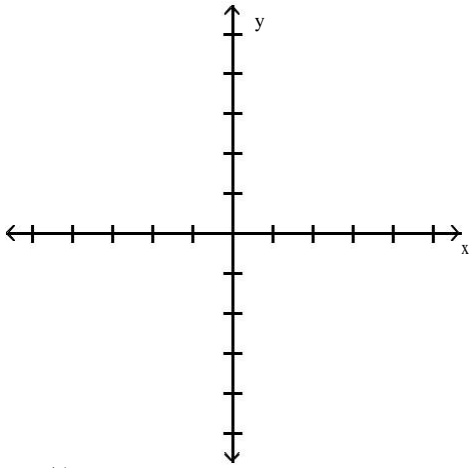

A)

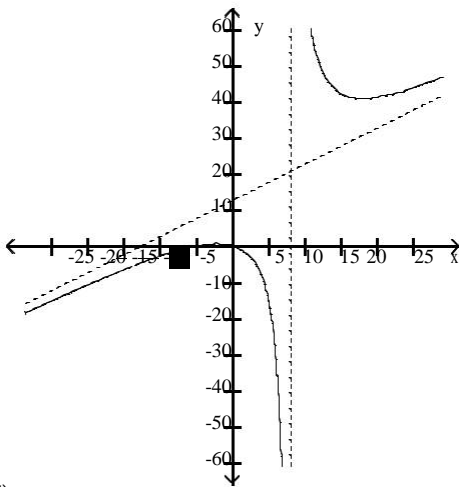

B)

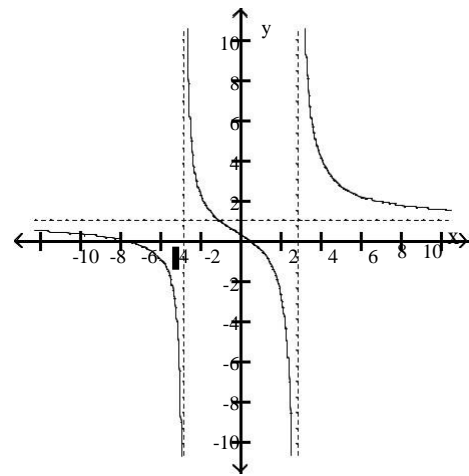

C)

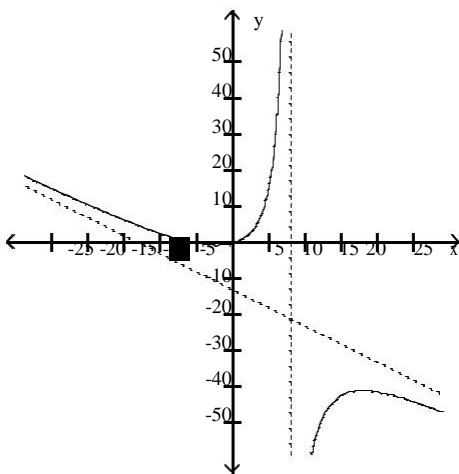

D)

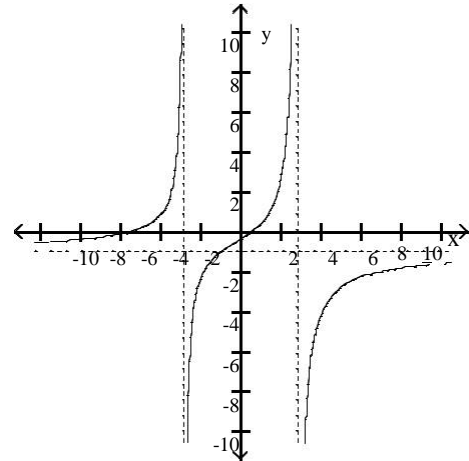

$$9) f(x) = \frac{x^3 + 4}{x^2 + 4x}$$

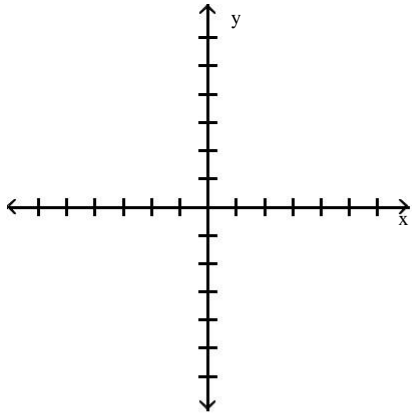

A)

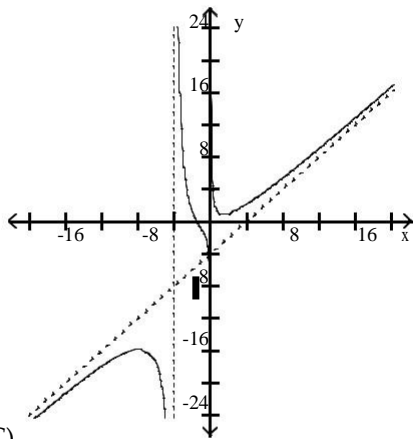

C)

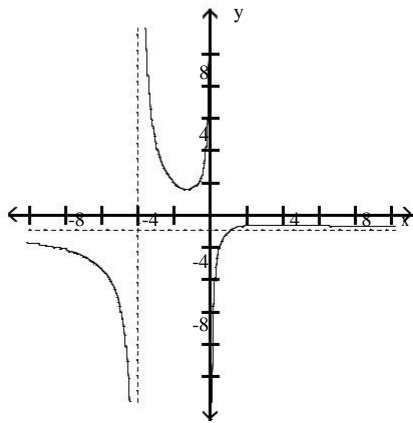

B)

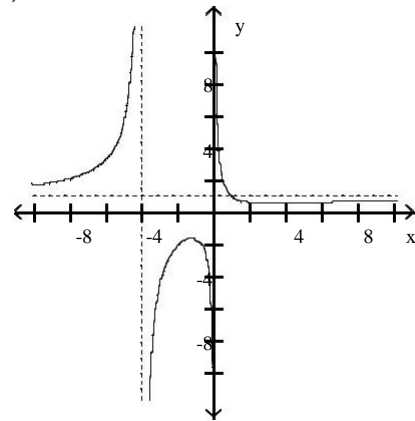

D)

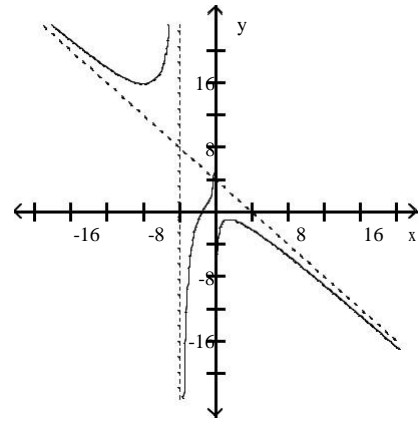

## 8 Solve Applied Problems Involving Rational Functions

**MULTIPLE CHOICE.** Choose the one alternative that best completes the statement or answers the question.

**Solve the problem.**

A company that produces bicycles has costs given by the function  $C(x) = 15x + 30,000$ , where  $x$  is the number of bicycles manufactured and  $C(x)$  is measured in dollars. The average cost to manufacture each bicycle is given by

$$\bar{C}(x) = \frac{15x + 30,000}{x}.$$

Find  $\bar{C}(250)$ . (Round to the nearest dollar, if necessary.)

A) \$135

B) \$125

C) \$27

D) \$28

A company that produces inflatable rafts has costs given by the function  $C(x) = 20x + 15,000$ , where  $x$  is the number of inflatable rafts manufactured and  $C(x)$  is measured in dollars. The average cost to manufacture each inflatable raft is given by

$$\bar{C}(x) = \frac{20x + 15,000}{x}.$$

What is the horizontal asymptote for the function  $\bar{C}$ ? Describe what this means in practical terms.

$y = 20$ ; \$20 is the least possible cost for producing each inflatable raft.

$y = 15,000$ ; 15,000 is the maximum number of inflatable rafts the company can produce.

$y = 20$ ; 20 is the minimum number of inflatable rafts the company can produce.

$y = 15,000$ ; \$15,000 is the least possible cost for running the company.

A drug is injected into a patient and the concentration of the drug is monitored. The drug's concentration,  $C(t)$ , in milligrams after  $t$  hours is modeled by

$$C(t) = \frac{4t}{2t^2 + 1}.$$

What is the horizontal asymptote for this function? Describe what this means in practical terms.

$y = 0$ ; 0 is the final amount, in milligrams, of the drug that will be left in the patient's bloodstream.

$y = 2.00$ ; 2.00 is the final amount, in milligrams, of the drug that will be left in the patient's bloodstream.

$y = 1.33$ ; After 1.33 hours, the concentration of the drug is at its greatest.

$y = 2.00$ ; After 2.00 hours, the concentration of the drug is at its greatest.

A drug is injected into a patient and the concentration of the drug is monitored. The drug's concentration,  $C(t)$ , in milligrams per liter after  $t$  hours is modeled by

$$C(t) = \frac{6t}{t^2 + 4}.$$

Estimate the drug's concentration after 5 hours. (Round to the nearest hundredth.)

A) 0.56 milligrams per liter

B) 0.49 milligrams per liter

C) 2.14 milligrams per liter

D) 2.07 milligrams per liter

5) The rational function

$$C(x) = \frac{135x}{100 - x}, 0 \leq x < 100$$

describes the cost,  $C$ , in millions of dollars, to inoculate  $x\%$  of the population against a particular strain of the flu. Determine the difference in cost between inoculating 80% of the population and inoculating 50% of the population. (Round to the nearest tenth, if necessary.)

- A) \$405.0 million      B) \$1.0 million      C) \$404.9 million      D) \$1.1 million

**Write a rational function that models the problem's conditions.**

A plane flies a distance of 1790 miles in still air. The next day, the plane makes the return trip, however due to a tailwind, the average velocity on the return trip is 29 miles per hour faster than the average velocity on the outgoing trip. Express the total time required to complete the round trip,  $T$ , as a function of the average velocity on the outgoing trip,  $x$ .

A)  $T(x) = \frac{1790}{x} + \frac{1790}{x + 29}$

B)  $T(x) = \frac{1790}{x} + \frac{1790}{x - 29}$

C)  $T(x) = \frac{x}{1790} + \frac{x + 29}{1790}$

D)  $T(x) = 1790x + 1790(x + 29)$

An athlete is training for a triathlon. One morning she runs a distance of 7 miles and cycles a distance of 35 miles. Her average velocity cycling is three times that while running. Express the total time for running and cycling,  $T$ , as a function of the average velocity while running,  $x$ .

A)  $T(x) = \frac{7}{x} + \frac{35}{3x}$

B)  $T(x) = \frac{7}{x} + \frac{35}{x + 3}$

C)  $T(x) = \frac{x}{7} + \frac{3x}{35}$

D)  $T(x) = \frac{35}{x} + \frac{7}{3x}$

The area of a rectangular rug is 250 square feet. Express the perimeter of the rug,  $P$ , as a function of the length of the rug,  $x$ .

A)  $P(x) = 2x + \frac{500}{x}$

B)  $P(x) = 2x + \frac{250}{x}$

C)  $P(x) = 2x + \frac{x}{500}$

D)  $P(x) = x(250 - x)$

The area of a rectangular photograph is 68 square inches. It is to be mounted on a rectangular card with a border of 1 inch at each side, 2 inches at the top, and 2 inches at the bottom. Express the total area of the photograph and the border,  $A$ , as a function of the width of the photograph,  $x$ .

A)  $A(x) = 76 + 4x + \frac{130}{x}$

B)  $A(x) = 7$

$2 + 4x + \frac{20}{x}$

C)  $A(x) = 76 + 2x + \frac{272}{x}$

D)  $A(x) = 7$

$6 + 4x + \frac{x}{36}$

## 2.7 Polynomial and Rational Inequalities

### 1 Solve Polynomial Inequalities

**MULTIPLE CHOICE.** Choose the one alternative that best completes the statement or answers the question.

Solve the polynomial inequality and graph the solution set on a number line. Express the solution set in interval notation.

1)  $(x - 2)(x + 8) > 0$

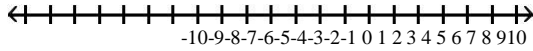

A)  $(-\infty, -8) \cup (2, \infty)$

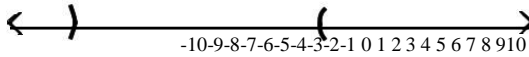

C)  $(-8, \infty)$

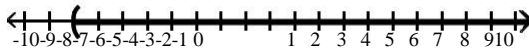

B)  $(-\infty, -2) \cup (8, \infty)$

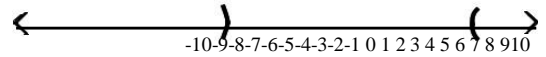

D)  $(-8, 2)$

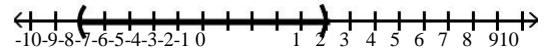

2)  $(x + 6)(x + 2) \leq 0$

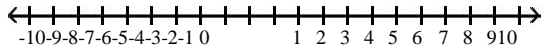

A)  $[-6, -2]$

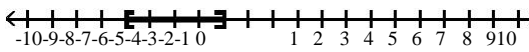

C)  $(-\infty, -6] \cup [-2, \infty)$

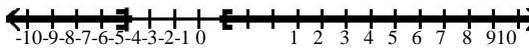

B)  $(-6, -2)$

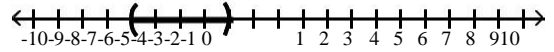

D)  $(-\infty, -6) \cup (-2, \infty)$

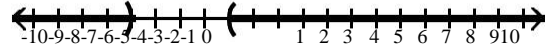

3)  $x^2 - 10x + 24 > 0$

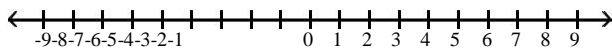

A)  $(-\infty, 4) \cup (6, \infty)$

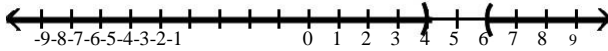

B)  $(4, 6)$

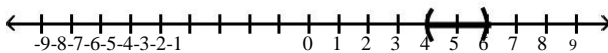

C)  $(-\infty, 4)$

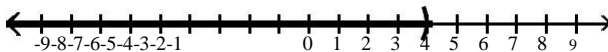

D)  $(6, \infty)$

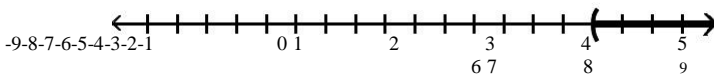

4)  $x^2 - 2x - 8 < 0$

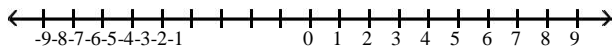

A)  $(-2, 4)$

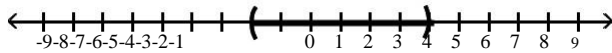

B)  $(-\infty, -2)$

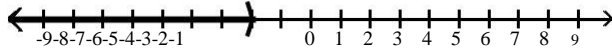

C)  $(4, \infty)$

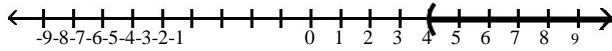

D)  $(-\infty, -2) \cup (4, \infty)$

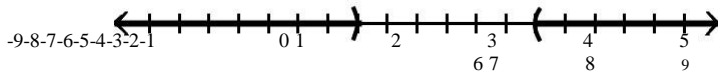

5)  $x^2 - 2x - 35 \leq 0$

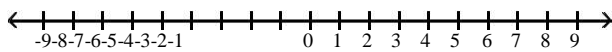

A)  $[-5, 7]$

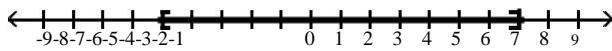

B)  $(-\infty, -5]$

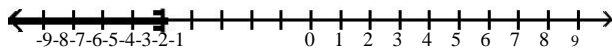

C)  $[7, \infty)$

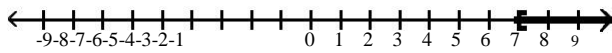

D)  $(-\infty, -5] \cup [7, \infty)$

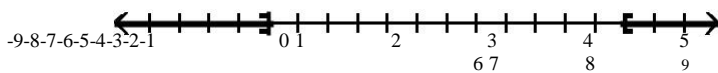

6)  $x^2 + 9x + 20 \geq 0$

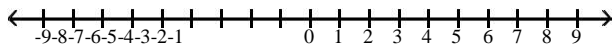

A)  $(-\infty, -5] \cup [-4, \infty)$

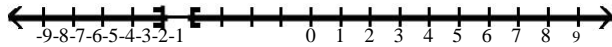

B)  $[-5, -4]$

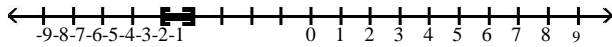

C)  $(-\infty, -5]$

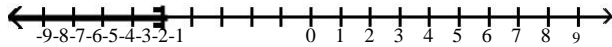

D)  $[-4, \infty)$

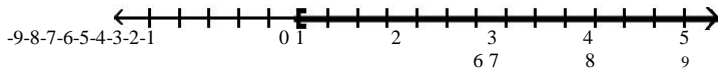

7)  $x^2 + 2x \leq 3$

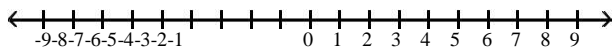

A)  $[-3, 1]$

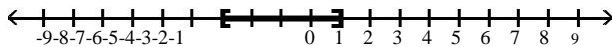

B)  $(-\infty, -1] \cup [3, \infty)$

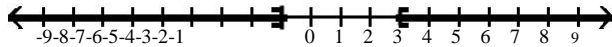

C)  $(-1, 3)$

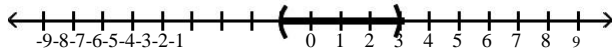

D)  $[-1, 3]$

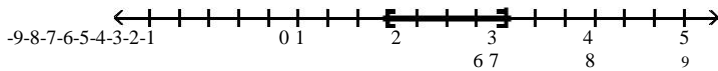

8)  $x^2 - 5x \geq -4$

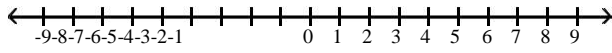

A)  $(-\infty, 1] \cup [4, \infty)$

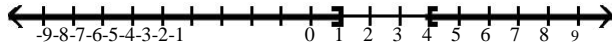

B)  $[1, 4]$

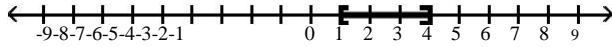

C)  $(-\infty, 1]$

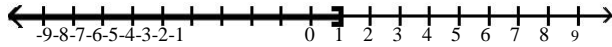

D)  $[4, \infty)$

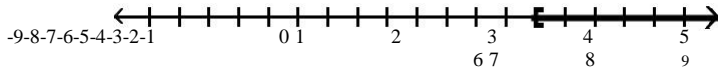

9)  $x^2 + 16x + 64 > 0$

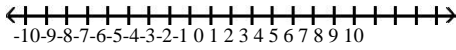

A)  $(-\infty, -8) \cup (-8, \infty)$



C)  $(-8, \infty)$

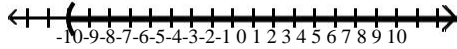

B)  $(-\infty, \infty)$

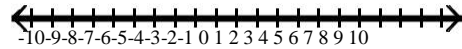

D)  $(-\infty, -8)$

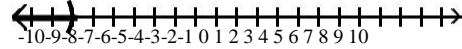

10)  $3x^2 + 14x - 5 \leq 0$

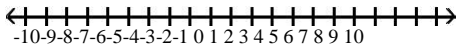

A)  $\left[-5, \frac{1}{3}\right]$

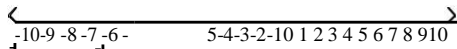

C)  $\left[-\infty, \frac{1}{3}\right]$

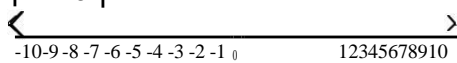

B)  $(-\infty, -5] \cup \left[\frac{1}{3}, \infty\right)$

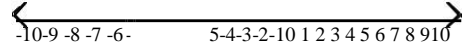

D)  $[-5, \infty)$

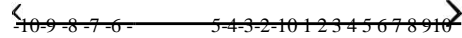



11)  $x^2 + 5x \geq 0$

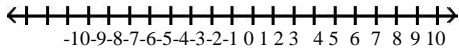

A)  $(-\infty, -5] \cup [0, \infty)$

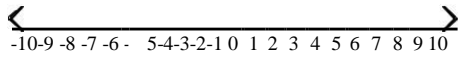

C)  $(-\infty, -5]$

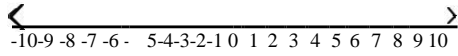

B)  $[-5, 0]$

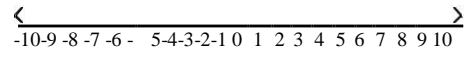

D)  $[0, \infty)$

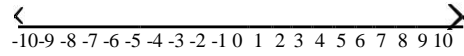

$9x^2 - 8x \leq 0$

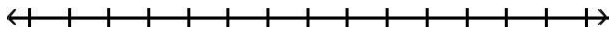

$\left[0, \frac{8}{9}\right]$

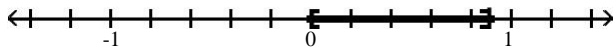

$(-\infty, 0] \cup \left[\frac{8}{9}, \infty\right)$



$\left[-\frac{8}{9}, 0\right]$



$\left[0, \frac{9}{8}\right]$



-7

-6

-5

-4

-3

13)  $(x + 3)(x - 4)(x - 7) > 0$

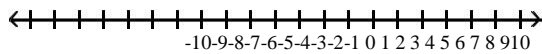

A)  $(-3, 4) \cup (7, \infty)$

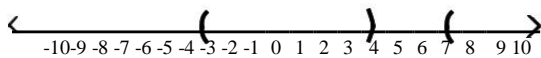

B)  $(-\infty, -3) \cup (4, 7)$

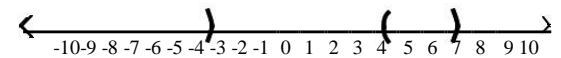

C)  $(7, \infty)$

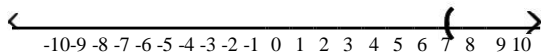

D)  $(-\infty, 4)$

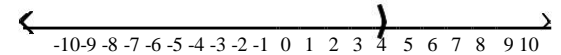

14)  $(x + 5)(x - 4)(x - 5) < 0$

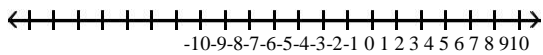

A)  $(-\infty, -5) \cup (4, 5)$

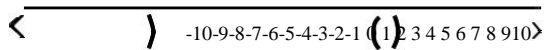

B)  $(5, \infty)$

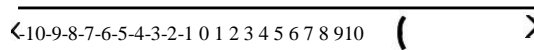

C)  $(-\infty, 4)$

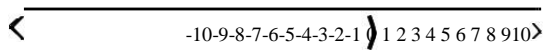

D)  $(-5, 4) \cup (5, \infty)$

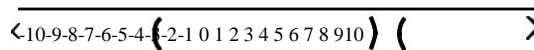

15)  $(2x - 3)(x + 4) \leq 0$

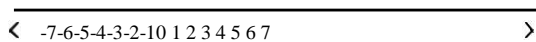

A)  $[-4, \frac{3}{2}]$

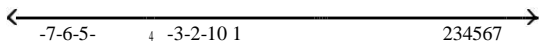

B)  $(-\infty, -4] \cup [\frac{3}{2}, \infty)$

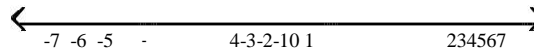

C)  $(-\infty, \frac{3}{2}]$

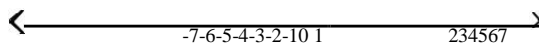

D)  $[-4, \infty)$

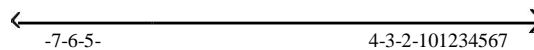

16)  $(2x + 9)(5x - 4) > 0$

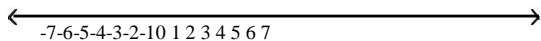

A)  $(-\infty, -\frac{9}{2}) \cup [\frac{4}{5}, \infty)$

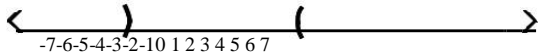

B)  $[\frac{4}{5}, \infty)$

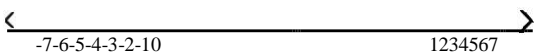

C)  $(\frac{9}{2}, \frac{4}{5})$

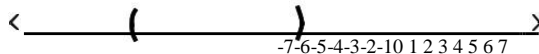

D)  $(-\frac{9}{2}, \frac{4}{5})$

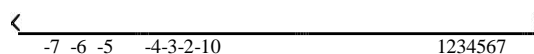

17)  $3x^2 - 5x \geq 8$

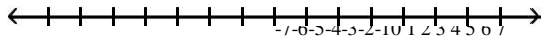

A)  $(-\infty, -1] \cup \left[\frac{8}{3}, \infty\right)$

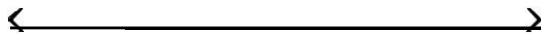

B)  $(-\infty, -1) \cup \left[\frac{8}{3}, \infty\right)$



-7  
4  
1  
6  
3

-6	(	-5	-
-3		-2	-
		0	1
		3	4
6	7	-7	-
-5		-4	-
		-2	-1
		0	1
		3	4
		6	7

C)  $\left[-1, \frac{8}{3}\right]$

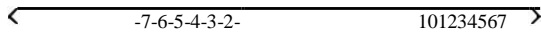

D)  $\left[-1, \frac{8}{3}\right)$

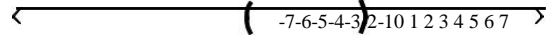

18)  $14x^2 < 13x + 1$

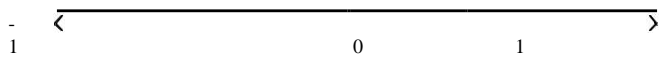

$\left[\frac{1}{14}, \frac{1}{14}\right)$

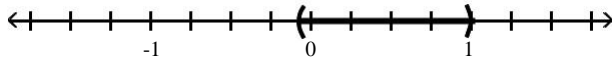

$\left[-\frac{1}{14}, \frac{1}{14}\right)$

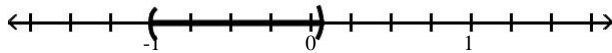

$(-\infty, -\frac{1}{14}) \cup (\frac{1}{14}, \infty)$

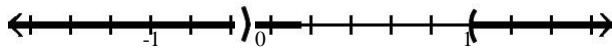

$(-\infty, -1) \cup \left[\frac{1}{14}, \infty\right)$

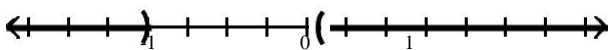



19)  $x < 42 - x^2$

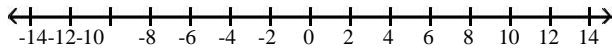

A)  $(-7, 6)$

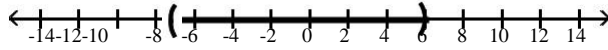

B)  $(-6, 7)$

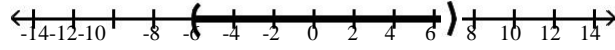

C)  $(-\infty, -7) \cup (6, \infty)$

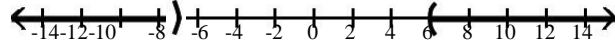

D)  $(-\infty, 6) \cup (7, \infty)$

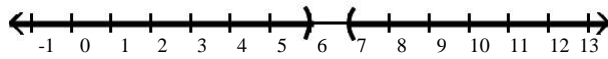

20)  $x^3 + 9x^2 - x - 9 > 0$

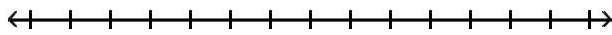

A)  $(-9, -1) \cup (1, \infty)$

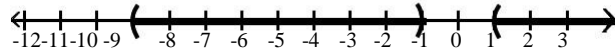

B)  $(-\infty, -9) \cup (-1, 1)$

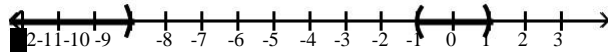

C)  $(-1, 1) \cup (9, \infty)$

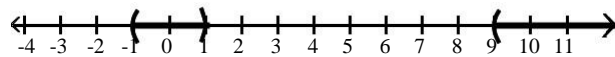

D)  $(-\infty, -1) \cup (1, 9)$

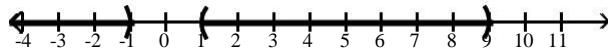

21)  $16x^3 + 64x^2 - 25x - 100 > 0$

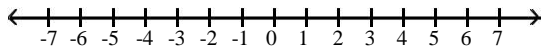

A)  $\left( -4, -\frac{5}{4} \right) \cup \left( \frac{5}{4}, \infty \right)$

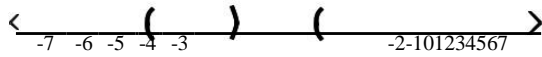

B)  $\left[ \frac{5}{4}, \infty \right)$

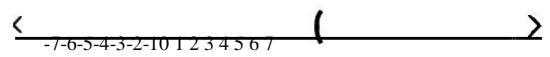

C)  $(-\infty, -4) \cup \left[ -\frac{5}{4}, \frac{5}{4} \right)$

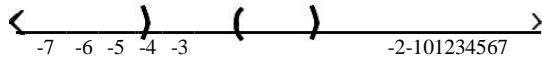

D)  $(-\infty, -4] \cup \left[ -\frac{5}{4}, \frac{5}{4} \right)$

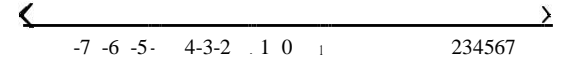

## 2 Solve Rational Inequalities

**MULTIPLE CHOICE.** Choose the one alternative that best completes the statement or answers the question.

Solve the rational inequality and graph the solution set on a real number line. Express the solution set in interval notation.

$$\frac{x-1}{x+8} < 0$$

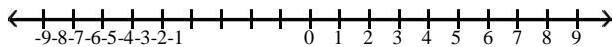

A)  $(-8, 1)$

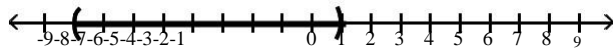

B)  $(-\infty, -8)$  or  $(1, \infty)$

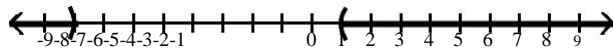

C)  $(1, \infty)$

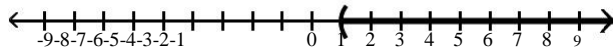

D)  $(-\infty, -8)$

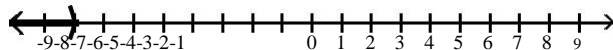

$$\frac{x-3}{x+6} > 0$$

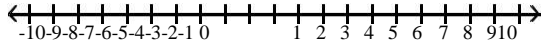

A)  $(-\infty, -6)$  or  $(3, \infty)$

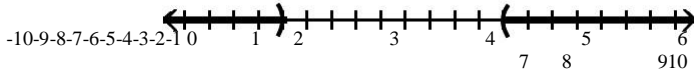

C)  $(3, \infty)$

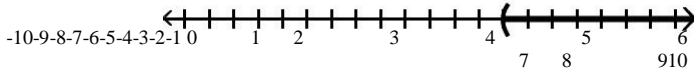

B)  $(-6, 3)$

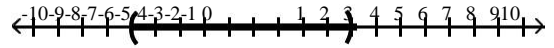

D)  $(-\infty, -6)$

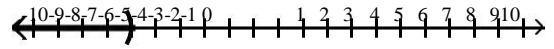

$$\frac{-x+5}{-4} \geq 0$$

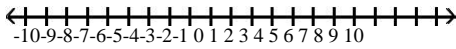

A)  $(4, 5]$

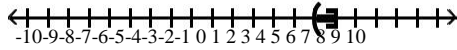

C)  $[4, 5]$

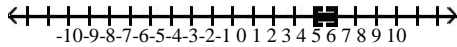

B)  $(-\infty, 4)$  or  $[5, \infty)$

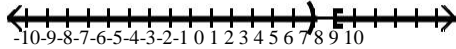

D)  $(-\infty, 5]$



$$\frac{-x-1}{+2} \leq 0$$

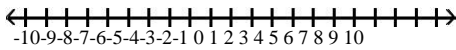

A)  $(-\infty, -2)$  or  $[-1, \infty)$



C)  $(-\infty, -2]$  or  $[-1, \infty)$

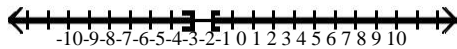

B)  $(-2, -1]$



D)  $[-1, \infty)$

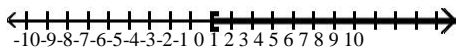

$$\frac{8-2x}{7x+8} \leq 0$$

$$7x+8$$

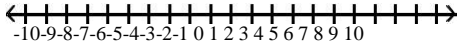

$$\left[-\infty, -\frac{8}{7}\right] \text{ or } [4, \infty)$$



$$\left[-\infty, -\frac{8}{7}\right] \text{ or } [4, \infty)$$



$$\left[-\frac{8}{7}, 4\right]$$

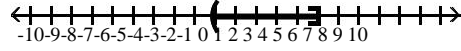

D)  $[4, \infty)$

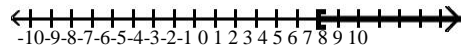

$$\frac{4x+3}{10-5x} \geq 0$$

$$10-5x$$

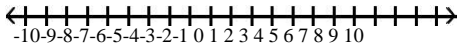

$$\left[-\frac{3}{4}, 2\right]$$



$$\left[-\frac{3}{4}, 2\right]$$

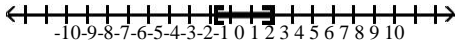

$$\left[-\infty, -\frac{3}{4}\right] \text{ or } (2, \infty)$$

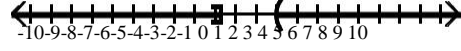

$$\left[-\frac{3}{4}, \infty\right)$$

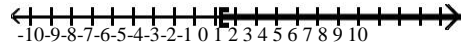

$$7) \frac{x}{x+5} > 0$$

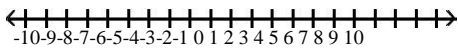

A)  $(-\infty, -5)$  or  $(0, \infty)$

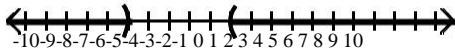

C)  $(-\infty, -5]$  or  $[0, \infty)$

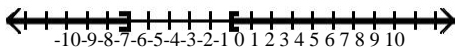

B)  $(-5, 0]$

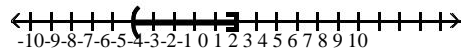

D)  $(0, \infty)$

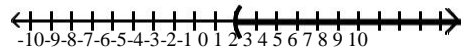



$$(x + 9)(x - 7) \geq 0$$

- 1

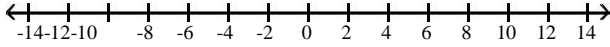

A)  $[-9, 1) \cup [7, \infty)$

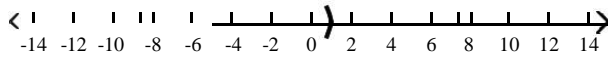

B)  $(-\infty, -9] \cup (1, 7]$

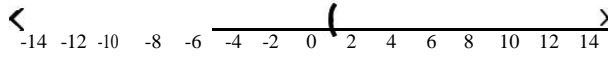

C)  $(-\infty, -9] \cup [7, \infty)$

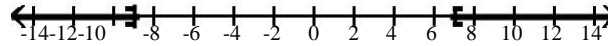

D)  $[-9, 1] \cup [7, \infty)$

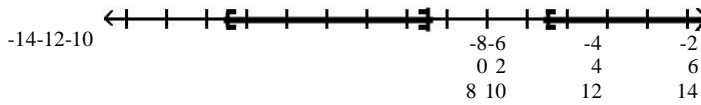

$$(x - 1)(3 - x) \leq 0$$

$$(x - 2)^2$$

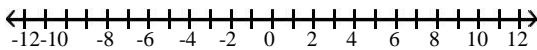

A)  $(-\infty, 1] \cup [3, \infty)$

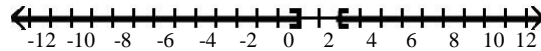

C)  $(-\infty, -3) \cup (-1, \infty)$

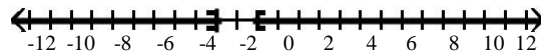

B)  $(-\infty, -3] \cup (-2, -1) \cup [1, \infty)$

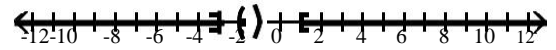

D)  $(-\infty, 1) \cup (3, \infty)$



$$10) \frac{x + 20}{x + 2} < 4$$

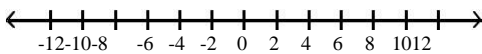

A)  $(-\infty, -2) \text{ or } (4, \infty)$

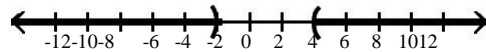

C)  $(-\infty, 4) \text{ or } (2, \infty)$

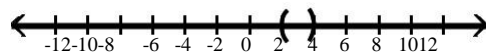

B)  $(-2, 4)$

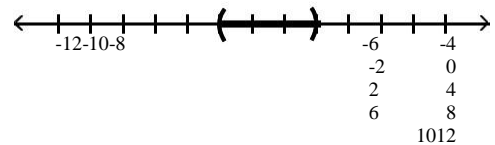

$\emptyset$

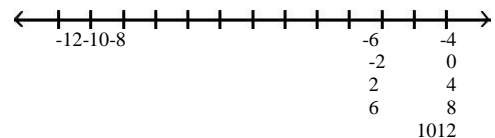



$$11) -\frac{2}{x-5} < 1$$

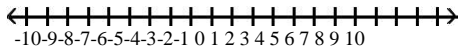

A)  $(-\infty, 5)$  or  $(7, \infty)$

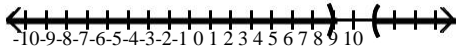

C)  $(-\infty, 5]$  or  $[7, \infty)$

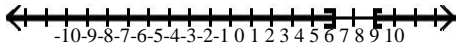

B)  $(5, 7)$

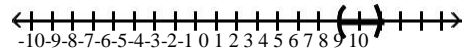

D)  $(-\infty, 5)$

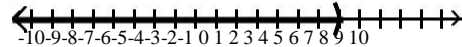

$$12) -\frac{x}{x+1} \geq 2$$

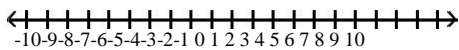

A)  $[-2, -1)$

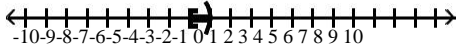

C)  $(-\infty, -1)$  or  $[0, \infty)$

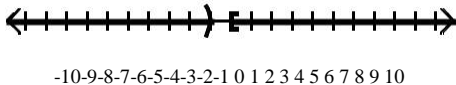

B)  $(-\infty, -2]$  or  $(-1, \infty)$

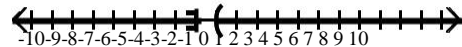

D)  $(-1, 2]$

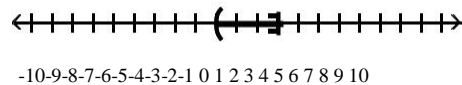

$$\frac{2x}{x+7} < x$$

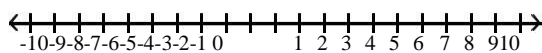

A)  $(-7, -5) \cup (0, \infty)$

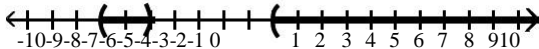

C)  $(-\infty, -7) \cup (0, \infty)$

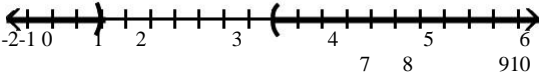

B)  $(-\infty, -7) \cup (-5, 0)$

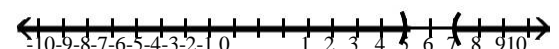

D)  $(-\infty, 5) \cup (7, \infty)$



### 3 Solve Problems Modeled by Polynomial or Rational Inequalities

**MULTIPLE CHOICE.** Choose the one alternative that best completes the statement or answers the question.

**Solve the problem.**

The average cost per unit,  $y$ , of producing  $x$  units of a product is modeled by  $y = \frac{900,000}{x} + 0.15x$ . Describe  $x$  the company's production level so that the average cost of producing each unit does not exceed \$4.65.

A) At least 200,000 units

B) Not more than 200,000 units

C) At least 300,000 units

D) Not more than 300,000 units



The total profit function  $P(x)$  for a company producing  $x$  thousand units is given by

$P(x) = -2x^2 + 34x - 120$ . Find the values of  $x$  for which the company makes a profit. [Hint: The company makes a profit when  $P(x) > 0$ .]

- x is between 5 thousand units and 12 thousand units
- x is greater than 5 thousand units
- x is less than 12 thousand units
- x is less than 5 thousand units or greater than 12 thousand units

A number minus the product of 36 and its reciprocal is less than zero. Find the numbers which satisfy this condition.

- A) any number less than -6 or between 0 and 6
- B) any number between 0 and 6
- C) any number between -6 and 6
- D) any number less than 6

The sum of 81 times a number and the reciprocal of the number is positive. Find the numbers which satisfy this condition.

- A) any number greater than 0
- B) any number greater than  $\frac{1}{9}$
- C) any number between  $-\frac{1}{9}$  and  $\frac{1}{9}$
- D) any number between 0 and  $\frac{1}{9}$

An arrow is fired straight up from the ground with an initial velocity of 208 feet per second. Its height,  $s(t)$ , in feet at any time  $t$  is given by the function  $s(t) = -16t^2 + 208t$ . Find the interval of time for which the height of the arrow is greater than 276 feet.

- A) between  $\frac{3}{2}$  and  $\frac{23}{2}$  sec
- B) after  $\frac{3}{2}$  sec
- C) before  $\frac{23}{2}$  sec
- D) before  $\frac{3}{2}$  sec or after  $\frac{23}{2}$  sec

6) A ball is thrown vertically upward with an initial velocity of 160 feet per second. The distance in feet of the ball from the ground after  $t$  seconds is  $s = 160t - 16t^2$ . For what interval of time is the ball more than 336 above the ground?

- A) between 3 and 7 seconds
- B) between 2.5 and 7.5 seconds
- C) between 8 and 12 seconds
- D) between 4.5 and 5.5 seconds

A ball is thrown vertically upward with an initial velocity of 192 feet per second. The distance in feet of the ball from the ground after  $t$  seconds is  $s = 192t - 16t^2$ . For what intervals of time is the ball less than 512 above the ground (after it is tossed until it returns to the ground)?

- between 0 and 4 seconds and between 8 and 12 seconds
- between 4 and 8 seconds
- between 0 and 3.5 seconds and between 8.5 and 12 seconds
- between 0 and 5.5 seconds and between 6.5 and 12 seconds

The revenue achieved by selling  $x$  graphing calculators is figured to be  $x(28 - 0.2x)$  dollars. The cost of each calculator is \$12. How many graphing calculators must be sold to make a profit (revenue - cost) of at least \$300.00?

- A) between 30 and 50 calculators
- B) between 10 and 30 calculators
- C) between 31 and 29 calculators
- D) between 32 and 48 calculators

The revenue achieved by selling  $x$  graphing calculators is figured to be  $x(37 - 0.5x)$  dollars. The cost of each calculator is \$13. How many graphing calculators must be sold to make a profit (revenue - cost) of at least \$283.50?

- A) between 21 and 27 calculators  
 B) between 27 and 33 calculators  
 C) between 22 and 26 calculators  
 D) between 23 and 25 calculators

You drive 111 miles along a scenic highway and then take a 32-mile bike ride. Your driving rate is 5 times your cycling rate. Suppose you have no more than a total of 7 hours for driving and cycling. Let  $x$  represent your cycling rate in miles per hour. Write a rational inequality that can be used to determine the possible values of  $x$ . Do not simplify and do not solve the inequality.

- A)  $\frac{111}{5x} + \frac{32}{x} \leq 7$   
 B)  $\frac{111}{x} + \frac{32}{5x} \leq 7$   
 C)  $\frac{5x}{111} + \frac{x}{32} \leq 7$   
 D)  $\frac{111}{5x} + \frac{32}{x} \geq 7$

You drive 125 miles along a scenic highway and then take a 20-mile bike ride. Your driving rate is 5 times your cycling rate. Suppose you have no more than a total of 5 hours for driving and cycling. Let  $x$  represent your cycling rate in miles per hour. Use a rational inequality to determine the possible values of  $x$ .

- A)  $x \geq 9$  mph  
 B)  $x \leq 9$  mph  
 C)  $x \geq 25.8$  mph  
 D)  $x \leq 55.6$  mph

The perimeter of a rectangle is 46 feet. Describe the possible lengths of a side if the area of the rectangle is to be greater than 120 square feet.

- The length of the rectangle must lie between 8 and 15 ft  
 The length of the rectangle must be greater than 15 ft  
 The length of the rectangle must be greater than 15 ft or less than 8 ft  
 The length of the rectangle must lie between 1 and 120 ft

## 2.8 Modeling Using Variation

### 1 Solve Direct Variation Problems

**MULTIPLE CHOICE.** Choose the one alternative that best completes the statement or answers the question.

**Write an equation that expresses the relationship. Use  $k$  as the constant of variation.**

1)  $a$  varies directly as  $m$ .

- A)  $a = km$   
 B)  $a = \frac{k}{m}$   
 C)  $k = am$   
 D)  $m = \frac{k}{a}$

2)  $a$  varies directly as the square of  $b$ .

- A)  $a = kb^2$   
 B)  $a = \frac{k}{b^2}$   
 C)  $a = k\sqrt{b}$   
 D)  $a = \frac{k}{\sqrt{b}}$

**Determine the constant of variation for the stated condition.**

3)  $b$  varies directly as  $a$ , and  $b = 78$  when  $a = 6$ .

- A)  $k = 13$   
 B)  $k = 14$   
 C)  $k = \frac{1}{13}$   
 D)  $k = 72$

4)  $y$  varies directly as  $x$ , and  $y = 5$  when  $x = 45$ .

- A)  $k = \frac{1}{9}$   
 B)  $k = 11$   
 C)  $k = 9$   
 D)  $k = 40$

5)  $y$  varies directly as  $x^2$ , and  $y = 50$  when  $x = 5$ .

A)  $k = 2$

B)  $k = 50$

C)  $k = \frac{1}{2}$

D)  $k = 45$

**If  $y$  varies directly as  $x$ , find the direct variation equation for the situation.**

6)  $y = 6$  when  $x = 24$

A)  $y = \frac{1}{4}x$

B)  $y = 4x$

C)  $y = x + 18$

D)  $y = \frac{1}{6}x$

7)  $y = 21$  when  $x = 12$

A)  $y = \frac{7}{4}x$

B)  $y = \frac{4}{7}x$

C)  $y = x + 9$

D)  $y = 3x$

8)  $y = 6$  when  $x = \frac{1}{5}$

A)  $y = 30x$

B)  $y = \frac{1}{30}x$

C)  $y = x + \frac{29}{5}$

D)  $y = \frac{1}{6}x$

9)  $y = 3.6$  when  $x = 0.9$

A)  $y = 4x$

B)  $y = 0.9x$

C)  $y = x + 2.7$

D)  $y = 0.25x$

10)  $y = 0.5$  when  $x = 2.5$

A)  $y = 0.2x$

B)  $y = 0.5x$

C)  $y = x - 2$

D)  $y = 5x$

**Solve the problem.**

11)  $y$  varies directly as  $z$  and  $y = 221$  when  $z = 13$ . Find  $y$  when  $z = 19$ .

A) 323

B) 361

C) 289

D) 169

12) If  $y$  varies directly as  $x$ , and  $y = 6$  when  $x = 7$ , find  $y$  when  $x = 35$ .

A) 30

B)  $\frac{6}{5}$

C)  $\frac{245}{6}$

D)  $\frac{5}{6}$

13) If  $y$  varies directly as  $x$ , and  $y = 700$  when  $x = 150$ , find  $y$  when  $x = 60$ .

A) 280

B) 1750

C)  $\frac{90}{7}$

D)  $\frac{7}{90}$

14)  $y$  varies directly as  $z^2$  and  $y = 294$  when  $z = 7$ . Find  $y$  when  $z = 9$ .

A) 486

B) 42

C) 378

D) 63

15) If  $y$  varies directly as the square of  $x$ , and  $y = 500$  when  $x = 15$ , find  $y$  when  $x = 12$ .

A) 320

B) 400

C)  $\frac{3125}{4}$

D) 625

16) If  $y$  varies directly as the cube of  $x$ , and  $y = 2$  when  $x = 8$ , find  $y$  when  $x = 40$ .

A) 250

B) 10

C)  $\frac{2}{5}$

D)  $\frac{2}{125}$

17) If  $y$  varies directly as the square root of  $x$ , and  $y = 4$  when  $x = 81$ , find  $y$  when  $x = 25$ .

A)  $\frac{20}{9}$

B)  $\frac{100}{81}$

C)  $\frac{36}{5}$

D)  $\frac{324}{25}$

The amount of water used to take a shower is directly proportional to the amount of time that the shower is in use. A shower lasting 22 minutes requires 4.4 gallons of water. Find the amount of water used in a shower lasting 4 minutes.

- A) 0.8 gallons                      B) 24.2 gallons                      C) 20 gallons                      D) 1.1 gallons

If the resistance in an electrical circuit is held constant, the amount of current flowing through the circuit is directly proportional to the amount of voltage applied to the circuit. When 9 volts are applied to a circuit, 225 milliamperes of current flow through the circuit. Find the new current if the voltage is increased to 13 volts.

- A) 325 milliamperes                      B) 117 milliamperes                      C) 312 milliamperes                      D) 350 milliamperes

The amount of gas that a helicopter uses is directly proportional to the number of hours spent flying. The helicopter flies for 3 hours and uses 39 gallons of fuel. Find the number of gallons of fuel that the helicopter uses to fly for 4 hours.

- A) 52 gallons                      B) 12 gallons                      C) 56 gallons                      D) 65 gallons

21) The distance that an object falls when it is dropped is directly proportional to the square of the amount of time since it was dropped. An object falls 128 feet in 2 seconds. Find the distance the object falls in 3 seconds.

- A) 288 feet                      B) 96 feet                      C) 192 feet                      D) 6 feet

For a resistor in a direct current circuit that does not vary its resistance, the power that a resistor must dissipate is directly proportional to the square of the voltage across the resistor. The resistor must dissipate  $\frac{1}{16}$  watt of power when the voltage across the resistor is 9 volts. Find the power that the resistor must

dissipate when the voltage across it is 18 volts.

- A)  $\frac{1}{4}$  watt                      B)  $\frac{1}{8}$  watt                      C)  $\frac{81}{16}$  watts                      D)  $\frac{9}{16}$  watt

## 2 Solve Inverse Variation Problems

**MULTIPLE CHOICE.** Choose the one alternative that best completes the statement or answers the question.

**Write an equation that expresses the relationship. Use k as the constant of variation.**

1) s varies inversely as z.

- A)  $s = \frac{k}{z}$                       B)  $s = \frac{z}{k}$                       C)  $s = kz$                       D)  $ks = z$

2) c varies inversely as the square of v.

- A)  $c = \frac{k}{v^2}$                       B)  $c = \frac{v^2}{k}$                       C)  $c = \frac{k}{\sqrt{v}}$                       D)  $c = \frac{\sqrt{k}}{v}$

**If y varies inversely as  $x^2$ , find the inverse variation equation for the situation.**

3)  $y = 5$  when  $x = 9$

- A)  $y = \frac{45}{x}$                       B)  $y = \frac{5}{9}x$                       C)  $y = \frac{x}{45}$                       D)  $y = \frac{1}{45x}$

4)  $y = 10$  when  $x = 7$

- A)  $y = \frac{70}{x}$                       B)  $y = \frac{10}{7}x$                       C)  $y = \frac{x}{70}$                       D)  $y = \frac{1}{70x}$



5)  $y = 20$  when  $x = \frac{1}{4}$

A)  $y = \frac{5}{x}$

B)  $y = 80x$

C)  $y = \frac{x}{5}$

D)  $y = \frac{1}{5x}$

6)  $y = \frac{1}{5}$  when  $x = 35$

A)  $y = \frac{7}{x}$

B)  $y = \frac{1}{175}x$

C)  $y = \frac{x}{7}$

D)  $y = \frac{1}{7x}$

7)  $y = 0.8$  when  $x = 0.2$

A)  $y = \frac{0.16}{x}$

B)  $y = 4x$

C)  $y = 6.25x$

D)  $y = \frac{6.25}{x}$

**Solve the problem.**

8)  $x$  varies inversely as  $v$ , and  $x = 15$  when  $v = 4$ . Find  $x$  when  $v = 12$ .

A)  $x = 5$

B)  $x = 16$

C)  $x = 20$

D)  $x = 3$

9)  $x$  varies inversely as  $y^2$ , and  $x = 2$  when  $y = 30$ . Find  $x$  when  $y = 5$ .

A)  $x = 72$

B)  $x = 24$

C)  $x = 50$

D)  $x = 6$

**Solve.**

When the temperature stays the same, the volume of a gas is inversely proportional to the pressure of the gas. If a balloon is filled with 72 cubic inches of a gas at a pressure of 14 pounds per square inch, find the new pressure of the gas if the volume is decreased to 24 cubic inches.

A) 42 pounds per square inch

B)  $\frac{12}{7}$  pounds per square inch

C) 28 pounds per square inch

D) 39 pounds per square inch

The amount of time it takes a swimmer to swim a race is inversely proportional to the average speed of the swimmer. A swimmer finishes a race in 60 seconds with an average speed of 5 feet per second. Find the average speed of the swimmer if it takes 75 seconds to finish the race.

A) 4 feet per second

B) 5 feet per second

C) 6 feet per second

D) 3 feet per second

If the force acting on an object stays the same, then the acceleration of the object is inversely proportional to its mass. If an object with a mass of 10 kilograms accelerates at a rate of 10 meters per second per second by a force, find the rate of acceleration of an object with a mass of 5 kilograms that is pulled by the same force.

20 meters per second per second

5 meters per second per second

10 meters per second per second

18 meters per second per second

If the voltage,  $V$ , in an electric circuit is held constant, the current,  $I$ , is inversely proportional to the resistance,  $R$ . If the current is 240 milliamperes when the resistance is 2 ohms, find the current when the resistance is 8 ohms.

A) 60 milliamperes

B) 960 milliamperes

C) 956 milliamperes

D) 120 milliamperes

While traveling at a constant speed in a car, the centrifugal acceleration passengers feel while the car is turning is inversely proportional to the radius of the turn. If the passengers feel an acceleration of 4 feet per second per second when the radius of the turn is 40 feet, find the acceleration the passengers feel when the radius of the turn is 80 feet.

- A) 2 feet per second per second  
 B) 3 feet per second per second  
 C) 4 feet per second per second  
 D) 5 feet per second per second

**Write an equation that expresses the relationship. Use k as the constant of variation.**

- 15) The intensity I of light varies inversely as the square of the distance D from the source. If the intensity of illumination on a screen 72 ft from a light is 3.2 foot-candles, find the intensity on a screen 90 ft from the light.  
 A) 2.048 foot-candles      B) 2.56 foot-candles      C) 4 foot-candles      D) 5 foot-candles
- 16) The weight of a body above the surface of the earth is inversely proportional to the square of its distance from the center of the earth. What is the effect on the weight when the distance is multiplied by 8?  
 A) The weight is divided by 64      B) The weight is divided by 8  
 C) The weight is multiplied by 64      D) The weight is multiplied by 8

### 3 Solve Combined Variation Problems

**MULTIPLE CHOICE. Choose the one alternative that best completes the statement or answers the question.**

**Write an equation that expresses the relationship. Use k for the constant of proportionality.**

1) w varies directly as x and inversely as y.

- A)  $w = \frac{xy}{k}$       B)  $w = \frac{xy}{k}$        $wxy = k$       D)  $w + x - y = k$

2) P varies directly as R and inversely as the square of S.

- A)  $P = \frac{kR}{S^2}$       B)  $P = \frac{kS^2}{R}$        $PRS^2 = k$       D)  $P + R - S^2 = k$

3) x varies directly as the square of y and inversely as the cube of z.

- A)  $x = \frac{ky^2}{z^3}$       B)  $xy^2z^3 = k$       C)  $x = \frac{kz^3}{y^2}$       D)  $x + y^2 - z^3 = k$

4) q varies directly as the square of r and inversely as s.

- A)  $q = \frac{kr^2}{s}$       B)  $q = \frac{ks}{r^2}$       C)  $q = k + r^2 - s^2$       D)  $q = kr^2s$

5) x varies jointly as y and z and inversely as the square root of a.

- A)  $x = \frac{kyz}{\sqrt{a}}$       B)  $x = \frac{ky}{z\sqrt{a}}$       C)  $x = \frac{k(y+z)}{\sqrt{a}}$       D)  $x = \frac{yz}{k\sqrt{a}}$

6) r varies directly as a and inversely as the difference between s and t.

- A)  $r = \frac{ka}{s-t}$       B)  $r = \frac{a}{k(s-t)}$       C)  $r = ka(s-t)$       D)  $r = \frac{k}{a(s-t)}$

Determine the constant of variation for the stated condition.

7)  $h$  varies directly as  $f$  and inversely as  $g$ , and  $h = 3$  when  $f = 39$  and  $g = 52$ .

A)  $k = 4$

B)  $k = \frac{1}{4}$

C)  $k = \frac{3}{4}$

D)  $k = 13$

8)  $c$  varies directly as  $a$  and inversely as  $b$ , and  $c = 2$  when  $a = 36$  and  $b = 8$ .

A)  $k = \frac{4}{9}$

B)  $k = \frac{9}{4}$

C)  $k = 8$

D)  $k = 4$

**Find the variation equation for the variation statement.**

9)  $t$  varies directly as  $r$  and inversely as  $s$ ;  $t = 5$  when  $r = 60$  and  $s = 60$

A)  $t = \frac{5r}{s}$

B)  $t = \frac{r}{5s}$

C)  $t = 5rs$

D)  $t = \frac{5}{rs}$

**Solve the problem.**

$y$  varies directly as  $x$  and inversely as the square of  $z$ .  $y = 110$  when  $x = 90$  and  $z = 3$ . Find  $y$  when  $x = 100$  and  $z = 10$ .

A) 11

B) 36.67

C) 1358.02

D) 110

$y$  varies jointly as  $a$  and  $b$  and inversely as the square root of  $c$ .  $y = 10$  when  $a = 4$ ,  $b = 5$ , and  $c = 64$ . Find  $y$  when  $a = 9$ ,  $b = 9$ , and  $c = 25$ .

A) 64.8

B) 16.2

C) 12.96

D) 1620

12) The volume  $V$  of a given mass of gas varies directly as the temperature  $T$  and inversely as the pressure  $P$ . A measuring device is calibrated to give  $V = 288 \text{ in}^3$  when  $T = 480^\circ$  and  $P = 20 \text{ lb/in}^2$ . What is the volume on this device when the temperature is  $140^\circ$  and the pressure is  $25 \text{ lb/in}^2$ ?

A)  $V = 67.2 \text{ in}^3$

B)  $V = 5.6 \text{ in}^3$

C)  $V = 87.2 \text{ in}^3$

D)  $V = 47.2 \text{ in}^3$

The time in hours it takes a satellite to complete an orbit around the earth varies directly as the radius of the orbit (from the center of the earth) and inversely as the orbital velocity. If a satellite completes an orbit 880 miles above the earth in 19 hours at a velocity of 39,000 mph, how long would it take a satellite to complete an orbit if it is at 1300 miles above the earth at a velocity of 39,000 mph? (Use 3960 miles as the radius of the earth.) Round your answer to the nearest hundredth of an hour.

A) 20.65 hours

B) 28.07 hours

C) 5.1 hours

D) 206.49 hours

14) The pressure of a gas varies jointly as the amount of the gas (measured in moles) and the temperature and inversely as the volume of the gas. If the pressure is 1056 kPa (kiloPascals) when the number of moles is 6, the temperature is  $320^\circ$  Kelvin, and the volume is 480 cc, find the pressure when the number of moles is 3, the temperature is  $330^\circ$  K, and the volume is 180 cc.

A) 1452

B) 1584

C) 726

D) 660

Body-mass index, or BMI, takes both weight and height into account when assessing whether an individual is underweight or overweight. BMI varies directly as one's weight, in pounds, and inversely as the square of one's height, in inches. In adults, normal values for the BMI are between 20 and 25. A person who weighs 178 pounds and is 67 inches tall has a BMI of 27.88. What is the BMI, to the nearest tenth, for a person who weighs 134 pounds and who is 65 inches tall?

A) 22.3

B) 22.7

C) 21.9

D) 21.6

#### 4 Solve Problems Involving Joint Variation

**MULTIPLE CHOICE. Choose the one alternative that best completes the statement or answers the question.**

**Write an equation that expresses the relationship. Use  $k$  as the constant of variation.**

1)  $a$  varies jointly as  $g$  and the square of  $z$ .

A)  $a = kgz^2$

B)  $a = \frac{kg}{z^2}$

C)  $a = kgkz^2$

D)  $a = \frac{kz^2}{g}$

2) a varies jointly as b and n.

A)  $a = kbn$

B)  $a = \frac{kb}{n}$

C)  $a = kbkn$

D)  $a = \frac{kn}{b}$

3) s varies jointly as t and the cube of u.

A)  $s = ktu^3$

B)  $stu^3 = k$

C)  $s = k + t + u^3$

D)  $s + t + u^3 = k$

4) x varies jointly as the square of y and the square of z.

A)  $x = ky^2z^2$

B)  $xy^2z^2 = k$

C)  $x = k + y^2 + z^2$

D)  $x + y^2 + z^2 = k$

5) a varies jointly as m and the sum of p and n.

A)  $a = km(p + n)$

B)  $a = \frac{km}{p + n}$

C)  $a = km + p + n$

D)  $a = k(mp + n)$

6) f varies jointly as b and the difference between p and h.

A)  $f = kb(p - h)$

B)  $f = \frac{kb}{p - h}$

C)  $f = kb + p - h$

D)  $f = k(bp - h)$

**Find the variation equation for the variation statement.**

7) z varies jointly as y and the cube of x;  $z = 120$  when  $x = 2$  and  $y = -3$

A)  $y = -5x^3y$

B)  $y = -5xy^3$

C)  $y = 5x^3y$

D)  $y = 5xy^3$

**Determine the constant of variation for the stated condition.**

8) t varies jointly as r and s, and  $t = 117$  when  $r = 26$  and  $s = 18$ .

A)  $k = \frac{1}{4}$

B)  $k = \frac{1}{18}$

C)  $k = 4$

D)  $k = 18$

9) t varies jointly as r and s, and  $t = 432$  when  $r = 12$  and  $s = 12$ .

A)  $k = 3$

B)  $k = \frac{1}{4}$

C)  $k = \frac{1}{3}$

D)  $k = 4$

10) t varies jointly as r and s, and  $t = 54$  when  $r = 27$ , and  $s = 18$ .

A)  $k = \frac{1}{9}$

B)  $k = \frac{1}{18}$

C)  $k = 9$

D)  $k = 18$

**Solve the problem.**

11) h varies jointly as f and g. Find h when  $f = 20$ ,  $g = 15$ , and  $k = 4$ .

A)  $h = 1200$

B)  $h = 300$

C)  $h = 75$

D)  $h = 3$

12) y varies jointly as x and z.  $y = 2.4$  when  $x = 30$  and  $z = 8$ . Find y when  $x = 40$  and  $z = 8$ .

A) 3.2

B) 320

C) 32

D) 6.4

13) f varies jointly as  $q^2$  and h, and  $f = 64$  when  $q = 4$  and  $h = 2$ . Find f when  $q = 3$  and  $h = 2$ .

A)  $f = 36$

B)  $f = 12$

C)  $f = 18$

D)  $f = 4$

14) f varies jointly as  $q^2$  and h, and  $f = -81$  when  $q = 3$  and  $h = 3$ . Find f when  $q = 2$  and  $h = 5$ .

A)  $f = -60$

B)  $f = -30$

C)  $f = -12$

D)  $f = -15$

15) f varies jointly as  $q^2$  and h, and  $f = 36$  when  $q = 3$  and  $h = 2$ . Find q when  $f = 192$  and  $h = 6$ .

A)  $q = 4$

B)  $q = 2$

C)  $q = 3$

D)  $q = 6$

- 16)  $f$  varies jointly as  $q^2$  and  $h$ , and  $f = 24$  when  $q = 2$  and  $h = 3$ . Find  $h$  when  $f = 192$  and  $q = 4$ .
- A)  $h = 6$                       B)  $h = 3$                       C)  $h = 2$                       D)  $h = 4$

The amount of paint needed to cover the walls of a room varies jointly as the perimeter of the room and the height of the wall. If a room with a perimeter of 75 feet and 10-foot walls requires 7.5 quarts of paint, find the amount of paint needed to cover the walls of a room with a perimeter of 45 feet and 10-foot walls.

- A) 4.5 quarts                      B) 450 quarts                      C) 45 quarts                      D) 9 quarts

The power that a resistor must dissipate is jointly proportional to the square of the current flowing through the resistor and the resistance of the resistor. If a resistor needs to dissipate 648 watts of power when 9 amperes of current is flowing through the resistor whose resistance is 8 ohms, find the power that a resistor needs to dissipate when 6 amperes of current are flowing through a resistor whose resistance is 7 ohms.

- A) 252 watts                      B) 42 watts                      C) 294 watts                      D) 378 watts

While traveling in a car, the centrifugal force a passenger experiences as the car drives in a circle varies jointly as the mass of the passenger and the square of the speed of the car. If a passenger experiences a force of 225 newtons when the car is moving at a speed of 50 kilometers per hour and the passenger has a mass of 100 kilograms, find the force a passenger experiences when the car is moving at 60 kilometers per hour and the passenger has a mass of 60 kilograms.

- A) 194.4 newtons                      B) 216 newtons                      C) 172.8 newtons                      D) 252 newtons

- 20) The amount of simple interest earned on an investment over a fixed amount of time is jointly proportional to the principle invested and the interest rate. A principle investment of \$4000.00 with an interest rate of 2% earned \$320.00 in simple interest. Find the amount of simple interest earned if the principle is \$3000.00 and the interest rate is 4%.

- A) \$480.00                      B) \$48,000.00                      C) \$240.00                      D) \$640.00

The voltage across a resistor is jointly proportional to the resistance of the resistor and the current flowing through the resistor. If the voltage across a resistor is 21 volts for a resistor whose resistance is 7 ohms and when the current flowing through the resistor is 3 amperes, find the voltage across a resistor whose resistance is 8 ohms and when the current flowing through the resistor is 6 amperes.

- A) 48 volts                      B) 42 volts                      C) 18 volts                      D) 24 volts

The pressure of a gas varies jointly as the amount of the gas (measured in moles) and the temperature and inversely as the volume of the gas. If the pressure is 1248 kPa (kiloPascals) when the number of moles is 8, the temperature is 320° Kelvin, and the volume is 640 cc, find the pressure when the number of moles is 9, the temperature is 290° K, and the volume is 1080 cc.

- A) 754                      B) 780                      C) 1508                      D) 1456



A  
A  
A  
A  
A  
A  
A  
A  
A  
A  
A  
A

**Solve Quadratic Equations with Complex Imaginary Solutions**

A  
A  
A  
A  
A  
A  
A  
A  
A  
A  
A  
A  
A  
A  
A  
A





A  
A

A  
A  
A  
A  
A  
A  
A  
A  
A  
A  
A  
A  
A  
A  
A  
A  
A  
A  
A  
A  
A



Solve Problems Involving a Quadratic Function's Minimum or Maximum Value

A  
A  
A  
A  
A  
A

A  
A  
A  
A  
A  
A  
A  
A  
A  
A  
A  
A  
A  
A

A  
A  
A  
A  
A  
A

## 2.3 Polynomial Functions and Their Graphs

### Identify Polynomial Functions

A  
A  
A  
A  
A  
A  
A  
A  
A  
A  
A  
A  
A  
A  
A  
A  
A  
A  
A

### Recognize Characteristics of Graphs of Polynomial Functions

A  
A  
A  
A  
A  
A  
A  
A  
A  
A  
A

A  
A  
A  
A  
A  
A  
A  
A  
A  
A  
A  
A  
A  
A

A  
A

A  
A  
A  
A  
A  
A  
A  
A  
A  
A  
A  
A  
A  
A  
A  
A



**Use Factoring to Find Zeros of Polynomial Functions**

- A
- A
- A
- A
- A

**Identify Zeros and Their Multiplicities**

- A
- A
- A
- A
- A
- A
- A
- A
- A
- A
- A
- A
- A
- A
- A





(a) falls to the left and rises to the right

x-intercepts:  $(0, 0)$ , touches x-axis and turns;  $(-3, 0)$ , crosses x-axis

y-intercept:  $(0, 0)$

(d)

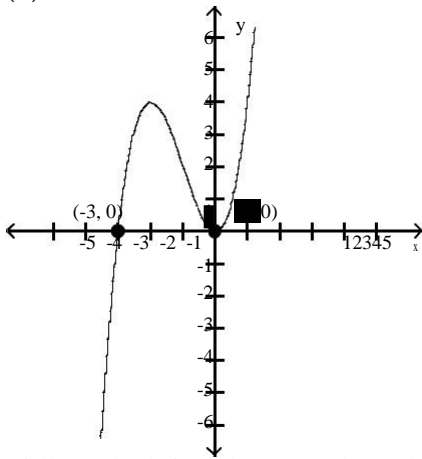

(a) falls to the left and rises to the right

x-intercepts:  $(3, 0)$ , touches x-axis and turns;  $(-2, 0)$ , crosses x-axis

y-intercept:  $(0, 18)$

(d)

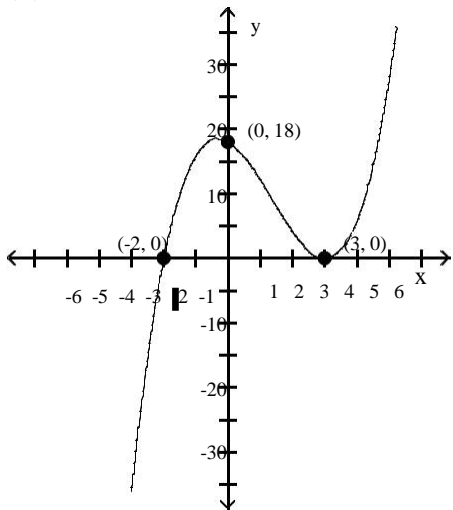



**Evaluate a Polynomial Using the Remainder Theorem**

- A
- A
- A
- A
- A

**Use the Factor Theorem to Solve a Polynomial Equation**

- A
- A
- A
- A
- A
- A
- A
- A
- A
- A

**2.5 Zeros of Polynomial Functions**

**Use the Rational Zero Theorem to Find Possible Rational Zeros**

- A
- A
- A
- A
- A
- A
- A
- A
- A
- A

**Find Zeros of a Polynomial Function**

- A
- A
- A
- A
- A
- A
- A
- A
- A
- A

**Solve Polynomial Equations**

- A
- A
- A
- A
- A
- A
- A
- A
- A
- A

A  
A  
A

**Use the Linear Factorization Theorem to Find Polynomials with Given Zeros**

A  
A  
A  
A  
A

**Use Descartes's Rule of Signs**

A  
A  
A  
A  
A  
A  
A  
A

**2.6 Rational Functions and Their Graphs**

**Find the Domains of Rational Functions**

A  
A  
A  
A  
A

**Use Arrow Notation**

A  
A  
A  
A  
A  
A  
A  
A  
A  
A

**Identify Vertical Asymptotes**

A  
A  
A  
D  
A  
A  
A

**Identify Horizontal Asymptotes**

A  
A  
D  
A  
A  
A  
A



A  
A







A  
A

A  
A  
A  
A  
A  
A  
A

**Solve Problems Involving Joint Variation**

A  
A  
A  
A  
A  
A  
A  
A  
A  
A  
A  
A  
A  
A  
A  
A  
A  
A  
A  
A  
A  
A