

Test Bank for Precalculus with Modeling and Visualization 6th Edition Rockswold 0134418034 9780134418032

Full link download

Test Bank:

<https://testbankpack.com/p/test-bank-for-prec calculus-with-modeling-and-visualization-6th-edition-rockswold-0134418034-9780134418032/>

MULTIPLE CHOICE. Choose the one alternative that best completes the statement or answers the question.

Select from the list of numbers all that belong to the specified set. 1)

Integers

$11, 7, -17, 0, 9$

A) 11, 0, 9

B) 11, -17, 0, 9

C) 11, 0

D) 11, -17, 0

Answer: B

2) Natural numbers

$2, 7, -9, 0, 25$

A) 2, 0

B) 2, 25

C) 2, 0, 25

D) 2, 0, 4

Answer: B

3) Real numbers

$7, 6, -9, 0, 25, \frac{-7}{0}$

A) 7, -9, 0, $\frac{-7}{0}$

B) 7, -9, 0, 25

C) 7, -9, 0, 25

D) 7, 6, -9, 0, 25

Answer: D

4) Rational numbers

$8, 5, -16, 0, 4, \frac{-5}{0}, 0.1$

A) 8, -16, 0, 4, 0.1

B) 5, 4

C) 5, $\frac{0}{7}, 0.1$

D) 8, 0, 4

Answer: A

5) Irrational numbers

$1, 5, -7, 0, 25, \frac{-4}{0}, 0.18$

A) $\sqrt{5}, 25, 0.18$

B) 5, 25

C) $5, \frac{-4}{0}$

D) 5

Answer: D

6) Rational numbers

-4, 0.6×10^6 , 78, 8.3, 2, 0.66

A) -4, 0.6×10^6 , 78, 8.3, 2

~~A)~~ 78, 2, 0.66

B) 78

D) -4, 0.6×10^6 , 8.3, 0.66, 2

Answer: D

$\sqrt{-}$ $\sqrt{-}$

-

$\sqrt{-}$

- $\sqrt{-}$

$\sqrt{-}$

$\sqrt{-}$

$\sqrt{-}$ $\sqrt{-}$

-

$\sqrt{-}$

$\sqrt{-}$ $\sqrt{-}$

$\sqrt{-}$

$\sqrt{-}$

$\sqrt{-}$ $\sqrt{-}$

$\sqrt{-}$ $\sqrt{-}$

$\sqrt{-}$ $\sqrt{-}$

$\sqrt{-}$

$\sqrt{-}$

$\sqrt{-}$ $\sqrt{-}$ $\sqrt{-}$ $\sqrt{-}$

$\sqrt{-}$

-

7) Irrational numbers

$-4, 9.1 \times 10^3, 76, \sqrt[8]{6}, 4.5, 0.49$ A) $\sqrt{76}$
C) $\sqrt[76]{0.49}$

B) $\sqrt[76]{4.5}, 0.49$
D) $-4, 9.1 \times 10^3, 0.49, 4.5$

Answer: A

For the measured quantity, state the set of numbers that is most appropriate to describe it. Choose from the natural numbers, integers, or rational numbers.

8) Populations of cities

A) Rational numbers

B) Natural numbers

C) Integers

Answer: B

9) Hat sizes

A) Natural numbers

B) Integers

C) Rational numbers

Answer: C

10) Temperatures given in a winter weather forecast in Alaska A)

Rational numbers

B) Natural numbers

C) Integers

Answer: C

11) Temperatures given in a weather forecast in Cayembe, Equador (this town is on the equator) A)

Rational numbers

B) Integers

C) Natural numbers

Answer: C

12) Numbers of sales of cakes at a bakery

A) Integers

B) Natural numbers

C) Rational numbers

Answer: B

13) The lengths of randomly cut pieces of string (measured using a ruler) A)

Natural numbers

B) Rational numbers

C) Integers

Answer: B

14) The populations of armies of termites living in the walls of houses A)

Natural numbers

B) Integers

C) Rational numbers

Answer: A

15) The lengths of randomly cut pieces of string measured to the nearest inch A)

Integers

B) Rational numbers

C) Natural numbers

Answer: C

16) The average speeds of race cars for one lap at Wilmot Speedway A)

Integers

B) Natural numbers

C) Rational numbers

Answer: C

17) The number of cars sold in an average month at Bob's Auto Sales A)

Integers

B) Rational numbers

C) Natural numbers

Answer: C

Write the number in scientific notation.

18) 7,100,000

A) 7.1×10^7

B) 7.1×10^{-7}

C) 7.1×10^6

D) 7.1×10^{-6}

Answer: C

19) 0.000286

A) 2.86×10^{-3}

B) 2.86×10^4

C) 2.86×10^{-5}

D) 2.86×10^{-4}

Answer: D

20) 790,000

A) 7.9×10^6

B) 7.9×10^{-5}

C) 7.9×10^5

D) 7.9×10^{-6}

Answer: C

21) 9400

A) 9.4×10^{-3}

B) 9.4×10^3

C) 9.4×10^{-2}

D) 9.4×10^2

Answer: B

22) 0.0000005

A) 5×10^{-8}

B) 5×10^{-6}

C) 5×10^{-7}

D) 5×10^{-9}

Answer: C

Write the number in standard form.

23) 1.29×10^6

A) 12,900,000

B) 77.4

C) 1,290,000

D) 129,000

Answer: C

24) 4.002×10^7

A) 40,020,000

B) 4,002,000

C) 400,200,000

D) 280.14

Answer: A

25) 7.4889×10^5

A) 7,488,900

B) 748,890

C) 374.445

D) 74,889

Answer: B

26) 7.21×10^{-4}

A) 0.00721

B) 0.000721

C) -721,000

D) 0.0000721

Answer: B

27) 3.392×10^{-5}

A) 0.000003392

B) -339,200

C) 0.0003392

D) 0.00003392

Answer: D

28) 5.247×10^{-6}

A) 0.000005247

B) 0.0000005247

C) 0.00005247

D) -5,247,000

Answer: A

- 29) 2.0365×10^{-7}
 A) -203,650,000 B) 0.00000020365 C) 0.00000020365 D) 0.0000020365
 Answer: C

Use a calculator to approximate the expression. Write your answer in scientific notation, and round to the nearest tenth as needed.

- 30) $(2.8 \times 10^5)(2.9 \times 10^7)$ A) 81×10^{35} B) 8.1×10^{35} C) 81×10^{12} D) 8.1×10^{12}
 Answer: D

- 31) $\frac{6.9 \times 10^6}{0.0096}$
 A) 6.8×10^6 B) 7.2×10^8 C) 7.6×10^8 D) 7.2×10^6
 Answer: B

- 32) $(2.5 \times 10^5) + (1.3 \times 10^7)$ A) 1.5×10^{12} B) 1.3×10^7 C) 1.5×10^{-7} D) 1.3×10^{-12}
 Answer: B

Use a calculator to evaluate the expression. Round your answer to the nearest thousandth.

- 33) $\sqrt[3]{107}$
 A) 5.447 B) 7.047 C) 3.747 D) 4.747
 Answer: D

- 34) $\sqrt[4]{p^3}$
 A) 9.762 B) 8.775 C) 6.304 D) 9.799
 Answer: B

- 35) $|2 - p^2|$
 A) 9.882 B) -7.87 C) -9.881 D) 7.87
 Answer: D

- 36) $\frac{4.19 - 5.86}{11.6 + 3.7}$
 A) -0.063 B) -0.071 C) -0.058 D) -0.109
 Answer: D

- 37) $4.3(4.2^2) - 2(4) + 6$
 A) 73.852 B) 79.852 C) 67.852 D) 0.852
 Answer: A

Find the percent change if a quantity changes from P_1 to P_2 . Round your answer to the nearest tenth if appropriate.

- 38) $P_1 = \$18, P_2 = \55
 A) -205.6 B) 67.3 C) 205.6 D) -67.3
 Answer: C

39) $P_1 = 5.3, P_2 = 2.3$

- A) 56.6 B) -56.6 C) 130.4 D) -130.4

Answer: B

Use the information given in the table to solve the problem.

40) The table gives the Consumer Price Index for selected years.

Year	1960	1965	1970	1975	1980	
CPI	29.9	38.4	63.65	84.1		

What is the percent change (to the nearest tenth of a percent) in prices from 1965 to 1980?

- A) 221.7 % B) 120.1 % C) 121.3 % D) 123.6 %

Answer: C

41) The table gives the Consumer Price Index for selected years.

Year	1960	1965	1970	1975	1980	
CPI	29.8	35.5	46.8	63.4	81.8	

What is the percent change (to the nearest tenth of a percent) in prices from 1960 to 1975? A)

- 112.8 % B) 117 % C) 114 % D) 122.8 %

Answer: A

42) The table gives the Consumer Price Index for selected years.

Year	1960	1962	1964	1966	1968	
CPI	30.1	37.9	48.6	69.1	78.5	

Use the concept of an average or mean to estimate the CPI in 1961. A)

- 34.9 B) 34 C) 35.5 D) 31.6

Answer: B

43) The table gives the Consumer Price Index for selected years.

Year	1960	1962	1964	1966	1968	
CPI	29.6	39.3	46.3	57.3	79.9	

Use the concept of an average or mean to estimate the CPI in 1965.

- A) 54.9 B) 51.8 C) 50.2 D) 52.5

Answer: B

44) The table gives the value of a 1957 Chevy BelAire in #2 condition for selected years.

Year		1980	1982	1984	1986	1988	
Value in dollars		8351	8489	9935	10,610	12,935	

What is the percent change (to the nearest tenth of a percent) in the value of a 1957 Chevy BelAir in #2 condition from 1982 to 1986.

- A) 25 % B) 25.9 % C) 21.3 % D) 30.3 %

Answer: A

45) The table gives the value of a 1957 Chevy BelAire in #2 condition for selected years.

Year		1980	1982	1984	1986	1988	
Value in dollars		8322	8488	9913	10,554	12,402	

Use the concept of an average or mean to estimate the value of a 1957 Chevy BelAire in #2 condition in 1983.

- A) \$ 9171.37 B) \$ 9200.50 C) \$ 9229.63 D) \$ 9190.50

Answer: B

- 46) The table gives the value of a 1957 Chevy BelAire in #2 condition for selected years.

Year	1980	1982	1984	1986	1988
Value in dollars	8,230	8,460	9,875	10,603	12,924

What is the percent change (to the nearest tenth of a percent) in the value of a 1957 Chevy BelAir in #2 condition from 1982 to 1988?

- A) 52.8 % B) 50.7 % C) 57.1 % D) 51.2 %

Answer: A

- 47) The table gives the value of a 1957 Chevy BelAire in #2 condition for selected years.

Year	1980	1982	1984	1986	1988
Value in dollars	8,365	8,458	9,857	10,539	11,939

Use the concept of an average or mean to estimate the value of a 1957 Chevy BelAire in #2 condition in 1985.

- A) \$ 10,174.28 B) \$ 10,209.07 C) \$ 10,202.23 D) \$ 10,198.00

Answer: D

Solve. Write results using scientific notation.

- 48) Assume that the volume of the earth is 4.0×10^{14} cubic meters and the volume of a bacterium is 3.4×10^{-16} cubic meters.

If the earth could be filled with bacteria, how many would it contain? A)

- 1.18 $\times 10^{-31}$ bacteria B) 1.18×10^{30} bacteria
C) 1.18×10^{31} bacteria D) 1.18×10^{-30} bacteria

Answer: B

- 49) A computer can do one calculation in 1.9×10^{-7} seconds. How long would it take the computer to do a trillion (10^{12}) calculations? A)

- 1.9×10^{-7} sec B) 1.9×10^5 sec C) 1.9×10^6 sec D) 1.9×10^{12} sec

Answer: B

- 50) The national debt of a small country is \$6,960,000,000 and the population is 2,665,000. What is the amount of debt per person?

- A) $\$2.61 \times 10^6$ B) $\$26.10 \times 10^2$ C) \$2.61 D) $\$2.61 \times 10^3$

Answer: D

- 51) A company produced 922,000 small appliances in one year and made a profit of \$7,600,000. What was the profit on each appliance?

- A) $\$1.21 \times 10^1$ B) $\$1.21 \times 10^{-1}$ C) \$8.24 D) $\$8.24 \times 10^{-1}$

Answer: C

- 52) The earth is approximately 92,900,000 miles from the sun. If 1 mile = 1.61×10^3 m, what is the distance to the sun in meters?

- A) 1.50×10^{10} m B) 1.50×10^{11} m C) 5.7×10^{-10} m D) 5.7×10^{10} m

Answer: B

- 53) The distance from the earth to the sun is 92,900,000 miles. How long would it take a rocket, traveling at 2.9×10^3 miles per hour, to reach the sun?

- A) 3.2×10^2 hr B) 3.2×10^3 hr C) 3.2×10^4 hr D) 3.2 hr

Answer: C

- 54) A light-year is the distance that light travels in one year. Find the number of miles in a light-year if light travels 1.86×10^5 miles per second. A) 5.9×10^{14} miles B) 5.9×10^7 miles C) 5.9×10^5 miles D) 5.9×10^{12} miles

Answer: D

- 55) The following equation gives the number of atoms in 390 g of fluorine. How many atoms are there?

$$A = 390 \text{ g Fl} \times \frac{1 \text{ mole Fl}}{19.0 \text{ g Fl}} \times \frac{6.022 \times 10^{23} \text{ atoms}}{1 \text{ mole Fl}}$$

- A) 1.23×10^{25} atoms B) 1.24×10^{25} atoms C) 2.93×10^{24} atoms D) 4.46×10^{26} atoms

Answer: B

Solve the problem.

- 56) A comet has a nearly circular orbit around a star with a radius of 330 million miles and requires 8.24 earth years to complete one orbit. Estimate the orbital speed of the comet in miles per hour. Round to the nearest mile per hour.

- A) 28,725 mph B) 252 mph C) 689,404 mph D) 251,632,423 mph

Answer: A

- 57) An oil spill of 3971 cubic centimeters is spilled onto a pond and spreads out in a circular shape having a diameter of 766 centimeters. Approximate the thickness of the oil film to four decimal places.

- A) 1.6501 cm B) 0.0086 cm C) 3.3003 cm D) 116.0506 cm

Answer: B

Plot each number on a number line.

- 58) -1.5, 0, 5, -3

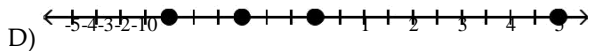
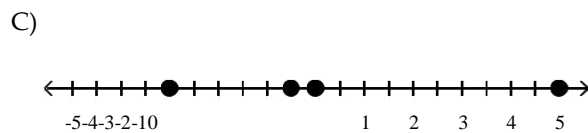
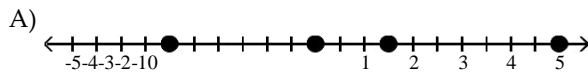
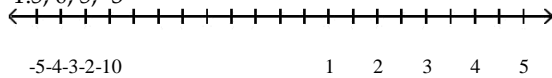

Answer: D

59) 0.8, -0.6, -2, 0

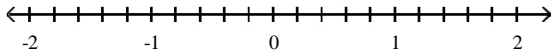

A)



C)



B)



D)



Answer: B

60) 250, -50, 300, -200

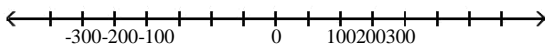

A)

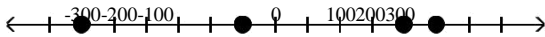

C)



B)

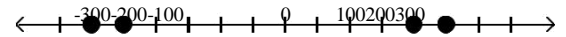

D)

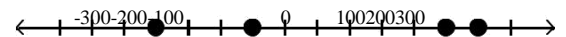

Answer: D

61) -30, 10, 40, -60

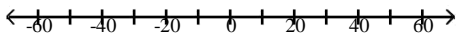

A)

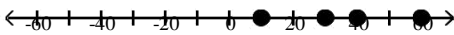

C)

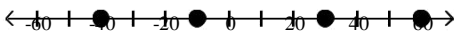

B)

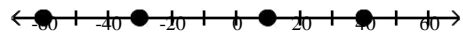

D)

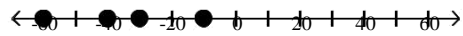

Answer: B

Find the mean of the set of data. Round to the nearest tenth. 62)

13, 9, 1, 1, 7, 10, 13, 5, 12

A) 7.8

B) 10.8

C) 7.9

D) 8.0

Answer: C

63) 110, 49, 2, 67, 70, 43, 54, 111, 4

A) 48.9

B) 56.2

C) 63.8

D) 56.7

Answer: D

64) 3, 11, 4, 3, 3, 4, 4, 4, 4, 11, 4, 11, 4
A) 4.9 B) 5.4 C) 5.3 D) 6.4
Answer: B

65) 80, 42, 53, 53, 42, 80, 2, 2, 2, 80, 2, 2, 53
A) 38.1 B) 37.9 C) 36.7 D) 40.9
Answer: B

66) 229, 221, 213, 213, 213, 213, 221, 215, 215, 215, 221, 221 A)
217.5 B) 217.7 C) 217.2 D) 218.4
Answer: A

67) 0, 3, 5, 7, 7, 3, 5, 0, 0, 7, 3, 3
A) 3.6 B) 3.8 C) 4.8 D) 4.6
Answer: A

Find the median of the set of data.

68) 6, 10, 17, 23, 32, 43, 50
A) 26 B) 32 C) 17 D) 23
Answer: D

69) 15, 30, 40, 48, 60, 75, 80
A) 40 B) 60 C) 50 D) 48
Answer: D

70) 92, 25, 218, 112, 276, 240, 233
A) 171 B) 218 C) 112 D) 233
Answer: B

71) 69, 141, 246, 275, 425, 482
A) 275 B) 234.5 C) 260.5 D) 246
Answer: C

72) 8, 5, 27, 17, 29, 50, 37, 32
A) 27 B) 29 C) 25.5 D) 28
Answer: D

73) 39, 20, 8, 5, 26, 13, 29, 30, 39, 30
A) 27.5 B) 29 C) 24 D) 26
Answer: A

Find the distance in the xy-plane between the two points. Round an approximate result to the nearest hundredth. 74)

(12, 0) and (0, 9)
A) 3 B) 3.87 C) 30 D) 15
Answer: D

75) (5, 7) and (15, 31)
A) 24 B) 4.90 C) 26 D) 10
Answer: C

76) (-5, 1) and (-9, -2)

A) -5

B) 5

C) 2.24

D) 12

Answer: B

77) (-1, 1) and (3, -5)

A) 6.93

B) 24

C) 7.21

D) 26

Answer: C

78) (-2, -2) and (0, -8)

A) 3.16

B) 20

C) 6

D) 6.32

Answer: D

79) (7.3, 1.5) and (1.3, 7.5)

A) 16.97

B) 12

C) 8.49

D) 1.41

Answer: C

80) (4.6, -0.5) and (2.6, -4.5)

A) 4

B) 4.47

C) 8.94

D) 2.24

Answer: B

Find the midpoint of the line segment joining the two points. 81)

(7, 0) and (9, 2)

A) (6, 2)

B) (1, -1)

C) (2, -2)

D) (1, 1)

Answer: D

82) (2, -6) and (-4, 0)

A) (1, -3)

B) (3, -3)

C) (2, -6)

D) (6, -6)

Answer: A

83) (-2, -6) and (3, 9)

A) (-5, -15)
()

B) (-5, -15)
(- 2)

C) (1, 3)
(2, 2)

D) (1, 3)
()

Answer: C

84) (-2, -3) and (4, -8)

A) (6, 5)

B) (1, 11)
(2)

C) (2, -11)

D) (3, 5)
(- 2)

Answer: B

85) $\left(\frac{3}{2}, \frac{5}{2} \right)$ and $\left(\frac{5}{2}, -\frac{9}{2} \right)$

A) (0, 36)

B) (2, 3)

C) (100, 144)

D) (0, 3)
(2)

Answer: D

86) $(5\sqrt{10}, -10\sqrt{10})$ and $(-5, 0)$

A) $\left(10\sqrt{10}, -\frac{\sqrt{30}}{2} \right)$

B) (-5, 10)

C) $\left(5\sqrt{10}, \frac{\sqrt{10}}{2} \right)$

D) $\left(5\sqrt{10}, \frac{\sqrt{10}}{2} \right)$

Answer: D

87) $(-6\sqrt{1})$ and $(0, 3)$ $\sqrt{}$
 A) $(-6\sqrt{1+3})$ $\sqrt{}$

B) $\left(\frac{6\sqrt{1-3}}{2}, \frac{\sqrt{}}{2} \right)$

C) $\left(\frac{-6\sqrt{3}\sqrt{}}{2}, 12 \right)$

D) $\left(\frac{-6\sqrt{}}{2}, \frac{1+3\sqrt{}}{2} \right)$

Answer: D

Find the domain and range of the relation.

88) $\{(-6,9), (3,-5), (5,-3), (1,-2), (7,-8)\}$

A) $D = \{-8, -6, 9, 3, -5\}$; $R = \{5, -3, 1, -2, 7\}$

C) $D = \{5, -3, 1, -2, 7\}$; $R = \{-8, -6, 9, 3, -5\}$

B) $D = \{5, 1, 7, -6, 3\}$; $R = \{-3, -2, -8, 9, -5\}$

D) $D = \{-3, -2, -8, 9, -5\}$; $R = \{5, 1, 7, -6, 3\}$

Answer: B

89) $\{(8,4), (-8,5), (2,2), (2,-5)\}$

A) $D = \{4, 2, 5, -5\}$; $R = \{8, 2, -8\}$

C) $D = \{8, 2, -8, -2\}$; $R = \{4, 2, 5, -5\}$

B) $D = \{8, 2, -8, 2\}$; $R = \{4, 2, 5, -5\}$

D) $D = \{8, 2, -8\}$; $R = \{4, 2, 5, -5\}$

Answer: D

90) $\{(10,-4), (10,-9), (-9,-7), (-2,-3), (11,6)\}$

A) $D = \{-2, 11, 10, -9\}$; $R = \{-3, 6, -9, -7, -4\}$

C) $D = \{-3, 6, -9, -7, -4\}$; $R = \{-2, -2, 11, 10, -9\}$

B) $D = \{-2, -4, 11, 10, -9\}$; $R = \{-3, 6, -9, -7, -4\}$

D) $D = \{-2, -2, 11, 10, -9\}$; $R = \{-3, 6, -9, -7, -4\}$

Answer: A

91) $\{(-4,-8), (-2,2), (-8,9), (-8,5)\}$

A) $D = \{-2, -4, -8, -8\}$; $R = \{2, -8, 9, 5\}$

C) $D = \{2, -8, 9, 5\}$; $R = \{-2, -4, -8\}$

B) $D = \{-2, -4, -8, 8\}$; $R = \{2, -8, 9, 5\}$

D) $D = \{-2, -4, -8\}$; $R = \{2, -8, 9, 5\}$

Answer: D

92) $\{(-7,-4), (-2,5), (-8,-1), (8,-3)\}$

A) $D = \{-8, -7, -2, 8\}$; $R = \{-1, -4, 5, -3\}$

C) $D = \{-8, -7, -2, 8\}$; $R = \{-1, 4, -4, 5, -3\}$

B) $D = \{-8, -7, -2, 8\}$; $R = \{-1, -1, -4, 5, -3\}$

D) $D = \{-1, -4, 5, -3\}$; $R = \{-8, -7, -2, 8\}$

Answer: A

93) $\{(-67,-94), (-43,-68), (-15,-50), (25, -27), (85,44)\}$

A) $D = \{-94, -68, -50, -27\}$; $R = \{-67, -43, -15, 25\}$

B) $D = \{-67, -43, -15, 25, 85\}$; $R = \{-94, -68, -50, -27, 44\}$ C)

$D = \{-94, -68, -50, -27, 44\}$; $R = \{-67, -43, -15, 25, 85\}$

D) $D = \{-67, -43, -15, 25\}$; $R = \{-94, -68, -50, -27\}$

Answer: B

94) $\{(-11.54, -8.99), (-8.07, -6.13), (-3.52, -3.07), (5.97, -0.1), (12.13, 4.56)\}$

A) $D = \{-11.54, -8.07, -3.52, 5.97, 12.13\}$; $R = \{-8.99, -6.13, -3.07, -0.1, 4.56\}$

B) $D = \{-8.99, -6.13, -0.1, 4.56\}$; $R = \{-11.54, -8.07, -3.52, 5.97\}$ C)

$D = \{-11.54, -8.07, 5.97, 12.13\}$; $R = \{-8.99, -6.13, -3.07, -0.1\}$

D) $D = \{-8.99, -6.13, -3.07, -0.1, 4.56\}$; $R = \{-11.54, -8.07, -3.52, 5.97, 12.13\}$

Answer: A

Plot the relation in the xy-plane.

95) $\{(0, 3), (-3, -2), (4, 1), (-8, -10), (-1, 9)\}$

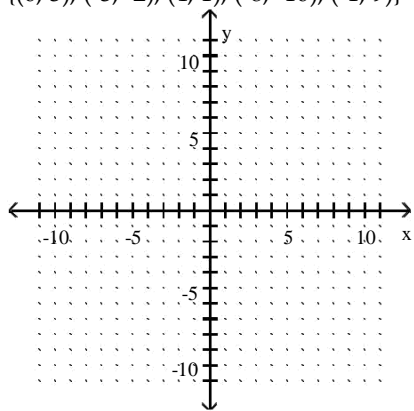

A)

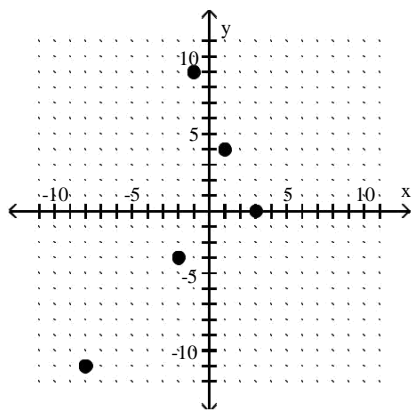

B)

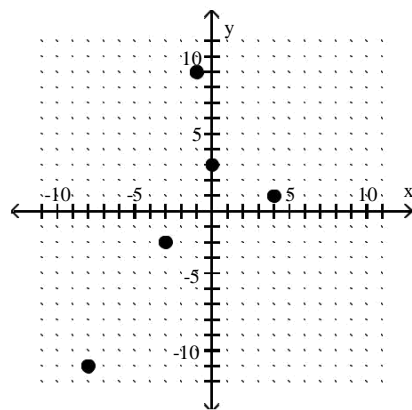

C)

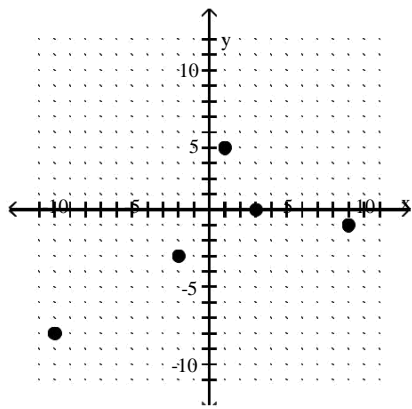

D)

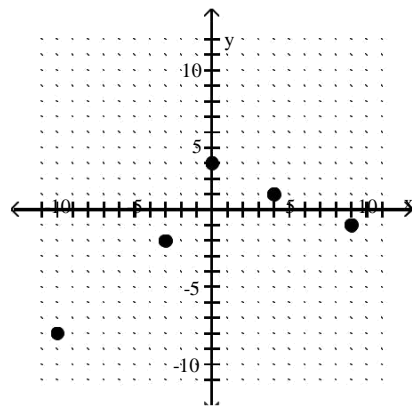

Answer: B

96) $\{(10, 35), (-35, -20), (40, 15), (-57, -20), (-10, 64)\}$

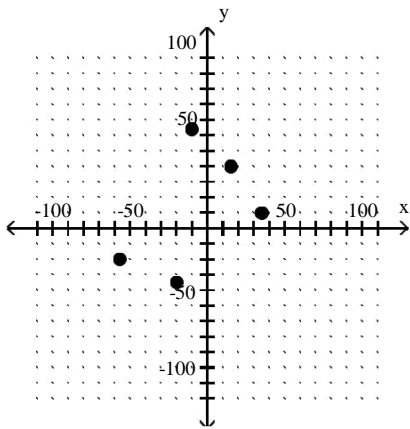
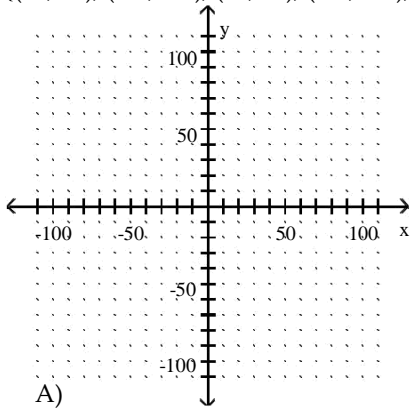

B)

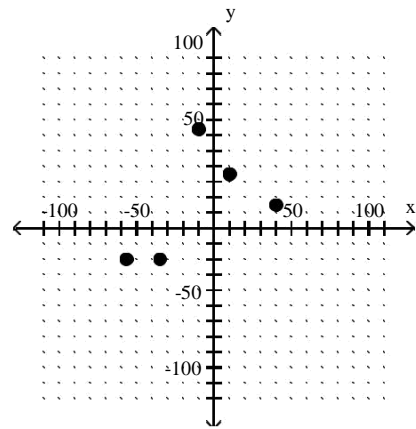

C)

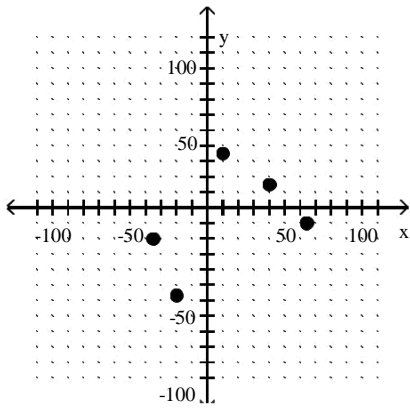

D)

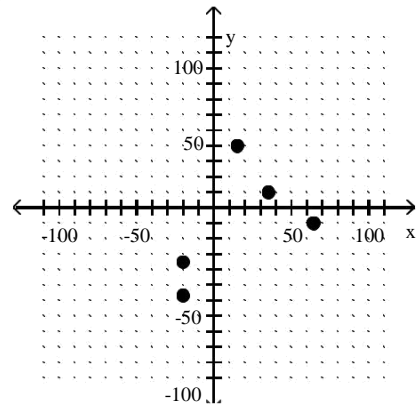

Answer: B

97) $\{(0.4, 1.3), (-1.3, -1.2), (1.4, -0.1), (0.7, -0.5), (-1, 0.9)\}$

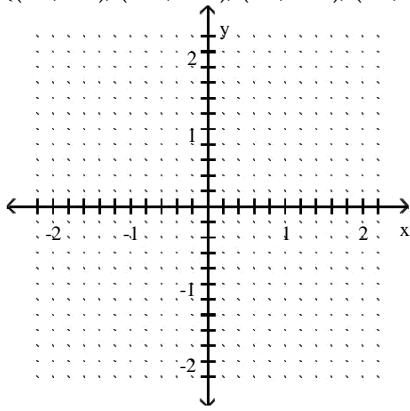

A)

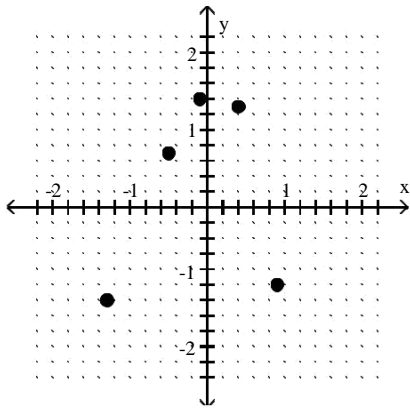

B)

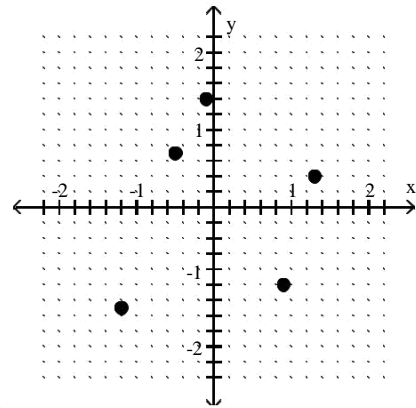

C)

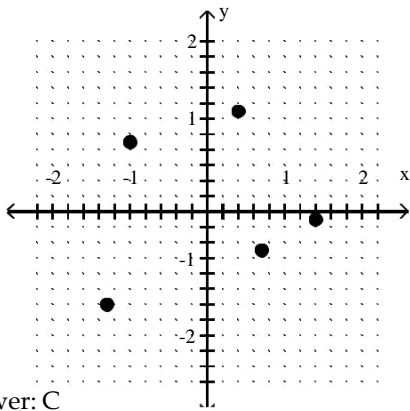

D)

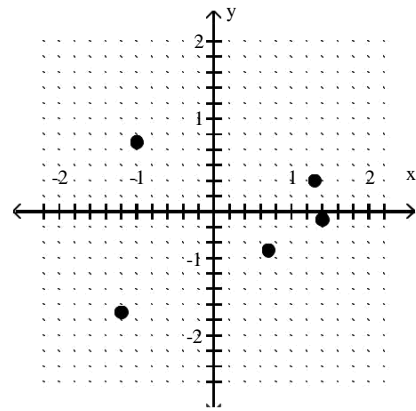

Answer: C

98) $\{(0, 3), (-3, 2), (4, 1), (-4, -10), (-1, 7)\}$

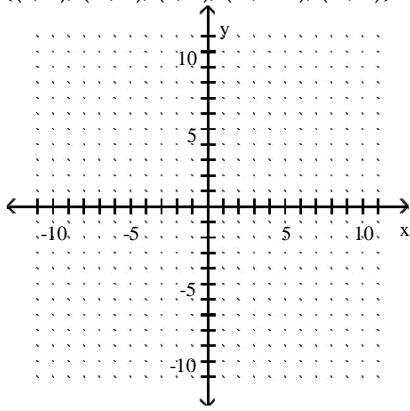

A)

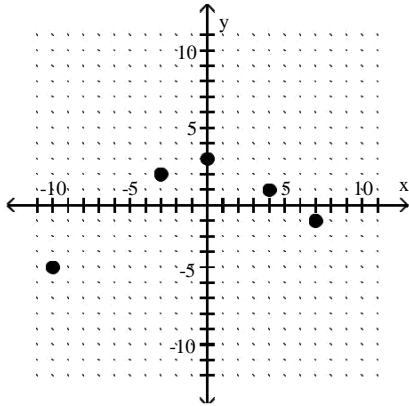

B)

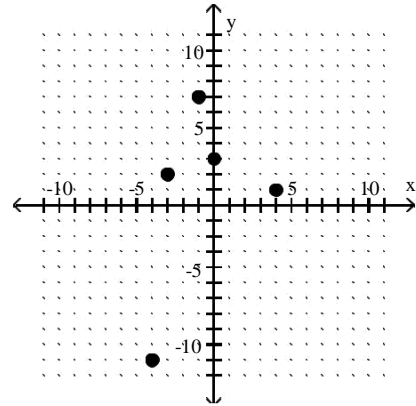

C)

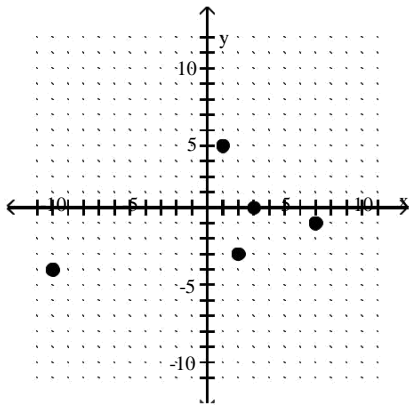

D)

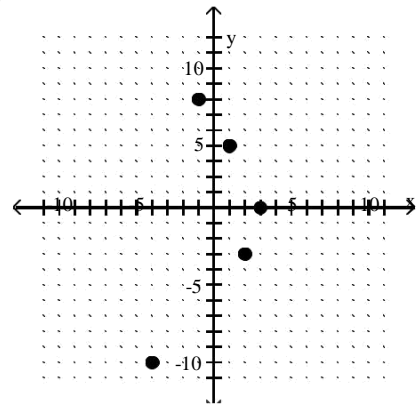

Answer: B

99) $\{(10, 35), (2, -29), (40, 15), (-78, -20), (-10, 63)\}$

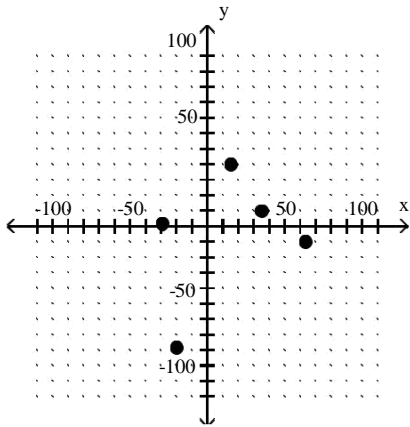
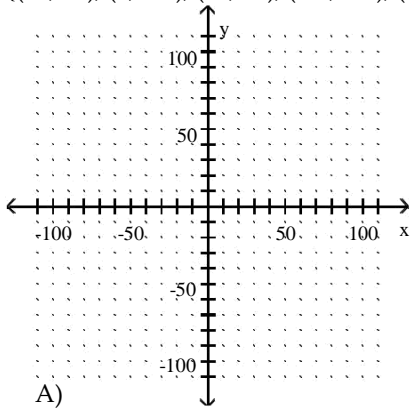

B)

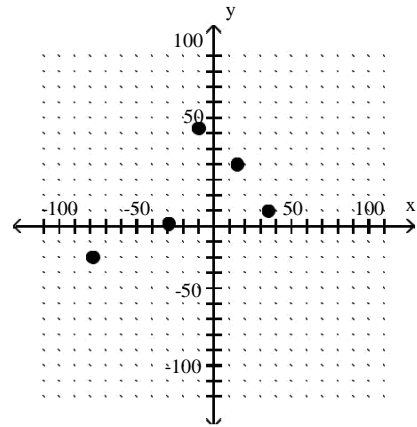

C)

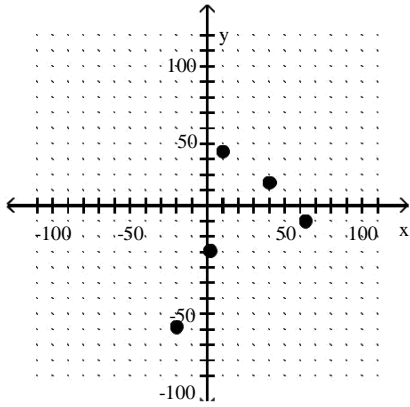

D)

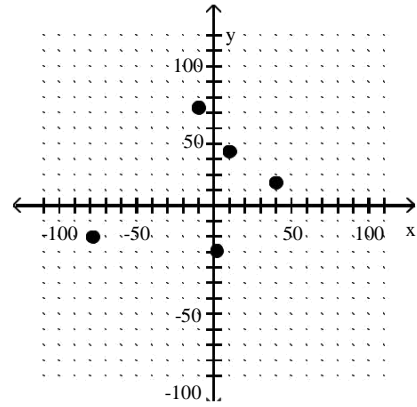

Answer: D

100) $\{(0.4, 1.3), (-1.3, 1), (1.4, -0.1), (0.5, -0.5), (-1, 0.6)\}$

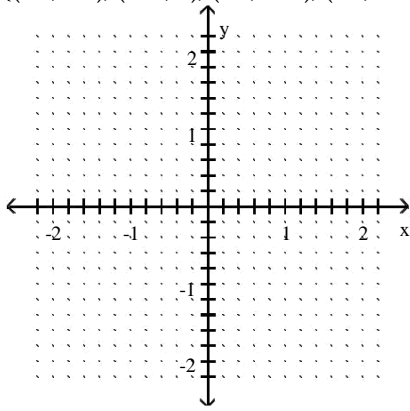

A)

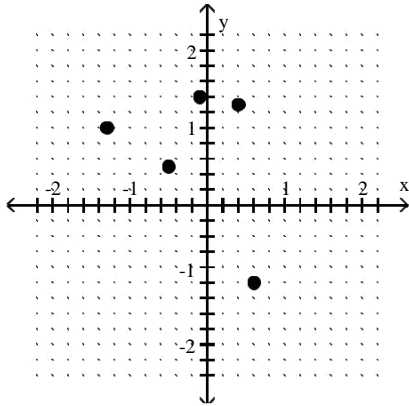

B)

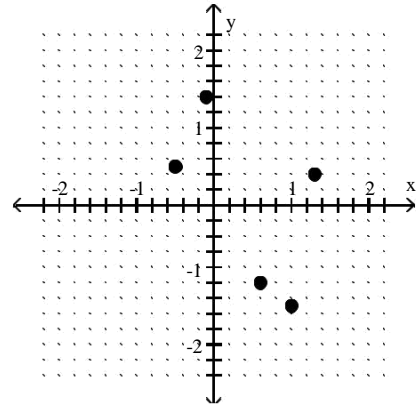

C)

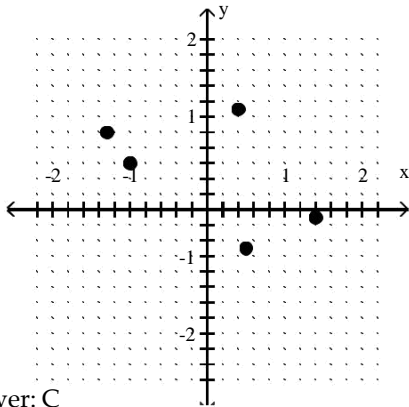

D)

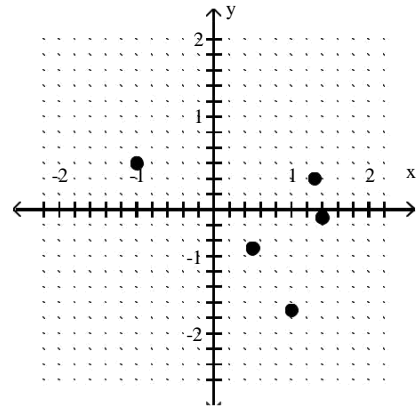

Answer: C

101) $\{(0, -6), (-5, -4), (-7, 0), (-7, -10), (-1, 7)\}$

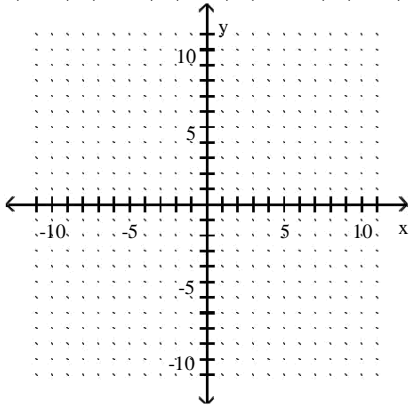

A)

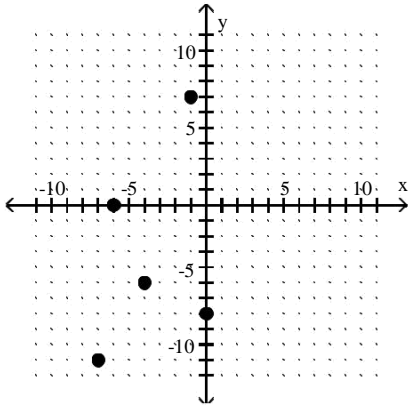

B)

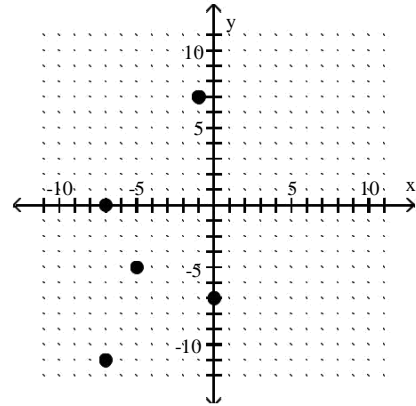

C)

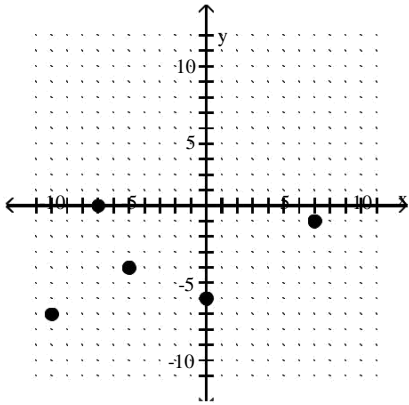

D)

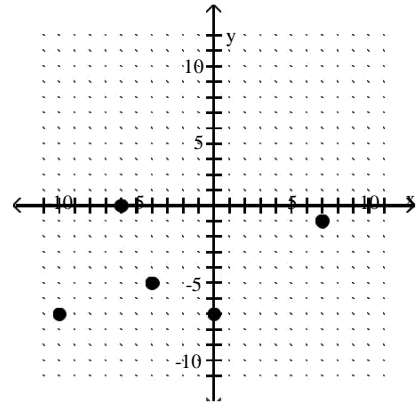

Answer: B

102) $\{(0, 56), (-7, -23), (-23, 0), (-77, -20), (-10, 50)\}$

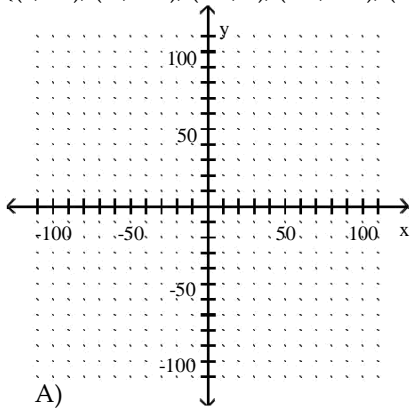

B)

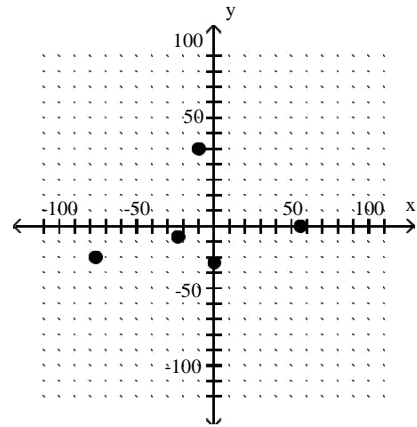

C)

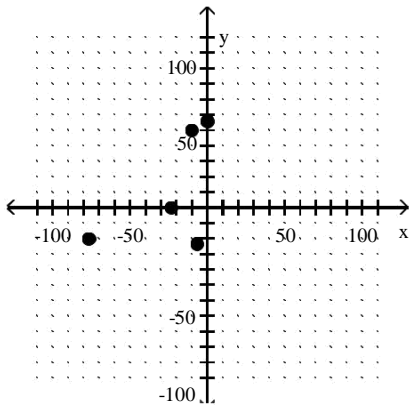

D)

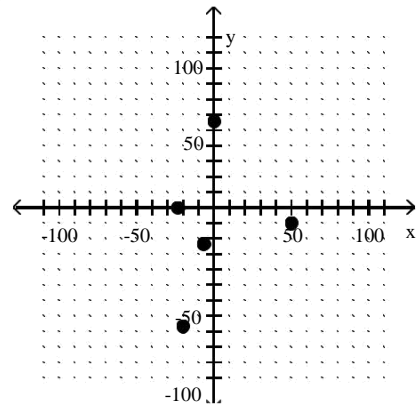

Answer: C

103) $\{(0, -1.4), (-1.1, 1.5), (-0.8, 0), (0.8, -0.5), (-1, 0.6)\}$

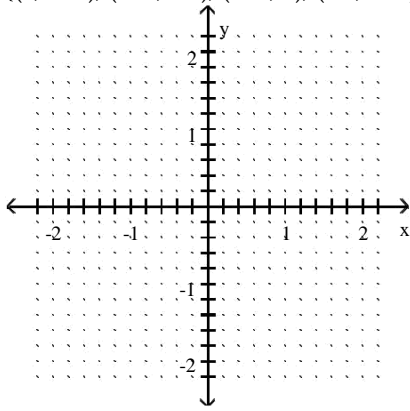

A)

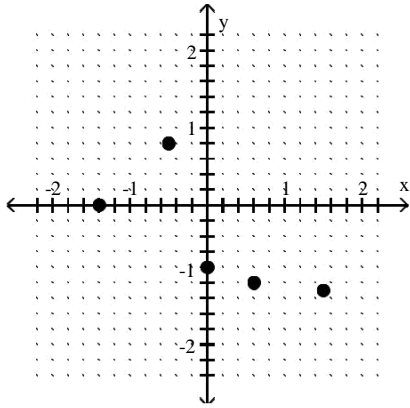

C)

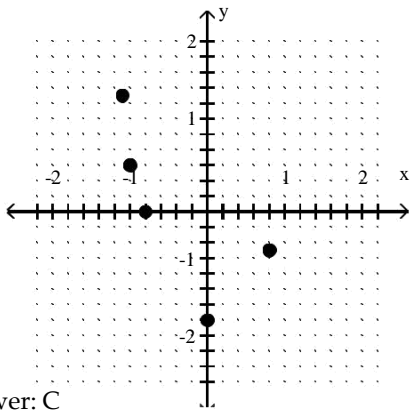

Answer: C

B)

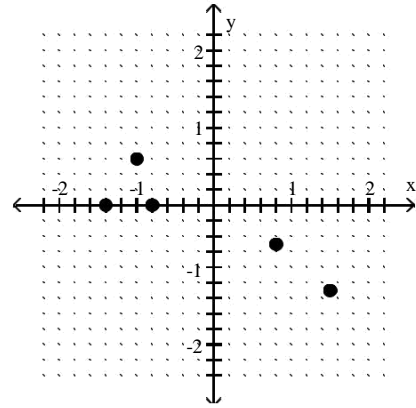

D)

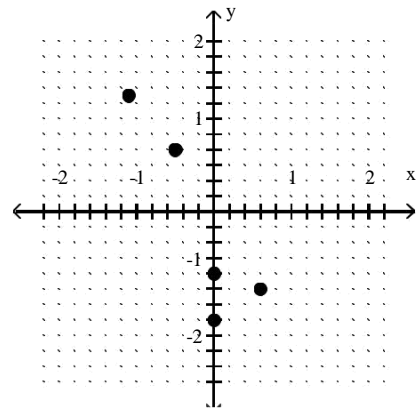

Make a scatterplot of the data.

104) $\{(-1, -8), (-6, -4), (-2, -5), (-5, -5), (-1, 4), (-1, -2), (-6, -7), (9, 1), (-4, -5), (-1, -3)\}$

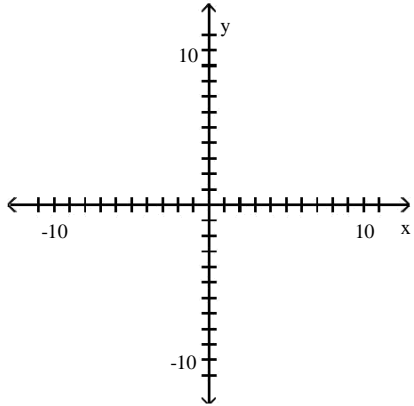

A)

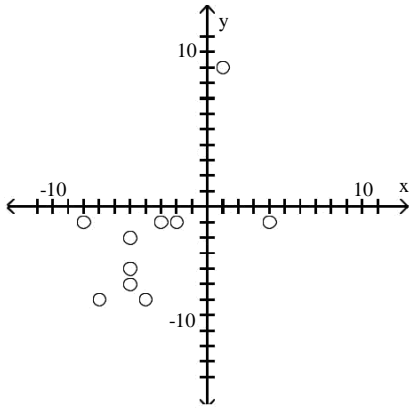

C)

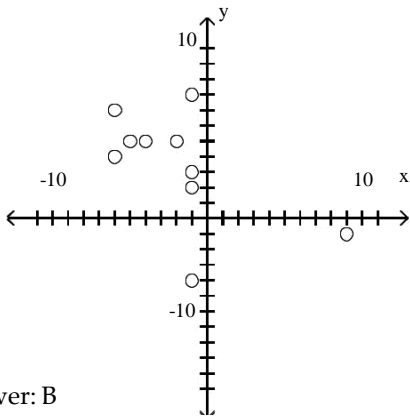

Answer: B

B)

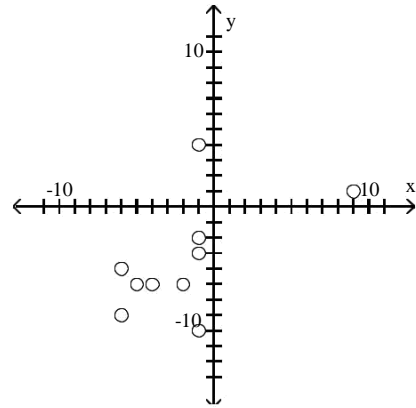

D)

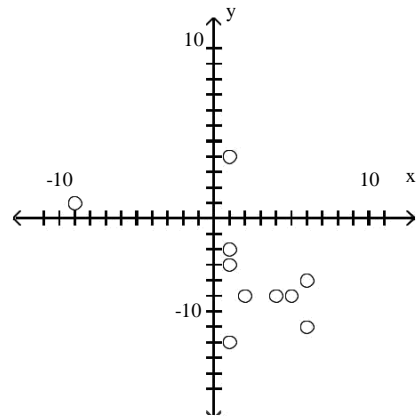

105) $\{(0.7, 0.16), (0.74, 0.34), (0.66, 0.04), (0.52, 0.32), (0.01, -0.85), (0.05, 0.95), (0.07, 0.89), (0.5, 0.24)\}$

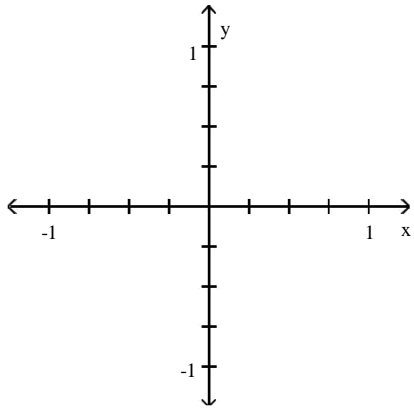

A)

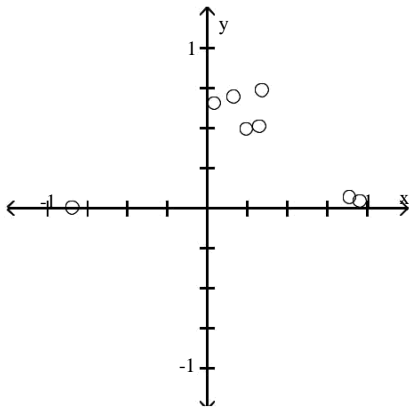

C)

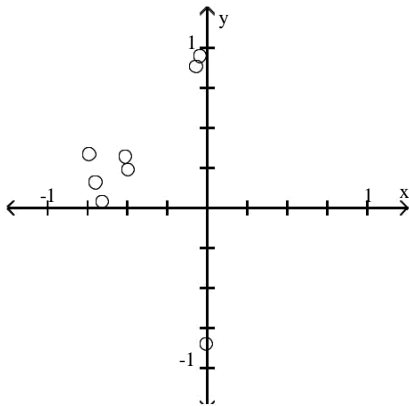

B)

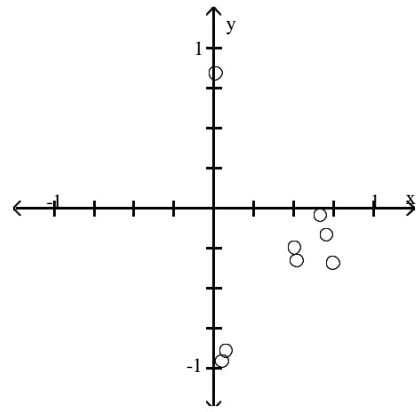

D)

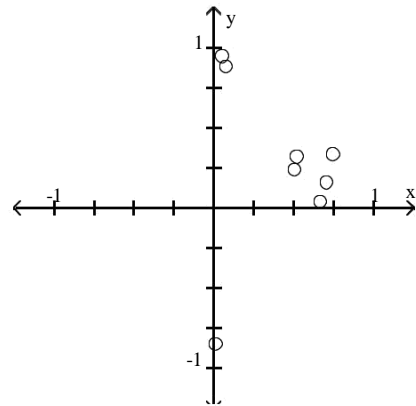

Answer: D

106) $\{(23, 50), (-9, 16), (22, 41), (-9, -16), (-5, -2), (8, 31), (3, 7), (16, 64), (-9, -1), (-5, 6)\}$

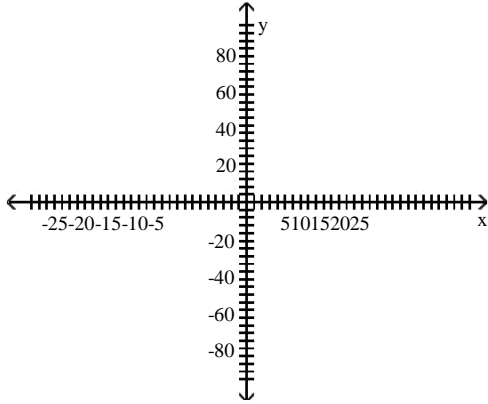

A)

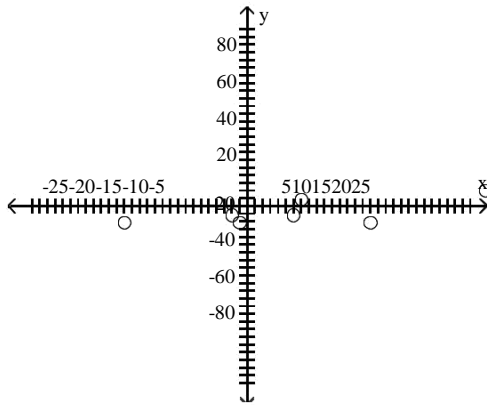

C)

B)

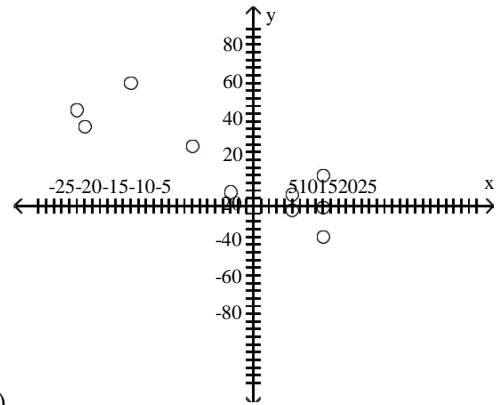

D)

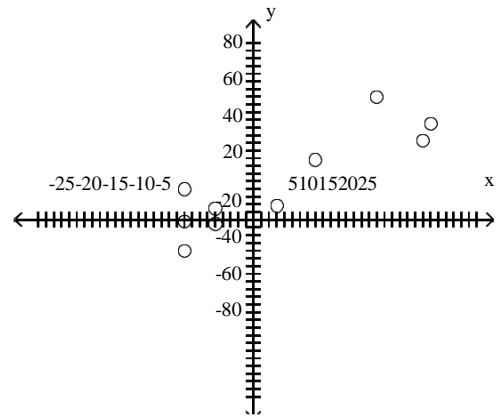
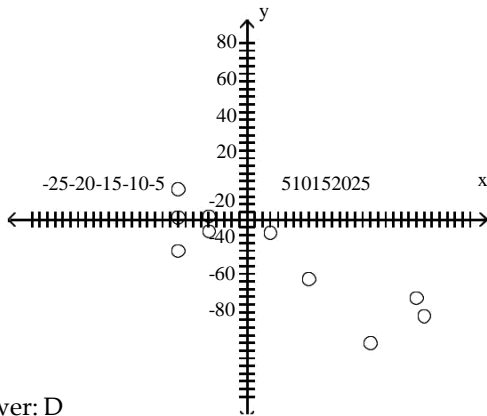

Answer: D

SHORT ANSWER. Write the word or phrase that best completes each statement or answers the question.

Make a line graph of the data.

107) The following table shows the average tuition for one semester at City X College over various years. Use time on the horizontal scale for your line graph.

Year	Average College Tuition
1980	\$1000
1981	1500
1982	2500
1983	3500

Answer: Answers may vary. A possible answer follows.

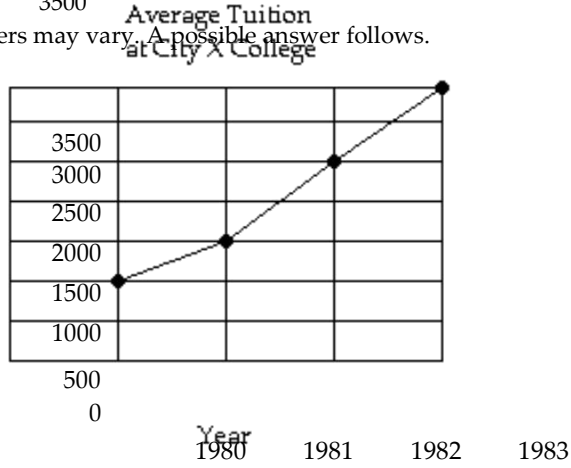

108) The following table shows the number of computer sales made at Computer Buy over five months. Use time on the horizontal scale for your line graph.

Month	Number of Computers Sold
1	213
2	256
3	311
4	527
5	489

Answer: Answers may vary. A possible answer follows.

Computer Sales at
Computer Buy

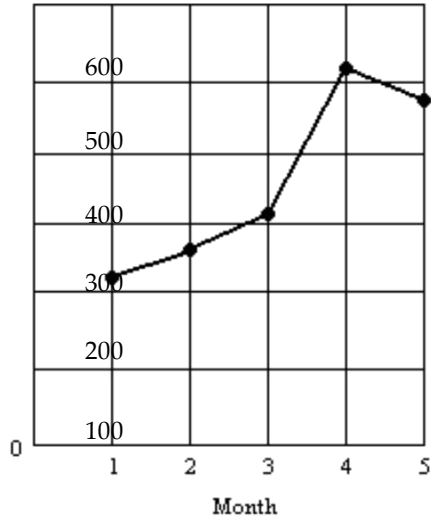

109) The following table shows the median teacher's salary in District X over several years. Use time on the horizontal scale for your line graph.

Year	Average Salary, in thousands
1980	\$53.3
1981	46.5
1982	42.0
1983	69.0
1984	72.8
1985	80.3

Answer: Answers may vary. The following is a possible answer.

Average Teacher's Salary
at District X

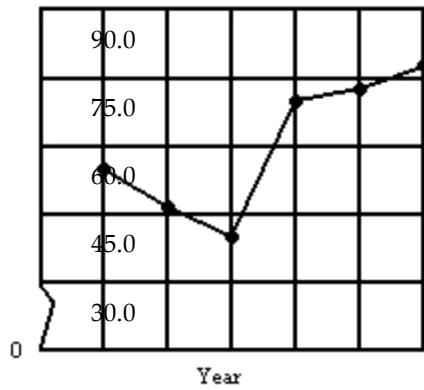

1980 1981 1982 1983 1984 1985

110) The following table gives the average cost of producing a music video over the given years. Use time on the horizontal scale for your line graph.

Year	Production Cost, in millions
1982	\$8.4
1984	7.6
1986	6.0
1988	4.4
1990	3.2
1992	5.6
1994	12.4

Answer: Answers may vary. A possible answer follows.

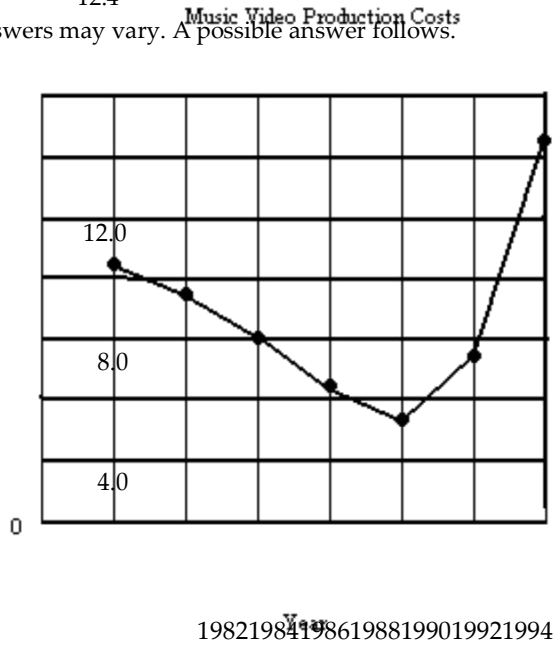

111) The following table gives the total amount of precipitation during the given months. Use time on the horizontal scale for your line graph.

Month	Total Precipitation, in Inches
Nov.	1.52
Dec.	2.72
Jan.	3.76
Feb.	6.04
Mar.	5.56
April	7.44
May	8.28

Answer: Answers may vary. A possible answer follows.

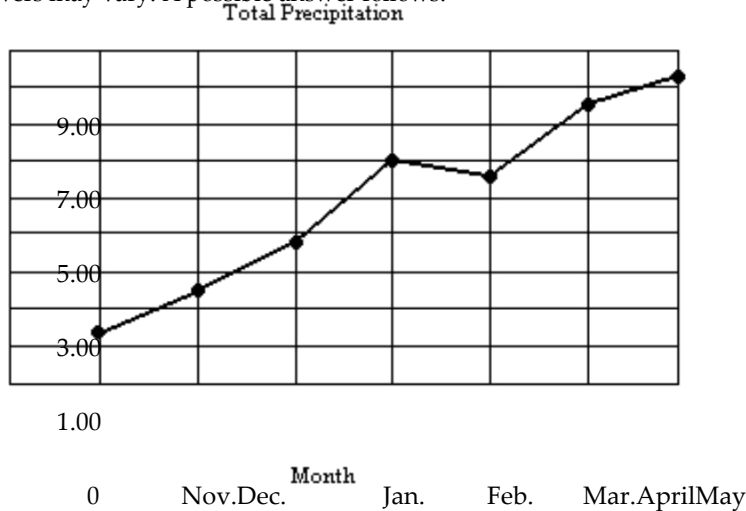

MULTIPLE CHOICE. Choose the one alternative that best completes the statement or answers the question.

Find the center and radius of the circle.

112) $x^2 + y^2 = 16$

- A) Center: (0, 0), radius: 16
- C) Center: (0, 0), radius: 4

- B) Center: (1, 1), radius: 16
- D) Center: (1, 1), radius: 4

Answer: C

113) $x^2 + y^2 = 5$

- A) Center: (1, 1), radius: 5
- C) Center: (1, 1), radius: $5\sqrt{}$

- B) Center: (0, 0), radius: $5\sqrt{}$
- D) Center: (0, 0), radius: 5

Answer: B

114) $(x + 5)^2 + (y + 4)^2 = 4$

- A) Center: (-4, -5), radius = 2
- C) Center: (-5, -4), radius = 2

- B) Center: (4, 5), radius = 4
- D) Center: (5, 4), radius = 4

Answer: C

115) $x^2 + (y - 7)^2 = 25$

- A) Center: (0, 7), radius = 5
C) Center: (0, -7), radius = 5

Answer: A

- B) Center: (7, 0), radius = 5
D) Center: (0, 7), radius = 25

116) $(x - 1)^2 + y^2 = 81$

- A) Center: (-1, 0), radius = 9
C) Center: (0, 1), radius = 9

Answer: D

- B) Center: (1, 0), radius = 81
D) Center: (1, 0), radius = 9

117) $6x^2 + 6y^2 = 36$

- A) Center: (0, 0), radius: 6
C) Center: (6, 6), radius: $6\sqrt{}$

Answer: D

- B) Center: (0, 0), radius: 36
D) Center: (0, 0), radius: $6\sqrt{}$

118) $x^2 - 10x + 25 + y^2 - 4y + 4 = 64$ A)

(5, 2), r = 8

Answer: A

B) (-5, -2), r = 64

C) (2, 5), r = 8

D) (-2, -5), r = 64

119) $x^2 + y^2 - 16x + 8y + 80 = 36$ A)

(8, -4), r = 6

Answer: A

B) (4, -8), r = 36

C) (-4, 8), r = 6

D) (-8, 4), r = 36

120) $x^2 + y^2 - 18x - 8y = -72$ A)

(-9, -4), r = 25

Answer: D

B) (-4, -9), r = 25

C) (4, 9), r = 5

D) (9, 4), r = 5

121) $x^2 + y^2 = 2x + 63$ A)

(-1, 0), r = 8

Answer: C

B) (-1, 0), r = 64

C) (1, 0), r = 8

D) (1, 0), r = 64

122) $x^2 + 10x + y^2 + 16y + 25 = 0$ A)

(5, 8), r = 8

Answer: C

B) (-5, -8), r = 64

C) (-5, -8), r = 8

D) (5, 8), r = 64

Use the graph to find the standard equation of the circle.

123)

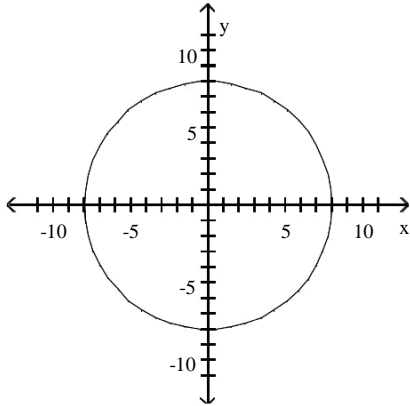

A) $x^2 + y^2 = 16$

B) $x^2 + y^2 = 8$

C) $x^2 + y^2 = 36$

D) $x^2 + y^2 = 64$

Answer: D

124)

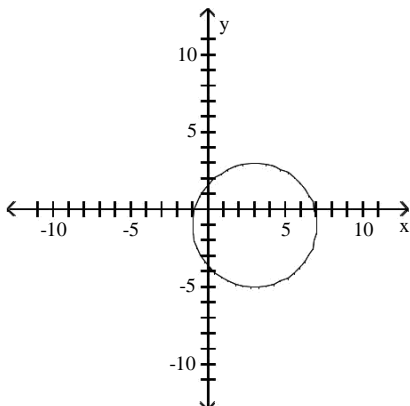

A) $(x + 3)^2 + (y - 1)^2 = 4$

B) $(x - 3)^2 + (y + 1)^2 = 16$

C) $(x - 3)^2 + (y + 1)^2 = 4$

D) $(x + 3)^2 + (y - 1)^2 = 16$

Answer: B

125)

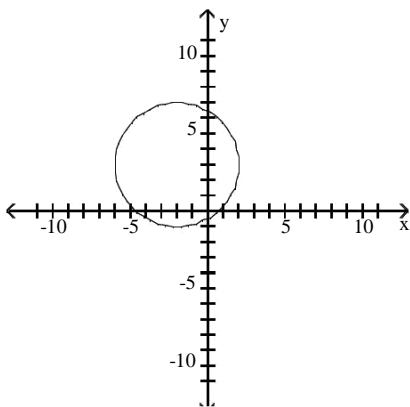

A) $(x + 2)^2 + (y - 3)^2 = 16$

B) $(x + 2)^2 + (y - 3)^2 = 4$

C) $(x - 2)^2 + (y + 3)^2 = 4$

D) $(x - 2)^2 + (y + 3)^2 = 16$

Answer: A

126)

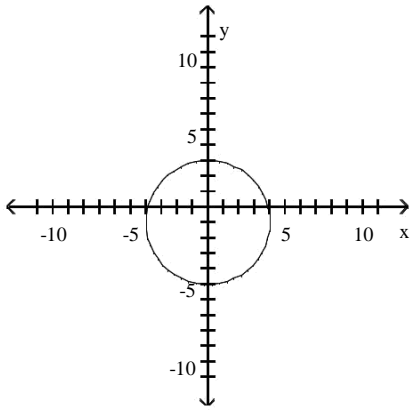

A) $x^2 + (y + 1)^2 = 4$

B) $x^2 + (y - 1)^2 = 16$

C) $(x + 1)^2 + y^2 = 16$

D) $x^2 + (y + 1)^2 = 16$

Answer: D

127)

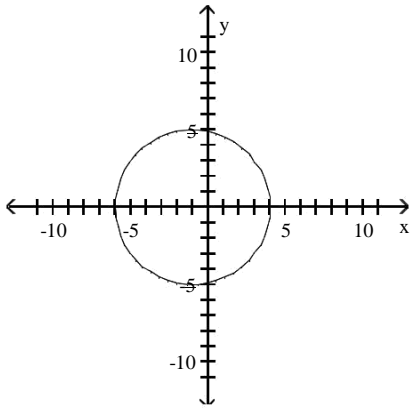

A) $(x + 1)^2 + y^2 = 25$

B) $(x + 1)^2 + y^2 = 5$

C) $x^2 + (y + 1)^2 = 25$

D) $(x - 1)^2 + y^2 = 25$

Answer: A

Find the standard equation of the circle that satisfies the conditions.

128) Center $(-8, -10)$, radius 9

A) $(x - 8)^2 + (y - 10)^2 = 81$

B) $(x + 10)^2 + (y + 8)^2 = 9$

C) $(x - 10)^2 + (y - 8)^2 = 9$

D) $(x + 8)^2 + (y + 10)^2 = 81$

Answer: D

129) Center $(5, -3)$, radius $11\sqrt{11}$

A) $(x - 5)^2 + (y + 3)^2 = 11$

B) $(x + 5)^2 + (y - 3)^2 = 11$

C) $(x - 3)^2 + (y + 5)^2 = 121$

D) $(x + 3)^2 + (y - 5)^2 = 121$

Answer: A

130) Center $(-9, 0)$, radius 5

A) $x^2 + (y - 9)^2 = 5$

B) $(x + 9)^2 + y^2 = 25$

C) $x^2 + (y + 9)^2 = 5$

D) $(x - 9)^2 + y^2 = 25$

Answer: B

131) Center (0, 0), radius 10

A) $(x - 10)^2 + (y - 10)^2 = 100$

C) $x^2 + y^2 = 10$

Answer: D

B) $x^2 + y^2 = 10 \sqrt{\quad}$

D) $x^2 + y^2 = 100$

132) Center (6, -9) with the point (9, -5) on the circle A)

$(x - 9)^2 + (y + 6)^2 = 9$

C) $(x + 6)^2 + (y - 9)^2 = 25$

Answer: D

B) $(x + 9)^2 + (y - 6)^2 = 9$

D) $(x - 6)^2 + (y + 9)^2 = 25$

133) Endpoints of a diameter (6, 5) and (-5, 3)

A) $x \left[\begin{matrix} 1 \\ 2 \end{matrix} \right]^2 + (y + 4)^2 = 65$

C) $x \left[\begin{matrix} 11 \\ 2 \end{matrix} \right]^2 + (y - 1)^2 = 125$

Answer: D

B) $x \left[\begin{matrix} 1 \\ 2 \end{matrix} \right]^2 + (y - 4)^2 = 5$

D) $x \left[\begin{matrix} 1 \\ 2 \end{matrix} \right]^2 + (y - 4)^2 = \frac{125}{4}$

Provide the requested response.

134) For the viewing rectangle [-10, 10, 2] by [-8, 8, 2], state the number of tick marks on the positive x-axis.

A) 8

B) 4

C) 10

D) 5

Answer: D

135) For the viewing rectangle [0, 14, 2] by [0, 22, 2], state the number of tick marks on the positive y-axis. A) 22

B) 14

C) 11

D) 7

Answer: C

136) For the viewing rectangle [-35, 35, 5] by [0, 25, 5], state the number of tick marks on the positive x-axis. A) 9

B) 5

C) 7

D) 12

Answer: C

137) For the viewing rectangle [1970, 2010, 10] by [13,000, 29,000, 1000], state the number of tick marks on the positive x-axis.

A) 2

B) 8

C) 7

D) 5

Answer: D

138) For the viewing rectangle [1970, 2010, 10] by [13,000, 27,000, 1000], state the number of tick marks on the positive y-axis.

A) 10

B) 21

C) 15

D) 17

Answer: C

139) Choose the correct viewing rectangle to match the settings: $[-8, 8, 1]$ by $[-8, 8, 1]$.

A)

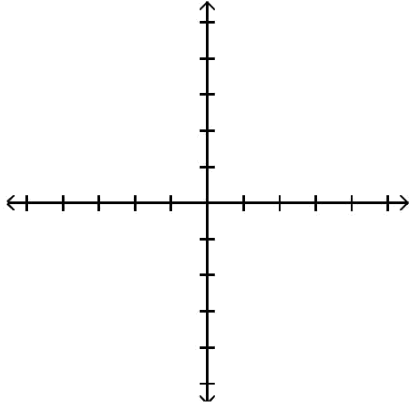

B)

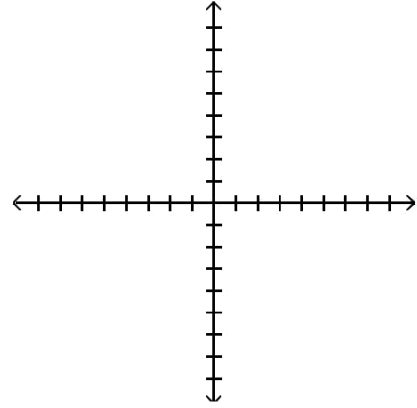

C)

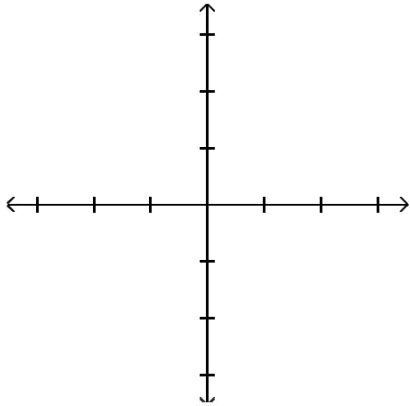

D)

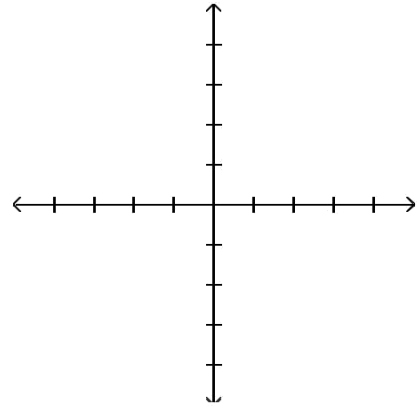

Answer: B

140) Choose the correct viewing rectangle to match the settings: $[-3, 7, 1]$ by $[-5, 8, 1]$.

A)

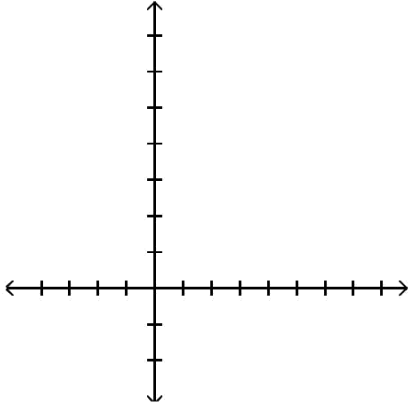

B)

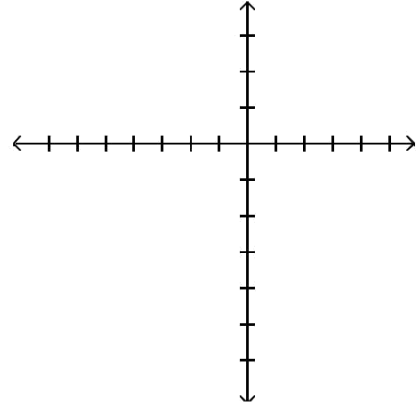

C)

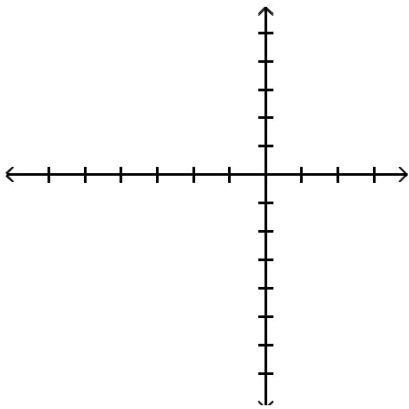

D)

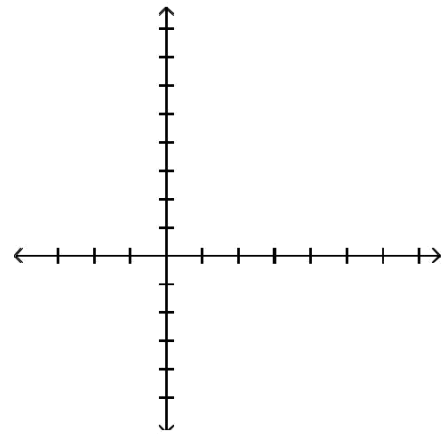

Answer: D

141) Choose the correct viewing rectangle to match the settings: $[-200, 200, 50]$ by $[-100, 100, 20]$.

A)

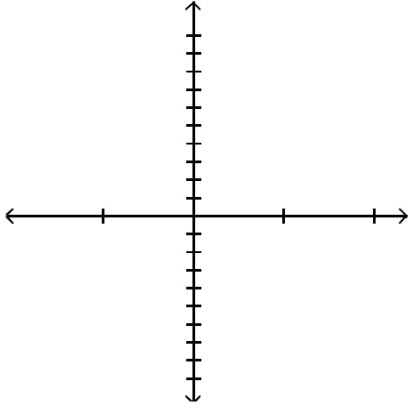

B)

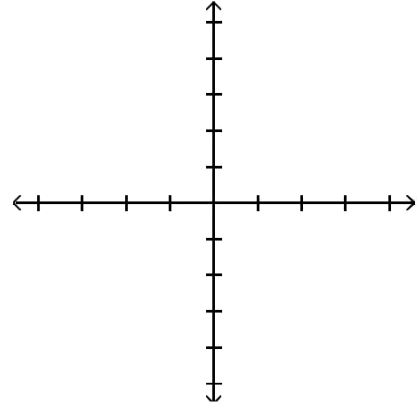

C)

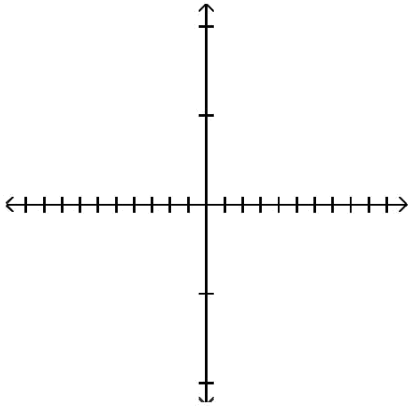

D)

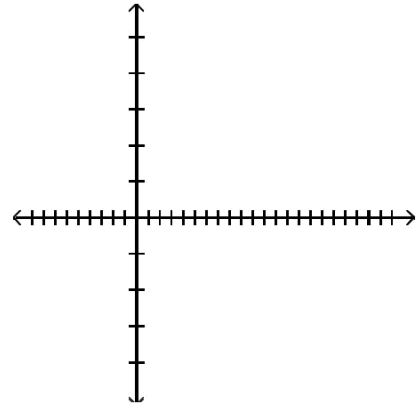

Answer: B

142) Choose the correct viewing rectangle to match the settings: $[-2, 10, 1]$ by $[-4, 8, 1]$

A)

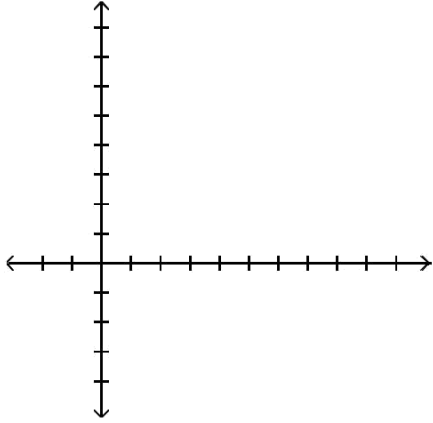

B)

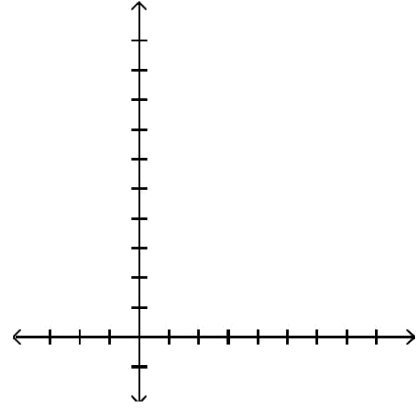

C)

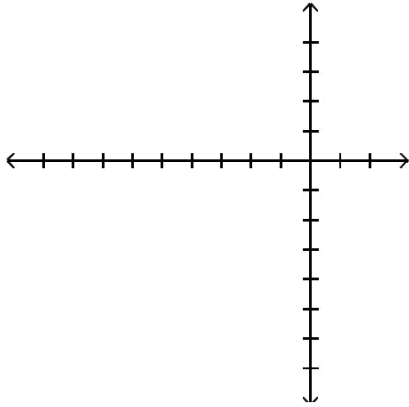

D)

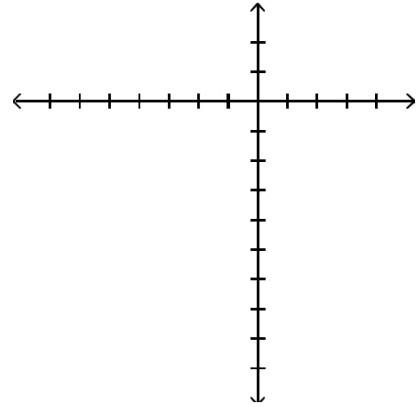

Answer: A

143) Choose the correct viewing rectangle to match the settings: $[-2, 10, 2]$ by $[-4, 12, 4]$

A)

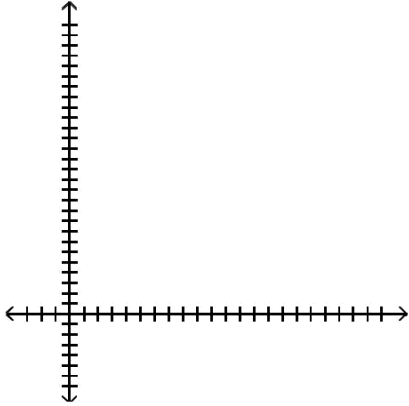

B)

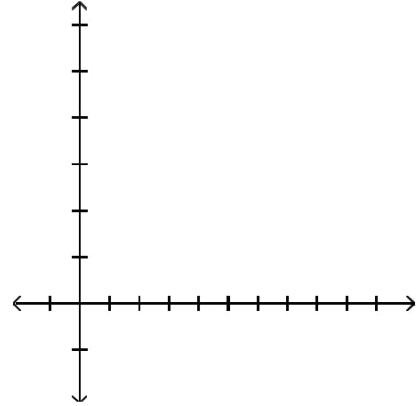

C)

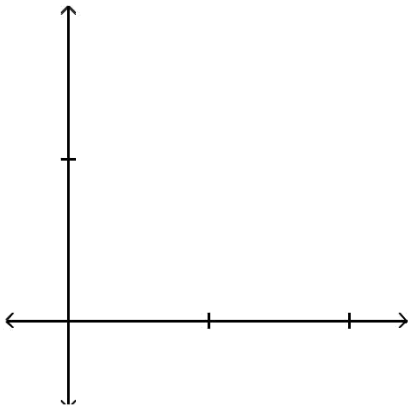

D)

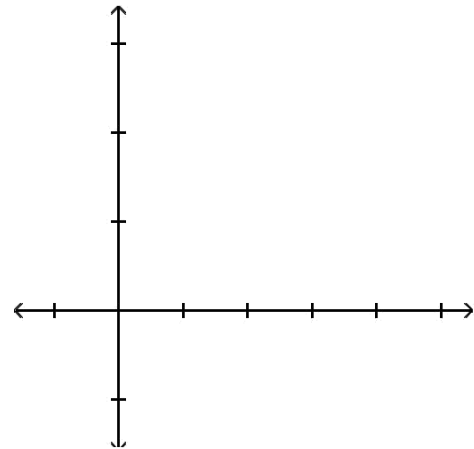

Answer: D

144) If $f(-9) = -7$ identify a point on the graph of f . A)

(9, -7)

B) (-9, 7)

C) (-9, -7)

D) (-7, -9)

Answer: C

145) If the point $(-1, 9.1)$ lies on the graph of f , then $f(\underline{\quad}) = \underline{\quad}$. A)

$f(-1) = 0$

B) $f(-1) = 9.1$

C) $f(0) = 9.1$

D) $f(9.1) = -1$

Answer: B

Graph f by hand by first plotting points to determine the shape of the graph.

146) $f(x) = 4x + 6$

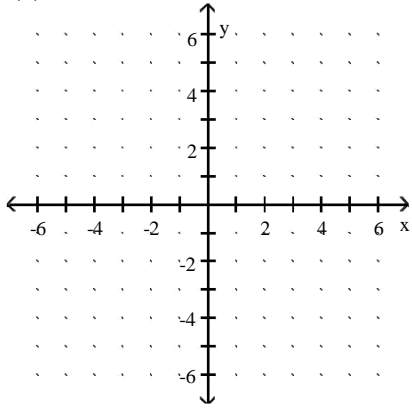

A)

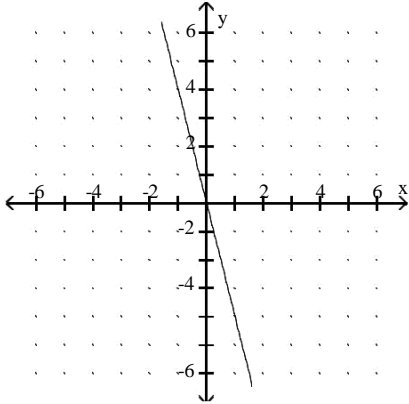

B)

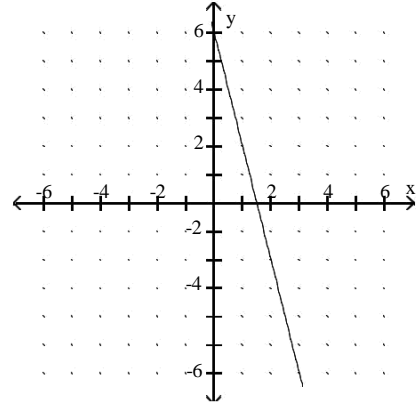

C)

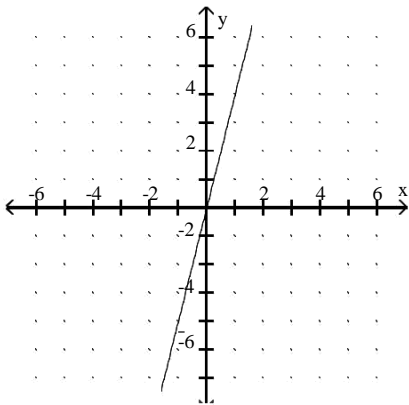

D)

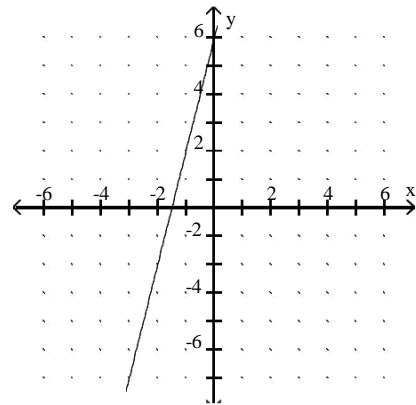

Answer: D

147) $f(x) = x - 3$

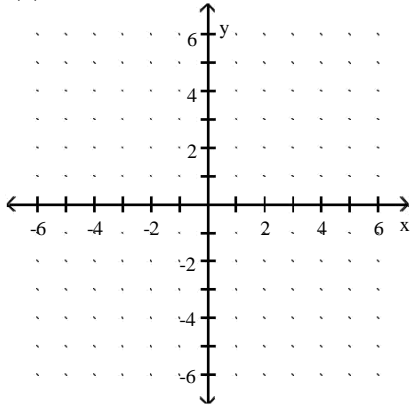

A)

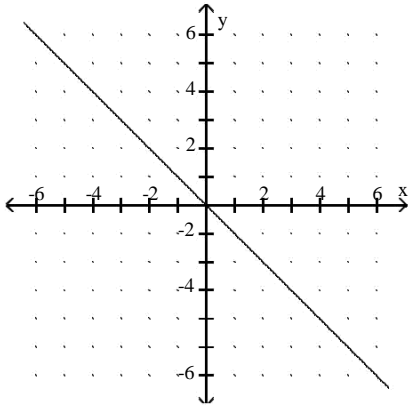

B)

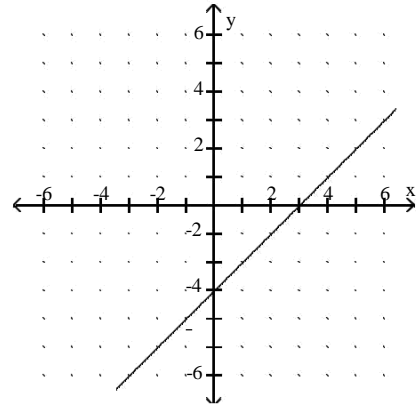

C)

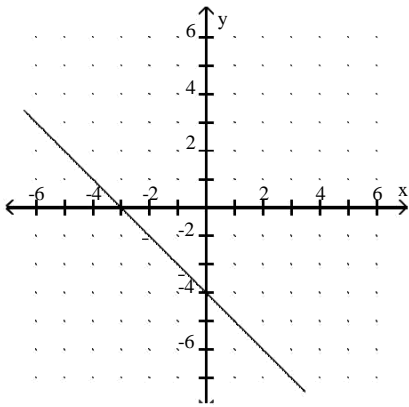

D)

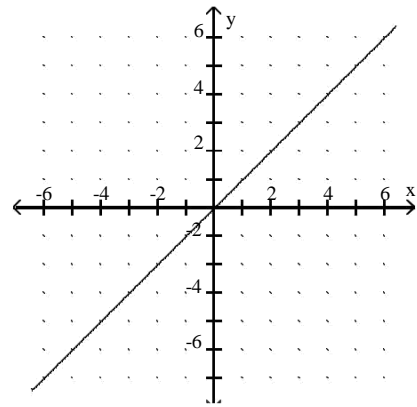

Answer: B

148) $f(x) = 2x$

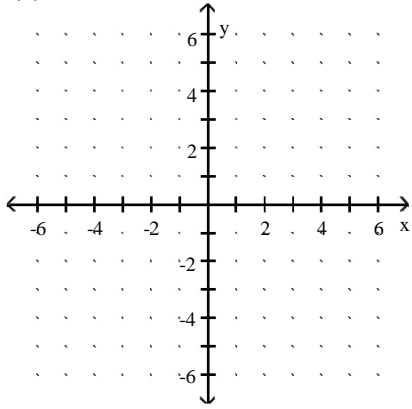

A)

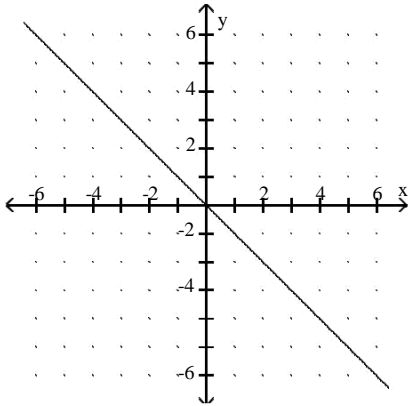

B)

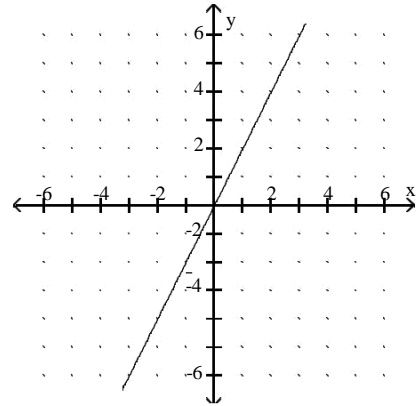

C)

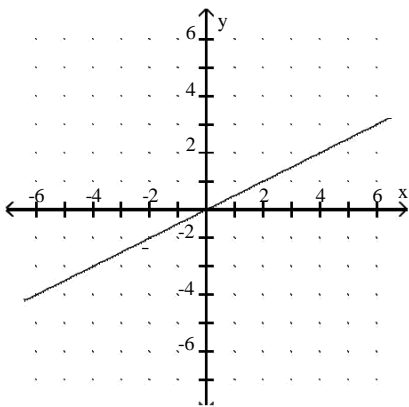

D)

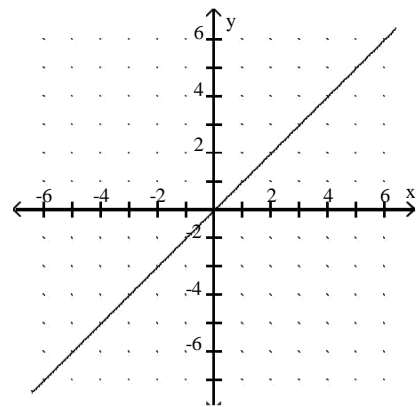

Answer: B

149) $f(x) = \frac{1}{3}x + 6$

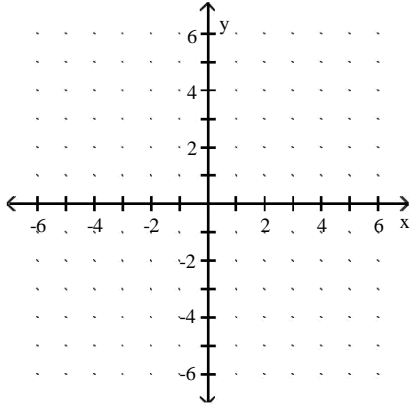

A)

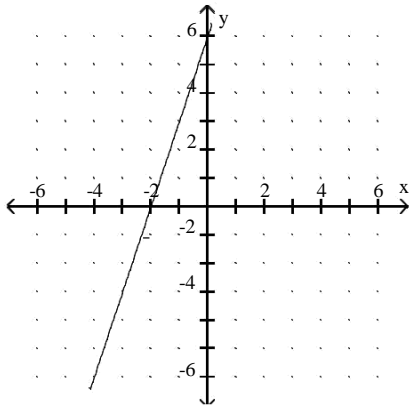

C)

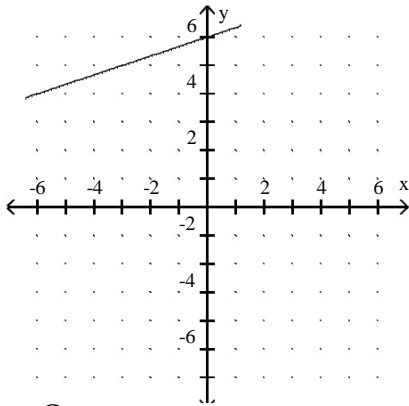

Answer: C

B)

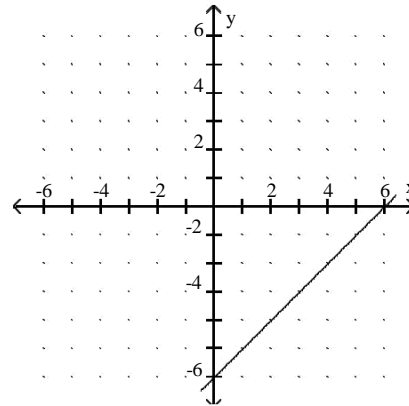

D)

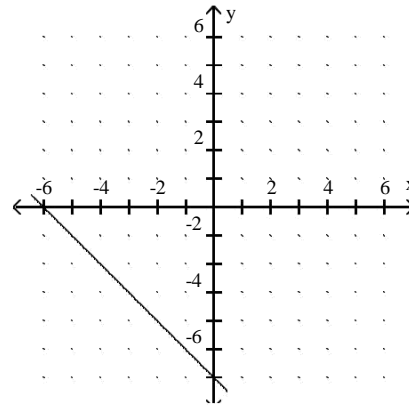

150) $f(x) = \frac{1}{3^x}$

3^x

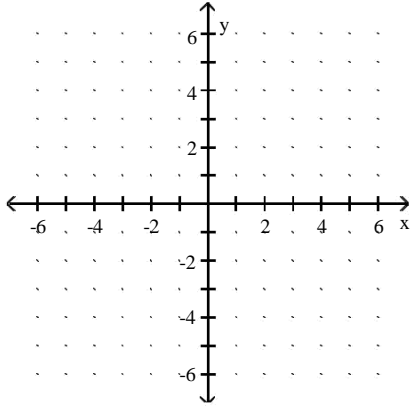

A)

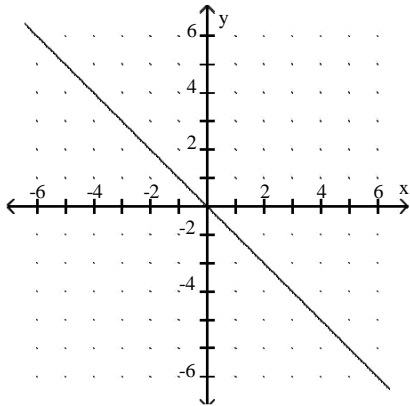

B)

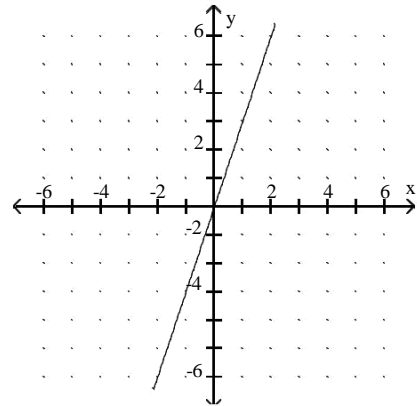

C)

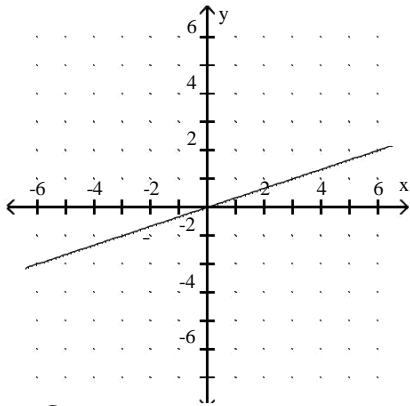

D)

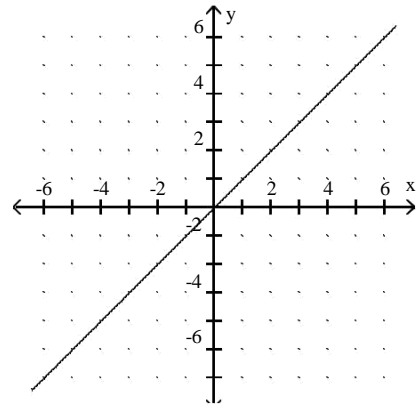

Answer: C

151) $f(x) = -3$

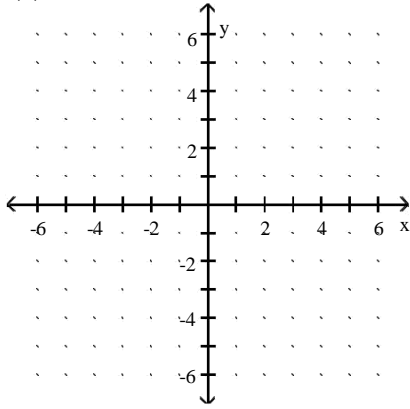

A)

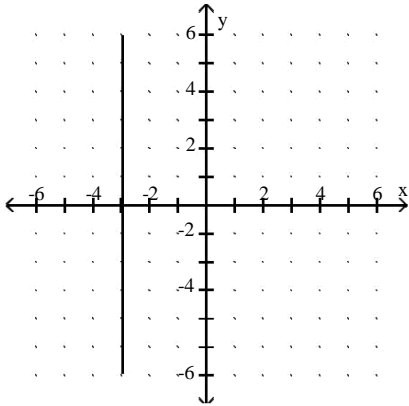

C)

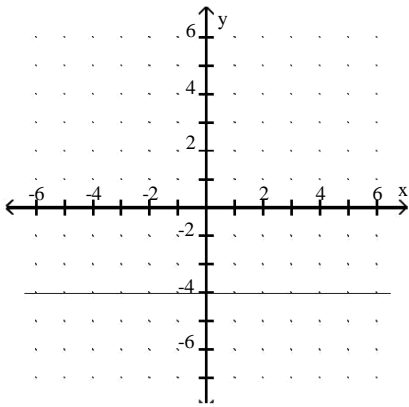

Answer: C

B)

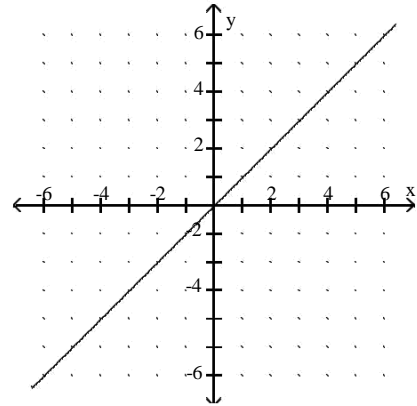

D)

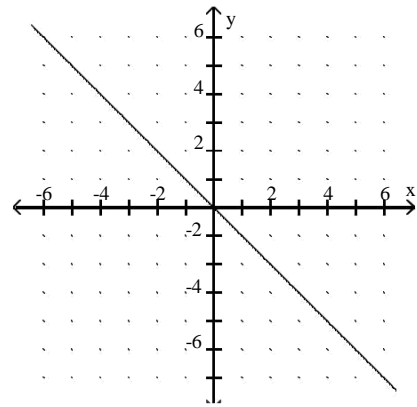

152) $f(x) = |x + 2|$

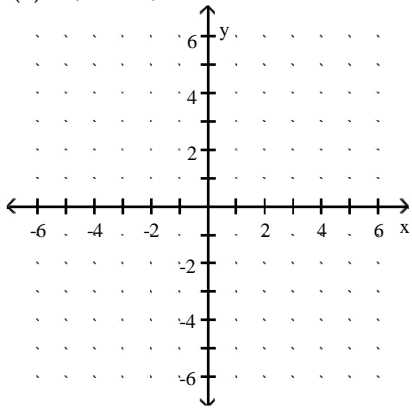

A)

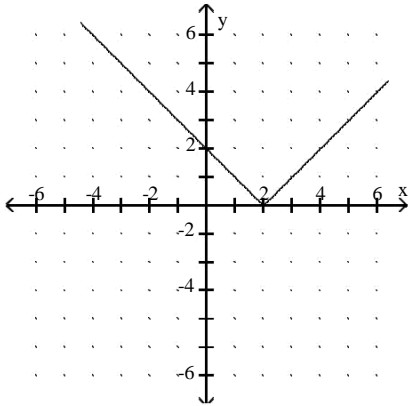

B)

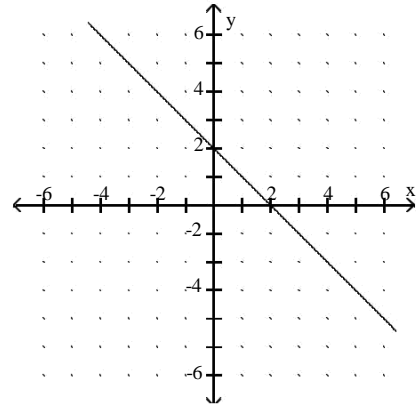

C)

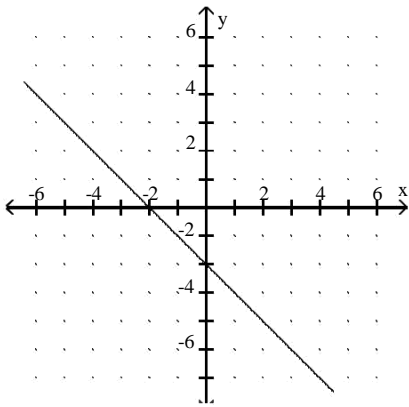

D)

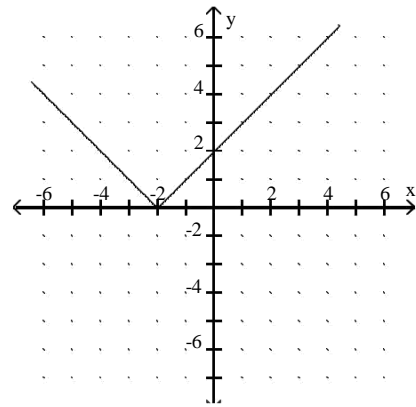

Answer: D

153) $f(x) = \frac{1}{2^x}$

2

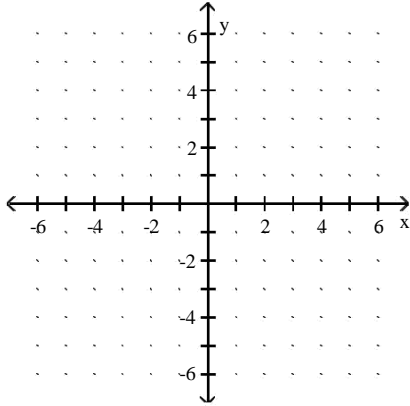

A)

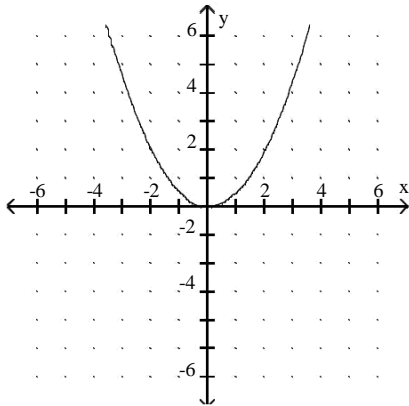

B)

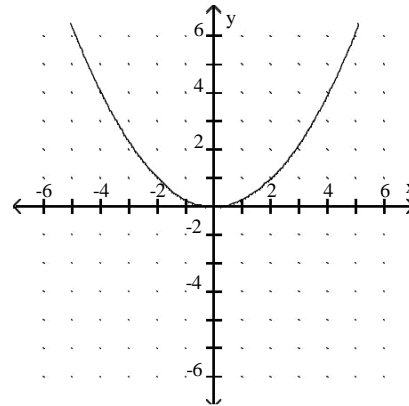

C)

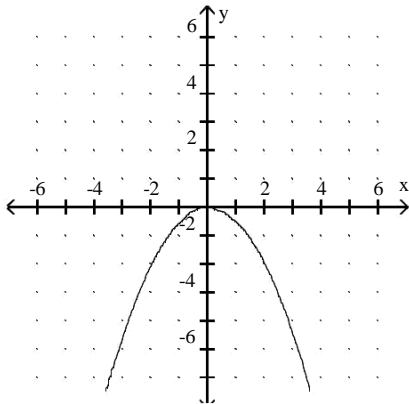

D)

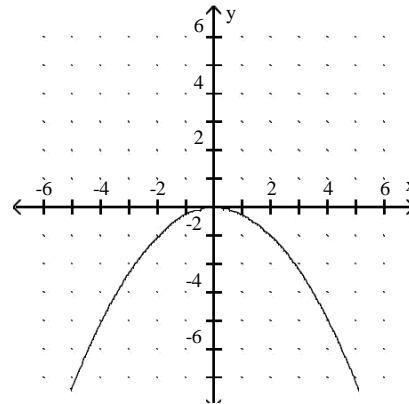

Answer: A

154) $f(x) = x\sqrt{\quad}$

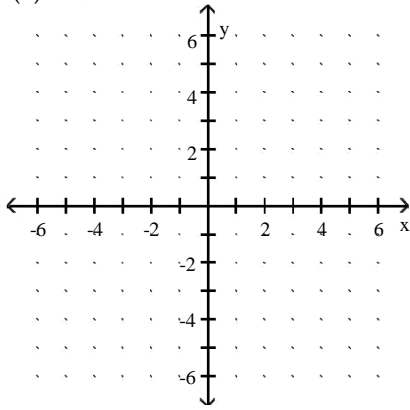

A)

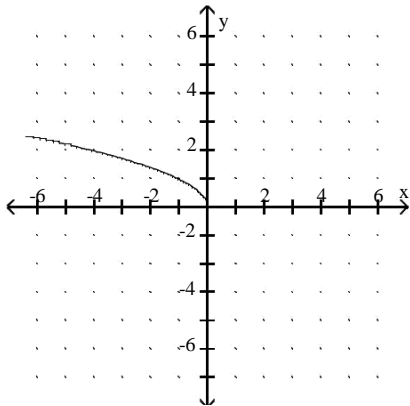

C)

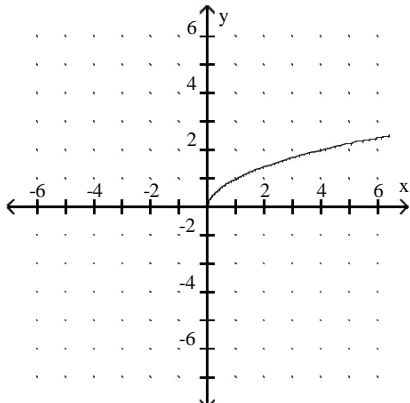

Answer: C

B)

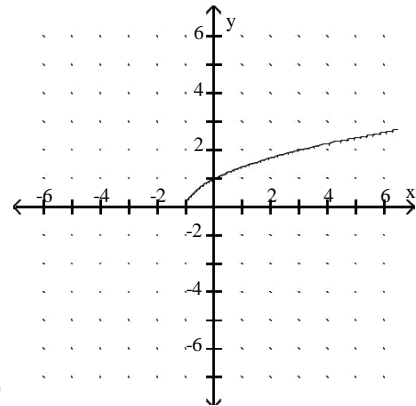

D)

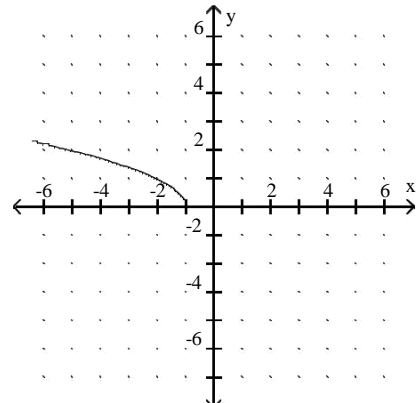

155) $f(x) = 5x^2$

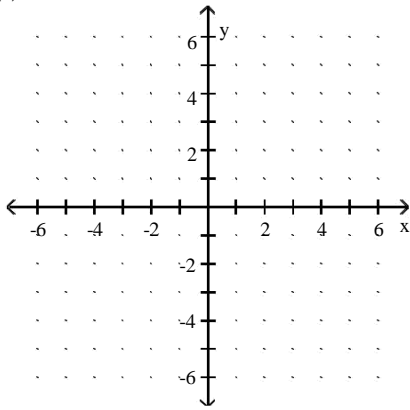

A)

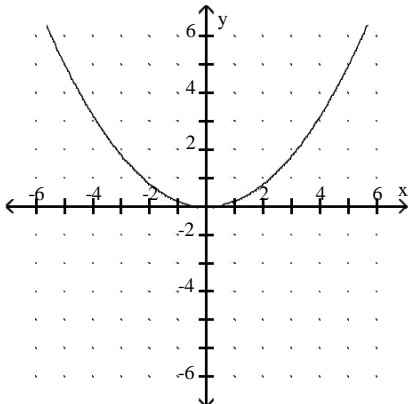

C)

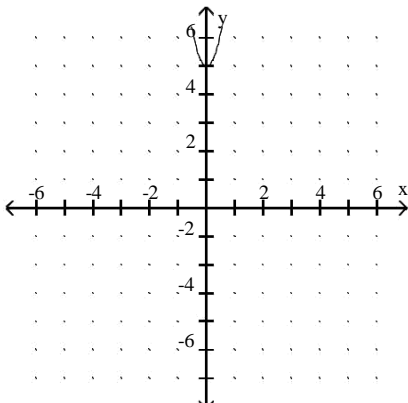

B)

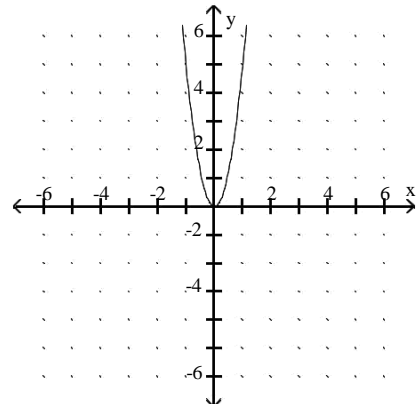

D)

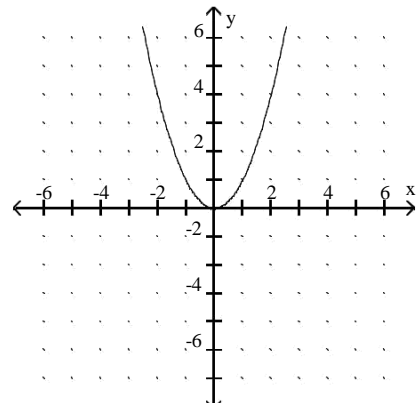

Answer: B

Evaluate the function as indicated.

156) Find $f(16)$ when $f(x) = -19x - 8$.

A) 296

B) -312

C) -304.8

D) -296

Answer: B

157) Find $g(a - 1)$ when $g(x) = 2x - 1$.

A) $2a - 3$

B) $2a - 1$

C) $\frac{1}{2a - 1}$

D) $2a + 1$

Answer: A

158) Find $f(-1.3)$ when $f(x) = -19$.

A) -19

B) -1.3

C) 24.7

D) 19

Answer: A

159) Find $f(-4)$ when $f(x) = x^2 - 2x - 6$. A)

2

B) 14

C) 18

D) 30

Answer: C

160) Find $f(k - 1)$ when $f(x) = 5x^2 + 5x + 6$. A)

$5k^2 + 35k + 16$

B) $5k^2 - 5k + 6$

C) $-5k^2 + 5k + 6$

D) $5k^2 - 5k + 16$

Answer: B

161) Find $f(8)$ when $f(x) = 3\sqrt{x+5}$.

A) $13\sqrt{}$

B) $29\sqrt{}$

C) $8\sqrt{}$

D) $23\sqrt{}$

Answer: B

162) Find $f(t+2)$ when $f(x) = 4\sqrt{x+3}$.

A) $4\sqrt{t+11}$

B) $4\sqrt{t+3}$

C) $4\sqrt{t+15}$

D) $2\sqrt{t+11}$

Answer: A

163) Find $f(-2)$ when $f(x) = \frac{x-6}{x+1}$.

A) -8

B) 8

C) -4

D) $\frac{8}{3}$

Answer: B

Specify the domain of the function.

164) $f(x) = 6x - 1$

A) $x \neq 0$

B) $x > 0$

C) $x = 1$

D) All real numbers

Answer: D

165) $f(x) = 7x^2 + 9x - 7$

A) $x > 0$

B) $x \neq 0$

C) All real numbers

D) $x < 0$

Answer: C

166) $f(x) = 5\sqrt{x}$

A) $x \neq 5$

B) $x = 5$

C) All real numbers

D) $x > 5\sqrt{}$

Answer: B

167) $f(x) = \frac{(x+7)(x-7)}{x^2 - 49}$

A) $x > 49$

B) $x \neq 7, x \neq -7$

C) All real numbers

D) $x \neq 49$

Answer: B

168) $f(x) = \frac{x}{x-5}$

A) All real numbers

B) $x \neq 5$

C) $x > 0$

D) $x \neq -5$

Answer: B

169) $f(x) = \frac{(x+1)(x-1)}{x^2+1}$

A) $x \neq 1$

B) $x \neq 1, x \neq -1$

C) $x > 1$

D) All real numbers

Answer: D

170) $f(x) = \frac{\sqrt{x+4}}{(x+4)(x-4)}$

A) $x = -4, x \neq -4, x \neq 4$

B) All real numbers

C) $x > 0$

D) $x \neq -4, x \neq -4, x \neq 4$

Answer: A

171) $f(x) = -2$

A) $x = -2$

B) All real numbers

C) $x = 0$

D) $x \neq -2$

Answer: B

Find the domain and the range for the function.

172)

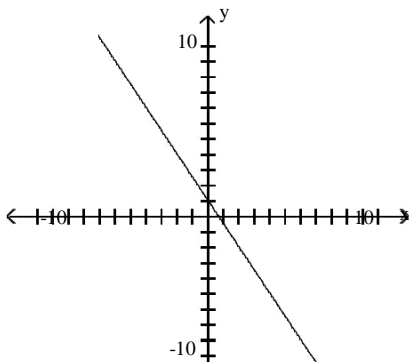

A) D: $\{x \mid x = 2\}$, R: $\{y \mid y = 0\}$

B) D: $\{x \mid x = 2\}$, R: $\{y \mid y = 0\}$

C) D: All real numbers, R: All real numbers

D) D: $\{x \mid x = 0\}$, R: $\{y \mid y = -\}$

Answer: C

173)

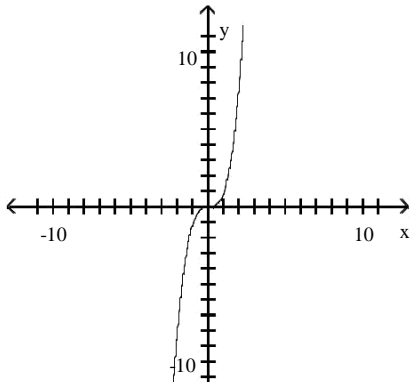

- A) D: $\{x|x > 0\}$, R: $\{y|y > 0\}$
 C) D: $\{x|x = 0\}$, R: $\{y|y = 0\}$
 Answer: D

- B) D: $\{x|x = 0\}$, R: $\{y|y = 0\}$
 D) D: All real numbers, R: All real numbers

174)

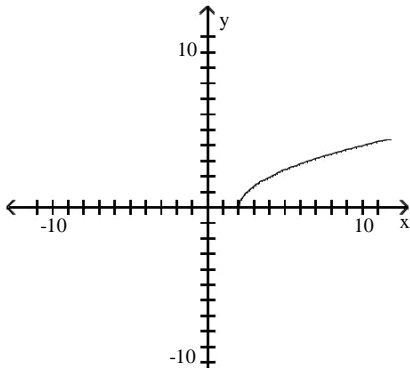

- A) D: $\{x|x = 0\}$, R: $\{y|y = 0\}$
 C) D: $\{x|x = 2\}$, R: $\{y|y = 1\}$
 Answer: C

- B) D: $\{x|x > 2\}$, R: $\{y|y = 1\}$
 D) D: $\{x|x > 0\}$, R: $\{y|y < 0\}$

175)

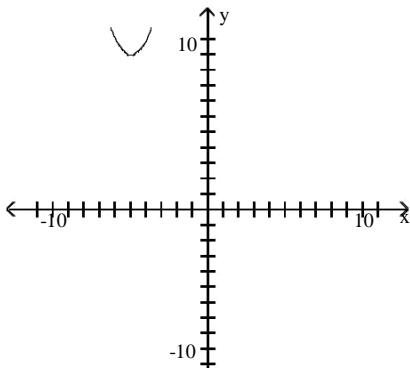

- A) D: $\{x|x < 0\}$, R: $\{y|y < 10\}$
 C) D: $\{x|x > 0\}$, R: $\{y|y = 10\}$
 Answer: B

- B) D: All real numbers, R: $\{y|y = 10\}$
 D) D: $\{x|x < 0 \text{ or } x > 0\}$, R: $\{y|y < 0 \text{ or } y > 0\}$

176)

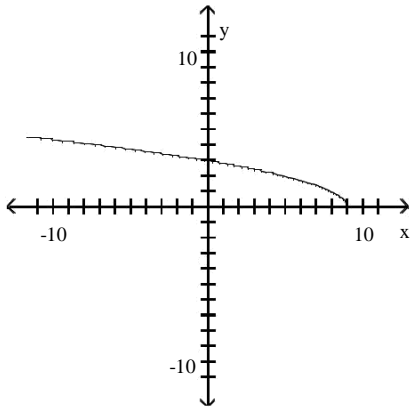

A) D: All real numbers, R: $\{y = 0\}$

C) D: $\{x|x < 9\}$, R: $\{y = \dots\}$

Answer: B

B) D: $\{x|x = 9\}$, R: $\{y = \dots\}$

D) D: $\{x|x < 9 \text{ or } x > 9\}$, R: $\{y|y < 0 \text{ or } y > 0\}$

177)

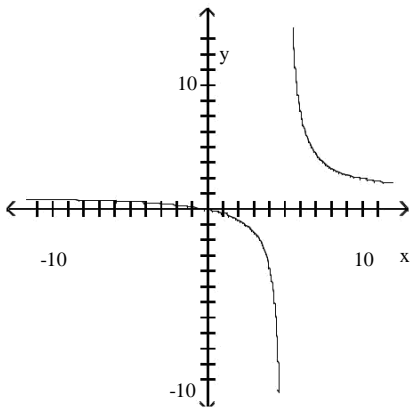

A) D: $\{x|x < 5 \text{ or } x > 5\}$, R: $\{y|y < 1 \text{ or } y > 1\}$

C) D: All real numbers, R: All real numbers

Answer: A

B) D: $\{x|x > 0\}$, R: $\{y > \dots\}$

D) D: $\{x|x < -5 \text{ or } x > -5\}$, R: All real numbers

178)

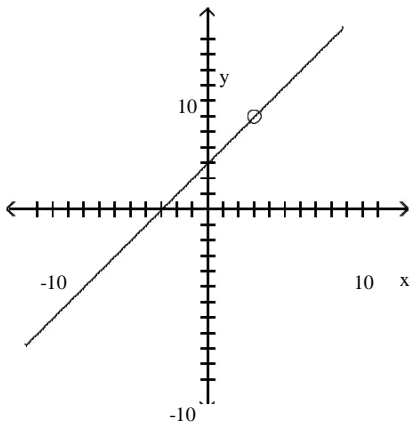

A) D: All real numbers, R: All real numbers

B) D: $\{x|x < 3 \text{ or } x > 3\}$, R: $\{y|y < 6 \text{ or } y > 6\}$

C) D: $\{x|x < -3 \text{ or } x > -3\}$, R: $\{y|y < -6 \text{ or } y > -6\}$

D) D: $\{x|x < 6 \text{ or } x > 6\}$, R: $\{y|y < 3 \text{ or } y > 3\}$

3 Answer: B

179)

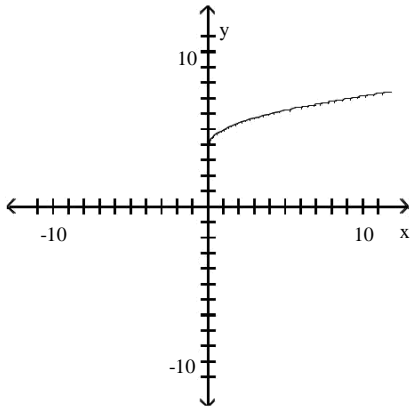

A) D: $\{x|x=0\}$, R: $\{y|y= \}$

C) D: $\{x|x=0\}$, R: $\{y|y= \}$

Answer: C

B) D: $\{x|x=-4\}$, R: $\{y|y= \}$

D) D: $\{x|x=4\}$, R: $\{y|y= \}$

0

180)

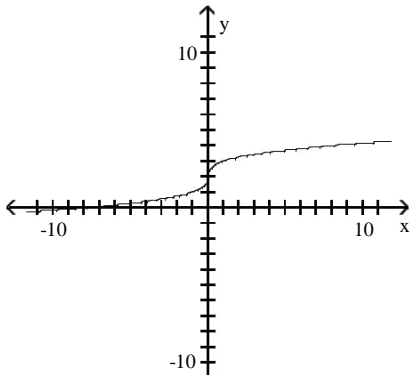

A) D: $\{x|x>0\}$, R: $\{y|y= \}$

C) D: $\{x|x>4\}$, R: $\{y|y= \}$

Answer: D

B) D: $\{x|x>2\}$, R: $\{y|y= \}$

D) D: All real numbers, R: All real numbers

Use the graph to evaluate the function value.

181) $f(-1)$

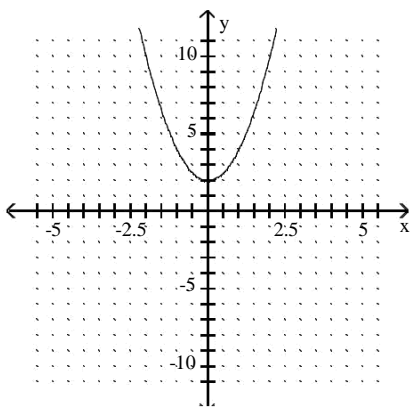

A) -1

B) 0

C) 4

D) 2

Answer: C

For the given function expressed verbally, give a graphical representation.

182) To convert x inches to y centimeters, multiply x by 2.54. Let $y = f(x)$ and $0 \leq x \leq 50$.

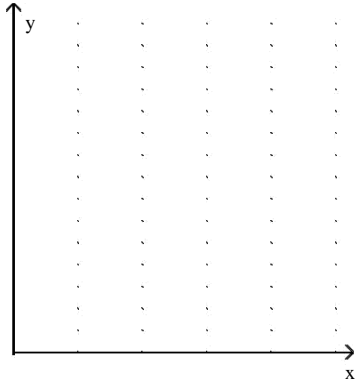

A)

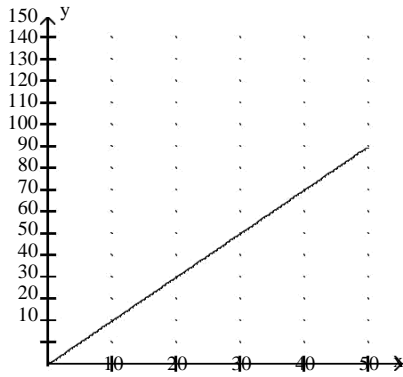

B)

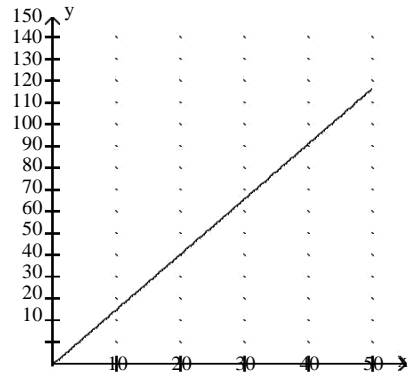

C)

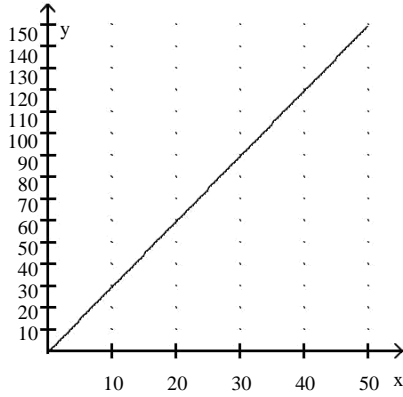

D)

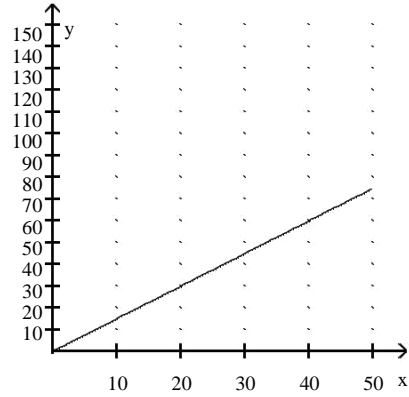

Answer: B

183) To convert x centimeters to y inches, divide x by 2.54. Let $y = f(x)$ and $0 \leq x \leq 15$.

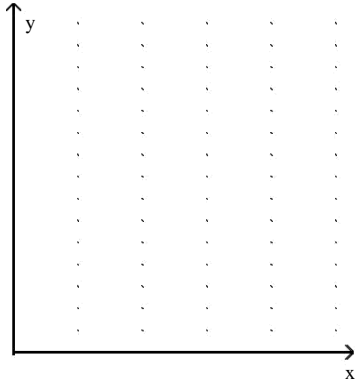

A)

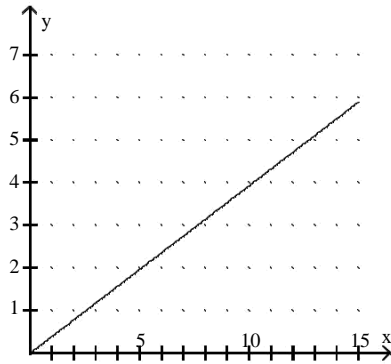

B)

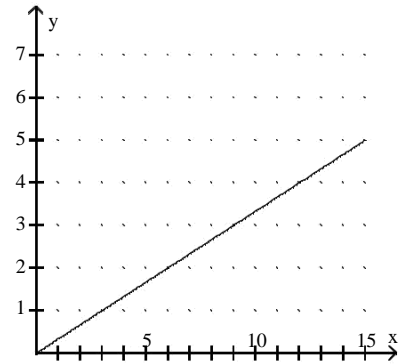

C)

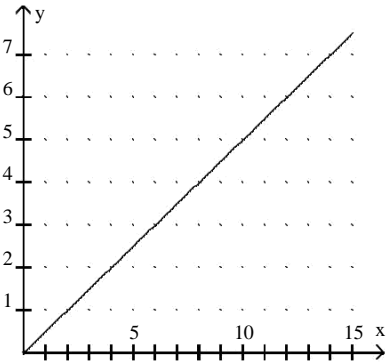

D)

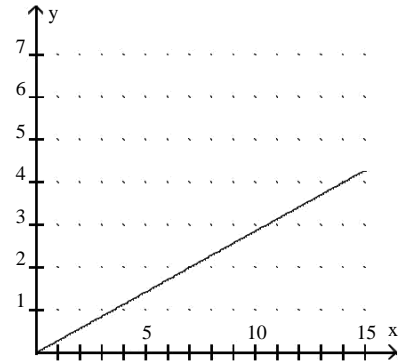

Answer: A

184) To convert x square yards to y square feet, multiply x by 9. Let $y = f(x)$ and $0 \leq x \leq 10$.

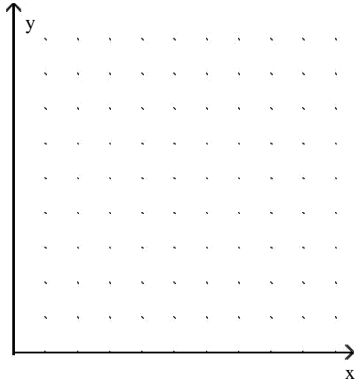

A)

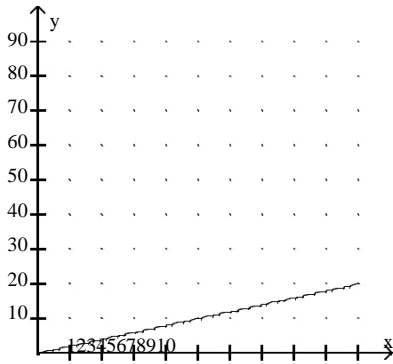

B)

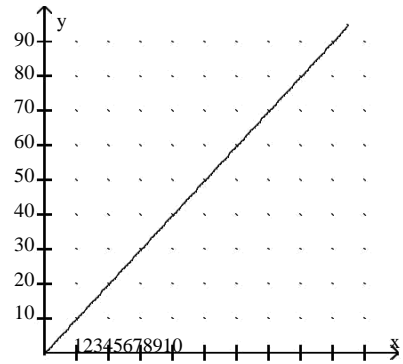

C)

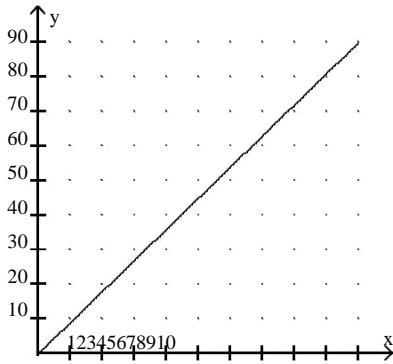

D)

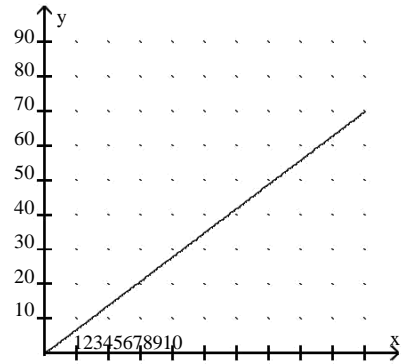

Answer: C

185) To convert x square feet to y square yards, divide x by 9. Let $y = f(x)$ and $0 \leq x \leq 100$.

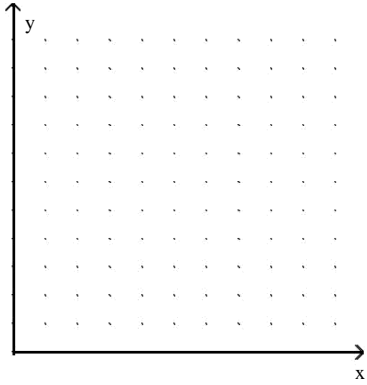

A)

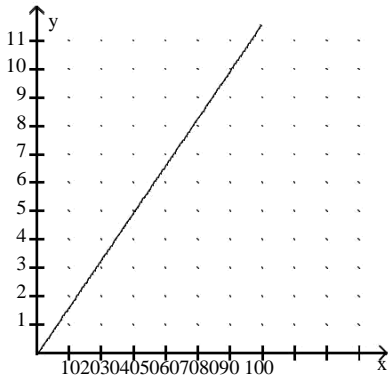

B)

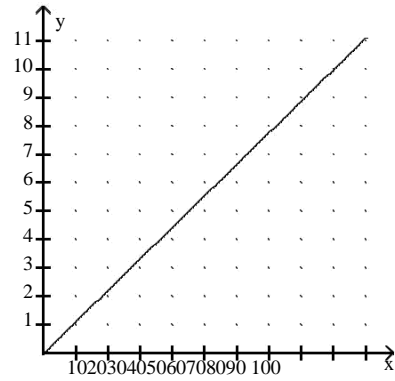

C)

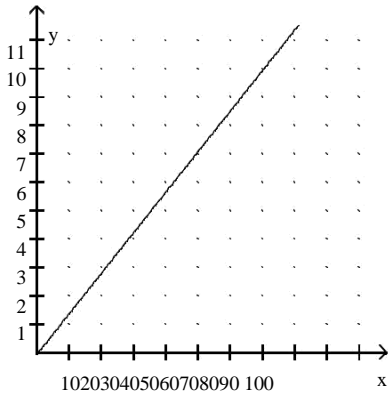

D)

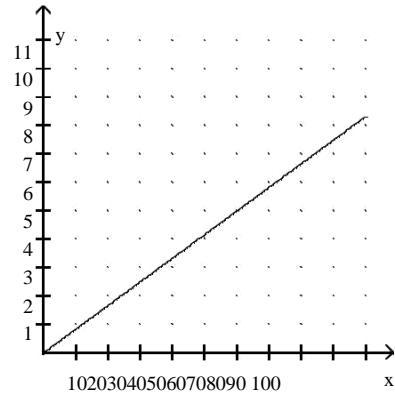

Answer: B

186) Surveyors use the "link" as a unit of measure. To convert x links to y inches, multiply x by 7.92. Let $y = f(x)$ and $0 \leq x \leq 10$.

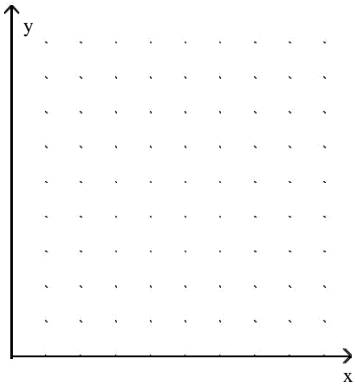

A)

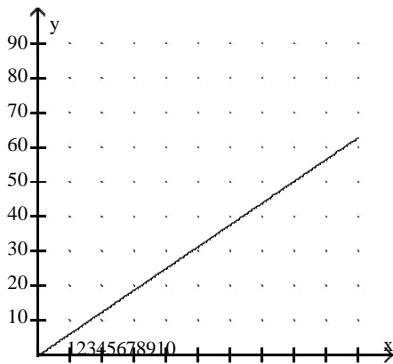

B)

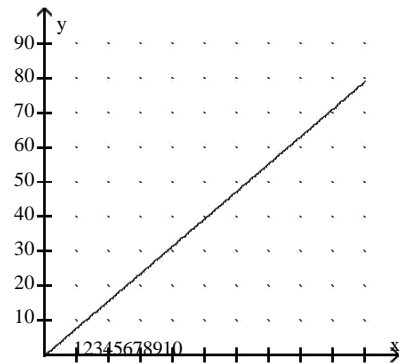

C)

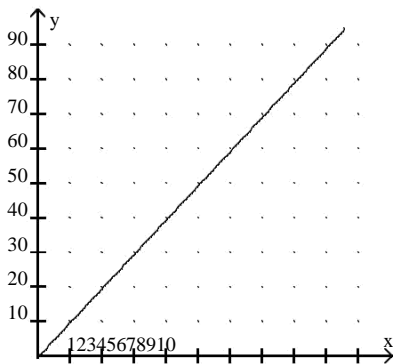

D)

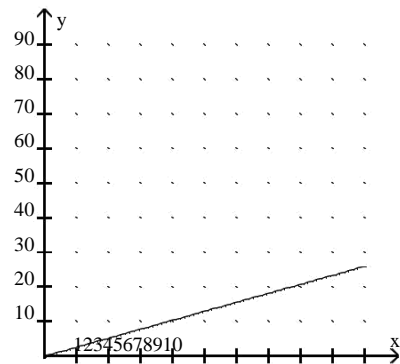

Answer: B

187) Surveyors use the "link" as a unit of measure. To convert x inches to y links, divide x by 7.92. Let $y = f(x)$ and $0 = x$

-100.

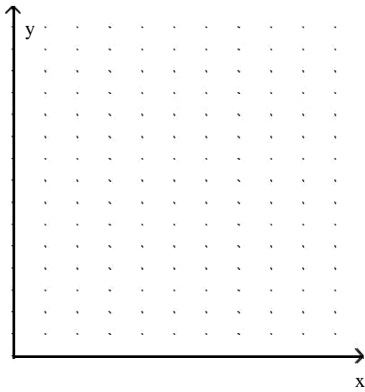

A)

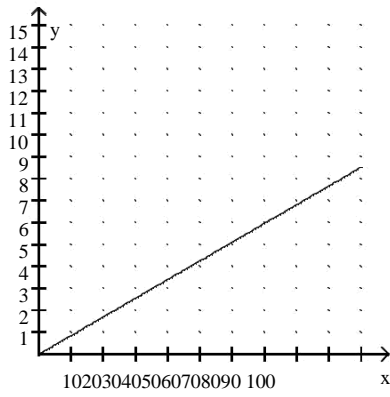

B)

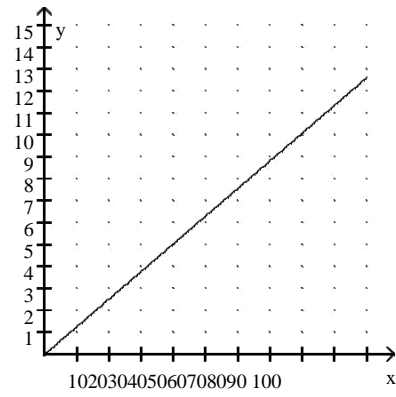

C)

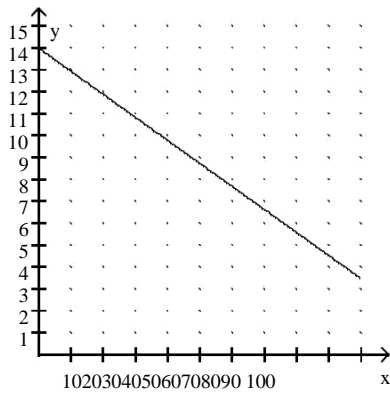

D)

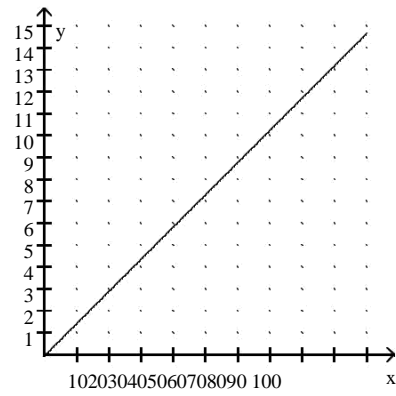

Answer: B

188) Bob buys a car that gets 9 miles per gallon of gasoline. Give a representation to compute the number of miles, y , that Bob can travel with x gallons of gasoline. Let $0 \leq x \leq 10$.

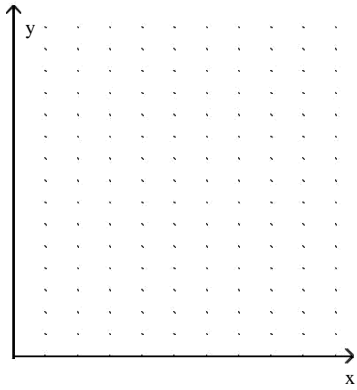

A)

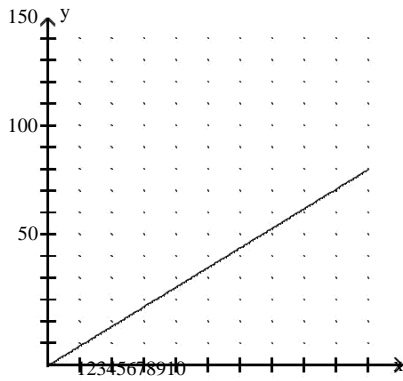

B)

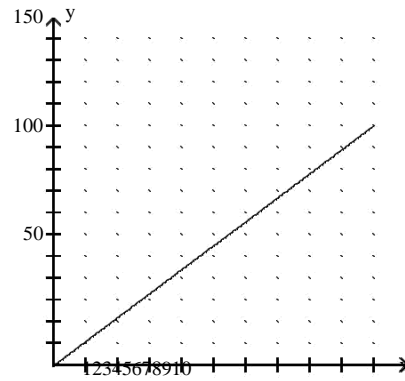

C)

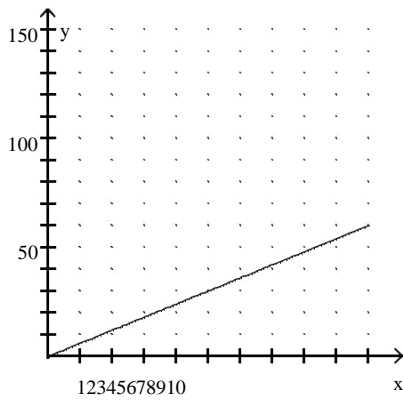

D)

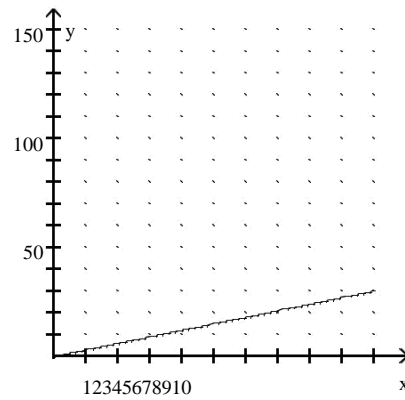

Answer: A

Give a verbal representation for the given function.

189) $f(x) = 4x^2$. Let $y = f(x)$.

- A) To obtain y : Square x , then add 4 to the result.
- B) To obtain y : Add 4 to x , then square the result.
- C) To obtain y : Square x , then multiply the result by 4.
- D) To obtain y : Multiply x by 4, then square the result.

Answer: C

190) $f(x) = 6x - 11$. Let $y = f(x)$.

- A) To obtain y : Multiply x by 6, then subtract 11 from the result. B) To obtain y : Multiply x by 11, then subtract 6 from the result. C) To obtain y : Divide x by 6, then subtract 11 from the result. D) To obtain y : Subtract 11 from x , then multiply the result by 6.

Answer: A

191) $f(x) = \frac{x}{6} + 12$. Let $y = f(x)$.

- A) To obtain y : Multiply x by 6, then add 12 to the result. B) To obtain y : Divide x by 6, then add 12 to the result. C) To obtain y : Add 12 to x , then divide the result by 6.
- D) To obtain y : Multiply x by 12, then divide the result by 6.

Answer: B

192) $f(x) = 4$. Let $y = f(x)$.

- A) y is equal to 4 plus x . B) y is equal to 4.
- C) y is equal to 4 minus x . D) y is equal to 4 times x .

Answer: B

193) $f(x) = -x + 4$. Let $y = f(x)$.

- A) To obtain y : Add 4 to x .
- B) To obtain y : If x is positive or equal to zero, add 4 to x . If x is negative, add 4 to the opposite of x . C) To obtain y : Multiply x by -1, then add 4 to the result.
- D) To obtain y : Add 4 to the opposite of x .

Answer: B

194) $f(x) = 8 - x$. Let $y = f(x)$.

- A) To obtain y : Multiply x by -1, then subtract 8 from the result.
- B) To obtain y : Subtract 8 from x .
- C) To obtain y : Multiply 8 by -1, then subtract x from the result. D) To obtain y : Subtract x from 8.

Answer: D

195) $f(x) = 14 - 4x$. Let $y = f(x)$.

- A) To obtain y : Subtract 4 from 14, then multiply the result times x .
- B) To obtain y : Multiply x by 4, then subtract the result from 14. C) To obtain y : Multiply x by 14, then subtract the result from 4. D) To obtain y : Add 4 to x , then add 14 to the result.

Answer: B

Use the table to solve the problem.

196) For a function f , we have the following numerical representation.

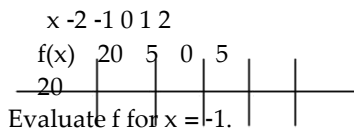

- A) 10
- B) 5
- C)
- D) 0

Answer: B

20

197) For a function f we have the following numerical representation.

x	-2	-1	0	1	2		
$f(x)$	7	6	5	6			

Evaluate f for $x = -1$.

- A) 5 B) 7 C) 0 D) 6

Answer: D

198) For a function f we have the following numerical representation.

x	-2	-1	0	1			
$y = f(x)$	8	7	6	7			

Evaluate f for $x = 2$.

- A) 0 B) 8 C) 6 D) 7

Answer: B

199) For a function f we have the following numerical representation.

x	-2	-1	0	1	2		
$y = f(x)$	-0.4	-0.2	3	0.2			

Evaluate f for $x = -1$.

- A) -0.2 B) -0.4 C) 0.2 D) 0.4

Answer: A

200) For a function f we have the following numerical representation.

x	-0.29	-0.14	3	0.14	-0.29	0	-1	1	2
$y = f(x)$									

Evaluate f for $x = 2$.

- A) -0.29 B) -0.14 C) 3 D) 0.29

Answer: D

201) The cost in dollars of driving a certain make and model of car for x miles is given by the function f . A numerical representation of f is given in the following table.

x	0	0.50	1.00	1.50	2.00	2.50	5	6
$y = f(x)$	3.00							

Use the table to evaluate f for $x = 3$.

- A) \$2.00 B) \$1.50 C) \$3.00 D) \$0.50

Answer: B

202) The cost in dollars of driving a certain make and model of car for x miles is given by the function f . A numerical representation of f is given in the following table.

x	0	1	2	3	4	5	6
$y = f(x)$	0	0.491	0.98	1.47	1.96	2.45	2.94

If the cost is \$1.96, how many miles have been driven? A) 3 miles B) 6 miles C) 5 miles D) 4 miles

Answer: D

203) The cost in dollars of driving a certain make and model of car for x miles is given by the function f . A numerical representation of f is given in the following table.

x	0	1	2	3	4	5	6
$y = f(x)$	0	0.491	0.98	1.47	1.96	2.45	2.94

If the cost is \$0.98, how many miles have been driven? A) 1 miles B) 4 miles C) 3 miles D) 2 miles

Answer: D

204) The cost, in dollars, of a cab ride for x miles is given by the function f in the following table.

x	0	1	2	3	4	5	6
$y = f(x)$	2.85	3.45	4.05	4.65	5.25	5.85	6.45

What is the cost of a 4-mile cab ride? A) \$4.05 B) \$3.45 C) \$5.25 D) \$4.65

Answer: D

205) The cost, in dollars, of a cab ride for x miles is given by the function f in the following table.

x	0	1	2	3	4	5	6
$y = f(x)$	3.04	3.83	4.62	5.41	6.20	7.00	7.79

After 1 mile has been driven, what is the cost of each additional mile? A) \$0.71 B) \$0.82 C) \$0.67 D) \$0.79

Answer: D

Determine if the relation is a function.

206)

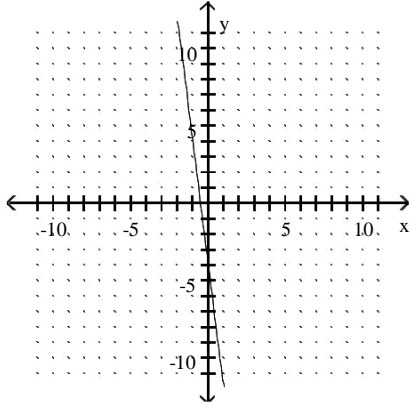

A) Function

B) Not a function

Answer: A

207)

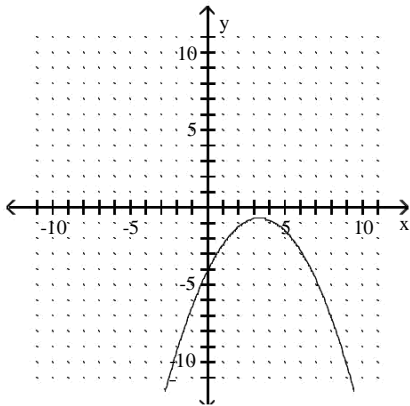

A) Not a function

B) Function

Answer: B

208)

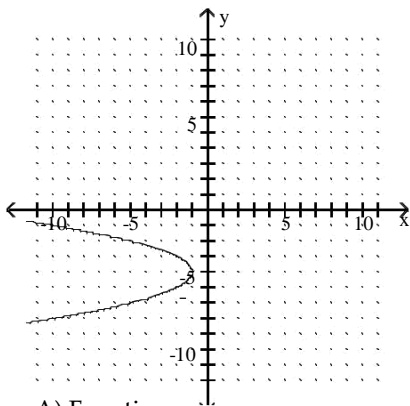

A) Function

B) Not a function

Answer: B

209)

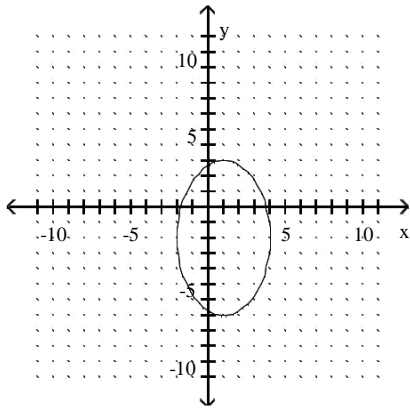

A) Function

B) Not a function

Answer: B

210)

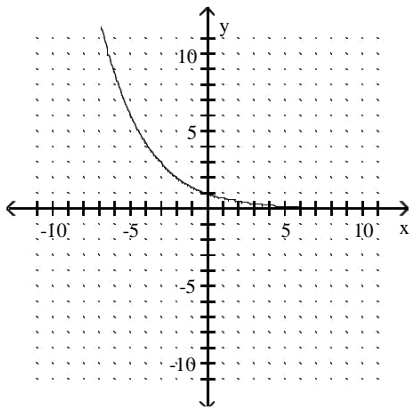

A) Not a function

B) Function

Answer: B

211)

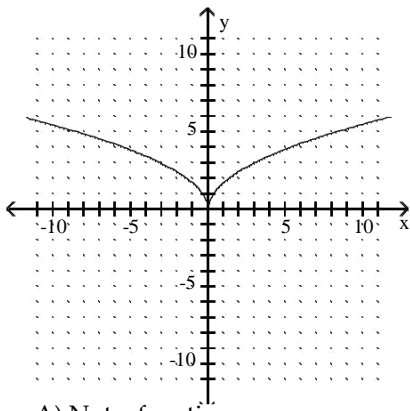

A) Not a function

B) Function

Answer: B

212) $S = \{(17, -15), (18, -13), (34, 0), (16, -15), (-17, -18)\}$ A)

Not a Function

B) Function

Answer: B

213) $S = \{(-9, -16), (-8, -14), (-18, 0), (-10, -16), (-9, -19)\}$

A) Function

B) Not a Function

Answer: B

214)
$$\begin{array}{c|cccccccc} x & -3 & -2 & -1 & & & 1 & & 3 & 4 \\ \hline y & -0.1 & 0.1 & -0.2 & 0.2 & -0.4 & 0.42 & -0.8 & 0.8 & \end{array}$$

A) Not a Function

B) Function

Answer: B

215)
$$\begin{array}{c|cccccccc} x & -3 & -2 & -1 & 0 & -1 & -2 & -3 & -4 \\ \hline y & -1.9 & 1.9 & -3.8 & 3.8 & -1.8 & 1.8 & & \end{array}$$

A) Not a Function

B) Function

Answer: A

Answer the question.

216) In a gymnasium, a group of 32 students are individually counted off by fours to determine teams; i.e. "1, 2, 3, 4, 1, 2, 3, 4, 1, 2, ..." Is a function generated by a relation that takes a student's number as input and outputs the student's name with that number?

A) No

B) Yes

Answer: A

217) In the equation $x = y^3 - 10$, is y a function of x? A) Yes

B) No

Answer: A

For the given function expressed verbally, give a symbolic representation. 218)

To convert x inches to y centimeters, multiply x by 2.54. Let $y = f(x)$.

A) $f(x) = x - 2.54$

B) $f(x) = x/2.54$

C) $f(x) = 2.54x$

D) $f(x) = 2.54/x$

Answer: C

219) To convert x centimeters to y inches, divide x by 2.54. Let $y = f(x)$. A)

$f(x) = 2.54 - x$

B) $f(x) = 2.54/x$

C) $f(x) = x/2.54$

D) $f(x) = 2.54x$

Answer: C

220) To convert x square yards to y square feet, multiply x by 9. Let $y = f(x)$. A)

$f(x) = x/9$

B) $f(x) = 9x$

C) $f(x) = 9/x$

D) $f(x) = 9 - x$

Answer: B

221) To convert x square feet to y square yards, divide x by 9. Let $y = f(x)$. A)

$f(x) = 9/x$

B) $f(x) = 9x$

C) $f(x) = x/9$

D) $f(x) = x - 9$

Answer: C

222) Surveyors use the "link" as a unit of measure. To convert x links to y inches, multiply x by 7.92. Let $y = f(x)$. A)

$f(x) = 7.92x$

B) $f(x) = x/7.92$

C) $f(x) = 7.92/x$

D) $f(x) = x + 7.92$

Answer: A

223) Surveyors use the "link" as a unit of measure. To convert x inches to y links, divide x by 7.92. Let $y = f(x)$. A)

$f(x) = 7.92x$

B) $f(x) = x/7.92$

C) $f(x) = 7.92/x$

D) $f(x) = 7.92 - x$

Answer: B

- 224) Bob buys a car that gets 9 miles per gallon of gasoline. Give a representation to compute the number of miles, y , that Bob can travel with x gallons of gasoline. Let $y = f(x)$. A) $f(x) = 9x$ B) $f(x) = x + 9$ C) $f(x) = 9/x$ D) $f(x) = x/9$
 Answer: A

Solve the problem.

- 225) Assume the function f computes the number y in millions of people using the internet in year x .
 $f = \{(1996, 1.2), (1998, 4.3), (2000, 9.8)\}$
 Evaluate $f(2000)$ and give the domain and range of f
 A) $f(2000) = 9.8$; D: $\{1996, 1998, 2000\}$, R: $\{1.2, 4.3, 9.8\}$ B) $f(2000) = 4.3$; D: $\{1.2, 4.3, 9.8\}$, R: $\{1996, 1998, 2000\}$ C) $f(2000) = 9.8$; D: $\{1.2, 4.3, 9.8\}$, R: $\{1996, 1998, 2000\}$
 D) $f(2000) = 1.2$; D: $\{1996, 1998, 2000\}$, R: $\{1.2, 4.3, 9.8\}$
 Answer: A

- 226) The stretch in a loaded spring varies with the load it supports. If the spring stretches 6.9 cm for every pound of load added, find the distance in centimeters that the spring has stretched when 8 pounds are added.
 A) 55.2 cm B) 14.9 cm C) 8 cm D) -1.1 cm
 Answer: A

Find the slope of the line that goes through the pair of points.

- 227) (4, -8) and (2, 4)
 A) 12 B) 2 C) -6 D) 6
 Answer: C

- 228) (-4, -4) and (3, 9)
 A) 1^6_7 B) Undefined C) 1^7_6 D) 5
 Answer: A

- 229) (-1, -3) and (-6, 2)
 A) -1 B) 5 C) Undefined D) -5
 Answer: A

- 230) (-3, -9) and (1, 2)
 A) Undefined B) 2^3_4 C) 1 D) -2^3_4
 Answer: B

- 231) (3, -8) and (3, 4)
 A) Undefined B) 2 C) 12 D) 6
 Answer: A

- 232) (-7, -9) and (4, -9)
 A) 0 B) 4 C) -4 D) 1
 Answer: A

State the slope of the graph of f.

233) $f(x) = 5x + 18$

A) 0

B) -18

C) 18

D) 5

Answer: D

234) $f(x) = \frac{2}{3}x + 2$

A) 2

B) $\frac{3}{2}$

C) $\frac{2}{3}$

D) 0

Answer: C

Solve the problem.

235) The amount of money, in dollars, raised each year by a band booster club can be estimated by the function $f(x) = 149x - 291,515$, where x is the year with $1990 = x = 2000$. What is the slope of the graph of f ? A) 4995 B) -149 C) -291,515 D) 149

Answer: D

236) The decline in the value of a stock can be estimated by the function $f(x) = -0.65x + 1375.5$, where x is the year with $1990 = x = 2000$. What is the slope of the graph of f ?

A) 82

B) 1375.5

C) -0.65

D) 0.65

Answer: C

State whether the given function is linear and constant, linear but not constant, or nonlinear. 237)

$f(x) = -3x + 7$

A) none of these

B) linear, constant

C) nonlinear

D) linear, but not constant

Answer: D

238) $f(x) = -9x^3 - 5x + 17$

A) linear, but not constant

B) linear, constant

C) nonlinear

D) none of these

Answer: C

239) $f(x) = -5x^{1.45} + 6$

A) linear, but not constant

B) nonlinear

C) linear, constant

D) none of these

Answer: B

240) $f(x) = -4x^4 - 2x^3 - 8x^2 + 0.12x - 10$ A)

linear, but not constant

B) none of these

C) nonlinear

D) linear, constant

Answer: C

241) $f(x) = -0.96x - 1.2$

A) nonlinear

B) linear, constant

C) linear, but not constant

D) none of these

Answer: C

242) $f(x) = 4$

- A) linear, but not constant
- C) nonlinear

- B) none of these
- D) linear, constant

Answer: D

243) $f(x) = x\sqrt{x+16}$

- A) linear, constant
- C) linear, but not constant

- B) none of these
- D) nonlinear

Answer: D

Determine if the data in the table are linear or nonlinear.

244)

x	14	15	16	17	18		
y	2	2	2	2	2		

- A) linear

- B) nonlinear

Answer: A

245)

x	2	3	4	5			
y	7	9	11	13	15		

- A) nonlinear

- B) linear

Answer: B

246)

x	1	2	3	4		
y	5	11	18			

- A) linear

- B) nonlinear

Answer: B

247)

x	3	4	5	7			
y	1	11	15	17	21		

- A) linear

- B) nonlinear

Answer: A

248)

x	-4	-2	0	2	4		
y	20	8	4	8	20		

- A) linear

- B) nonlinear

Answer: B

Identify the slope, y-intercept, and x-intercept.

249)

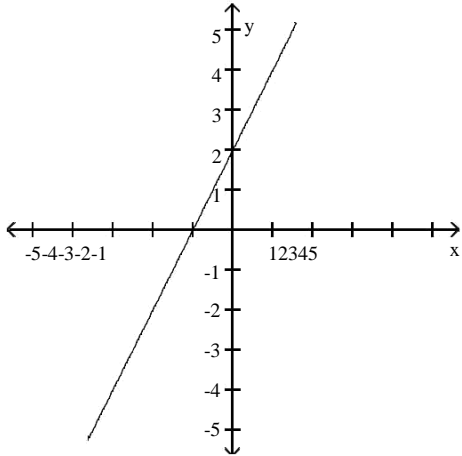

- A) Slope: 3; y-intercept: 2; x-intercept: - 1
- C) Slope: 2; y-intercept: - 1; x-intercept: 2

- B) Slope: -2; y-intercept: - 1; x-intercept: 2
- D) Slope: 2; y-intercept: 2; x-intercept: - 1

Answer: D

250)

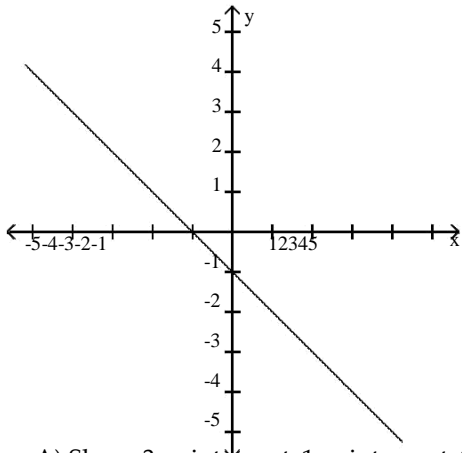

- A) Slope: 3; y-intercept: 1; x-intercept: 1
- C) Slope: -1; y-intercept: -1; x-intercept: - 1

- B) Slope: 1; y-intercept: -1; x-intercept: - 1
- D) Slope: -3; y-intercept: 1; x-intercept: 1

Answer: C

Write the equation of the line whose graph is shown.

251)

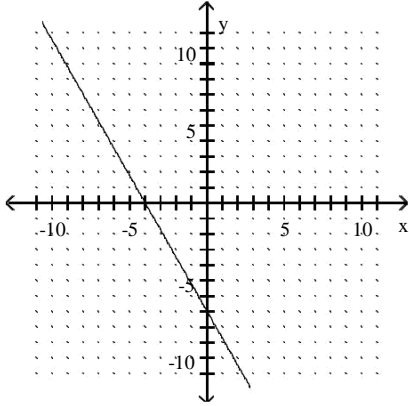

A) $y = -\frac{7}{4}x - 7$

B) $y = 4x - 7$

C) $y = -4x - 7$

D) $y = -\frac{4}{7}x - 4$

Answer: A

252)

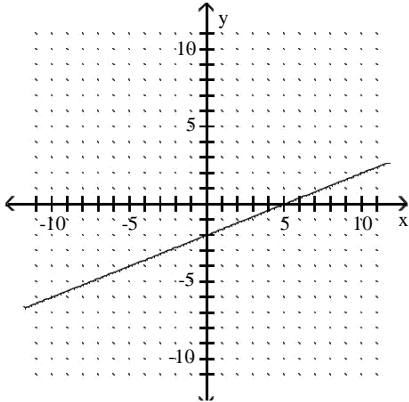

A) $y = \frac{5}{2}x + 5$

B) $y = -5x - 2$

C) $y = 5x - 2$

D) $y = \frac{2}{5}x - 2$

Answer: D

253)

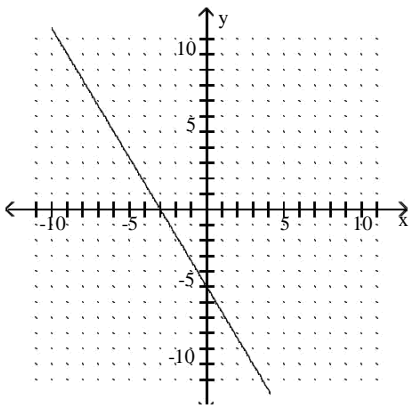

A) $y = 3x - 5$

B) $y = -\frac{3}{5}x - 3$

C) $y = -3x - 5$

D) $y = -\frac{5}{3}x - 5$

Answer: D

254)

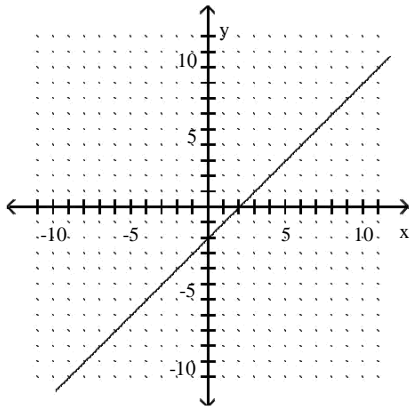

A) $y = -x + 2$

B) $y = x - 2$

C) $y = -x - 2$

D) $y = x + 2$

Answer: B

255)

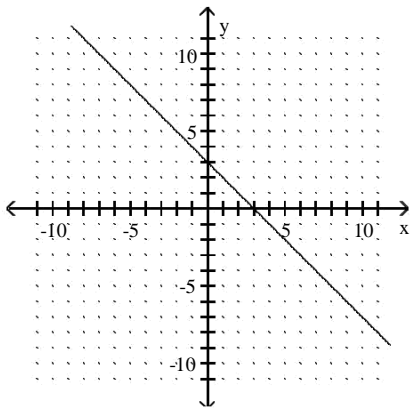

A) $y = x + 3$

B) $y = x - 3$

C) $y = -x + 3$

D) $y = -x - 3$

Answer: C

Use the given graph to find the x-intercept and the zero of the function. 256)

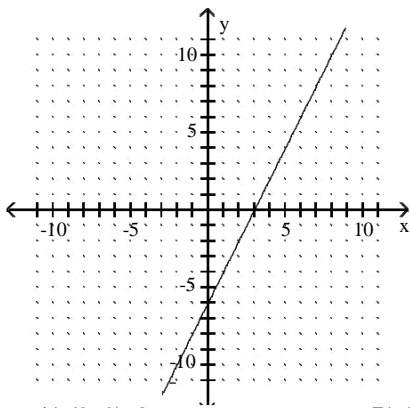

A) (3, 0); 3

B) (3, -6); 3

C) (-6, 0); -6

D) (0, 0); 0

Answer: A

257)

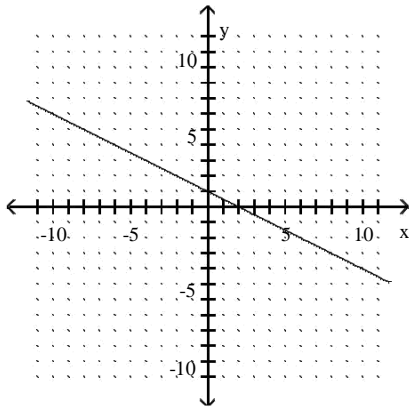

A) $(2, 0); 2$

B) $(0, 0); 0$

C) $(2, 1); 2$

D) $(1, 0); 1$

Answer: A

258)

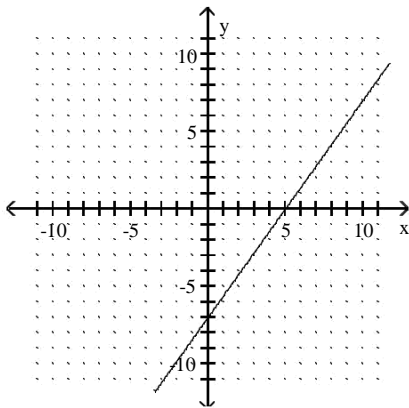

A) $(5, 0); 5$

B) $(5, -7); 5$

C) $(-7, 0); -7$

D) $(0, 0); 0$

Answer: A

Write a formula for a linear function f whose graph satisfies the conditions.

259) Slope: $-\frac{6}{7}$; y-intercept: $\frac{33}{7}$

A) $f(x) = -\frac{6}{7}x - \frac{33}{7}$

B) $f(x) = \frac{6}{7}x - \frac{33}{7}$

C) $f(x) = -\frac{6}{7}x + \frac{33}{7}$

D) $f(x) = \frac{6}{7}x + \frac{33}{7}$

Answer: C

260) Slope: $-\frac{5}{4}$; y-intercept: 8

A) $f(x) = -\frac{5}{4}x + 8$

B) $f(x) = \frac{5}{4}x + 8$

C) $f(x) = -\frac{5}{4}x - 8$

D) $f(x) = \frac{5}{4}x - 8$

Answer: A

261) Slope: $\frac{3}{2}$; y-intercept: -2

A) $f(x) = -\frac{3}{2}x - 2$

B) $f(x) = \frac{3}{2}x - 2$

C) $f(x) = \frac{3}{2}x + 2$

D) $f(x) = -\frac{3}{2}x + 2$

Answer: B

262) Slope: $\frac{1}{4}$; y-intercept: 3

A) $f(x) = \frac{1}{4}x - 3$

B) $f(x) = \frac{1}{4}x + 3$

C) $f(x) = -\frac{1}{4}x - 3$

D) $f(x) = -\frac{1}{4}x + 3$

Answer: B

263) Slope: $\frac{7}{2}$; y-intercept: -11

A) $f(x) = -\frac{7}{2}x + 11$

B) $f(x) = -\frac{7}{2}x - 11$

C) $f(x) = \frac{7}{2}x - 11$

D) $f(x) = \frac{7}{2}x + 11$

Answer: C

264) Slope: 2; passing through the origin

A) $f(x) = \frac{1}{2}x$

B) $f(x) = 2x$

C) $f(x) = -2x$

D) $f(x) = 2$

Answer: B

265) Slope: 1.2; passing through (1, 3.5)

A) $f(x) = 1.2x + 2.3$

B) $f(x) = 1.2x + 1.9$

C) $f(x) = 1.2x + 3.5$

D) $f(x) = -1.2x + 2.6$

Answer: A

Express the following in interval notation.

266) $x = 5$

A) $(-8, 5]$

B) $[5, 8)$

C) $(5, 8)$

D) $(-8, 5)$

Answer: B

267) $x < -50$

A) $[-50, 8)$

B) $(-8, -50)$

C) $(-50, 8)$

D) $(-8, -50]$

Answer: B

268) $-6 < x < -5$

A) $(-8, -6] \cup [-5, 8)$

B) $(-6, -5)$

C) $[-6, -5]$

D) $(-8, -6) \cup (-5, 8)$

Answer: B

269) $2 = x < 10$

A) $[2, 10)$

B) $(2, 10]$

C) $(2, 10)$

D) $[2, 10]$

Answer: A

270) $10 = x > -4$

A) $(-8, -4] \cup (10, 8)$

B) $(-8, -4) \cup [10, 8)$

C) $(-4, 10]$

D) $[-4, 10)$

Answer: C

271) $\{x \mid x = -6\}$

A) $[-6, 8)$

B) $(-6, 8)$

C) $(-8, -6)$

D) $(-8, -6]$

Answer: D

272) $\{x \mid x > 9\}$

A) $(-8, 9)$

B) $[9, 8)$

C) $(-8, 9]$

D) $(9, 8)$

Answer: D

273) $\{x \mid 10 < x\}$
 A) $[10, 8)$ B) $(10, 8)$ C) $(-8, 10]$ D) $(-8, 10)$
 Answer: B

274) $\{x \mid x < -5 \text{ or } x > 1\}$
 A) $(-5, 1)$ B) $[-5, 1]$ C) $(-8, -5) \cup (1, 8)$ D) $(-8, -5] \cup [1, 8)$
 Answer: C

275) $\{x \mid x < -5 \text{ or } x = -1\}$
 A) $(-8, -5) \cup (-1, 8)$ B) $[-5, -1)$ C) $(-5, -1]$ D) $(-8, -5] \cup (-1, 8)$
 Answer: A

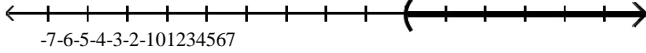
276)

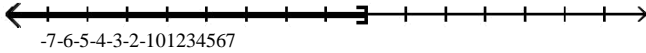
 A) $[2, 8)$ B) $(-8, 2)$ C) $(-8, 2]$ D) $(2, 8)$
 Answer: D

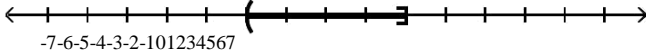
277)

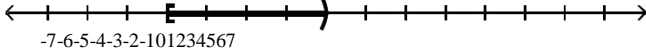
 A) $(-8, 1)$ B) $[1, 8)$ C) $(-8, 1]$ D) $(1, 8)$
 Answer: C

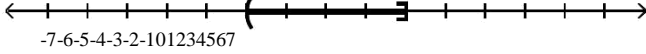
278)

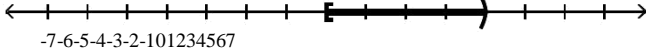
 A) $[-2, 2]$ B) $[-2, 2)$ C) $(-2, 2]$ D) $(-2, 2)$
 Answer: C

279)

 A) $(0, 4]$ B) $(-4, 0]$ C) $[0, 4)$ D) $[-4, 0)$
 Answer: D

280)

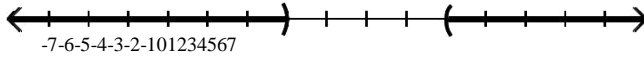
 A) $[-2, 2]$ B) $[-2, 2)$ C) $(-2, 2]$ D) $(-2, 2)$
 Answer: C

281)

 A) $(0, 4]$ B) $(-4, 0]$ C) $[-4, 0)$ D) $[0, 4)$
 Answer: D

282)



A) $(-8, -1) \cup (3, 8)$

B) $[-1, 3]$

C) $(-1, 3)$

D) $(-8, -1] \cup [3, 8)$

Answer: A

283)

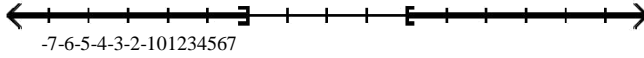

A) $(-8, -2) \cup (2, 8)$

B) $(-2, 2)$

C) $[-2, 2]$

D) $(-8, -2] \cup [2, 8)$

Answer: D

284)

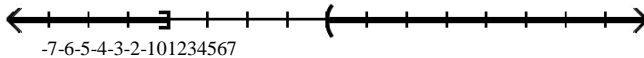

A) $(-8, -4) \cup (0, 8)$

B) $(-8, -4) \cup [0, 8)$

C) $[-4, 0)$

D) $(-8, -4] \cup (0, 8)$

Answer: D

285)

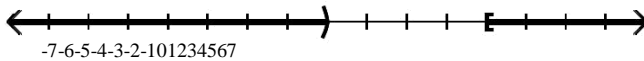

A) $(-8, 0) \cup [4, 8)$

B) $(-8, 0) \cup (4, 8)$

C) $(-8, 0] \cup (4, 8)$

D) $(0, 4]$

Answer: A

Use the graph of f to determine the intervals where f is increasing and where f is decreasing. 286)

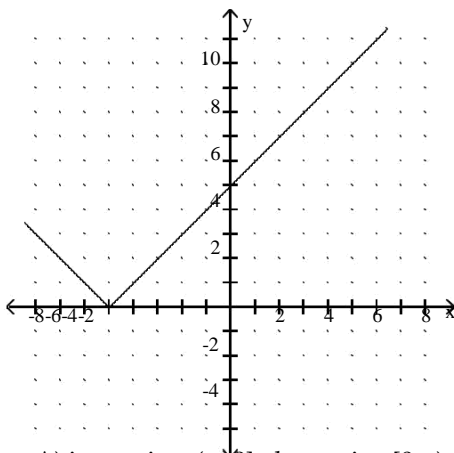

A) increasing: $(-8, 0]$; decreasing $[0, 8)$

C) increasing: $(-8, 8)$; decreasing: never

B) increasing: $(-8, -5]$; decreasing $[-5, 8)$

D) increasing: $[-5, 8)$; decreasing $(-8, -5]$

Answer: D

287)

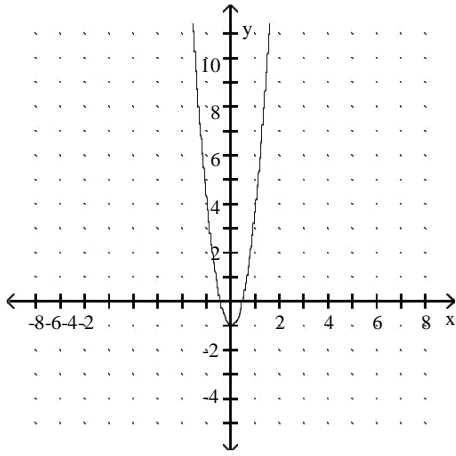

- A) increasing: never; decreasing: $(-8, 8)$
- C) increasing: $(-8, 0]$; decreasing $[0, 8)$

- B) increasing: $(-8, 8)$; decreasing: never
- D) increasing: $[0, 8)$; decreasing $(-8, 0]$

Answer: D

288)

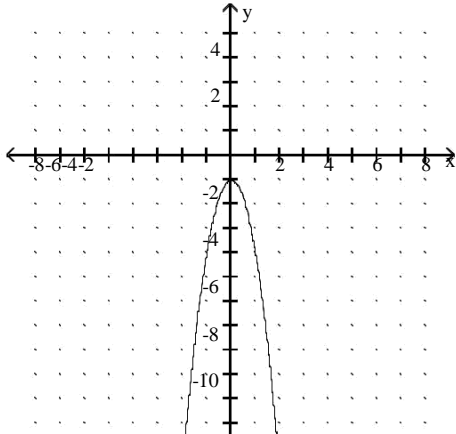

- A) increasing: $[0, 8)$; decreasing $(-8, 0]$
- C) increasing: never; decreasing: $(-8, 8)$

- B) increasing: $(-8, 8)$; decreasing: never
- D) increasing: $(-8, 0]$; decreasing $[0, 8)$

Answer: D

289)

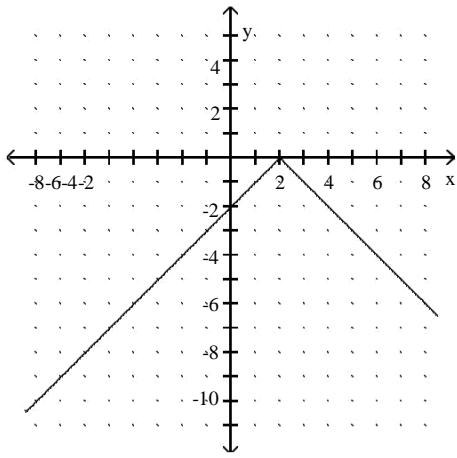

- A) increasing: $(-8, 0]$; decreasing $[0, 8)$
- C) increasing: $(-8, 2]$; decreasing $[2, 8)$

Answer: C

- B) increasing: $(-8, 8)$; decreasing: never
- D) increasing: $[2, 8)$; decreasing $(-8, 2]$

290)

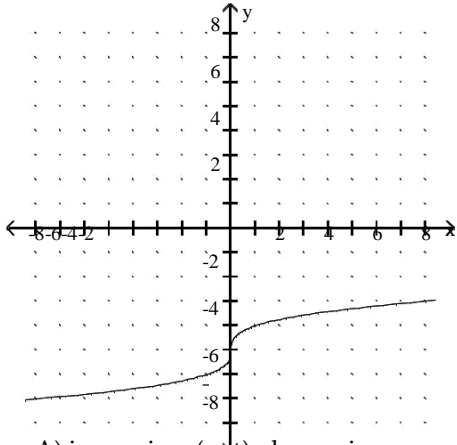

- A) increasing: $(-8, 8)$; decreasing: never
- C) increasing: never; decreasing: $(-8, 8)$

Answer: A

- B) increasing: $(-8, 0]$; decreasing $[0, 8)$
- D) increasing: $[0, 8)$; decreasing $(-8, 0]$

291)

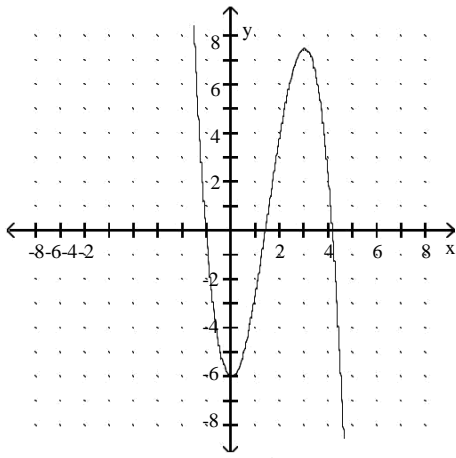

- A) increasing: $[2, 8]$; decreasing: $(-8, 2]$
 C) increasing: $[0, 8]$; decreasing: $(-8, 0]$

- B) increasing: $[0, 3]$; decreasing: $(-8, 0] \cup [3, 8)$
 D) increasing: $(-8, 1] \cup [2, 8)$; decreasing: $[1, 2]$

Answer: B

292)

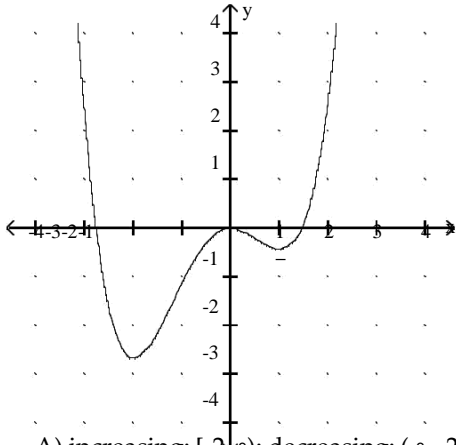

- A) increasing: $[-2, 8]$; decreasing: $(-8, -2]$ B) increasing: $[0, 8]$; decreasing: $(-8, 0]$
 C) increasing: $[-2, 0] \cup [1, 8]$; decreasing: $(-8, -2] \cup [0, 1]$ D) increasing: $[-2, 1]$; decreasing: $(-8, -2] \cup [1, 8)$

Answer: C

Identify where f is increasing and where f is decreasing.

293) $f(x) = 2$

- A) increasing: $[2, 8]$; decreasing: never
 C) neither

- B) increasing: $(-8, 8)$; decreasing: never
 D) increasing: never; decreasing: $[2, 8)$

Answer: C

294) $f(x) = 5x - 4$

- A) increasing: never; decreasing: $(-8, 8)$
 C) neither

- B) increasing: $[-4, 8]$; decreasing: $(-8, -4]$
 D) increasing: $(-8, 8)$; decreasing: never

Answer: D

295) $f(x) = -3x + 2$

- A) neither
C) increasing: $(-8, 8)$; decreasing: never

Answer: D

- B) increasing: $[2, 8)$; decreasing: $(-8, 2]$
D) increasing: never; decreasing: $(-8, 8)$

296) $f(x) = x^2 + 3$

- A) increasing: $(-8, 8)$; decreasing: never
C) increasing: $(-8, 0]$; decreasing $[0, 8)$

Answer: D

- B) increasing: $[3, 8)$; decreasing: never
D) increasing: $[0, 8)$; decreasing $(-8, 0]$

297) $f(x) = 6x - x^2$

- A) increasing: $(-8, 3]$; decreasing $[3, 8)$
C) increasing: $(-8, 6]$; decreasing $[6, 8)$

Answer: A

- B) increasing: $[6, 8)$; decreasing $(-8, 6]$
D) increasing: $[3, 8)$; decreasing $(-8, 3]$

298) $f(x) = x^2 + 2x$

- A) increasing: $(-8, 2]$; decreasing $[2, 8)$
C) increasing: $(-8, -1]$; decreasing $[-1, 8)$

Answer: B

- B) increasing: $[-1, 8)$; decreasing $(-8, -1]$
D) increasing: $[2, 8)$; decreasing $(-8, 2]$

299) $f(x) = x\sqrt{8}$

- A) increasing: $[8, 8)$; decreasing: never
C) increasing: never; decreasing: $[-8, 8)$

Answer: A

- B) increasing: $[-8, 8)$; decreasing: never
D) increasing: never; decreasing: $[8, 8)$

300) $f(x) = -x\sqrt{8}$

- A) increasing: never; decreasing: $[8, 8)$
C) increasing: never; decreasing: $[-8, 8)$

Answer: C

- B) increasing: $[-8, 8)$; decreasing: never
D) increasing: $[8, 8)$; decreasing: never

301) $f(x) = x - 7$

- A) increasing: $(-8, -7]$; decreasing: $[-7, 8)$
C) increasing: $[-7, 8)$; decreasing: $(-8, -7]$

Answer: D

- B) increasing: $(-8, 7]$; decreasing: $[7, 8)$
D) increasing: $[7, 8)$; decreasing: $(-8, 7]$

302) $f(x) = x + 4$

- A) increasing: $(-8, -4]$; decreasing: $[-4, 8)$
C) increasing: $[-4, 8)$; decreasing: $(-8, -4]$

Answer: C

- B) increasing: $(-8, 4]$; decreasing: $[4, 8)$
D) increasing: $[4, 8)$; decreasing: $(-8, 4]$

Identify where f is increasing or where f is decreasing, as indicated. Round your answer to two decimal places when appropriate.

303) $f(x) = -6x^2 + 24x$; increasing

- A) $[2, 8)$ B) $(-8, -2]$

C) $[-2, 8)$

D) $(-8, 2]$

Answer: D

304) $f(x) = -3x^2 + 6x - 1$; decreasing

- A) $(-8, 1]$ B) $(-8, -1]$

C) $[-1, 8)$

D) $[1, 8)$

Answer: D

305) $f(x) = |5x - 4|$ increasing

A) $(-8, 0.80]$

B) $[-0.80, 0.80]$

C) $[0.80, 8)$

D) $(-8, 8)$

Answer: C

306) $f(x) = x^3 - 4x - 7$; decreasing

A) $[-2.00, 2.00]$

C) $(-8, -1.15]$

B) $(-8, -1.15] \cup [1.15, 8)$

D) $[-1.15, 1.15]$

Answer: D

307) $f(x) = x^4 - 10x^2 + 16$; decreasing

A) $(-8, -2.83) \cup (-1.41, 1.41) \cup (2.83, 8)$

C) $(-2.24, 0) \cup (2.24, 8)$

B) $(-2.83, -1.41) \cup (1.41, 2.83)$

D) $(-8, -2.24) \cup (0, 2.24)$

Answer: D

Use the graph and formula for $f(x)$ to find the average rates of change of f from -4 to -1 and from 1 to 4 . 308)

$f(x) = 3$

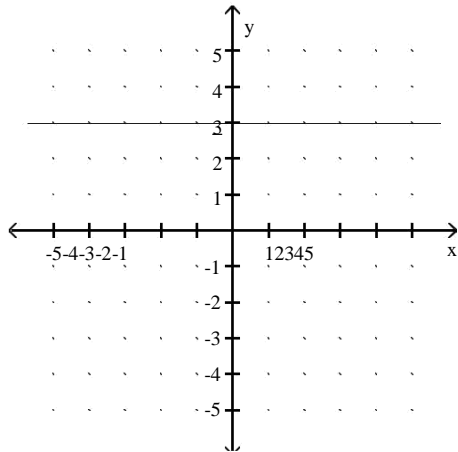

A) $3; -3$

B) $3; 3$

C) $0; 0$

D) $-3; -3$

Answer: C

309) $f(x) = 2x - 4$

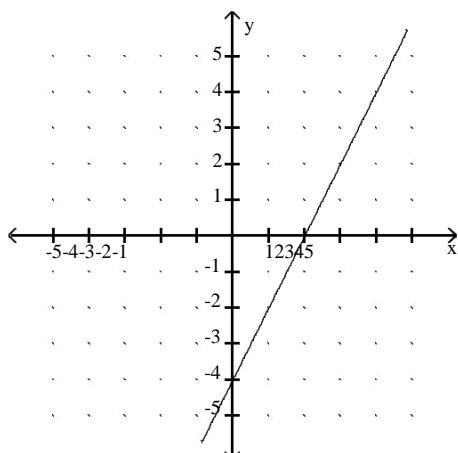

A) $-2; 2$

B) $-2; -2$

C) $4; 4$

D) $2; 2$

Answer: D

310) $f(x) = -4x + 1$

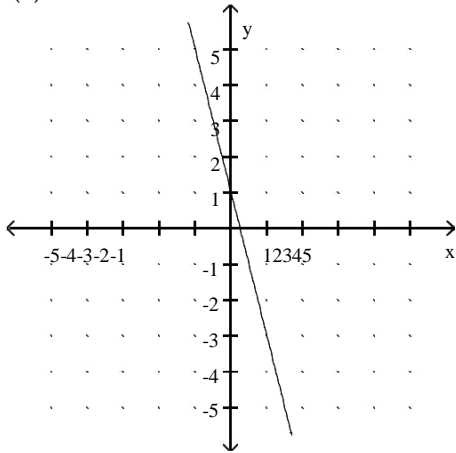

A) -4; -4

B) 4; -4

C) 4; 4

D) -4; 4

Answer: A

311) $f(x) = 0.4x^2 - 3$

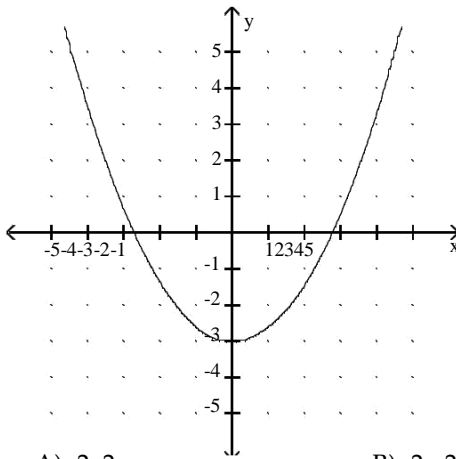

A) -2; 2

B) -2; -2

C) 2; 2

D) 2; -2

Answer: A

312) $y = -0.4x^2 + 3$

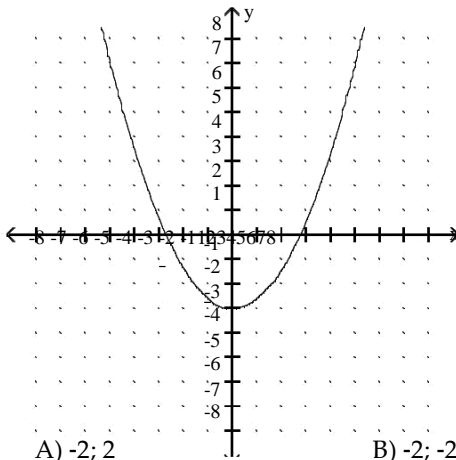

A) -2; 2

B) -2; -2

C) 2; -2

D) 2; 2

Answer: C

Compute the average rate of change of f from x_1 to x_2 . Round your answer to two decimal places when appropriate. Interpret your result graphically.

313) $f(x) = 6x + 4$, $x_1 = -4$ and $x_2 = -1$

A) 7; the slope of the line passing through $(-4, f(-4))$ and $(-1, f(-1))$ is 7. B) 5; the slope of the line passing through $(-4, f(-4))$ and $(-1, f(-1))$ is 5. C) 6; the slope of the line passing through $(-4, f(-4))$ and $(-1, f(-1))$ is 6. D) 8; the slope of the line passing through $(-4, f(-4))$ and $(-1, f(-1))$ is 8.

Answer: C

314) $f(x) = -3x + 3$, $x_1 = -6$ and $x_2 = -3$

A) -4; the slope of the line passing through $(-6, f(-6))$ and $(-3, f(-3))$ is -4. B) 3; the slope of the line passing through $(-6, f(-6))$ and $(-3, f(-3))$ is 3. C) -3; the slope of the line passing through $(-6, f(-6))$ and $(-3, f(-3))$ is -3. D) 2; the slope of the line passing through $(-6, f(-6))$ and $(-3, f(-3))$ is 2.

Answer: C

315) $f(x) = x^3 - 4x$, $x_1 = 2$ and $x_2 = 4$

A) 8; the slope of the line passing through $(2, f(2))$ and $(4, f(4))$ is 8. B) 24; the slope of the line passing through $(2, f(2))$ and $(4, f(4))$ is 24. C) -8; the slope of the line passing through $(2, f(2))$ and $(4, f(4))$ is -8. D) -24; the slope of the line passing through $(2, f(2))$ and $(4, f(4))$ is -24.

Answer: B

316) $f(x) = 3x - \sqrt{x}$, $x_1 = 1$ and $x_2 = 3$

A) 0.58; the slope of the line passing through $(1, f(1))$ and $(3, f(3))$ is 0.58. B) -0.58; the slope of the line passing through $(1, f(1))$ and $(3, f(3))$ is -0.58. C) -0.71; the slope of the line passing through $(1, f(1))$ and $(3, f(3))$ is -0.71. D) 0.71; the slope of the line passing through $(1, f(1))$ and $(3, f(3))$ is 0.71.

Answer: D

Complete the following for the given $f(x)$. (i)

Find $f(x + h)$.

(ii) Find the difference quotient of f and simplify.

317) $f(x) = -4$

A) (i) $h - 4$
(ii) h

B) (i) -4
(ii) -4

C) (i) $h - 4$
(ii) 0

D) (i) -4
(ii) 0

Answer: D

318) $f(x) = -9x$

A) (i) $-9x - 9h$
(ii) 9

B) (i) $-9x + 9h$
(ii) -9

C) (i) $-9x + 9h$
(ii) 9

D) (i) $-9x - 9h$
(ii) -9

Answer: D

319) $f(x) = 2x - 11$

A) (i) $2x + 2h - 11$
(ii) 2

B) (i) $2x + 2h - 11$
(ii) -2

C) (i) $2x + 2h - 11$
(ii) 11

D) (i) $2x + h - 11$
(ii) 2

Answer: A

320) $f(x) = x^2 + 2x$

A) (i) $x^2 + 2xh + h^2 + 2x + 2h$ (ii)
 $2xh + h + 2x$

B) (i) $x^2 + h^2 + 2x + 2h$ (ii)
 $h + 2$

C) (i) $x^2 + 2xh + h^2 + 2x + 2h$ (ii)
 $2x + h + 2$

D) (i) $x^2 + 2xh + h^2 + 2x + h$ (ii)
 $2x + h + 1$

Answer: C

321) $f(x) = 6x^2 + 9x - 9$

A) (i) $6x^2 + 12xh + 6h^2 + 9x + 9h - 9$
(ii) $12xh + 9h + 6h^2$

B) (i) $6x^2 + 12xh + 6h^2 + 9x - 9$ (ii)
 $12x + 9$

C) (i) $6x^2 + 12xh + 6h^2 + 9x + 9h - 9$ (ii)
 $12x + 6h + 9$

D) (i) $6x^2 + 6xh + 6h^2 + 9x + 9h - 9$ (ii)
 $6x + 6 + 12h$

Answer: C

Solve the problem.

322) The profit (in millions of dollars) for Allied Manufacturing can be approximated by $f(x) = 0.342x - 509.2$, where x is the year $1989 = x = 2009$. Approximate the average rate of change over a 7-year period. Round your answer to three decimal places when appropriate.

- A) 2.394 million dollars
C) 4.404 million dollars

- B) 1.894 million dollars
D) 3.964 million dollars

Answer: A

323) The profit (in millions of dollars) for Allied Manufacturing can be approximated by $f(x) = -0.225x + 910.2$, where x is the year $1989 = x = 2009$. Approximate the average rate of change over a 3-year period. Round your answer to three decimal places when appropriate.

- A) -6.285 million dollars
C) -0.675 million dollars

- B) 0.135 million dollars
D) -0.885 million dollars

Answer: C

324) The following table gives the outside temperature in degrees Fahrenheit on a winter day in Death Valley, California.

Time	7:00 am	8:00 am	9:00 am	10:00 am	11:00 am
Temperature (°F)	78	82	85	91	95

Calculate the average rate of change in temperature between 8:00 am and 11:00 am. Round your answer to two decimal places when appropriate.

A) 4.64°F

B) 4.33°F

C) 3.26°F

D) 5.36°F

Answer: B

325) The distance D in feet that an object has fallen after t seconds is given by $D(t) = 16t^2$.

(i) Evaluate $D(2)$ and $D(5)$.

(ii) Calculate the average rate of change of D from 2 to 5. Interpret the result.

A) (i) 32, 80

(ii) 112; the object's average speed from 2 to 5 seconds is 112 ft/sec.

B) (i) 64, 400

(ii) 112; the object's average speed from 2 to 5 seconds is 112 ft/sec.

C) (i) 64, 400

(ii) 48; the object's average speed from 2 to 5 seconds is 48 ft/sec.

D) (i) 32, 80

(ii) 48; the object's average speed from 2 to 5 seconds is 48 ft/sec.

Answer: B

326) Let the number of gallons G of water drained from a pool after t hours be given by $G(t) = 4375 - 175t$ for $0 \leq t \leq 25$.

(i) Find $G(t + h)$.

(ii) Find the difference quotient. Interpret your result.

A) (i) $4375 - 175t + 175h$

(ii) -175 ; the pool is being emptied at a constant rate of 175 gal/hr. B)

(i) $4375 - 175t - 175h$

(ii) -175 ; the pool is being emptied at a constant rate of 175 gal/hr. C)

(i) $4375 - 175t + h$

(ii) 1; the pool is being emptied at a constant rate of 1 gal/hr. D)

(i) $4375 - 175t + 175h$

(ii) 175; the pool is being emptied at a constant rate of 175 gal/hr.

Answer: B